

# FURUNO

## OPERATOR'S MANUAL

SATELLITE COMPASS

---

MODEL SC-60

---



**FURUNO ELECTRIC CO., LTD.**  
NISHINOMIYA, JAPAN

© **FURUNO ELECTRIC CO., LTD.**

9-52 Ashihara-cho,  
Nishinomiya, Japan

Telephone : 0798-65-2111  
fax : 0798-65-4200

Your Local Agent/Dealer

All rights reserved.

Printed in Japan

PUB.No. OME-72480

( KAMI ) SC-60

FIRST EDITION : FEB. 2001

U1 : FEB. 26,2004



\* 0 0 0 8 0 9 1 9 1 0 6 \*



\* O M E 7 2 4 8 0 U 1 0 \*



# SAFETY INSTRUCTIONS

## Safety Instructions for the Operator

### **WARNING**

**Do not open the equipment.**

Only qualified personnel should work inside the equipment.

**Do not disassemble or modify the equipment.**

Fire, electrical shock or serious injury can result.

**Immediately turn off the power at the switchboard if the equipment is emitting smoke or fire.**

Continued use of the equipment can cause fire or electrical shock. Contact a FURUNO agent for service.

**Do not place liquid-filled containers on the top of the processor unit.**

Fire or electrical shock may result if the liquid enters the equipment.

### **CAUTION**

**No one navigation device should ever be solely relied upon for the navigation of a vessel.**

Always confirm position against all available aids to navigation, for safety of vessel and crew.

**Use the proper fuse.**

Use of a wrong fuse can result in damage to the equipment.

## Safety Instructions for the Installer

### **WARNING**

**Do not open the cover unless totally familiar with electrical circuits and service manual.**

Improper handling can result in electrical shock.

**Turn off the power at the switchboard before beginning the installation.**

Fire or electrical shock can result if the power is left on.

**Do not install the equipment where it may get wet from rain or water splash.**

Water in the equipment can cause fire, electrical shock or damage to the equipment.

### **NOTICE**

**Observe the following compass safe distances to prevent interference to a magnetic compass:**

|                               | Standard<br>Compass | Steering<br>Compass |
|-------------------------------|---------------------|---------------------|
| Display unit<br>SC-602        | 0.5 m               | 0.3 m               |
| Processor unit<br>SC-601/601D | 1.3 m               | 0.8 m               |
| Antenna unit<br>SC-303        | 0.3 m               | 0.3 m               |
| Antenna unit<br>SC-603        | 0.3 m               | 0.3 m               |
| DGPS beacon<br>antenna GR-8   | 0.3 m               | 0.3 m               |

# TABLE OF CONTENTS

---

|   |            |
|---|------------|
| FOREWORD.....   | iv         |
| SYSTEM CONFIGURATION .....  | v          |
| EQUIPMENT LIST .....  | vi         |
| SOFTWARE VERSION LIST .....                                       | vii        |
| SPECIFICATIONS .....  | SP-1       |
| <br>  |            |
| <b>1 PRINCIPLE OF OPERATION.....</b>                              | <b>1-1</b> |
| <br>  |            |
| <b>2 INSTALLATION .....</b>                                       | <b>2-1</b> |
| 2.1 Mounting Considerations .....                                 | 2-1        |
| 2.1.1 SC-series antenna unit.....                                 | 2-1        |
| 2.1.2 Display unit, processor unit.....                           | 2-3        |
| 2.2 Installing the Antenna Units .....                            | 2-4        |
| 2.2.1 SC-series antenna unit.....                                 | 2-4        |
| 2.2.2 DGPS antenna unit .....                                     | 2-7        |
| 2.3 Installing the Processor Unit.....                            | 2-9        |
| 2.3.1 Deck mount .....  | 2-9        |
| 2.3.2 Bulkhead mount .....  | 2-10       |
| 2.3.3 Installation on the underside of a desk .....               | 2-12       |
| 2.3.4 Adjusting for orientation error.....                        | 2-14       |
| 2.4 Installing the Display Unit.....                              | 2-14       |
| 2.4.1 Desktop, overhead mounting .....                            | 2-14       |
| 2.4.2 Flush mount.....  | 2-15       |
| 2.5 Wiring.....   | 2-16       |
| 2.6 Initial Settings.....   | 2-19       |
| 2.6.1 Confirming satellite status; choosing mounting method ..... | 2-19       |
| 2.6.2 Choosing heading source .....                               | 2-20       |
| 2.6.3 Heading data format.....                                    | 2-21       |
| 2.7 Connection of External Equipment .....                        | 2-22       |
| 2.8 Installing the DGPS Beacon Receiver Kit.....                  | 2-22       |
| <br>  |            |
| <b>3 OPERATION.....</b>   | <b>3-1</b> |
| 3.1 Controls.....   | 3-1        |
| 3.2 Turning the Power On/Off .....                                | 3-2        |
| 3.3 Panel Illumination, Display Contrast.....                     | 3-2        |
| 3.4 Choosing a Display .....                                      | 3-3        |
| 3.4.1 Description of displays .....                               | 3-3        |
| 3.5 Alarms .....  | 3-5        |
| 3.6 Confirming Satellite Status.....                              | 3-6        |
| 3.7 GPS Setup .....   | 3-7        |
| 3.7.1 Displaying the GPS setup menu .....                         | 3-7        |
| 3.7.2 GPS SETUP menu description .....                            | 3-7        |

|          |  |                |
|----------|--|----------------|
| 3.8      | Output Data.....   | 3-8            |
| 3.8.1    | Heading.....   | 3-8            |
| 3.8.2    | Navigation data.....                                       | 3-9            |
| 3.8.3    | Interface.....   | 3-9            |
| 3.8.4    | Log pulse.....   | 3-10           |
| 3.8.5    | Talker identifier mnemonics.....                           | 3-10           |
| 3.9      | System Setup.....  | 3-11           |
| 3.9.1    | Geodetic data.....   | 3-11           |
| 3.9.2    | Units of measurement.....                                  | 3-12           |
| 3.9.3    | Using local time.....                                      | 3-12           |
| 3.9.4    | Time format.....   | 3-12           |
| 3.9.5    | Demonstration mode.....                                    | 3-13           |
| 3.10     | DGPS Setup.....  | 3-13           |
| 3.10.1   | Manual DGPS setup.....                                     | 3-13           |
| 3.10.2   | Programming user beacon stations.....                      | 3-15           |
| 3.10.3   | Editing user beacon stations.....                          | 3-16           |
| 3.10.4   | Erasing individual user stations.....                      | 3-17           |
| 3.10.5   | Erasing all user beacon stations.....                      | 3-17           |
| 3.11     | OTHERS Menu.....   | 3-18           |
| 3.12     | TRIP Menu.....   | 3-19           |
| 3.13     | Resetting Distance Run.....                                | 3-19           |
| <b>4</b> | <b>MAINTENANCE, TROUBLESHOOTING.....</b>                   | <b>4-1</b>     |
| 4.1      | Preventive Maintenance.....                                | 4-1            |
| 4.2      | Troubleshooting.....                                       | 4-2            |
| 4.3      | Diagnostics.....   | 4-2            |
| 4.4      | Program Number.....  | 4-5            |
| 4.5      | Clearing Data.....   | 4-5            |
| 4.6      | Replacement of Battery.....                                | 4-6            |
| 4.7      | Replacement of Fuse.....                                   | 4-7            |
| 4.8      | Error Messages.....  | 4-7            |
|          | <b>APPENDIX A.....</b>                                     | <b>A-1</b>     |
|          | Menu Tree.....   | A-1            |
|          | Geodetic Chart Codes.....                                  | A-2            |
|          | Digital Interface.....                                     | A-3            |
|          | Input/Output Ports.....                                    | A-10           |
|          | Parts Location.....  | A-11           |
|          | Parts List.....  | A-12           |
|          | <b>APPENDIX B Installation of Antenna Unit SC-603.....</b> | <b>B-1</b>     |
|          | <b>PACKING LISTS.....</b>                                  | <b>A-1</b>     |
|          | <b>OUTLINE DRAWINGS.....</b>                               | <b>D-1</b>     |
|          | <b>INTERCONNECTION DIAGRAMS.....</b>                       | <b>S-1</b>     |
|          | <b>INDEX.....</b>  | <b>Index-1</b> |
|          | <b>Declaration of Conformity</b>                           |                |

# FOREWORD

---

## A Word to the Owner of the SC-60

FURUNO Electric Company thanks you for purchasing the FURUNO SC-60 Satellite Compass. We are confident you will discover why the FURUNO name has become synonymous with quality and reliability.

For over 50 years FURUNO Electric Company has enjoyed an enviable reputation for quality and reliability throughout the world. This dedication to excellence is furthered by our extensive global network of agents and dealers.

Your satellite compass is designed and constructed to meet the rigorous demands of the marine environment. However, no machine can perform its intended function unless properly installed and maintained. Please carefully read and follow the operation, installation and maintenance procedures set forth in this manual.

We would appreciate feedback from you, the end-user, about whether we are achieving our purposes.

Thank you for considering and purchasing FURUNO.

## Features

The SC-60 is a new satellite compass designed with FURUNO's advanced GPS kinematic technology. This compass finds a wide range of applications for any type of ships and mobile units at sea or on land.

The main features are

- Perfect for use as heading sensor for Radar/ARPA, AIS, ECDIS, scanning sonar, and video plotter
- There are no mechanical parts such as gimbals or rotating motor, thus the compass is free from routine maintenance
- The performance is not affected by geomagnetism thus it is suitable for use on any vessel
- No need for speed correction like a gyrocompass
- Short settling time - three minutes
- Provides all necessary functions as a GPS navigator.

# SYSTEM CONFIGURATION

The SC-60 consists of an antenna, a display unit and a processor unit. The antenna is available in a low-profile radome type antenna accommodating three antenna/receiver unit, or discrete type. The tri-antenna system helps reduce the influence of ship's motion (rolling).

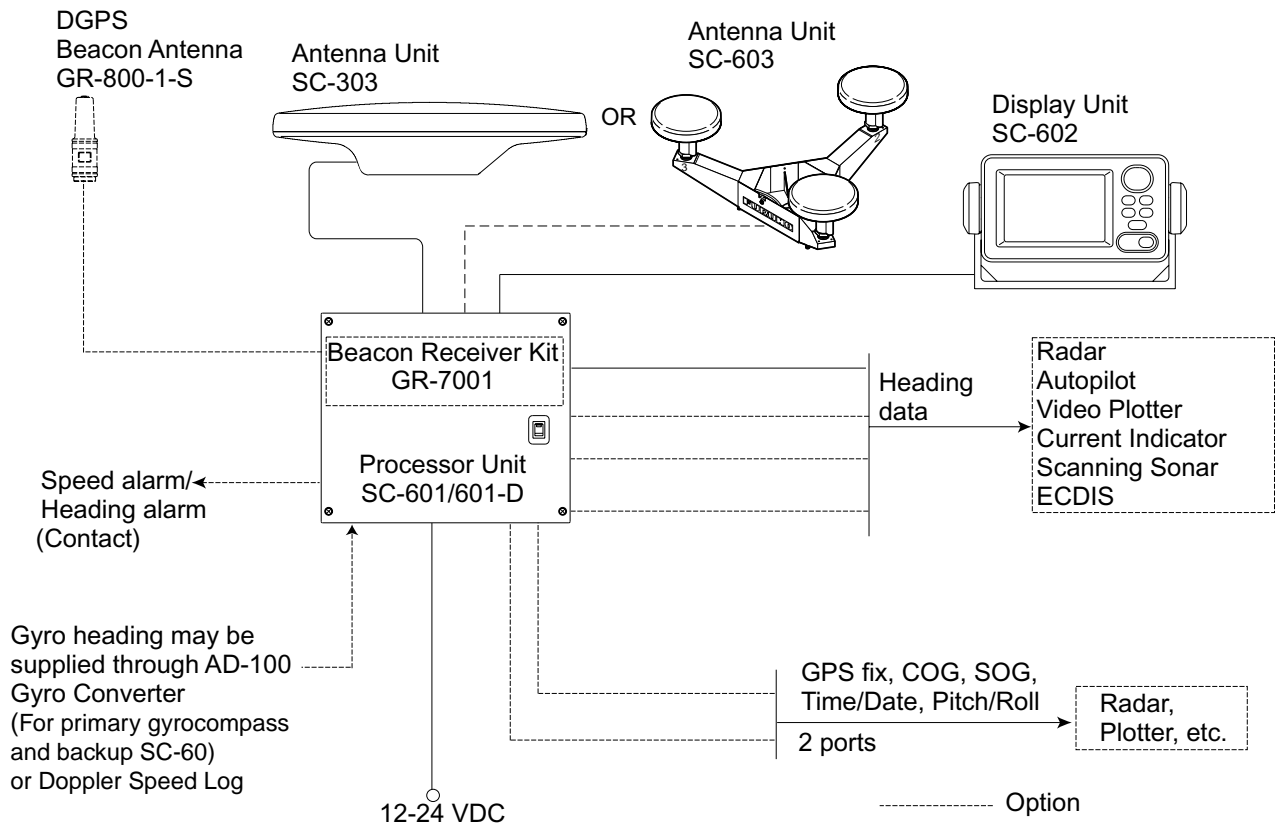

System configuration

# EQUIPMENT LIST

## Standard supply

| Name                   | Type       | Code No.    | Qty | Remarks   |
|------------------------|------------|-------------|-----|---|
| Antenna Unit           | SC-303     | —           | 1   | Radome type   |
|                        | SC-603     | —           | 1   | Open type   |
| DGPS Antenna           | GR-800-1-S | —           | 1   | No whip antenna, for SC-601-D   |
| Display Unit           | SC-602-E   | —           | 1   |   |
| Processor Unit         | SC-601     | —           | 1   | With DGPS beacon receiver   |
|                        | SC-601-D   | —           |     |   |
| Installation Materials | CP08-01602 | 004-377-880 | 1   | <u>DGPS antenna</u><br>Parker clamp, spring washer  |
|                        | CP20-02200 | 000-041-748 | 1   | <u>GPS antenna</u><br>CP20-02201, CP20-02202,<br>TPX6-3D2V-15M                                  |
|                        | CP20-02203 | —           | 1   | <u>Display Unit</u><br>Tapping screw ( 5X20, 4 pcs.)  |
|                        | CP20-02200 | 000-041-748 | 1   | <u>Processor Unit</u><br>MJ-A3SPF0013-035<br>MJ-A6SPF0007-100<br>MJ-A7SPF0006-100<br>CP20-02221 |
| Accessories            | FP14-02801 | —           | 1   | Cover   |
| Spare Parts            | SP20-00901 | 004-377-600 | 1   | Accessories for Processor Unit  |

## Optional equipment

| Name                     | Type             | Code No.       | Qty | Remarks   |
|--------------------------|------------------|----------------|-----|---|
| Cable Assy.              | MJ-A6SPF0003-050 | 000-117-603    | 1   | For AD-10 output,<br>connector at one end, 5 m                      |
|                          | MJ-A6SPF0007-100 | 000-125-237    | 1   | For AD-10 output,<br>connector at both ends, 10<br>m                |
|                          | MJ-A6SPF0012-100 | 000-133-817    | 1   | Cross for NMEA output, 10<br>m                                      |
|                          | MJ-A7SPF0003-050 | 000-136-730-01 | 1   | For beacon/log/alarm<br>signal output, connector at<br>one end, 5 m |
| Antenna Cable Set        | CP20-01700       | 004-372-110    | 1   | 30 m  |
|                          | CP20-01710       | 004-372-120    |     | 50 m  |
| DGPS Beacon Receiver Kit | GR-7001-K        | 000-041-738    | 1   | 3 pcs., for<br>SC-303   |
| Whip Antenna             | FAW-1.2          | 000-130-046    | 1   | 1.2 m   |
| Whip Antenna             | 04S4176          | 000-112-845    | 1   | 2.6 m   |
| Flush Mount F            | OP20-29          | 000-041-405    | 1   | For display unit  |
| Flush Mount S            | OP20-17          | 000-040-720    | 1   | For display unit  |
| Extension Cable          | OP08-15-30       | 004-396-440    | 1   | For DGPS, 30 m  |
|                          | OP08-15-60       | 004-396-450    |     | For DGPS, 60 m  |
| Antenna Cable Set        | OP08-17          | 004-392-510    | 1   | For DGPS  |



# SOFTWARE VERSION LIST

---

DISPLAY UNIT: 205-1312-009  
PROCESSOR UNIT: 205-1311-016  
GPS1: 205-1313-004  
GPS2: 205-1313-004  
GPS3: 205-1313-004  
DGPS: 085-0182-002

This page is intentionally left blank.

# SPECIFICATIONS OF SATELLITE COMPASS

## SC-60

### 1 GENERAL

|     |                        |                                      |
|-----|------------------------|--------------------------------------|
| 1.1 | Receiver Type          | 12 discrete channels                 |
| 1.2 | Rx Frequency           | 1575.42 MHz                          |
| 1.3 | Rx Code                | C/A code                             |
| 1.4 | Position Fixing System | All-in-view, 8-state Kalman filter   |
| 1.5 | Position Accuracy      | 10 m, or 5 m (DGPS), 95% of the time |
| 1.6 | Heading Accuracy       | ±1.0° (95%)                          |
| 1.7 | Follow-up              | 25°/s rate-of-turn                   |
| 1.8 | Settling Time          | 3 minutes                            |

### 2 DISPLAY UNIT

|     |                |   |
|-----|----------------|---|
| 2.1 | Display Type   | 4.5 inch monochrome LCD, 120 x 64 dots                                  |
| 2.2 | Effective Area | 60 mm (H) x 95 mm (W)   |
| 2.3 | Contrast       | 64 steps  |
| 2.4 | Display Mode   | Heading, Nav data, Steering, Compass rose, Rate of turn and Speed modes |

### 3 INTERFACE

|     |                      |  |
|-----|----------------------|--|
| 3.1 | Heading Data Output  | 3 ports: AD-10 or IEC 61162-1<br>1 port: NMEA 0183 (Ver1.5/2.0)<br>IEC 61162 Sentences: HDT, HDM, VTG, ZDA, GGA, ROT   |
| 3.2 | COG, SOG, L/L Output | 1 port: IEC 61162-1<br>1 port: RS-232C level<br>IEC 61162 Sentences: VTG, GGA, ZDA, GLL, ROT<br>ATT (Proprietary): incl. pitch, roll and yaw data<br>\$PFEC,GPatt,xxx.x,xx.x,xx.x<CR><LF> (Ver. 1.5)<br>\$PFEC,GPatt,xxx.x,xx.x,xx.x*hh<CR><LF> (Ver. 2.0) |
| 3.3 | Log Output           | 1 port: 200/400 pulse/nm (closure signal)  |
| 3.4 | Alarm Output         | 1 port: Alarm signal (closure signal)  |
| 3.5 | Heading Data Input   | 1 port: Backup Heading (AD-10/ IEC 61162 format) from external heading device<br>Sentences: HDT, HDG, HDM<br>(VBW, VHW, VLM for tide direction and speed)  |
| 3.6 | Beacon Data Input    | 1 port; RTCM SC-104 format for RS-232C<br>Sentences: MSK, GGA  |

#### 4 POWER SUPPLY

12-24 VDC: 1.1-0.5 A

#### 5 ENVIRONMENTAL CONDITION AND EMC

##### 5.1 Ambient Temperature

Display/Processor Unit -15°C to +55°C, Designed for protected area

Antenna Unit -25°C to +70°C, Designed for exposed area

##### 5.2 Damp Heat 93%±3% at 40°C

##### 5.3 Waterproofing

Antenna Unit IPX6

Display Unit IPX5

Processor Unit IPX0

##### 5.4 Vibration IEC 60945

##### 5.5 EMC IEC 60945

#### 6 COATING COLOR

6.1 Display/Processor Unit Panel: N3.0 Newtone No.5 (dark gray)  
Cover: 2.5GY5/1.5 (light gray)

6.2 Antenna Unit N9.5 (white)

# 1 PRINCIPLE OF OPERATION

Own ship's heading can be determined by decoding the data in the carrier frequency in addition to ordinary GPS parameters. In principle, a pair of two antennas A1(ref) and A2(fore), each connected with an associated GPS engine and processor, are installed along the ship's fore-and-aft line. GPS systems at A1 and A2 calculate the range and azimuth to the satellite. Difference in range between A1 and A2 is  $\Delta\lambda + n\lambda$  where  $\lambda$  is 19 cm. "n" is automatically found during the initialization stage by receiving three satellites. A fraction of a carrier wavelength,  $\Delta\lambda$ , is processed by FURUNO's advanced kinematic technology in geographical survey, thus determining a vector (range and orientation) A1 to A2.

In reality, a third antenna is used to reduce the influence of pitch, roll and yaw, and five satellites are processed to process 3D data. If the GPS signal is blocked by a tall building or the vessel is under a bridge, the 3-axis solid-state angular rate gyros in the processor unit take place of the satellite compass, maintaining the current heading continuously.

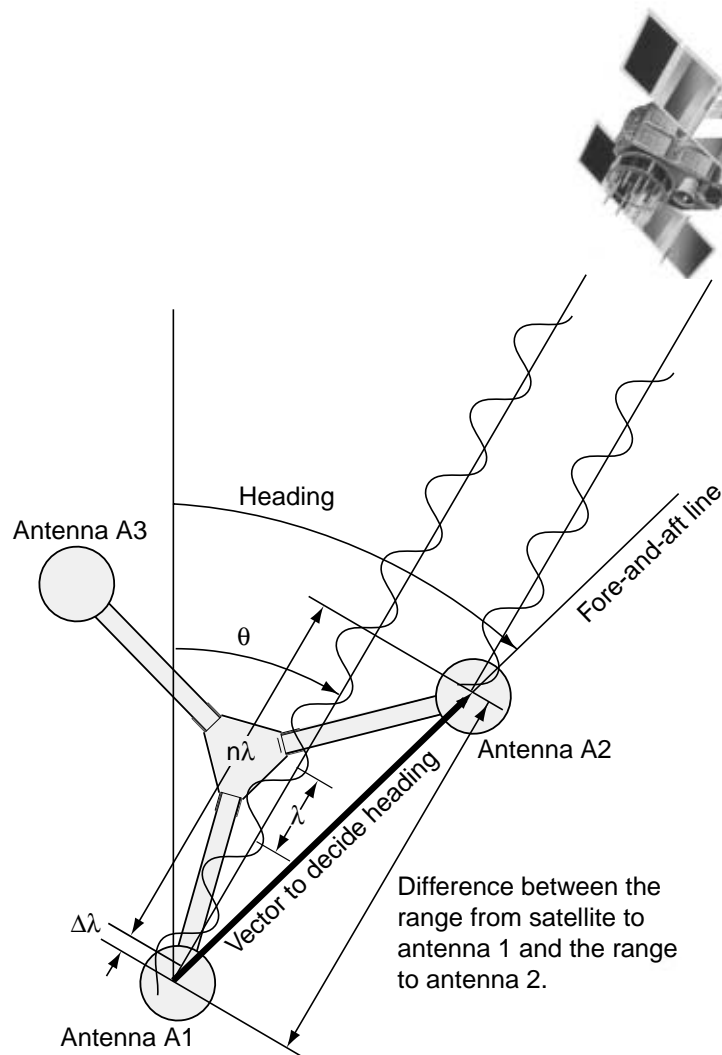

*Principle of satellite compass operation*

This page is intentionally left blank.

# 2 INSTALLATION

## 2.1 Mounting Considerations

### 2.1.1 SC-series antenna unit

#### General

- Keep the length of antenna cable in mind when selecting a mounting location. The cable comes in lengths of 15 meters (standard supply), or 30 m or 50 m (optional lengths).

#### Installing the antenna above superstructures

- The antenna must be mounted above all other structures on the vessel to obtain an unobstructed view of the satellites regardless of vessel heading. Failure to do so will cause shadows and multipath reflection problems.

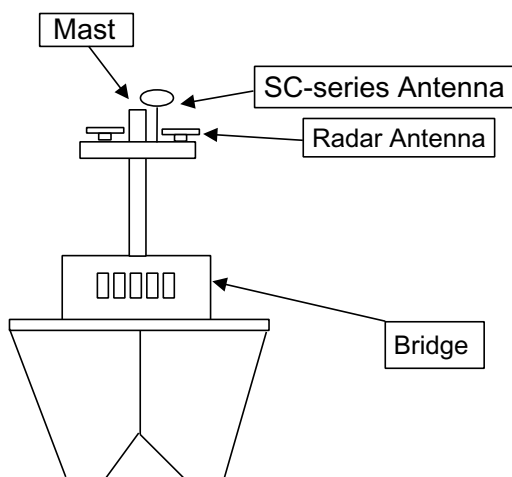

*Example of antenna installed above all superstructures*

#### Installing the antenna below superstructures

If it is not possible to mount the antenna above all superstructures on the vessel, as shown in the illustration above, shading and multipath problems may occur on at least one heading, and possibly more. To possibly avoid those problems, observe the guidelines in this section.

### **NOTICE**

**If the antenna is installed below any superstructure, the installation must be done over a two-day period, following the procedure in the service manual.**

At least 12 hours are required to capture tracking data to measure multipath indexes and locate areas of shading.

## 2. INSTALLATION

- The horizontal separation between the antenna and masts must be as follows:

| Mast diameter | Separation distance (minimum) |
|---------------|-------------------------------|
| 10 cm         | 1.5 m                         |
| 30 cm         | 3 m                           |

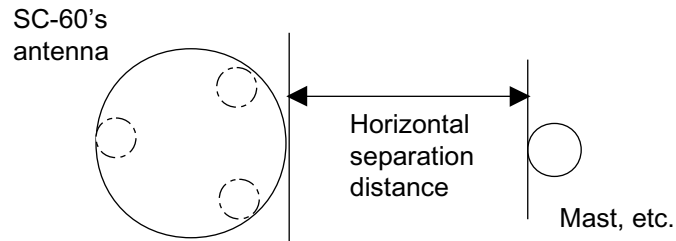

*Horizontal separation between antenna and masts*

- The field of view above the antenna should be as shown below,  $\pm 80^\circ$  against zenith. To avoid reflections from masts and the like, locate the antenna well away from the shadows of the radar mast, etc.

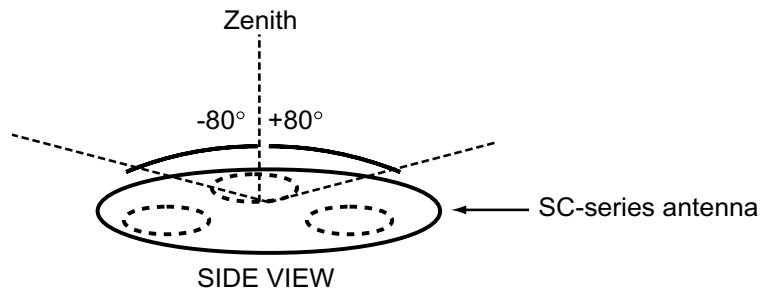

*Antenna and field of view*

- Referring to the illustration below, locate the antenna away from objects which might block reception, such as a mast.

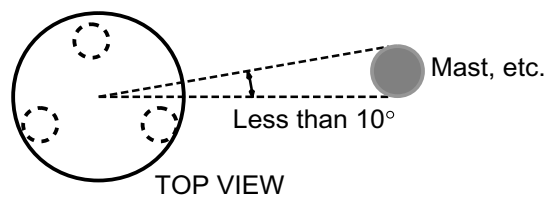

- Locate the antenna unit above the radar antenna, out of the radar beam.

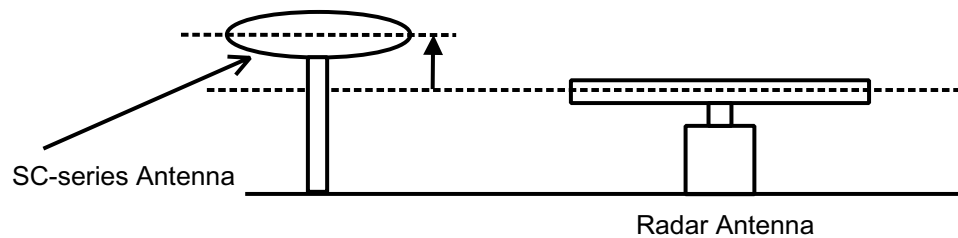



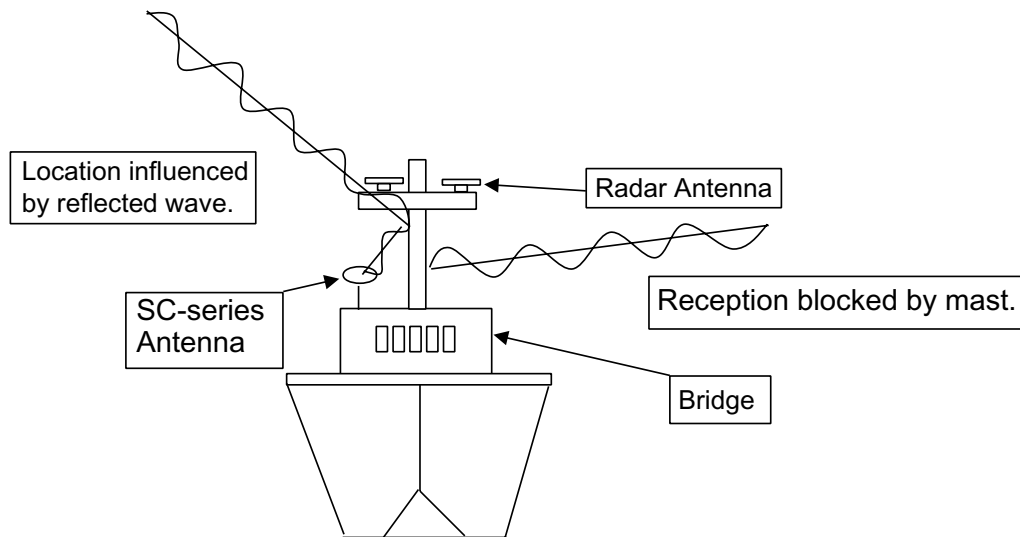

*Example of antenna installed below superstructures*

## 2.1.2 Display unit, processor unit

- Choose a location where vibration and shock are minimal.
- Install the units well away from locations subject to rain and water splash.
- Locate the units away from air conditioner vents.
- Keep the units out of direct sunlight because of heat that can build up inside their cabinets.
- Choose a well-ventilated location.
- For the display unit, choose a location where it can be easily operated.
- Leave sufficient space around the units to permit access for maintenance. See the outline drawing for recommended maintenance space.

## 2.2 Installing the Antenna Units

### 2.2.1 SC-series antenna unit

#### NOTICE

Fasten the antenna to the mounting location lastly if it is more convenient to connect the antenna cable before mounting the antenna unit.

1. Prepare a mounting platform (wood, steel or aluminum) in accordance with the illustration shown below. If corrosive material is used, take necessary anti-corrosion measures.

**Note:** When drilling holes in the platform, be sure they are parallel with the fore-and-aft line.

2. Fasten the antenna unit to the platform with four sets of M10 hex. bolts, spring washers and flat washers, orienting it as shown below. (The bow mark ( $\Delta$ ) on the antenna should face the bow.) The torque for the hex. bolts should be between 19.6-24.5 Nm.

#### NOTICE

Do not open the antenna.

This installation does not require removal of the antenna cover.

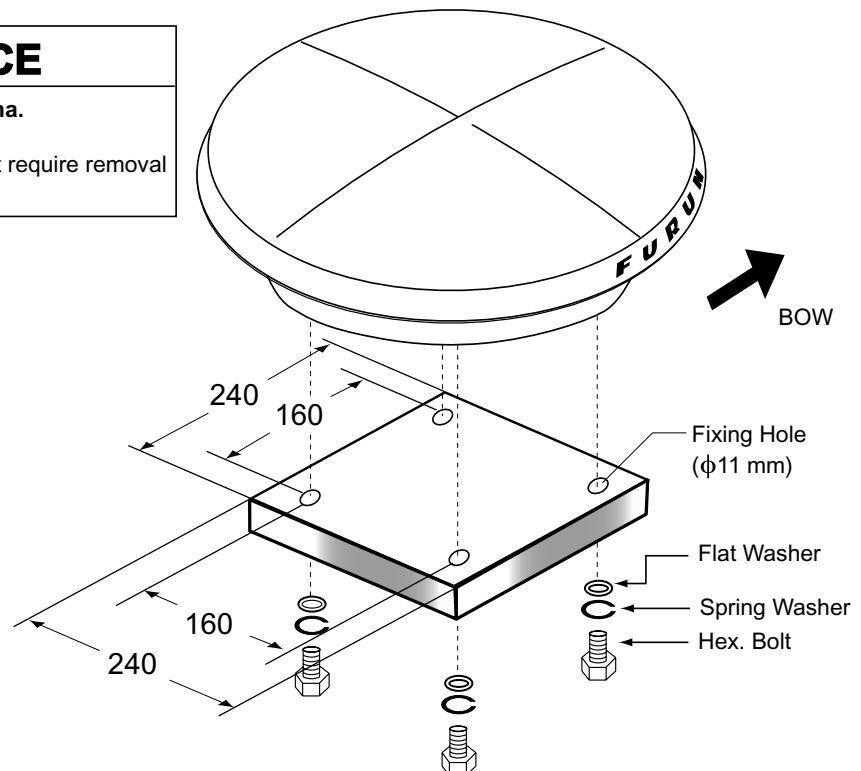

*Mounting dimensions for antenna, orienting the antenna*

3. Coat exposed parts of nuts, bolts and washers with silicone sealant.

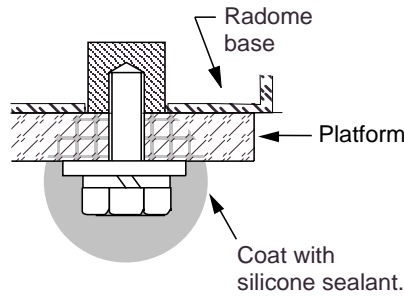

*Coating bolt, nut and washers with silicone sealant*

4. Connect the three coaxial cables coming from the antenna unit to the appropriate coaxial cables on the antenna cable, referring to the table below.

| Cable from antenna<br>(no. marked on cable) | Cable<br>TTPX6-3D2V-15M |
|---|-------------------------|
| ANT 1                                       | No color                |
| ANT 2                                       | Yellow                  |
| ANT 3                                       | Red                     |

5. Cover the antenna connectors with vulcanizing tape and vinyl tape, for waterproofing. Tie tape ends with a cable tie.

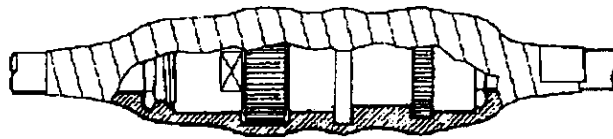

*Waterproofing the antenna connector*

6. Set the joints of the coaxial cables into the cavity in the antenna base.
7. Pass two cable ties (long life, temperature resistant type, local supply) through the hole shown in the figure below. Fasten them at the locations shown in the figure below.

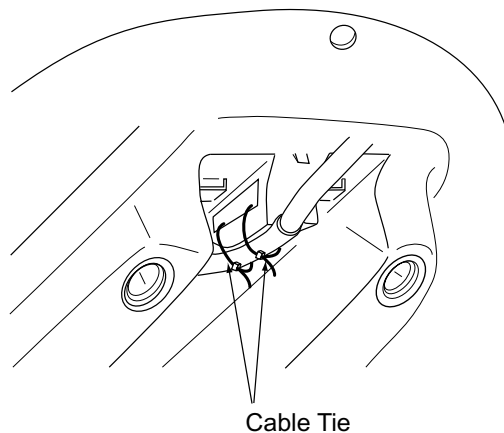

*How to fasten the antenna cable*

## 2. INSTALLATION

8. Set the “cable cover” to the antenna base as shown in the figure below.

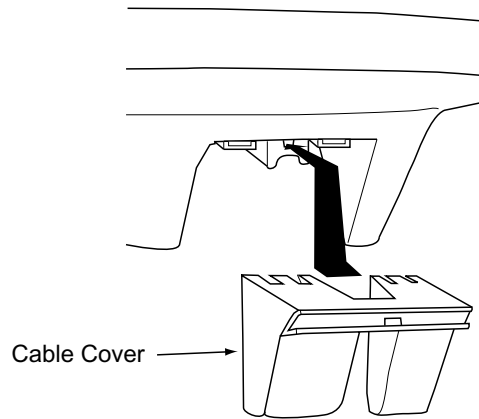

*How to insert the cable cover*

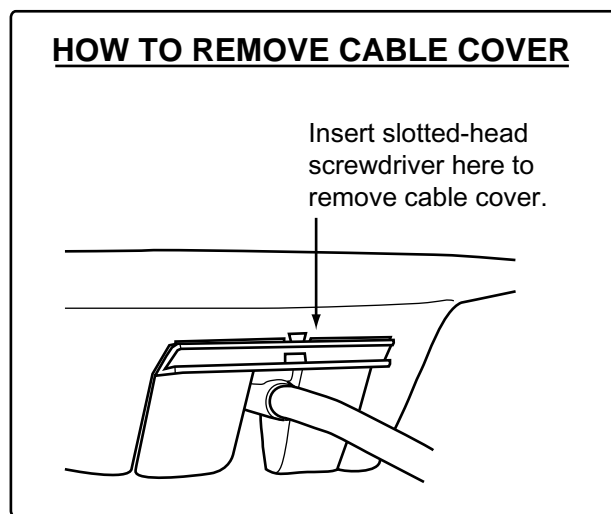

9. If necessary, attach nine “bird-repellent fixtures” (supplied) to the antenna cover as shown below. Use the paper pattern to position the fixtures.

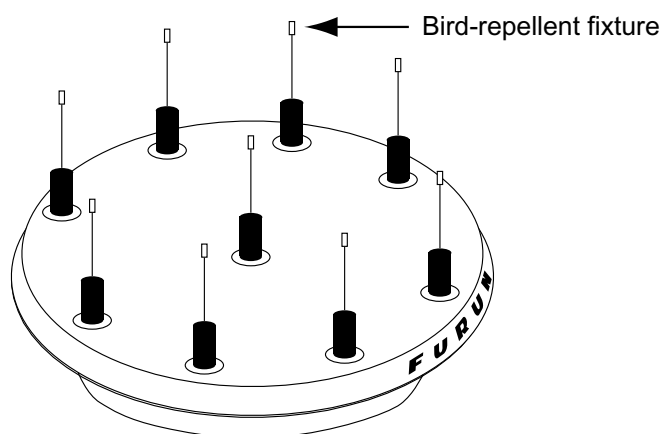

*Antenna unit*

## 2.2.2 DGPS antenna unit

Choose a mounting location for the DGPS antenna considering the points mentioned below. DGPS is not necessary for heading determination, however it can improve the accuracy of GPS position fixing

- Separate the DGPS antenna at least three meters from a radio antenna.
- Do not install the DGPS antenna within the radar beam.

1. Mount the DGPS antenna by one of the methods below.

- Screw it into a one-inch threaded pipe.
- Fasten it to a steel post ( $\phi 35$ - $\phi 90$ ) with stainless steel hose clamps (supplied).

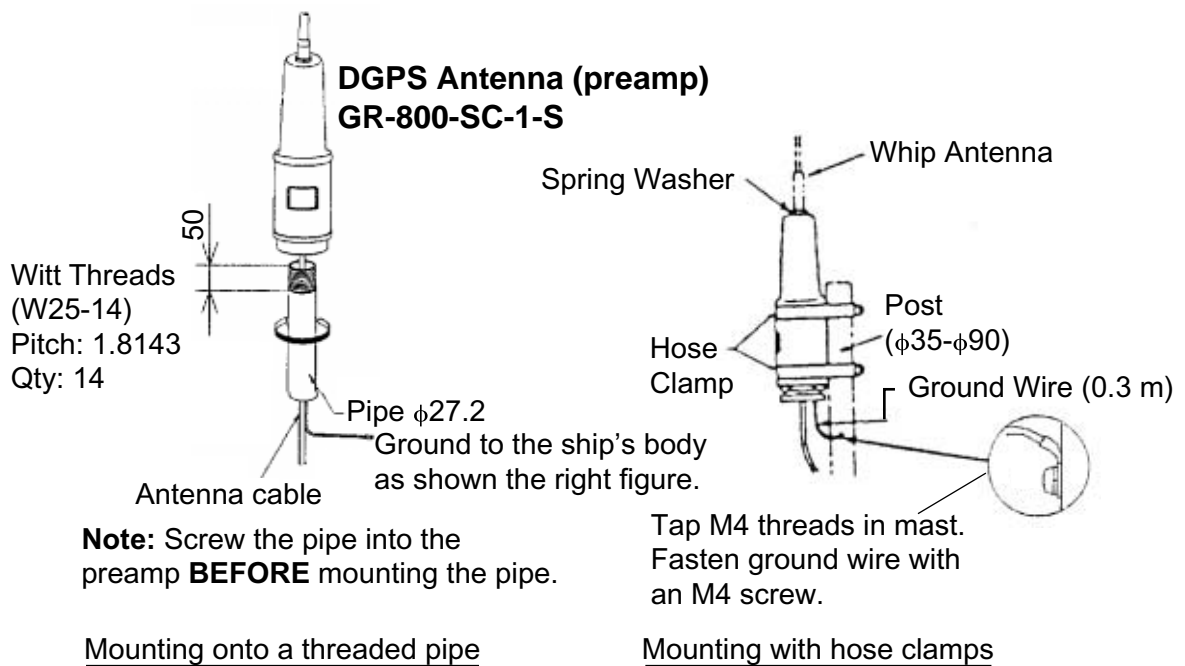

### *Mounting the DGPS antenna*

2. Set the spring washer to the whip antenna and screw the whip antenna into the antenna housing. Coat the washer with silicone sealant to prevent loosening.
3. Tap M4 threads on the post and fasten the ground wire with an M4 screw.

## 2. INSTALLATION

4. The DGPS antenna is supplied with a 15 m cable. If extension is necessary, use the extension cable (option). Cover the extension connector with vulcanizing tape and vinyl tape, for waterproofing. Tie tape ends with a cable tie.

Extension Cable: Type: OP08-15-30, Code No.: 004-396-440 (30 m)  
 Type: OP08-15-60, Code No.: 004-396-450 (60 m)

| Name      | Type           | Code No.    | Qty | Remarks                      |
|-----------|----------------|-------------|-----|------------------------------|
| Connector | TNC-SA-JJ      | 000-139-113 | 1   |                              |
| Cable     | TNC-PS-3D L30M | 000-139-078 | 1   | 30 m, connector at both ends |
|           | TNC-PS-3D L60M | 000-139-080 |     | 60 m, connector at both ends |

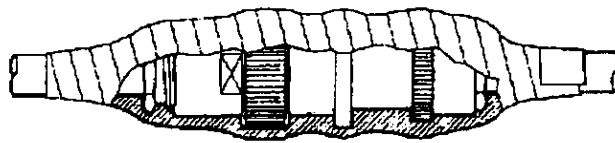

*Waterproofing the extension connector*

For cable RG-10UY (local supply, max. length 60 m), use the optional antenna cable set.

*Antenna cable set Type: OP08-17, Code No.: 004-392-510*

| Name                  | Type         | Code No.    | Qty | Remarks |
|-----------------------|--------------|-------------|-----|---------|
| Converter Cable Assy. | NJ-TP-3DXV-1 | 000-123-809 | 2   |         |
| Connector             | TNC-SA-JJ    | 000-139-113 | 1   |         |
| Connector             | N-P-7        | 000-501-514 | 2   |         |

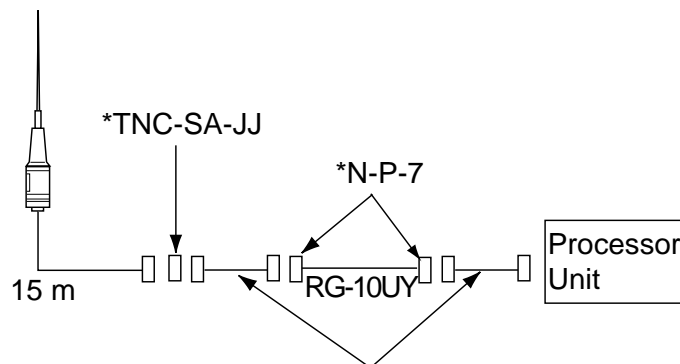

\* Converter cable assy. (supplied with antenna cable set)

*Cable connection when using cable RG-10UY*

## 2.3 Installing the Processor Unit

The processor unit should be mounted aligned with the ship's fore-and-aft line. It can be mounted on the deck, bulkhead, or on the underside of a desk. Choose a mounting location which allows you to easily view the power lamp on the top of the unit and which is within  $\pm 2.5^\circ$  of the ship's fore-and-aft line.

### 2.3.1 Deck mount

- The processor unit is factory adjusted for deck mounting. Fasten the processor unit to the mounting location with tapping screws (5 x 20, 4 pcs.). The unit can be oriented in one of the directions shown in the figure below. After the unit is installed, you will specify the mounting method from the menu.

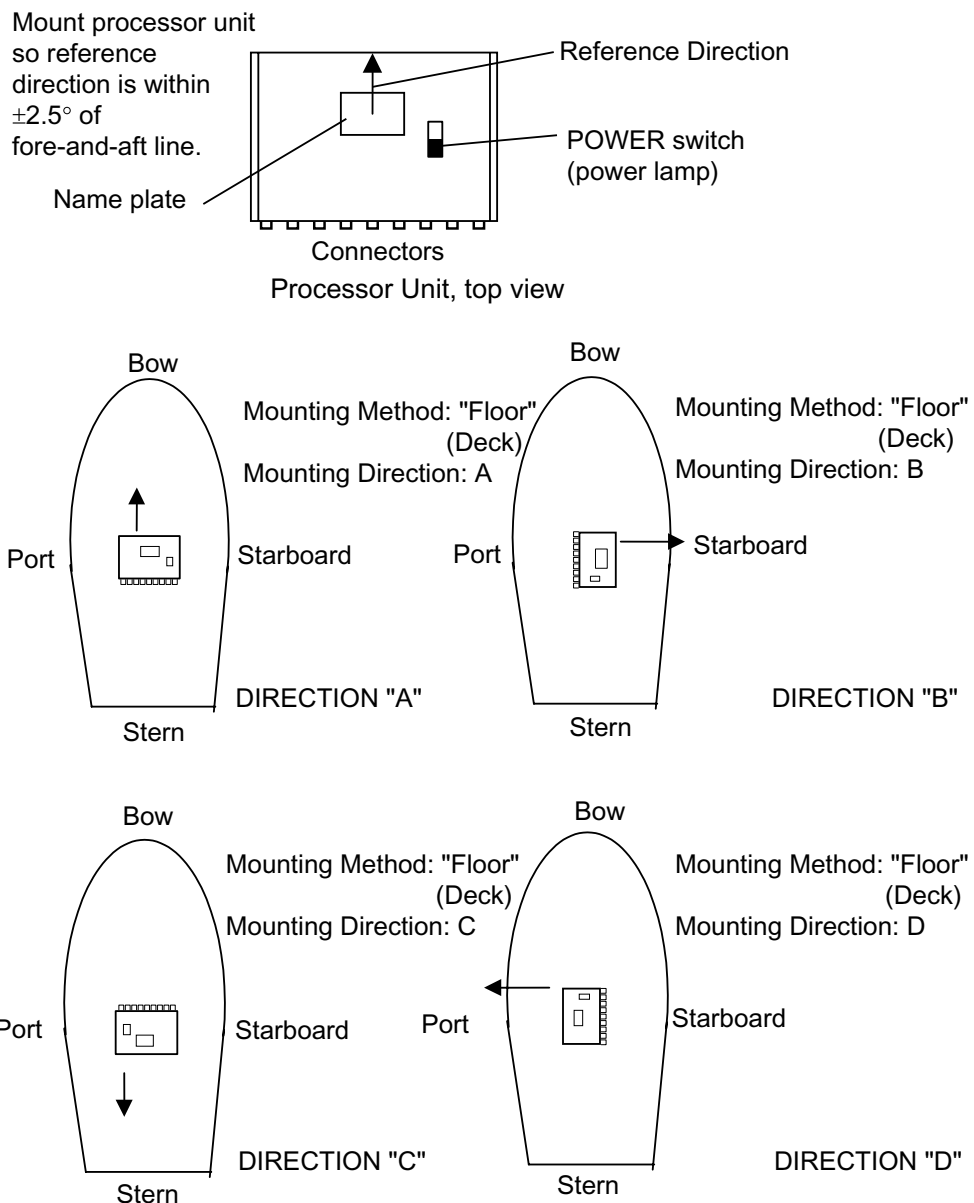

- Fasten the ground wire between the ground terminal on the processor unit and the ship's hull.

### 2.3.2 Bulkhead mount

For mounting on a bulkhead, use the bulkhead mounting plate supplied with the installation materials.

1. Unfasten four screws from the top cover to open the front panel.
2. Unfasten two screws to dismount the angular rate sensor.

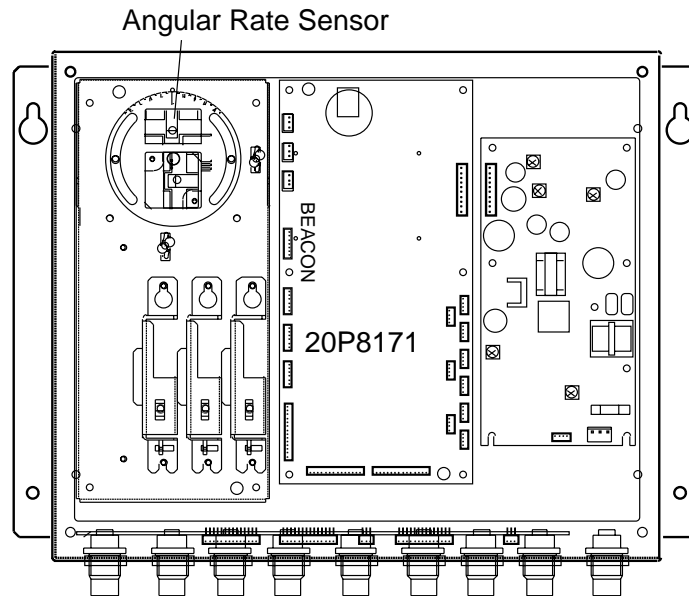

*Processor unit, top view*

3. Fasten the bulkhead mounting plate to the angular rate sensor. Align the center graduation on the sensor with the hole of the bulkhead mounting plate and tighten fixing screws.

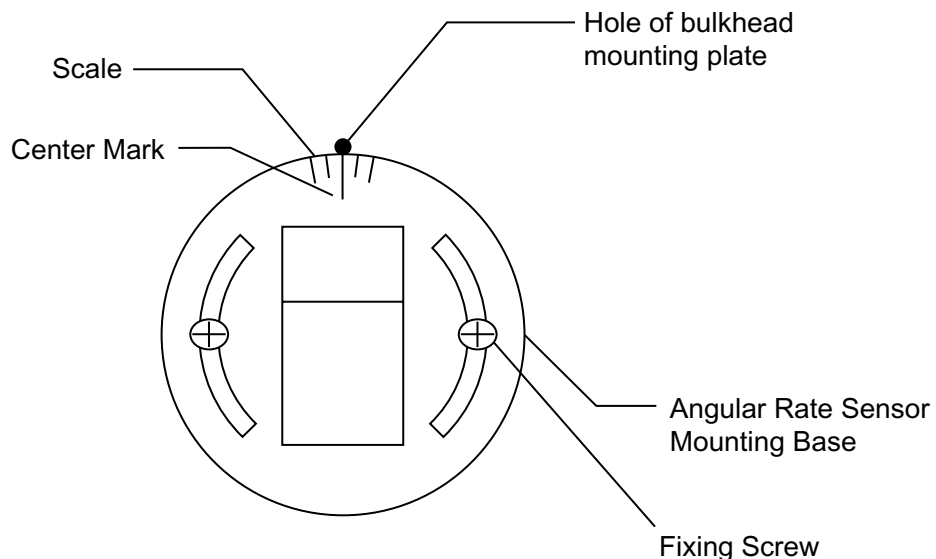

*Angular rate sensor, top view*



4. Loosen four screws on the angular rate sensor mounting base, and then fasten the bulkhead mounting plate to the angular rate sensor mounting base.

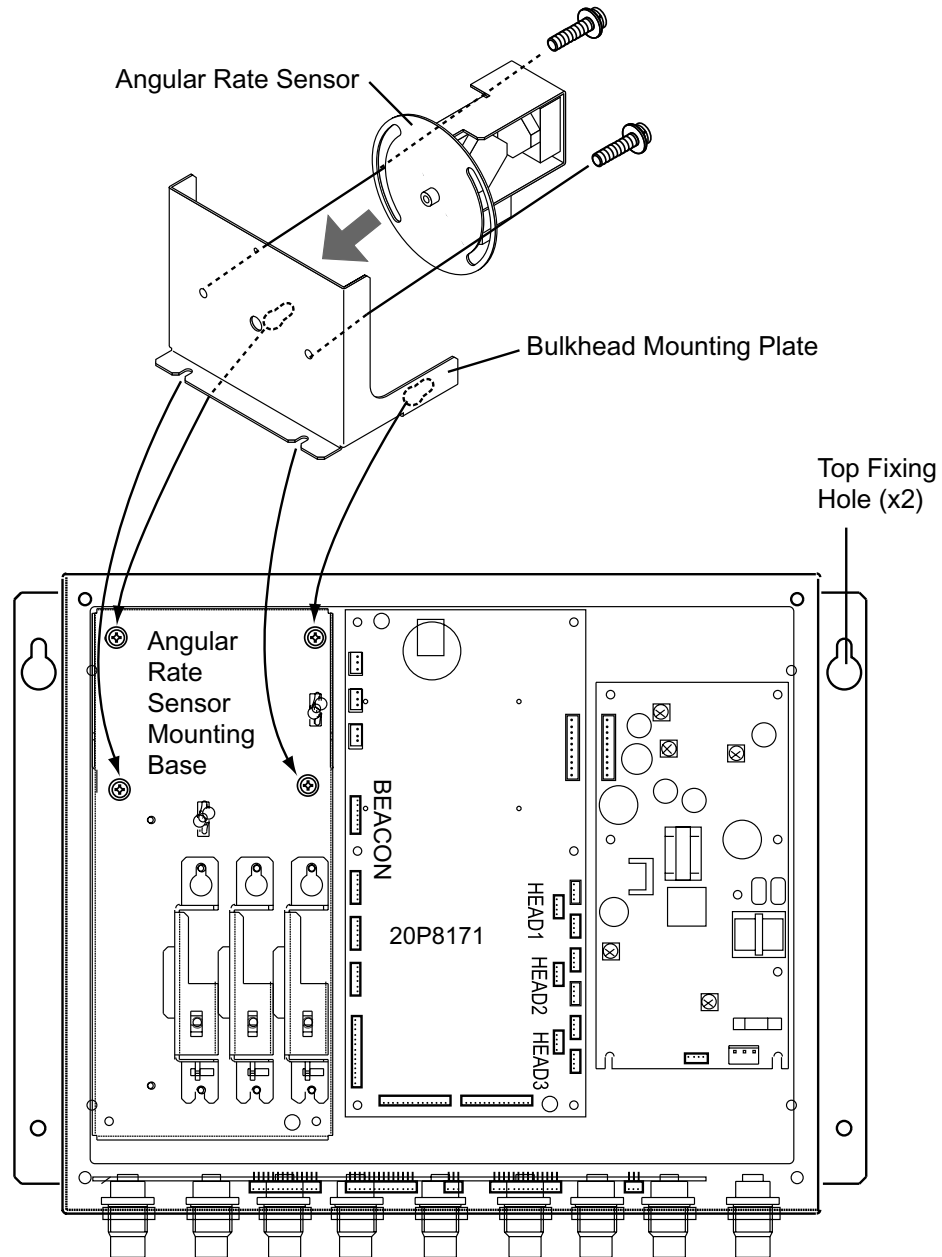

*Processor unit, top view*

5. Close the top cover of the processor unit.
6. Partially screw in two tapping screws for the top fixing holes of the processor unit in the mounting location. Hang the processor unit on the tapping screws, using the top fixing holes. Screw in two tapping screws for the bottom fixing holes, and then tighten the top fixing holes.

## 2. INSTALLATION

The unit can be oriented as shown in the figure below. After the unit is installed you will specify the mounting method from the menu.

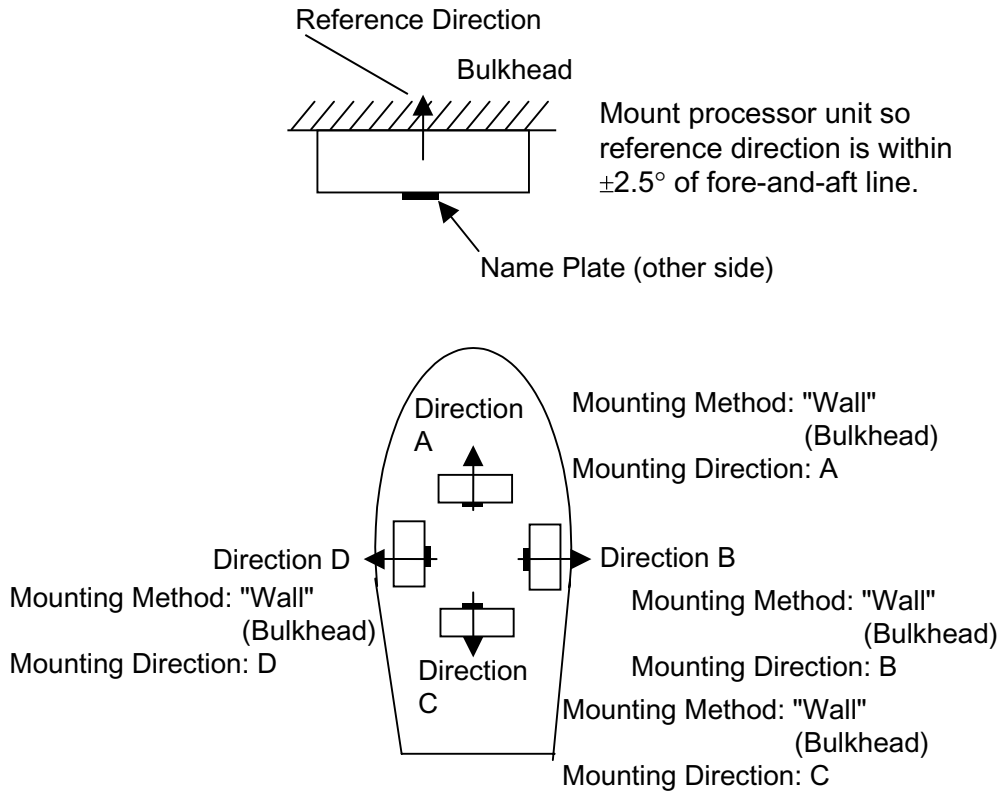

*Processor unit orientation, bulkhead mounting*

7. Fasten the ground wire between the ground terminal on the processor unit and the ship's superstructure.

### 2.3.3 Installation on the underside of a desk

The processor unit may be mounted on the underside of a desk as shown in the figure below. **Do not install it on the overhead.**

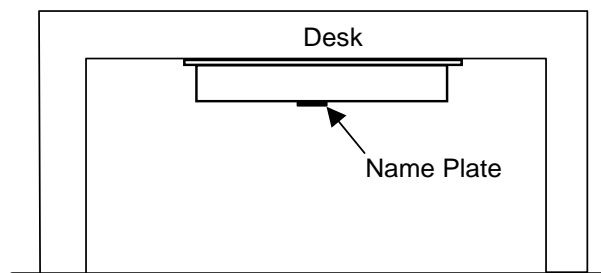

*Installation of processor unit on the underside of a desk*

The reference direction is as shown below. The mounting method is the same as that for mounting on the deck.

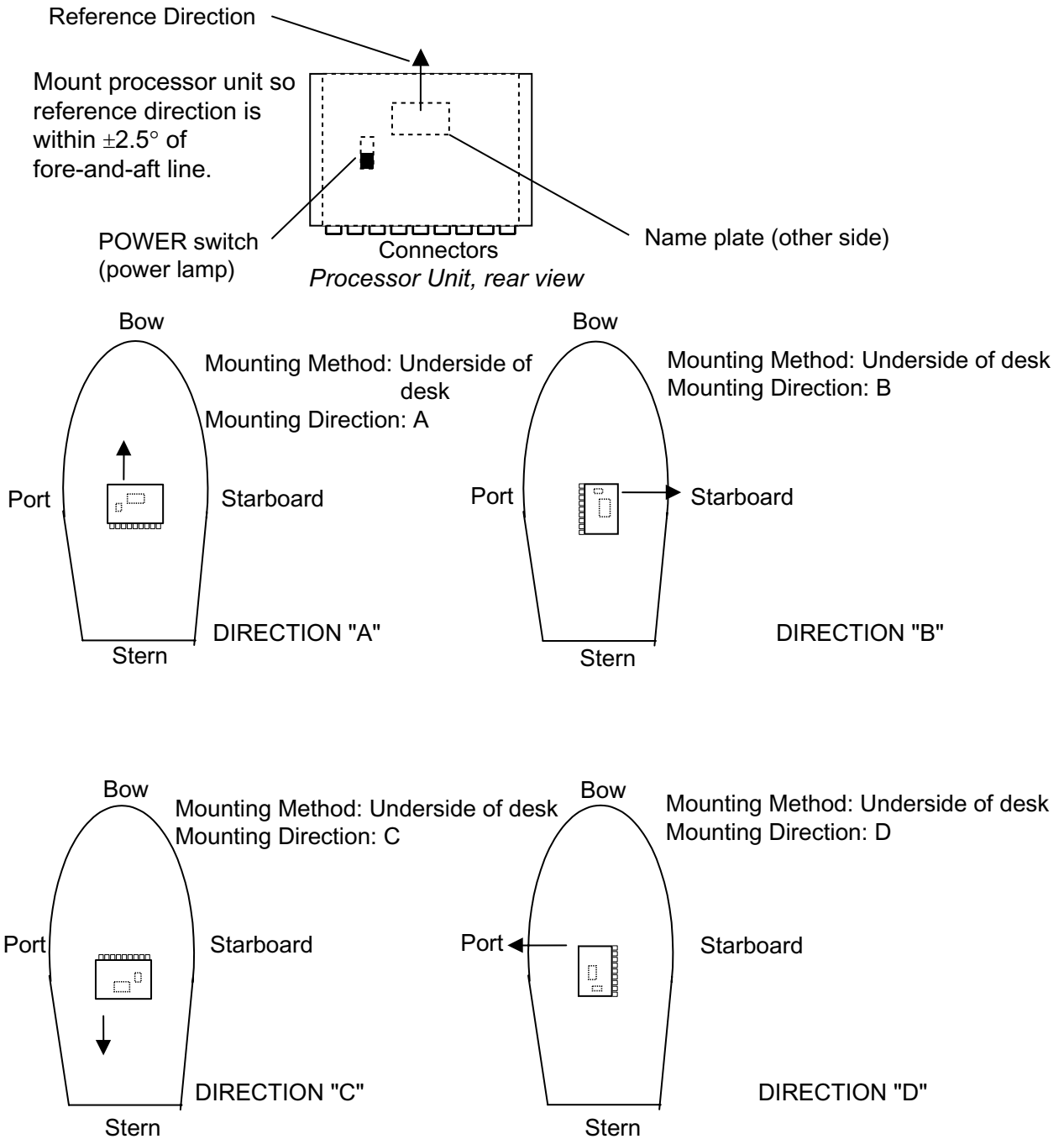

*Processor unit orientation, installation on the underside of a desk*

Mount the processor unit on a level surface with its name plate facing the bow, stern, port or starboard.

### 2.3.4 Adjusting for orientation error

It may be impossible to perfectly align the processor unit on the fore-and-aft or port-and-starboard line. Open the top cover, loosen the two fixing screws on the angular rate sensor and turn. For example, if the orientation error is 2.5° to port, rotate the sensor 2.5° starboard. The range of adjustment is -45° to +45°. Close the top cover after completing the adjustment.

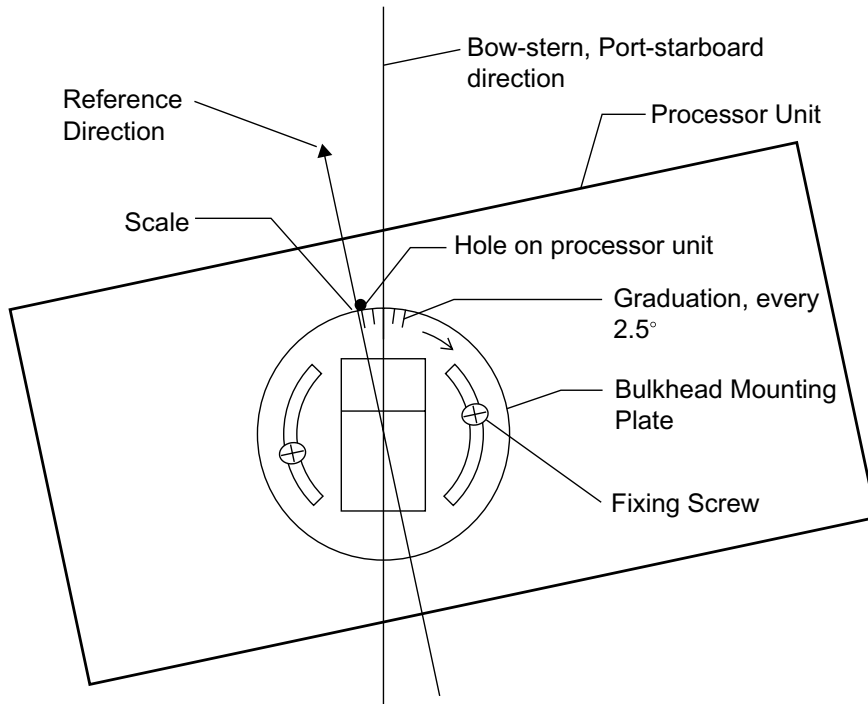

*Angular rate sensor, top view*

## 2.4 Installing the Display Unit

### 2.4.1 Desktop, overhead mounting

1. Fasten the hanger to the mounting location with four tapping screws (supplied). See the outline drawing for mounting dimensions.
2. Screw the knobs into the display unit.
3. Set display unit to the hanger and tighten the knobs.
4. Run the ground wire between the ground terminal on the display unit and the ship's superstructure.

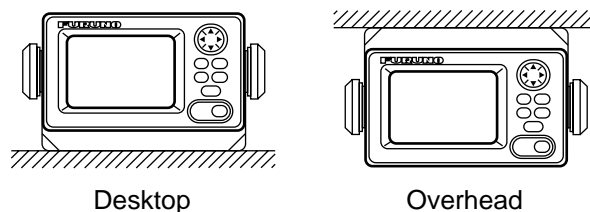

*Display unit mounting methods*

## 2.4.2 Flush mount

Two types of flush mounts are available. See the outline drawing at the back of the manual for details.

### Flush mount “F”

*Flush mount “F” kit Type: OP20-29, Code No: 000-041-405)*

| Name           | Type        | Code No.    | Qty |
|----------------|-------------|-------------|-----|
| Cosmetic Panel | 20-016-1051 | 100-251-370 | 1   |
| Tapping Screw  | 5X20        | 000-802-840 | 4   |
| Hex Bolt       | M6X12       | 000-862-127 | 2   |
| Spring Washer  | M6          | 000-864-260 | 2   |

1. Make a cutout in the mounting location. The dimensions are 183(W) x 92(H) mm.
2. Fasten the cosmetic panel to the display unit with hex bolts and flat washers.
3. Fasten the display unit to the mounting location with tapping screws.

### Flush mount “S”

*Flush mount “S” kit Type: OP20-17, Code No.: 000-040-720)*

| Name                | Type        | Code No.    | Qty |
|---------------------|-------------|-------------|-----|
| Flush Mount Fixture | 20-007-2401 | 100-183-190 | 2   |
| Wing Bolt           | M4X30       | 000-804-799 | 4   |
| Wing Nut            | M4          | 000-863-306 | 4   |
| Hex Bolt            | M6X12       | 000-862-127 | 2   |
| Spring Washer       | M6          | 000-864-260 | 2   |

1. Make a cutout in the mounting location. The dimensions are 167(W) x 92(H) mm.
2. Place the display unit in the cutout.
3. Fix the display unit to the two flush mount fixtures with hex bolts and spring washers.
4. Screw the butterfly nut on the butterfly bolt.
5. Fix the display unit with the butterfly bolt and then tighten the butterfly nut.

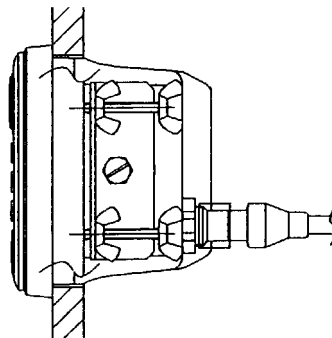

*Flush mount “S”*

## 2.5 Wiring

This section covers general wiring. For further details see the interconnection diagram at the back of this manual.

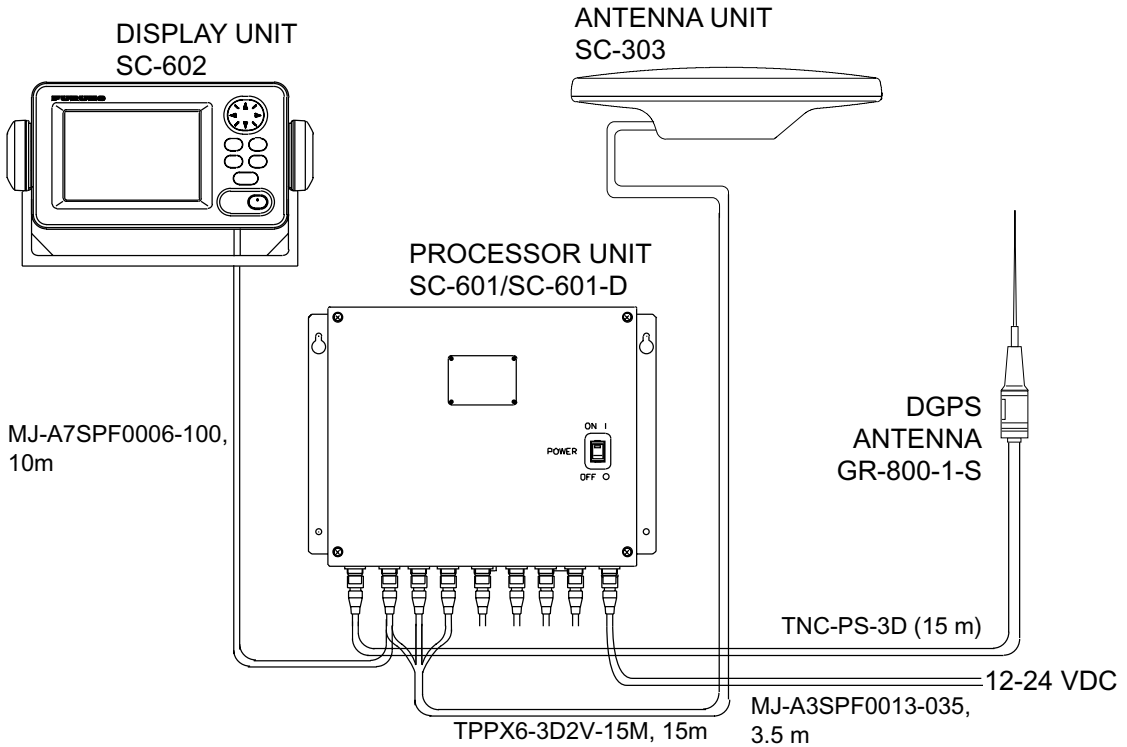

*General wiring diagram*

- The display cable (display and processor units) is 10 m long. Connect it to the DISPLAY port on the processor unit.
- The antenna cable is 15 meters (standard length). Connect the three coaxial cables to the processor unit according to cable color as below. Incorrect connection will result in wrong heading.

| Antenna           | TPPX6-3D2V-15M | Port on Processor Unit |
|-------------------|----------------|------------------------|
| Antenna Element 1 | No color       | GPS ANT 1              |
| Antenna Element 2 | Yellow         | GPS ANT 2              |
| Antenna Element 3 | Red            | GPS ANT 3              |

**Note 1:** Instead of TPPX6-3D2V, three Japan Industrial Standard coaxial cables 3D2V (local supply) or equivalent can be used as antenna cables.

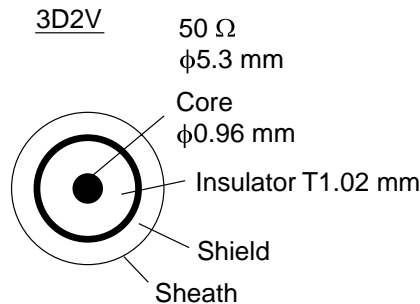

*Sectional view of coaxial cable 3D2V*

**Note 2:** The optional antenna cable set (CP20-01700 or CP20-01710, 3 sets) allows you to extend antenna cable length to 30 m (50 m). See next page for how to attach the connector.

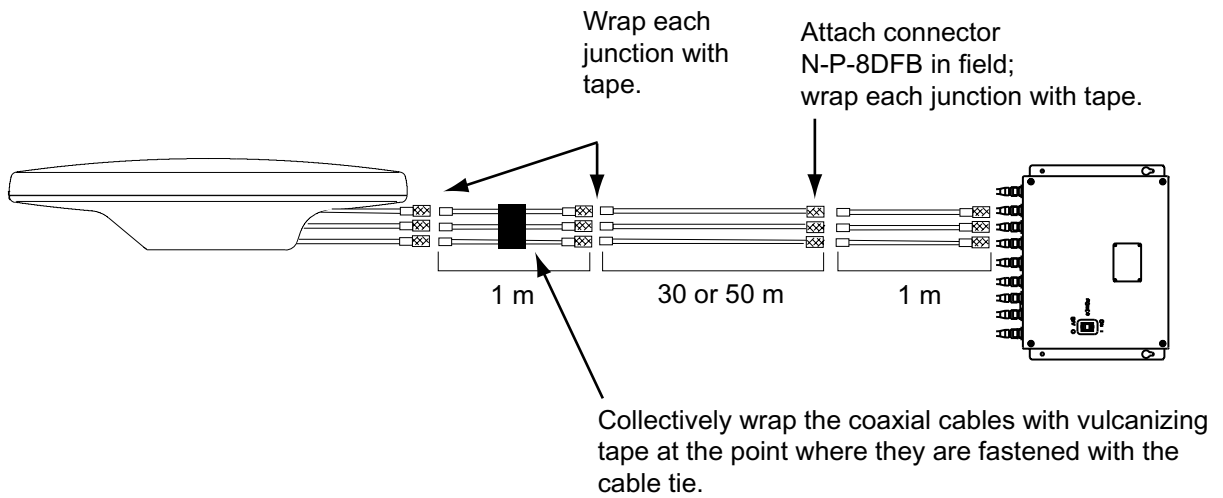

*How to install the optional antenna cable set*

**How to attach connector N-P-8DFB**

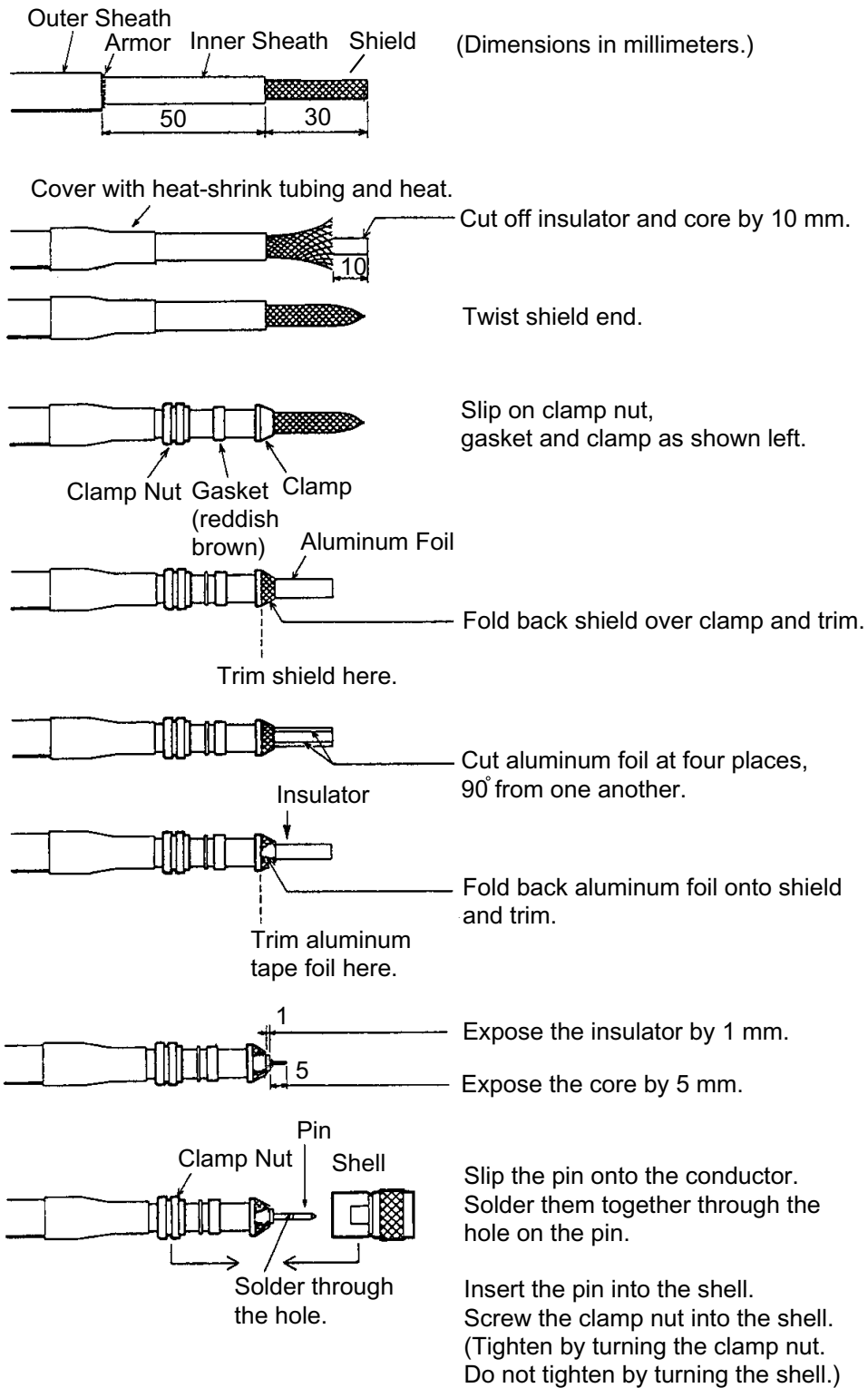

*How to attach connector N-P-8DFB*

- Connect the DGPS antenna cable to the BEACON ANT port on the processor unit. The standard cable is 15 m long. With the optional extension cable the cable can be extended to 30 m or 60 m.



## 2.6 Initial Settings

Follow the procedures in this section to enter initial settings.

|   |
|---|
|  <b>NOTICE</b>                     |
| Improper menu settings may stop output of data and display the message "RATE ERROR." Be sure to enter correct data. |

### 2.6.1 Confirming satellite status; choosing mounting method

1. Turn on the processor unit and press the [MENU] key to show the menu.

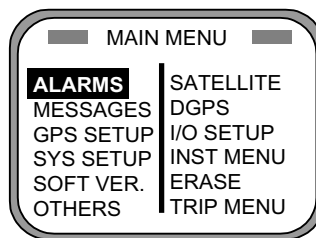

*Main menu*

2. Use the Omnipad (⊕) to choose "INST MENU" and press the [ENT] key.

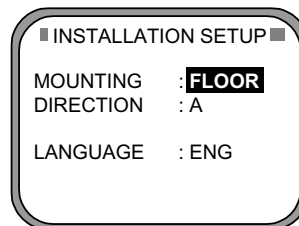

*Installation setup menu*

3. Confirm that "MOUNTING" is selected and press the [ENT] key.
4. Use the Omnipad to choose the mounting method: "FLOOR", "WALL" or "INVERT" as appropriate.
5. Press the [ENT] key.
6. Choose "DIRECTION" and press the [ENT] key.
7. Use the Omnipad to choose mounting direction ("A", "B", "C" or "D") as appropriate. Refer to section 2.3.1.
8. Press the [ENT] key.
9. Press the [SAT STATUS] key.

Satellites used for measurement

| SAT TRACKING STATUS      |        | OK   |             |
|--------------------------|--------|------|-------------|
| TIMER                    | 5 '52" | NO.  | GOOD STATUS |
| Satellites being tracked |        | GPS1 | 8 8 D3D     |
|                          |        | GPS2 | 7 7 D3D     |
|                          |        | GPS3 | 8 8 D3D     |

"OK" displayed when the "GOOD" column shows that the number of satellites acquired is five or more.

"3D" shown when no beacon receiver is used.

*Satellite tracking status display*

## 2. INSTALLATION

When the system is turned on for the first time it is in the “cold start” state, which means there is no satellite data (almanac data) stored. In this condition it takes about 20 minutes to find heading, indicated by displaying “OK.” (Once almanac data is stored it takes about five minutes to find heading.) The timer at the top left corner of the screen shows time since power on. If OK is not displayed within 30 minutes after turning on the power, the antenna mounting location may not be suitable. It is suspected that the number of satellites in view is less than five due to signal blockage. Clear the problem and then check status on the status display.

If the heading error is between 5° and 10°, loosen the nut at the center of the antenna unit and adjust antenna orientation, while watching the heading indication on the display.

### 2.6.2 Choosing heading source

Choose the source of heading data as below.

 **CAUTION**

**1. Never switch from internal to external heading while the autopilot is in the automatic mode. Change to the manual mode before switching.**

**2. The data of external heading must come from type-approved sensor, in case of SOLAS vessel.**

1. Press the [HDG SETUP] key.

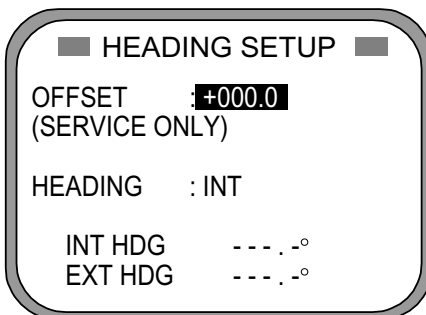

- OFFSET : Heading offset. See service manual for instructions. "SERVICE ONLY" means heading offset shown for display only.
- HEADING : Select heading source. Choose INT for normal use. If a gyrocompass is connected for primary means, leaving this equipment as backup, choose EXT.
- INT HDG : Bow heading. Includes offset.
- EXT HDG : Heading fed from external equipment.

#### *Heading setup menu*

2. Use the Omnipad to choose HEADING.
3. Press the [ENT] key.
4. Choose INT or EXT as appropriate. Normally choose INT. If own GPS sensor is not working and a heading sensor such as a gyrocompass is available, choose EXT.
5. Press the [ENT] key.
6. Press the [DISP] key to close the menu.

### 2.6.3 Heading data format

1. Turn off the processor unit.
2. Unfasten four screws from the processor unit to remove the top cover.
3. Choose the heading format of the equipment connected to the ports HDG OUT 1, HDG OUT 2 and HDG OUT 3 with the jumper wires on the circuit board 20P8171, referring to the table below. The default setting for each port is AD-10.

*Jumper wire and format on the circuit board 20P8171*

| Port      | Format | Setting        | Remarks  |
|-----------|--------|----------------|--|
| HDG OUT 1 | AD-10  | J11 < - > J13  | NMEA and AD-10 are identified on the circuit board. Choose NMEA for IEC 61162-1 sentences. |
|           | NMEA   | J11 < - > J12  |  |
| HDG OUT 2 | AD-10  | J14 < - > J16  |  |
|           | NMEA   | J14 < - > J15  |  |
| HDG OUT 3 | AD-10  | J17 < - > J19  |  |
|           | NMEA   | J 17 < - > J18 |  |

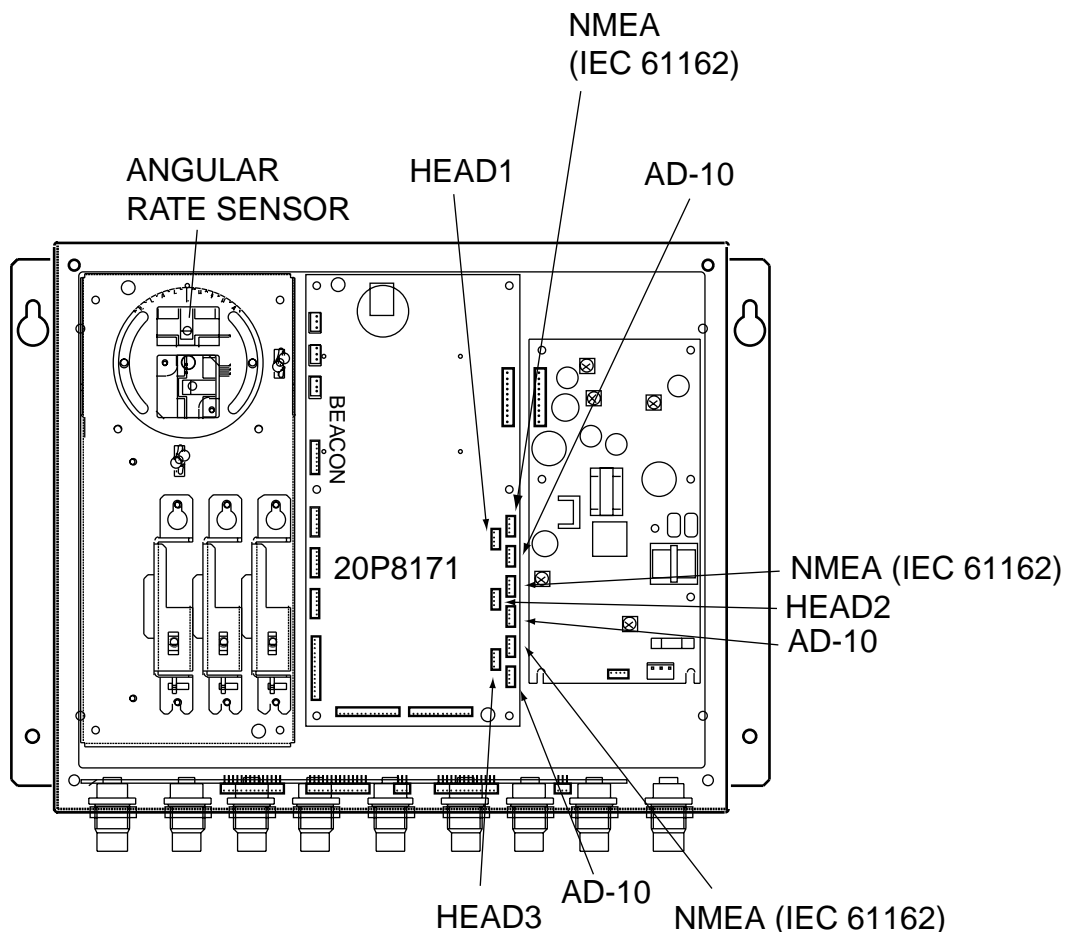

*Processor unit, cover opened, top view*

## 2.7 Connection of External Equipment

All external equipment are terminated on the rear panel of the processor unit.

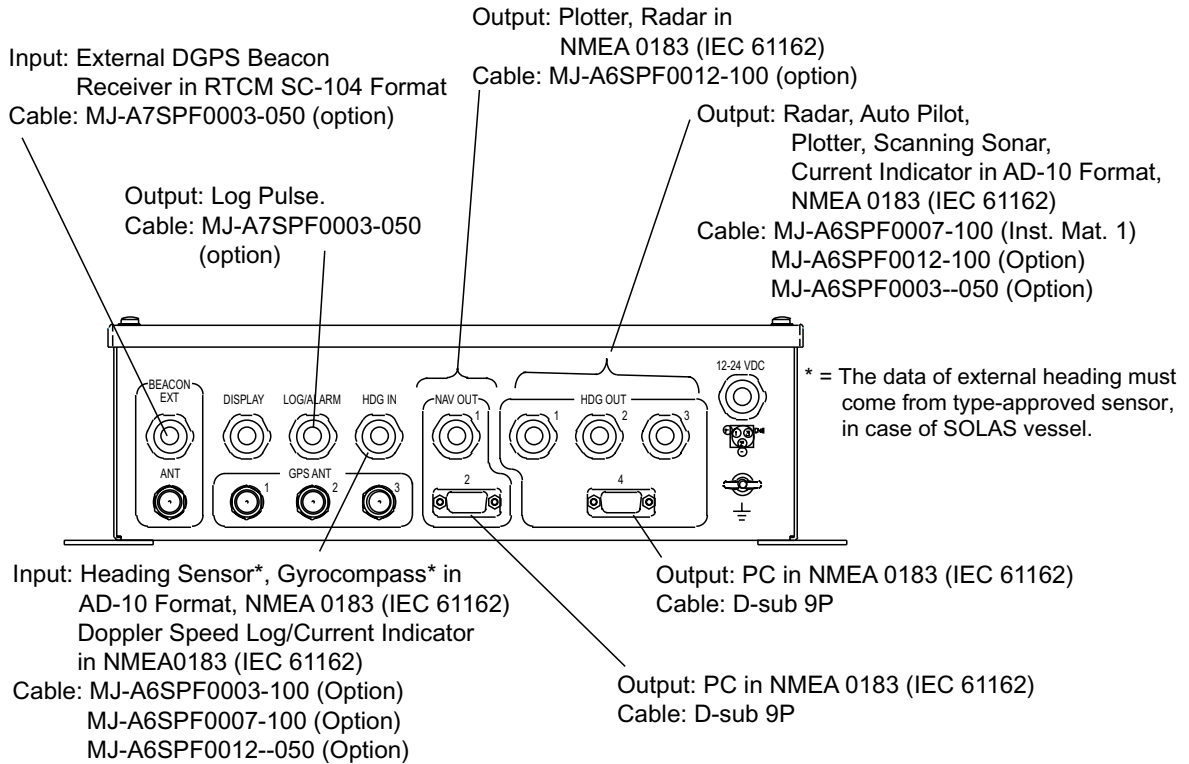

### External heading input format and output sentence

AD-10: Header of IEC 61162 data sentence chosen on menu is output.

IEC 61162: When EXT data is output from this equipment, NMEA Header (Identifier) of the external data is output as it is without changes.

*Processor unit, rear view*

## 2.8 Installing the DGPS Beacon Receiver Kit

The optional DGPS beacon receiver provides DGPS capability. The beacon receiver assy. is installed in the processor unit. A DGPS antenna is necessary.

DGPS Beacon Receiver Kit

Type: GR-7001-K Code No. 000-041-738

| Name                | Type         | Code No.    | Qty | Remarks                  |
|---------------------|--------------|-------------|-----|--------------------------|
| Antenna             | GR-8         | 000-040-660 | 1   |                          |
| Hose Clamp          | SS7200N      | 000-570-239 | 2   |                          |
| Spring Washer       | M10          | 000-864-261 | 1   |                          |
| DGPS Receiver Assy. | SC-601       | 004-377-860 | 1   |                          |
| Cable Assy.         | TNCBPJ(140)  | 000-143-748 | 1   | w/toothed washer and nut |
| PH Connector        | 20-061(7-6P) | 004-377-770 | 1   |                          |
| Panhead Screw       | M3X8         | 000-881-404 | 4   |                          |
| DGPS Station List   | J49-80010    | 000-808-435 | 1   |                          |
| Whip Antenna        | FAW-1.2      | 000-130-046 | 1   |                          |
|                     | 04S4176      | 000-112-845 |     |                          |

**Procedure**

1. Open the top cover of the processor unit.
2. Open the cover of the DGPS receiver assembly.
3. Connect the cable TNCBPJ(140) to J1 on the DGPS receiver assembly.
4. Remove the plug at the rear of the processor unit.
5. Pass the cable TNCBPJ(140) through the hole made at step 4 and fasten it with toothed washer and nut.
6. Fasten the DGPS receiver assembly at the location shown below.

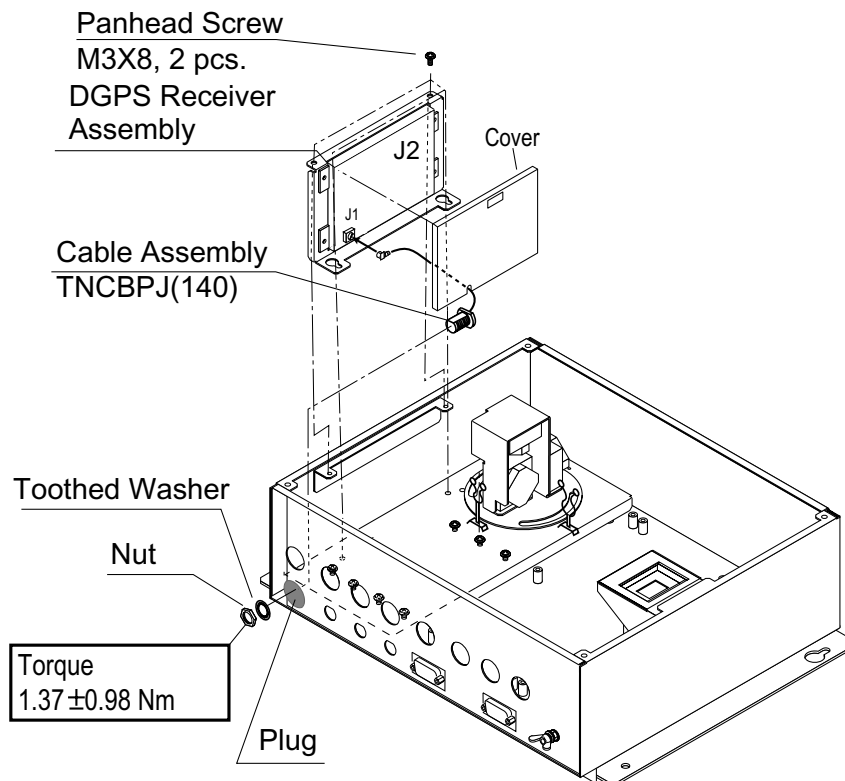

*Processor unit, cover removed, top view*

7. Connect the 6P connector of the PH connector 20-061(7-6P) to J2 on the DGPS receiver assy.
8. Connector the 7P connector of the PH connector 20-061(7-6P) to J10 on the circuit board 20P8171.

## 2. INSTALLATION

9. Fix the PH connector assy. with a clamp as shown below.

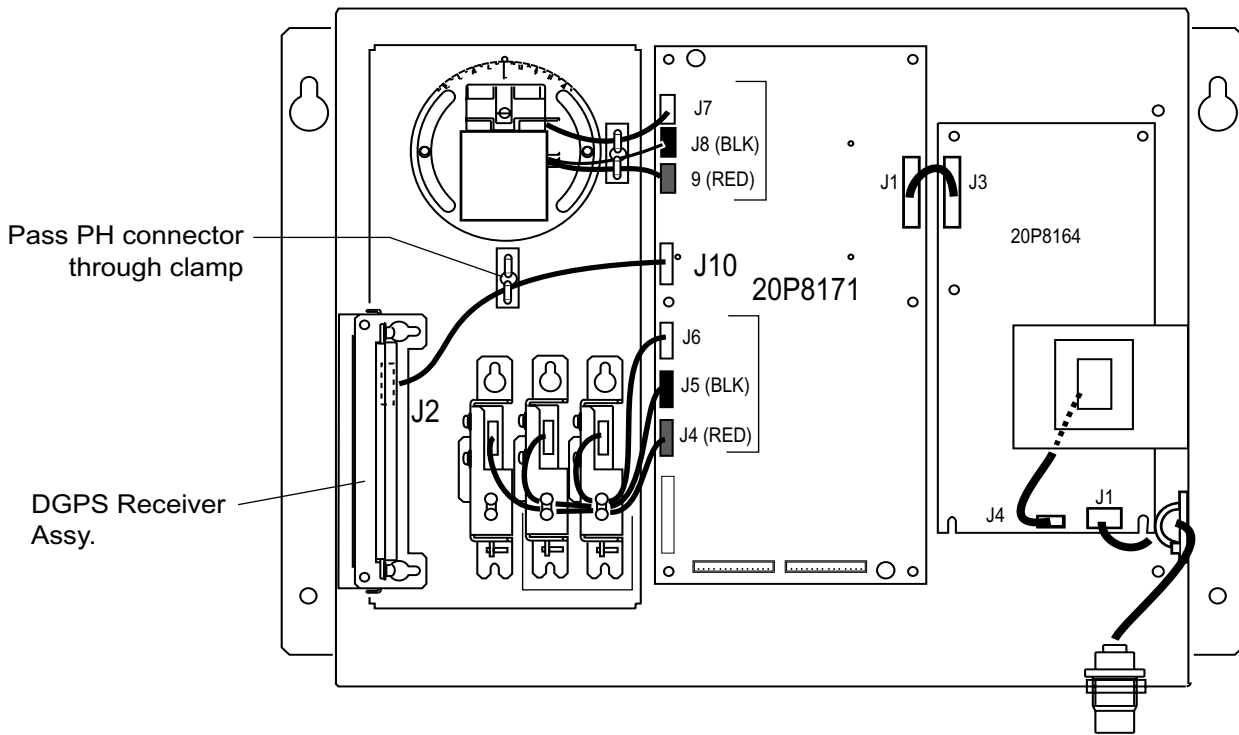

*Processor unit, cover removed, top view*

10. Close the top cover of the processor unit.

11. Mount the DGPS antenna and whip antenna, referring to section 2.2.2.

# 3 OPERATION

## 3.1 Controls

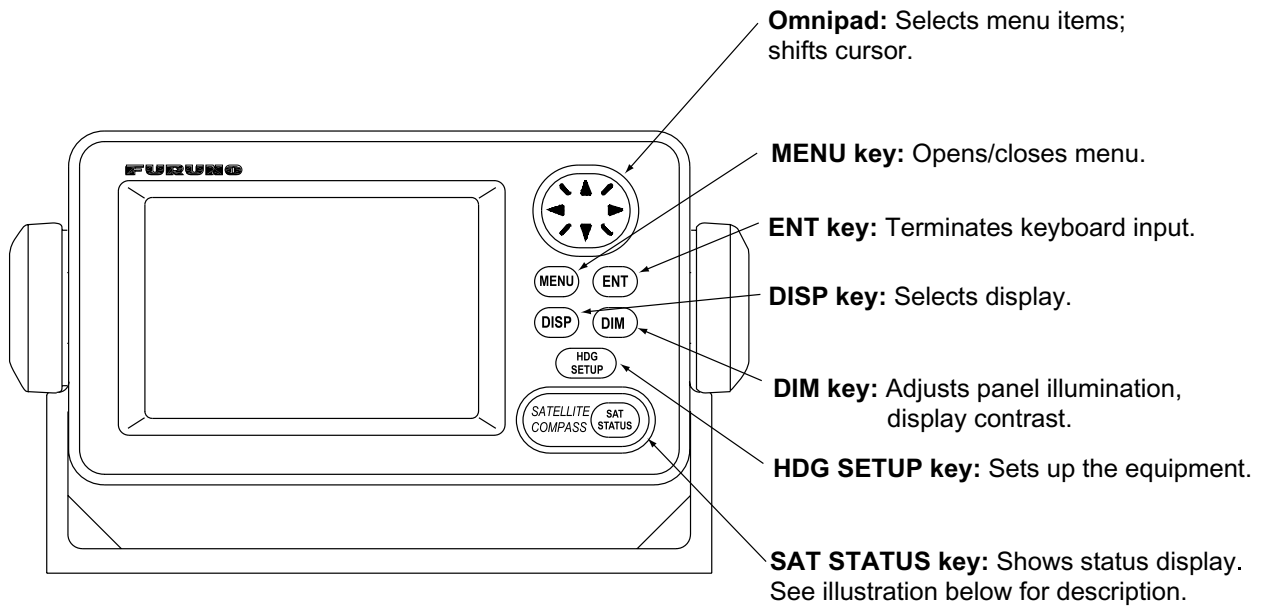

### HOW TO REMOVE THE COVER

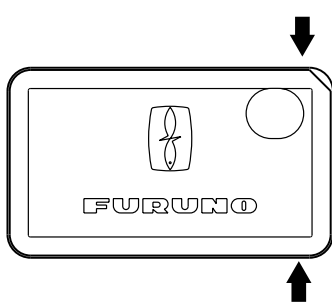

Press here and pull toward you to remove cover.

Satellites used for measurement

| SAT TRACKING STATUS      |     |      |        |
|--------------------------|-----|------|--------|
| TIMER 5 '52"             |     |      |        |
| Satellites being tracked | NO. | GOOD | STATUS |
| GPS1                     | 8   | 8    | D3D    |
| GPS2                     | 7   | 7    | D3D    |
| GPS3                     | 8   | 8    | D3D    |

"OK" displayed when the "GOOD" column shows that the number of satellites acquired is five or more.

"3D" shown when no beacon receiver is used.

Display unit



### CAUTION

Reduced accuracy may occur in case of unfavorable satellite constellation, worsened HDOP, etc.

Always confirm position against other navigation devices to verify reliability.

## 3.2 Turning the Power On/Off

Use the power switch on the processor unit to turn the power to the display unit on and off.

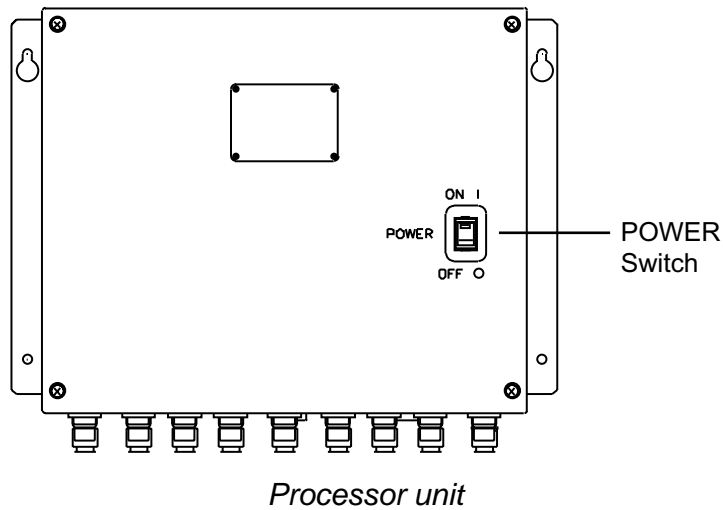

The display starts up with the last-used display. Below is the heading display.

**Note 1:** Turn on external equipment **AFTER** the SC-60 is showing reliable heading data, to prevent heading output error.

**Note 2:** The display flashes when backup heading data is being used.

## 3.3 Panel Illumination, Display Contrast

1. Press the [DIM] key.

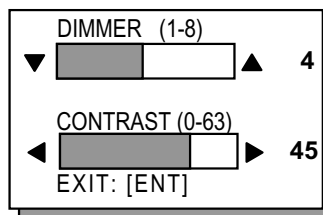

*Dialog box for adjustment of panel illumination, display contrast*

2. Press ▲ or ▼ on the Omnipad to adjust panel illumination.
3. Press ◀ or ▶ on the Omnipad to adjust display contrast.
4. Press the [ENT] key.



### 3.4 Choosing a Display

Use the [DISP] key to show a display desired.

#### 3.4.1 Description of displays

##### Heading display

The heading display shows heading, course, speed, date, time and position-fixing method. The heading status mark changes in the sequence shown below. The “final calculations” mark disappears after heading becomes reliable, which is approximately 90 seconds after that mark appears.

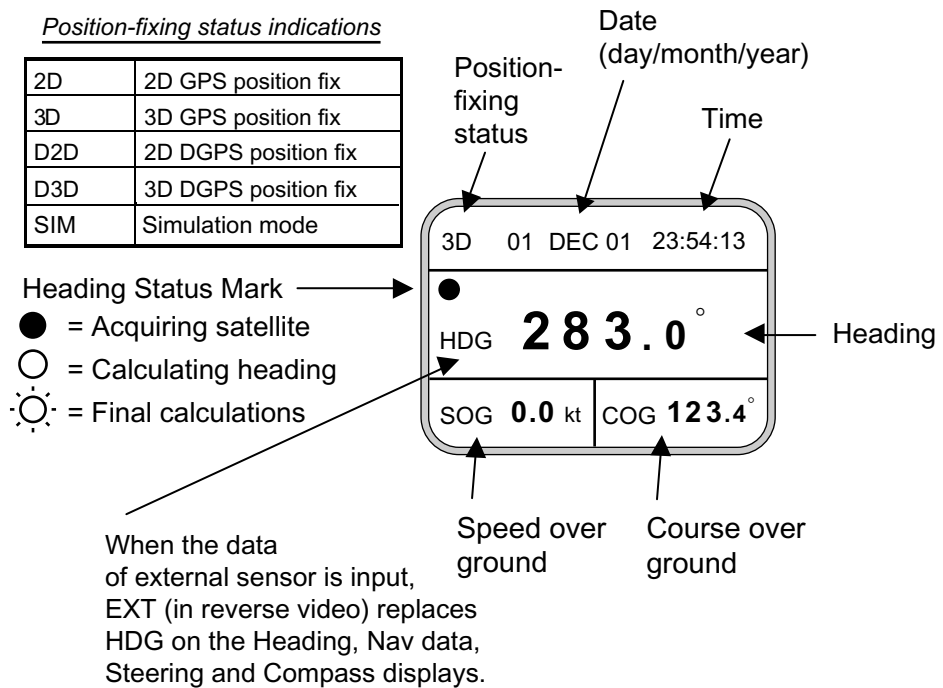

##### Nav data display

The nav data display shows position in latitude and longitude, course, speed, date, time and position-fixing method.

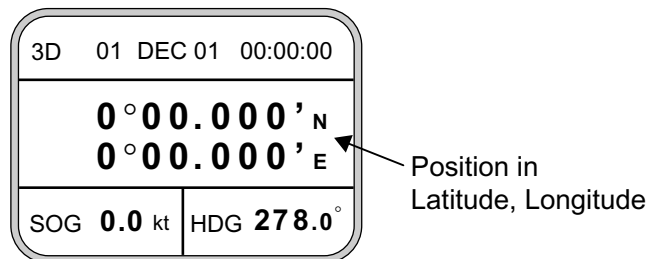

*Nav data display*

**Steering display**

The steering display shows heading in digital and analog form. SOG and COG are also indicated. Note that COG accuracy is low when the own ship speed is low. The faster the speed, the more accurate the COG.

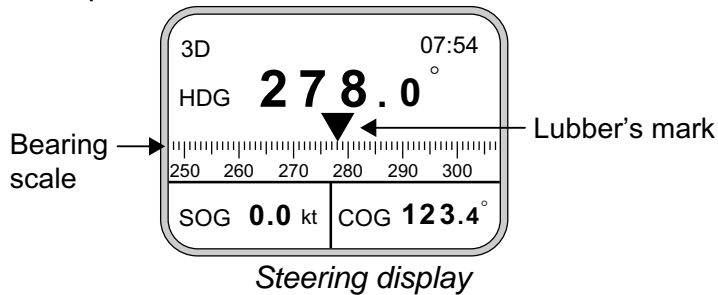

**Compass display**

The compass display shows heading by compass direction. Pitch and roll are also indicated. The compass rose rotates with heading.

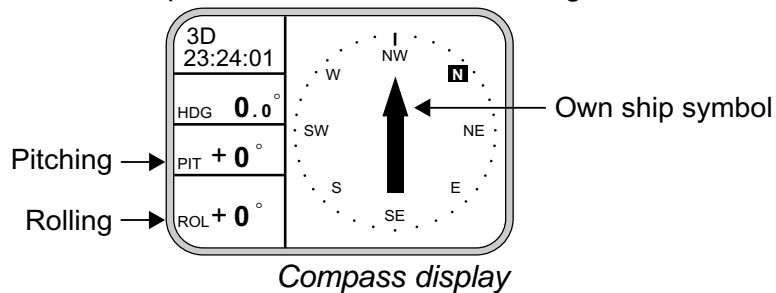

**ROT (Rate-of-Turn) display**

The ROT display provides digital and analog indications of rate of turn.

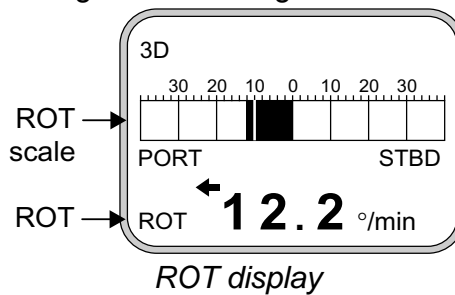

**Set and Drift display, Distance Run display**

Depending on the setting of DISTANCE DISP on the TRIP menu, the Set and Drift display or the Distance Run display is shown. The Set and Drift display requires the Doppler Speed Log DS-80 and it shows current direction and speed.

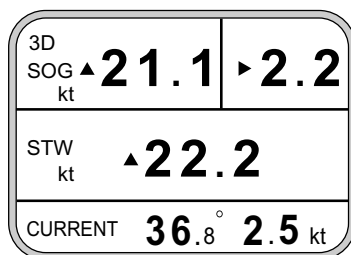

Set and Drift display

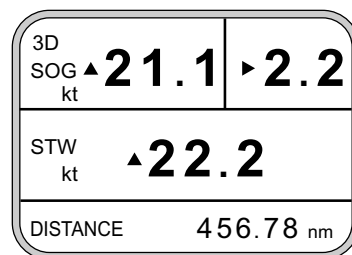

Distance Run display

*Set and drift display, speed and distance run display*

## 3.5 Alarms

The SC-60 can alert you with audio and visual alarms when GPS data and DGPS data are lost. To set the alarm mode;

1. Press the [MENU] key to show the menu.

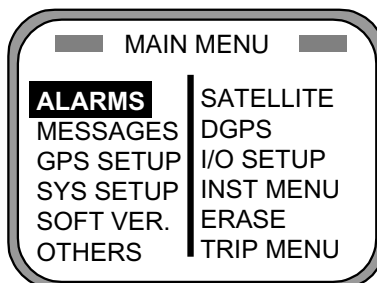

*Main menu*

2. Choose ALARMS and press the [ENT] key.

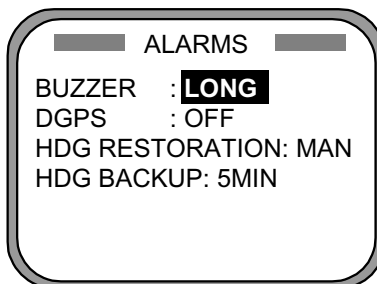

*Alarm menu*

3. Press the [ENT] key.

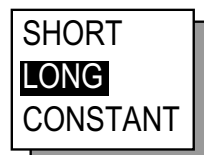

*Alarm menu, GPS buzzer options*

4. Use ▲ or ▼ on the Omnipad to choose buzzer type desired.

SHORT: Two short beeps

LONG: Three long beeps

CONSTANT: Continuous beep

5. Press the [ENT] key.
6. Choose DGPS, HDG RESTORATION or HDG BACKUP as appropriate.

**DGPS:** Turns on/off DGPS alarm.

**HDG RESTORATION:** Choose how to restore GPS signal, automatically or manually.

**HDG BACKUP:** Choose how long to wait before stopping output of heading, when GPS signal is lost.

7. Press the [ENT] key.

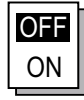

DPGS options HDG RESTORATION options

*Alarm menu, DGPS buzzer options*

7. Choose appropriate option. For HDG BACKUP, use ▲ or ▼ on the Omnipad to set time, from 1 to 5 (minutes).
8. Press the [ENT] key.
9. Press the [DISP] key to close the menu.

### 3.6 Confirming Satellite Status

You can check the receiving condition of each antenna unit as follows:

1. Press the [MENU] key to open the menu.
2. Choose SATELLITE and press the [ENT] key.

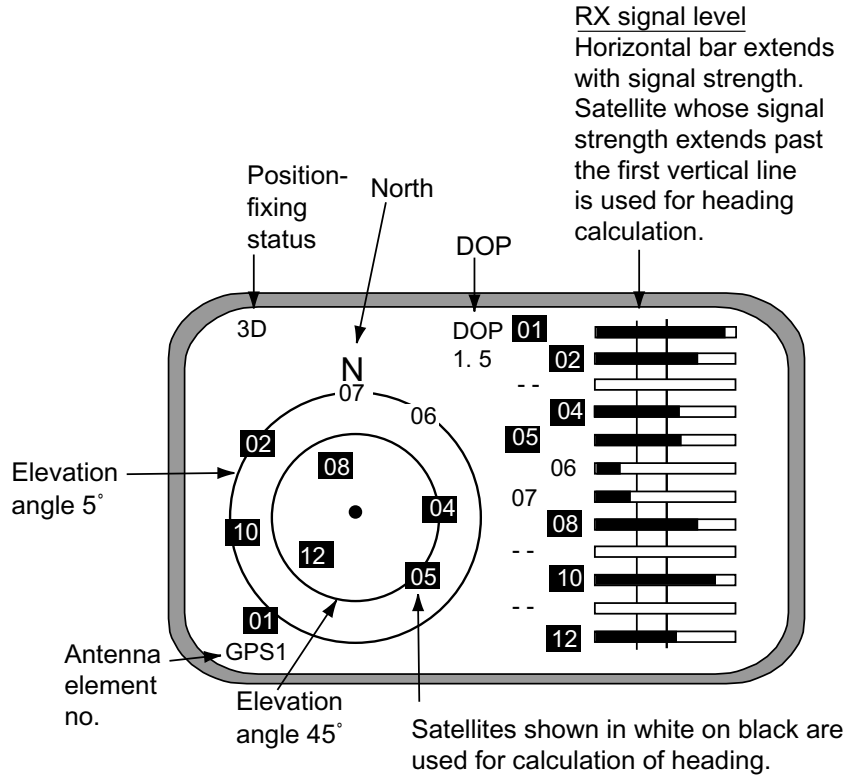

*Satellite status display*

3. Use ◀ or ▶ on the Omnipad to choose antenna element for which to confirm receiving status.
4. Press the [DISP] key to close the menu.

## 3.7 GPS Setup

The GPS SETUP menu smooths position and course, averages speed, applies position offset, and deactivates unhealthy satellites.

### 3.7.1 Displaying the GPS setup menu

1. Press the [MENU] key to open the menu.
2. Choose GPS SETUP and press the [ENT] key.

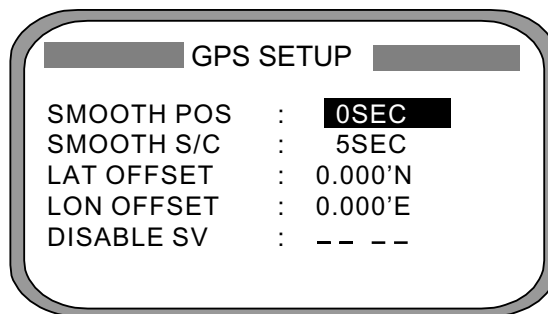

*GPS SETUP menu*

### 3.7.2 GPS SETUP menu description

#### **SMOOTH POS (Smoothing position)**

When the DOP (Dilution of Precision, the index for position-fixing accuracy) or receiving condition is unfavorable, the GPS fix may change randomly, even if the vessel is at anchor. This change can be smoothed by averaging a number of GPS fixes. The setting range is from 0 (no smoothing) to 999 seconds, and the default is 5 s, which is good for a rolling period of 5-8 s. The higher the setting, the more smoothing. However, too high a setting slows updating of position. "0" is the default setting; increase the setting if the GPS fix fluctuates largely.

#### **SMOOTH S/C (Smoothing speed/course)**

Ship's speed and course are directly measured by receiving GPS satellite signals, independent of positions. The data varies with receiving conditions and other factors. You can reduce this random variation by increasing the smoothing. The higher the setting, the more that speed and course are smoothed. If the setting is too high, however, the follow-up to actual values gets slower. The setting range is from 0 (no smoothing) to 999 seconds.

#### **LAT/LON OFFSET (L/L position offset)**

If GPS fixes are erroneous while at anchor, enter a position offset to compensate for position error. Consult a nautical chart to determine latitude and longitude differences between the chart and GPS display. Enter that value as the offset.

#### **DISABLE SV (Disable satellite)**

Every GPS satellite is broadcasting abnormal satellite number(s) in its Almanac, which contains general orbital data about all GPS satellites. Using this

information, the GPS receiver automatically eliminates any malfunctioning satellite from the GPS satellite schedule. However, the Almanac sometimes may not contain this information. If you hear of an inoperative satellite you can disable it manually. Enter satellite number in two digits and press the [ENT] key. To restore a satellite, enter "00".

## 3.8 Output Data

### 3.8.1 Heading

Heading data is output from the HDG OUT port on the processor unit, in IEC 61162-1 format. For further details about input/output data ports see page A-7.

1. Press the [MENU] key to open the menu.
2. Choose I/O SETUP and press the [ENT] key to show the OUTPUT DATA SETUP menu.
3. Press the [ENT] key to show the HDG OUT display.
  - HDT: True heading (required for radar, AIS, ECDIS, etc.)
  - HDM: Magnetic heading
  - VTG: Course over ground and ground speed
  - ZDA: Time and date
  - GGA: Global positioning system (GPS) fix data
  - ROT: Rate-of-turn data
  - VDR: Set and drift
4. Choose item desired and press the [ENT] key.
5. Choose ON or OFF as appropriate and press the [ENT] key.
6. Press the [DISP] key to close the menu.

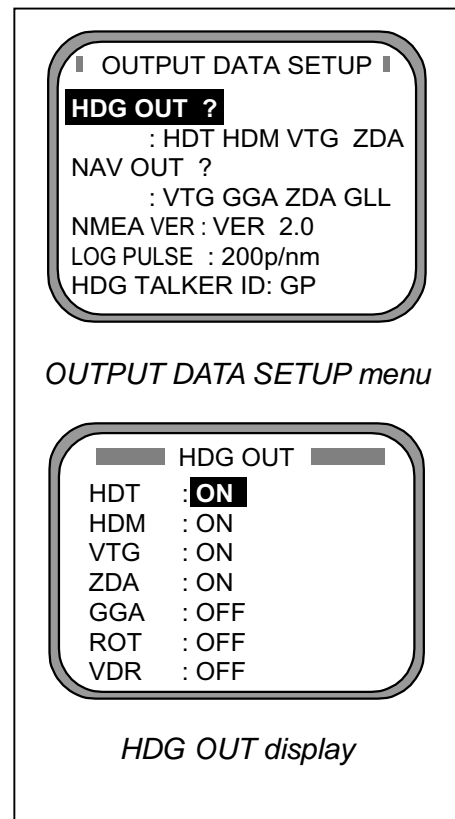

**Note 1:** Some boaters may want magnetic heading when the boat is fitted with only a magnetic compass without correction of deviation and variation. HDM is obtained in this equipment by adding the magnetic variation to HDT automatically.

**Note 2:** VBW and VHW sentences must be input at the HDG IN port to output the VDR sentence.

### 3.8.2 Navigation data

Choose the data to output from the NAV OUT port as follows:

1. Press the [MENU] key.
2. Choose I/O SETUP and press the [ENT] key.
3. Choose "NAV OUT?" and press the [ENT] key.

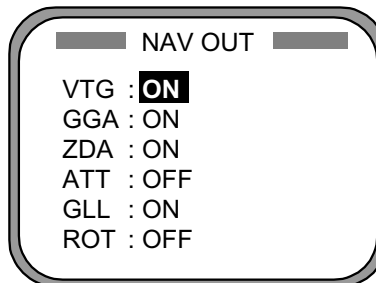

*NAV OUT menu*

VTG: Course over ground and ground speed  
 GGA: Global positioning system (GPS) fix data  
 ZDA: Time and date  
 ATT: True heading, pitching, rolling  
 GLL: Geographic position (latitude and longitude)  
 ROT: Rate-of-turn data

4. Choose item desired and press the [ENT] key.



5. Choose ON or OFF as appropriate and press the [ENT] key.
6. Press the [DISP] key to close the menu.

### 3.8.3 Interface

Normally choose IEC for supplying heading information to AIS and radars. If you are unsure of the version your equipment uses, try all three and choose the one which successfully outputs data.

1. Press the [MENU] key to open the menu.
2. Choose I/O SETUP and press the [ENT] key.
3. Choose NMEA VER and press the [ENT] key.

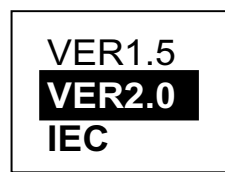

*Format selection window*

4. Choose VER 1.5, VER 2.0 or IEC as appropriate and press the [ENT] key.

### 3.8.4 Log pulse

This equipment provides SOG (speed over ground) in high accuracy. It converts an SOG value to a closure signal and outputs at the rate of 200 or 400 pulses/nm.

1. Press the [MENU] key.
2. Choose I/O SETUP and press the [ENT] key.
3. Choose LOG PULSE and press the [ENT] key.

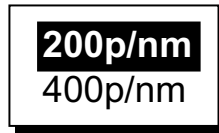

*Log pulse rate selection window*

4. Choose 200 p/nm or 400 p/nm as appropriate and press the [ENT] key.
5. Press the [DISP] key to close the menu.

### 3.8.5 Talker identifier mnemonics

Choose the heading talker ID for the output data sentence HDT and HDM as follows:

1. Press the [MENU] key.
2. Choose I/O SETUP and press the [ENT] key.
3. Choose HDG TALKER ID and press the [ENT] key.

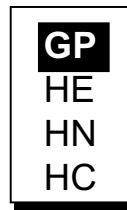

*Heading talker selection window*

4. Choose GP, HE, HN or HC as appropriate and press the [ENT] key. Choose GP normally. If an external gyrocompass is to be used, choose HC.  
GP: GPS Navigator  
HE: North-seeking gyrocompass  
HN: Non-north seeking gyrocompass  
HC: Gyrocompass
5. Press the [DISP] key to close the menu.



## 3.9 System Setup

### 3.9.1 Geodetic data

Your unit is preprogrammed to recognize most of the major chart systems of the world. Although the WGS-84 system (default setting) is the GPS standard, other categories of charts in other datum still exist. Match the GPS datum with the chart system.

1. Press the [MENU] key to open the menu.
2. Choose SYS SETUP and press the [ENT] key.

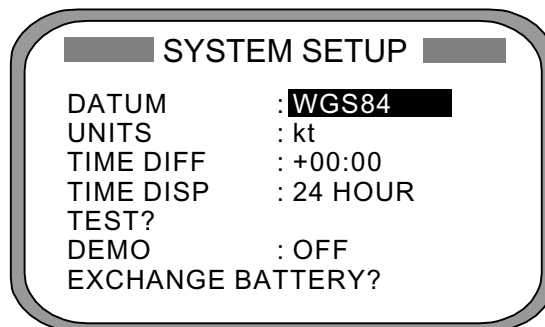

*SYSTEM SETUP menu*

3. Confirm that the cursor is selecting DATUM and press the [ENT] key.
4. Choose WGS84 (GPS standard), WGS72 or OTHER according to the nautical chart you use and press the [ENT] key.
5. If you chose WGS72 or WGS84, press the [DISP] key to finish. For OTHER, go to step 6.
6. Press the [ENT] key.
7. Use the Omnipad to enter chart number, referring to the geodetic chart list on page A-2. Choose location with ◀ or ▶; change value with ▲ or ▼.
8. Press the [ENT] key.
9. Press the [DISP] key to close the menu.

### 3.9.2 Units of measurement

Distance/speed can be displayed in nautical miles/knots, kilometers/kilometers per hour, or miles/miles per hour.

1. Press the [MENU] key to open the menu.
2. Choose SYS SETUP and press the [ENT] key.
3. Choose UNITS.
4. Press the [ENT] key.
5. Choose unit of measurement combination desired; kt, km/h, mi/h.
6. Press the [ENT] key.
7. Press the [DISP] key to close the menu.

### 3.9.3 Using local time

GPS uses UTC time. If you would rather use local time, enter the time difference (range: -13:30 to +13:30) between local time and UTC.

1. Press the [MENU] key to open the menu.
2. Choose SYS SETUP and press the [ENT] key.
3. Choose TIME DIFF and press the [ENT] key.
4. Press ▲ or ▼ to display + or – as appropriate.
5. Enter time difference with the Omnipad. Choose digit with ◀ or ▶; change value with ▲ or ▼.
6. Press the [ENT] key.
7. Press the [DISP] key to close the menu.

### 3.9.4 Time format

Time can be displayed in 12 hour or 24 hour format.

1. Press the [MENU] key to open the menu.
2. Choose SYS SETUP and press the [ENT] key.
3. Choose TIME DISP and press the [ENT] key.
4. Choose 12HOUR or 24HOUR as appropriate and press the [ENT] key.
5. Press the [DISP] key to close the menu.

### 3.9.5 Demonstration mode

The demonstration mode provides simulated operation of the equipment.

1. Press the [MENU] key to open the menu.
2. Choose SYS SETUP and press the [ENT] key.
3. Choose DEMO and press the [ENT] key.
4. Choose ON or OFF as appropriate and press the [ENT] key.
5. Press the [DISP] key to close the menu.

The indication SIM appears at the top of the screen when the demonstration mode is active. When the demonstration mode is first made active, SIMULATION MODE appears when the power is turned on and it is erased when any key is pressed.

## 3.10 DGPS Setup

The internal type DGPS receiver is set at the factory for automatic reception. If you want to set it manually or are using an external beacon receiver, follow the procedure below. Note that DGPS increases position accuracy but it does not affect heading accuracy.

### 3.10.1 Manual DGPS setup

1. Press the [MENU] key to open the menu.
2. Choose DGPS and press the [ENT] key.

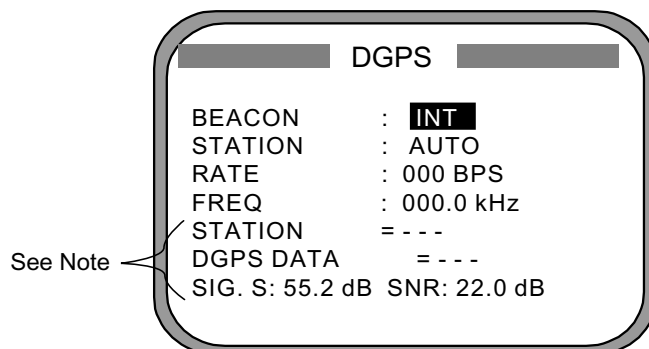

*DGPS menu*

**DGPS Data**

STATION: Shows GOOD or NG.

DGPS DATA: Shows GOOD or NG.

SIG. S = Signal Strength. A figure between 0 and 99 is shown. The higher the figure the stronger the beacon signal.

SNR = Signal to Noise Ratio. A figure between 1 and 22 is shown. When your boat is in the service area of a beacon station, SNR should be 21 or 22. If the figure is below 18 the position will be inaccurate. If this happens, check for radar interference, poor ground and generator noise on own ship.

### 3. OPERATION

3. The cursor is on the BEACON field. Press the [ENT] key.

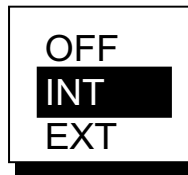

*Beacon receiver selection window*

4. Choose appropriate option and press the [ENT] key.

**INT:** For internal DGPS beacon receiver.

**EXT:** For external DGPS beacon receiver

**OFF:** Disables DGPS function. When OFF is chosen, it takes about one minute to find GPS position.

**Note:** When connecting a FURUNO external DGPS beacon receiver (such as the GR-80) to the SC-60, turn the GR-80's remote function on to set up the beacon receiver with commands from the SC-60. Also set the external DGPS beacon receiver as follows: Byte Format, 8-6; First Bit, LSB; Parity Bit, None; Stop Bit, 1; Bit Rate, 8.

5. Press the [ENT] key.

6. Choose DGPS beacon station selection method: AUTO, MANUAL or LIST.

**AUTO:** Automatically searches for best DGPS beacon station.

**MANUAL:** Manually enter DGPS beacon station specifications in the RATE and FREQ fields, referring to a DGPS beacon station list.

**LIST:** Lists five of the closest DGPS beacon stations, including user-programmed stations.

7. Press the [ENT] key. If you chose AUTO, no further operation is required; press the [DISP] key to close the menu. For MANUAL or LIST follow the appropriate procedure below.

#### **MANUAL**

- a) The cursor is now on the RATE field. Press the [ENT] key.
- b) Choose the transmission rate of the DGPS beacon station to be used, among 50, 100 or 200 bps. Press the [ENT] key.
- c) The cursor is now on the FREQ field. Press the [ENT] key.
- d) Enter the transmission frequency of the DGPS beacon station to be used and press the [ENT] key.

**LIST**

a) The following display appears after pressing the [ENT] key at step 7.

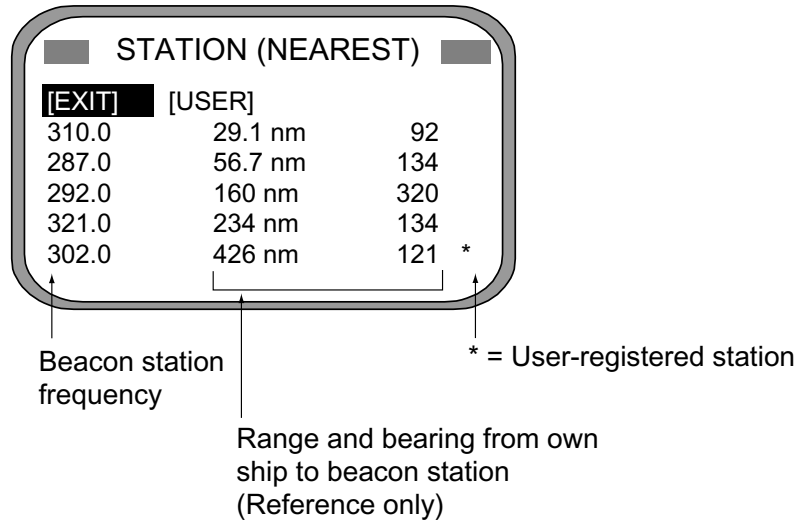

*Beacon station display*

- b) Choose desired station with the Omnipad.
- c) Press the [ENT] key.

8. Press the [DISP] key to close the menu.

**3.10.2 Programming user beacon stations**

The user may program 20 DGPS beacon stations from which to use in selection of DGPS beacon station. Whenever a new station comes into operation, you can add it to the list.

1. Press the [MENU] key to open the menu.
2. Choose DGPS and press the [ENT] key.
3. Choose STATION and press the [ENT] key.
4. Choose LIST and press the [ENT] key.
5. Choose USER and press the [ENT] key to show the STATION (USER) display.

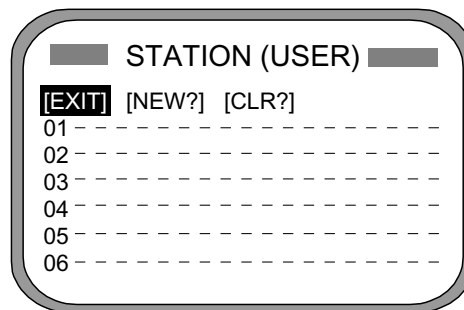

*STATION (USER) display*

6. Choose "NEW?" and press the [ENT] key.

| NEW USER CHANNEL |            |
|------------------|------------|
| FREQ             | : 310.0kHz |
| RATE             | : 200BPS   |
| LAT              | : 37°59'N  |
| LON              | : 133°00'E |
| EXIT? SAVE?      |            |

*NEW USER CHANNEL display*

**Note:** For steps 7-10 use the Omnipad to enter data. Choose location with ◀ or ▶; change value with ▲ or ▼.

7. Press the [ENT] key, enter frequency of the station, and press the [ENT] key.
8. Press the [ENT] key, enter baud rate of the station, and press the [ENT] key.
9. Press the [ENT] key, enter latitude of the station, and press the [ENT] key.
10. Press the [ENT] key, enter longitude of the station, and press the [ENT] key.
11. Choose "SAVE?" and press the [ENT] key.
12. Press the [DISP] key to close the menu.

### 3.10.3 Editing user beacon stations

1. Press the [MENU] key to open the menu.
2. Choose DGPS and press the [ENT] key.
3. Choose STATION and press the [ENT] key.
4. Choose LIST and press the [ENT] key.
5. Choose USER and press the [ENT] key.
6. Choose a station from the list and press the [ENT] key. The display looks something like the one below.

|                   |            |
|-------------------|------------|
| FREQ              | : 310.0kHz |
| RATE              | : 200BPS   |
| LAT               | : 37°59'N  |
| LON               | : 133°00'E |
| EXIT SAVE? ERASE? |            |

*Display for editing user channels*

7. Choose item, press the [ENT] key, edit data, and press the [ENT] key.
8. Choose "SAVE?" and press the [ENT] key.
9. Press the [MENU] key twice to finish.

### 3.10.4 Erasing individual user stations

1. Press the [MENU] key to open the menu.
2. Choose DGPS and press the [ENT] key.
3. Choose STATION and press the [ENT] key.
4. Choose LIST and press the [ENT] key.
5. Choose USER and press the [ENT] key.
6. Choose a channel from the list and press the [ENT] key.
7. Choose "ERASE?".
8. Press the [ENT] key to erase channel chosen.

### 3.10.5 Erasing all user beacon stations

1. Press the [MENU] key to open the menu.
2. Choose DGPS and press the [ENT] key.
3. Choose STATION and press the [ENT] key.
4. Choose LIST and press the [ENT] key.
5. Choose USER and press the [ENT] key.
6. Choose CLR? and press the [ENT] key. You are asked if it is all right to erase all user channels.

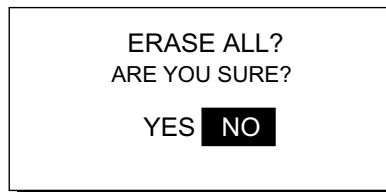

*Prompt for erasure of all user channels*

7. Choose YES and press the [ENT] key to erase all user channels.

## 3.11 OTHERS Menu

The OTHERS menu chooses whether to output last-used heading data, and smooths rate of turn meter reading (rate-of-turn meter required).

1. Press the [MENU] key to display the main menu.

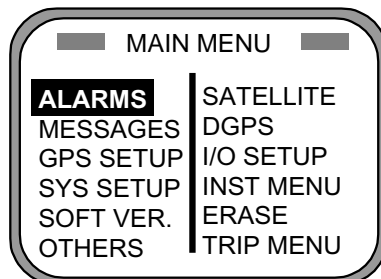

*Main menu*

3. Choose OTHERS and press the [ENT] key.

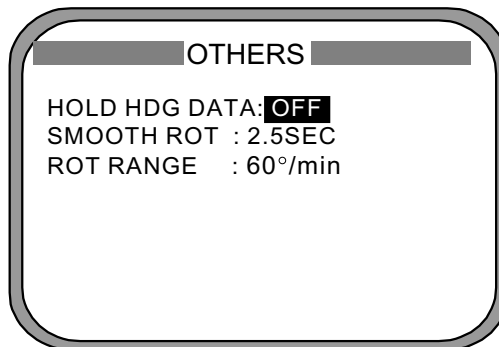

*Others menu*

4. Choose HOLD HDG DATA and press the [ENT] key.
5. Choose ON to use, at power on, last-used heading until current heading is calculated. Last-used heading flashes to inform that it is unreliable.
6. Press the [ENT] key.
7. Choose SMOOTH ROT and press the [ENT] key.
8. Use the Omnipad to enter smoothing time. Choose location with ◀ or ▶; change value with ▲ or ▼.
9. Press the [ENT] key.
10. Choose ROT RANGE and press the [ENT] key.
11. Choose the range of the ROT graph: 30, 60 or 90 and press the [ENT] key.
12. Press the [DISP] key to close the menu.



## 3.12 TRIP Menu

The TRIP menu chooses the indication to show on the Speed display, distance source; resets distance run (see para. 3.13) and smooths the tide drift indication.

1. Press the [MENU] key to display the main menu.
2. Choose TRIP MENU and press the [ENT] key.

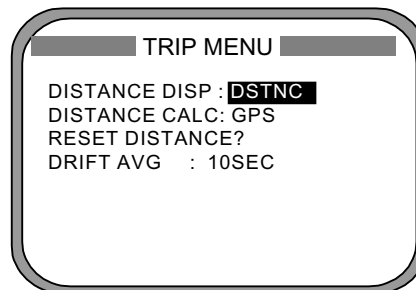

*TRIP menu*

1. Choose DISTANCE DISP and press the [ENT] key.
2. Choose what to display on the Speed display; distance run (DSTNC) or tide direction and speed (DRIFT). Press the [ENT] key.
3. Choose DISTANCE CALC and press the [ENT] key.
4. Choose the source for distance run; GPS, VLW (distance traveled through water) or VBW (Dual ground/water speed). (VLW requires DS-80 type Doppler speed log and VBW requires Current indicator or Doppler speed log.) Press the [ENT] key.
5. Choose DRIFT AVG. and press the [ENT] key.
6. If tide current and speed data is unstable, enter a smoothing figure to stabilize the data. The higher the figure the more smoothed the data. A setting between 0 (no smoothing) and 9999 is available.
7. Press the [ENT] key.
8. Press the [DISP] key to close the menu.

## 3.13 Resetting Distance Run

The distance run may be reset to zero as below when the source of distance run is GPS or VBW.

1. Press the [MENU] key to display the main menu.
2. Choose TRIP MENU and press the [ENT] key.
3. Choose RESET DISTANCE and press the [ENT] key.

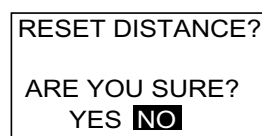

*RESET DISTANCE prompt*

4. Choose YES and press the [ENT] key.
5. Press the [DISP] key to close the menu.

This page is intentionally left blank.

# 4 MAINTENANCE, TROUBLESHOOTING

---

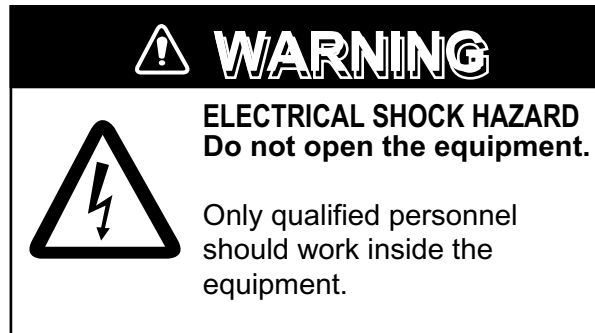

## 4.1 Preventive Maintenance

Regular maintenance is important for good performance. A maintenance program should be established and should include the following points.

- Check connectors and ground terminal on the processor unit and display unit for tightness.
- Check ground terminal for rust. Clean or replace as necessary.
- Check for water leakage in the antenna cable. Replace if necessary.
- Remove dust and dirt from the display unit (including LCD) and processor unit with a dry, soft cloth. Wipe the LCD softly to prevent scratching. Do not use chemical cleaners for cleaning - they can remove paint and markings.

## 4.2 Troubleshooting

This section provides basic troubleshooting procedures which the user may follow to restore normal operation.

### Troubleshooting

| Symptom  | Cause  | Remedy   |
|--|--|--|
| Cannot turn on the power.  | Power connector on the processor unit                        | Firmly connect the power connector.              |
|  | Power supply failure   | Check the power supply.                          |
|  | Blown fuse   | Check the fuse.                                  |
| Heading indication changes randomly when ship is at anchor or does not change when ship moves. | Sensor trouble   | Run the diagnostic test2 to determine cause.     |
| Heading output from SC-60 does not appear on external equipment.                               | Connection between SC-60 and external equipment has loosened | Firmly fasten the connector.                     |
|  | Sensor trouble   | Run the diagnostic test1 to determine the cause. |

If large heading error occurs or heading indication is frequently interrupted, contact your dealer for advice.

## 4.3 Diagnostics

### Diagnostic test1

The diagnostic test checks the equipment for proper operation.

**Note:** Heading is not output during the diagnostic test, and this is communicated with an appropriate message. After completing the diagnostic test, turn the power off and on to update heading data.

1. Press the [MENU] key to open the menu.
2. Choose SYS SETUP and press the [ENT] key.
3. Choose TEST? and press the [ENT] key.

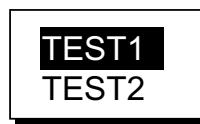

*Test menu options*

4. Confirm that TEST1 is selected and press the [ENT] key.

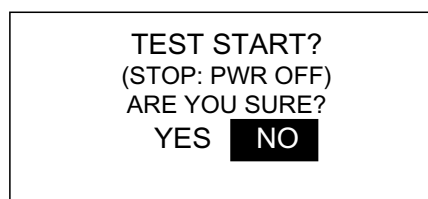

*Test start prompt*

5. Press ◀ to choose YES and press the [ENT] key. The test proceeds in the sequence shown below.

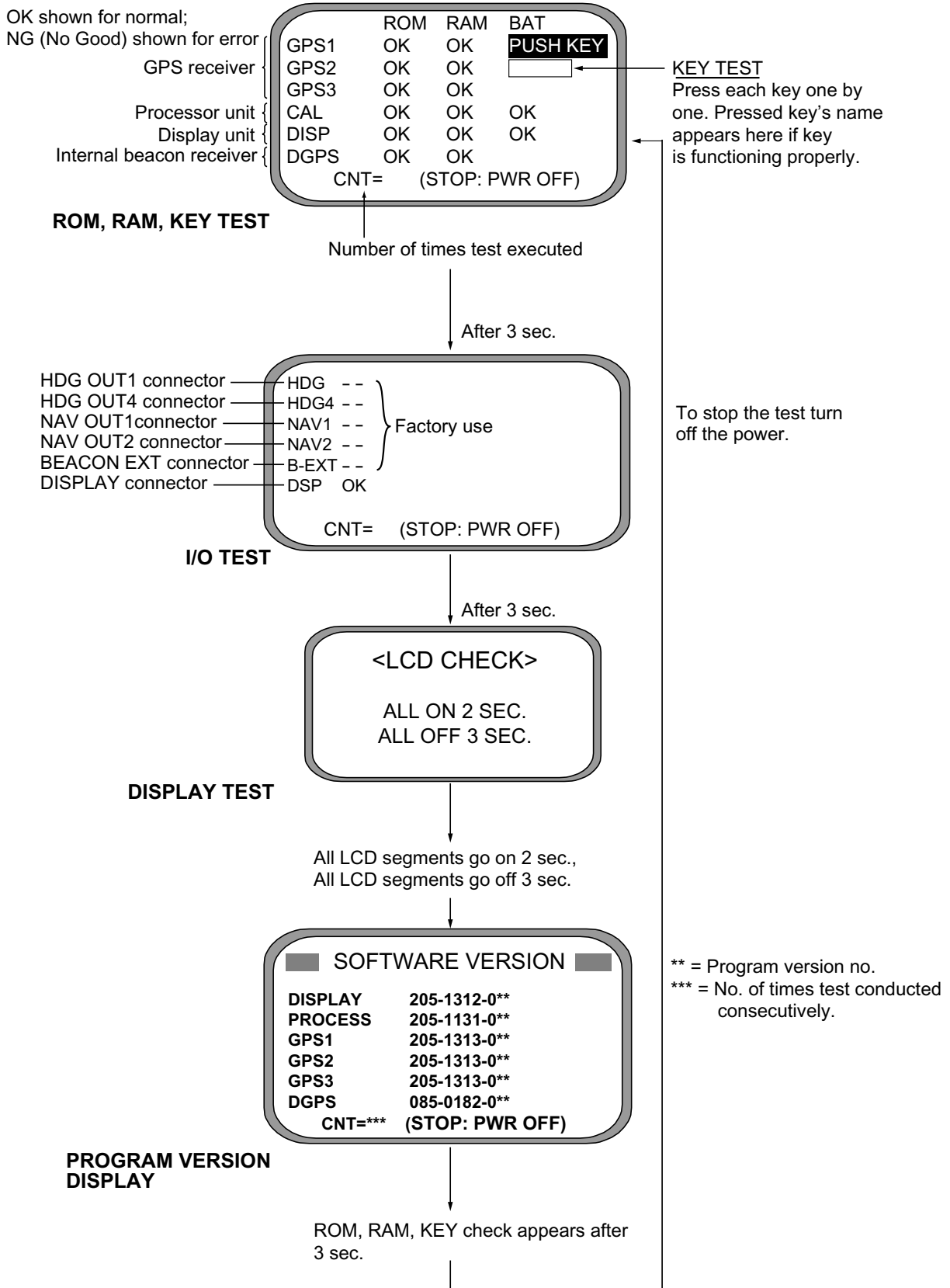

*Diagnostic test sequence*

6. Turn off the processor unit to quit the diagnostic test1.

**Diagnostic test2**

If the heading indication changes randomly when ship is at anchor or does not change when the ship moves, run the test2 following the procedure below, with the ship at anchor and satellite signal received.

**Note:** Heading is not output during the diagnostic test, and this is communicated with an appropriate message. After completing the diagnostic test, turn the power off and on to update heading data.

1. Press the [MENU] key to open the menu.
2. Choose SYS SETUP and press the [ENT] key.
3. Choose TEST? and press the [ENT] key.

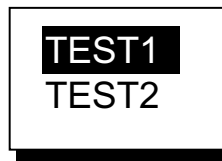

*Test menu options*

4. Choose TEST2 and press the [ENT] key.

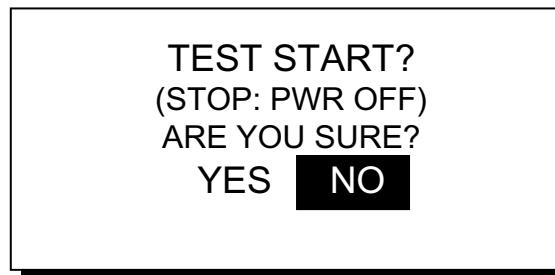

*Test start prompt*

5. Press ◀ to choose YES and press the [ENT] key.
6. Press the [ENT] key twice. Rate and angle values are 0.0°. If the values increase or decrease markedly (with ship at anchor), suspect rate sensor trouble. Contact your dealer to request service.

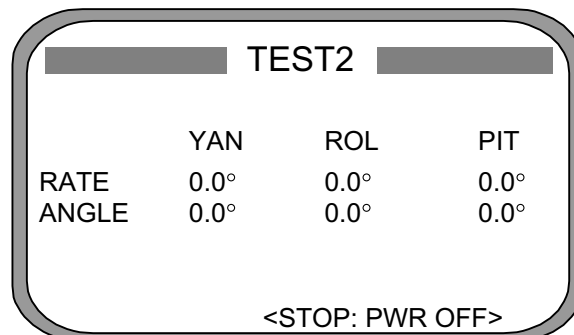

*TEST2 display*

7. Turn off the processor unit to quit the diagnostic test2.

## 4.4 Program Number

You may display the program number as follows:

1. Press the [MENU] key to open the menu.
2. Choose SOFT VER. and press the [ENT] key.

| SOFTWARE VERSION |              |
|------------------|--------------|
| DISPLAY          | 205-1312-0** |
| PROCESS          | 205-1311-0** |
| GPS1             | 205-1313-0** |
| GPS2             | 205-1313-0** |
| GPS3             | 205-1313-0** |
| DGPS*            | 085-0182-0** |

\* = Blank if no DGPS receiver is connected.

\*\* = Program version no.

*Program version no. display*

3. Press the [DISP] key to close the program version no. display.

## 4.5 Clearing Data

You may clear GPS data and system data all at once or individually as follows:

1. Press the [MENU] key to open the menu.
2. Choose ERASE and press the [ENT] key.
3. Choose GPS DATA, SYSTEM DATA or ALL BACKUP DATA (clears GPS and SYSTEM data) as appropriate. One of the following displays appears depending on your selection.

|  |
|--|
| ERASE GPS DATA?<br><br>ARE YOU SURE?<br>YES <input type="checkbox"/> NO <input type="checkbox"/> |
|--|

|  |
|--|
| ERASE ALL BACKUP<br>DATA? (DEFAULT)<br><br>ARE YOU SURE?<br>YES <input type="checkbox"/> NO <input type="checkbox"/> |
|--|

|  |
|--|
| ERASE SYSTEM<br>DATA? (DEFAULT)<br><br>ARE YOU SURE?<br>YES <input type="checkbox"/> NO <input type="checkbox"/> |
|--|

*Prompts for erasure of data*

4. Press ◀ to choose YES and press the [ENT] key to erase. After data is erased the message "Completed erasing. Turn off the unit." Is displayed.

**Note:** MOUNTING, DIRECTION and LANGUAGE in the INST menu, HDG RESTORATION and HDG BACKUP in the ALARMS menu, STATION in the DGPS menu and OFFSET in the HEADING SETUP menu are not cleared.

5. Turn off and on the power.

## 4.6 Replacement of Battery

The display unit and processor unit have a battery which stores data when the power is turned off. When the battery voltage is low the message "BATTERY!" appears on the display. Open the message display, by pressing the [MENU] key and choosing "MESSAGES", to find out which battery's voltage is low. Have a qualified technician replace the battery, following the procedure below. The life of the batteries is 3-5 years.

| Battery Location | Type         | Code No.    |
|------------------|--------------|-------------|
| Display Unit     | TZ6580553A   | 000-139-951 |
| Processor Unit   | CR2450-F2ST2 | 000-133-495 |

1. Press the [MENU] key to open the menu.
2. Choose SYS SETUP and press the [ENT] key.
3. Choose EXCHANGE BATTERY? And press the [ENT] key.



*Battery exchange options*

4. Choose DISPLAY UNIT or PROCESSOR UNIT as appropriate and press the [ENT] key.

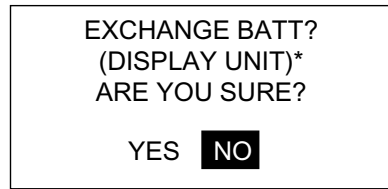

\* Or processor unit

*Prompt for exchanging battery*

5. Press ◀ to choose YES and press the [ENT] key. The following message appears.

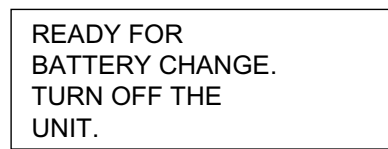

*Prompt for turning off the power*

6. At this time the contents of the RAM are temporarily moved to the flash memory. Turn off the power.
7. Have a qualified technician replace the battery.



## 4.7 Replacement of Fuse

The 3 A fuse on the POWER Board inside the processor unit protects the equipment from overcurrent and reverse polarity of the power supply. If the fuse blows, have a qualified technician check the set and replace the fuse.



## 4.8 Error Messages

The alarm sounds for equipment error and is accompanied by a flashing exclamation mark (⚠). Press any key to silence the alarm. The exclamation mark remains on the screen until the cause for error is eliminated. Find the cause for the alarm(s) as follows:

1. Press the [MENU] key to open the menu.
2. Choose MESSAGES and press the [ENT] key.

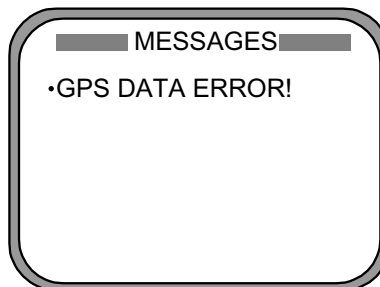

*Message display*

3. Press the [DISP] key to close the menu.

### Error messages

| Error Message         | Meaning   | Remedy  |
|-----------------------|---|---|
| ABORTING!             | GPS heading error continues for one minute. For example, satellite cannot be acquired because of unfavorable environment. | Check for obstruction.                            |
| ABORTING CALC!        | GPS signal interrupted for one minute   | Press any key to try to restore normal operation. |
| BACKUP ERROR!(DISP)   | Corrupted backup data found in display unit at power on.  | Default settings are automatically restored.      |
| BACKUP ERROR!(PRCSSR) | Corrupted backup data found at processor unit at power on.  | Default settings are automatically restored.      |

*(Continued on next page)*

#### 4. MAINTENANCE, TROUBLESHOOTING

*Error messages (con't from previous page)*

| <b>Error Message</b>  | <b>Meaning</b>  | <b>Remedy</b>  |
|-----------------------|---|--|
| BATTTERY!             | Voltage of battery in display unit or processor unit may be low.  | Open the Message Display to see which battery's voltage is low. Have a qualified technician replace the battery. |
| BATTERY ALM!(DISP)    | Voltage of battery in display unit is low.  | Have battery replaced at earliest convenience.   |
| BATTERY ALM!(PRC SSR) | Voltage of battery in processor unit is low.  | Have battery replaced at earliest convenience.   |
| DATA ERR!             | GPS data (from the GPS receiver in the processor unit) is lost for one minute. Heading output is stopped and the heading indication shows " - - -". | Check navigator.   |
| DGPS ERROR!           | DGPS data (from the DGPS receiver in the processor unit) is lost for one minute.  | Ship may not be within DPGS service area.  |
| GPS DATA ERROR!       | GPS data (from the GPS receiver in the processor unit) is lost for one minute. Heading output is stopped and the heading indication shows " - - -". | Conduct diagnostic test and check if NG appears for results for GPS receivers GPS1, GPS2 and GPS3.               |
| GPS NO FIX!           | No GPS data.  | Check antenna cable.   |
| HDG ERROR!            | Heading error   | Request service.   |
| NO HEADING OUTPUT!    | GPS heading error continues for five minutes. In this case heading output is stopped and the heading indication shows " - - -".                     | Press any key to try to restore normal operation.  |
| RAM ERROR!            | RAM problem   | Request service.   |
| RATE ERROR!           | Data output stopped.  | Request service.   |
| ROM ERROR!            | ROM problem   | Request service.   |

# APPENDIX A

## Menu Tree

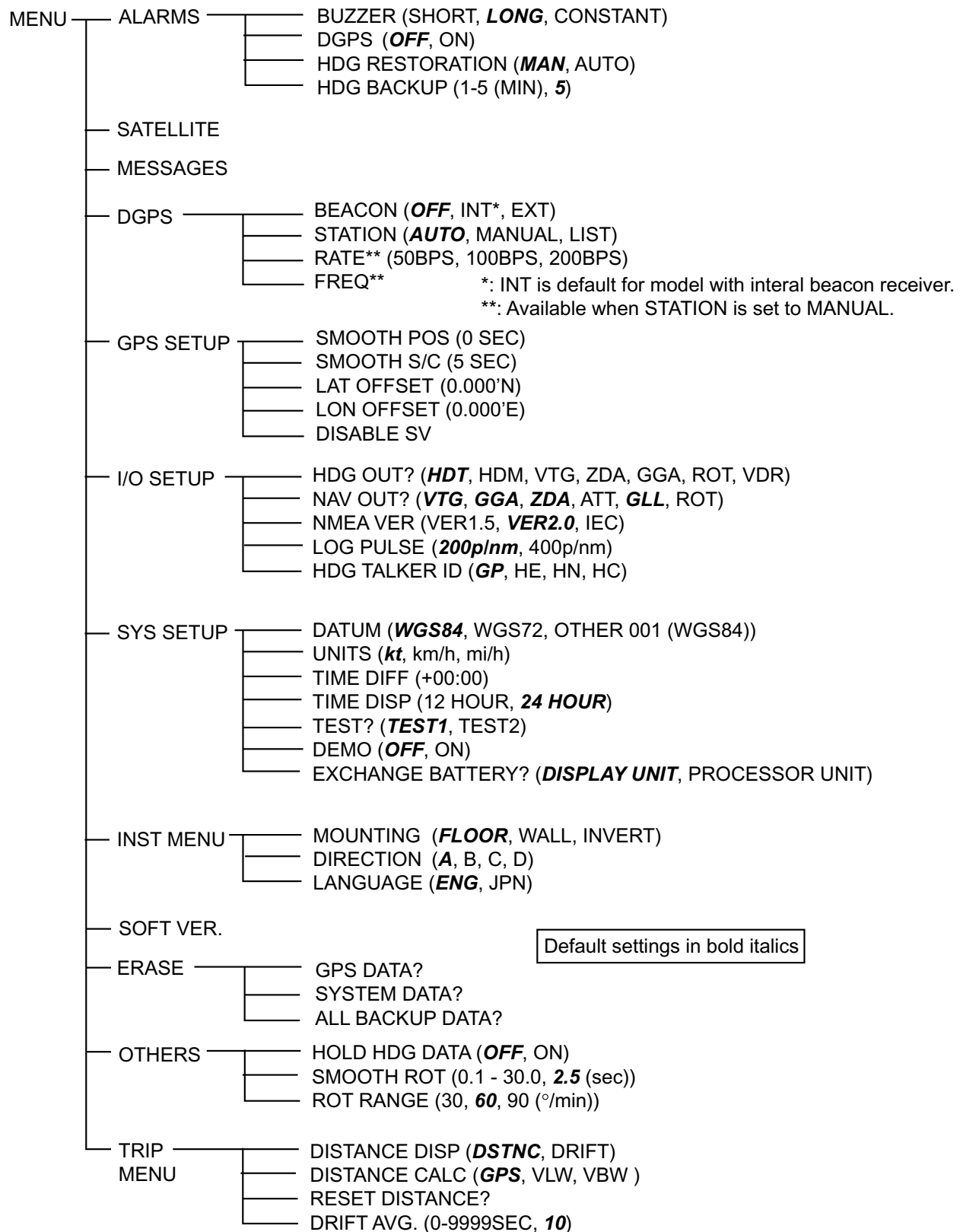

Default settings in bold italics

# Geodetic Chart Codes

|      |                          |  |      |   |  |
|------|--------------------------|--|------|---|--|
| 001: | WGS84                    |  | 089: |   | : Eastern United States                            |
| 002: | WGS72                    |  | 090: |   | : Alaska   |
| 003: | TOKYO                    | : Mean Value (Japan, Korea & Okinawa)            | 091: | :   | : Bahamas (excl. San Salvador Is.)                 |
| 004: | NORTH AMERICAN 1927      | : Mean Value (CONUS)                             | 092: |   | : Bahamas, San Salvador Is.                        |
| 005: | EUROPEAN 1950            | : Mean Value                                     | 093: |   | : Canada (incl. Newfoundland Is.)                  |
| 006: | AUSTRALIAN GEODETIC 1984 | : Australia & Tasmania                           | 094: |   | : Alberta & British Columbia                       |
| 007: | ADINDAN                  | : Mean Value (Ethiopia & Sudan)                  | 095: |   | : East Canada                                      |
| 008: |                          | : Ethiopia                                       | 096: |   | : Manitoba & Ontario                               |
| 009: |                          | : Mali   | 097: |   | : Northwest Territories & Saskatchewan             |
| 010: |                          | : Senegal  | 098: |   | : Yukon  |
| 011: |                          | : Sudan  | 099: |   | : Canal Zone                                       |
| 012: | AFG                      | : Somalia  | 100: |   | : Caribbean  |
| 013: | AIN EL ABD 1970          | : Bahrain Is.                                    | 101: |   | : Central America                                  |
| 014: | ANNA 1 ASTRO 1965        | : Cocos Is.                                      | 102: |   | : Cuba   |
| 015: | ARC 1950                 | : Mean Value                                     | 103: |   | : Greenland  |
| 016: |                          | : Botswana                                       | 104: |   | : Mexico   |
| 017: |                          | : Lesotho  | 105: | NORTH AMERICAN 1983                                     | : Alaska   |
| 018: |                          | : Malawi   | 106: |   | : Canada   |
| 019: |                          | : Swaziland                                      | 107: |   | : CONUS  |
| 020: |                          | : Zaire  | 108: |   | : Mexico, Central America                          |
| 021: |                          | : Zambia   | 109: | OBSERVATORIO 1966                                       | : Corvo & Flores Islands (Azores)                  |
| 022: |                          | : Zimbabwe                                       | 110: | OLD EGYPTIAN 1930                                       | : Egypt  |
| 023: | ARC 1960                 | : Mean Value (Kenya & Tanzania)                  | 111: | OLD HAWAIIAN  | : Mean Value                                       |
| 024: |                          | : Kenya  | 112: |   | : Hawaii   |
| 025: |                          | : Tanzania                                       | 113: |   | : Kauai  |
| 026: | ASCENSION IS. 1958       | : Ascension Is.                                  | 114: |   | : Maui   |
| 027: | ASTRO BEACON OEO         | : Iwo Jima Is.                                   | 115: |   | : Oahu   |
| 028: | ASTRO B4 SOR. ATOLL      | : Tern Is.                                       | 116: | OMAN  | : Oman   |
| 029: | ASTRO POS 71/4           | : St. Helena Is.                                 | 117: | ORDNANCE SURVEY OF GREAT BRITAIN 1936: Mean Value       |  |
| 030: | ASTRONOMIC STATION 1952  | : Marcus Is.                                     | 118: |   | : England  |
| 031: | AUSTRALIAN GEODETIC 1966 | : Australia & Tasmania                           | 119: |   | : England, Isle of Man & Wales                     |
| 032: | BELLEVUE (IGN)           | : Efate & Erromango Islands                      | 120: |   | : Scotland, & Shetland Islands                     |
| 033: | BERMUDA 1957             | : Bermuda Islands                                | 121: |   | : Wales  |
| 034: | BOGOTA OBSERVATORY       | : Columbia                                       | 122: | PICO DE LAS NIVIES                                      | : Canary Islands                                   |
| 035: | GAUPO INCHAUSPE          | : Argentina                                      | 123: | PITCAIRN ASTRO 1967                                     | : Pitcairn Is.                                     |
| 036: | CANTON IS. 1966          | : Phoenix Islands                                | 124: | PROVISIONS SOUTH CHILEAN 1963: South Chile (near 53û S) |  |
| 037: | CAPE                     | : South Africa                                   | 125: | PROVISIONAL SOUTH AMERICAN 1956: Mean Value             |  |
| 038: | CAPE CANAVERAL           | : Mean Value (Florida & Bahama Islands)          | 126: |   | : Bolivia  |
| 039: | CARTHAGE                 | : Tunisia  | 127: |   | : Chile-Northern Chile (near 19ûS)                 |
| 040: | CHATHAM 1971             | : Chatham Is. (New Zealand)                      | 128: |   | : Chile-Southern Chile (near 43ûS)                 |
| 041: | CHUA ASTRO               | : Paraguay                                       | 129: |   | : Columbia   |
| 042: | CORREGO ALEGRE           | : Brazil   | 130: |   | : Ecuador  |
| 043: | DJAKARTA (BATAVIA)       | : Sumatra Is. (Indonesia)                        | 131: |   | : Guyana   |
| 044: | DOS 1968                 | : Gizo Is. (New Georgia Is.)                     | 132: |   | : Peru   |
| 045: | EASTER IS. 1967          | : Easter Is.                                     | 133: |   | : Venezuela  |
| 046: | EUROPEAN 1950 (Cont'd)   | : Western Europe                                 | 134: | PUERTO RICO   | : Puerto Rico & Virgin Islands                     |
| 047: |                          | : Cyprus   | 135: | QATAR NATIONAL  | : Qatar  |
| 048: |                          | : Egypt  | 136: | QORNOQ  | : South Greenland                                  |
| 049: |                          | : England, Scotland, Channel & Shetland Islands  | 137: | ROME 1940   | : Sardinia Islands                                 |
| 050: |                          | : England, Ireland, Scotland, & Shetland Islands | 138: | SANTA BRAZ  | : Sao Maguel, Santa Maria Islands (Azores)         |
| 051: |                          | : Greece   | 139: | SANTO (DOS)   | : Espirito Santo Is.                               |
| 052: |                          | : Iran   | 140: | SAPPER HILL 1943  | : East Falkland Is.                                |
| 053: |                          | : Italy, Sardinia                                | 141: | SOUTH AMERICAN 1969                                     | : Mean Value                                       |
| 054: |                          | : Italy, Sicily                                  | 142: |   | : Argentina  |
| 055: |                          | : Norway & Finland                               | 143: |   | : Bolivia  |
| 056: |                          | : Portugal & Spain                               | 144: |   | : Brazil   |
| 057: | EUROPEAN 1979            | : Mean Value                                     | 145: |   | : Chile  |
| 058: | GANDAJIKA BASE           | : Republic of Maldives                           | 146: |   | : Columbia   |
| 059: | GEODETIC DATUM 1949      | : New Zealand                                    | 147: |   | : Ecuador  |
| 060: | GUAM 1963                | : Guam Is.                                       | 148: |   | : Guyana   |
| 061: | GUX 1 ASTRO              | : Guadalcanal Is.                                | 149: |   | : Paraguay   |
| 062: | HJORSEY 1955             | : Iceland  | 150: |   | : Peru   |
| 063: | HONG KONG 1363           | : Hong Kong                                      | 151: |   | : Trinidad & Tobago                                |
| 064: | INDIAN                   | : Thailand & Vietnam                             | 152: |   | : Venezuela  |
| 065: |                          | : Bangladesh, India & Nepal                      | 153: | SOUTH ASIA  | : Singapore  |
| 066: | IRELAND 1965             | : Ireland  | 154: | SOUTHEAST BASE  | : Porto Santo & Madeira Islands                    |
| 067: | ISTS 073 ASTRO 1969      | : Diego Garcia                                   | 155: | SOUTHWEST BASE  | : Faial, Graciosa, Pico, Sao Jorge, & Terceira Is. |
| 068: | JOHNSTON IS. 1961        | : Johnston Is.                                   | 156: | TIMBALAI 1948   | : Brunei & East Malaysia (Sarawak & Sadah)         |
| 069: | KANDAWALA                | : Sri Lanka                                      | 157: | TOKYO   | : Japan  |
| 070: | KERGUELEN IS.            | : Kerguelen Is.                                  | 158: |   | : Korea  |
| 071: | KERTAU 1948              | : West Malaysia & Singapore                      | 159: |   | : Okinawa  |
| 072: | LA REUNION               | : Mascarene Is.                                  | 160: | TRISTAN ASTRO 1968                                      | : Tristan da Cunha                                 |
| 073: | L. C. 5 ASTRO            | : Cayman Brac Is.                                | 161: | VITI LEVU 1916  | : Viti Levu Is. (Fiji Islands)                     |
| 074: | LIBERIA 1964             | : Liberia  | 162: | WAKE-ENIWETOK 1960                                      | : Marshall Islands                                 |
| 075: | LUZON                    | : Philippines (excl. Mindanao Is.)               | 163: | ZANDERIJ  | : Surinam  |
| 076: |                          | : Mindanao Is.                                   | 164: | BUKIT RIMPAH  | : Bangka & Belitung Islands (Indonesia)            |
| 077: | MAHE 1971                | : Mahe Is.                                       | 165: | CAMP AREA ASTRO   | : Camp Mcmurdo Area, Antarctica                    |
| 078: | MARCO ASTRO              | : Salvage Islands                                | 166: | G. SEGARA   | : Kalimantan Is. (Indonesia)                       |
| 079: | MASSAWA                  | : Eritrea (Ethiopia)                             | 167: | HERAT NORTH   | : Afghanistan                                      |
| 080: | MERCHICH                 | : Morocco  | 168: | HU-TZU-SHAN   | : Taiwan   |
| 081: | MIDWAY ASTRO 1961        | : Midway Is.                                     | 169: | TANANARIVE OBSERVATORY 1925                             | : Madagascar                                       |
| 082: | MINNA                    | : Nigeria  | 170: | YACARE  | : Uruguay  |
| 083: | NAHRWAN                  | : Masirah Is. (Oman)                             | 171: | RT-90   | : Sweden   |
| 084: |                          | : United Arab Emirates                           | 172: | Pulkovo 1942  | : Russia   |
| 085: |                          | : Saudi Arabia                                   | 173: | FINNISH KKJ   | : Finland  |
| 086: | NAMIBIA                  | : Namibia  |      |   |  |
| 087: | MAPARIMA, BWI            | : Trinidad & Tobago                              |      |   |  |
| 088: | NORTH AMERICAN 1927      | : Western United States                          |      |   |  |

## Digital Interface

### Output sentences of channel 1 (HDG OUT)

HDT, HDM, ROT, VTG, ZDA, GGA (Talker: GP)

### Output sentences of channel 2 (NAV OUT)

ROT, Gpatt, VTG, ZDA, GGA, GLL

### Transmission interval

HDG OUT HDT, HDM, ROT: 100 ms (two of three are selected.)  
VTG, ZDA, GGA: 1 s

NAV OUT: Gpatt, ROT: 100 ms (two of three are selected.)  
200 ms (other cases)  
VTG, ZDA, GGA, GLL: 1 s

### Load requirements as listener

Isolation: Optocoupler  
Input Impedance: 220 ohms (due to common use of output port, AD-10 and NMEA)  
Max. Voltage:  $\pm 15$  V  
Threshold: 4 mA (In case of connection of FURUNO device talker)

### Data transmission

Data is transmitted in serial asynchronous form in accordance with the standard referenced in 2.1 of IEC 61162-1. The first bit is a start bit and is followed by data bits, least-significant-bit as illustrated below.

The following parameters are used:

Baud rate: 4800  
data bits: 8 (D7 = 0), parity none  
stop bits: 1

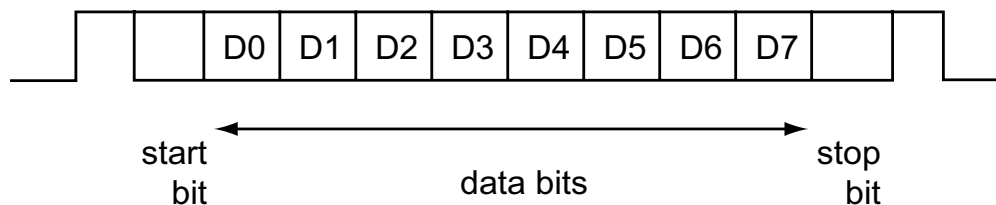

## Schematic diagrams

### HDG IN port (listener)

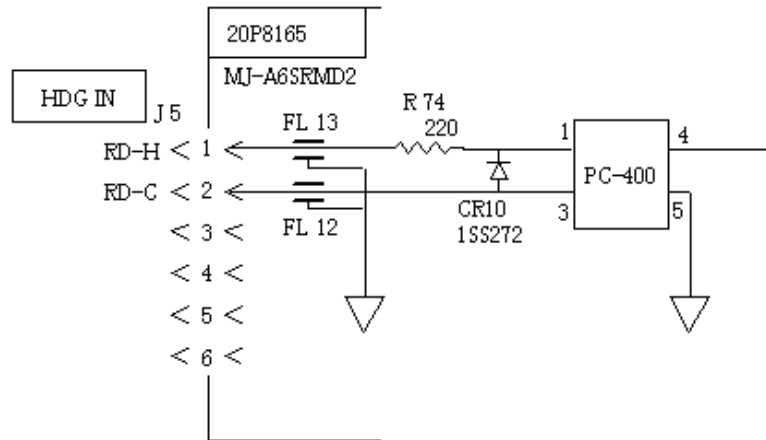

### Load requirements

Isolation: Optocoupler  
 Input Impedance: 220 ohm  
 Max. voltage:  $\pm 15V$

### HDG OUT1 port

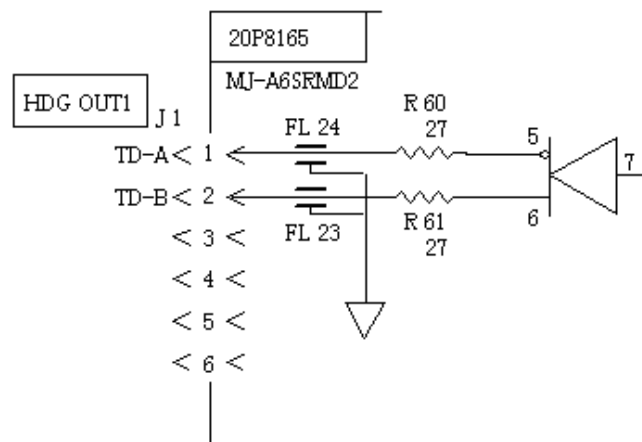

### Output drive capability

Max. 10 mA



## Data sentences

### PFECatt- True heading, pitching, rolling

\$PFEC,GPatt,xxx.x,+xx.x,-xx.x<CR><LF> (Ver. 1.5)

\$PFEC,GPatt,xxx.x,+xx.x,-xx.x\*hh<CR><LF> (Ver. 2.0)

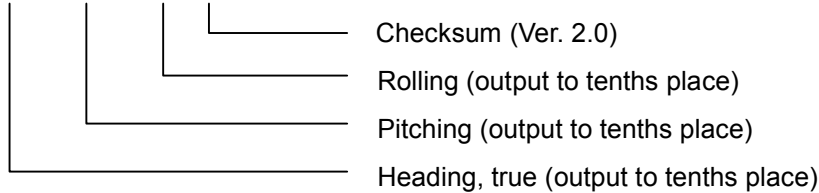

### GGA - Global positioning system (GPS) fix data

Time, position and fix related data for a GPS receiver.

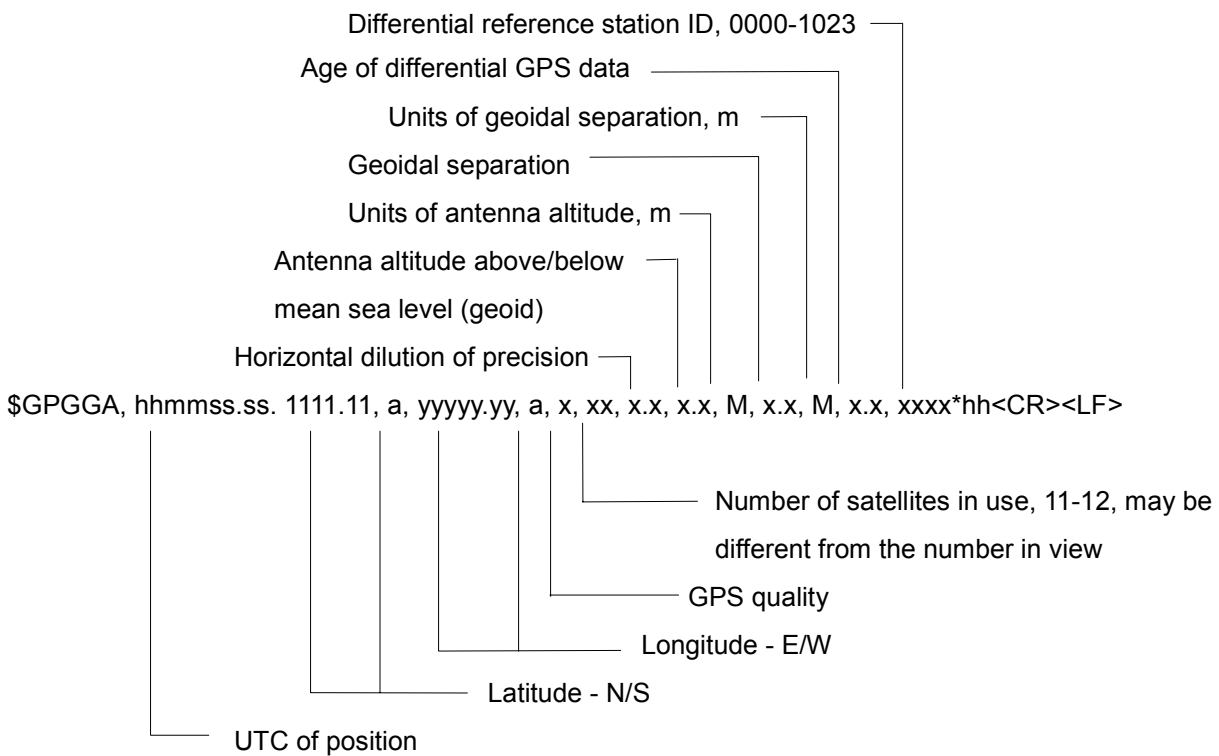

\$GPGGA, hhhmss.ss, 1111.11, a, yyyy.yy, a, x, xx, x.x, x.x, M, x.x, M, x.x, xxxx\*hh<CR><LF>

### GLL - Geographic position - latitude/longitude

Latitude and longitude of present vessel position, time of position fix and status.

\$--GPGLL, 1111.11, a, yyyy.yy, a, hhhmss.ss, A, p\*hh<CR><LF>

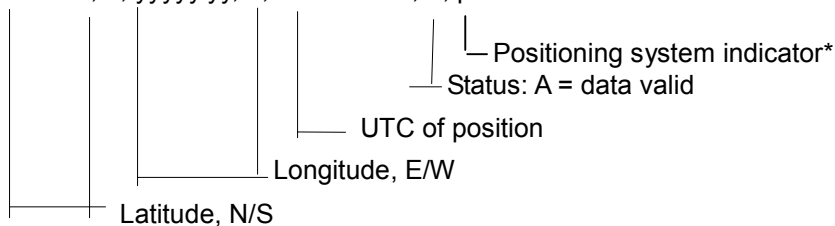

\*A = Autonomous, D = Differential, E = estimated (dead reckoning), M = Manual input, S = Simulator, N = Data not valid. The Mode indicator field supplements the Status field. The Status field shall be set to V=invalid for all values of Operating Mode except for A=Autonomous and D=Differential. The positioning system Mode indicator and Status field shall not be null fields.



### HDM- Heading – magnetic

This sentence is not used in the current version of NMEA and IEC 61162. Some boaters may want the GPS compass to indicate the magnetic heading when the boat is only fitted with a magnetic compass. HDG is calculated by adding a geomagnetic variation to HDT.

\$--HDM, x.x, M \*hh<CR><LF>

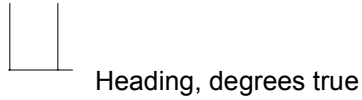

### HDT - Heading - true

True heading in degrees obtained by processing RF cycle in the GPS carrier frequency.

\$--HDT, x.x, T\*hh<CR><LF>

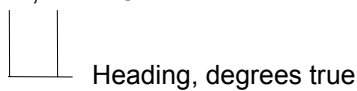

### ROT – Rate of turn

ROT derived from a changing rate of GPS compass heading.

\$--ROT, x.x, A\*hh<CR><LF>

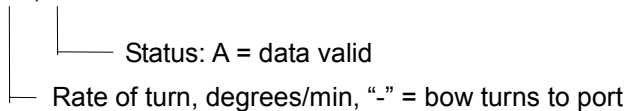

### VBW - Dual ground/water speed

\$--VBW,x.x,x.x,A,x.x,x.x,A,x.x,x.x,A,x.x,A\*hh<CR><LF>

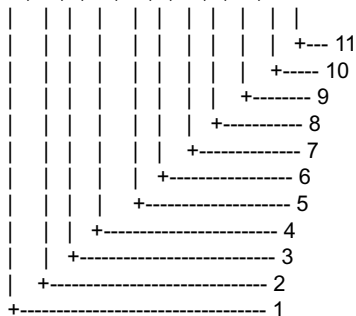

1. Longitudinal water speed, knots
2. Transverse water speed, knots
3. Status: water speed, A=data valid V=data invalid
4. Longitudinal ground speed, knots
5. Transverse ground speed, knots
6. Status: ground speed, A=data valid V=data invalid
7. Stern transverse water speed, knots
8. Status: stern water speed, A=data valid V=data invalid
9. Stern transverse ground speed, knots
10. Status: stern ground speed, A=data valid V=data invalid
11. Checksum



### VTG - Course over ground and ground speed

COG and SOG obtained by processing the GPS signals.

\$GPVTG, x.x, T, x.x, M, x.x, N, x.x, K, p\*hh<CR><LF>

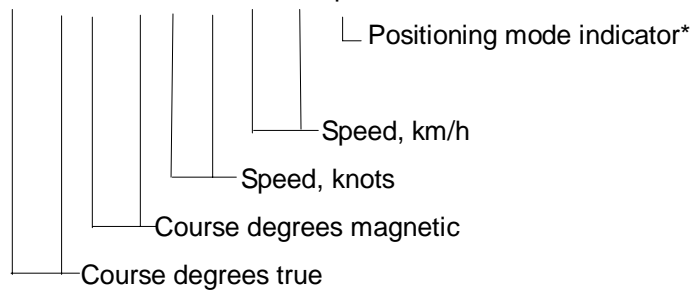

\*A = Autonomous, D = Differential, E = estimated(dead reckoning), M = Manual input, S = Simulator, N = Data not valid. The Mode indicator field supplements the Status field. The Status field shall be set to V=invalid for all values of Operating Mode except for A=Autonomous and D=Differential. The positioning system Mode indicator and Status field shall not be null fields.

### ZDA - Time and date

UTC, day, month, year and local time zone.

\$GPZDA. hhmmss.ss, xx, xx, xxxx, xx, xx\*hh<CR><LF>

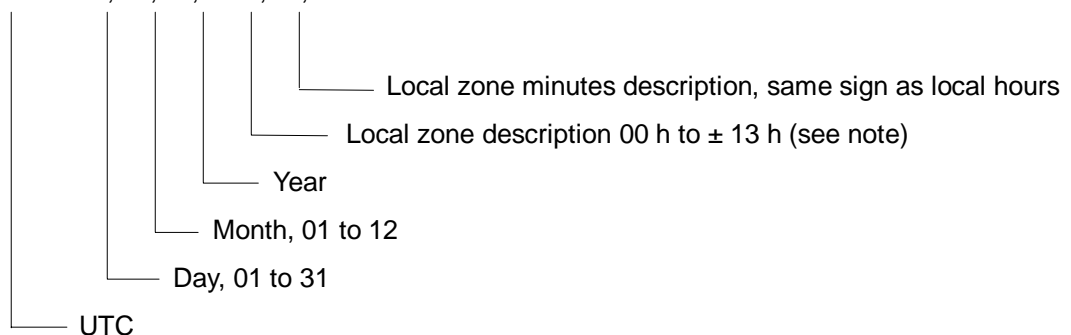

NOTE - Zone description if the number of whole hours added to local time to obtain GMT. Zone description is negative for east longitudes.

## Input/Output Ports

| Port Label              | Connector Type | I/O | Signal                                     | Remarks   |
|-------------------------|----------------|-----|--|---|
| HDG OUT1                | MJ6            | O   | Heading                                    | 1) IEC 61162 (NMEA 0183) or AD-10 format (hardware)   |
| HDG OUT2                | MJ6            | O   | Heading                                    | 2) IEC 61162 (NMEA 0183) Ver.1.5 2.0 (software)   |
| HDG OUT3                | MJ6            | O   | Heading                                    | 3) Talker: GP<br>4) Speed: 4800 bps<br>5) IEC 61162 sentences: HDM, HDT, ROT, VTG, ZDA, GGA (VTG, ZDA, and GGA are factory-set to OFF.)<br>6) IEC 61162 (NMEA 0183) sentence output interval: HDM, HDT, ROT: 0.1 sec and others: 1 sec<br>7) AD-10 output interval: 25 ms<br>8) Signal level: IEC 61162<br><br>Heading data selected in the HDG SETUP menu is output.   |
| HDG OUT4                | DSUB9          | O   | Heading                                    | 1) IEC 61162 (NMEA 0183) only<br>2) Signal level: RS-232C<br>3) Used for program upgrade  |
| NAV OUT1<br>(IEC 61162) | MJ6            | O   | Speed,<br>course,<br>position,<br>and time | 1) IEC 61162 (NMEA 0183) Ver.1.5 or 2.0 (software)  |
| NAV OUT2<br>(RS-232C)   | DSUB9          |     |  | 2) Talker: GP<br>3) Speed: 4800 bps<br>4) IEC 61162 (NMEA 0183) sentences: VTG, GGA, GLL, ROT, ZDA (on/off by menu)<br>5) IEC 61162 (NMEA 0183) sentence output interval: 1 sec<br>6) ATT sentence<br>Proprietary sentence or FURUNO sentence<br>Only P sentence: output rate of 0.1 sec<br>Accompanied with any of above sentences:<br>output rate of 0.2 sec<br><br>ATT sentence – True heading, pitching, rolling<br>\$PFEC, Gpatt, xxx.x, +xx.x, +xx.x<CR><LF><br>(Ver.1.5)<br>\$PFEC, Gpatt, xxx.x, +xx.x, +xx.x*hh<CR><LF><br>(Ver.2.0)<br><br>7) Signal level:<br>NAV OUT1: IEC 61162; NAV OUT2: RS-232C |

| Port Label | Connector Type | I/O | Signal     | Remarks   |
|------------|----------------|-----|------------|---|
| LOG/ALARM  | MJ7            | O   | Log signal | 200 pulse/nm or 400 pulse/nm (software), 0.5 A max.   |
|            |                |     | HDG alarm  | Heading alarm, 0.5 A max, normal close  |
| HDG IN     | MJ6            | I   | Heading    | Heading data in either AD10 or IEC 61162 (NMEA 0183) format (4800 bps) is automatically received. Priority of IEC 61162 (NMEA 0183) sentence is HDT>HDG>HDM.<br>The signal is selected through the menu during the period of internal heading sensor failure.<br>VBW/VHW/VLM may be input from a current indicator. |

**Note:** Each GPS receiver GPS1, GPS2, and GPS3 calculates VTG/GGA/GLL/ZDA. The output from HDG OUT and NAV OUT ports is one calculated by the GPS1. However, when the GPS1 is defective, the GPS2 replaces it. When both GPS1 and GPS2 are defective, the data calculated by the GPS3 is used.

## Parts Location

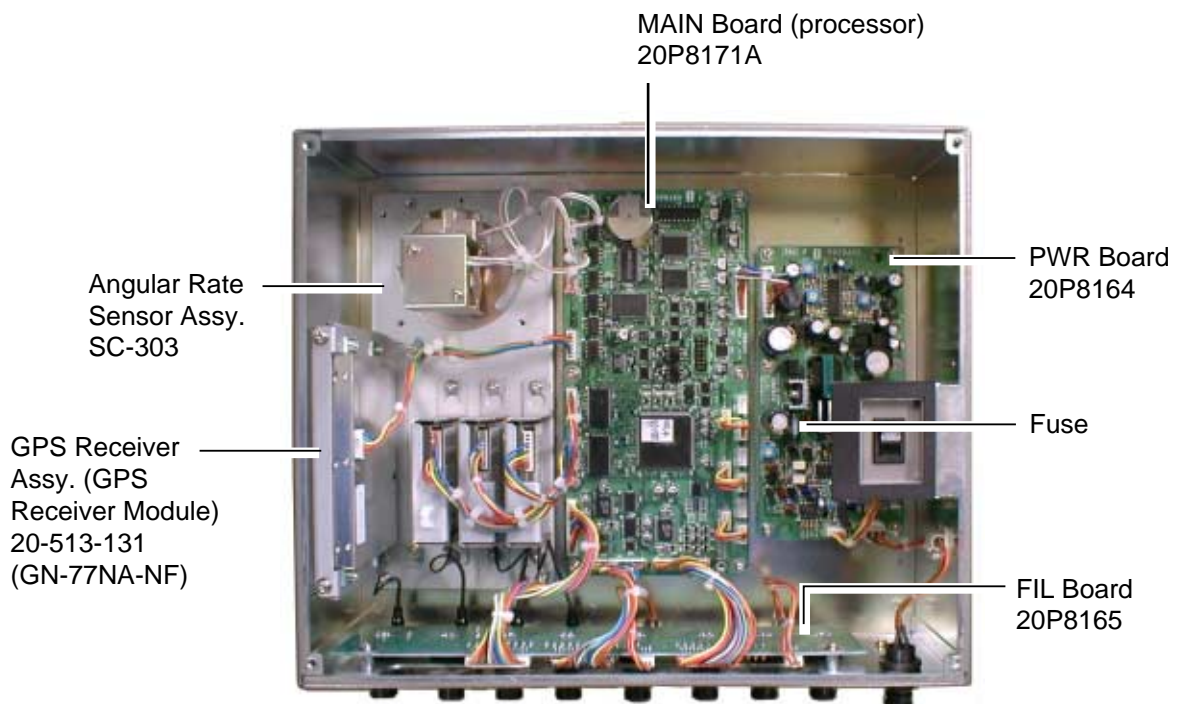

*Processor unit, cover removed*

## Parts List

This equipment contains complex modules in which fault diagnosis and repair down to component level are not practical (IMO A.694(17)/8.3.1. Only some discrete components are used. FURUNO Electric Co. Ltd. believes identifying these components is of no value for shipborne maintenance; therefore, they are not listed in this manual. Major modules can be located on the parts location photo on page A-5.

### FURUNO

#### ELECTRICAL PARTS LIST Sep. 2001

|          |                          |      |
|----------|--------------------------|------|
| Model    | SC-60                    |      |
| Unit     | SC-601<br>PROCESSOR UNIT |      |
| Ref.Dwg. | C7248-K01-A              | Page |
| Blk.No.  |                          |      |

| SYMBOL                       | TYPE                       | CODE No.    | REMARKS                               | SHIPPABLE ASSEMBLY |
|------------------------------|----------------------------|-------------|---------------------------------------|--------------------|
| <b>PRINTED CIRCUIT BOARD</b> |                            |             |                                       |                    |
| B1                           | 20P8171A, MAIN             | 004-380-270 | SC-601/601-D                          | X                  |
| B2                           | 20P8164, PWR               | 004-377-660 |                                       | X                  |
| B3                           | 20P8165, FIL               | 004-377-680 |                                       | X                  |
| <b>ASSEMBLY</b>              |                            |             |                                       |                    |
|                              | 20-513-131<br>(GN-77NA-NF) | 004-377-970 | GPS Receiver assy.                    | X                  |
|                              | GSC-001                    | 004-382-240 | Angular Rate<br>Sensor assy. (SC-303) | X                  |

# APPENDIX B

## Installation of Antenna Unit SC-603

### B.1 Mounting Considerations

See the mounting considerations on page 2-1 to select a suitable mounting location. (The drawings are for the antenna unit SC-303, but the guidelines are the same.)

### B.2 Installing the Antenna Unit

1. Screw in three antenna elements in the Antenna Base S. Remove Antenna Cover S and Arm cover S.

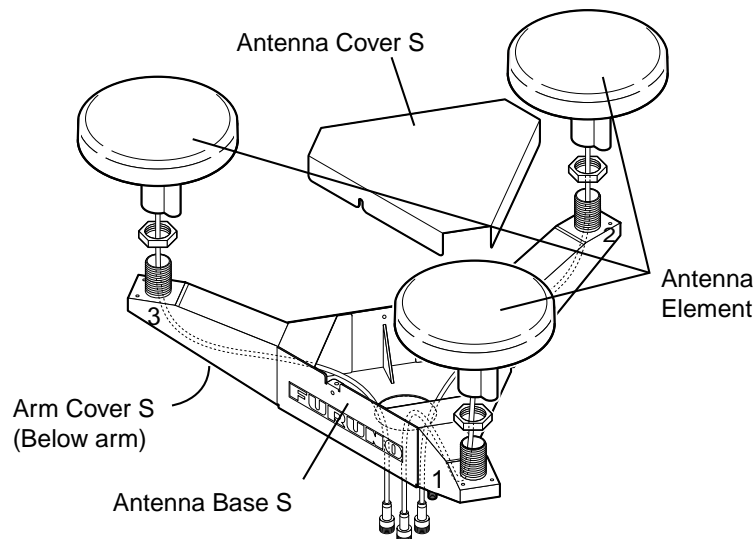

*Antenna unit SC-603*

2. Pass the coaxial cable from each antenna element through the center of the respective arm and then through the hole at the center of the antenna unit.
3. Orient the three antenna elements so that the protrusion on each faces the bow.

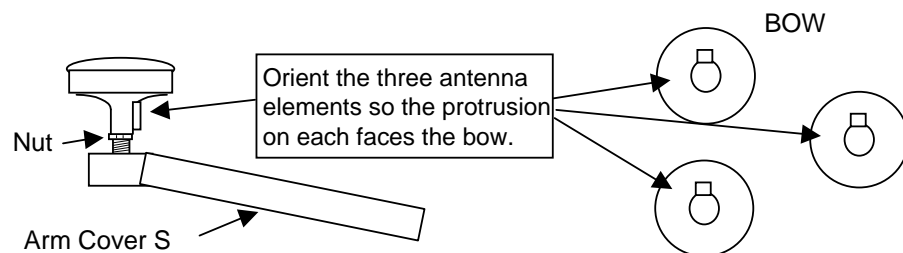

*How to orient the antenna elements*

- Making sure each antenna element is correctly oriented, fix each with its nut. Write the corresponding arm number on each coaxial cable, using a magic marker. (When connecting with the coaxial cables from the processor unit it is necessary to match correct antenna element number with coaxial cable color.)

|         |   |
|---------|---|
| Arm [1] | 1 |
| Arm [2] | 2 |
| Arm [3] | 3 |

- Temporarily fix the pedestal and support plate to the antenna mast as shown in the illustration below. (The pedestal and support plate will be welded to the antenna mast after confirming that the installation site is suitable, following paragraph 2.6 Initial Settings.)

**Note:** If U-bolts are used to temporarily fix the pedestal and support plate, DO NOT overtighten them – overtightening may deform the pedestal.

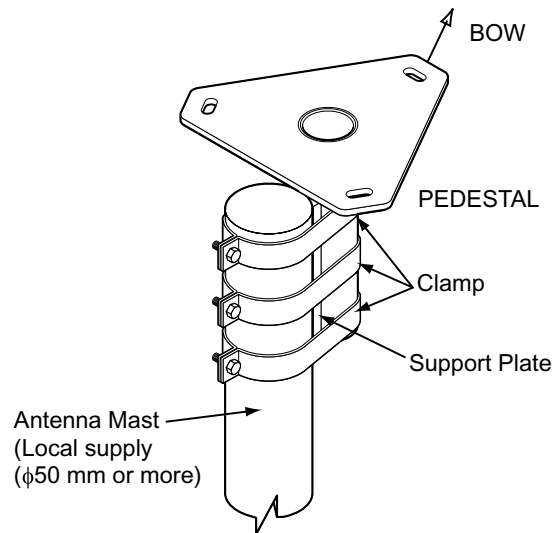

*How to temporarily fix the support plate and pedestal to the antenna mast*

- Set the antenna unit to the pedestal.

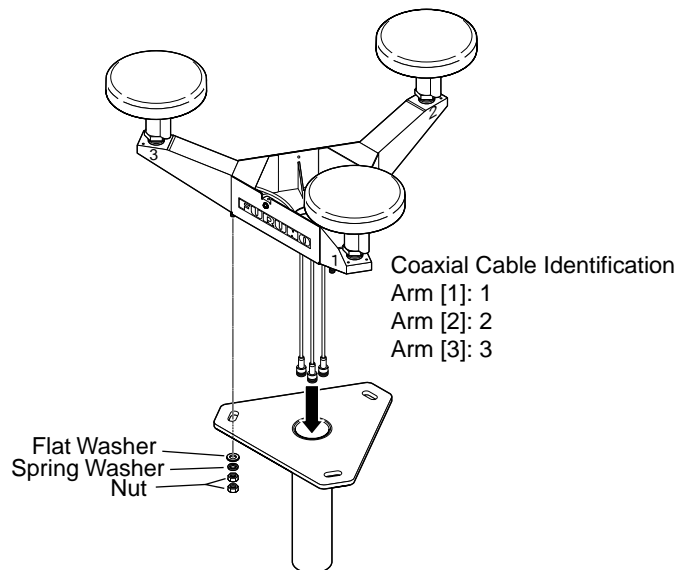

*Fixing antenna unit to pedestal*



- Orient the antenna unit as shown in the illustration below.

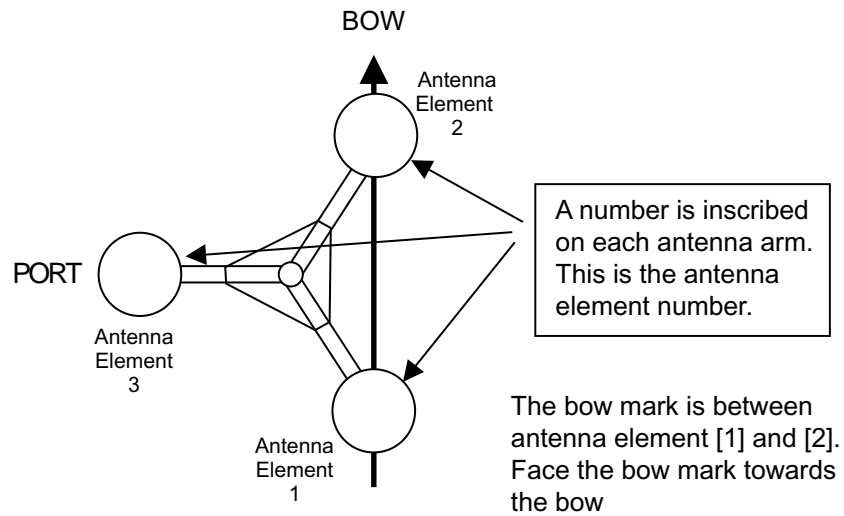

*Orienting the antenna unit*

|   |
|---|
|  <b>NOTICE</b> |
| The antenna unit should be positioned within $\pm 2.5^\circ$ of the bow.                        |

- Fasten the Antenna Cover S with three screws.

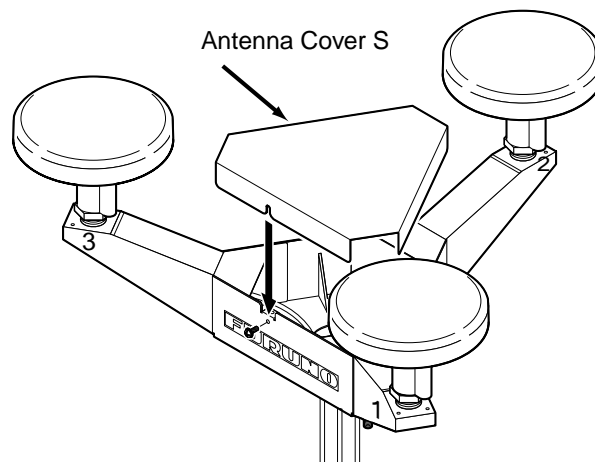

*Antenna unit SC-603*

- Follow the instructions in the paragraph 2.6 Initial Settings. If the installation site is suitable weld the antenna unit to the antenna mast as shown in the next paragraph.

## B.3 Welding the Antenna Unit

The antenna unit may be welded to the antenna mast if the satellite status display shows “OK.”

|  |
|--|
|  <b>NOTICE</b>  |
| <p><b>Use clamps to temporarily fix the pedestal and the support plate to the antenna mast.</b></p> <p>If U-bolts are used instead of clamps be sure not to overtighten them - the pedestal may become deformed.</p> |

1. Unfasten the coaxial cables and dismount the antenna unit.
2. Weld the pedestal and support plate to the antenna mast. Remove the clamps used to temporarily fasten the pedestal and support plate.
3. Fasten the coaxial cables and fix the antenna unit.
4. Wrap the antenna connector with self-vulcanizing tape and then vinyl tape for waterproofing as shown in the illustration below. Tie tape ends with cable ties to prevent unraveling.



*Waterproofing the antenna connector*

5. Coat the three screws fixing the Antenna Cover S with Three Bond 1211 (supplied).

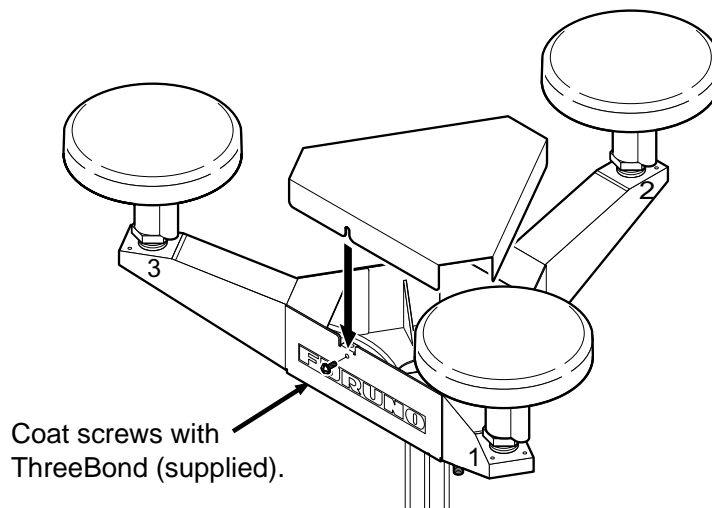

*Antenna unit SC-603*

6. Look at the heading indication on the display. If the heading error is between 5° and 10°, loosen the nut at the center of the antenna unit and adjust antenna orientation, while watching the heading indication on the display.

7. Make a loop in the antenna cable as shown in the illustration below. Fasten the antenna cable to the antenna mast with cable ties.

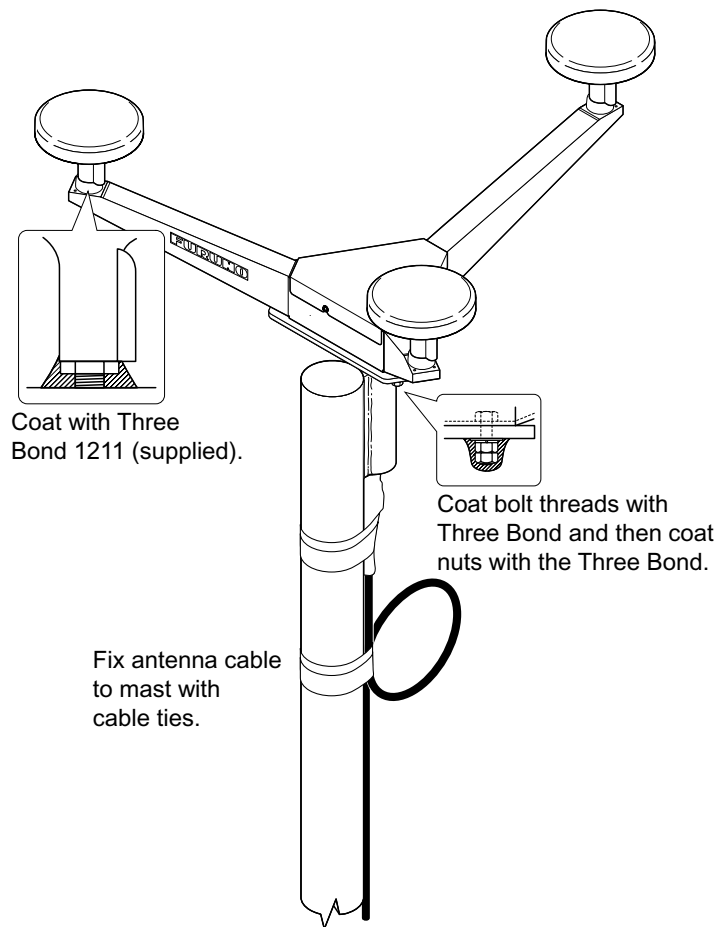

*Fastening the antenna cable*

8. Coat bolt threads and nuts at the bottom of each antenna element with Three Bond 1211.
9. Paint pedestal and support plate with anti-corrosive paint.
10. If necessary, attach the “bird-repellent fixtures” (supplied) to each antenna element and the Antenna Cover S as shown below.

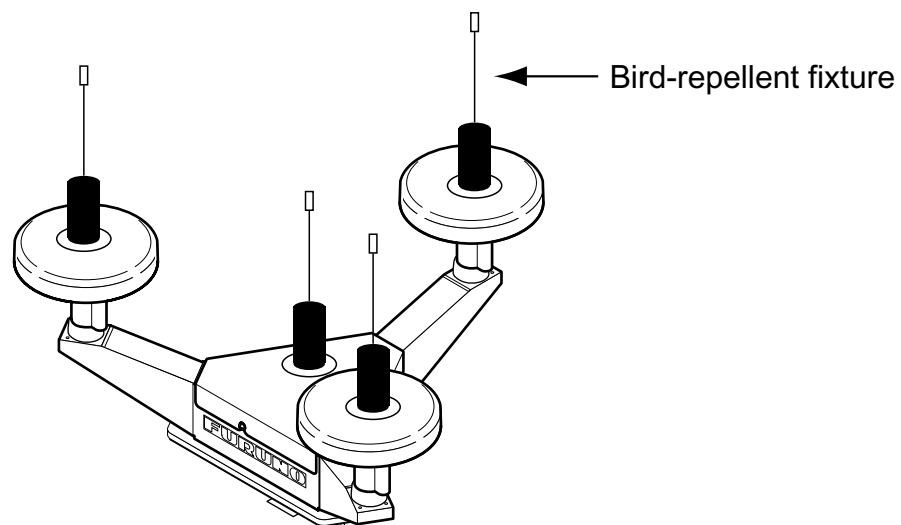

*Antenna element*

This page is intentionally left blank.

# PACKING LIST

## SC-60/120 (J/E)

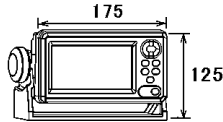
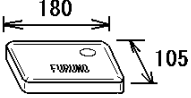
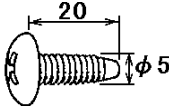

| NAME                               | OUTLINE   | DESCRIPTION/CODE              | Q'TY |
|------------------------------------|---|-------------------------------|------|
| <b>ユニット UNIT</b>                   |   |                               |      |
| 表示部<br>DISPLAY UNIT                |  | SC-602<br>004-377-310 **      | 1    |
| <b>付属品 ACCESSORIES FP14-02801</b>  |   |                               |      |
| 保護カバー<br>COVER                     |  | 20-016-1091-2<br>100-297-032  | 1    |
| <b>工事材料 INSTALLATION MATERIALS</b> |   |                               |      |
| +トラスタップネジ<br>+TAPPING SCREW        |  | 5X20 SUS304 1ヶ<br>000-802-081 | 4    |

コード末尾に[\*\*]の付いたユニットは代表の型式/コードを表示しています。  
DOUBLE ASTERISK DENOTES COMMONLY USED EQUIPMENT.

(略図の寸法は、参考値です。 DIMENSIONS IN DRAWING FOR REFERENCE ONLY.)

## PACKING LIST

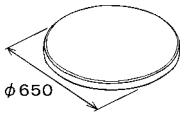
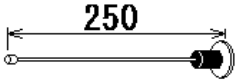
SC-303

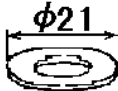
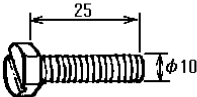
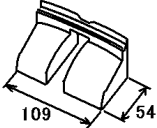
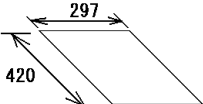
| NAME                                  | OUTLINE   | DESCRIPTION/CODE             | Q'TY |
|---------------------------------------|---|------------------------------|------|
| <b>ユニット</b><br>UNIT                   |   |                              |      |
| GPSアンテナ<br>GPS ANTENNA                |    | SC-303<br>000-041-925        | 1    |
| <b>工事材料</b><br>INSTALLATION MATERIALS |   | <b>CP20-02231</b>            |      |
| 鳥よけ<br>BIRD-REPELLENT FIXTURE         |    | 20-024-3101-2<br>100-315-302 | 9    |
| ハネ座金<br>SPRING WASHER                 |    | M10 SUS304<br>000-864-261    | 4    |
| ミカキ平座金<br>FLAT WASHER                 |    | M10 SUS304<br>000-864-131    | 4    |
| 六角ボルト 刃割<br>HEX. BOLT (SLOTTED HEAD)  |   | M10X25 SUS304<br>000-862-308 | 4    |
| ケーブルカバー<br>CABLE COVER                |  | 20-020-3213-1<br>100-291-511 | 1    |
| <b>図書</b><br>DOCUMENT                 |   |                              |      |
| 型紙<br>TEMPLATE                        |  | C72-00303-<br>000-149-150    | 1    |

(略図の寸法は、参考値です。 DIMENSIONS IN DRAWING FOR REFERENCE ONLY.)C7248-Z02-C

**FURUNO**

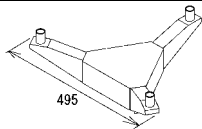
|  |                                       | CODE NO.  | 004-377-570             | 20AT-X-9401 -1 |                    |
|--|---------------------------------------|---|-------------------------|----------------|--------------------|
|  |                                       | TYPE  | CP20-02201              | 1/1            |                    |
| <b>工事材料表</b><br>INSTALLATION MATERIALS |                                       |   |                         |                |                    |
| 番号<br>NO.                              | 名称<br>NAME                            | 略図<br>OUTLINE   | 型名 / 規格<br>DESCRIPTIONS | 数量<br>Q'TY     | 用途 / 備考<br>REMARKS |
| 1                                      | アンテナベース組品(S)<br>ANTENNA BASE ASSY.(S) |  | CP20-02201              | 1              |                    |
|  | CODE NO.                              |   | 004-377-570             |                |                    |



20AT-X-9401

(略図の寸法は、参考値です。 DIMENSIONS IN DRAWING FOR REFERENCE ONLY.)

FURUNO ELECTRIC CO., LTD.

**FURUNO**

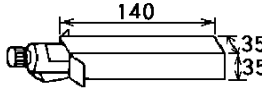
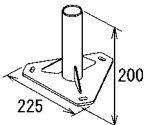
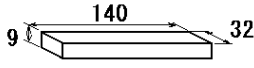
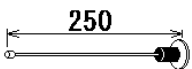
|          |             |                       |
|----------|-------------|-----------------------|
| CODE NO. | 004-377-590 | 20AT-X-9404 -3<br>1/1 |
| TYPE     | CP20-02202  |                       |

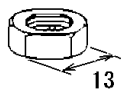
| 工事材料表<br>INSTALLATION MATERIALS |                               |   |                                       |            |                    |
|---------------------------------|-------------------------------|---|---------------------------------------|------------|--------------------|
| 番号<br>NO.                       | 名称<br>NAME                    | 略図<br>OUTLINE   | 型名 / 規格<br>DESCRIPTIONS               | 数量<br>Q'TY | 用途 / 備考<br>REMARKS |
| 1                               | シリボンド<br>SEALANT              |    | 1211 50G<br>CODE NO. 000-854-118      | 1          |                    |
| 2                               | 固定用金具S<br>MOUNTING BASE       |    | 20-019-3351-2<br>CODE NO. 100-284-842 | 1          |                    |
| 3                               | 補助金具<br>ATTACHMENT PLATE      |    | 20-019-3352-1<br>CODE NO. 100-284-851 | 1          |                    |
| 4                               | 鳥よけ<br>BIRD-REPELLENT FIXTURE |   | 20-024-3101-2<br>CODE NO. 100-315-302 | 4          |                    |
| 5                               | バネ座金<br>SPRING WASHER         |  | M8 SUS304<br>CODE NO. 000-864-262     | 3          |                    |
| 6                               | ミガキ平座金<br>FLAT WASHER         |  | M8 SUS304<br>CODE NO. 000-864-130     | 3          |                    |
| 7                               | 六角ナット 1種<br>HEX.NUT           |  | M8 SUS304<br>CODE NO. 000-863-110     | 6          |                    |

20AT-X-9404

FURUNO ELECTRIC CO., LTD.  
(略図の寸法は、参考値です。 DIMENSIONS IN DRAWING FOR REFERENCE ONLY.)



**FURUNO**

|          |             |                      |
|----------|-------------|----------------------|
| CODE NO. | 004-378-110 | 20AT-X-9408-0<br>1/1 |
| TYPE     | CP20-02230  |                      |

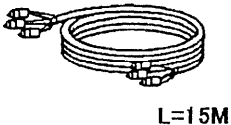
| 工事材料表<br>INSTALLATION MATERIALS |                       |  |  |            |                  |
|---------------------------------|-----------------------|--|--|------------|------------------|
| 番号<br>NO.                       | 名称<br>NAME            | 略図<br>OUTLINE  | 型名/規格<br>DESCRIPTIONS                  | 数量<br>Q'TY | 用途/備考<br>REMARKS |
| 1                               | ケーブル組品<br>CABLE ASSY. |  <p>L=15M</p> | TPPX6-3D2V-15M<br>CODE NO. 000-143-559 | 1          |                  |



DWG NO. C7248-M06- A

FURUNO ELECTRIC CO., LTD.

(略図の寸法は、参考値です。 DIMENSIONS IN DRAWING FOR REFERENCE ONLY.)

**FURUNO**

|          |  |                |
|----------|--|----------------|
| CODE NO. |  | 20AT-X-9406 -2 |
| TYPE     |  | 1/1            |

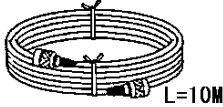
| 工事材料表<br>INSTALLATION MATERIALS |                         |  |                         |            |                    |
|---------------------------------|-------------------------|--|-------------------------|------------|--------------------|
| 番号<br>NO.                       | 名称<br>NAME              | 略図<br>OUTLINE  | 型名 / 規格<br>DESCRIPTIONS | 数量<br>Q'TY | 用途 / 備考<br>REMARKS |
| 1                               | ケーブル組品<br>POWER CABLE   |  L=3.5M | MJ-A3SPF0013-035        | 1          |                    |
|                                 |                         |  | CODE NO.                |            |                    |
| 2                               | ケーブル組品MJ<br>CABLE ASSY. |  L=10M  | MJ-A6SPF0007-100        | 1          |                    |
|                                 |                         |  | CODE NO.                |            |                    |
| 3                               | ケーブル組品MJ<br>CABLE ASSY. |  L=10M  | MJ-A7SPF0006-100        | 1          |                    |
|                                 |                         |  | CODE NO.                |            |                    |

FURUNO ELECTRIC CO., LTD.  
(略図の寸法は、参考値です。 DIMENSIONS IN DRAWING FOR REFERENCE ONLY.)

**FURUNO**

|          |             |                      |
|----------|-------------|----------------------|
| CODE NO. | 004-377-610 | 20AT-X-9407-1<br>1/1 |
| TYPE     | CP20-02221  |                      |

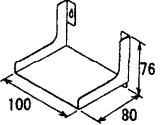
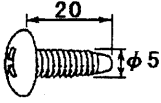
| 工事材料表<br>INSTALLATION MATERIALS |                                   |   |                       |            |                  |
|---------------------------------|-----------------------------------|---|-----------------------|------------|------------------|
| 番号<br>NO.                       | 名称<br>NAME                        | 略図<br>OUTLINE   | 型名/規格<br>DESCRIPTIONS | 数量<br>Q'TY | 用途/備考<br>REMARKS |
| 1                               | 壁掛用取付板<br>BULKHEAD MOUNTING PLATE |  | 20-019-1021-0         | 1          |                  |
|                                 |                                   |   | CODE NO.              |            |                  |
| 2                               | +トラスタップネジ<br>+TAPPING SCREW       |  | 5X20 SUS304 1ヶ        | 4          |                  |
|                                 |                                   |   | CODE NO.              |            |                  |

DWG NO.  
C7248-M05- B

FURUNO ELECTRIC CO., LTD.

(略図の寸法は、参考値です。 DIMENSIONS IN DRAWING FOR REFERENCE ONLY.)

# FURUNO

|          |             |                |
|----------|-------------|----------------|
| CODE NO. | 004-377-600 | 20AT-X-9301 -0 |
| TYPE     | SP20-00901  | BOX NO. P      |

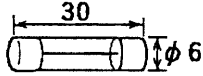
| SHIP NO.   | SPARE PARTS LIST FOR      |   | U S E                |              |         | SETS PER VESSEL  |
|------------|---------------------------|---|----------------------|--------------|---------|------------------|
|            | SC-60/120                 | サテライトコンパス<br>SATELLITE COMPASS  |                      |              |         |                  |
| ITEM NO.   | NAME OF PART              | OUTLINE   | DWG. NO. OR TYPE NO. | QUANTITY     |         | REMARKS/CODE NO. |
|            |                           |   |                      | WORKING      |         |                  |
|            |                           |   |                      | PER SET      | PER VES | SPARE            |
| 1          | ヒューズ<br>FUSE              |  | FGBO-A 3A<br>AC125V  | 1            |         | 3                |
|            |                           |   |                      |              |         | 000-549-063      |
|            |                           |   |                      |              |         |                  |
|            |                           |   |                      |              |         |                  |
|            |                           |   |                      |              |         |                  |
|            |                           |   |                      |              |         |                  |
|            |                           |   |                      |              |         |                  |
|            |                           |   |                      |              |         |                  |
|            |                           |   |                      |              |         |                  |
|            |                           |   |                      |              |         |                  |
|            |                           |   |                      |              |         |                  |
|            |                           |   |                      |              |         |                  |
|            |                           |   |                      |              |         |                  |
| MFR'S NAME | FURUNO ELECTRIC CO., LTD. |   | DWG NO.              | C7248-P01- A |         | 1/1              |

(略図の寸法は、参考値です。 DIMENSIONS IN DRAWING FOR REFERENCE ONLY.)

# PACKING LIST

A - 9  
14CB-X-9853-0 1/1

GR-800-1-S

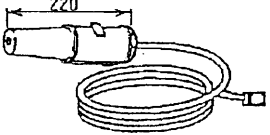
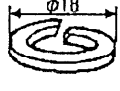

| NAME                               | OUTLINE   | DESCRIPTION/CODE No.      | Q'TY |
|------------------------------------|---|---------------------------|------|
| <b>ユニット UNIT</b>                   |   |                           |      |
| アンテナ部<br>ANTENNA UNIT              |  | GR-8<br>000-040-660       | 1    |
| <b>工事材料 INSTALLATION MATERIALS</b> |   |                           |      |
| ハネ座金<br>SPRING WASHER              |  | M10 SUS304<br>000-864-261 | 1    |

C4020-Z03- A

(略図の寸法は、参考値です。 DIMENSIONS IN DRAWING FOR REFERENCE ONLY.)

**FURUNO**

|          |  |                |
|----------|--|----------------|
| CODE NO. |  | 20AG-X-9404 -1 |
| TYPE     |  | 1/1            |

| 工事材料表<br>INSTALLATION MATERIALS |                                   | GP-80, GP-90, SC-55, GP-3500/F<br>GP-1850, GP-1650, FA-100, GP-1640/F<br>SC-60/120, GD/GP-280/680/380 |                         |            |                    |
|---------------------------------|-----------------------------------|---|-------------------------|------------|--------------------|
| 番号<br>NO.                       | 名称<br>NAME                        | 略図<br>OUTLINE   | 型名 / 規格<br>DESCRIPTIONS | 数量<br>Q'TY | 用途 / 備考<br>REMARKS |
| 1                               | アンテナケーブル組品<br>ANTENNA CABLE ASSY. | <br>L=30M            | 8D-FB-CV *30M*          | 1          | 選択 TO BE SELECTED  |
|                                 |                                   |   | CODE NO.                |            |                    |
| 2                               | ケーブル組品<br>CABLE ASSY.             | <br>L=50M            | 8D-FB-CV *50M*          | 1          | 選択 TO BE SELECTED  |
|                                 |                                   |   | CODE NO.                |            |                    |

FURUNO ELECTRIC CO., LTD.  
(略図の寸法は、参考値です。 DIMENSIONS IN DRAWING FOR REFERENCE ONLY.)

**FURUNO**

|          |             |                |
|----------|-------------|----------------|
| CODE NO. | 004-372-420 | 20AG-X-9405 -1 |
| TYPE     | CP20-01701  | 1/1            |

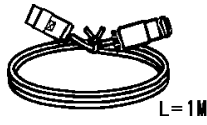
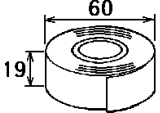
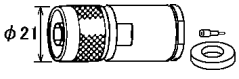
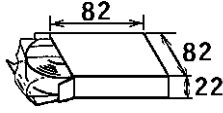
| 工事材料表<br>INSTALLATION MATERIALS |                                 |  |                           |            |                  |
|---------------------------------|---------------------------------|--|---------------------------|------------|------------------|
| 番号<br>NO.                       | 名称<br>NAME                      | 略図<br>OUTLINE  | 型名/規格<br>DESCRIPTIONS     | 数量<br>Q'TY | 用途/備考<br>REMARKS |
| 1                               | 変換ケーブル組品<br>CONVERT CABLE ASSY. |   | NJ-TP-3DXV-1              | 2          |                  |
|                                 |                                 |  | CODE NO. 000-123-809      |            |                  |
| 2                               | ビニールテープ<br>VINYL TAPE           |   | N0360 02X19X10000<br>加 工品 | 1          |                  |
|                                 |                                 |  | CODE NO. 000-835-215      |            |                  |
| 3                               | コネクタ(N)<br>CONNECTOR            |   | N-P-8DFB                  | 1          |                  |
|                                 |                                 |  | CODE NO. 000-111-549      |            |                  |
| 4                               | 絶縁テープ<br>SELF-BONDING TAPE      |  | Uテープ 0.5X19X5M            | 1          |                  |
|                                 |                                 |  | CODE NO. 000-800-985      |            |                  |

(略図の寸法は、参考値です。 DIMENSIONS IN DRAWING FOR REFERENCE ONLY.)

FURUNO ELECTRIC CO., LTD.

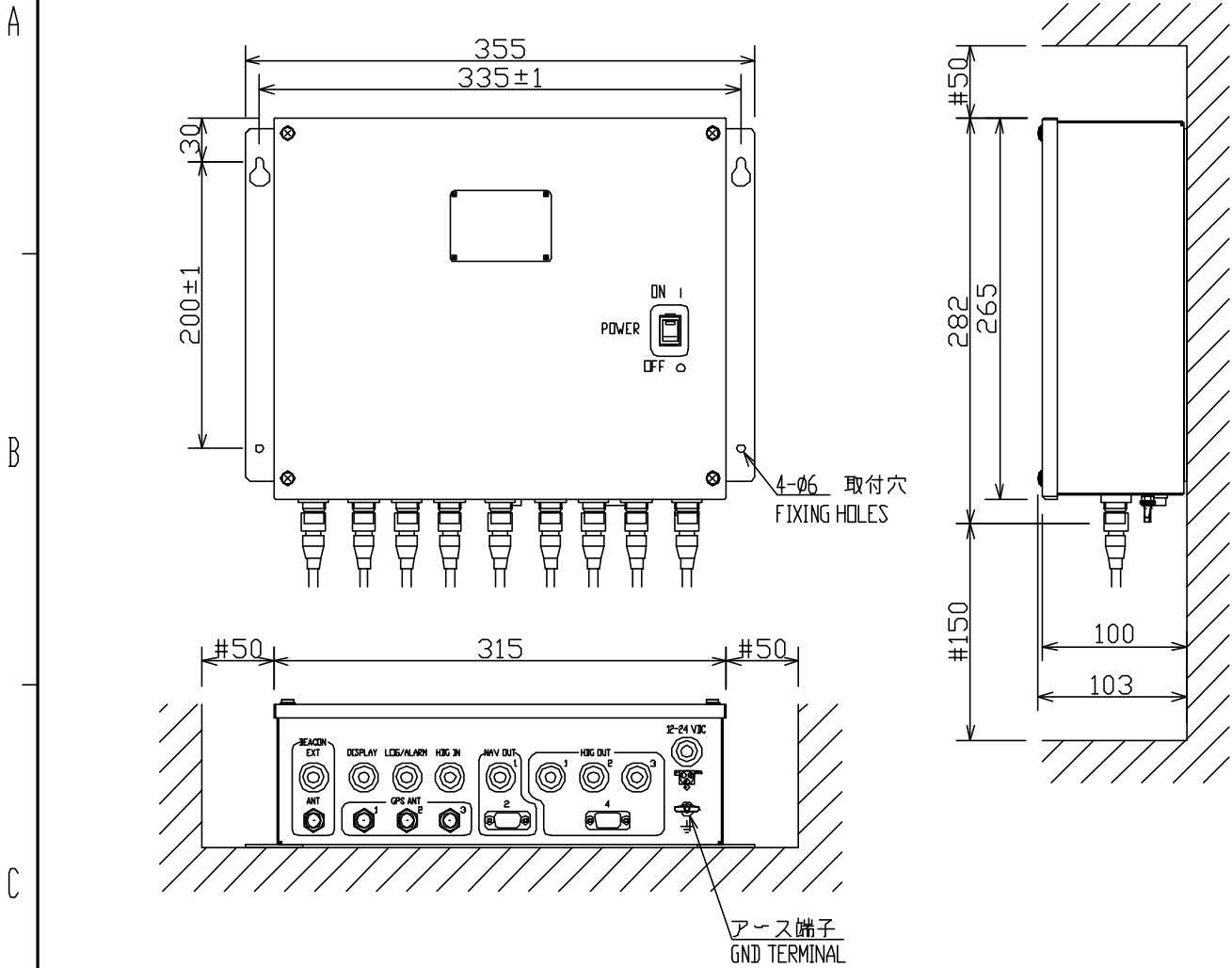

注 記

- 1) 装備ケーブルはサービス時、本体を前方に十分引き出せるよう余裕を持たせること。
- 2) 取付用ネジはトラスタッピンネジ呼び径5×20を使用のこと。
- 3) 指定外寸法公差は表1による。
- 4) #印寸法は最小サービス空間寸法とする。

NOTE

- 1. KEEP SUFFICIENT CABLE LENGTH BEHIND THE UNIT FOR MAINTENANCE.
- 2. USE TAPPING SCREWS 5x20 FOR FIXING THE UNIT.
- 3. TABLE 1 INDICATES TOLERANCE OF DIMENSIONS.
- 4. #: RECOMMENDED SERVICE CLEARANCE.

| 寸法区分 (mm)<br>DIMENSION | 公差 (mm)<br>TOLERANCE |
|------------------------|----------------------|
| 0 < L ≤ 50             | ±1.5                 |
| 50 < L ≤ 100           | ±2.5                 |
| 100 < L ≤ 500          | ±3                   |

表 1 TABLE 1

|                            |                        |                                     |
|----------------------------|------------------------|-------------------------------------|
| DRAWN<br>2003. May H. MAKI |                        | TITLE<br>SC-601/601D/1201/1201D/551 |
| CHECKED<br>Takahashi T.    |                        | 名称<br>演算部                           |
| APPROVED<br>Takahashi T.   | SC-60/120/55           | 外寸図                                 |
| SCALE<br>1/5               | MASS<br>3.6 ±10%<br>kg | NAME<br>PROCESSOR UNIT              |
| DWG.No.<br>C7248-G01-E     | 20-019-1000-G0         | OUTLINE DRAWING                     |



4

3

2

1

表 1 TABLE 1

| 寸法区分 (m.m)<br>DIMENSION | 公差 (m.m)<br>TOLERANCE |
|-------------------------|-----------------------|
| 0 < L ≤ 50              | ± 1.5                 |
| 50 < L ≤ 100            | ± 2.5                 |
| 100 < L ≤ 500           | ± 3                   |

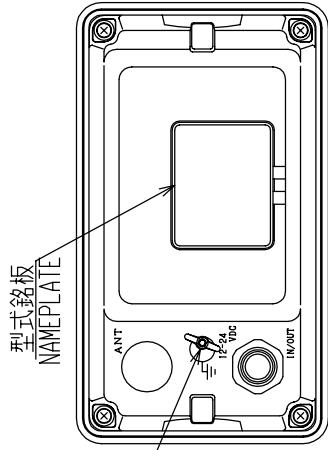

型式銘板  
NAMEPLATE

アース端子  
GND TERMINAL

矢視 A VIEW A

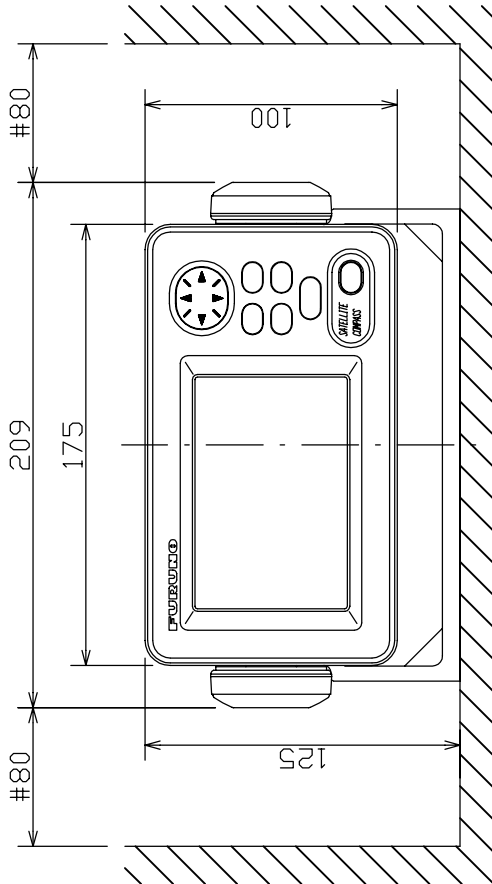
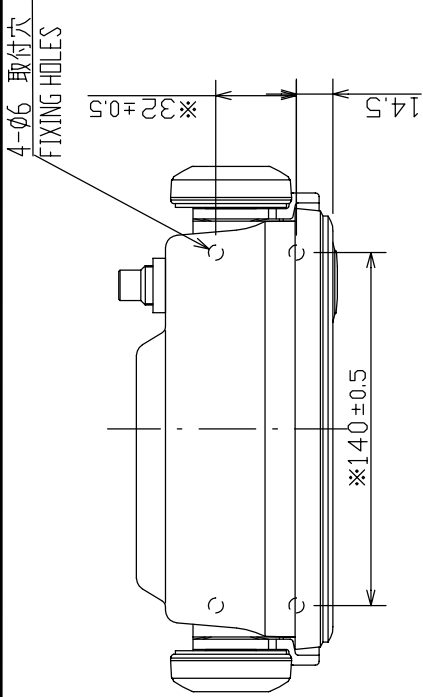
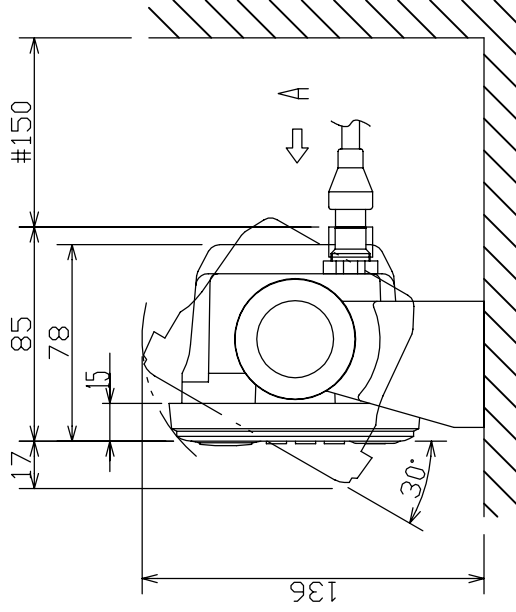

- 注 記
- 1) 装備ケーブルはサービス時、表示部を前方に十分引き出せるよう余裕を持たせること。
  - 2) ※印寸法は取付穴位置寸法とする。
  - 3) 取付用ネジはトラスタップピング呼び径5×20を使用のこと。
  - 4) 指定外寸法公差は表1による。
  - 5) #印寸法は最小サービス空間寸法とする。
- NOTE
1. KEEP SUFFICIENT CABLE LENGTH BEHIND THE UNIT FOR MAINTENANCE.
  2. ※ DIMENSIONS FOR FIXING HOLE POSITIONS.
  3. USE TAPPING SCREWS 5x20 FOR FIXING THE UNIT.
  4. TABLE 1 INDICATES TOLERANCE OF DIMENSIONS WHICH IS NOT SPECIFIED.
  5. # MINIMUM SERVICE CLEARANCE.

|                        |                            |                                      |
|------------------------|----------------------------|--------------------------------------|
| DRAWN<br>No. 17 04     | E. MIYOSHI<br>Takahashi T. | TITLE<br>SC-502/602                  |
| CHECKED                | SC-50/110                  | 名称<br>表示部 (卓上装備)                     |
| APPROVED<br>Y. Hatai   | SC-60/120/155              | 外寸図                                  |
| SCALE<br>1/3           | FORM<br>MASS 0.55 kg       | NAME<br>DISPLAY UNIT (DESKTOP MOUNT) |
| FIG.No.<br>C7248-G02-H | 20-024-200G-0              | OUTLINE DRAWING                      |

表 1 TABLE 1

| 寸法区分 (mm)<br>DIMENSIONS | 公差 (mm)<br>TOLERANCE |
|-------------------------|----------------------|
| 0 < L ≤ 50              | ±1.5                 |
| 50 < L ≤ 100            | ±2.5                 |
| 100 < L ≤ 500           | ±3                   |

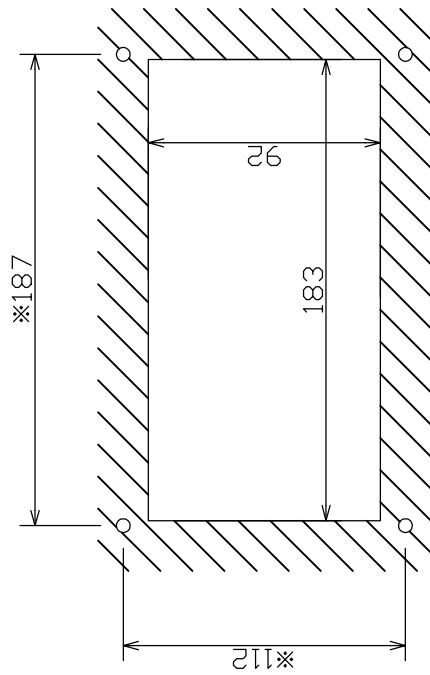
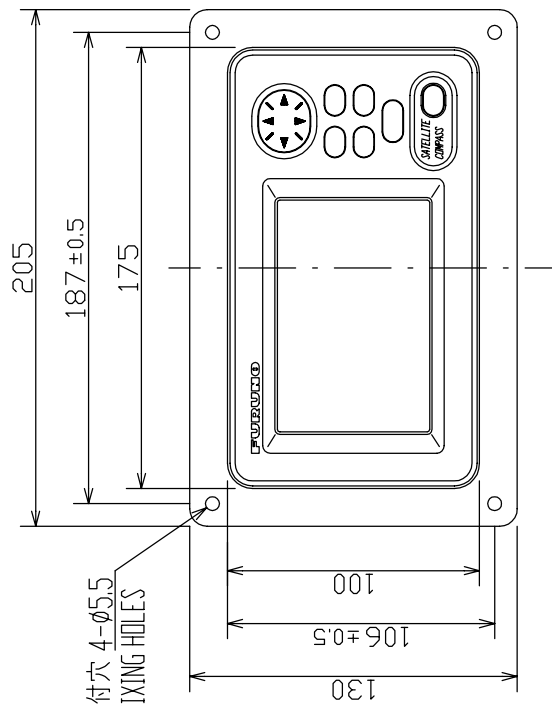
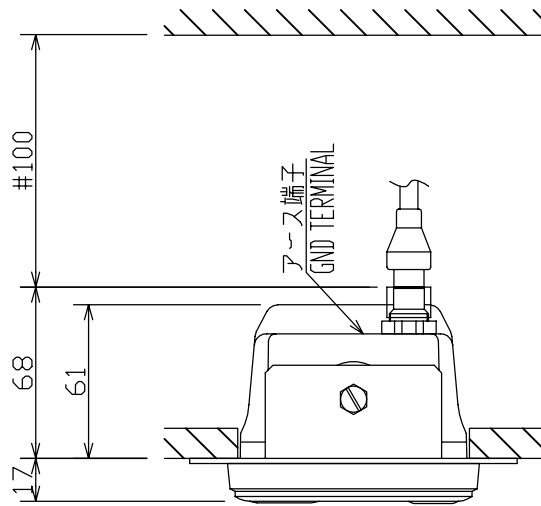

取付穴寸法図 (参考図)  
CUTOUT DIMENSIONS

- 注 記
- ※印寸法は取付穴位置寸法とする。
  - 取付用ネジはトラスタップピンネジ呼び径5×20を使用のこと。
  - 指定外寸法公差は表1による。
  - ※印寸法は最小サービス空間寸法とする。

- NOTE
- ※: DIMENSIONS FOR FIXING HOLE POSITIONS.
  - USE TAPPING SCREWS 5x20 FOR FIXING THE UNIT.
  - TABLE 1 INDICATES TOLERANCE OF DIMENSIONS WHICH IS NOT SPECIFIED.
  - #: MINIMUM SERVICE CLEARANCE.

|                    |                            |                                      |
|--------------------|----------------------------|--------------------------------------|
| DRAWN<br>No. 17/04 | E. MIYOSHI<br>Takahashi T. | TITLE<br>SC-502/602                  |
| CHECKED            |                            | 名称<br>表示部 (埋込装備 F)                   |
| APPROVED           | Y. Hatai                   | 外寸図                                  |
| SCALE<br>1/3       | MASS<br>0.67 kg            | NAME<br>DISPLAY UNIT (FLUSH MOUNT F) |
| DWG. No.           | C7248-G03-G                | 20-024-210G-0                        |
|                    |                            | OUTLINE DRAWING                      |

表 1 TABLE 1

| 寸法区分 (mm)<br>DIMENSIONS | 公差 (mm)<br>TOLERANCE |
|-------------------------|----------------------|
| L ≤ 50                  | ±1.5                 |
| 50 < L ≤ 100            | ±2.5                 |
| 100 < L ≤ 500           | ±3                   |

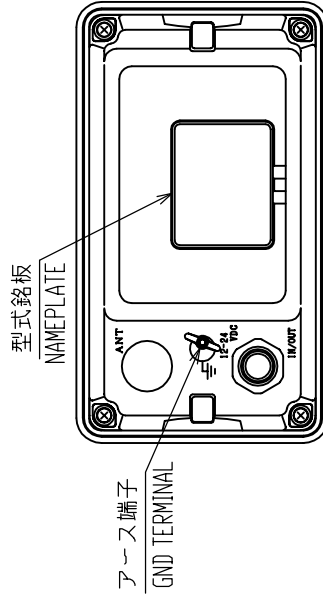
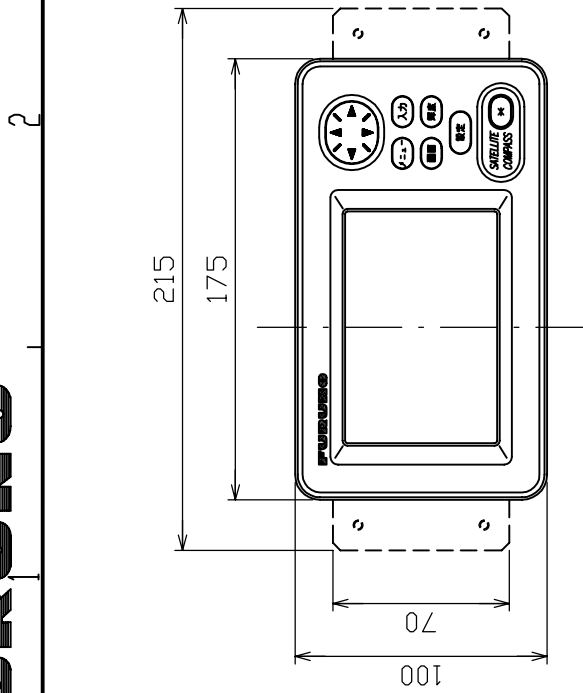
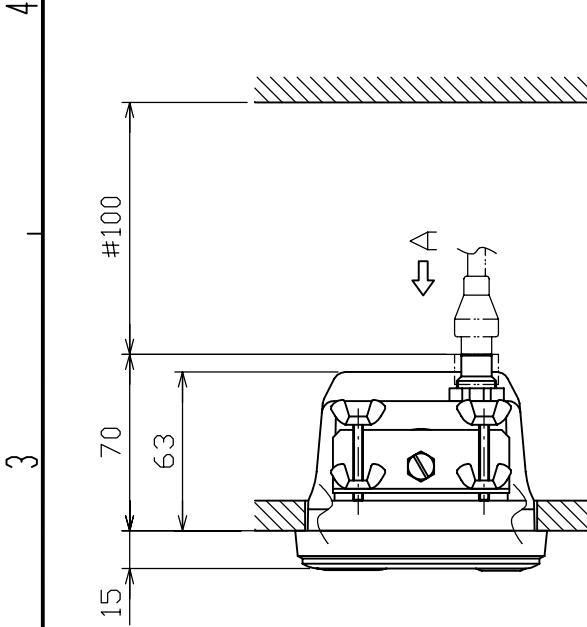

矢視 A  
VIEW A

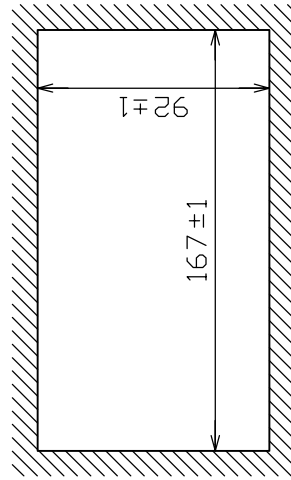

取付穴寸法図(参考図)

CUTOUT DIMENSIONS

- 注記 1) 指定外寸公差は表 1 による。  
 2) #印寸法は最小サービス空間寸法とする。
- NOTE 1. TABLE 1 INDICATES TOLERANCE OF DIMENSIONS WHICH IS NOT SPECIFIED.  
 2. # MINIMUM SERVICE CLEARANCE.

|                    |              |                 |                              |
|--------------------|--------------|-----------------|------------------------------|
| DRAWN<br>No. 17/04 | E. MIYOSHI   | TITLE           | SC-502/602                   |
| CHECKED            | Takahashi T. | 名称              | 表示部 (埋込装備 S)                 |
| APPROVED           | Y. Hatai     | 外寸図             |                              |
| SCALE              | 1/3          | NAME            | DISPLAY UNIT (FLUSH MOUNT S) |
| DRG.No.            | C7248-G04-F  | OUTLINE DRAWING |                              |
|                    |              |                 | 20-024-220G-0                |



表 1

| 寸法区分 (mm)<br>DIMENSIONS | 公差 (mm)<br>TOLERANCE |
|-------------------------|----------------------|
| L ≤ 50                  | ±1.5                 |
| 50 < L ≤ 100            | ±2.5                 |
| 100 < L ≤ 500           | ±3                   |
| 500 < L ≤ 1000          | ±4                   |

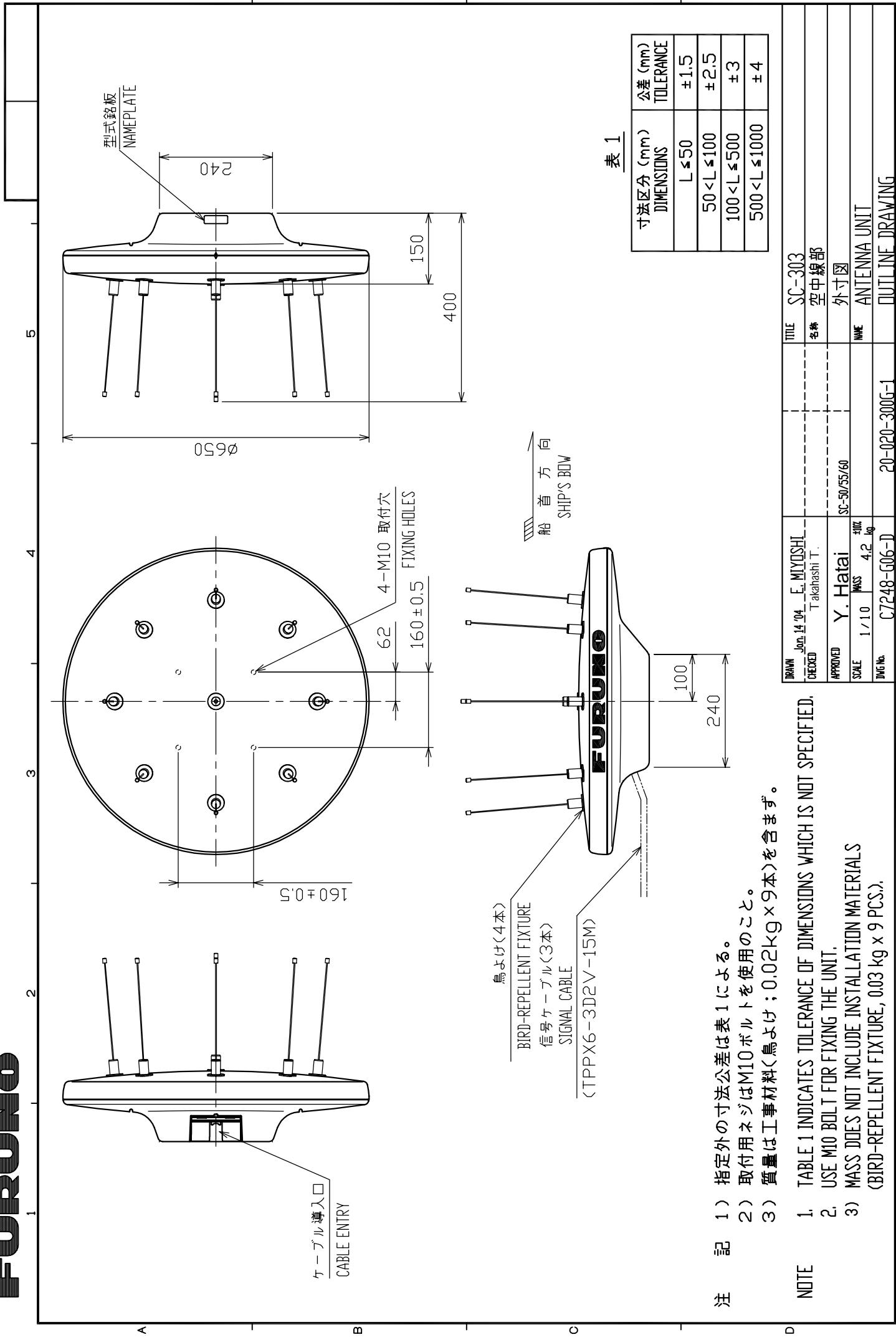
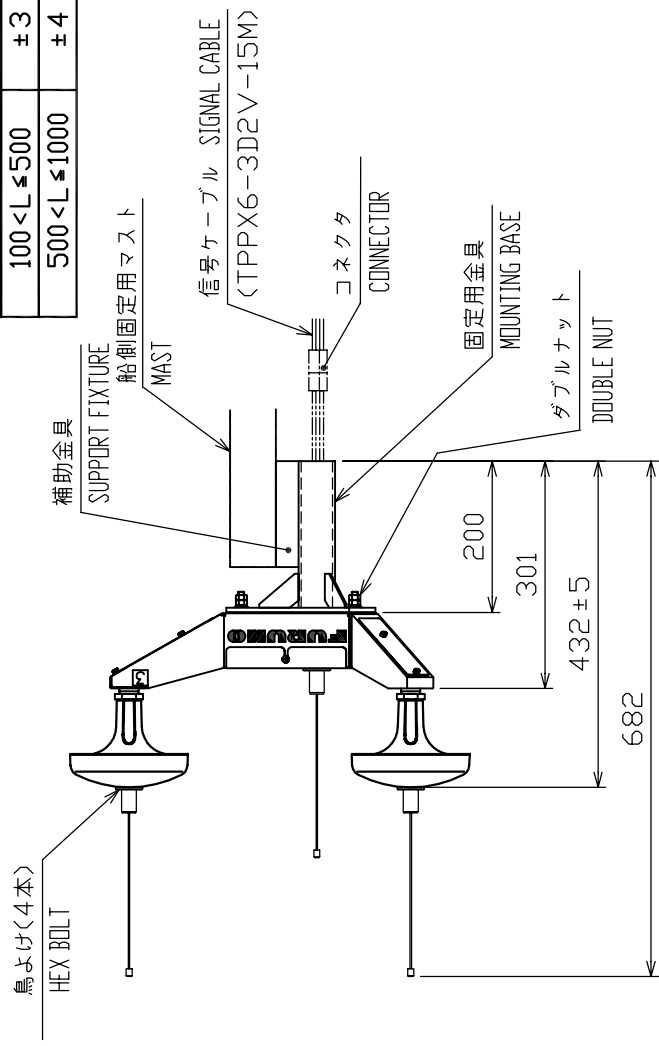
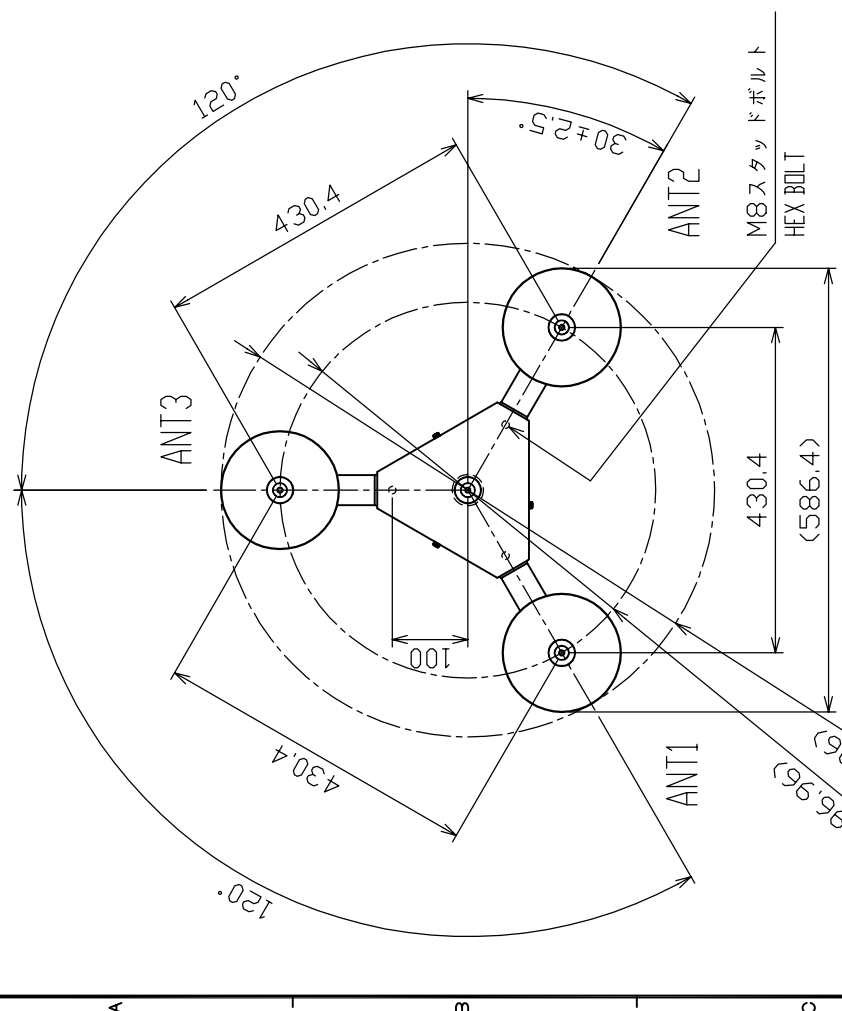

- 注 記
- 1) 指定外の寸法公差は表1による。
  - 2) 取付けは補助金具を溶接し、しっかりと固定のこと。
  - 3) 質量は工事材料(鳥よけ; 0.02kg×4本、固定用金具; 2kg、補助金具、M8ナット、SW、PW、スリーポンF1211)を含まず。

- NOTE
1. TABLE 1 INDICATES TOLERANCE OF DIMENSIONS WHICH IS NOT SPECIFIED.
  2. WELD SUPPORT FIXTURE.
  3. MASS DOES NOT INCLUDE INSTALLATION MATERIALS (BIRD-REPELLENT FIXTURE, 0.02 kg x 4 PCS; MOUNTING BASE, 2 kg; SUPPORT FIXTURE, M8 NUT, STEEL WASHER, PLAIN WASHER, THREEBOND SILICONE RUBBER 1211).

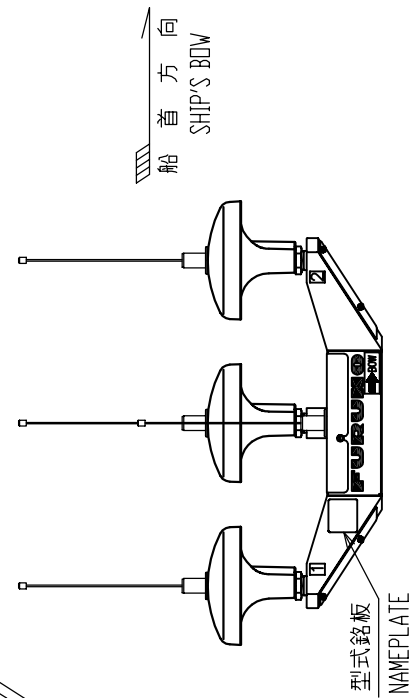

|          |                      |       |                 |
|----------|----------------------|-------|-----------------|
| DRAWN    | Job. 15/04_E_MYOSHII | TITLE | SC-603          |
| CHECKED  | Takahashi T.         | 名称    | 空中線部            |
| APPROVED | Y. Hatai             | 外寸図   |                 |
| SCALE    | 1/10                 | 図名    | ANTENNA UNIT    |
| FIG No.  | C7248-G05-C          | 図号    | 20-019-310G-1   |
|          |                      | 図名    | OUTLINE DRAWING |

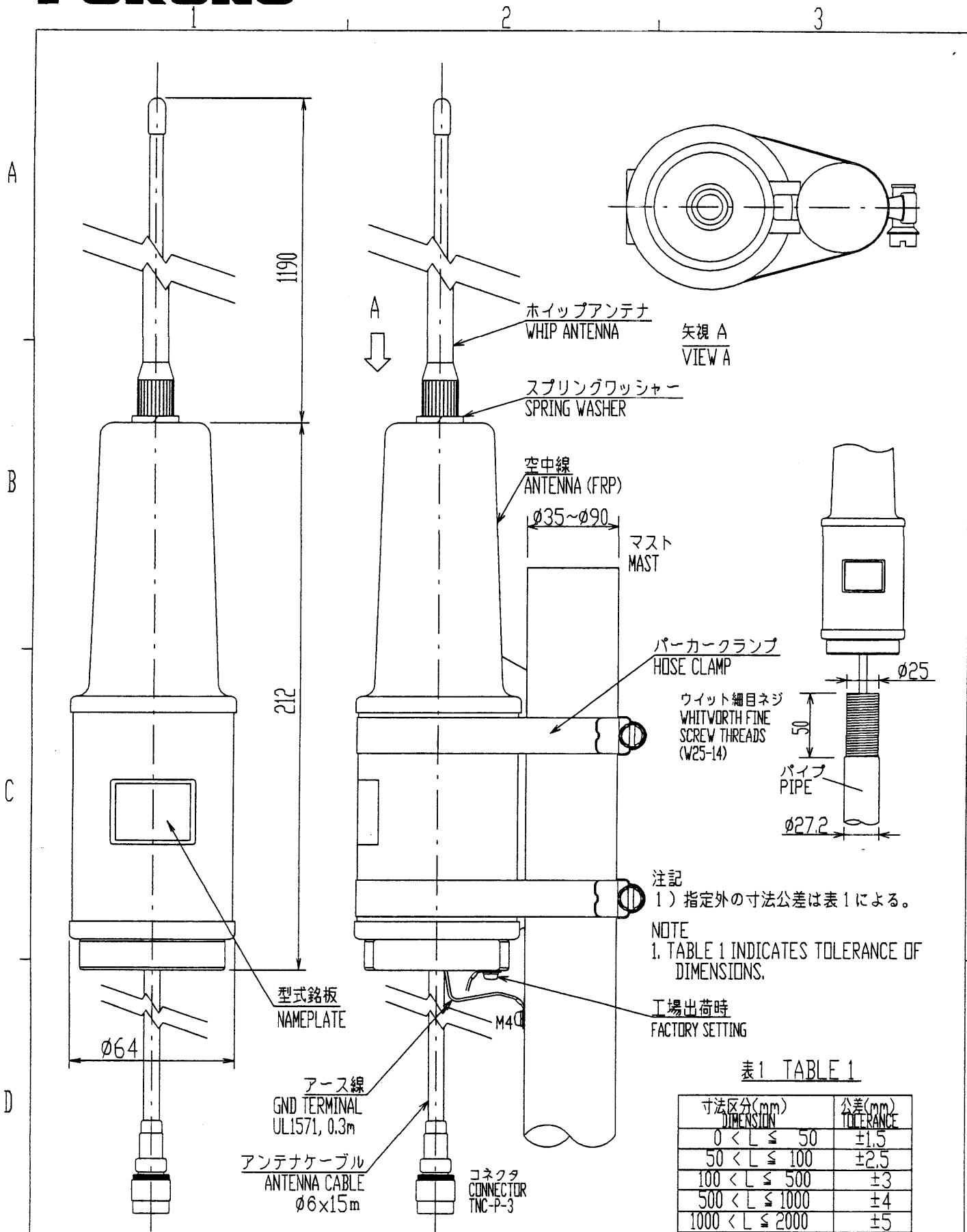

|                                    |                |                      |
|------------------------------------|----------------|----------------------|
| DRAWN<br>Oct. 1 '01<br>T. YAMASAKI |                | TYPE<br>GR-8         |
| CHECKED<br>Oct 3 '01 T. K.         |                | 名称<br>アンテナ部          |
| APPROVED<br>Oct 3 '01 Y. K.        |                | 外寸図                  |
| SCALE<br>1/2                       | MASS<br>0.6 kg | NAME<br>ANTENNA UNIT |
| 質量はケーブルを含まず。<br>MASS: W/O CABLE    |                | OUTLINE DRAWING      |
| DWG.No. C4019-G01-G                |                |                      |

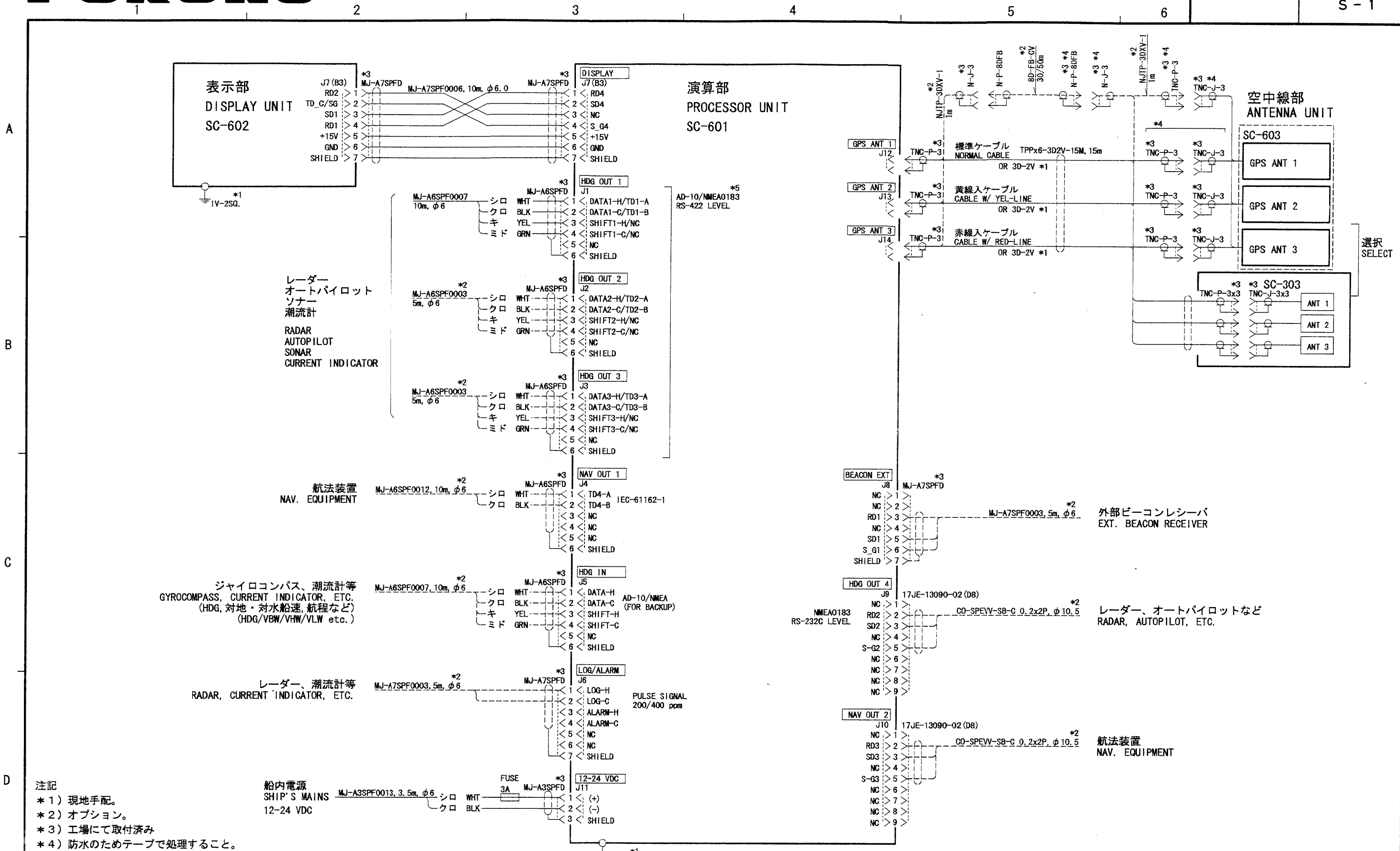

|                                  |                           |
|----------------------------------|---------------------------|
| DRAWN<br>Jan. 21 '02 T. YAMASAKI | TITLE<br>SC-60            |
| CHECKED<br>Jan 21 '02 Y. K. Ima  | 名称<br>サテライトコンパス           |
| APPROVED<br>Jan 21 '02 Y. K. Ima | 相互結線図                     |
| SCALE<br>MASS kg                 | NAME<br>SATELLITE COMPASS |
| DWG No.<br>C7248-C01- F          | INTERCONNECTION DIAGRAM   |

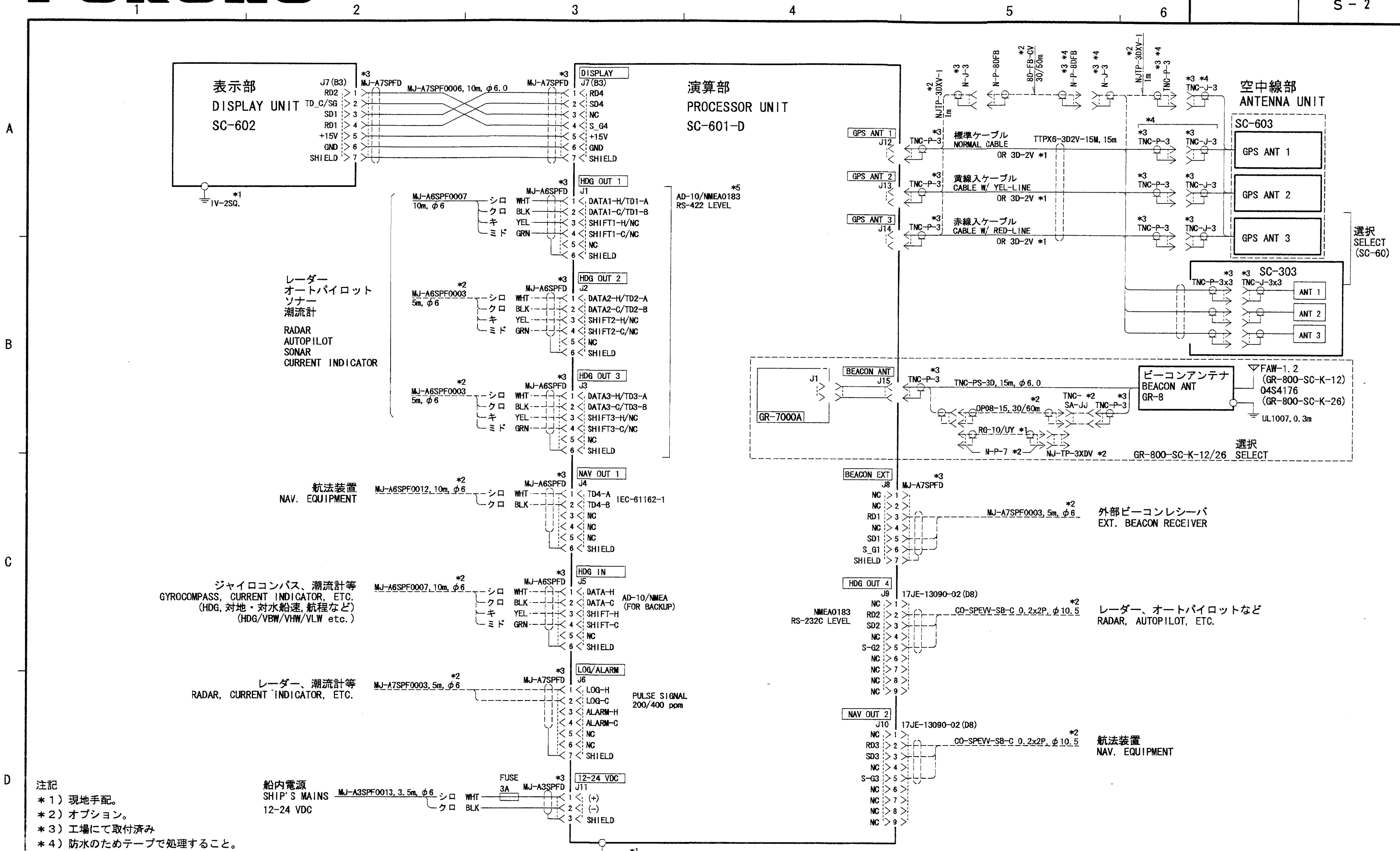

- 注記
- \*1) 現地手配。
  - \*2) オプション。
  - \*3) 工場にて取付済み
  - \*4) 防水のためテープで処理すること。
  - \*5) 内部設定切替。

- NOTE
- \*1. LOCAL SUPPLY.
  - \*2. OPTION.
  - \*3. FITTED AT FACTORY.
  - \*4. TAPE FOR WATERPROOFNESS.
  - \*5. CHANGE INNER SETTING.

|                                  |                           |
|----------------------------------|---------------------------|
| DRAWN<br>Jan. 21 '02 T. YAMASAKI | TITLE<br>SC-60 (DGPS)     |
| CHECKED<br>Jan 21 '02 Y. Kijima  | 名称<br>サテライトコンパス           |
| APPROVED<br>Jan 21 '02 Y. Kijima | 相互結線図                     |
| SCALE<br>MASS kg                 | NAME<br>SATELLITE COMPASS |
| DWG No.<br>C7248-C02-F           | INTERCONNECTION DIAGRAM   |



# INDEX

---

|  |      |
|--|------|
| <b>A</b>                                     |      |
| Alarms .....                                 | 3-5  |
| Alarms menu .....                            | 3-5  |
| <b>B</b>                                     |      |
| Battery replacement .....                    | 4-5  |
| <b>C</b>                                     |      |
| Compass display .....                        | 3-4  |
| Control description .....                    | 3-1  |
| <b>D</b>                                     |      |
| Data clearing .....                          | 4-4  |
| Demonstration mode .....                     | 3-13 |
| DGPS   |      |
| manual setup .....                           | 3-13 |
| user beacon station editing .....            | 3-16 |
| user beacon station erasing .....            | 3-17 |
| user beacon station individual erasing ..... | 3-17 |
| user beacon station programming .....        | 3-15 |
| DGPS menu .....                              | 3-13 |
| Diagnostics .....                            | 4-2  |
| DIM key .....                                | 3-2  |
| DISP key .....                               | 3-3  |
| Distance run display .....                   | 3-4  |
| Distance run resetting .....                 | 3-19 |
| <b>E</b>                                     |      |
| Error messages .....                         | 4-6  |
| <b>F</b>                                     |      |
| Fuse replacement .....                       | 4-6  |
| <b>G</b>                                     |      |
| Geodetic chart codes .....                   | A-2  |
| Geodetic data .....                          | 3-11 |
| GPS setup menu .....                         | 3-7  |
| <b>H</b>                                     |      |
| Heading display .....                        | 3-3  |
| Heading setup menu .....                     | 2-20 |
| Heading talker ID .....                      | 3-10 |
| <b>L</b>                                     |      |
| Local time .....                             | 3-12 |
| Log pulse .....                              | 3-10 |
| <b>M</b>                                     |      |
| Maintenance                                  |      |
| battery replacement .....                    | 4-5  |
| cleaning .....                               | 4-1  |
| fuse replacement .....                       | 4-6  |
| Menu tree .....                              | A-1  |
| <b>N</b>                                     |      |
| Nav data display .....                       | 3-3  |
| Nav out menu .....                           | 3-9  |
| NMEA version menu .....                      | 3-9  |
| <b>O</b>                                     |      |
| OTHERS menu .....                            | 3-18 |
| Output data setup menu .....                 | 3-8  |
| <b>P</b>                                     |      |
| Position offset .....                        | 3-7  |
| Power on/off .....                           | 3-2  |
| Program version no. ....                     | 4-4  |
| <b>R</b>                                     |      |
| Rate-of-turn display .....                   | 3-4  |
| ROT range, smoothing .....                   | 3-18 |
| <b>S</b>                                     |      |
| Satellite status .....                       | 3-6  |
| Satellites                                   |      |
| disabling .....                              | 3-7  |
| status display .....                         | 3-6  |
| SAT STATUS key .....                         | 3-1  |
| Set and drift display .....                  | 3-4  |
| Smoothing .....                              | 3-7  |
| Steering display .....                       | 3-4  |
| System configuration .....                   | v    |
| System setup menu .....                      | 3-11 |
| <b>T</b>                                     |      |
| Time format .....                            | 3-12 |
| TRIP menu .....                              | 3-19 |
| Troubleshooting .....                        | 4-2  |
| <b>U</b>                                     |      |
| Units of measurement .....                   | 3-12 |

**FURUNO****FURUNO ELECTRIC CO., LTD.**

9-52 Ashihara-Cho, Nishinomiya City, 662-8580, Hyogo, Japan

Tel: +81 798-65-2111 Fax: +81 798-65-4200

Pub NO. DOC-376

**Declaration of Conformity**We **FURUNO ELECTRIC CO., LTD.**-----  
(Manufacturer)

9-52 Ashihara-Cho, Nishinomiya City, 662-8580, Hyogo, Japan

-----  
(Address)

declare under our sole responsibility that the product

Satellite compass Model SC-60

(Serial No. 3452-0001)

-----  
(Model name, serial number)

is in conformity with the essential requirements as described in the Directive 1999/5/EC of the European Parliament and of the Council of 9 March 1999 on radio equipment and telecommunications terminal equipment (R&TTE Directive) and satisfies all the technical regulations applicable to the product within this Directive

EN 60945: 1997-01 (IEC 60945 Third edition: 1996-11)

-----  
(title and/or number and date of issue of the standard(s) or other normative document(s))

For assessment, see

- Statement of Opinion N° 01214074/AA/00 of 20 April 2001 issued by KTL Certification, The Netherlands
- Test report FLI 12-01-014 of 6 February 2001 prepared by Furuno Labotech International Co., Ltd.

On behalf of Furuno Electric Co., Ltd.

Hiroaki Komatsu  
Manager,  
International Rules and RegulationsNishinomiya City, Japan  
May 16, 2001-----  
(Place and date of issue)-----  
(name and signature or equivalent marking of authorized person)