



MADI INTERFACE CARD MY16-MD64

OWNER'S MANUAL
BEDIENUNGSANLEITUNG
MODE D'EMPLOI
MANUAL DE INSTRUCCIONES
MANUALE DI ISTRUZIONI
使用说明书
取扱説明書

ENGLISH

DEUTSCH

FRANÇAIS

ESPAÑOL

ITALIANO

中文

日本語

EN
DE
FR
ES
IT
ZH
JA

FCC INFORMATION (U.S.A.)

1. IMPORTANT NOTICE: DO NOT MODIFY THIS UNIT!

This product, when installed as indicated in the instructions contained in this manual, meets FCC requirements. Modifications not expressly approved by Yamaha may void your authority, granted by the FCC, to use the product.

2. IMPORTANT:

When connecting this product to accessories and/or another product use only high quality shielded cables. Cable/s supplied with this product MUST be used. Follow all installation instructions. Failure to follow instructions could void your FCC authorization to use this product in the USA.

3. NOTE:

This product has been tested and found to comply with the requirements listed in FCC Regulations, Part 15 for Class "B" digital devices. Compliance with these requirements provides a reasonable level of assurance that your use of this product in a residential environment will not result in harmful interference with other electronic devices. This equipment generates/uses radio frequencies and, if not installed and used according to the instructions found in the users manual, may cause interference harmful to the operation of other electronic devices. Compliance with FCC regulations does

not guarantee that interference will not occur in all installations. If this product is found to be the source of interference, which can be determined by turning the unit "OFF" and "ON", please try to eliminate the problem by using one of the following measures:

Relocate either this product or the device that is being affected by the interference.

Utilize power outlets that are on different branch (circuit breaker or fuse) circuits or install AC line filter/s.

In the case of radio or TV interference, relocate/reorient the antenna. If the antenna lead-in is 300 ohm ribbon lead, change the lead-in to co-axial type cable.

If these corrective measures do not produce satisfactory results, please contact the local retailer authorized to distribute this type of product. If you can not locate the appropriate retailer, please contact Yamaha Corporation of America, Electronic Service Division, 6600 Orangethorpe Ave, Buena Park, CA90620

The above statements apply ONLY to those products distributed by Yamaha Corporation of America or its subsidiaries.

* This applies only to products distributed by YAMAHA CORPORATION OF AMERICA.

(class B)

This device complies with Part 15 of the FCC Rules. Operation is subject to the following two conditions: (1) this device may not cause harmful interference, and (2) this device must accept any interference received, including interference that may cause undesired operation.

CANADA

This Class B digital apparatus complies with Canadian ICES-003.

Cet appareil numérique de la classe B est conforme à la norme NMB-003 du Canada.

- This applies only to products distributed by Yamaha Canada Music Ltd. (class B)
- Ceci ne s'applique qu'aux produits distribués par Yamaha Canada Musique Ltée.

PRECAUTIONS

PLEASE READ CAREFULLY BEFORE PROCEEDING

* Please keep this manual in a safe place for future reference.



WARNING

Always follow the basic precautions listed below to avoid the possibility of serious injury or even death from electrical shock, short-circuiting, damages, fire or other hazards. These precautions include, but are not limited to, the following:

- Before installing the card in an audio device please check to make sure that the device is compatible with the card and check possible restrictions regarding the maximum number of Yamaha and third-party expansion cards that can be simultaneously installed. Refer to the owner's manual supplied with the audio device, and/or the Yamaha Pro Audio web site at: <http://www.yamahaproaudio.com/>
- Do not install the card in any Yamaha products not specified by Yamaha for use with the card to avoid possible electrical shock, fire, or equipment damage.
- Do not attempt to disassemble or modify the card. Do not apply excessive force to card connectors or other card components. Mishandling of the card may lead to shock, fire hazard, or equipment failure.
- Be sure to disconnect the power cable of the host device before installing the card and connecting/disconnecting the cables (in order to eliminate shock hazard, undesired noise, and avoid equipment damage).
- Turn off all peripheral devices connected to the host device before installation, and unplug all related cables.



To customers using an MY16-EX card

Be sure to turn off host devices BEFORE plugging or unplugging the Ethernet cable that connects to an MY16-EX card. Plugging or unplugging the cables while power to the devices is on may result in serious noise.



CAUTION

Always follow the basic precautions listed below to avoid the possibility of physical injury to you or others, or damage to the device or other property. These precautions include, but are not limited to, the following:

- Be sure to properly ground the host device to prevent electrical shock and/or malfunction.
- Do not touch the metallic leads (pins) of the circuit board when handling the card. The pins are sharp and may cause hand cuts.
- Wear a pair of heavy gloves during installation to avoid scratching or cutting your hands on sharp edges.
- Avoid touching exposed connectors and metal parts to minimize the possibility of bad connections.
- Drain all static electricity from your clothing and body before handling the card. Static electricity can damage the card. Touch an exposed metal part of the host device or other grounded object beforehand.
- Do not drop the card or subject it to physical shock as this can result in breakage and/or malfunction.
- Do not drop screws or other small parts inside the card. If power is applied while screws or similar metal objects are loose inside the unit the card may malfunction or be damaged. If you cannot retrieve dropped objects yourself, refer the problem to qualified Yamaha service personnel.

Yamaha cannot be held responsible for damage caused by improper use or modifications to the device, or data that is lost or destroyed.

- The illustrations as shown in this manual are for instructional purposes only, and may be different from the ones on your equipment.
- Ethernet is a trademark of Xerox Corporation.
- The company names and product names in this manual are the trademarks or registered trademarks of their respective companies.

Introduction

Thank you for purchasing the Yamaha MY16-MD64 MADI interface card. The MY16-MD64 is a MADI card for use with compatible Yamaha professional audio equipment. Using the MY16-MD64 with a maximum of three MY16-EX Yamaha I/O expansion cards allows transmission and reception of up to 64 channels (in/out) of uncompressed digital audio signals when running at a sampling frequency of 48 kHz or 44.1 kHz.

About the host devices in which the MY16-MD64 can be installed

Before installing the card in a host device, please refer to the Yamaha Pro Audio web site for the latest information on the compatible host devices in which the card can be installed.

Yamaha Pro Audio web site:

<http://www.yamahaproaudio.com/>

About the MADI channel number

Ch1-16 will be assigned to the MY16-MD64. Ch17-32, Ch33-48 and Ch49-64 will be assigned to the MY16-EX in the order of connection.

Installation information

Please refer to the owner's manual supplied with the host device for installation information.

As well as securing the card in place, the fixing screws at the left and right of the card function as electrical grounds. Be sure to screw them in tightly.

Accessories

Owner's Manual

Part Names and Functions

■ Panel

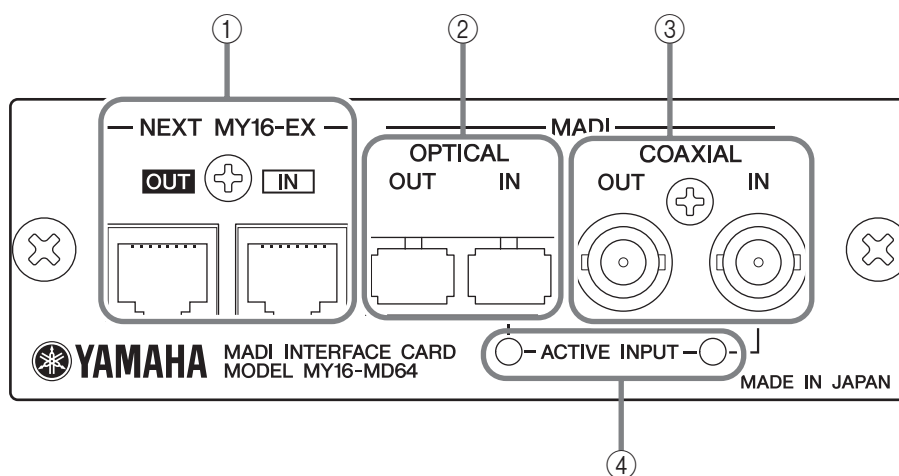

① [NEXT MY16-EX IN][NEXT MY16-EX OUT] Connectors

These RJ-45 connectors can be connected via an Ethernet straight cable (CAT5e or higher category) to the [MASTER SIDE IN] or [MASTER SIDE OUT] connector of the Yamaha MY16-EX I/O expansion card for transmission and reception of the audio and word clock signals.

NOTE:

Use an STP (Shielded Twisted Pair) cable to prevent electromagnetic interference. Using a UTP (Unshielded Twisted Pair) cable may cause noise or cut off sound. Also, be sure to attach the ferrite core included with the MY16-EX to a location close to the cable plug connected to the [NEXT MY16-EX OUT] connector.

② [OPTICAL IN][OPTICAL OUT] Connectors

These are SC connectors that can be connected via a multimode fiber optic cable to other MADI devices for transmission and reception of audio and control signals.

NOTE:

About the cable

- Use a multimode fiber optic cable with 50-micron core/125-micron cladding diameters, or 62.5-micron core/125-micron cladding diameters.
- Cables up to 2,000 meters in length can be used.

About the connector

- Use SC duplex connectors.
- Attach the supplied rubber cap to the connectors on the card to prevent dust from settling on the connectors when the cable is not connected.

③ [COAXIAL IN][COAXIAL OUT] Connectors

These are BNC connectors that can be connected via a 75 ohm coaxial cable to other MADI devices for transmission and reception of the audio and control signals.

NOTE:

Cables up to 100 meters in length can be used.

④ ACTIVE INPUT Indicators

The indicator at the [OPTICAL IN] or [COAXIAL IN] connector that receives the available signals blinks green.

NOTE:

The indicator does not blink if the settings for the MADI channel mode and sampling frequency of the received signals and those for SW1/SW2 differ. Set these switches before you use the card.

Redundant OPTICAL/COAXIAL inputs

If the card receives a signal available for both the [OPTICAL IN] connector and the [COAXIAL IN] connector, the OPTICAL signal will take priority. Also, if the OPTICAL signal encounters technical difficulty (such as a disconnection of the fiber optic cable), the input signal automatically switches to the COAXIAL signal, enabling the card to take advantage of its redundant inputs. However, the sound is cut off when automatically switched.

Serial communication between Yamaha devices

You can control the internal head amplifiers of a Yamaha digital mixing engine DME24N from a Yamaha digital mixing console LS9 by installing the card in each device.

Firmware version 3.04 or higher is required for the DME24N. You can download the most recent firmware from the following Yamaha web site.

<http://www.yamahaproaudio.com/>

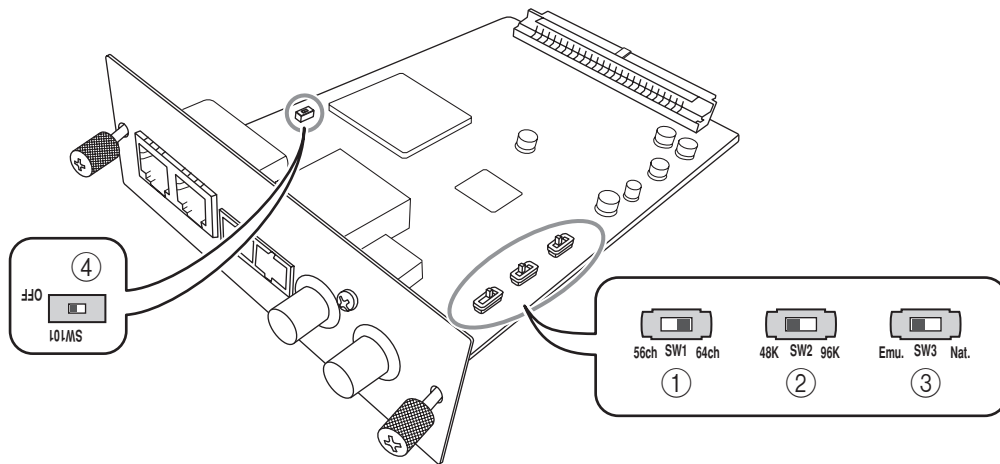
Switches

Set these switches as appropriate for your situation and for the device in which the card is installed.

① MADI Channel Mode (SW1)

Mode Position	Position
56 channel	56ch
64 channel	64ch

NOTE:

The 56-channel mode conforms to AES10-1991. The 64-channel mode conforms to AES10-2003.

② Sampling Frequency (SW2)

Mode Position	Position
44.1/48 kHz	48K
88.2/96 kHz	96K

NOTE:

This card supports only Double Speed mode when running at 88.2/96kHz. (Double Channel mode is not supported.)

③ Card ID (SW3)

Mode Position	Position
Emulation	Emu.
Native	Nat.

Typically set this switch to the [Emu.] position. If you set this switch to the [Emu.] position and switch ② (SW2) to the [48K] position, the host device will recognize the card as a Yamaha MY16-AT digital I/O card. If you set this switch to the [Emu.] position and switch ② (SW2) to the [96K] position, the host device will recognize the card as a Yamaha MY8-AE96 digital I/O card. If you use the card in a coming host device that supports the Native mode, setting this switch to the [Nat.] position enables you to make best use of the MY16-MD64 function.

④ SW101

Leave this switch permanently set to the [OFF] position during use. Please do not change this setting. Otherwise the card will not operate properly.

Connection Example

ENGLISH

DEUTSCH

FRANÇAIS

ESPAÑOL

ITALIANO

中文

日本語

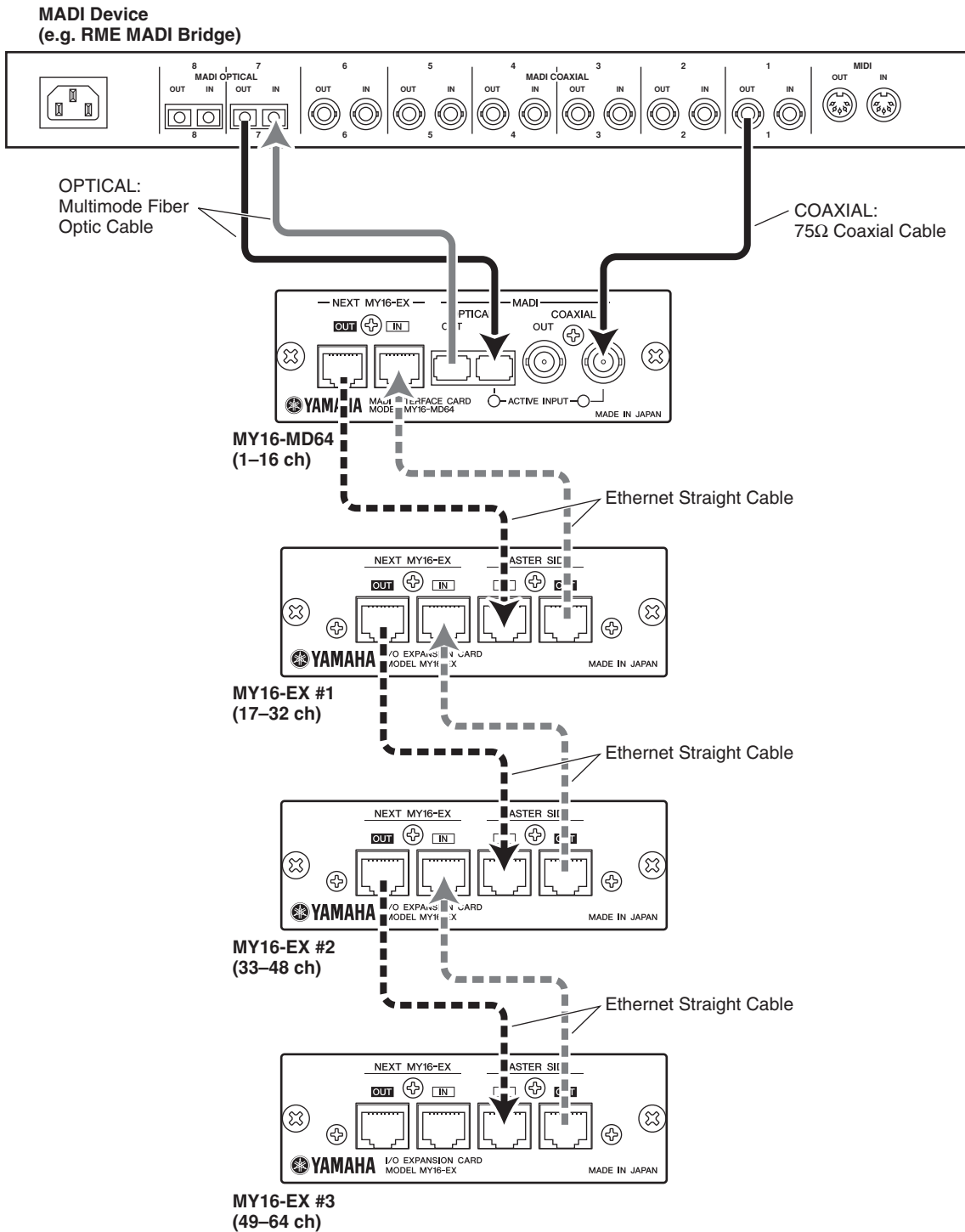

Appendix

Dimensions

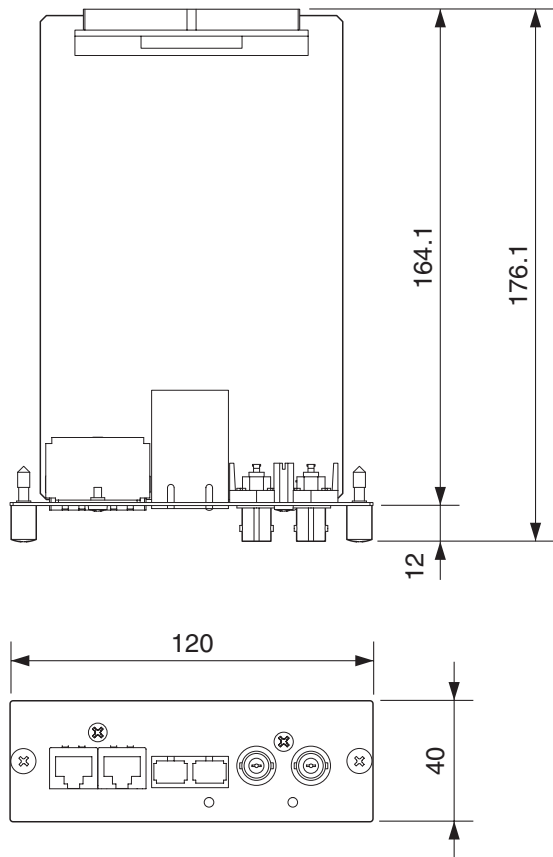

Unit: mm

- * Specifications and descriptions in this owner's manual are for information purposes only. Yamaha Corp. reserves the right to change or modify products or specifications at any time without prior notice. Since specifications, equipment or options may not be the same in every locale, please check with your Yamaha dealer.
- * Die technischen Daten und Beschreibungen in dieser Bedienungsanleitung dienen nur der Information. Yamaha Corp. behält sich das Recht vor, Produkte oder deren technische Daten jederzeit ohne vorherige Ankündigung zu verändern oder zu modifizieren. Da die technischen Daten, das Gerät selbst oder Sonderzubehör nicht in jedem Land gleich sind, setzen Sie sich im Zweifel bitte mit Ihrem Yamaha-Händler in Verbindung.
- * Les caractéristiques techniques et les descriptions du mode d'emploi ne sont données que pour information. Yamaha Corp. se réserve le droit de changer ou modifier les produits et leurs caractéristiques techniques à tout moment sans aucun avis. Du fait que les caractéristiques techniques, les équipements et les options peuvent différer d'un pays à l'autre, adressez-vous au distributeur Yamaha le plus proche.

- * Las especificaciones y descripciones de este manual del propietario tienen sólo el propósito de servir como información. Yamaha Corp. se reserva el derecho a efectuar cambios o modificaciones en los productos o especificaciones en cualquier momento sin previo aviso. Puesto que las especificaciones, equipos u opciones pueden no ser las mismas en todos los mercados, solicite información a su distribuidor Yamaha.
- * Le specifiche e le descrizioni presenti in questo manuale sono fornite a fini puramente informativi. Yamaha Corp. si riserva il diritto di modificare prodotti o specifiche in qualsiasi momento senza preavviso. Dato che le specifiche, le apparecchiature o le opzioni possono essere diverse da paese a paese, verificarle con il proprio rappresentante Yamaha.
- * 本使用说明书中的技术规格及介绍仅供参考。YAMAHA 公司保留随时更改或修订产品或技术规格的权利，若确有更改，恕不事先通知。技术规格、设备或选购件在各个地区可能均会有所不同，因此如有问题，请和当地 YAMAHA 经销商确认。
- * 仕様および外観は改良のため、予告なく変更することがあります。

European models

Purchaser/User Information specified in EN55103-1 and EN55103-2.

Conforms to Environments: E1, E2, E3 and E4

Europäische Modelle

Käufer/Benutzerinformationen nach EN55103-1 und EN55103-2.

Entspricht den Umgebungen: E1, E2, E3 und E4

Pour les modèles distribués en Europe

Les informations d'achat/utilisation sont décrites dans les documents EN55103-1 et EN55103-2.

Conformité aux normes environnementales : E1, E2, E3 et E4

Modelos europeos

Información comprador/usuario especificada en EN55103-1 y EN55103-2.

Conforme para entornos: E1, E2, E3 y E4

Modelli europei

Informazioni acquirente/utente specificate in EN55103-1 e EN55103-2.

Conforme agli ambienti: E1, E2, E3 e E4

ENGLISH

DEUTSCH

FRANÇAIS

ESPAÑOL

ITALIANO

中文

日本語

NORTH AMERICA

CANADA

Yamaha Canada Music Ltd.
135 Milner Avenue, Scarborough, Ontario,
M1S 3R1, Canada
Tel: 416-298-1311

U.S.A.

Yamaha Corporation of America
6600 Orangethorpe Ave., Buena Park, Calif. 90620,
U.S.A.
Tel: 714-522-9011

CENTRAL & SOUTH AMERICA

MEXICO

Yamaha de México S.A. de C.V.
Calz. Javier Rojo Gómez #1149,
Col. Guadalupe del Moral
C.P. 09300, México, D.F., México
Tel: 55-5804-0600

BRAZIL

Yamaha Musical do Brasil Ltda.
Rua Joaquim Floriano, 913 - 4º andar, Itaim Bibi,
CEP 04534-013 Sao Paulo, SP. BRAZIL
Tel: 011-3704-1377

ARGENTINA

Yamaha Music Latin America, S.A.
Sucursal de Argentina
Olga Cossettini 1553, Piso 4 Norte
Madero Este-C1107CEK
Buenos Aires, Argentina
Tel: 011-4119-7000

PANAMA AND OTHER LATIN AMERICAN COUNTRIES/ CARIBBEAN COUNTRIES

Yamaha Music Latin America, S.A.
Torre Banco General, Piso 7, Urbanización Marbella,
Calle 47 y Aquilino de la Guardia,
Ciudad de Panamá, Panamá
Tel: +507-269-5311

EUROPE

THE UNITED KINGDOM

Yamaha Music U.K. Ltd.
Sherbourne Drive, Tilbrook, Milton Keynes,
MK7 8BL, England
Tel: 01908-366700

GERMANY

Yamaha Music Central Europe GmbH
Siemensstraße 22-34, 25462 Rellingen, Germany
Tel: 04101-3030

SWITZERLAND/LIECHTENSTEIN

Yamaha Music Central Europe GmbH,
Branch Switzerland
Seefeldstrasse 94, 8008 Zürich, Switzerland
Tel: 01-383 3990

AUSTRIA

Yamaha Music Central Europe GmbH,
Branch Austria
Schleiergasse 20, A-1100 Wien, Austria
Tel: 01-60203900

CZECH REPUBLIC/SLOVAKIA/ HUNGARY/SLOVENIA

Yamaha Music Central Europe GmbH,
Branch Austria, CEE Department
Schleiergasse 20, A-1100 Wien, Austria
Tel: 01-602039025

POLAND

Yamaha Music Central Europe GmbH
Sp.z o.o. Oddział w Polsce
ul. 17 Stycznia 56, PL-02-146 Warszawa, Poland
Tel: 022-868-07-57

THE NETHERLANDS/ BELGIUM/LUXEMBOURG

Yamaha Music Central Europe GmbH,
Branch Benelux
Clarissenhof 5-b, 4133 AB Vianen, The Netherlands
Tel: 0347-358 040

FRANCE

Yamaha Musique France
BP 70-77312 Marne-la-Vallée Cedex 2, France
Tel: 01-64-61-4000

ITALY

Yamaha Musica Italia S.P.A.
Combo Division
Viale Italia 88, 20020 Lainate (Milano), Italy
Tel: 02-935-771

SPAIN/PORTUGAL

Yamaha Música Ibérica, S.A.
Ctra. de la Coruna km. 17, 200, 28230
Las Rozas (Madrid), Spain
Tel: 91-639-8888

SWEDEN

Yamaha Scandinavia AB
J. A. Wettergrens Gata 1, Box 30053
S-400 43 Göteborg, Sweden
Tel: 031 89 34 00

DENMARK

YS Copenhagen Liaison Office
Generatorvej 6A, DK-2730 Herlev, Denmark
Tel: 44 92 49 00

NORWAY

Norsk filial av Yamaha Scandinavia AB
Grini Næringspark 1, N-1345 Østerås, Norway
Tel: 67 16 77 70

RUSSIA

Yamaha Music (Russia)
Office 4015, entrance 2, 21/5 Kuznetskii
Most street, Moscow, 107996, Russia
Tel: 495 626 0660

OTHER EUROPEAN COUNTRIES

Yamaha Music Central Europe GmbH
Siemensstraße 22-34, 25462 Rellingen, Germany
Tel: +49-4101-3030

AFRICA

Yamaha Corporation,
Asia-Pacific Music Marketing Group
Nakazawa-cho 10-1, Naka-ku, Hamamatsu,
Japan 430-8650
Tel: +81-53-460-2313

MIDDLE EAST

TURKEY/CYPRUS

Yamaha Music Central Europe GmbH
Siemensstraße 22-34, 25462 Rellingen, Germany
Tel: 04101-3030

OTHER COUNTRIES

Yamaha Music Gulf FZE
LOB 16-513, P.O.Box 17328, Jubel Ali,
Dubai, United Arab Emirates
Tel: +971-4-881-5868

ASIA

THE PEOPLE'S REPUBLIC OF CHINA

Yamaha Music & Electronics (China) Co.,Ltd.
25/F., United Plaza, 1468 Nanjing Road (West),
Jingan, Shanghai, China
Tel: 021-6247-2211

INDONESIA

PT. Yamaha Music Indonesia (Distributor)
PT. Nusantara
Gedung Yamaha Music Center, Jalan Jend. Gatot
Subroto Kav. 4, Jakarta 12930, Indonesia
Tel: 21-520-2577

KOREA

Yamaha Music Korea Ltd.
8F, 9F, Dongsung Bldg. 158-9 Samsung-Dong,
Kangnam-Gu, Seoul, Korea
Tel: 080-004-0022

MALAYSIA

Yamaha Music Malaysia, Sdn., Bhd.
Lot 8, Jalan Perbandaran, 47301 Kelana Jaya,
Petaling Jaya, Selangor, Malaysia
Tel: 3-78030900

SINGAPORE

Yamaha Music Asia Pte., Ltd.
#03-11 A-Z Building
140 Paya Lebar Road, Singapore 409015
Tel: 747-4374

TAIWAN

Yamaha KHS Music Co., Ltd.
3F, #6, Sec.2, Nan Jing E. Rd. Taipei.
Taiwan 104, R.O.C.
Tel: 02-2511-8688

THAILAND

Siam Music Yamaha Co., Ltd.
891/1 Siam Motors Building, 15-16 floor
Rama 1 road, Wangmai, Pathumwan
Bangkok 10330, Thailand
Tel: 02-215-2626

OTHER ASIAN COUNTRIES

Yamaha Corporation,
Asia-Pacific Music Marketing Group
Nakazawa-cho 10-1, Naka-ku, Hamamatsu,
Japan 430-8650
Tel: +81-53-460-2317

OCEANIA

AUSTRALIA

Yamaha Music Australia Pty. Ltd.
Level 1, 99 Queensbridge Street, Southbank,
Victoria 3006, Australia
Tel: 3-9693-5111

COUNTRIES AND TRUST TERRITORIES IN PACIFIC OCEAN

Yamaha Corporation,
Asia-Pacific Music Marketing Group
Nakazawa-cho 10-1, Naka-ku, Hamamatsu,
Japan 430-8650
Tel: +81-53-460-2313

HEAD OFFICE Yamaha Corporation, Pro Audio & Digital Musical Instrument Division
Nakazawa-cho 10-1, Naka-ku, Hamamatsu, Japan 430-8650
Tel: +81-53-460-2441