

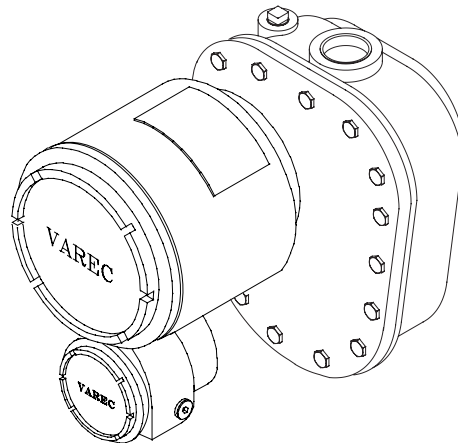

4000 Tank Gauge Transmitter

Advanced Technology Transmitter for transmission of level and temperature data from the tankside to inventory management systems.

Installation and Operations Manual



www.varec.com

Copyright

All rights reserved. Printed in the United States of America. Except as permitted under the United States Copyright Act of 1976, no part of this publication may be reproduced, stored in a retrieval system or transmitted in any form or by any means— electronic, mechanical, photocopying, recording or otherwise— without the prior written permission of the Publisher:

Varec, Inc.
5834 Peachtree Corners East
Norcross (Atlanta) GA 30096
USA

Trademarks acknowledged

Varec, Inc. recognizes all other trademarks. Trademarks of other products mentioned in this document are held by the companies producing them.

Varec® is a registered trademark of Varec, Inc. Copyright 2003

FuelsManager® is a registered trademark of Varec, Inc. Copyright 2004

MODBUS® is a registered trademark of Modicon, Inc.

TIWAY® is a registered trademark of Texas Instruments Corporation.

HART® interface is a registered trademark of HART communications foundation.

Rosemount® and Smart Family® are registered trademarks, and HART is a trademark of Rosemount Inc.

Disclaimer of Warranties

The contract between the Seller and the Buyer states the entire obligation of the Seller. The contents of this document shall not become part of or modify any prior or existing agreement, commitment or relationship between the Seller and Buyer. There are no express or implied warranties set out in this document. The only warranties that apply are those in the existing contract between the Seller and Buyer.

Varec, Inc. products have not been tested by Varec, Inc. under all possible operational conditions, and Varec, Inc. may not have all the data relative to your application. The information in this document is not all inclusive and does not and cannot take into account all unique situations. Consequently, the user should review this product literature in view of his/her application. If you have any further questions, please contact Varec, Inc. for assistance.

Limitations of Seller's Liability

In the event that a court holds that this document created some new warranties, Seller's liability shall be limited to repair or replacement under the standard warranty clause. In no case shall the Seller's liability exceed that stated as Limitations of Remedy in the contract between the Seller and Buyer.

Terms of Use

The information provided in this document is provided "as is" without warranty of any kind. Varec, Inc. disclaim all warranties, either express or implied, including the warranties of merchantability and fitness for a particular purpose. In no event shall Varec, Inc. or its suppliers be liable for any damages whatsoever including direct, indirect, incidental, consequential, loss of business profits or special damages, even if Varec, Inc. or its suppliers have been advised of the possibility of such damages.

Use of parts that are not manufactured or supplied by Varec, Inc. voids any Varec, Inc. warranty and relieves Varec, Inc. of any obligation to service the product under warranty. Varec, Inc. recommends the use of only Varec, Inc. manufactured or supplied parts to maintain or service Varec, Inc. products.

Safety Precaution Definitions

Caution! Damage to equipment may result if this precaution is disregarded.

Warning! Direct injury to personnel or damage to equipment which can cause injury to personnel may result if this precaution is not followed.

Safety Precautions

READ AND UNDERSTAND THIS INSTRUCTION MANUAL BEFORE INSTALLING, OPERATING OR PERFORMING MAINTENANCE ON VAREC 4000 SERIES TANK GAUGE TRANSMITTER. FOLLOW ALL PRECAUTIONS AND WARNINGS NOTED HEREIN WHEN INSTALLING, OPERATING OR PERFORMING MAINTENANCE ON THIS EQUIPMENT.

1	Introduction	1
1.1	Using This Manual	1
1.2	Getting Acquainted with the Advanced Technology Transmitter (ATT)	1
1.4	Configuration	2
1.5	Construction	2
2	Installation	3
2.1	Overview	3
2.1.1	Unpacking	3
2.1.2	Storage Prior to Installation	3
2.1.3	Becoming Familiar with the ATT	3
2.1.4	Hardware Configuration	3
2.3	Grounding the Equipment	5
2.4	Wiring	5
2.4.1	ATT Wiring	5
2.4.2	Wiring Preparation	5
2.4.3	Connecting Input Power	5
2.4.4	Connecting Host Communication	6
2.5.1	Connecting the Handheld Terminal	10
2.5.2	Wiring Completion	10
2.5.3	Installation Checkout	10
2.5.4	Installation Checklist	10
3	Configuration	11
3.1	Configuration Parameters	11
3.2	1200 Hand Held Terminal	11
3.3	Terminal Mode Operation	13
3.4.5	Notes on Menu Items	18
3.5	Quick Setup	19
3.5.6	Imperial Decimal 1800 Series Transmitter Quick Setup	24
3.5.7	0-20 Meters 1800 Series Transmitter Quick Setup	24
3.5.8	0-30 Meters 1800 Series Transmitter Quick Setup	24
4	Maintenance and Troubleshooting	27
4.1	Maintenance	27
4.2	Battery Replacement	27
4.3.1	ATT Error Status Conditions	28
4.5	ATT Configuration Error Checking	29
4.7	Host Communication Loopback Tests	30
5	Specifications	31
5.1	Specifications and Physical Characteristics	31

5.1.1	Environmental	31
5.1.2	Physical	31
5.1.3	Input Power	31
5.1.4	Level Measurement	32
5.2.1	Explosion Proof	33
5.2.2	Intrinsic Safety	33
6	Order Codes	35
7	Theory of Operation	37
7.1	Overview	37
7.2	CPU Board	37
7.3	Status Inputs and Outputs	38
7.4	ATTI Communications Port	38
7.5	Host Communications Interfaces	38
7.6	Level Measurement	38
7.6.1	Back-up Battery	38
7.6.2	Damping	38
7.7	Encoder Battery Backup	39
7.8	Temperature Measurement	39
7.9	Host Communication	39
7.10	Mark/Space Host Interface	40
7.11	Modbus Support over Mark/Space Host Interface	41
7.12	Compatibility with Varec Tank Polling Unit	41
8	ATT Family of Products	43
8.1	Model 4040 Display Unit	43
8.2	Model 4050 Digital Input/Output Unit	44
8.2.1	Digital Outputs	44
8.2.2	Digital Inputs	44
8.2.3	Relay Specifications	44
9	Modbus Implementation	45
9.1	Introduction	45
9.2	Implementation	45
9.3	Configuration	45
9.5	Integer Registers	47
9.5.1	Integer Data	48
9.5.3	Character Data	49
9.5.5	Packed Bit Data	50
9.6.1	Floating-Point Data	51
9.6.2	The Two 16-bit Registers Format	51

9.6.3	Floating Point Data	.51
9.6.5	Floating Point Data	.52
9.6.6	Floating Point Data	.52
9.7.1	Status Bit Data	.53
9.8	Exception Responses	.53
9.10	Loopback Test	.54
9.11	Hardware Implementation	.54
9.12	Integer Register Map	.55
9.14	Status Bit Register Map	.59
10	Optional Interfaces	.61
10.1	4000TIFMO	.61
10.2	4000GEFMO	.61
10.3	4000LJFMO	.61
10.4	4000MXFMO	.61
10.6	4000GMFMO	.62
Glossary		.63

1 Introduction

1.1 Using This Manual

This manual is designed to assist the user with the installation, configuration, operation, maintenance, and troubleshooting of the Varec Model 4000 Advanced Technology Transmitter (ATT).

1.2 Getting Acquainted with the Advanced Technology Transmitter (ATT)

The Varec Model 4000 Advanced Technology Transmitter (ATT), in conjunction with a host, represents a data acquisition and communications system for use in liquid level measurement and/or other measurement applications. Liquid level measurement is provided by the Advanced Technology Transmitter coupled to a Varec Model 2500 or other level gauge, as shown in Figure 1-1.

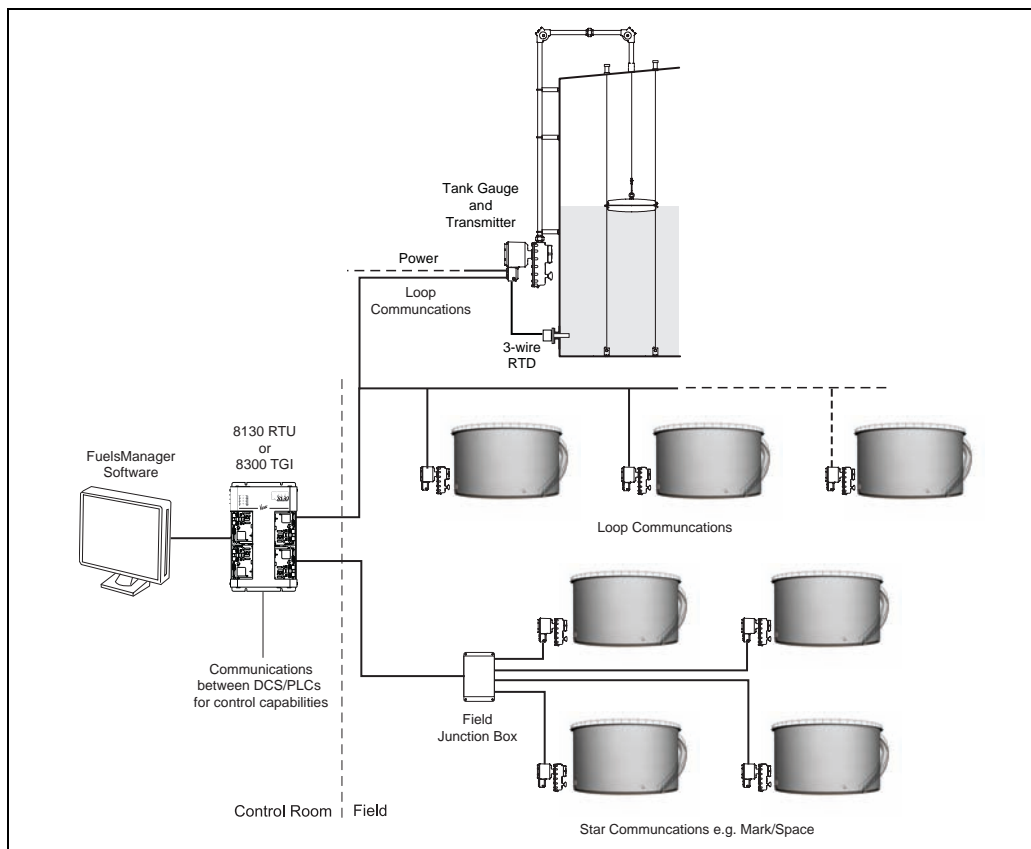

Figure 1-1: Tank Installation with Model 4000 ATT

1.3 Operation

The ATT uses an incremental counting technique for determining liquid level. An initial level is identified as part of the calibration procedure. Changes to that level are determined through incremental increases or decreases detected by the ATT.

The host computer collects measurement information by polling the Advanced Technology Transmitter over a variety of communication interfaces such as EIA485 and Mark/Space. Several communication protocols are supported. Among them are Modbus and Mark/Space.

1.4 Configuration

The Varec Model 1200 Handheld Terminal is used to configure the ATT. It connects to the same ATTI bus used to interconnect other input/output devices to the ATT. There is a special connection located inside the junction box for the Handheld Terminal.

1.5 Construction

The Advanced Technology Transmitter is housed within an aluminum enclosure. The enclosure and assembly meet explosion proof requirements and are environmentally sealed to prevent internal exposure to contamination.

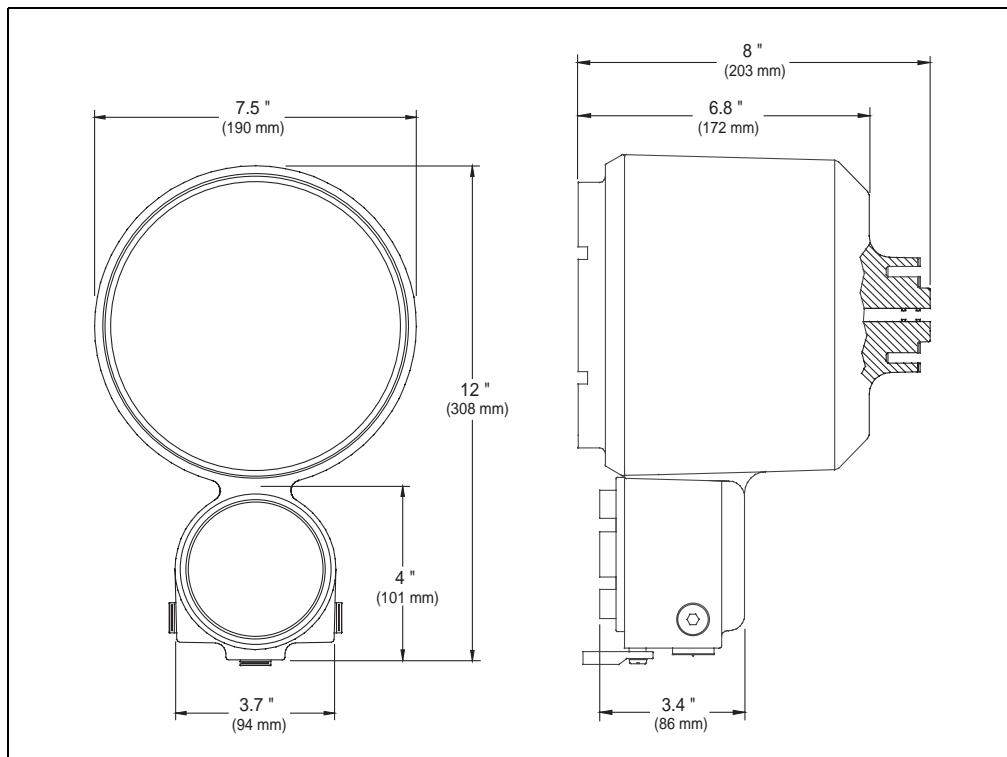

Figure 1-2: Model 4000 Advanced Technology Transmitter Assembly

2 Installation

2.1 Overview

This section contains instructions for unpacking, mounting, grounding, and wiring the Varec Model 4000 Advanced Technology Transmitter (ATT) assembly. An installation checklist is also included.

Warning! To avoid electric shock and possible injury, do not perform any service procedures other than those specified in this manual. These installation instructions are for use by qualified service technicians.

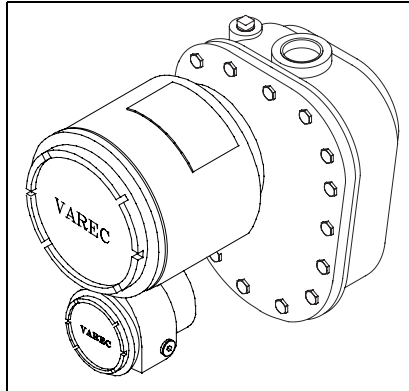

Figure 2-1: Model 4000 ATT mounted on Model 2500 ATG

2.1.1 Unpacking

Remove the ATT from the shipping container and inspect it for evidence of shipping or handling damage. Report any shipping damage to the carrier. Verify that the contents of the shipping container agrees with the packing list.

2.1.2 Storage Prior to Installation

If the ATT is to be stored prior to installation, it should be repackaged in its shipping container and stored in a temperature and humidity controlled environment.

2.1.3 Becoming Familiar with the ATT

The ATT is housed within an explosion proof enclosure. A cover is provided to permit access to both the electronics and backup batteries.

3/4- and 2 1/2-inch NPT plugs are provided for wiring access. Wiring to the ATT consists of connecting power, host communication, RTD input and an optional ground connection.

2.1.4 Hardware Configuration

All configuration is performed using the Model 1200 Handheld Terminal or a download from a host computer. However, certain parameters such as communication address and speed must be configured via the Model 1200 Handheld Terminal.

2.2 Mounting the Equipment

The ATT is bolted to the Model 2500 Automatic Tank Gauge head as illustrated in Figure 2-2. It may also be mounted to Endress+Hauser, Sakura, Tokyo-Keiso, Shand & Jurs, and Gauging Systems, Inc. float and tape gauges with the Endress+Hauser adapter shown in the following table.

Part Number	Gauge Adapter Kit
13-05956-102	L&J (Shand & Jurs) 92513, 92514, 92020, 92030
13-05956-202	Whessoe 2006, 2026, 2036 and L&J (Shand & Jurs) 92006

Mounting the ATT to the Level Gauge is accomplished in the following manner:

1. Remove the back cover of the Level Gauge.
2. Remove the access cap from the back cover of the Level Gauge.
3. Mount the ATT in place of the access cap, making certain that the word "TOP" cast into the housing lines up with the top of the Level Gauge back cover.
4. Install the Level Gauge back cover with the transmitter in the Level Gauge. Make certain that the slot in the ATT drive coupling engages with the pin on the tape sheave of the Level Gauge.
5. Proceed with field wiring.

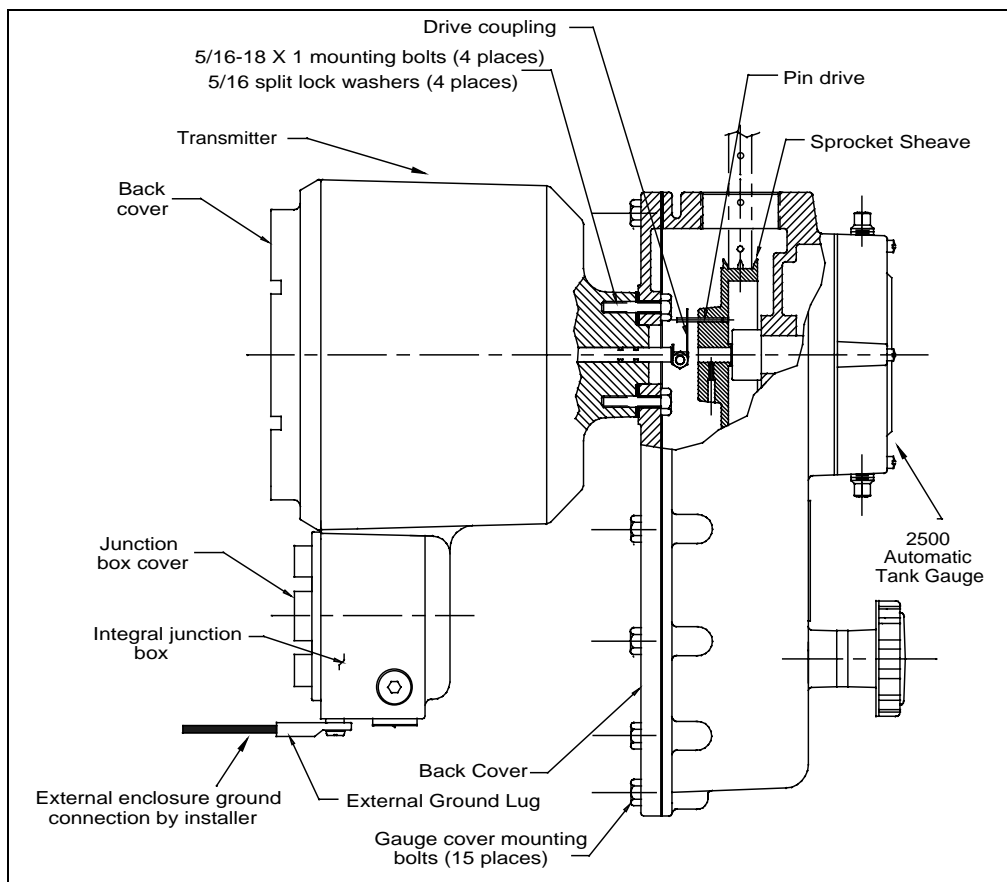

Figure 2-2: ATT Mounting Diagram

2.3 Grounding the Equipment

Warning! The ATT must be grounded before communication and power connections are made.

An external grounding lug is provided on the ATT. A connection from the ground lug to earth ground must be made before any other wiring connections are made.

Note! For adequate/proper operation of the ATT lightning arrester, a ground strap must be attached to the ATT. Grounding through mounting kits or pipe coupling is not adequate.

Note! Properly seal all ports to prevent moisture or other contamination from entering the wiring compartment.

2.4 Wiring

Connections should be made in a conventional manner according to local or plant electric codes.

Warning! Explosion-proof seals must be installed in all wiring entries. Any unused entries must be plugged with pipe plugs and secured with Loctite®, or equivalent.

2.4.1 ATT Wiring

Wiring the ATT is described in the following paragraphs. The wiring diagram provided in Figure 2-3 on page 6 should be used in conjunction with these wiring instructions.

2.4.2 Wiring Preparation

Remove the two thread protectors from the 1/2-inch NPT conduit entries at the top and bottom of the ATT. Remove the rear cover from the ATT housing.

2.4.3 Connecting Input Power

Warning! When connecting DC power leads to the ATT, make certain that power is OFF.

The ATT operates on a 24-48 volts DC power source. The input power connection to the ATT is accomplished in the following manner.

Connect the positive side of the power supply to terminal 10, B+, and the negative side to terminal 9, B-, of the terminal block assembly. See Figure 2-3 on page 6.

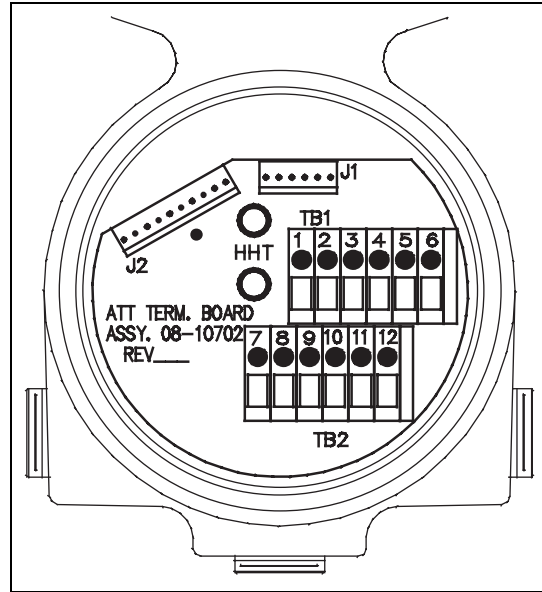

Figure 2-3: ATT Field Terminal Block Wiring

Terminal Block One TB1			Terminal Block Two TB2		
1	L+	= ATTI expansion Bus + power	12	S	= Space or EIA485 +
2	HPORT	= ATTI bus HART Signal	11	M	= Mark or EIA485 -
3	L-	= ATTI expansion Bus - power	10	B +	= ATT + power
4	C	= RTD C lead	9	B -	= ATT - power
5	B	= RTD B lead	8	--	= Reserved
6	A	= RTD A lead	7	--	= Reserved

2.4.4 Connecting Host Communication

The procedure used to wire the ATT to the host computer depends on the type of host interface option ordered with the ATT.

2.4.5 ATT EIA485 Wiring

The ATT uses a 2-wire EIA485 hardware interface to communicate with the Modbus master. EIA485 is a high speed differential communications network which allows up to 32 devices to operate on one network. The ATT and Modbus master share a twisted pair of wires to communicate. Figure 2-4 illustrates the typical EIA485 wiring.

The communication distance that EIA485 can reliably travel is dependent on baud rate (communication speed), wire quality, environmental noise, wiring configuration, and the number of multi-dropped ATTs. The recommended wire for EIA485 systems is 18-gauge or larger, shielded, twisted pairs. The shield should be earth grounded at the Modbus master (control system or computer end). The shield at the ATT should be open. The ATT B- power line acts as a common reference tie to the Modbus master. Figure 2-5 on page 8 illustrates the EIA485 Modbus system.

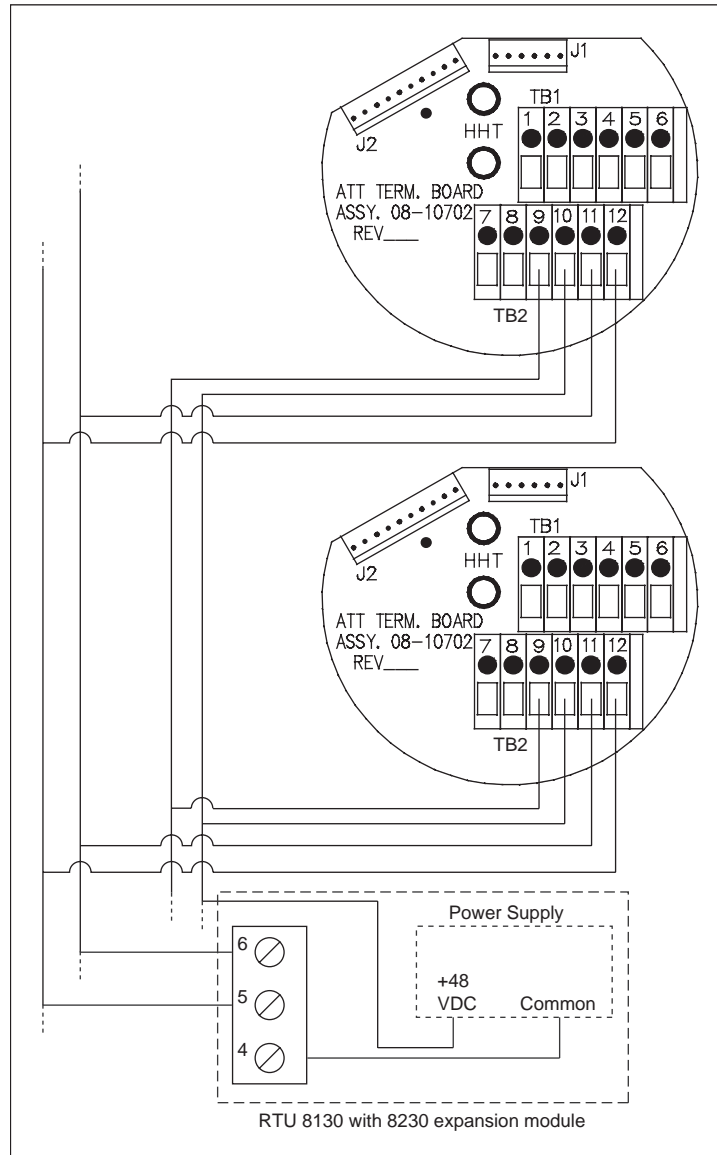

Figure 2-4: Typical EIA485 Wiring

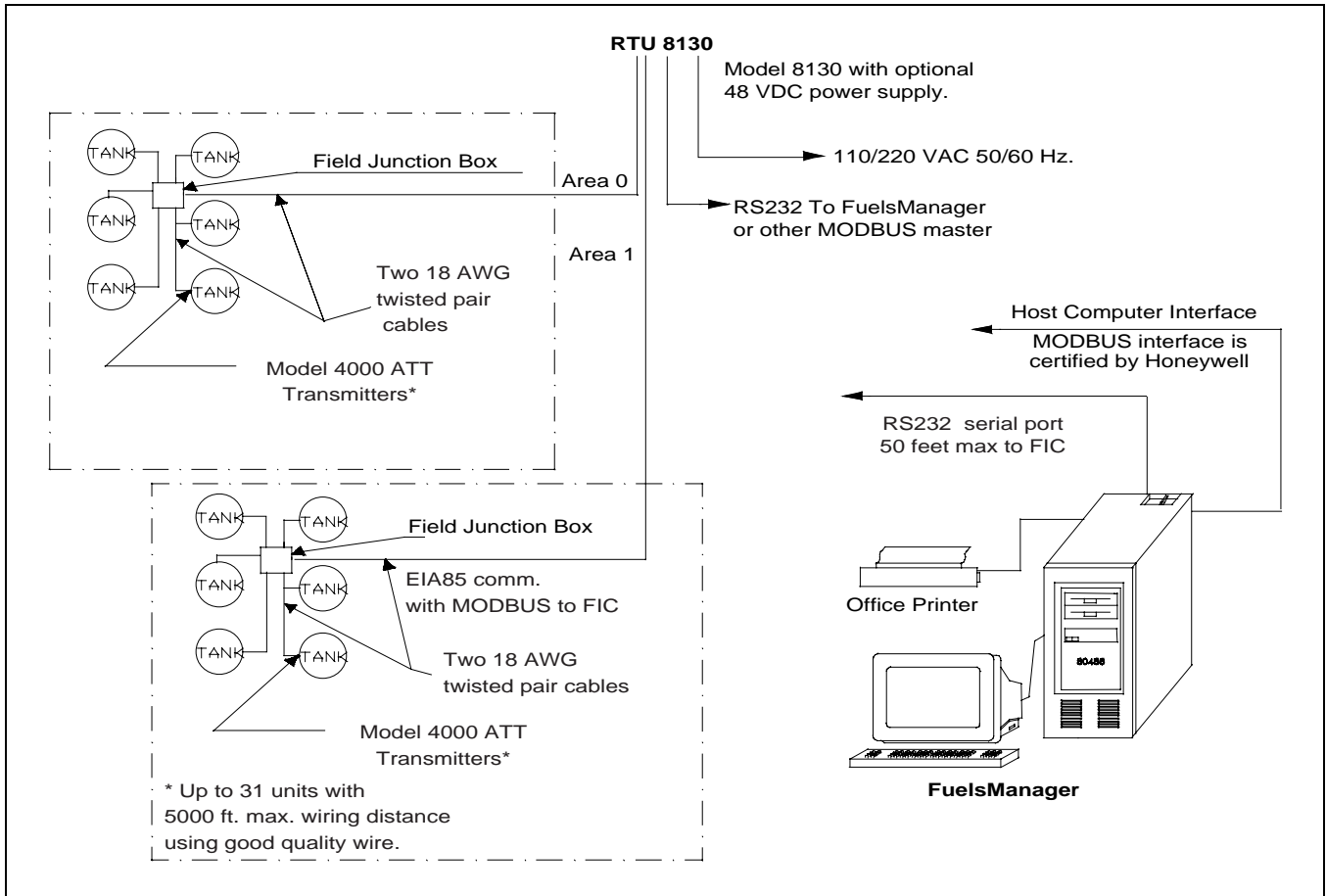

Figure 2-5: Typical EIA485 System Wiring

2.4.6 ATT Mark/Space Wiring

For an ATT using the Mark/Space field communications option, the following additional wiring connections must be made. (Refer to Input Power Wiring in Section 6 to determine the minimum wire size required.). See Figure 2-6.

- Run two twisted pairs of 18 AWG wire (Mark/Space wires) into the ATT through the conduit entry along with the 48 VDC power wiring.
- Connect the Mark line to terminal 11, M/485-, and the Space line to terminal 12, S/485+, on the terminal block assembly.

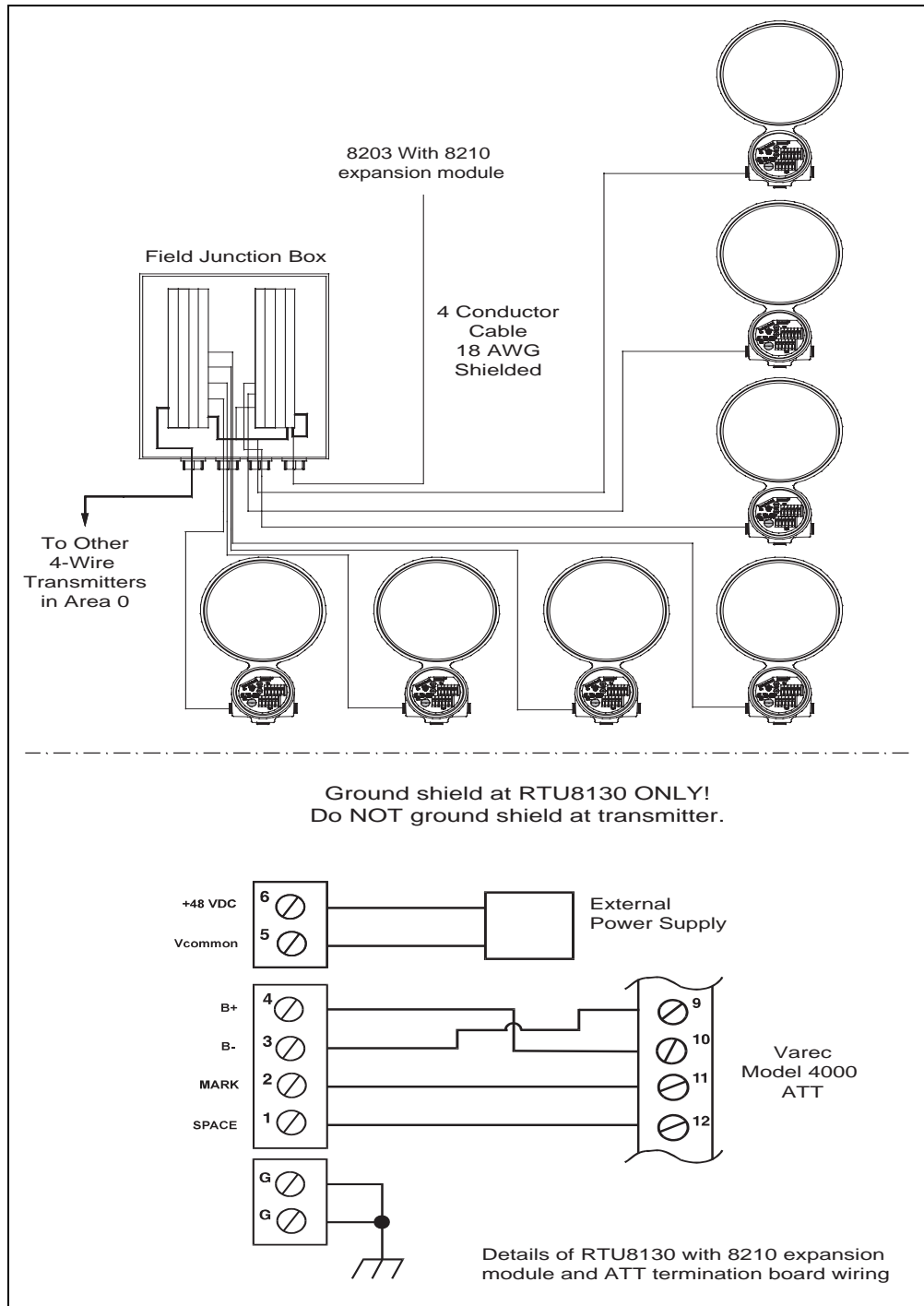

Figure 2-6: Typical Mark/Space Field Wiring

2.5 Connecting the RTD

The following list shows how the ATT is wired to an RTD device. The ATT's temperature circuit is designed to work with a platinum or copper 3-wire RTD.

2.5.1 Connecting the Handheld Terminal

Figure 2-3 on page 6 shows how the 1200 Hand Held Terminal is connected to the ATTI bus on the ATT. The Model 268 can also be used to configure the ATT.

Warning! The 1200 Hand Held Terminal on the ATT is not Intrinsically Safe. Care must be taken to only use in a non-hazardous environment

Wire as follows:

- Connect the RTD's A terminal to the ATT's terminal 6, A.
- Connect the RTD's B terminal to the ATT's terminal 5, C.
- Connect the RTD's C terminal to the ATT's terminal 4, C.

2.5.2 Wiring Completion

Caution! Do not overtighten metal plugs used to seal wiring compartment ports. Overtightening may damage the housing.

Properly seal the 1/2-inch NPT conduit entry. Install cover and tighten to ensure that the O-ring seal is adequately compressed. Proper sealing of all ports is necessary to prevent moisture or other contamination from entering the wiring compartment.

2.5.3 Installation Checkout

After a thorough check that all connections are correctly made and that all covers and plugs are installed, turn on power to the ATT. Proceed to Chapter 3, Configuration.

2.5.4 Installation Checklist

The steps required in the installation process are summarized in the following checklist. Since each step is detailed specifically with accompanying notes, cautions, and warnings, be sure to refer to the sub-sections indicated for further information.

	Step	Sub-Section(s) Reference
	Unpack the ATT and check the packing list.	Unpacking
	Verify that the required input power is available.	Mounting the ATT, Wiring
	Mount the ATT.	Mounting the Equipment
	Ground the ATT.	Grounding the Equipment
	Route the conduit between the ATT and other devices and seal all ports.	Wiring Completion
	Wire the host communications.	Connecting Host Communication
	Wire the RTD	Connecting the RTD
	Wire the input power connections.	Connecting Input Power
	Apply power to the ATT.	Installation Checkout
	Wire the Model 1200 Handheld Terminal	Connecting Handheld Terminal
	Proceed to ATT configuration procedure.	ATT Configuration (Section 3)

3 Configuration

The Varec Model 4000 Advanced Technology Transmitter (ATT) must be configured for the specific tank, attached sensors, and host interface. This section provides detailed information on ATT configuration.

The ATT can be configured with a 1200 Hand Held Terminal or from a host program such as Varec TankView.

3.1 Configuration Parameters

Configuration parameters associated with ATT operation are entered and modified using the Model 1200 and can be divided into the following areas:

- General Configuration – includes units of measure, level calibration, temperature type selection, and alarm setpoints.
- Host Configuration – includes the type of host interface used, baud rate selection, and emulation modes for other level transmitters.

3.2 1200 Hand Held Terminal

The ATT can be used with a 1200 Hand Held Terminal, see Figure 3–3 on page 13. The Model 1200 provides a local terminal interface to configure the ATT and encoder at tankside. It is connected to the ATTI bus. It can be physically attached via two banana plugs located inside the terminal block housing.

The ATT uses the Model 1200 in a different mode of operation. Normally, the Model 1200 polls the ATTI BUS device, recognizes it, and goes into an internal menu system that is specifically tailored to that ATTI Bus device. The ATT however, uses the Model 1200 in what is called ASCII Terminal mode. In this mode, the Model 1200 sends keyboard activity to the ATT and displays screen information from the ATT. The ATT can not be configured with the Rosemount Model 275 Terminal.

Because of the way the ASCII Terminal mode works on the Model 1200, the ATT is unable to poll any ATTI BUS device while communicating to it. The ATT goes from an operational mode to an off–line mode. The operational mode is automatically switched to when the Model 1200 is removed from the ATTI BUS bus.

Warning! The 1200 Hand Held Terminal on the ATT is not Intrinsically Safe. Care must be taken to only use in a non-hazardous environment.

Function keys F1 through F4, defined in Figure 3–1 on page 11, are used for basic scrolling of the ATT menus and selection of configuration parameters.

Function Key	Description
HELP	Help Message
F1	Scroll Up
F2	Scroll Down
F3	Alter/Backspace
F4	Enter
Previous Function [Ú]	Return to previous menu or abort data entry

Table 3–1: Model 1200 Function Keys

Alpha and numeric information is entered from the keypad directly. Numeric data is entered using a single keystroke, while alpha information is entered with a two–key combination. The two–key combination for alpha data consists of a shift key followed by a numeric key to select the desired alpha character.

For example, to enter the alpha character "N"; first press the shift key, then press the number 4. To enter the alpha character "R"; first press the shift key, then press the number 1.

Terminal Mode Configuration

When the Model 1200 is connected to the ATTI Bus and turned on, a blank screen will appear on the Model 1200 after a self test sequence. Pressing any key will cause the following screen to appear on the Model 1200 display:

The version indicated is the software version of the ATT.

Enter a "D" (to select Display Mode entries) or an "A" (to select Alter Mode entries) and press F4 (Enter).

If the Display Mode is selected with a "D", current status and configuration data may be examined but cannot be modified. This mode is useful for verifying ATT configuration. This mode cannot be used to actively monitor ATT operation, as normal ATT operation is suspended when the Model 1200 is connected.

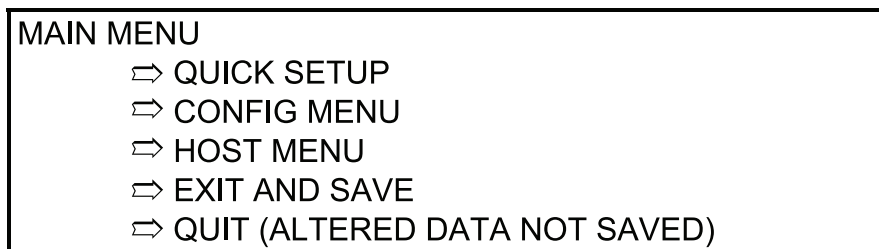

Figure 3-1: ATT Alter Mode Menu Tree

If the Alter Mode is selected with an "A", all applicable configuration parameters can be modified. Figure 3-2 on page 12 illustrates the display mode menu tree and Figure 3-1 on page 12 illustrates the Alter Mode menu tree. The menu tree groups related items under separate menus and sub-menus. The menu grouping is provided to permit the field operator to configure and display items in a related and logical order. Once a menu is selected, the operator can scroll through related items.

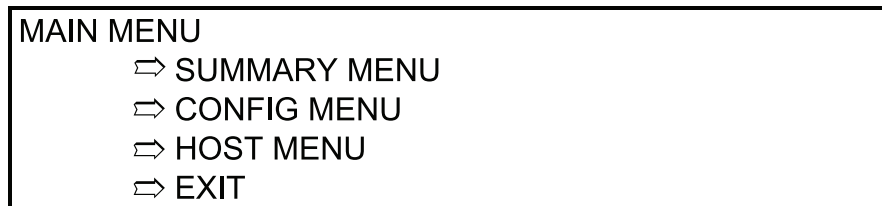

Figure 3-2: ATT Display Mode Menu Tree

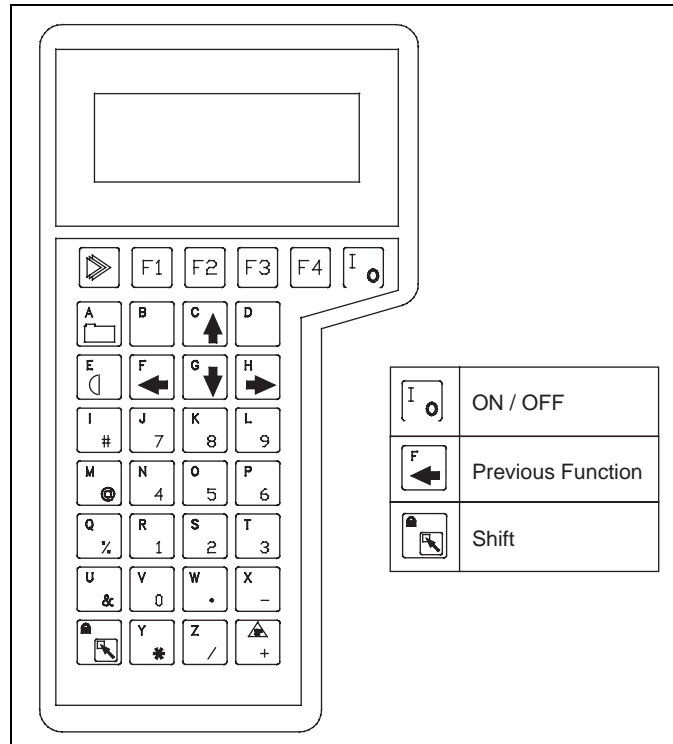

Figure 3-3: 1200 Hand Held Terminal

3.3 Terminal Mode Operation

The 1200 Hand Held Terminal is used to scroll through the various ATT menus. Basic scroll and selection operations are performed using the four function keys (F1 through F4) immediately below the display.

Line 1 of the display contains the menu title. Lines 2 and 3 are item display lines. Line 4 is an error message/status line.

If the item displayed on line 2 is preceded with an "M>", the item being displayed is a menu. You can select the menu by pressing F4 (Enter). If the item is preceded by a "C>" the item being displayed is a command that can be executed by pressing F4 (Enter).

Where:

- F1 = Up
- F2 = Down
- F3 = Alter
- F4 = Enter

3.4 Menu Operation

For example, when the Main Menu is displayed on the top line, pressing F1 (Up) will scroll up through the possible main menu selections while pressing F2 (Down) will scroll down through the possible main menu selections.

Pressing F4 (Enter) will cause the selection of the sub-menu displayed on lines two and three (such as Config Menu). Scrolling through a sub-menu is performed in the same manner as scrolling through the Main Menu using the F1 and F2 keys.

To return to the Main Menu, press the PREVIOUS FUNCTION key [Ü], as shown in Figure 3-3 on page 13.

When a parameter is encountered which is to be changed, pressing the F3 key (Alter) will cause the display of the current parameter in a form which permits its modification.

When a specific set of parameters is available, the F1 and F2 keys can be used to scroll through the valid selections. When the desired selection is displayed, pressing the F4 key (Enter) will cause selection of the new parameter. When the parameter consists of numeric or free format characters, the Model 1200 keyboard can be used to enter the parameter. Note that parameter alteration is not final until the session is completed with the EXIT AND SAVE command from the Main Menu.

To complete parameter alteration, scroll through the Main Menu until the following display is presented, then press F4 (Enter) to exit and save the altered parameters.

If parameter alteration is to be aborted (new parameters not saved), scroll through the **Main Menu** until the following display is presented and press F4 (Enter) to quit without saving alterations. The QUIT or EXIT AND SAVE commands must be initiated before turning off or disconnecting the 1200 Hand Held Terminal.

3.4.1 Main Menu

Main Menu	Description
Quick Setup ²	<p>Initializes the ATT configuration parameters to a variety of preset configurations. Eng Frac 1900, Eng Dec 1900, 0–30 m 1900, 0–20m 1900, Eng Frac 1800, Eng Dec 1800, 0–30 m 1800, 0–20m 1800, Imperial Modbus, or Metric Modbus are valid. Use F1 /F2 keys to select. See section below for details.</p> <p>Warning! Warning! Using Quick Setup will overwrite any old configuration in the ATT and should not be used if only some configuration parameters are to be changed.</p>
Summary Menu ¹	Contains the ATT's process variable data and diagnostic status conditions. See table below.
Config Menu	Contains ATT configuration menu items. See table below.
Host Menu ¹	Contains ATT host communication related configuration menu items. See table below.
Exit and Save ²	Must be used to exit the Alter Mode if configuration data modified are to be used.
Quit/Exit	Used to quit Alter Mode without saving. Also displayed as Exit in display mode.

3.4.2 Summary Menu

Summary Menu	Description
Level	Current level.
Temperature	Current temperature
RTD Resistance	RTD resistance measured
Cfg Error Type	Configuration error type detected.
Power Log	Number of times unit has gone through a power down cycle since it was last configured. Going into Alter Mode and using 'Exit and Save' resets this value to 0.
Bad CPU Board Stat ³	Bad CPU Board Stat3 True if the RAM, ROM, or EEPROM are bad.
Bad RAM Stat ³	True if RAM status is bad.
Bad EProm Stat ³	True if EProm status is bad.
Bad EEPROM Stat ³	True if EEPROM status is bad.
Bad EECsum Stat ³	True if EEPROM checksum does not match the data stored in it.
Bad Comm Board ³	True if communication board failed loopback test
Bad Level Stat ³	True if level is bad.
Bad Temp Stat ³	True if temperature input is out of range.
Low Battery Stat ³	True if battery voltage is low or no battery is connected.
Crit Hi Level Stat ³	True if the level is above the critical high level setpoint
Adv Hi Level Stat ³	True if the level is above the advisory high level setpoint
Adv Lo Level Stat ³	True if the level is below the advisory low level setpoint
Crit Lo Level Stat ³	True if the level is below the critical low level setpoint
Crit Hi Temp Stat ³	True if the temperature is above the critical high temperature setpoint
Adv Hi Temp Stat ³	True if the temperature is above the advisory high temperature setpoint
Adv Lo Temp Stat ³	True if the temperature is below the advisory low temperature setpoint
Crit Lo Temp Stat ³	True if the temperature is below the critical low temperature setpoint

3.4.3 Configuration Menu

Configuration Menu	Description
Level Units	Level units used for display and Modbus data. FT-IN-16TH, M, or FT are valid. Use F1 /F2 to select.
Temp Units	Temperature units used for display and Modbus data. F, C, or K are valid. Use F1 /F2 to select.
Level Sensor	Direction of gauge. Forward/Reverse
Calib Level2	Command used to calibrate to a new level. Pressing F4 causes ATT to ask for the current level to be entered.
Batt Off2	Command used to turn the battery off. Pressing F4 causes the battery to be turned off.
Damping	Damping value used for level and temperature readings. 0-16 is valid.
Temp Sensor	Type of temperature sensor attached. None, Copper RTD, or Platinum RTD are valid. Use F1 /F2 to select.
Manual Temperature	If there is no temperature sensor, this is the value displayed and returned for temperature.
Noise Reject	Sets up the noise rejection for the A/D. 50 and 60 Hz are valid. Use F1 /F2 to select.
Critical High Level	Critical high level alarm setpoint.
Advisory High Level	Advisory high level alarm setpoint.
Advisory Low Level	Advisory Low LevelAdvisory low level alarm setpoint.
Critical Low Level	Critical low level alarm setpoint.
Level Deadband	Deadband used for level alarms.
Critical High Temp	Critical high temperature alarm setpoint.
Advisory High Temp	Advisory high temperature alarm setpoint.
Advisory Low Temp	Advisory low temperature alarm setpoint.
Critical Low Temp	Critical low temperature alarm setpoint.
Temp Deadband	Deadband used for temperature alarms.

3.4.4 Host Menu

Host Menu	Description
Type	Type of host communication interface. Modbus or Mark/Space. Use F1 /F2 to select.
Mark/Space Adr ⁴	Address of ATT on Mark/Space bus. 0–999 is valid.
Low Speed ⁴	Whether or not to use low speed on Mark/Space bus. Yes or No is valid.
Xmtr to Sim ⁴	Type of Mark/Space transmitter to simulate. 1800 or 1900 are valid. Use F1 /F2 to select.
Encoder to Sim ⁴	Type of level encoder to simulate on the Mark/Space bus. Eng Frac, Eng Dec, 0–20m , or 0–30m are valid. Use F1 /F2 to select.
Disable Temp Reply ⁴	If 'YES' disables the temperature portion of the reply on the Mark/Space bus and answer with only a 40 bit reply.If 'NO' the standard 56 bit message is returned with level and temperature. This only applies to the 1800/1900 reply mode for compatibility. Yes or No are valid.
ASU Connected ⁴	If 'YES' replies with the level using a 39 bit message. The ASU is expected to be connected to the Mark/Space bus and will add the temperature portion of the reply to complete a 56 bit response. Yes or No are valid.
Temp to Sim ⁴	Temperature units to simulate on the traditional Mark/Space reply. F or C are valid. Use F1 /F2 to select.
Offset Temp By 100 ⁴	If 'YES' the temperature returned to the Mark/Space host is offset by 100 degrees. This only applies to the 1800/1900 reply mode for compatibility while emulating these transmitters.
Low Battery ⁴	Determines how low battery status is to be reported using the old 1800/1900 reply. None, Hwln1, Hwln2, or Bad Level are valid. Use F1 /F2 to select.
Modbus Address ⁵	Address of ATT on the Modbus bus. 1–254 is valid.
Baud ⁵	Serial baud rate used. 300, 600, 1200, 2400, 4800, and 9600 are valid. Use F1 /F2 to select.
Parity ⁵	Parity used for serial communications. None, Odd, and Even are valid. Use F1 /F2 to select.
Stop Bits ⁵	Number of stop bits used for serial communications. 1 or 2 is valid.
Max Integer ⁶	Maximum integer value used to indicate a full scale value for scaled integer registers. 0 – 65535 is valid.
Min Level ⁶	Value corresponding to a 0% scaled level value.
Max Level ⁶	Value corresponding to a 100% full scale level value.
Min Temp ⁶	Value corresponding to a 0% scaled temperature value.
Max Temp ⁶	Value corresponding to a 100% full scale temperature value.

3.4.5 Notes on Menu Items

¹ Only displayed if in Display Mode

² Only displayed if in Alter Mode

³ Only displayed if TRUE

- ⁴ Only displayed if host interface type is Mark/Space
- ⁵ Only displayed if host interface type is Modbus
- ⁶ Only displayed if host interface type is Modbus or Mark/Space
- ⁷ Only displayed if there is no temperature sensor

3.5 Quick Setup

The Quick Setup option is meant to get the ATT configured quickly and with some defaults. It is **NOT** likely that this configuration will match your installation exactly. However, after the Quick Setup option is selected, you can go through the 1200 Hand Held Terminal menus to see and modify any parameter. Quick Setup simply gives you a starting point.

Warning! The Quick Setup option erases all previous configurations in the ATT's EEPROM. If you use the quick setup command from the 1200 Hand Held Terminal and you change your mind, simply exit the 1200 Hand Held Terminal Main Menu using the QUIT command. This works since no configuration is changed or used unless the EXIT AND SAVE command is executed from the Main Menu.

Please note that Quick Setup also configures all alarm setpoints to such values as not to generate alarms. You must modify the alarm setpoints to match your tank dimensions and your product.

The quick setup default configurations are:

- Imperial fractional 1800
- Imperial decimal 1800
- 0–20 meters 1800
- 0–30 meters 1800
- Imperial fractional 1900
- Imperial decimal 1900
- 0–20 meters 1900
- 0–30 meters 1900
- Imperial Modbus
- Metric Modbus
- Matrix 1600 Metric
- Matrix 1600 Imperial
- Matrix 1700 Metric
- Matrix 1700 Imperial
- Matrix 1700 Metric 0–20 meters
- Matrix 1700 Imperial 0–30 meters
- Matrix 2400 Metric 0–20 meters
- Matrix 2400 Imperial 0–30 meters
- LNJ Metric
- LNJ Imperial
- Whessoe Bus Matrix
- Whessoe Bus Imperial
- GSI Modbus integer scaled
- GPE loop

3.5.1 Imperial Fractional 1900 Quick Setup Defaults

General Configuration	
Level Units	FT-IN-16th
Temp Units	F
Level Sensor	Forward
Damping	0
Temp Sensor	Copper RTD
Manual Temperature	
Critical High Level	80-0-0
Advisory High Level	80-0-0
Advisory Low Level	0
Critical Low Level	0
Level Deadband	0-1-0
Critical High Temp	500
Advisory High Temp	500
Advisory Low Temp	0
Critical Low Temp	0
Temp Deadband	1
Host Configuration	
Type	Mark/Space
Address	999
Low Speed	N
Transmitter to Simulate	1900 MWT
Encoder to Simulate	Eng Frac
Return Temp	Y
Temp To Simulate	F
Offset Temp by 100	Y
Low Battery Indication	Hwln1
Max Integer Value	9999
Minimum Level	0
Maximum Level	80-0-0
Minimum Temperature	0
Maximum Temperature	500

3.5.2 Imperial Decimal 1900 Quick Setup Defaults

General Configuration	
Level Units	FT-IN-16th
Temp Units	F
Level Sensor	Forward
Damping	0
Temp Sensor	Copper RTD
Manual Temperature	
Critical High Level	80.00
Advisory High Level	80.00
Advisory Low Level	0
Critical Low Level	0
Level Deadband	0.83
Critical High Temp	500
Advisory High Temp	500
Advisory Low Temp	0
Critical Low Temp	0
Temp Deadband	1
Host Configuration	
Type	Mark/Space
Address	999
Low Speed	N
Transmitter to Simulate	1900 MWT
Encoder to Simulate	Eng Dec
Return Temp	Y
Temp To Simulate	F
Offset Temp by 100	Y
Low Battery Indication	HwIn1
Max Integer Value	9999
Minimum Level	0
Maximum Level	80.00
Minimum Temperature	0
Maximum Temperature	500

3.5.3 0-20 Meter 1900 Quick Setup Defaults

General Configuration	
Level Units	Meters
Temp Units	C
Level Sensor	Forward
Damping	0
Temp Sensor	Platinum RTD
Manual Temperature	0.0
Critical High Level	20.0
Advisory High Level	20.0
Advisory Low Level	0
Critical Low Level	0
Level Deadband	0.03
Critical High Temp	250.0
Advisory High Temp	250.0
Advisory Low Temp	0
Critical Low Temp	0
Temp Deadband	1
Host Configuration	
Type	Mark/Space
Address	999
Low Speed	N
Transmitter to Simulate	1900 MWT
Encoder to Simulate	0-20M
Return Temp	Y
Temp To Simulate	C
Offset Temp by 100	N
Low Battery Indication	Hwln1
Max Integer Value	9999
Minimum Level	0
Maximum Level	20.0
Minimum Temperature	0
Maximum Temperature	250.0

3.5.4 0-30 Meter 1900 Quick Setup Defaults

General Configuration	
Level Units	Meters
Temp Units	C
Level Sensor	Forward
Damping	0
Temp Sensor	Platinum RTD
Manual Temperature	0.0
Critical High Level	30.0
Advisory High Level	30.0
Advisory Low Level	0
Critical Low Level	0
Level Deadband	0.03
Critical High Temp	250.0
Advisory High Temp	250.0
Advisory Low Temp	0
Critical Low Temp	0
Temp Deadband	1
Host Configuration	
Type	Mark/Space
Address	999
Low Speed	N
Transmitter to Simulate	1900 MWT
Encoder to Simulate	0-30M
Return Temp	Y
Temp To Simulate	C
Offset Temp by 100	Y
Low Battery Indication	HwIn1
Max Integer Value	9999
Minimum Level	0
Maximum Level	30.0
Minimum Temperature	0
Maximum Temperature	250

3.5.5 Imperial Fractional 1800 Series Transmitter Quick Setup

The Imperial fractional 1800 quick setup selection establishes the same default parameters as the Imperial Fractional 1900 quick setup with the exception that the sensor to emulate parameter is the 1800 MWT.

3.5.6 Imperial Decimal 1800 Series Transmitter Quick Setup

The Imperial decimal 1800 quick setup selection establishes the same default parameters as the Imperial decimal 1900 quick setup with the exception that the sensor to emulate parameter is the 1800 MWT.

3.5.7 0-20 Meters 1800 Series Transmitter Quick Setup

The 0–20 meters 1900 quick setup selection establishes the same default parameters as the 0–20 meters 1900 quick setup with the exception that the sensor to emulate parameter is the 1800 MWT.

3.5.8 0-30 Meters 1800 Series Transmitter Quick Setup

The 0–30 meters 1800 quick setup selection establishes the same default parameters as the 0–30 meters 1900 quick setup with the exception that the sensor to emulate parameter is the 1800 MWT.

3.5.9 Imperial Modbus Quick Setup Defaults

General Configuration	
Level Units	FT-IN-16th
Temp Units	F
Level Sensor	Forward
Damping	0
Temp Sensor	Copper RTD
Manual Temperature	
Critical High Level	80-0-0
Advisory High Level	80-0-0
Advisory Low Level	0
Critical Low Level	0
Level Deadband	0-1-0
Critical High Temp	500
Advisory High Temp	500
Advisory Low Temp	0
Critical Low Temp	0
Temp Deadband	1
Host Configuration	
Type	Modbus
Address	254
Baud	9600
Parity	Odd
Stop Bits	1
Max Integer Value	9999
Minimum Level	0
Maximum Level	80-0-0
Minimum Temperature	0
Maximum Temperature	500

3.5.10 Metric Modbus Quick Setup Defaults

General Configuration	
Level Units	Meters
Temp Units	C
Level Sensor	Forward
Damping	0
Temp Sensor	Platinum RTD
Manual Temperature	0.0
Critical High Level	20.0
Advisory High Level	20.0
Advisory Low Level	0
Critical Low Level	0
Level Deadband	0.03
Critical High Temp	250.0
Advisory High Temp	250.0
Advisory Low Temp	0
Critical Low Temp	0
Temp Deadband	1
Host Configuration	
Type	Modbus
Address	254
Baud	9600
Parity	Odd
Stop Bits	1
Max Integer Value	9999
Minimum Level	0
Maximum Level	20.0
Minimum Temperature	0
Maximum Temperature	250.0

4 Maintenance and Troubleshooting

4.1 Maintenance

The Varec Model 4000 Advanced Technology Transmitter (ATT) is designed and manufactured to provide accurate and reliable operation without a requirement for regularly scheduled maintenance.

Due to the modular construction of the ATT, necessary repairs can be quickly and safely accomplished.

Caution! When performing service or repair of any kind on the ATT, follow all instructions relative to power on/off requirements. It is recommended that all necessary repairs be performed by a factory trained service engineer.

4.2 Battery Replacement

The ATT contains a battery module to maintain incremental count information during power outages. The battery shelf life is ten years and active life is 10 days. The ATT monitors the battery voltage and will indicate a low battery status to the host computer. The battery status can also be checked using the Handheld Terminal under the Summary Menu.

The ATT may indicate a low battery condition for several reasons:

- A brand new unit is shipped with the battery turned off.
- The battery is really low or bad.
- Someone has actually turned the battery off from the host computer or via the Handheld Terminal if an extended power outage was anticipated.
- The ATT may have automatically turned its battery off. This occurs to preserve the battery if a power outage occurs for more than a 24 hour period.

Using a Handheld Terminal get into the Alter Mode of operation. Check if the battery is really bad by calibrating the level. This turns on the battery circuitry automatically. Perform an Exit and Save and log back in using the Display Mode. The Summary Menu indicates the status of the battery as tested by the ATT.

Caution! Power to the ATT must be off before attempting to replace the battery. Do not apply power to the ATT until battery replacement is complete and all covers have been replaced.

If the battery is still bad, perform the following to replace it:

1. Turn off all power to the ATT and remove the electronics' cover.
2. Locate the two covered batteries marked BT1 and BT2.
3. Slide off the battery cover.
4. Remove by sliding the batteries to the side and not straight out.
5. Replace with new batteries and replace battery cover.
6. Replace the ATT's cover
7. Turn the power to ATT back on.
8. Calibrate the level.

4.3 Troubleshooting

The ATT has provisions for hardware alarm inputs, software generated setpoint alarms, and other alarm conditions.

Alarm and error status conditions are available to the Model 1200, to the host Computer, and to the optional ATT display. When in the Model 1200 display mode, the Diagnostic Status Menu displays only active alarm and error status conditions. General status conditions such as HW IN 1 are always displayed.

4.3.1 ATT Error Status Conditions

Error Message	Description
BAD COMM BOARD	The communication board did not pass the loopback test. See the description of the host communication loop-back tests.
BAD CPU BOARD	RAM, EPROM, or EEPROM has failed.
BAD EEPROM CHECKSUM	The EEPROM configuration data did not match the EEPROM stored checksum. Examine all configuration parameters, make any changes, and then use the "EXIT AND SAVE" option under the Main Menu.
BAD EEPROM	The value written to EEPROM memory did not match the value read back from EEPROM memory. This is a critical alarm. Contact the factory.
BAD EPROM	The program EPROMs have failed the EPROM test. This is a critical alarm. Contact the factory.
BAD LEVEL	The level input is invalid.
BAD RAM	The RAM has failed the RAM test. This is a critical alarm. Contact the factory.
BAD RTD RESISTANCE	The ATT detected an invalid RTD resistance. Usually due to an open or shorted RTD input.
BAD TEMP	The ATT detected an invalid temperature. Usually due to an RTD failure.
CALC ERROR	Calculation overflow or divide by zero error.
CONFIG ERROR	See the ATT configuration error checking in this section.
LOW BATTERY	The battery used to maintain the encoder circuitry has a low voltage.
NO CALC ERROR	The ATT can no longer perform calculation. See information under the Stop Calculations Conditions section.
OFFLINE MODE	A Model 1200 is connected to the ATT at tank side. No ATTI Bus sensor communication is active.
RTD UNCOVERED	The Resistive Temperature Device (RTD) sensor is uncovered.

4.4 ATT Status Conditions

The ATT provides the following general status condition.

Status Condition	Description
FIELD CONFIG MODIFIED	Set when the configuration is modified from the Model 1200. This status condition will only be available to the host computer and will not appear on the Model 1200.

4.5 ATT Configuration Error Checking

The ATT performs extensive integrity checking on the configuration data before it uses it for calculations. If a configuration error is detected, the ATT will generate a CONFIG ERROR status. The status is displayed on the local display, available to the Model 1200 via the Diagnostic/Status Menu, and available to the host computer. To help isolate the type configuration error, the operator can look at CFG ERROR TYPE item under the Diagnostic/Status Menu.

The following are the type of configuration errors and what causes them. The word 'Invalid' implies that the ATT was expecting one of a certain set of values to be assigned to a particular configuration option. This may have been caused by a sudden power outage, a failure in the EEPROM memory, or an invalid configuration received from a host computer.

Error Message	Description
SCALING VAL	Check the level and temperature scaling values under the Host Comm Menu. The ATT insures that the minimum value is smaller than the maximum value.
ALM SP	Check the four level and four temperature alarm setpoints under the Config Menu. The ATT insures that the critical high setpoint is higher than the advisory high, the advisory high is higher than the advisory low, and the advisory low is higher than the critical low.
ALM DBAND	Check the level and temperature deadbands under the Config Menu. The ATT insures that they are a positive value.
SENS CFG	Check the Level Type and Temperature Type under the Config Menu. The ATT insures that they have valid values.

4.6 Model 1200 Error Messages

The following error messages can be encountered while using the Model 1200.

Error Message	Description
INVALID ANSWER	The operator was expected to enter either a 'Y' for yes or an 'N' for no and something different was entered.
INVALID FLOAT	The operator entered an invalid floating point number. The proper format for floating point entry is <pre>[spaces][sign]number['.'][number]['E'][sign][number]</pre> where the fields surrounded by brackets([]) are optional. Leading spaces are permitted, however spaces within the number are not allowed. A maximum number of 15 characters is allowed. The exponent (value after 'E') cannot be larger than 30 nor less than -30.
INVALID INPUT	The operator was given a choice of two different characters to enter and something else was entered.
INVALID NUMBER	The operator entered an invalid number.
NEGATIVE NUMBER	The operator entered a negative number when asked for a positive float number.
NOT ALTERABLE	The operator attempted to alter a Command, Informational, or Menu Item using the F3 (alter) key.
NOT IN ALTER MODE	The operator attempted to alter a Configuration Item using the F3 (alter) key while in the Display Mode.
TOO MANY CHARACTERS	The operator attempted to enter more than the allowed number of characters.
NUMBER TOO LARGE	The operator entered a number that is beyond the limits of a particular Configuration Item.

4.7 Host Communication Loopback Tests

Communications between a host computer and several field devices, such as the ATT, usually occurs on a single set of wires. Each device is individually addressable by the host computer.

The ATT contains special circuitry that reduces the chance of one ATT shorting the host communication lines. The circuitry allows the ATT to disconnect itself from the communication line and perform a loop-back test.

The test is performed automatically on power-up. It is also performed periodically if communication is no longer detected from the host computer.

If the ATT fails its local loop-back test, it will generate a 'Bad Comm Board' status and disconnect itself from the host communication lines. It will remain disconnected until it can pass its internal loop-back test.

5 Specifications

5.1 Specifications and Physical Characteristics

The following specifications apply to the Varec Model 4000 Advanced Technology Transmitter assembly over the operating temperature range.

5.1.1 Environmental

Item	Specification
Temperature	-40 °C to +85 °C (operating)
Humidity	-0 to 95% (non-condensing)
Transient Lightning	Meets ANSI/IEEE C62.41
EMI	Meets SAMA 33.1C
Vibration Shock	Meets SAMA PMC 31.1

5.1.2 Physical

Item	Specification
Housing	Aluminum NEMA 4X, NEMA 7
Bolts	Plated carbon steel per ASTM A449, Grade 2
Paint	Epoxy-polyester
Dimensions	190.5 mm (7.5") diameter x 203.2 mm (8.0") deep
Net Weight	1.8 kg (4 LB)
Shipping Weight	3.6 kg (8 LB)

5.1.3 Input Power

Item	Specification
4000 M4FMO	48 – 65 VDC
4000 GMFMO	24 – 65 VDC
4000 48 FMO	24 – 65 VDC
4000 TIFMO	60 – 65 VAC
4000 GEFMO	45 – 55 VAC
4000 LJFMO	48 – 65 VDC
4000 MXFMO	48 – 65 VDC
4000 WBFMO	48 – 65 VDC
5 mA typical at 48 VDC	250 mW, Nominal

5.1.4 Level Measurement

Item	Description
Resolution	0.04 in (1.0 mm)
Counter Level Range	+/-128 ft (39 M)
Count Verification	Check Disk
Level Data Type	Absolute with Calibrated Level
Calibration Level	Software Configured
Units of Measure	Software Configured
Direction of Rotation	Software Configured
Rotational Speed	1000 RPM Maximum
Gear Ratio	1:1 – No Gears
Communications Check	Depends on communication system
Count Error Status	Flag to System
Battery Low Status	Flag to System
Battery Operation	336 Hours (with automatic shut-off after 24)
Battery Shelf Life	10 Years

5.2 Safety Agency Approvals

5.2.1 Explosion Proof

The HART Level Encoder is designed to meet the following safety agency approval requirements for explosion proof installations:

Agency Acronym	Agency	Requirement
(FM)	Factory Manual	Approval Standard Class 3600, 3615, 810
(CSA)	Canadian Standards Association	Standard C22.2 No. 0.0, 0.2, 0.4, 0.5, 14, 30, 94, 142
(BASEEFA)	CENELEC	CENELEC Standard EN50014, EN50018
	(UK)	British Standard BS5501, Part 1, 5

5.2.2 Intrinsic Safety

The ATT is not an intrinsically safe device and must not be opened or wired while power is applied.

5.3 Major System Assemblies and Components

The major assemblies and components for the Model 4000 are identified in the following table and illustrated in Figure 5-1.

Item	Assembly/Component	Part Number
1	Shaft/Disk Assembly	06-09478
2	Sensor Assembly	08-09220
3	CPU Assembly	08-10671
4	Batteries, quantity 2	P117-01-004
5	Terminal Board Assembly	08-10702
6	GPE Terminal Board	GPE-08-11515
7	Mark/Space Communications Module	08-10674
8	EIA-485 Communications Module	08-10677
9	Mark Space Matrix	08-10680
10	Whessoe Bus GPE Communications	08-10683
11	TIWAY Communications	08-10828
12	L&J Tankway Communications	08-10909

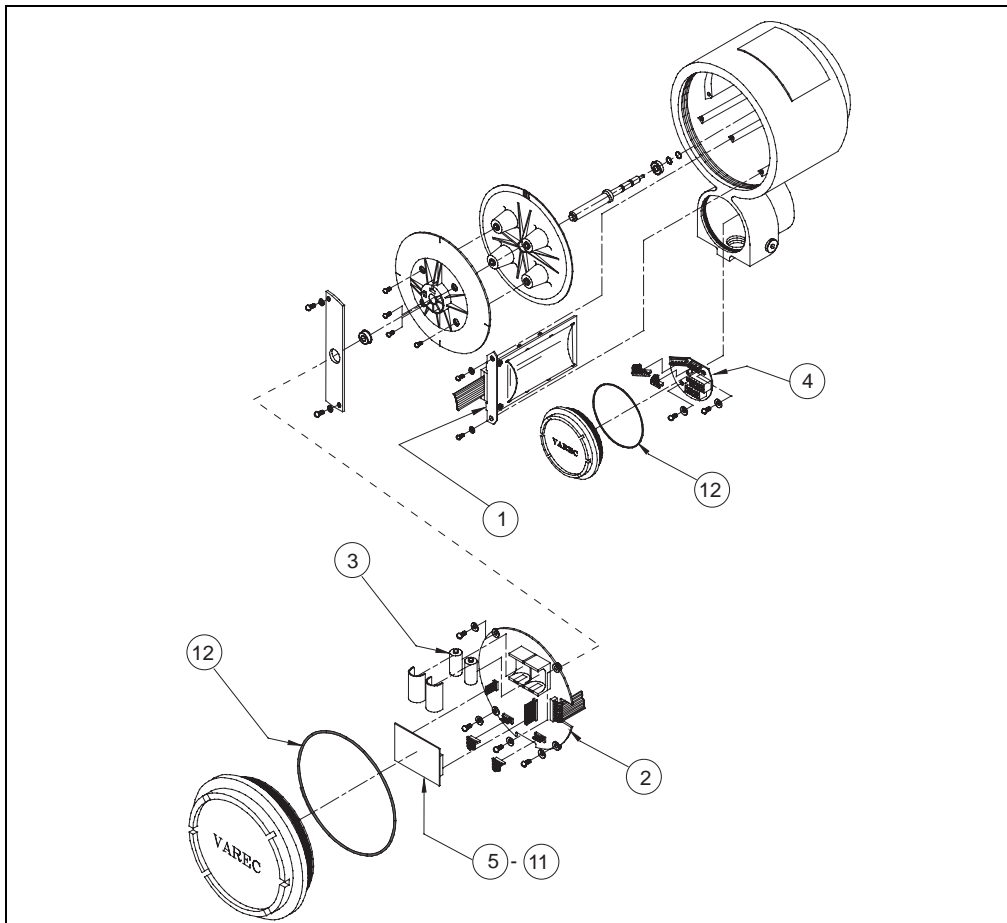

Figure 5-1: ATT Major Assemblies

6 Order Codes

10	Communications		
	GE	GPE Loop Communication	
	MX	Mark Space Matrix (1600/1700)	
	TI	TIWAY Communication	
	WB	Whessoe Bus Current Loop (1315)	
	GM	GSI Type MODBUS	
20	Approvals		
	CS	CSA Cl.I Haz. Loc. (CAN/CSA C22.2, No. 30-M1986)	
	FM	FM Cl.I Gr. C,D; Cl.II Gr. E,F,G Cl.II Haz. Loc. (ETL 557067)	
	AT	DEMKO 04 ATEX 0327020 EEx d II B	
30	Mounting		
	0	Mounting 2500 ATG Series	
	1	L&J (Shand & Jurs) 92513, 92514, 92020, 92030	
	2	Whessoe 2006, 2026, 2036 and L&J (Shand & Jurs) 92006	
	3	Adapter for Sakura LT-101	
N4000 -			Complete product designation

7 Theory of Operation

7.1 Overview

The Advanced Technology Transmitter (ATT) represents a flexible system for use in liquid level measurement and/or other measurement applications.

The Advanced Technology Transmitter (ATT) collects measurement information from compatible devices and transmits this information over a field communications bus.

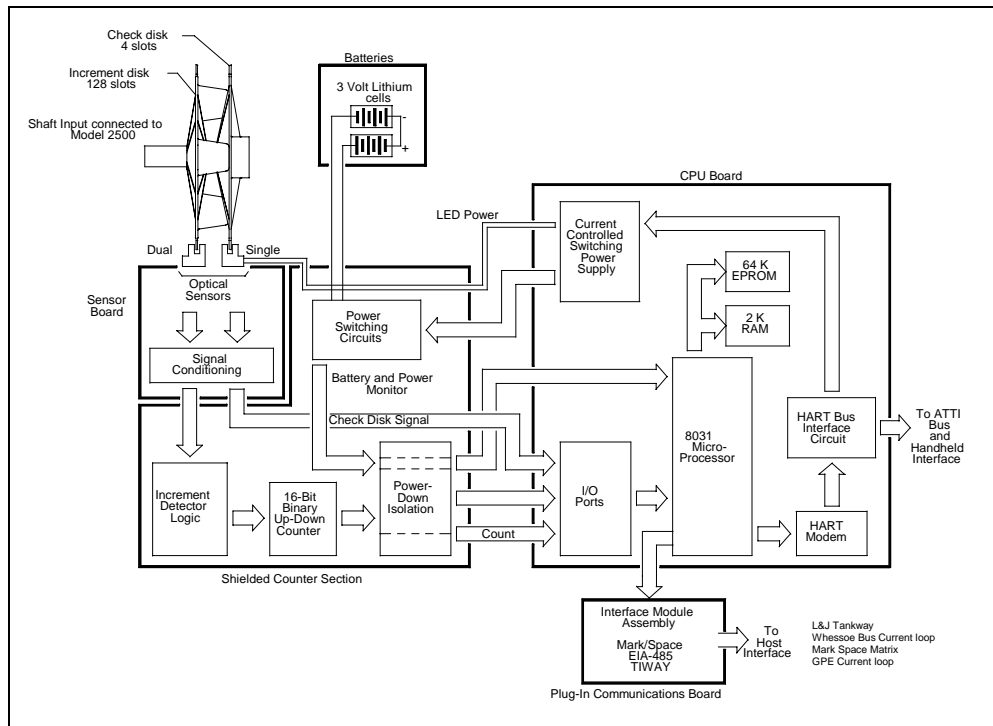

Figure 7-1: ATT Block Diagram Table

7.2 CPU Board

The ATT uses the Phillips 80CL31 CPU with 64K of ROM and 8K of RAM.

The microprocessor assembly contains the CPU, power supply, and interfaces necessary to manage operation. The power conditioning circuitry also detects a battery low condition.

The CPU monitors the count maintained in a 16-bit register. The register stores pulse information from the sensor assembly. A check disk pulse from the sensor assembly is used to verify the count at 1/4 of a disk revolution. The CPU maintains an absolute level measurement based on the level calibration count provided by the ATT and the count provided by the count register. Circuitry is provided to monitor the health of the back-up battery. When the battery voltage indicates the battery is near the end of its life, the CPU transmits a battery low indication to the ATT.

The power supply converts input power from the ATTI bus into the voltages necessary for normal encoder operation. The power supply limits input current from the ATTI bus to 8 mA.

7.3 Status Inputs and Outputs

Status inputs and outputs are accomplished via a separate I/O Module. The ATT will communicate with the Module via the ATTI port. The state of the inputs will be mapped into Modbus registers to allow a host computer to read them. Control of status outputs will also be available to a host via Modbus registers. This unit is currently under development.

7.4 ATTI Communications Port

The ATTI Communication Port is a HART device compatible port. However, it does not power HART devices and is not designed to be intrinsically safe. It is used to communicate with the 1200 Hand Held Terminal for configuration. In the future it will support digital I/O extensions to the ATT including, 4120 Multi-Element Temperature Transmitter and 4040 Tankside display

7.5 Host Communications Interfaces

The ATT supports a plug-in host communication interface module. The following host communication modules are supported in the initial release of the ATT.

- EIA485 Modbus
 - Mark/Space
 - GPE Loop Communications
 - TIWAY Communications
 - L&J Tankway Communications
 - Varec Mark Space Matrix
 - GSI Modbus
-

7.6 Level Measurement

The HART Level Encoder utilizes a proprietary incremental count technique for determining liquid level. Two code disks are provided in the encoder with each disk containing a number of slots. Optical sensors for each disk detect disk rotation by sensing the passing of these slots. The primary disk contains 128 slots and is used to calculate the actual liquid level. The secondary or check disk contains only four slots and is used to verify or check the level from the primary disk. The count obtained from these sensors is stored in encoder memory.

7.6.1 Back-up Battery

The encoder's back-up battery provides continuous operation during power outages. The battery is non-rechargeable with a continuous operating lifetime of 10 days or more and a shelf life of ten years. To preserve the battery life, automatic battery shut down occurs after 24 hours of continuous power outage. The encoder monitors the voltage of the back-up battery and provides a battery low warning to the host in the event the battery needs replacement or has been turned shutdown due to an extended power outage.

7.6.2 Damping

The ATT implements a damping scheme to stabilize the level and temperature in turbulent tanks. The amount of damping is specified by a damping value in the 'DAMPING' parameter under the Config Menu. This parameter can be entered via the Model 1200 using the Alter menu.

A damping value of 0 to 16 can be specified. A damping value of 0 implies no damping. A damping value of 16 implies that level and temperature is averaged over 16 readings.

7.7 Encoder Battery Backup

The ATT includes battery backup for the encoder. This allows level to be maintained across a power failure. Several considerations are made to protect the battery from being fully discharged.

1. The battery must be physically enabled by the microprocessor. This allows the battery to be shipped connected without being discharged.
2. Service personnel can turn the battery off. This will allow the battery to be disabled when a tank or a transmitter is to be taken out of service for an extended period of time.
3. On-board circuitry limits the battery backup time to 24 hours. This allows battery life to be extended even if service personnel forget to disable the battery during extended power outage conditions.

The battery is automatically turned on when the ATT is calibrated with a given level.

7.8 Temperature Measurement

The ATT measures temperature directly using a high accuracy 16 bit analog to digital converter. Temperature inputs can be either a 3-wire Copper or Platinum RTD. Optionally the temperature can be manually entered. The 4120 Multi-Element Temperature transmitter can be used as a replacement to a spot temperature bulb (RTD).

7.9 Host Communication

The Modbus host interface permits the ATT to directly communicate with any distributed control system utilizing the Gould Modbus protocol. The Modbus protocol defines two data formats, ASCII and RTU. The RTU format specifies that all data is in binary. The ASCII format specifies that all data is in ASCII (producing messages twice as long as RTU format messages). The ATT only supports the RTU message format.

The Modbus protocol permits a host computer to view field devices as having analog input registers, analog output registers, digital input registers, and digital output registers. Measured parameters, configuration parameters, and status conditions are mapped to Modbus analog and digital registers.

A non-standard Modbus floating point register extension has been defined for use by the ATT. This format extension permits floating point data to be directly read from and written to any Modbus device. The IEEE 754 standard floating point format is used. Each floating point register consists of four bytes.

To provide compatibility with future enhancements, data written to undefined registers are accepted and ignored. Data read from undefined registers returns a value of zero (0).

The supported Modbus functions and exceptions are indicated in the following tables.

Function Number	Function
01	Read Digital Outputs
02	Read Digital Inputs
03	Read Analog Output Registers
04	Read Analog Input Registers
05	Write Single Digital Output
06	Write Single Analog Output Register
08	Loopback Test
15	Write Multiple Digital Outputs
16	Write Multiple Analog Output Registers
65	Read Floating Point Registers
66	Write Floating Point Registers

Table 7-1: Modbus Functions

Number	Exception
01	Illegal Function
02	Illegal Address
03	Illegal Data
04	Busy

Table 7-2: Modbus Exception Responses

7.10 Mark/Space Host Interface

The Mark/Space interface provides compatibility with existing Mark/Space data highways. The interface operates in one of two modes.

- Transmitter Emulation Mode
 - Varec 1800 Transmitter Emulation
 - Varec 1900 Transmitter Emulation
- Mark/Space Modbus Communication Mode

When operating in the 1800 or 1900 emulation mode, the ATT is compatible with all existing Varec field interfaces such as the Tank Polling Unit (TSU) or RTU 8130.

The ATT automatically determines if it is being polled as an 1800/1900 transmitter. When polled, the ATT will respond based on the configured emulation mode. The ATT can be configured to support the following encoding formats:

- Imperial Fractional
- Imperial Decimal
- Metric, 0–20 meter
- Metric, 0–30 meter

When emulating an 1800 or 1900, battery low status can be reported as one of the dry-contact inputs or as an invalid level.

Note! The ATT will accept but ignore the Raise/Lower Displacer commands.

7.11 Modbus Support over Mark/Space Host Interface

The ATT permits Modbus communications over the Mark/Space data highway. The Modbus request message is placed into a Mark/Space message frame. The ATT processes the request message and places the Modbus reply in a Mark/Space reply frame.

This option is only available with systems using the Model 6840 Tank Polling Unit.

7.12 Compatibility with Varec Tank Polling Unit

The Mark/Space communications provided by the ATT are compatible with the Varec Tank Polling Unit (TPU). This permits the ATT to be multi-dropped on the same Mark/Space data highway as the Varec 1800, Varec 1900, and MFT/HIU devices.

If the EIA485 communications interface is installed in the ATT, it can be multi-dropped on an EIA485 data highway, RTU 8130 along with any Modbus compatible device, including the Model 6850 Field Interface Converter.

8 ATT Family of Products

The ATT product family consists of the 4000 ATT, the Model 4040 Display Unit, and the Model 4050 Digital Input/Output Unit.

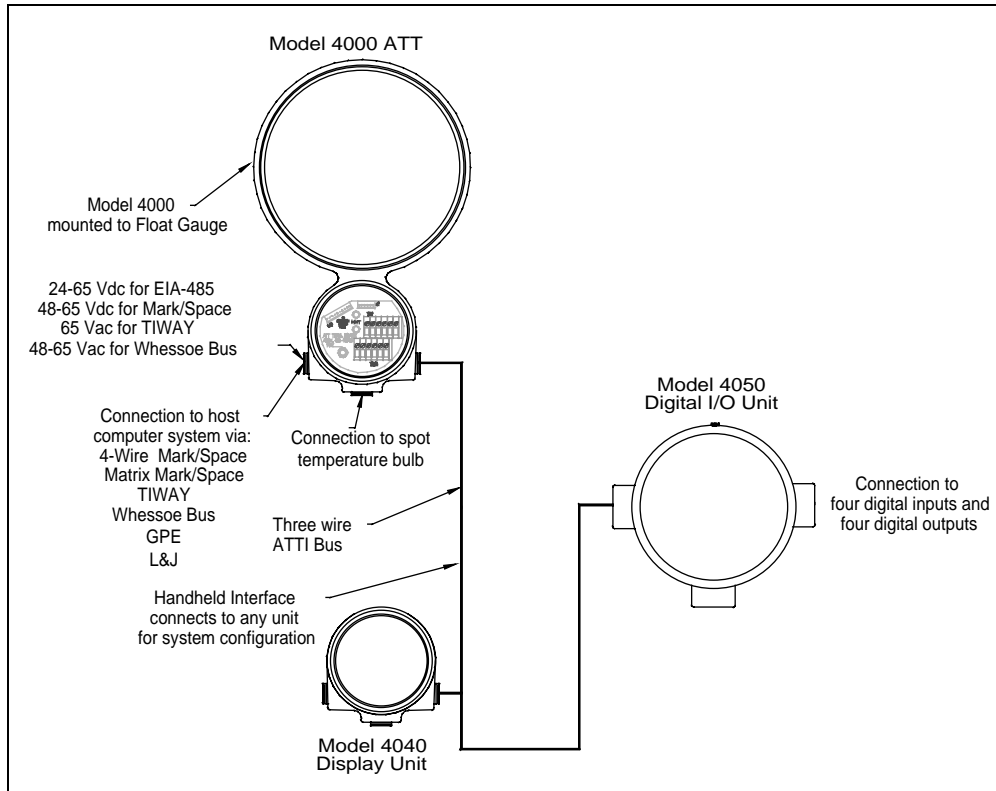

Figure 8-1: ATT Family of Products

8.1 Model 4040 Display Unit

The Model 4040 is a four line LCD display unit. It operates connected to and is powered from the ATTI bus. The Unit is mounted in a round explosion proof junction box with a window. Two 3/4-inch conduit entries are available.

Configuration is performed with the handheld interface. The handheld interface can be connected to any point on the ATTI bus to communicate with the Model 4040. The user may select any of the following parameters for display on each of the three lines.

- Level (default)
- Temperature (RTD – default, or Average)
- Status (default)
- Digital I/O Unit 4, 5 or 6
 - Input 1-2-3-4
 - Output 1-2-3-4
- Analog I/O Unit 7, 8 or 9
 - Input 1-2-3-4
 - Output 1-2-3-4

8.2 Model 4050 Digital Input/Output Unit

The Model 4050 is a digital I/O unit. It includes four digital contact closure outputs and four digital inputs. It operates connected to and is powered from the ATTI bus. The unit is mounted in a round explosion proof junction box. Three 3/4-inch conduit entries are available.

- Primarily configured by jumpers. Three sets of jumpers are used.
- Unit address: 4 jumpers for range 0–15. Digital I/O units normally use address 4,5 or 6.
- Active state jumper for each digital output. Jumper determines if contact is N. O. or N. C.
- Default power condition for each digital output. Jumper determines if contact is open or closed when no power is applied.

8.2.1 Digital Outputs

The use of the digital outputs is configured within the ATT using the handheld interface. Digital outputs 1 – 4 can be configured as follows:

1. Set output as level switch:
 - Set for low or high closure.
 - Set level to actuate.
2. Set output for Modbus command to write.

8.2.2 Digital Inputs

Digital inputs 1 – 4, can each be read with a Modbus command.

8.2.3 Relay Specifications

The latching relays will switch 110 VAC at 1 A or 24 VDC at 2 A. The unit does not support 220/230 VAC.

9 Modbus Implementation

9.1 Introduction

This protocol guide explains the operation of the Modbus protocol as described in the following Modicon document:

PI-MBUS-300 Rev B (1985) implemented in the Varec Model 4000 Advanced Technology Transmitter (ATT).

9.2 Implementation

The implementation of the Modbus protocol for the ATT provides a standard form of digital communications. An effort has been made to parallel current implementations to the greatest extent possible, so that the ATT communicates with existing Modbus masters.

Check compatibility carefully to ensure that the ATT is properly configured for the data format expected by the host computer. Exceptions made because of the unique requirements of the ATT application have been noted. This is no guarantee, however, that the interpretation made here will be the same as that followed by the Modbus master.

The ATT implementation of the Modbus protocol provides for the passing of measured and calculated variables, configuration information, and diagnostics in data registers. Data is sent in these registers as floating-point values, integer values, numeric codes related to configuration lists, status summary words (packed bits), or individual status flags (single bits).

One master and up to 31 ATTs may be multi-dropped on a single EIA485 communication bus.

The Modbus functions implemented in the ATT are listed in Figure 9-1 on page 46.

9.3 Configuration

The Modbus port on the ATT must be configured to establish communications. The Model 1200 Handheld Interface allows the user to set the ATT Modbus port to match the Modbus master.

ATT addresses provide unique identification for the host. The ATT address is configurable through the Model 1200. This address may range from 1 to 254 and must be unique. Each ATT only responds when a query has been sent to its unique address by the host.

The Modbus protocol supports two modes of transmission, Remote Terminal Unit (RTU) or ASCII (American Standard Code for Information Interchange). The choice between these two modes is dependent on the preference of the host. RTU is often the preferred protocol because of its improved error detection capabilities and higher throughput. ASCII mode uses ASCII printable characters to represent hexadecimal values. This mode of transmission requires almost twice as many characters to pass information as does the RTU transmission mode. The ATT only supports the RTU mode of communications.

Function Code	Function	Information Type	Modbus Nomenclature
01	Read	Bits	Read output status
02	Read	Bits	Read input status
03	Read	Integer, Code, Status word, Floating point	Read output registers
04	Read	Integer, Code, Status word, Floating point	Read input registers
05	Write	Bits	Force single output status
06	Write	Integer, Code, Status word	Preset single register
08	n/a	Repeat of Loopback Message	Loopback test
15	Write	Bits	Force multiple outputs
16	Write	Integer, Code, Status word, Floating point	Preset multiple registers
65	Read	Floating point	Read floating point registers
66	Write	Floating point	Write floating point registers

Table 9-1: Modbus Functions

Note! Exception: Because the ATT does not distinguish between inputs and outputs, function codes 01 and 02 as they apply to bits, and function codes 03 and 04 as they apply to numeric values refer to the same data registers. For example, either function code 03 or function 04 can be used to read the integer form of the true mass variable at data address 0053.

Configuration Item	Valid Entries	Modbus Configurable	Model 1200 Configurable
Modbus Address	1 to 254	No	Yes
Maximum Integer Size	Whole number (0 to 65,534)	Yes	Yes
Integer Scaling Factors	Floating point number	Yes	Yes
Unit Selection	Coding list	Yes	Yes
Baud Rate	300, 600, 1200, 2400, 4800, 9600	No	Yes
Number of Stop Bits	1 or 2	No	Yes
Parity	Odd, Even, None	No	Yes

Table 9-2: Modbus Configuration Information

9.4 Functions and Data Formats

The Modbus data in the ATT is arranged in integer registers, floating point registers, and status bits. The assignments for these registers are found at the end of this appendix.

Function codes 03, 04, 06, and 16 are used with integer registers.

Because of the multiple Modbus hosts available today, the ATT supports two floating-point data formats: a two 16-bit register format and a one 32-bit register format. These two formats provide maximum system flexibility. In the two 16-bit registers format, function codes 03 and 04 are used to read floating-point registers while function code 16 is used to write floating-point registers. In the one 32-bit register format, function code 65 is used to read floating-point registers, while function code 66 is used to write floating-point registers.

Function codes 01, 02, 05, and 15 are used with status bits.

A complete description of all the preceding commands, except floating point, can be found in the Modicon Modbus Protocol Reference Guide, document number PI-MBUS-300 Rev B.

9.5 Integer Registers

Integer registers are the most commonly used type of Modbus data and are supported by most Modbus hosts. In the ATT implementation, the Modbus registers are arranged in one of the following four formats:

- Integer Data – a scaled number from 0 to the maximum Modbus integer
- Character Data – 2 ASCII characters per 16-bit register (ex. date, password)
- Coded Data – Multiple choice configuration data chosen from a coded list
- Packed Bit Data – Register form of 16 packed single bits

The integer, character, and coded data registers contain all of the information needed to configure and read process data. Any integer register may be read with function code 03 or function code 04. These same registers may be written one at a time with function code 06 or multiple registers can be written with function code 16.

For future compatibility, the ATT accepts reads and writes to reserved registers. Writes to reserved registers have no effect. Reads from reserved registers return a zero (0).

Term	Definition
Address	User-assigned address of the slave device
Function Code	Function the slave is to perform
Start Register (H)	High-order data address byte of the number of registers to read or write
Start Register (L)	Low-order data address byte of the first register to read or write
Number of Registers (H)	High-order byte of the number of registers to read or write
Number of Registers (L)	Low-order byte of the number of registers to read or write
Byte Count	Number of data bytes
Data MSB	Data register's most significant byte
Data LSB	Data register's least significant byte
Status Bit (H)	High-order data address byte of the first bit to read or write
Status Bit (L)	Low-order data address byte of the first bit to read or write
Error Check	Message checksum CRC (Cyclical Redundancy Check)

Note! In all of the following communication examples, the error check value is dependent upon the mode of transmission.

9.5.1 Integer Data

The integer data is a whole number between 0 and the maximum Modbus integer (inclusive). The maximum Modbus integer is a user-configurable variable that is a whole number between 0 and 65,535 (inclusive). The integer data must also be scaled for each data type by entering the desired units, a minimum, and a maximum value. In order for the integer value to be correctly interpreted, these scaling factors must match the format expected by the host system. Scaling of the integer parameters is accomplished through floating-point registers or by using the Model 1200 Handheld Interface.

The following communication example shows the request for one register starting at register 0 (0000 Hex).

For the following example, assume:

- minimum = 1 meter
- maximum = 15 meters
- maximum Modbus integer = 65,534

Host Request						
Address	Function Code	Start Reg H	Start Reg L	# of Reg H	# of Reg L	Error Check
01	03	00	00	00	01	XX
ATT Response						
Address	Function code	Byte Count	Data MSB	Data LSB	Error Check	
01	03	02	41	24	XX	

9.5.2 Integer Data

- Hexadecimal representation
- 4124Decimal equivalent: 16,676

The data returned for data address 56 is 16,676 (4124 Hex). This value must be scaled using the following formula to give it meaning.

$$\text{result} = \frac{\text{data} * (\text{max} - \text{min})}{\text{max integer value}} + \text{min}$$

$$\text{result} = \frac{16,676 * (15 - 1)}{65,534} + 1$$

$$\text{result} = 4.54 \text{ meters}$$

If a variable goes out-of-bounds (outside the minimum or maximum scale points), a value equal to the maximum Modbus integer + 1 is returned. Writing to dynamically calculated parameters has no effect on those parameters.

9.5.3 Character Data

Character data, such as software version, are returned in registers in ASCII data format. Each Modbus register represents two ASCII characters.

The following communication example shows the character data "ATT-" read from the ATT.

Host Request							
Address	Function Code	Start Reg H	Start Reg L	# of Reg H	# of Reg L	Error Check	
01	03	00	1E	00	02	XX	
ATT Response							
Address	Function code	Byte Count	Data MSB	Data LSB	Data MSB	Data LSB	Error Check
01	03	04	41	54	54	2D	XX

- Hexadecimal representation 41 54 54 2D
- ASCII representation: ATT-

9.5.4 Coded Data

Coded data represents a table look-up value. Data written to these registers must be a valid table entry. Invalid data may cause a Configuration Error to occur. The following example shows coded data at data address 20 (0014 Hex) representing level units. The value 2 (0002 Hex) returned from the ATT corresponds to level units = FT-IN-16TH.

Host Request						
Address	Function Code	Start Reg H	Start Reg L	# of Reg H	# of Reg L	Error Check
01	03	00	14	00	01	XX
ATT Response						
Address	Function code	Byte Count	Data MSB	Data LSB	Error Check	
01	03	02	00	02	XX	

- Hexadecimal representation 0002 (decimal 2)
- Level unit table representation: FT-IN-16TH

9.5.5 Packed Bit Data

Packed bits represent 16 individual status bits packed into one register. The status bits have been packed this way for systems that prefer handling only register information. These bits may also be read or written individually using a bit command. The bits within the packed registers are grouped by data or function type. The following communication example of packed bits shows alarm status information at data address 5 (0005 Hex) returned by the ATT.

Host Request						
Address	Function Code	Start Reg H	Start Reg L	# of Reg H	# of Reg L	Error Check
01	03	00	05	00	01	XX
ATT Response						
Address	Function code	Byte Count	Data MSB	Data LSB	Error Check	
01	03	02	00	01	XX	

Note! Bit #0 is ON indicating a critical low level Alarm

9.6 Floating-Point Registers

Although not part of the Modbus protocol specification, floating point numbers have been implemented using the IEEE 754 standard. Floating point numbers reduce the complexity required in scaling integer values and provide a means to transmit numbers used by the ATT that are not easily scaled (such as the scaling factors themselves).

9.6.1 Floating-Point Data

The ATT is capable of using a two 16-bit registers format and a one 32-bit register format. Examples and descriptions of both formats follow.

Note! Although this type of data does not require scaling, it is important that the measurement unit selected in the ATT be the same as that expected by the host. In addition, where possible, data is available in both integer and floating-point formats.

9.6.2 The Two 16-bit Registers Format

Function code 03 or 04 is used to read floating-point registers in this format. Function code 16 is used to write floating-point registers in this format. An example of reading the temperature, register 102 (0066 Hex), in floating-point format from the ATT is shown as follows:

Host Request							
Address	Function Code	Start Reg H	Start Reg L	# of Reg H	# of Reg L	Error Check	
01	03	00	66	00	02	XX	
ATT Response							
Address	Function code	Byte Count	Data MSB	Data LSB	Data MSB	Data LSB	Error Check
01	03	04	42	C8	00	00	XX

9.6.3 Floating Point Data

- Hexadecimal representation: 42 C8 00 00
- Decimal equivalent: 100.00

Floating-point registers that are defined as reserved have zero (0) as their only legal value. A write command to a reserved floating-point register is ignored.

9.6.4 The One 32-bit Register Format

Function code 65 (41 Hex) is used to read floating-point registers in this format. An example of a floating-point register read is shown below with the a temperature of 100.0 degrees is being read from register 1 (0001 Hex).

Host Request								
Address	Function Code	Start Reg H	Start RegL	# of Reg H	# of Reg L	Error Check		
01	41	00	01	00	01	XX		
ATT Response								
Address	Function code	# of Reg H	# of Reg L	Data MSB	Data	Data	Data LSB	Error Check
01	41	00	01	42	C8	00	00	XX

9.6.5 Floating Point Data

- Hexadecimal representation: 42 C8 00 00
- Decimal equivalent: 100.00

Function code 66 (42 Hex) is used to write floating-point registers. An example of a floating-point register write is shown below with the value 100.0 being written into the Advisory High Temperature Alarm Setpoint, register 12 (000C Hex).

Host Request						
Address	Function Code	Start Reg H	Start Reg L	# of Reg H	# of Reg L	Data MSB
01	42	00	0C	00	01	42
			Data	Data	Data	Error Check
			C8	00	00	XX
ATT Response						
Address	Function code	# of Reg H	# of Reg L	Error Check		
01	03	02	41	XX		

9.6.6 Floating Point Data

- Hexadecimal representation: 42 C8 00 00
- Decimal equivalent: 100.00

Floating-point registers that are defined as reserved have zero (0) as their value. A write command to a reserved floating-point register will be ignored.

9.7 Status Bits

In the ATT implementation, status bits contain alarms, commands, and status information. The state of a Modbus status bit is defined as either ON (true) or OFF (false). The ON state is represented by a "1". The status bits may be read with function code 1 or 2. They may be written one at a time with function code 5 or multiple bits may be written with function code 15. An example of a read message for bits 2 through 6 as returned by the ATT is shown as follows.

Host Request						
Address	Function Code	Start Reg H	Start Reg L	# of Reg H	# of Reg L	Error Check
01	02	00	02	00	04	XX
ATT Response						
Address	Function code	Byte Count	Data	Error Check		
01	02	01	12	XX		

9.7.1 Status Bit Data

Binary representation 1 0010 (bits 6–2)

Bit #2: High Advisory Alarm OFF

Bit #3: High Critical Alarm ON

Bit #4: Unauthorized Mass Movement OFF

Bit #5: Standard Density Alarm OFF

Bit #6: Critical Zone Alarm ON

9.8 Exception Responses

The exception responses returned by the ATT are listed below:

Exception	Response	Reason
01	Illegal Function	Message is not allowed
02	Illegal Data Address	Data address (bit or register) requested is not defined
03	Illegal Data Value	Data value being written is out of range
04	Busy	During power-up

In addition, messages that are received with a parity error, checksum error, or message format error will be ignored.

9.9 Data Out of Range

When integer data calculated by the ATT is outside the minimum or maximum scale points or is otherwise out of range, the value returned is that of the maximum Modbus integer + 1. For example, if the maximum Modbus integer is 65,534 (as used in our previous examples) the "data out of range" value is 65,535. The "data out of range" convention does not apply to the status bits, packed status bits, character data, and coded data.

The following error conditions will also cause the ATT to return scaled integer values of maximum Modbus integer + 1.

- Off-line Mode
- Strap Error
- No CALC
- API Correction Error
- CALC Error

This permits a host to detect a serious failure without monitoring other ATT status bits.

9.10 Loopback Test

In accordance with the Modbus specification, function code 8 initiates a loopback test. The purpose of this test is to check the communication system. It does not affect the operation of the ATT. The ATT supports only diagnostic code 00. This is a request to return query data. Upon receiving a loopback message containing this code, the ATT will echo the message sent by the host. The entire message returned will be identical to the message transmitted by the host field-per-field. An example of a loopback message is as follows:

Host Request						
Address	Function Code	Code HO	Code LO	Data	Data	Error Check
01	08	00	02	F3	26	XX
ATT Response						
Address	Function code	Code HO	Code LO	Data	Data	Error Check
01	08	00	00	F3	26	XX

9.11 Hardware Implementation

The ATT uses a 2-Wire EIA485 hardware interface to communicate with the Modbus master. EIA485 is a high speed differential communications network which allows up to 32 devices to operate on one network. The ATT and Modbus master share a twisted pair of wires to communicate.

The communication distance EIA485 can reliably travel is dependent on baud rate (communication speed), wire quality, environmental noise, wiring configuration, and the number of multi-dropped ATTs. The recommended wire for EIA485 systems is 18-gauge or larger, shielded, twisted pairs. The shield should be earth grounded at the Modbus master (control system or computer end). The shield at the ATT should be open. The ATT- power line acts as a common reference tie to the Modbus master

Termination resistors of 120 Ohms are shown at each end of the communication bus to minimize reflections on the line. Termination resistors may not be necessary at baud rates of 9600 bits per second or slower. Pull-up and pull-down resistors are also shown at the Modbus master end of the cable. These resistors minimize the affects of noise when the lines are idle. Only one set of pull-up or pull-down resistors are required per twisted pair cable.

9.12 Integer Register Map

Register Number	Type	Description
0	Scaled	Level
1	Scaled	Temperature
2	Reserved	
3	Reserved	
4	Reserved	
5	Bit Field	AimStat <u>Bit Usage</u> 0 CRIT LO LEVEL 1 ADV LO LEVEL 2 ADV HI LEVEL 3 CRIT HI LEVEL 4 CRIT LO TEMP 5 ADV LO TEMP 6 ADV HI TEMP 7 CRIT HI TEMP 8 HW IN 1 9 HW IN 2 10 ..15 RESERVED
6	Bit Field	DiagStat <u>Bit Usage</u> 0 BAD LEVEL 1 BAD TEMP 2 BAD EE 3 BAD EE CKSUM 4 BAD RAM 5 BAD EPROM 6 LOCAL MODS 7 NO CALC 8 CFG ERROR 9 CALC ERROR 10 BAD CPU BOARD 11 BAD COMM BOARD 12 LOW ENC BATT 13.15 RESERVED
7	Bit Field	CmdsBit Usage 0 CANCEL ALT 1 CLR LOCAL MODS 2 RESTART 3 SAVE TO EE 4 RESERVED 5 CALIB LEVEL 6 ENC BATT OFF 7 QUICK SETUP 8.15 RESERVED

Register Number	Type	Description
8	Reserved Code	A/D Noise Reject: Type 0 - 60Hz 1 - 50 Hz
9		
10	Scaled	Crit Low Level Setpoint Adv Low Level Setpoint Adv High Level Setpoint Crit High Level Setpoint Level Deadband Crit Low Temp Setpoint Adv Low Temp Setpoint Adv High Temp Setpoint Crit High Temp Setpoint Temp Deadband
11	Scaled	
12	Scaled	
13	Scaled	
14	Scaled	
15	Scaled	
16	Scaled	
17	Scaled	
18	Scaled	
19	Scaled	
20	Code	Level Units 0 - METERS 1 - FEET 2 - FT-IN-16TH
21	Code	Temp Units 0 - C 1 - F 2 - K
22	Code	Level Type 1 - FORWARD 2 - REVERSE
23	Code	Temp Type 0 - NONE 1 - COPPER RTD 2 - PLATINUM RTD
24	Scaled	Manual Temperature Max Integer Value Damping Value Calibration Level
25	Code	
26	Code	
27	Scaled	
28	Code	Quick Setup Option 0 - NONE 1 - ENG FRAC 1800 2 - ENG DEC 1800 3 - 0 TO 20 M 1800 4 - 0 TO 30M 1800 5 - ENG FRAC 1900 6 - ENG DEC 1900 7 - 0 TO 20 M 1900 8 - 0 TO 30M 1900 9 - METRIC Modbus 10 - IMPERIAL Modbus

Register Number	Type	Description
29	Reserved	
30	ASCII	Sw Ver[0-1] AT
31	ASCII	Sw Ver[2-3] T-
32	ASCII	Sw Ver[4-5]
33	ASCII	Sw Ver[6-7]
34..99	Reserved	
100	Float	
102	Float	
104	Float	Level
106	Reserved Float	Temp
108	Reserved Float	RTD Resist
110	Float	
112	Float	
114	Float	
116	Float	Crit Low Level
118	Float	Adv Low Level
120	Float	Adv High Level
122	Float	Crit High Level
124	Float	Level Deadband
126	Float	Crit Low Temp
128	Float	Adv Low Temp
130	Float	Adv High Temp
132	Float	Crit High Level
134	Float	Temp Deadband
136	Float	Min Level
138	Reserved Float	Max Level
140	Float	Min Temp
142	Float	Max Temp
144...199	Reserved	
200	Float	Man Temp
202	Float	Calib Level
204	Float	Level
206	Reserved Float	Temp
208	Reserved Float	RTD Resist
210	Bit Field	AlmStat
211	Bit Field	DiagStat
212	Reserved	Reserved
213	Reserved	
214	Reserved	
215	Code	Level Units
216	Code	Temp Units
217	Reserved	Reserved
218	Reserved	
219	Reserved	
220	Code	Level Type
221	Code	Temp Type
222	Reserved	Reserved

Register Number	Type	Description
223	Reserved	
224	Reserved	
225	Code	Damping Value
226	Code	A/D Noise Reject: Type
227	Reserved	Reserved
228	Reserved	
229	Reserved	
230	Float	Crit Low Level
232	Float	Adv Low Level
234	Float	Adv High Level
236	Float	Crit High Level
238	Float	Level Deadband
240	Float	Crit Low Temp
242	Float	Adv Low Temp
244	Float	Adv High Temp
246	Float	Crit High Level
248	Float	Temp Deadband
250	Float	Min Level
252	Float	Max Level
254	Float	Min Temp
256	Float	Max Temp
258	Reserved Float	Man Temp
260	Float	

9.13 Floating Point Register Map

Register Number	Description
0	1
2	3
4	5
6	7
8	9
10	11
12	13
14	15
16	17
18	19
20	21
Level	Temp
RTD Resist	Reserved
Reserved	Crit Low Level
Adv Low Level	Adv High Level
Crit High Level	Level Deadband
Crit Low Temp	Adv Low Temp
Adv High Temp	Crit High Level
Temp Deadband	Min Level
Max Level	Min Temp
Max Temp	Reserved
Man Temp	Calib Level

9.14 Status Bit Register Map

Register Number	Description
0..15	16..31
32..47	AlmStat
Diag Stat	Cmds

10 Optional Interfaces

Our intent with these optional interfaces is enabling the ATT to coexist along side older VAREC style and competitor gauging systems and transmitters. This allows the user upward migration to modern gauging systems such as the RS-485 signal interface utilizing the MODBUS register set protocol. When ready to migrate to modern systems, a simple exchange of the ATT communications module is required.

10.1 4000TIFMO

This option is compatible along side TIWAY™ transmitters. Although the ATT can coexist along side all of the TYWAY™ transmitters, the communication option is restricted to the HDLC Link Level Protocol, utilizing IT111 primitives. The ATT is also compatible "user selectable" with an earlier version of the TYWAY™ protocol "CIM".

The ATT has user selectable configuration jumpers to apply 120-ohm termination in case maximum baud rates and wiring distances are implemented.

This ATT option is compatible to utilize the companion products Model 4040 Tank side Display and the Model 4050, 4 channel Digital Input and outputs.

10.2 4000GEFMO

This option is compatible along side GSI / L&J transmitters. Although the ATT can coexist along side any current loop mode transmitters, the communication option is restricted to the GPE Level Protocol format. This format utilizes what we refer to as short and long data responses regarding level, temperature, and status. Because of the nature of this protocol the temperature range of the RTD is limited to -200°C to +200° C.

10.3 4000LJFMO

This option can co-exist with L&J Tankway™ Host gauging system and ` transmitters. Basically it is a signal format similar to RS-232, however signal voltage levels are in the 0 to 35 VDC range. Basic user selectable baud rate, stop and parity bits. Transmitter address is selectable between 1 and 127; protocol is simple in nature of 2 bytes up and 2 bytes back. Response data consist of product level and temperature, encoder gray code and 2 status bits for error checking and data validity.

10.4 4000MXFMO

This option can co-exist along side VAREC style matrix transmitters. As implied a transmitter is selected actively by either the 48-volt or the common line in the matrix. When selected 3 milliseconds later the transmitter sends the level data over the Mark Space data lines. This is referred to as hard wire logic, which occurs only once when selected, it is as if the transmitter is asleep only to wake up send data and go back to sleep. There are no communications parameters to select because only 1 transmitter can be triggered in the matrix at one given time.

10.5 4000WBFMO

This option can co-exist along side Whessoe Bus™ transmitters, the signal format is a current loop style transmission signal. Transmitter is user selectable between 1 and 127 with basic baud rates stop and parity bits. The protocol is referred to as Whessmatic 550, which was widely used by the UK for their Intelligent Tang gauging systems. The ATT meets and exceeds the requirements of the Whessmatic 550 format because of its redundant dual port capabilities, and the bipolar signal circuitry design. The advanced circuitry allows the ATT to communicate without error at 9600 baud through 2 data ports simultaneously. A typical transmitter using current loop signal format nominally communicates at 300 to 1200 baud at maximum.

10.6 4000GMFMO

Basically this is identical to the standard release of the 400048FMO, a MODBUS protocol device communicating over RS-485 data lines. GSI, a tank gauging systems manufacturer has re-mapped level and temperature integer registers to non-standard MODBUS locations. This version ATT allows it to co-exist along side GSI transmitters and gauging systems with response data as expected.

Glossary

Adv Hi Level

Advisory High Level alarm set point. When the product level exceeds this point an advisory alarm will be generated.

Adv Hi Temp

Advisory High Temperature alarm set point. When the product temperature exceeds this point an advisory alarm will be generated.

Adv Lo Level

Advisory Low Level alarm set point. When the product level drops below this point an advisory alarm will be generated.

Adv Lo Temp

Advisory Low Temperature alarm set point. When the product temperature drops below this point an advisory alarm will be generated.

Adv Rtd Level

Advisory Resistive Temperature Device Level. Height of the RTD in the tank. An alarm is generated when the level goes below this level (temperature measurements can no longer be made).

Advisory Alarms

Process alarms intended to act as caution indicators providing users advanced warnings of unusual situations.

ATT

Varec Model 4000 Advanced Technology Transmitter.

ATTI Bus

Unpowered, non-intrinsically safe, HART compatible communication bus used on ATT.

Baud Rate

A communications measure of serial data transmission rate typically in bits per second. Normal baud rates for RS-232 interfaces are 300, 1200, 2400, 4800, 9600, 19200. The higher the baud rate, the faster the data transfer occurs across the data line.

Comm Port

Communication Port. An access point for data entry or exit.

Crit Hi Level

Critical High Level alarm set point. When the product level exceeds this point a critical alarm is generated.

Crit Hi Temp

Critical High Temperature alarm set point. When the product temperature exceeds this point a critical alarm is generated.

Crit Lo Level

Critical Low Level alarm set point. When the product level drops below this point a critical alarm is generated.

Crit Lo Temp

Critical Low Temperature alarm set point. When the product temperature drops below this point a critical alarm is generated.

°C

Celsius. A unit of measure for temperature readings. 0 °C is the freezing point for water, 100 °C is the boiling point of water.

DBAND

Deadband.

ft-in-16

Feet-inches-1/16 of an inch. Imperial fractional measurement.

oF

Fahrenheit. A unit of measure for temperature readings. $0\text{ }^{\circ}\text{C} = 32\text{ }^{\circ}\text{F}$. A temperature of $32\text{ }^{\circ}\text{F}$ is the freezing point of water, $212\text{ }^{\circ}\text{F}$ is the boiling point of water.

Host

A tank data acquisition system responsible for collecting and processing information from a number of subordinate devices.

IEEE

Institute of Electrical and Electronic Engineers. A trade organization that provides publications, educational information, and standards that are widely used.

IEEE 754

A floating point data format.

oK

Kelvin. A unit of measure for temperature readings typically applied to the measurement of liquefied gases. $0\text{ }^{\circ}\text{C} = 273.16\text{ }^{\circ}\text{K}$. The freezing point of water is 273.16 oK , the boiling point is 373.16 oK .

Level Dband

Level Deadband. The band that a level alarm must clear before the alarm is reset.

Level

Level of product in a tank.

Manual Temp

A product temperature specified and entered by the user instead of being obtained from a sensor.

MHz

Megahertz, also called megacycles. One million electronic cycles per second, a unit of electronic frequency.

Parity

A setup parameter used with serial data communications.

RTD

Resistive Temperature Device. A metal probe used to measure temperature.

Serial Ports

A hardware interface used for serial data communications.

Stop Bits

A setup parameter for serial data communication.

Temp Dband

Temperature Deadband. The band that a temperature alarm must clear before the alarm is reset.

Temp

Temperature.

TSU

Tank Polling Unit. A Varec interface unit that allows a host computer to interface to Varec Mark/Space, Remote Selector, IFU, and Matrix field interfaces.

NOTES

Your official representative

Varec[®]



www.varec.com

Varec, Inc.
5834 Peachtree Corners East, Norcross (Atlanta), GA 30092 USA
Tel: +1 (770) 447-9202 Fax: +1 (770) 662-8939

© 2004 Varec, Inc. All Rights Reserved. This document is for information purposes only. Varec, Inc. makes no warranties, express or implied, in this summary. The names of actual companies and products mentioned herien may be the trademarks of their respective owners.