

TS-RDS5W

USB2.0 Portable Card Reader

Description

TS-RDS5W is a USB2.0 Portable SD/MMC Card Reader. It is a small and thin device specifically designed for fast, easy data transfer and exchange using multiple types of Memory Cards.

Features

- Color: White
- Fully Compliant with the Hi-Speed USB 2.0 specification
- Hi-Speed Data transfer rates of up to 480Mb/s
- USB powered (no external power or battery needed)
- LED indicates card insertion and data traffic
- Compatible Cards :

Directly:

- SD (Secure Digital)
- SDHC (Secure Digital High Capacity)
- MMC (MultiMediaCard)
- MMCplus
- MMCmobile
- RS-MMC

Adapter Required :

- miniSD
- miniSDHC
- microSDHC
- microSD / TransFlash
- MMCmicro

Placement

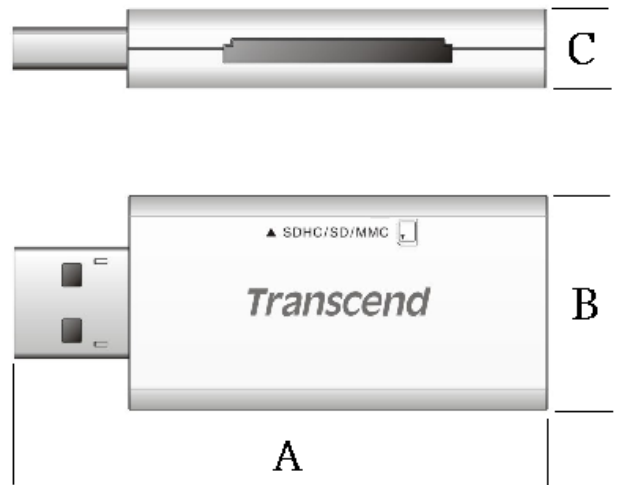

Dimensions

Side	Millimeters	Inches
A	57.90 ± 1.0	2.28 ± 0.04
B	23.20 ± 1.0	0.91 ± 0.04
C	7.60 ± 1.0	0.30 ± 0.04

System Requirements

- Desktop or notebook computer with a working USB port
- One of the following Operating Systems:
 - Windows® Me
 - Windows® 2000
 - Windows® XP
 - Windows Vista™
 - Mac™ OS 9.x, or later
 - Linux™ Kernel 2.4.2, or later

TS-RDS5W

USB2.0 Portable Card Reader

Pinouts

Pin No.	Pin Name
01	V _{USB}
02	USB-
03	USB+
04	VSS

Pin Identification

Symbol	Function
USB-	USB differential signal: The pairs are used to transmit Data/Address/Command
USB+	
VSS	Ground
V _{USB}	USB Power Input

Block Diagram

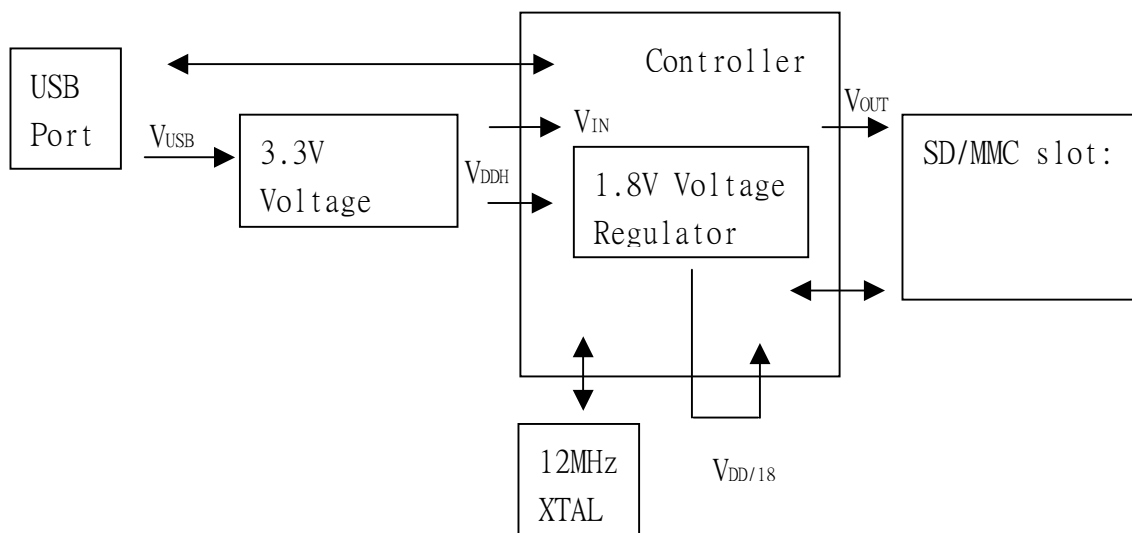

Absolute Maximum Ratings

SYMBOL	PARAMETER	RATING	UNITS
V_{DDH}	Power Supply	-0.3 to $V_{DDH}+0.3$	V
V_{IN}	Input Voltage	-0.3 to 3.6	V
V_{OUT}	Output Voltage	-0.3 to $V_{DDH}+0.3$	V
T_{STG}	Storage	-40 to 150	°C

Recommended Operating Conditions

SYMBOL	PARAMETER	MIN	TYP	MAX	UNITS
V_{DDH}	Power Supply	3.0	3.3	3.6	V
$V_{DD/18}$	Digital Supply	1.62	1.8	1.98	V
V_{IN}	Input Voltage	0	3.3	3.6	V
T_{OPR}	Operating	0		70	°C

DC Characteristics:

SYMBOL	PARAMETER	CONDITIONS	MIN	TYP	MAX	UNITS
I_{IN}	Input current	no pull-up or pull-down	-10	± 1	10	μA
I_{OZ}	Tri-state leakage current		-10	± 1	10	μA
C_{IN}	Input capacitance	Pad Limit		2.8		ρF
C_{OUT}	Output capacitance	Pad Limit		2.8		ρF
C_{BID}	Bi-directional buffer capacitance	Pad Limit		2.8		ρF

Above technical information is based on industry standard data and tested to be reliable. However, Transcend makes no warranty, either expressed or implied, as to its accuracy and assumes no liability in connection with the use of this product. Transcend reserves the right to make changes in specifications at any time without prior notice.