

8900NET

NETWORK INTERFACE MODULE

Instruction Manual

SOFTWARE VERSION 3.2.0

071061202
JUNE 2003

the most watched worldwide

Contacting Grass Valley

Region	Voice	Fax	Address	Web Site
North America	(800) 547-8949 Support: 530-478-4148	Sales: (530) 478-3347 Support: (530) 478-3181	Grass Valley P.O. Box 599000 Nevada City, CA 95959-7900 USA	www.thomsongrassvalley.com
Pacific Operations	+852-2585-6688 Support: 852-2585-6579	+852-2802-2996		
U.K., Europe, Asia, Middle East	+44 1753 218 777	+44 1753 218 757		
France	+33 1 45 29 73 00			
Germany	+49 221 1791 234	+49 221 1791 235		

Copyright © Thomson Broadcast and Media Solutions All rights reserved.

Grass Valley Web Site

The www.thomsongrassvalley.com web site offers the following:

Online User Documentation — Current versions of product catalogs, brochures, data sheets, ordering guides, planning guides, manuals, and release notes in .pdf format can be downloaded.

FAQ Database — Solutions to problems and troubleshooting efforts can be found by searching our Frequently Asked Questions (FAQ) database.

Software Downloads — Software updates, drivers, and patches can be downloaded.

Contents

- Preface**..... 5
 - About This Manual..... 5

- 8900NET Network Interface Module**
 - Introduction..... 7
 - 8900NET Features..... 7
 - Remote Control Panel..... 8
 - Basic Network Design..... 8
 - Installation..... 9
 - Module Placement in the Gecko 8900 Frame..... 9
 - Cabling..... 11
 - Frame Alarm..... 11
 - RS-232 Communication Port Cable..... 11
 - Ethernet Cable..... 14
 - Power Up..... 16
 - Monitor Module Indicator LEDs..... 17
 - Enabling Alarms and Fan Speed Control Option..... 18
 - Establishing Frame Network Identity..... 19
 - NetConfig Application..... 19
 - Good Networking Practices..... 19
 - Setting Frame Network Identity..... 20
 - Network Configuration Storage..... 22
 - Web Browser Setup..... 22
 - Web Browser Notes..... 23
 - Addressing the Frame URL..... 23
 - Default MAC (machine) Address..... 23
 - Using the 8900NET GUI..... 24
 - 8900 Frame Interface..... 24
 - Frame Status Page..... 24
 - Older and Legacy Module Support..... 26
 - Frame Configuration Page..... 28
 - 8900NET Module Interface..... 29
 - Viewing Network Module Status..... 29
 - Network Module Configuration for SNMP..... 30
 - SNMP Agent Installation..... 30
 - SNMP Report Activation..... 33
 - Media Module Slot Configuration..... 34
 - Locate Module..... 34
 - Slot Identification..... 34
 - Hardware Switch Controls..... 35
 - Slot SNMP Trap Reports..... 35
 - Module ID and Network Parameters..... 35
 - Rebooting the NET Module..... 36

Updating Software	37
Overview	37
Software Update Procedure.	38
Specifications.	53
Service	54
Troubleshooting GUI Operation	54
Functional Description	62
Temperature Sensing	62
ROM and RAM.	63
Ethernet Port	63
RS-232 Serial Port	63
Module Health Bus.	63
Frame Bus.	63
Module Present Detection	63
Fan Speed Control and Monitor.	64
On-board Regulator	64
Appendix	65
Compatibility Matrix	65
Control and Monitoring Support	67
Control and Monitoring Notes	67
8900-FLOAD-CBL Assembly	67
Index	69

Preface

About This Manual

This manual describes the features of a specific 8900 module in the Gecko Signal Processing System family. As part of this module family, it is subject to Safety and Regulatory Compliance described in the Gecko 8900 Series frame and power supply documentation (see the *Gecko 8900 Frames Instruction Manual*).

8900NET Network Interface Module

Introduction

The 8900 Network Interface module (8900NET) is designed to operate in all Gecko 8900 Signal Processing frame versions.

Note The 8900TX-V/-A frame must be upgraded to a TF-V/-A frame (with fans) before installing an 8900NET module.

The 8900NET module provides control and monitor access to the frame and its audio/video modules through a web browser graphical user interface (GUI). The 8900NET enables remote configuration and monitoring of the enhanced Gecko 8900 frame and its remote control capable modules.

8900NET Features

The 8900NET module features:

- 10 Base-T Ethernet interface,
- HTML protocol support,
- Fan front cover power and control,
- Frame health monitoring,
- Software update downloading support,
- Support for the Newton Modular Control system control panels,
- Support for Frame Alarm,
- Support for Simple Network Management Protocol (SNMP) monitoring, and
- Support for NetConfig application.

Remote Control Panel

The 8900NET module with version 2.1 or later software allows the frame to be remotely controlled by external control panels. These panels are connected via the Ethernet port. Refer to the control panel documentation for details.

Basic Network Design

The 8900NET module can be employed in either a point-to-point or local area network (LAN) control/monitoring configuration. Figure 1 illustrates a point-to-point configuration.

Figure 1. Point-to-point Configuration

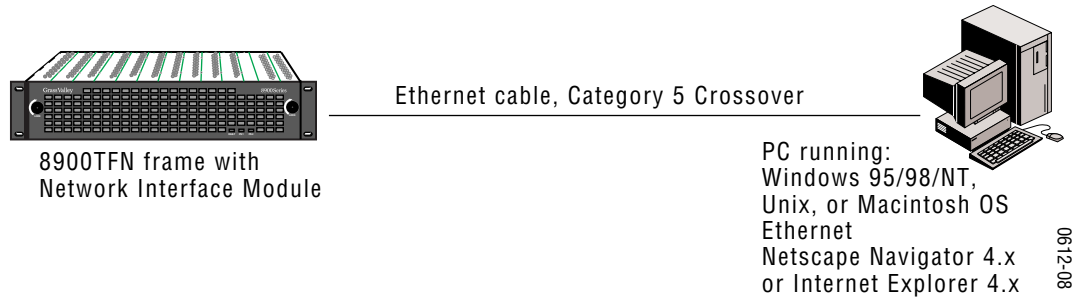
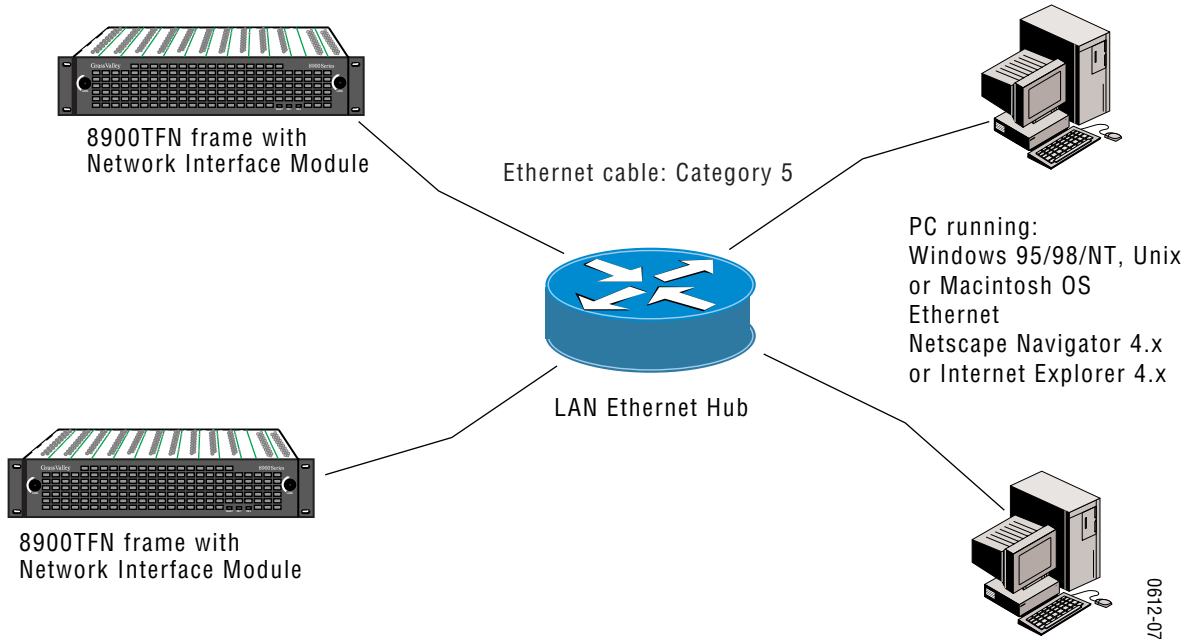

Figure 2 illustrates a typical LAN configuration.

Figure 2. Basic Network Configuration



Installation

This section describes placing the module in the Gecko 8900 frame and cabling the communications ports. Procedures for power-up, DIP switch settings, and network configuration of the module are described in following sections.

Module Placement in the Gecko 8900 Frame

There are ten cell locations in the frame to accommodate either analog or digital modules. These are the left ten locations. Refer to [Figure 3](#).

The two cells on the right are allocated for the power supplies. For additional information concerning the Power Supply module, refer to the *8900 Series Frames Instruction Manual*.

The third cell from the right is allocated for the 8900NET Network Interface or Frame Monitor module. For additional information concerning the Frame Monitor module, refer to the *Gecko 8900 Series Frames Instruction Manual*.

Figure 3. 8900 Series Frame

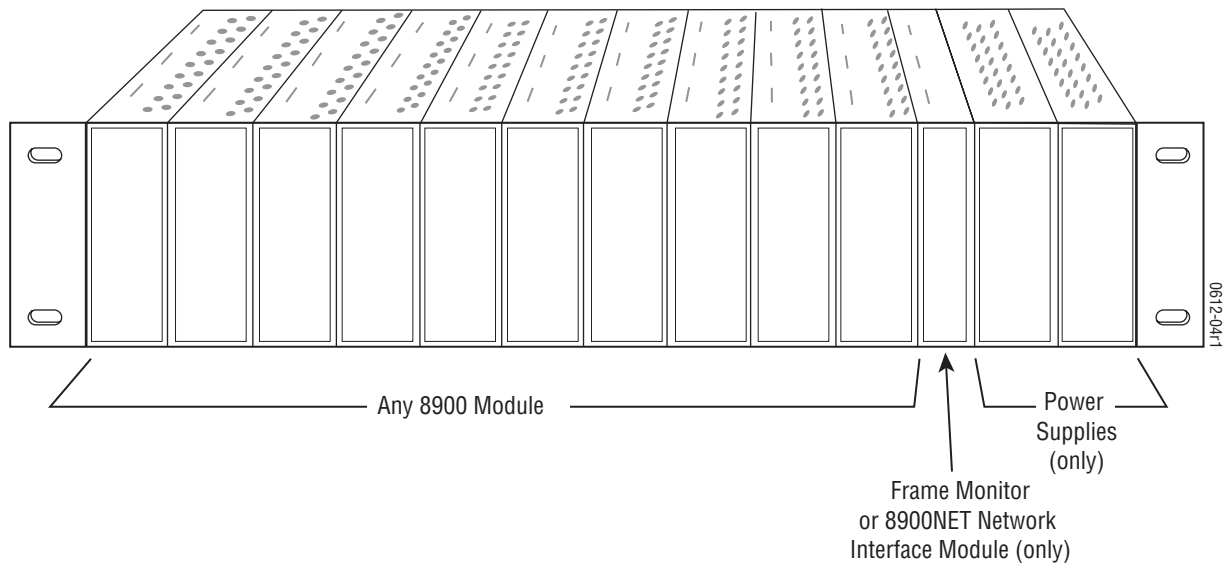

Note The 8900NET module can be plugged in and removed from a Gecko 8900 Series frame with power on. When power is applied to the module, LED indicators reflect the initialization process (see [Power Up on page 16](#)).

To install the 8900NET module in the frame:

1. Insert the module, connector end first (see [Figure 4](#)), with the component side of the module facing to the right side of the frame. Instead of an ejector tab, the 8900NET module has a connector tab with a circular finger-hole for pulling the module.
2. Verify that the module connector seats properly and securely against the backplane.

Figure 4. Module/Frame Orientation

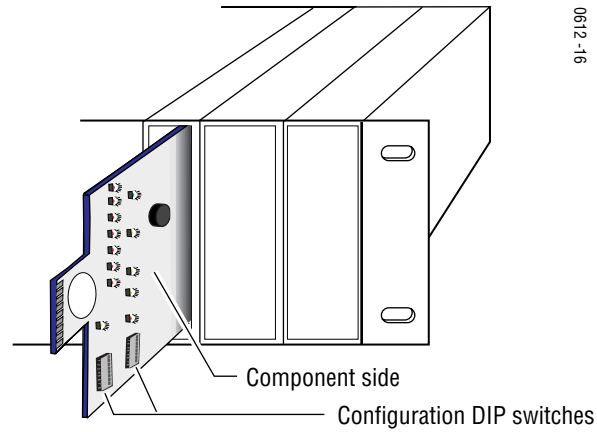

Cabling

This section describes physical connections, the connectors and cables, used for network communications. Setup procedures for each type of connection are described in *Establishing Frame Network Identity* on page 19.

An example of control and monitoring connectors on the 8900TFN frame are illustrated in Figure 5.

Note There are several versions of frames in the Gecko 8900 Series. Refer to the 8900 Series Frames manual that came with your frame for the latest information on cabling.

Figure 5. 8900NET Input/Output Connectors on 8900TFN Frame

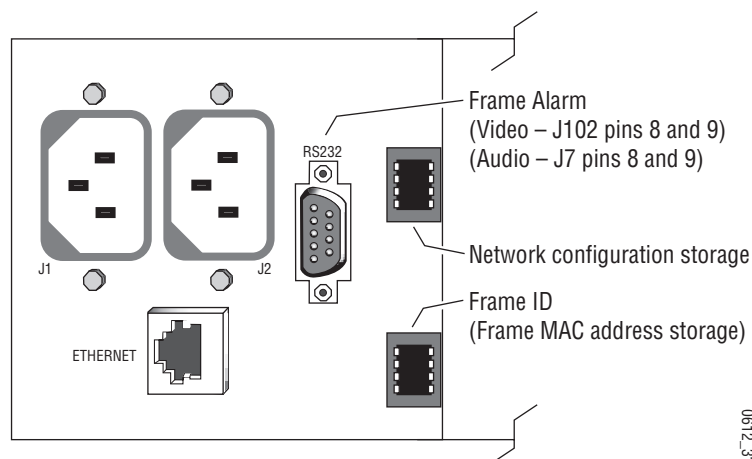

Frame Alarm

The Frame Alarm is accessed through pins 8 and 9 of the RS-232 connector. Details for connecting an external customer-supplied alarm are given in the *Gecko 8900 Series Frames Instruction Manual*.

Note Earlier version 8900 frames used a BNC connector labelled SMPTE ALARM to access the alarm connection. For information concerning the SMPTE Alarm bus cable, refer to the *Gecko 8900 Frames Instruction Manual*.

RS-232 Communication Port Cable

The nine-pin RS-232 connector is used to connect the frame to a PC to initially set the frame's network communication parameters. After network communication is established, subsequent changes to these parameters can be made using the network GUI.

CAUTION The RS-232 cable should be removed after completing the initial frame setup. Leaving a long serial cable connected to the frame without a connection at the other end may freeze the 8900NET module startup routine.

Note The cable used for this connection is a DB-9F to DB-9M, straight-through cable available from Grass Valley as part of cable kit model 8900CAB (10 ft./ 3 m length).

The communication parameters for the RS-232 connection are:

- Baud rate: 9600
- Data bits: 8
- Parity: none
- Stop bits: 1
- Flow control: none

The male end connects to J102–Video/BNC or J7–Audio RS-232 connector on the 8900 TFN frame (see Figure 6) and the female end connects to either Com1 or Com2 on the PC, depending upon the configuration of the computer’s I/O ports.

Figure 6. RS-232 to Initialization PC Cable and Pinout

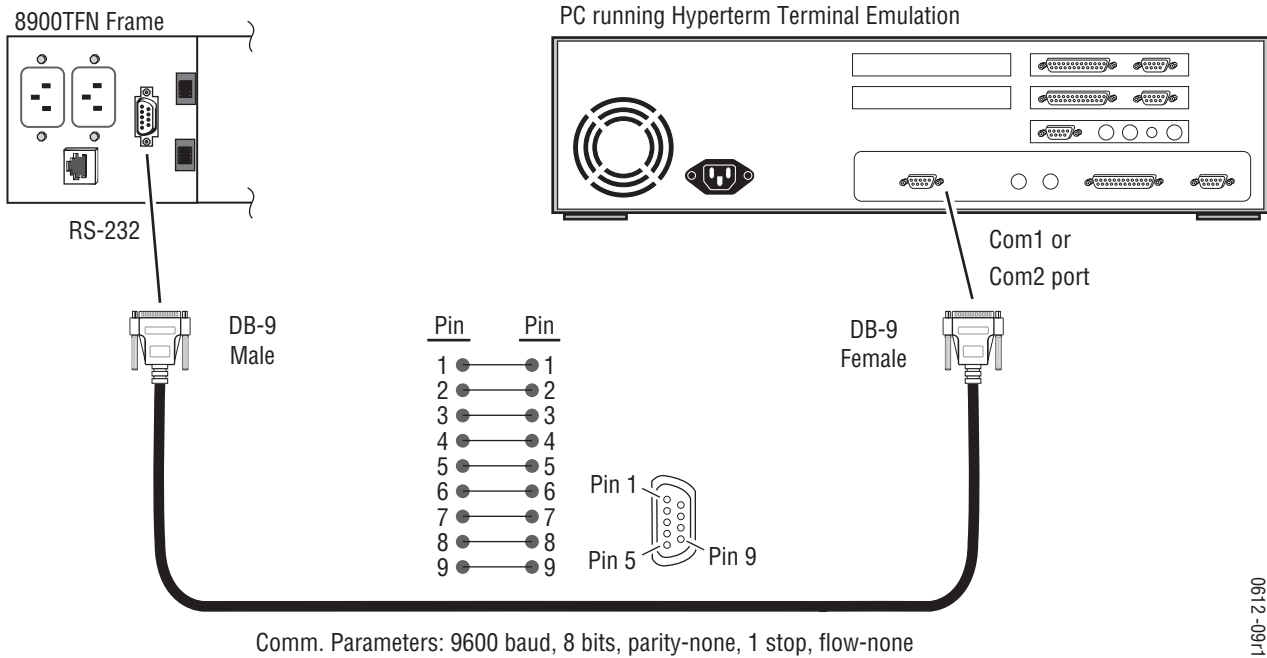

0612-09/1

If the PC uses a 25-pin RS-232 connector, use a cable adapter as shown in Figure 7.

Note The 25-pin adaptor is available from Grass Valley as part of cable kit model 8900CAB.

Figure 7. DB-9 Cable and DB-25 Cable Adaptor Pinout

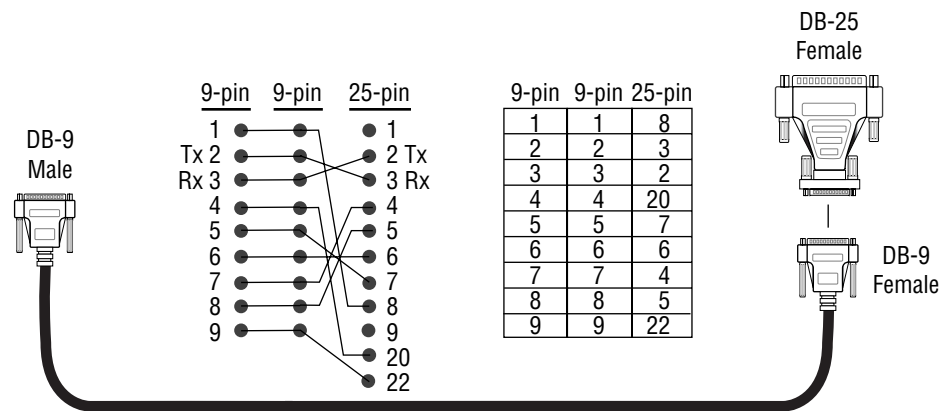

0612-11

Ethernet Cable

The 8900NET module enables the frame's RJ-45 Ethernet connector. Through this port the 8900 frame can connect to:

- A single PC with a network card (point-to-point), or
- A local area network (LAN) through a network hub.

Point-to-Point Connection

Figure 8 illustrates the crossover cable connection and pinout for a point-to-point connection to the controlling PC.

Note This Category 5, UTP Crossover Cable is available from Grass Valley as part of cable kit model 8900CAB (10 ft./3 m length).

Figure 8. Point-to-Point RJ-45 Connection and Cable Pinout

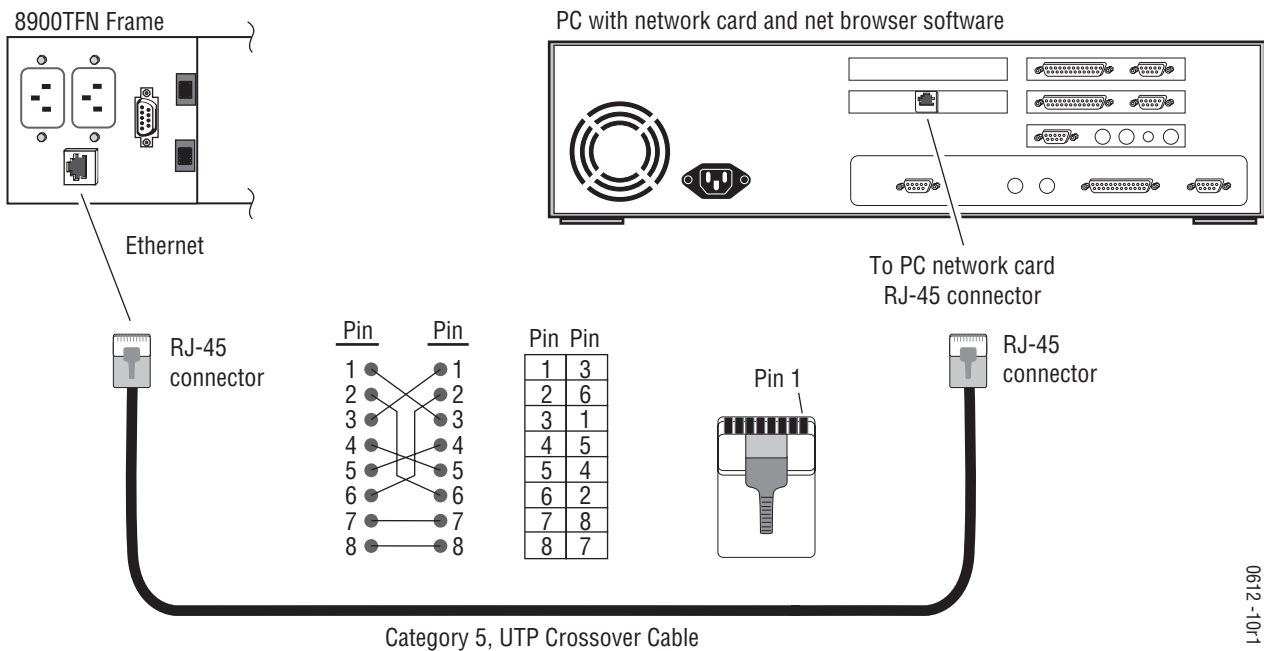

0612-10r1

Local Area Network (LAN) Connection

Figure 9 illustrates the cable connection for a LAN connection to a network hub.

Note Because of varying length requirements and ready availability from network equipment suppliers, this cable is not supplied by Grass Valley.

Figure 9. LAN RJ-45 Connection and Cable

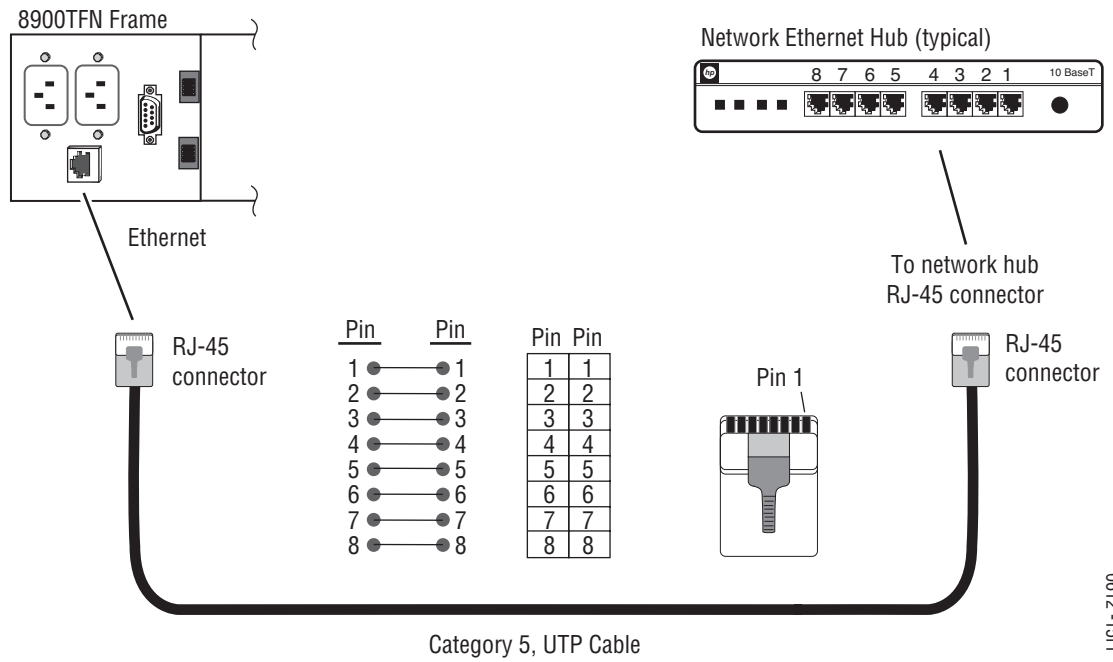

0612-15r1

Power Up

The various front LED indicators and configuration switches are illustrated in Figure 10. Upon power-up, all LEDs should light for the duration of the initialization process. After initialization the Power LED will be on and the red Network Module LED (labeled NM) should go off. All other LEDs report detected conditions within the frame and the installed modules. If the NM LED does not go off, the board needs servicing.

Figure 10. LEDs and Configuration Switches

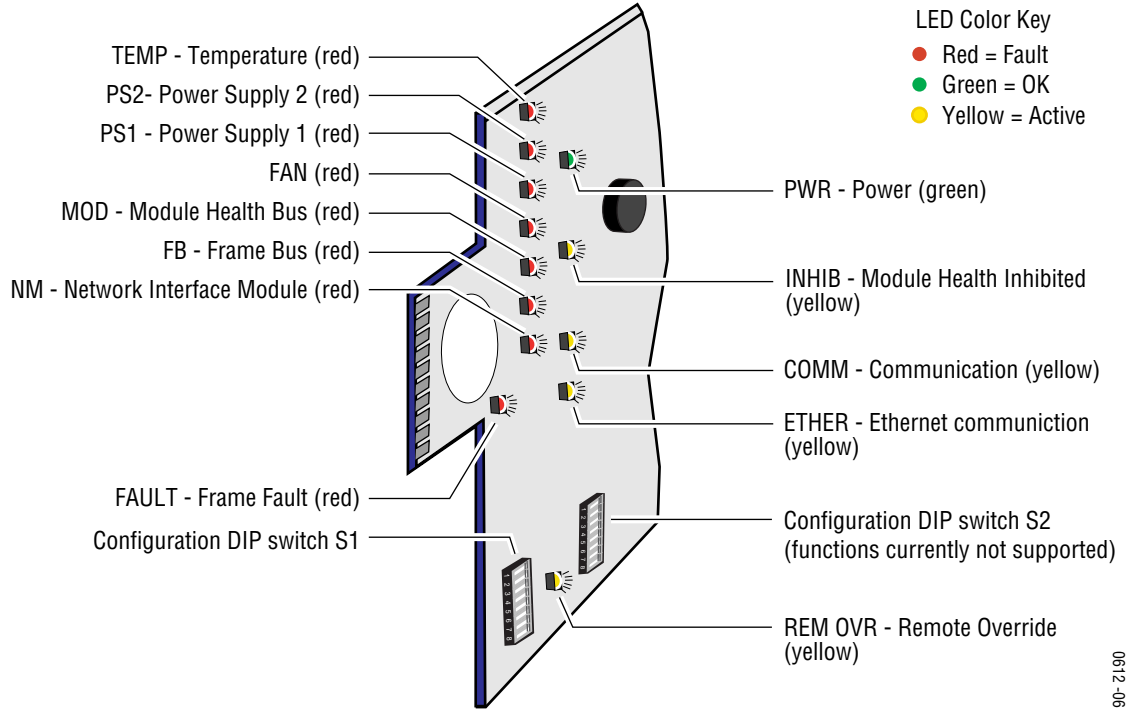

Table 1 on page 17 describes all the module's LEDs and the conditions indicated.

Monitor Module Indicator LEDs

The possible LED status and conditions indicated are shown in [Table 1](#).

Table 1. Indicator LEDs and Conditions Indicated

LED	LED State	Condition
POWER (green)	Off	Power is off or on-board regulator has failed
	On continuously	Module is powered
TEMP (red)	Off	Frame temperature is within specified parameters
	On continuously	Over-temperature condition detected in frame
PS2 (red)	Off	Normal operation or alarm disabled
	On continuously	Power supply 2 is present and reporting an alarm condition
PS1 (red)	Off	Normal operation or alarm disabled
	On continuously	Power supply 1 is present and reporting an alarm condition
FAN (red)	Off	Normal operation or alarm disabled
	On continuously	One or more fans in the front cover assembly is not rotating
MOD (red)	Off	Normal operation or alarm disabled
	On continuously	Module health bus is not disabled and one or more modules is reporting an internal fault
	Long continuous flashing	One or more modules is reporting a configuration error
FB (red)	Off	Network module is communicating with modules on the frame bus
	On	Internal frame bus communication failure
INHIB (yellow)	Off	Normal operation or alarm disabled
	On continuously	A non-compliant module in the frame has disabled the module health bus
FAULT (red)	Off	Normal operation
	On continuously	One of the on-board fault LEDs is illuminated or flashing
	Flashing	Indicates the MOD (module health LED) is flashing
COMM (yellow)	On	Indicates module is polling the devices on the internal frame communication bus
ETHER (yellow)	On	Indicates active communication detected on the Ethernet bus
REM OVR (yellow)	Off	All fault reporting is controlled by onboard configuration switches
	On	Software overrides onboard configuration switches

Enabling Alarms and Fan Speed Control Option

The 8900NET module has two eight-position DIP switches (S1 and S2) that enable or disable the fault reporting functions and the variable fan speed option (see Figure 11). Enabled fault alarms drive on-board LEDs and can also be sent to SNMP monitoring stations when the SNMP network and Agent software has been installed and configured (see *Network Module Configuration for SNMP* on page 30).

Figure 11. Alarm Reporting DIP switches

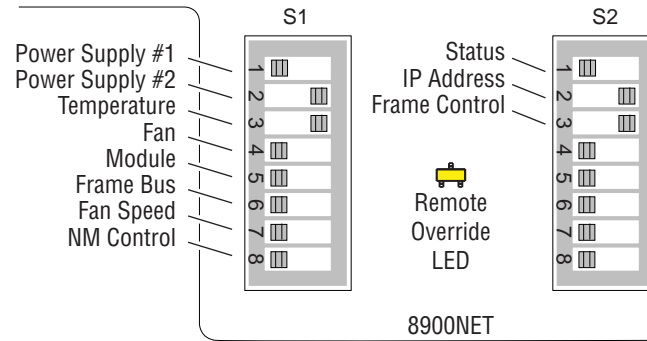

Disabling (or filtering) specific fault alarms can be useful in isolating problems in the frame. Refer to Table 2 for the possible settings. A settings table is also silk-screened on the module.

Table 2. Configuration DIP Switch Settings

S1 Segment	Left Position (open)	Right Position (closed)
1	PS1 Fault Reporting Enabled	PS1 Fault Reporting Disabled
2	PS2 Fault Reporting Enabled	PS2 Fault Reporting Disabled
3	(Not used) Over Temp reporting is always enabled locally and through SNMP	
4	Fan Fault Reporting Enabled	Fan Fault Reporting Disabled
5	Module Fault Reporting Enabled	Module Fault Reporting Disabled
6	Frame Bus Error Reporting Enabled	Frame Bus Error Reporting Disabled
7	Fan Speed Controlled by Temperature	Fan Speed Fixed at Maximum
8	Network Module Control Enabled (remote control via GUI is enabled)	Network Module GUI is placed in read only mode
S2 Segment	Left Position (open)	Right Position (closed)
1	Status Enabled (enabled alarms are reported over SNMP)	SNMP Reporting is disabled except for Over Temp alarm
2	IP Address (not currently supported)	
3	Frame Control Enabled (remote control via GUI is enabled)	GUI for the frame and all modules within is placed in read only mode
4 – 8	(Currently Not Used)	

Establishing Frame Network Identity

The initial configuration of the 8900NET module, using the RS-232 port (refer to [Figure 6 on page 12](#)), establishes the frame's network identity to enable the operation of the Web-based GUI. A PC running a terminal emulation application is used to set the initial parameters for network communication. Once initial identity is established, the GUI can be used to make subsequent changes to the networking parameters. Parameters established include:

- Local IP Address,
- Gateway IP Address,
- Subnet Mask, and
- Default Route.

Note If the Gecko 8900 frame is to be connected point-to-point to a single PC workstation, both the frame and the PC must be on the same Subnet.

NetConfig Application

With this software release, Gecko 8900 Series frames can interface with NetConfig (Network Configuration Application). NetConfig is a PC software tool for configuring and setting up NetConfig-enabled Grass Valley devices. Refer to the NetConfig Manual or the 8900NET Release Notes for current information on using this tool.

Good Networking Practices

The Local IP Address form of a URL can be used within an intranet to address the Gecko 8900 frame's web page. An intranet is set up and maintained within your facility and is isolated from the Internet.

Access from outside, through the Internet, may require the use of a Domain Name and a firewall, depending upon your network architecture. Domain Name Addressing requires a Domain Name Server located within the intranet that maps the Domain Name to the frame's IP Address. The 8900TFN frame has no knowledge of its assigned Domain Name. Network traffic through a Domain Name Server can delay 8900NET response time.

Remote workstations are also subject to network traffic delays. Local PC workstations should be used for real-time operation of the 8900NET.

The most direct and timely access to the frame is achieved by using a PC workstation that is assigned to the same Subnet (see [Figure 12](#)). A workstation in a different Subnet, even when located on the same router, will be subject to processing of the IP Gateway.

Figure 12. Local IP and Subnet Addressing

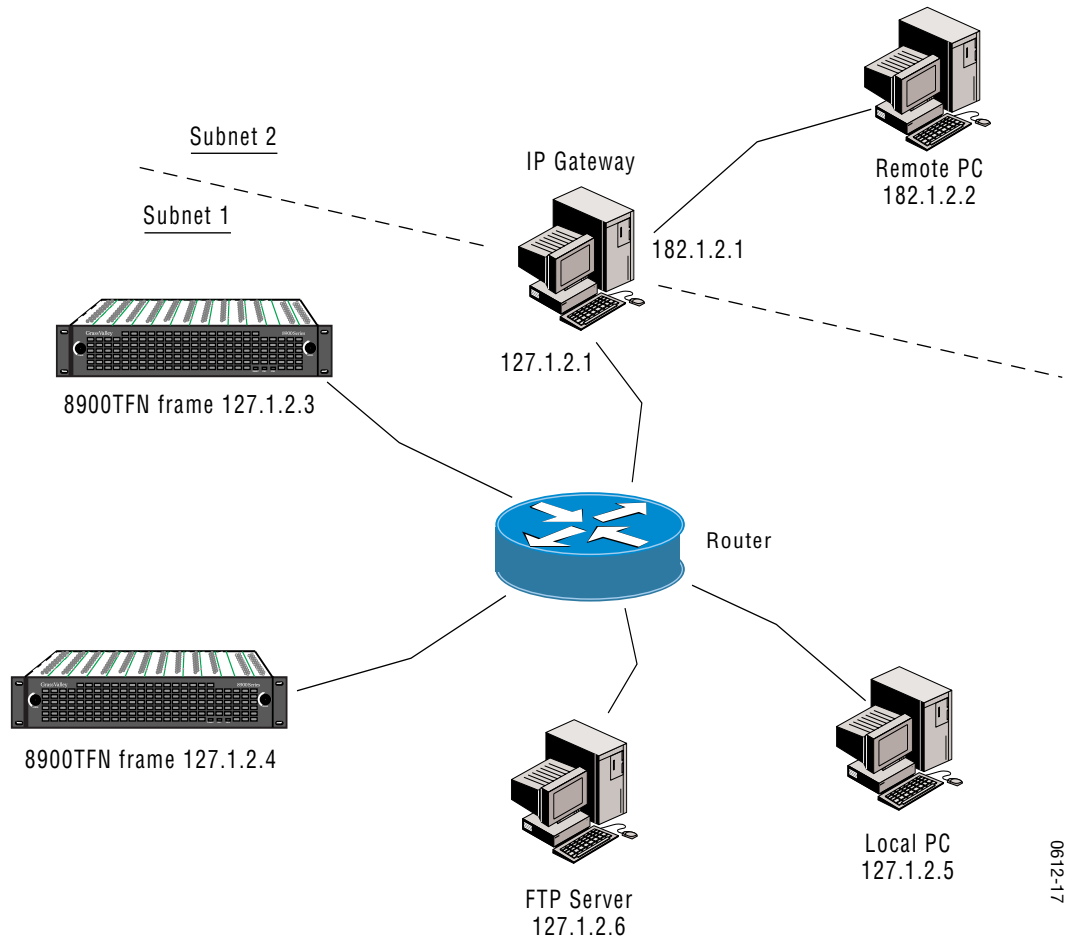

0612-17

Setting Frame Network Identity

After you have connected the PC to the RS-232 port (refer to [RS-232 Communication Port Cable](#) on page 11) and established communication using the terminal emulation application, press the enter/return key several times to see the active prompt.

At the prompt enter:

```
setup
```

You will see:

```
-> setup
```

Here are the current parameters and their values:

```
Local IP Address:      192.158.211.83
Gateway IP Address:   192.158.211.1
Subnet Mask:          255.255.255.0
```

If a change is made, it is necessary to reboot this machine. This will occur automatically when you have completed making changes.

Do you wish to change any of the values? y/n (n): y

For each parameter, you will be given the name of the parameter and its current value in parenthesis. To change it, just type in the new value. If you don't wish to change it, just hit the Enter key.

If you make a mistake on a previous value, continue with the remaining parameters; you will be given an opportunity to modify the value again.

Please ensure that you change from Factory defaults to your network parameters.

The local Ip Address is the Internet address of this machine. It consists of four numbers separated by periods ('.'). Each number can be in the range of 0 to 255. For example: 192.167.221.45
There must an IP address.

IP Address (192.158.211.83):

The Default Route is the Internet address of the machine which routes network packets outside of the local network. It consists of four numbers separated by periods ('.').

Each number can be in the range of 0 to 255.

For example: 192.167.221.1

If you respond with a single period (.), a default route will not be assigned.

Default Route (192.158.211.1):

The Subnet Mask is used in the routing algorithm. The Net Card will use the mask to determine if a address is in local net or to send the message to the default. It consists of four numbers separated by periods ('.').

Each number can be in the range of 0 to 255.

For example: 192.167.221.1

If you respond with a single period (.), a Subnet Mask will not be assigned.

Subnet Mask (255.255.255.0):

Network Configuration Storage

8900NET software version 3.0.0 and later enables storage of the IP addresses (network configuration) on the frame backplane on frames that are equipped with storage capability (see [Figure 5 on page 11](#)). In earlier versions of software and frame types with no storage capacity, the IP addresses are stored on the 8900NET module and stay with the module when it is moved to another frame.

There are a number of ways to determine what type of frame you have. [Table 3](#) lists all available frame types and how they can be identified. The assembly number of the frame is identified on a label located inside the frame inside the chassis.

Table 3. 8900 Frames Types IP Storage Capability

Model Number	Backplane	Assembly Number	Network Config Storage
8900TFN-A	Audio backplane with 1 IC	610-0960-00	8900NET module
8900TFN	Video backplane with 1 IC	630-0063-00	8900NET module
8900TFN-A	Audio backplane with 2 ICs	610-0960-01	Frame backplane
8900TFN-V	Video backplane with 2 ICs	610-0984-00	Frame backplane

To determine what frame model you have and where IP addresses are stored, you may also access the Frame Status page with the web browser (see [Figure 16 on page 29](#)). All frames with 8900NET cards with software version 3.0.0 and later will report a **Network Config** status message as one of the following:

- Network configuration stored on 8900NET module, or
- Network configuration stored on frame.

Web Browser Setup

The recommended Web browser for use with the 8900NET Control and Monitoring System is either:

- Netscape Navigator 4.x or later, or
- Internet Explorer 4.x or later.

Versions 3.x or earlier of these browsers may cause undesirable results in the presentation of HTML frames.

Web Browser Notes

- If applicable, configure the browser for direct HTTP requests to the frame rather than addressing a Proxy Web Server. The Modular Frame Web Server will typically be installed inside the firewall.
- For older Netscape browsers, the Cache should be configured to always refresh.

Addressing the Frame URL

To address an 8900TFN frame from an internet browser, enter the frame's default URL into the URL line of the browser ("Location" in Netscape Navigator, "Address" in Internet Explorer). The URL will be the IP Address given to the frame during initial setup (see [Setting Frame Network Identity on page 20](#)), or a Domain name that has been mapped to the IP Address in your Domain Name Server tables. The URL should look like this:

`http://{Frame's IP Address}/`

Example:

`http://127.123.234.2/`

Or:

`http://{Frame's Domain Name}/`

Example:

`http://frame1.xyz.com/`

The correctly entered URL will call up the 8900 frame's default first page—Frame Status.

Default MAC (machine) Address

Each 8900TFN frame has a unique ethernet physical level MAC address that is stored in the frame ID memory chip (see [Figure 5 on page 11](#)). If this memory is missing, the 8900NET module will substitute a default MAC address: 08-00-11-09-CD-AB. If more than one 8900 frame in your network is assigned the default MAC address, network conflicts will occur. To verify the frame has a unique MAC address refer to [Module ID and Network Parameters on page 35](#).

Using the 8900NET GUI

Once the frame's first page—Frame Status—has been accessed (see [Figure 13 on page 25](#)), navigation can be done using the hypertext Link List in the left column.

The Link List is a two-tier list with the frame's devices at the highest tier and sub-pages for each device in a secondary tier (sub-list) below the parent device.

To navigate from device to device, click on a device link. This will open the device's status page and open the sub-list of device pages. You can also click on the slot icon in the content display to access a particular module's status page.

To navigate to one of the device's pages click on any of the device's sub-list of links. This will update the content display to the right.

Note To update status, html pages must be manually refreshed by clicking on the **Refresh** button (to the right of the page title). Changes made at the frame or from other browsers on the network will not be displayed until the page is refreshed.

8900 Frame Interface

This section describes GUI functions for the 8900 frame.

Frame Status Page

The Frame Status Page ([Figure 13 on page 25](#)) displays an overall status for the frame.

The top section reports the following for the frame:

- Model Number,
- Description,
- Frame Location (set in Frame Configuration),
- Temperature Status,
- Warning messages, and
- Front Cover status (Cover installed, No Cover)

The graphical content display shows:

- Module slot status,
- Power supplies installed (and empty slots),
- Presence of the 8900NET module (Net Card), and
- A clickable link to each device's status page.

Figure 13. 8900NET GUI for Frame Control

The Links section lists the frame and its current modules. The selected link's Status page is first displayed and the sub-list of links for the selection is opened. The sub-list allows you to select a particular information page for the selected device.

Content display section displays the information page for the selected frame or module (frame slot icons are also active links).

Refresh button for manual refresh of page

Online Manual Link

Status

Model: 8900TFN Description: Module Frame
 Frame Location: Grass Valley
 Temperature Status Pass
WARNING - Module Data or Config Errors

Empty	Empty	Module	Empty	Module	Empty	Empty	Empty	Empty	Empty	Empty	Net Card	Empty	Power Supply
-------	-------	--------	-------	--------	-------	-------	-------	-------	-------	-------	----------	-------	--------------

Front Cover No Cover

Properties

Vendor	Thomson, Grass Valley	Software Version	3.2.0
Media Slots	10	Network Config	Network configuration stored on 8900NET module

Module Slot Status

Module Slot Status icons report one of the following (Table 4):

Table 4. Module Status Indicators

Icon Color	Module Status	Icon Text	Indication
White	None	Empty	No module detected in slot.
Gray	No Comm	No Comm	Slot contains a legacy module which was not designed to support Frame Bus communications with an 8900NET module.
Green	Pass	Module	Slot contains a fully Frame Bus capable module.
Yellow	Warning	Module	8900NET has detected a warning condition in module due to lack of input signal or incomplete support for remote monitoring and control. Ability of module to perform intended operation is limited.
Red	Fault	Module	8900NET has detected a fault condition in module. Fault may have been communicated over the Frame Bus, or may indicate a failure of the module to respond over the Frame Bus.

During initial polling, modules that do not respond immediately may transition to a **WARNING, MODULE NOT RESPONDING** status. In this case, this is a temporary status until a maximum number of sequential attempts fail and a Fault is reported.

Note The first release of 8960DEC module code causes a Fault condition because it never responds on the Frame Bus. There is no way for the 8900NET module to tell the difference between a fully functional early release of 8900DEC and a module whose Frame Bus Interface has failed.

Note Early releases of the 8960ENC, 8950DAC, 8950ADC, 8920DAC, 8920ADC, and the 8916 signal a warning condition due to limited capability over the Frame Bus. All of these, except the 8916, can be upgraded by the user with fully capable Frame Bus software.

Frame Properties

The Properties section on the Frame Status page reports:

- Vendor name,
- Number of media module slots,
- Software version (installed on the 8900NET module),
- Network Config (whether the network configuration is stored on the 8900NET module or on the frame backplane, depending on frame model). Refer to [Network Configuration Storage on page 22](#).

Older and Legacy Module Support

8900 and legacy Grass Valley modules that can reside in the 8900TFN frame are supported to different degrees by the 8900NET module. A compatibility matrix describing the hardware versions, software update methods required, and remote control features of the various modules supported by the 8900 frames and 8900NET module is located in the [Compatibility Matrix on page 65](#).

Note When the 8900NET is first installed or when many modules are installed simultaneously, it may take some time for the 8900NET to poll, update status and build the HTML pages, especially if there are modules that do not respond as expected, such as legacy modules. During these periods the Frame Status Page may fall behind temporarily until the 8900NET board can catch up and present a true current status.

Legacy Module Support

Installation of 8500 and 8800 modules shipped prior to November 15, 1999 will cause interruption of the 8900TFN frame communication bus. Modules shipped after this date have pins removed in the rear connector to provide compatibility. Compatible modules can be identified by the absence of connector pins 10 and 50 (see Figure 14). Incompatible legacy modules can be returned to Grass Valley for upgrade to the new connector.

Note If an unmodified legacy module is installed in the frame, the frame communication bus will be interrupted and all module icons in the frame status display will be red. This problem occurs with legacy modules only and does not occur with Gecko 8900 Series modules.

Figure 14. Modified Legacy Module Connector

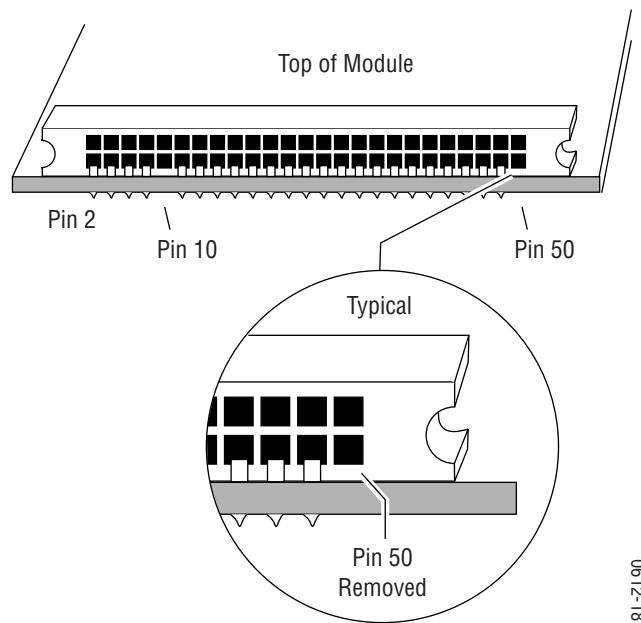

Frame Configuration Page

Use the Frame Configuration page shown in Figure 15 to:

- Activate the Locate Frame function,
- Save or recall a frame configuration to a default file,
- Assign the frame a name, index number, and location,
- Designate a Documentation Server Address for accessing user manuals in pdf format, and
- Enabling/disabling frame status reports for SNMP monitoring.

Figure 15. 8900 Frame Configuration Information

The screenshot shows the 'Configuration' page for a frame. It includes sections for 'Locate Frame', 'Save/Load Frame Configuration File', 'Frame Identification', and 'Frame SNMP Trap Reports'. Callouts provide instructions for each section.

Select Configuration
 Frame
 • Status
 • Configuration

Configuration
 Model: 8900TFN Description: Module Frame
 Frame Location: Modular Lab - Bay 1

Locate Frame
 Flash Off

To physically locate a frame, select and apply Flash to flash the frame's front cover LEDs

Save/Load Frame Configuration File
 Save to...
 Enter filename: Browse...
 Load

Save the current frame and slot configuration to a file
 Enter a path and filename to recall a saved frame configuration file
 Load the selected configuration file

Frame Identification
 Frame Name: Default
 Frame Index:
 Frame Location: Default
 Documentation Server Address:

Name the frame and its location. Enter an index number to be used in SNMP networking tables (not required)
 Enter IP Address for online manual server

Frame SNMP Trap Reports

	Frame Bus Status	Cover Status	Fan Status	Module Health
Enabled	<input checked="" type="checkbox"/>	<input checked="" type="checkbox"/>	<input checked="" type="checkbox"/>	<input checked="" type="checkbox"/>
Trap Severity	Alarm	Warning	Alarm	Alarm

Enable or disable the various status reports used in SNMP network monitoring system
 Note: To enable a report, on-board switches must also be enabled

8900NET Module Interface

This section describes GUI functions for the 8900NET module.

Viewing Network Module Status

The Status page illustrated in Figure 16 displays 8900NET:

- Module identity, location and internal diagnostic Pass/Fail /Warning, status,
- Hardware and software properties, and
- Status of on-board hardware configuration switches (set as described in *Enabling Alarms and Fan Speed Control Option on page 18*).

A Status LED icon on each module page changes color to report status of network interface, frame bus, and internal diagnostics:

- Green indicates a Pass condition,
- Red indicates a Fail condition, and
- Yellow indicates a Warning condition.

Figure 16. 8900NET Module Network Status Page

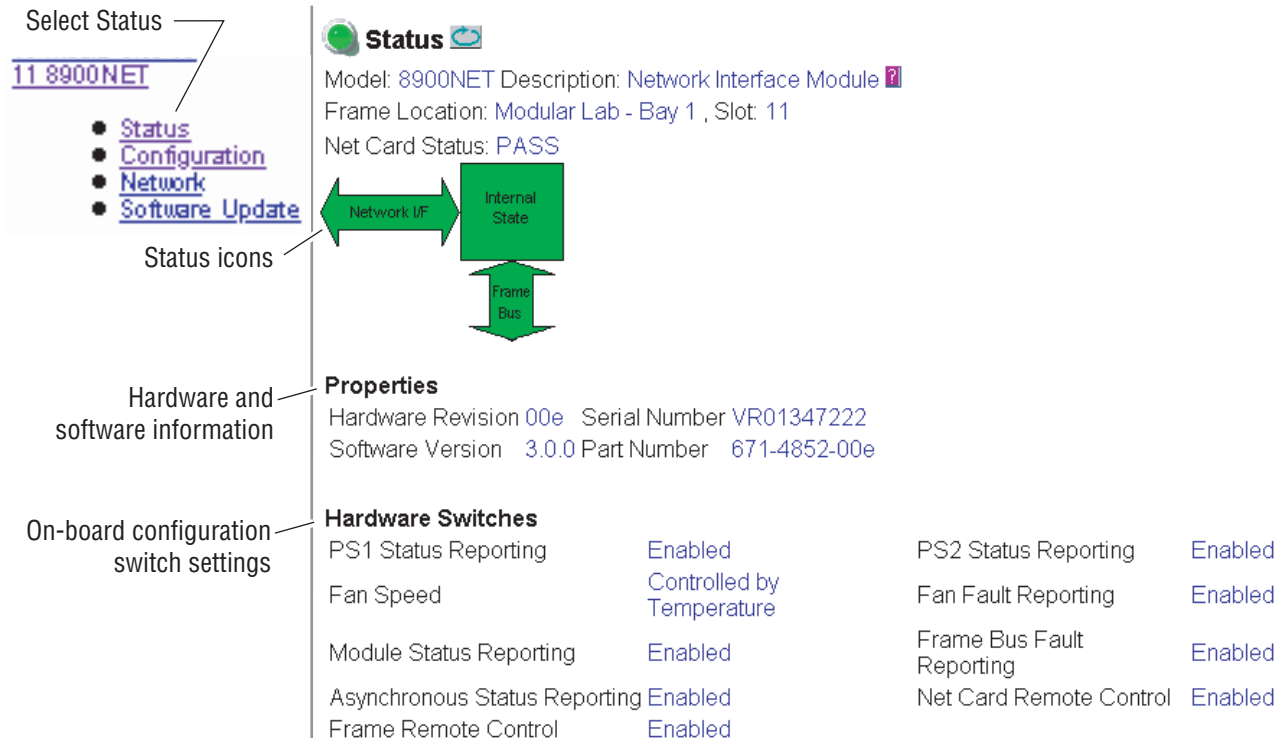

Network Module Configuration for SNMP

The Grass Valley Modular Control and Monitoring System uses the Simple Network Monitoring Protocol (SNMP) internet standard for reporting status information to remote monitoring stations. The 8900NET Configuration page provides SNMP setup. When SNMP Agent software is installed on the 8900NET module, enabled status reports are sent to an SNMP Manager such as the Grass Valley's NetCentral application.

Note There are both hardware and software report enable switches for each report. Both must be enabled for the report to be sent. Software report switches are set on the 8900NET Configuration page for the Frame, the 8900NET module, and each module slot.

SNMP Agent Installation

To use SNMP, the SNMP Agent software must be installed on the module. The Configuration page shown in [Figure 17](#) is displayed if the agent software has not already been installed. Click on the install button to view the license agreement.

Figure 17. Configuring the 8900 Network Module for SNMP

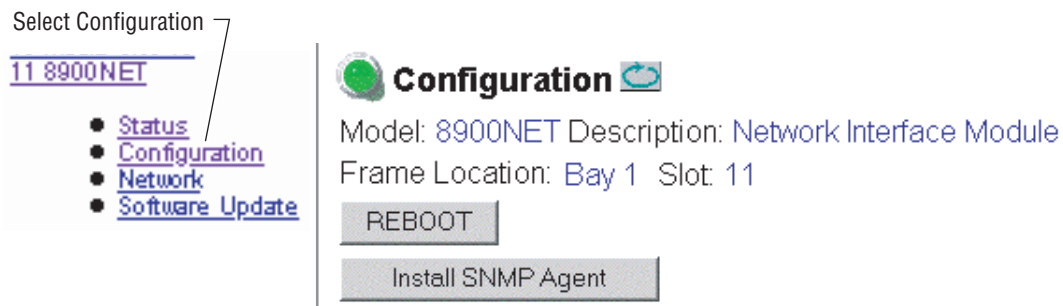

After reading the agreement, click on **Agree** to finish installing the SNMP Agent (Figure 18). Clicking the **Decline** button will abort the SNMP Agent installation and return you to the Configuration page.

Figure 18. Installing the SNMP Agent

This Agreement and the licenses granted herein will be governed by and construed in accordance with the laws of the United States and the State of Delaware, without reference to its conflict of laws provisions. Customer agrees that all disputes and litigation regarding this Agreement and the licenses granted herein will be subject to the exclusive jurisdiction of the courts of the State of California or of the Federal courts sitting therein.

All questions regarding the Agreement or the licenses granted herein should be directed to Contract Administration, Grass Valley Group, Inc., P.O. Box 59900, Nevada City, California 95959-7900.

070952001

When the SNMP Agent is successfully installed, the Configuration page will contain the setup items shown in Figure 19.

Figure 19. Configuring the 8900 Network Module with SNMP Agent Installed

Select Configuration

- 11 8900NET
- Status
- Configuration**
- Network
- Software Update

Configuration

Model: 8900NET Description: Network Interface Module
 Frame Location: QA Bay 9 , Slot: 11

REBOOT

Net Card SNMP Trap Reports

	Net Card Status	Hardware Switch
Enabled	<input checked="" type="checkbox"/>	<input checked="" type="checkbox"/>
Trap Severity	Alarm	Informational

SNMP Trap Destinations

IP Address	Community Name	Status	Operation
192.168.41.50	public	Active	Create-Go Create-Wait Active Not In Service Delete
192.168.42.189	public	Active	
10.190.26.146	public	Active	
10.190.26.146	public	Active	
10.16.6.4	public	Active	

Apply

Enable/disable SNMP status reporting

Enable/disable SNMP level of report severity

Enter a destination IP address and Community Name for up to five monitoring SNMP stations

Activation control

Activation status

SNMP Report Activation

Each report destination has an activation control that can select one of the following modes of operation:

- **CREATE – GO** creates a new report destination that becomes active after the next module reboot.
- **CREATE – WAIT** creates a new report destination that remains out of service until the user selects active and then reboots the module.
- **ACTIVE** changes a **NOT IN SERVICE** report destination to active after the next module reboot.
- **NOT IN SERVICE** changes an active report destination to inactive after the next module reboot.
- **DELETE** removes the report destination entry. If the entry was active it remains active until the next module reboot.

Note Report destination status does not change until the 8900NET module is rebooted.

The status column to the left of the activation operation pull-down window provides one of the following status reports:

- **<BLANK>** – No entry has been applied.
- **ACTIVE** – All new status reports will be sent to this destination.
- **NOT IN SERVICE** – The destination has a valid definition but the user has not activated it.
- **ACTIVE PENDING REBOOT** – This entry indicates the report destination will become active upon the next module reboot.
- **NOT IN SERVICE PENDING REBOOT** – This entry indicates the report destination will become inactive upon the next module reboot.
- **NOT READY** – The destination entry is invalid. The IP Address may not be properly defined or there is no IP Address or Community entry.

Media Module Slot Configuration

Media module slots may be named to reflect specific functions for that slot or module within the facility. The assigned name is stored on the 8900NET module and travels with that module if it is moved to another frame. To assign a slot name you must access the specific slot's page and open the Slot Config menu for that slot. An example for the 8960DMX is shown in Figure 20.

Figure 20. Media Module Slot Configuration Page

Select Slot Config

- 1 8920DMX
- Status
- Audio Group Management
- Recall/Save /user Settings
- Slot Config
- Software Update

Enable/disable module locator function

Name the module slot

Identify the input signal

Check box to restore saved config when new module installed

Learn module configuration to this slot

Read-only status of 2000NET module hardware settings necessary for enabling SNMP Trap Reports

Enable/disable specific SNMP reports for the slot

Read-only severity level assigned to each event

Slot Config

Model: 8920DMX Description: SDI/AES Demultiplexer ?

Frame Location: Modular Lab - Bay 1 , Slot: 1

Locate Module

Flash Off

Slot Identification

Name:

Input Signal Name:

Restore upon Install

Hardware Switch Controls

Module Status Reporting Enabled Asynchronous Status Reporting Enabled

Slot SNMP Trap Reports

	Slot Fault	Module Removed	Signal Loss	Reference Loss
Enabled	<input checked="" type="checkbox"/>	<input checked="" type="checkbox"/>	<input checked="" type="checkbox"/>	<input checked="" type="checkbox"/>
Trap Severity	Alarm	Warning	Warning	Warning

Locate Module

When enabled, the **Locate Module** function flashes the yellow COMM and CONF LEDs on the front of the module to locate in the frame.

Slot Identification

You may identify the module by typing a specific name in the **Name** field. The assigned name is stored on the 8900NET module and travels with the 8900NET module if it is moved to another frame. Select **Default** to enter the factory default module name.

Assign a name to the input signal to the module in the **Input Signal Name** field.

The slot configuration for each media module is automatically saved periodically (once an hour) to the 8900NET module in that frame. You may also select the **Learn Module Config** button at any time to save the current configuration for this slot. The configuration is saved on the 8900NET module. If the 8900NET module is removed or powered down, the stored configurations are not saved.

When the **Restore upon Install** box has been checked, the current configuration saved to this slot is saved as slot memory. When the current module is removed and another module of the same type is installed, the configuration saved to the 8900NET module will be downloaded to the new module. The box must be checked before the current module with the saved configuration is removed.

Hardware Switch Controls

This section is a read-only status report of 8900NET module switch settings for Module Status Reporting and Asynchronous Status Reporting. These functions must be enabled for the following Slot SNMP Trap Reports to function.

Slot SNMP Trap Reports

This section is displayed only when the SNMP Agent software has been installed on the 8900NET module. Slot SNMP traps can be enabled only when the hardware switches for Module Fault reporting and Asynchronous Status reporting are in enabled on the 8900NET module (dipswitch S1 segment 7 and dipswitch S2 segment 1).

The enabled SNMP traps will be reported to any SNMP manager that is identified as an SNMP Report Destination in 8900NET configuration. Trap severity is read-only hard-coded information that is interpreted and responded to by the SNMP Manager software configuration.

Module ID and Network Parameters

To view or change the module identity and currently assigned network addresses for the 8900NET module access the Network page illustrated in [Figure 21](#).

Note Depending on the type of frame this module is installed in, this network configuration is saved on either the 8900NET module or on the frame backplane. Refer to [Network Configuration Storage on page 22](#) for details.

Figure 21. 8900NET Module Network Identification Page

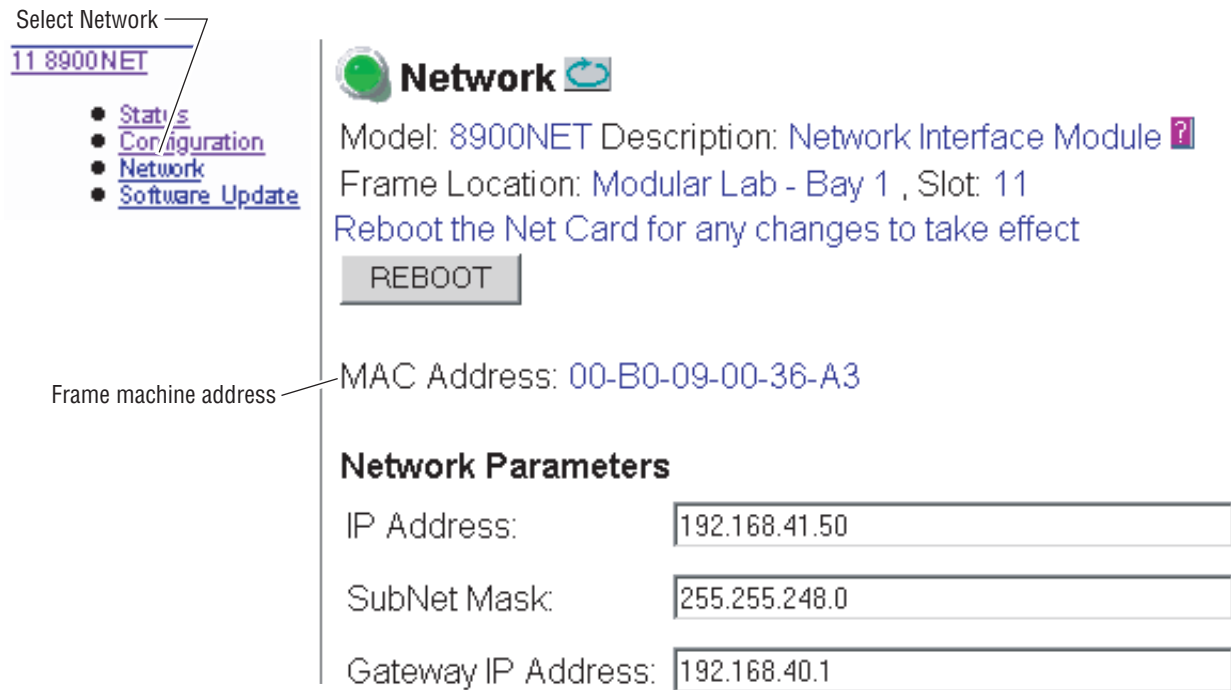

Frame machine address

After initial frame network addressing is done using the RS-232 port, subsequent address changes may be made using the menu shown above.

Note SubNet Mask and Gateway IP Address are required.

Rebooting the NET Module

You can reboot the 8900NET module from the Network page by clicking the **Reboot** button. A **Reboot** button can also be found on the Configuration page.

Updating Software

The following procedure describes the software download process for the 8900NET module running version 3.2.0 and later. Software download procedures for media modules residing in the networked Gecko 8900 frame will vary according to release date and hardware version. Modules can use the following procedure or may require a special cable assembly as detailed in the Compatibility Matrix in the Appendix on [page 65](#).

Note Updating the 8900NET from version 2.1 and earlier to version 3.2.0 or later must be done with an application available from Grass Valley. Software updating after version 3.2.0 can also be done using the NetConfig application if installed. Refer to the NetConfig manual for instructions.

Overview

The Modular Remote Monitoring and Control System is an extension of the Grass Valley Signal Management System (SMS) routing system and uses the same File Transfer Protocol (FTP) technique to download software.

Note This procedure assumes your Local FTP Server computer is a 32-bit Windows host running Win95, 98, NT or later.

If you do not have an FTP server, Grass Valley provides a free FTP server package that is easy to install and operate. This procedure assumes you will use the Xitami FTPD provided. If you already have an FTPD available, you can skip steps 3 through 5.

The software update process consists of the following steps:

1. Acquire the software update files and, if needed, the FTP Server package.
2. Place the module software update files into an FTPD modular directory.
3. Extract the FTP Daemon (Xitami FTPD).
4. Run the Xitami installation program.
5. Modify the FTPD configuration files to the Xitami directory.
6. Start the FTPD.
7. Use the 8900 GUI to initiate software updates.

Note When updating numerous Gecko 8900 modules, it is a good idea to dedicate one frame for the update process to avoid interrupting communication with active modules.

8. Verify the software update results.

Software Update Procedure

1. Acquire the software update files from Grass Valley (refer to [Figure 22](#)).
Software upgrade packages may be available on the Grass Valley web site. The free FTP server software is also available.
 - a. Connect to the Grass Valley modular software upgrade site using the following URL:

`http://www.thomsongrassvalley.com/downloads/`
 Select **Modular Products** from the table. Files are located under **8900 Series Modules**. Here you will also find the free FTP server software.
 - b. Create a temporary download directory on your PC:

`c:\temp\`

Figure 22. Acquiring 8900 Software from Grass Valley FTP Site

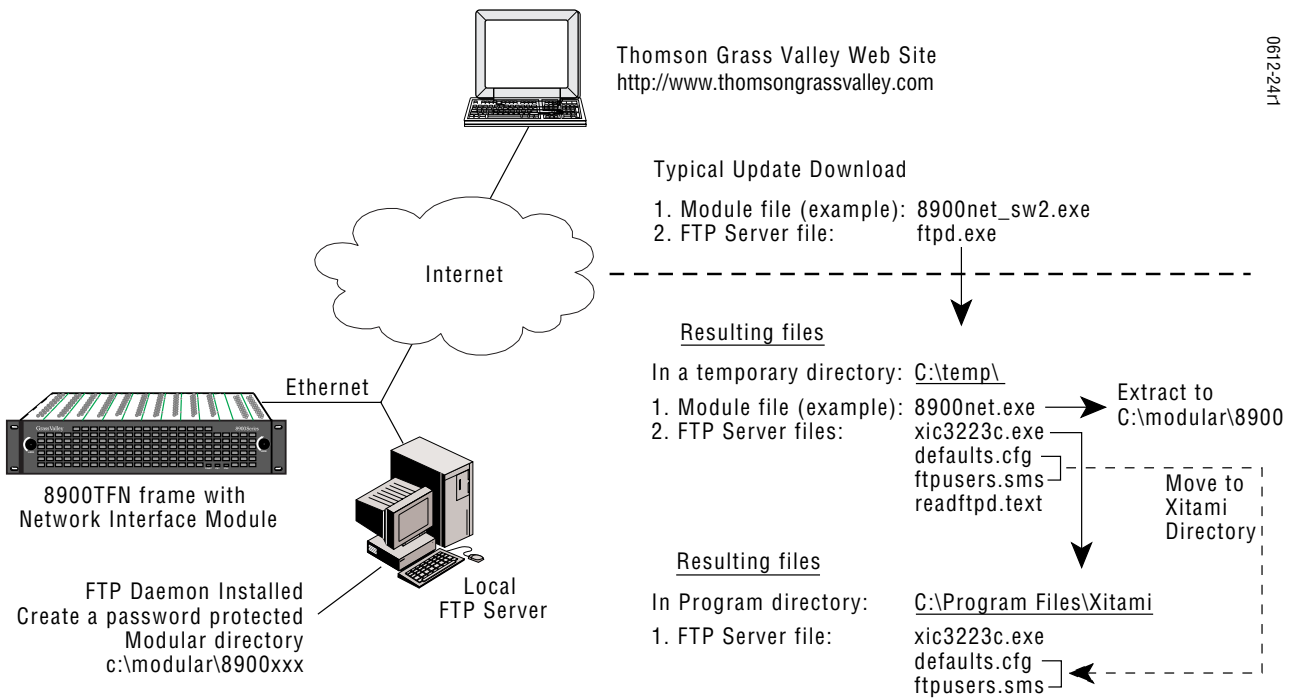

- c. Using the web browser, select the desired files. Click to download the file. You are queried to either **OPEN** the file or **SAVE AS**. Select the **SAVE AS** option and set the path to the temporary directory on your computer.

This process will trigger the download of the file to your computer.

Note If you have access to an existing FTP Server's directory, the module update files can be downloaded directly into that directory.

2. Move or extract the module update files into an FTPD modular directory.

The module software update files must reside in a directory that the FTPD can access. The Grass Valley supplied FTPD is configured to access a directory designated:

```
\modular\8900
```

The new software for the 8900 module will be either a binary file (.bin extension) or a field update file (.fld extension). Binary files (.bin) are for the 8900NET module updates and field update files(.fld) are for the 8900 Series modules.

- a. Open Windows Explorer on the local server computer.
- b. If one does not already exist, create a directory on the C drive:
c:\modular\8900
- c. Double-click the module software.exe file (in the temporary directory) and save it to the appropriate directory. The resulting file will be a .bin or .fld:

```
c:\modular\8900\8900net_sw300a_fw1.fld
```

Note The file name shown indicates: 8900NET, software version 3.00, firmware version 1.0.

3. Extract the FTPD (Xitami FTP Server) files.

Note This section is for facilities that do not already have an FTP Daemon (FTPD), also known as a File Transfer Protocol (FTP) Server, installed on the Gecko 8900 frame's network. For those facilities that already have an FTPD or other FTP Service available in their network, go to step 6.

Grass Valley provides a free FTP server for those facilities that do not have a local FTP service. The FTP server package is the same Xitami Web Server-FTP package that is provided with the Grass Valley SMS router upgrade package. The version of the Xitami Web-FTP server distributed with module software upgrades is for a 32-bit Windows host.

The FTP Daemon in the temporary directory is a self-extracting file (ftpd.exe). To extract the files:

- a. Open Windows Explorer and find the ftpd.exe file.

- b. Double click on the .exe file and extract the files to the temporary directory.

These files will be extracted:

- xic3223c.exe – the Xitami installation file,
- defaults.cfg – an FTPD configuration file that has been modified specifically for Grass Valley software downloads, and
- ftpusers.sms – the FTPD's admin file specifying user names and passwords network access to files in the ftp server directories.

- 4. Run the Xitami installation program.
 - a. Double Click on xic3223c.exe. You will see the Xitami Welcome (Figure 23).
 - b. Click on **Next >**.

Figure 23. Xitami Web Server Welcome

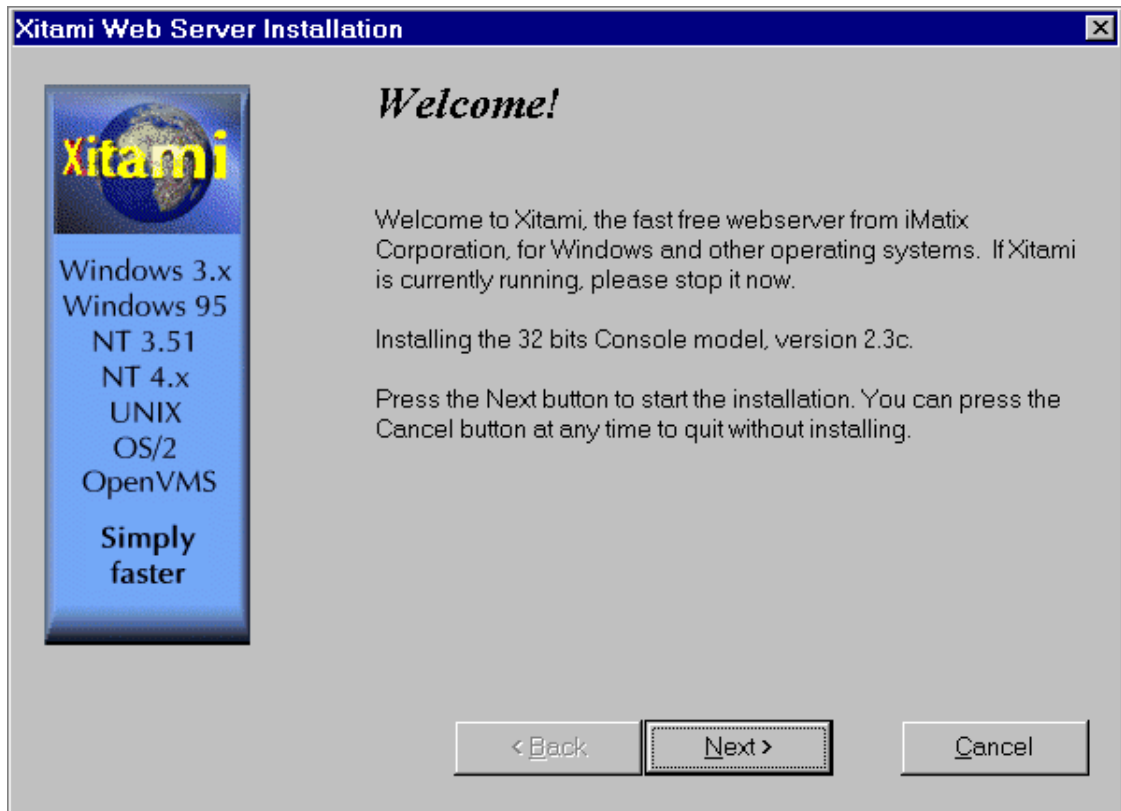

- c. You will see Xitami Installation Notes.
- d. Click on **Next >**.

- e. You will see Select Destination Directory (Figure 24). Do not change the default settings.
- f. Click on **Next >**

Figure 24. Select Destination Directory

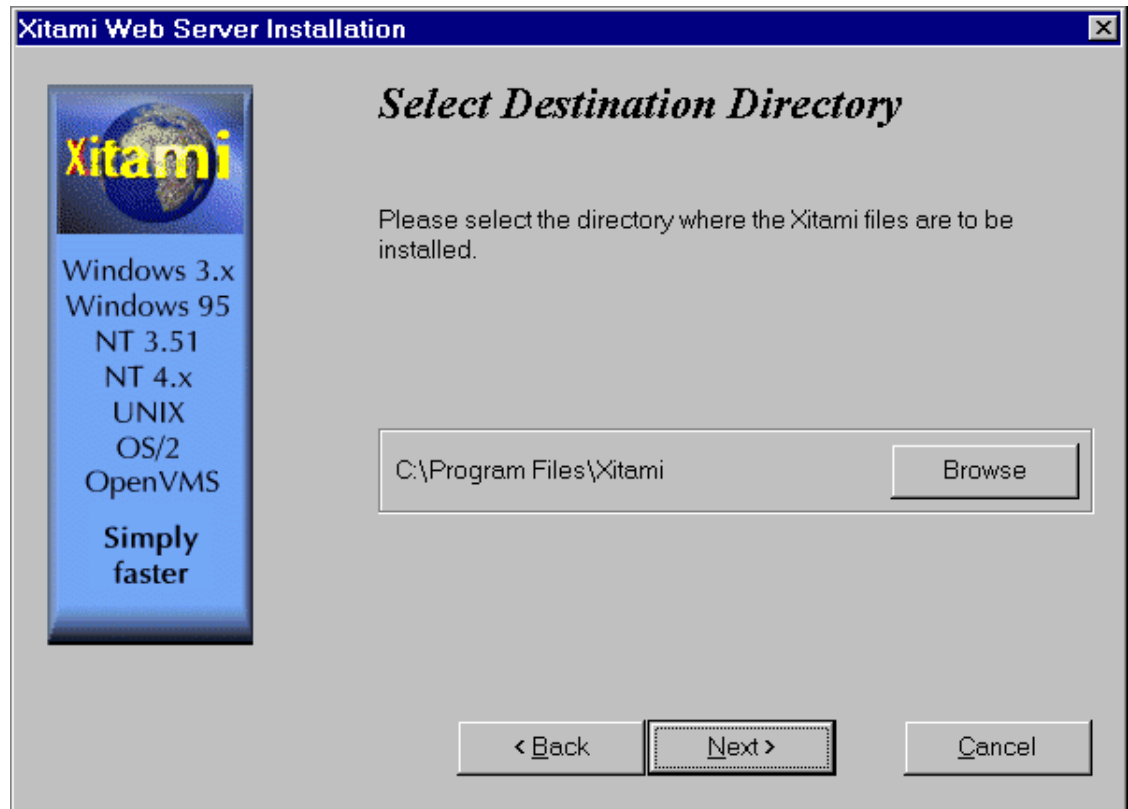

- g. You will see the Select Program Group screen (Figure 25). Do not change the default settings.
- h. Click on **Next >**.

Figure 25. Select Program Group

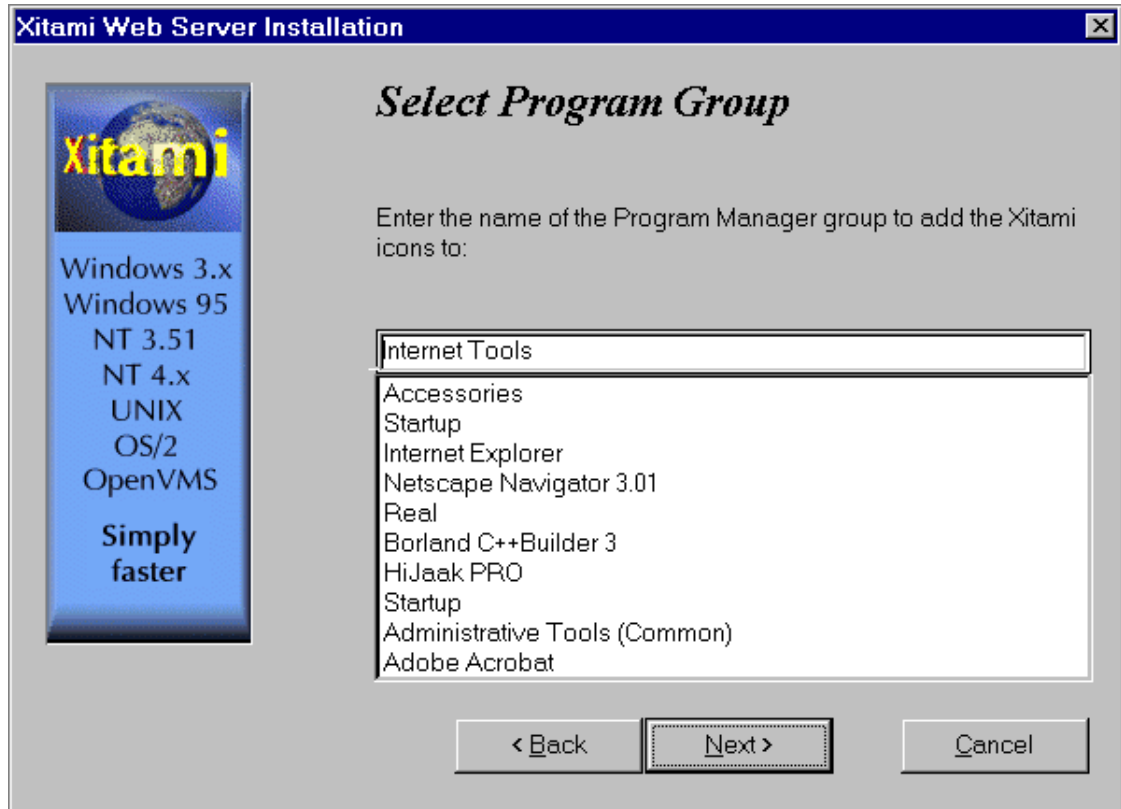

- i. You will see the Automatic Startup Query screen (Figure 26). Select **No**.
- j. Click on **Next >**.

Figure 26. Automatic Startup Query

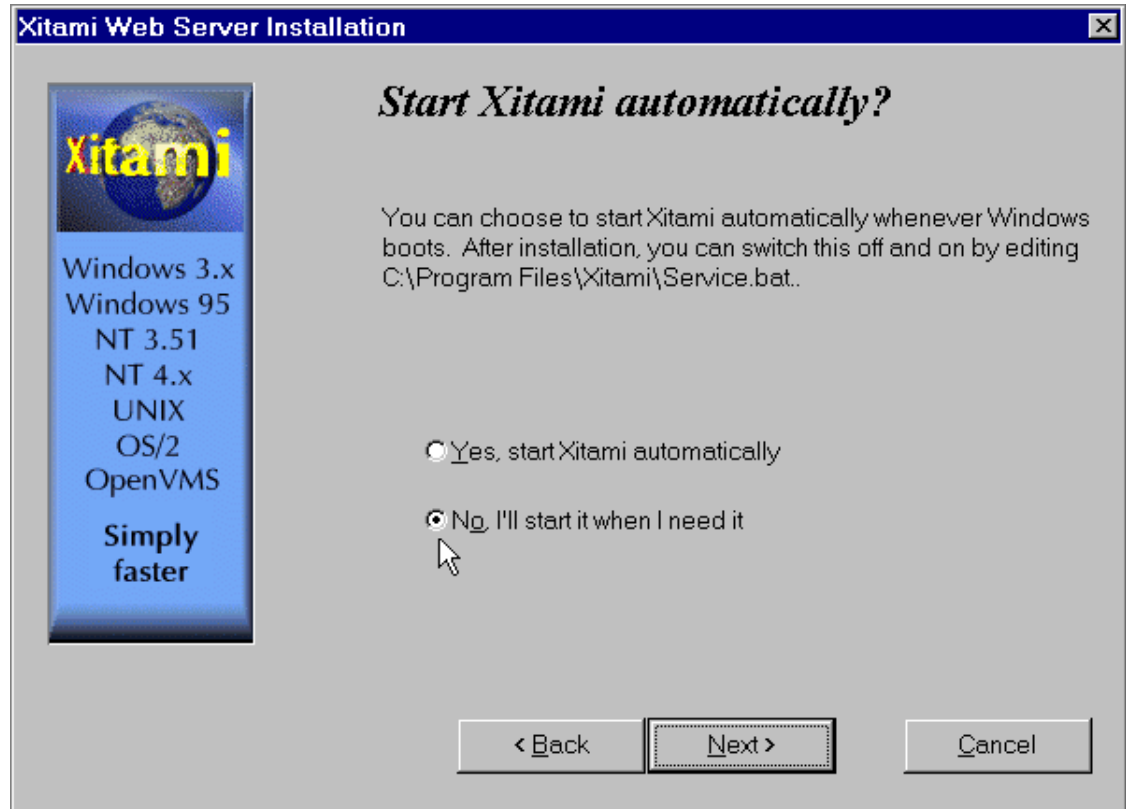

- k. You will see the Administration Password screen (Figure 27). Do not enter anything in these fields.
- l. Click on **Next >**.

Figure 27. FTPD Server Administration Password



- m. You will see the Choose Server Profile screen (Figure 28). Select **Tiny - never block another task**.
- n. Click on **Next >**.

Figure 28. Choose Server Profile

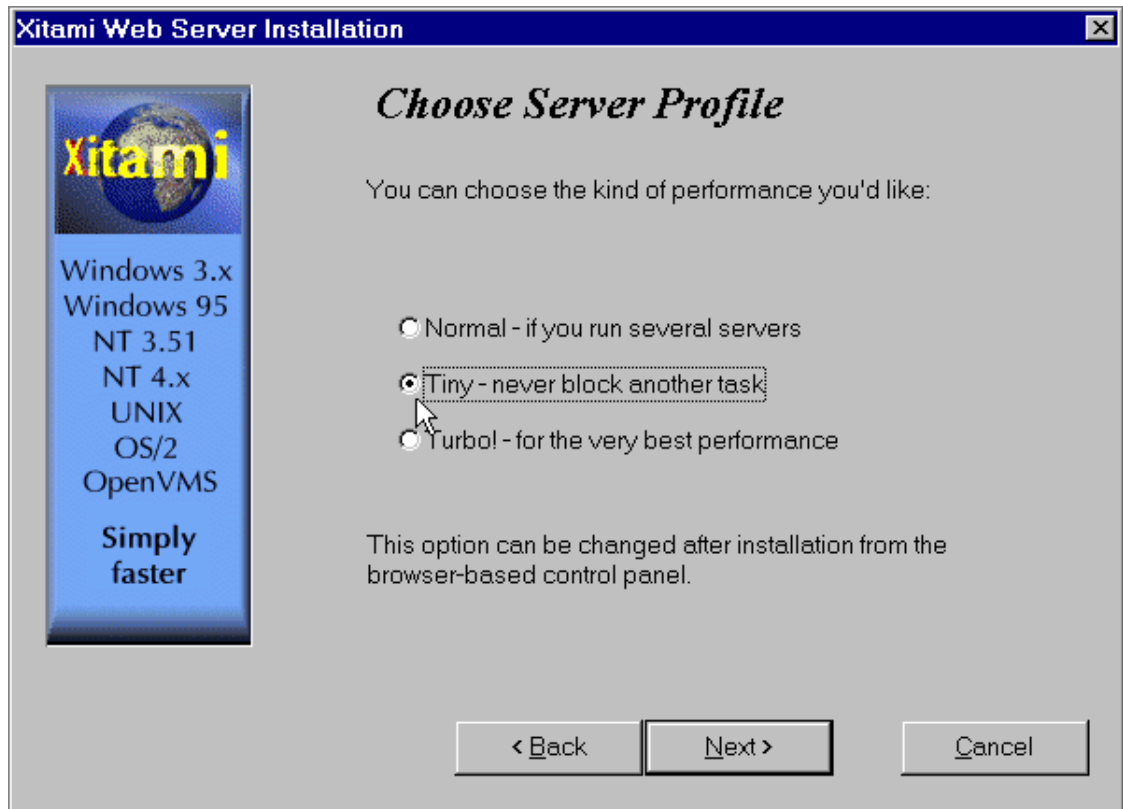

- o. You will see the Ready To Install screen. Click on **Next >**.
An installation meter box will appear, and upon completion, you will see the Installation Complete! screen.
- p. Click on **Finish**.

An Icon (see Figure 29) will have been created in the Program Group window that was selected in Step g (see Figure 24 on page 41).

Figure 29. FTPD Icon in Program Group Window

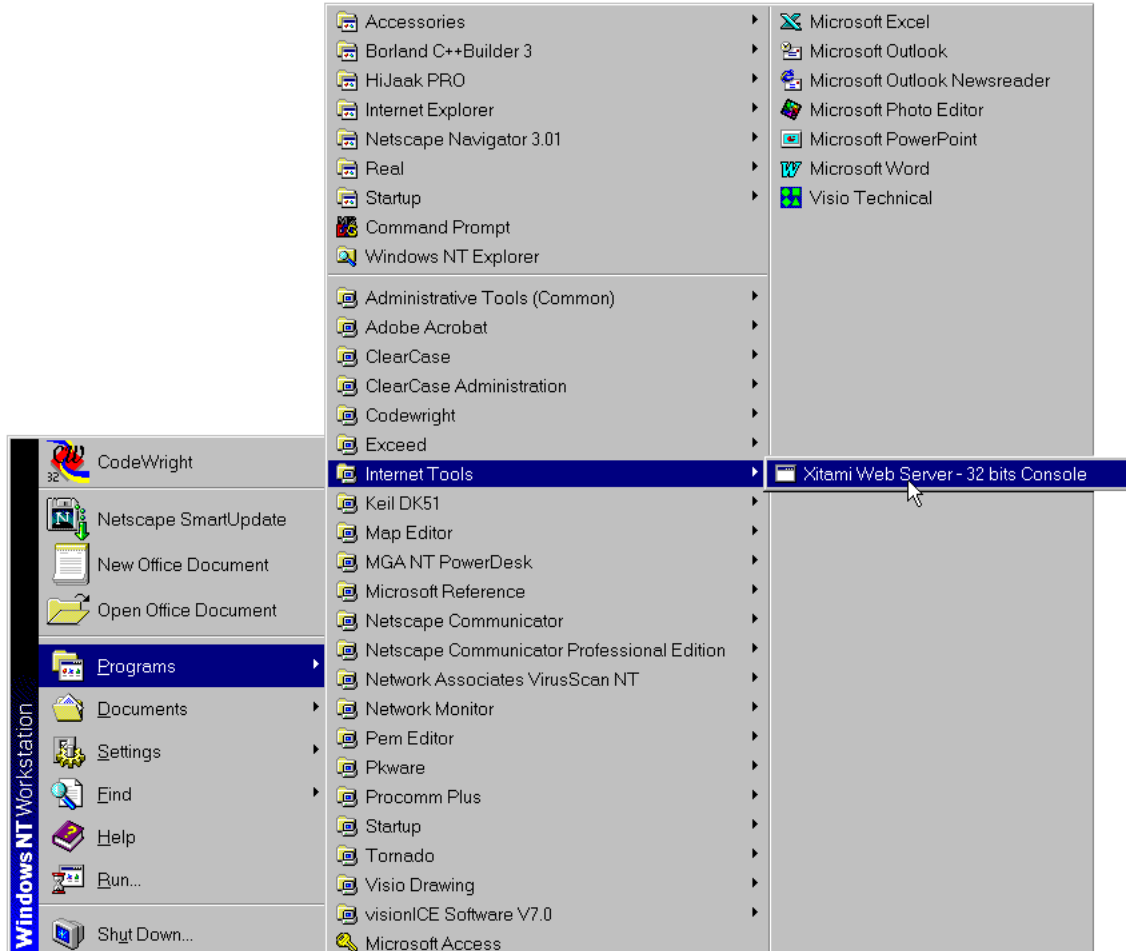

5. Move the FTP Daemon Start-up Configuration Files.

The FTP Daemon has now been installed and requires configuration files be placed in the Xitami directory.

- a. Open Windows Explorer.
- b. From the Explorer window, return to the FTPD directory and move the extracted defaults.cfg and ftpusers.sms files to the directory at:
c:\Program Files\Xitami

The defaults.cfg and the ftpusers.sms files contain default configuration instructions that the FTPD application reads at start-up.

6. Edit the ftpusers.sms file adding the user name information illustrated at the bottom of [Figure 30](#).

Figure 30. User Name and Password File ftpuser.sms

```
#
# ftpusers.sms - FTP users file for XITAMI
#
# Each section [Xxxx] defines a user who can connect to the FTP service.
# The user name is not case sensitive. Possible options for a user are:
#
# access=(G|P|D|M|R)+      Access rights, get/put/delete/mkdir/rmdir
# password=(-|*|""|text)   * = anonymous; - = disabled; "" = none
# root=directory          With leading '/' is absolute path; "" is
#                          main ftproot directory.
#
# aliases=1               Has access to aliases? By default 1 if
#                          root="", else defaults to 0. Note: this
#                          command is not currently implemented.
#
# NOTE: do not modify this file except for testing. When you re-install
# Xitami, this file may be replaced. Instead, change the ftp:user-file
# option and copy this file.
#
#*END

[smsuser]
Access=G
Password=smsuser
Root=/sms7000                #Must be able to find file

[username]
Access=G
Password=password
Root=/modular/8900          #Must be able to find file
```

Modular product
user information

Note The FTPD configuration files themselves should be installed in a password protected directory.

7. Start the FTPD.

If the Xitami Web Server (FTPD) is not already running, start it.

- a. Click on the Start popup window on the PC.
- b. Select Programs, then Internet Tools, and click on Xitami Web Server – 32 bit console ([Figure 29 on page 46](#)).

The Xitami Console will open as a DOS window. There will be a log of events, at least one of which will indicate it is accepting connections (see [Figure 31](#)).

Figure 31. Typical FTPD Console Screen

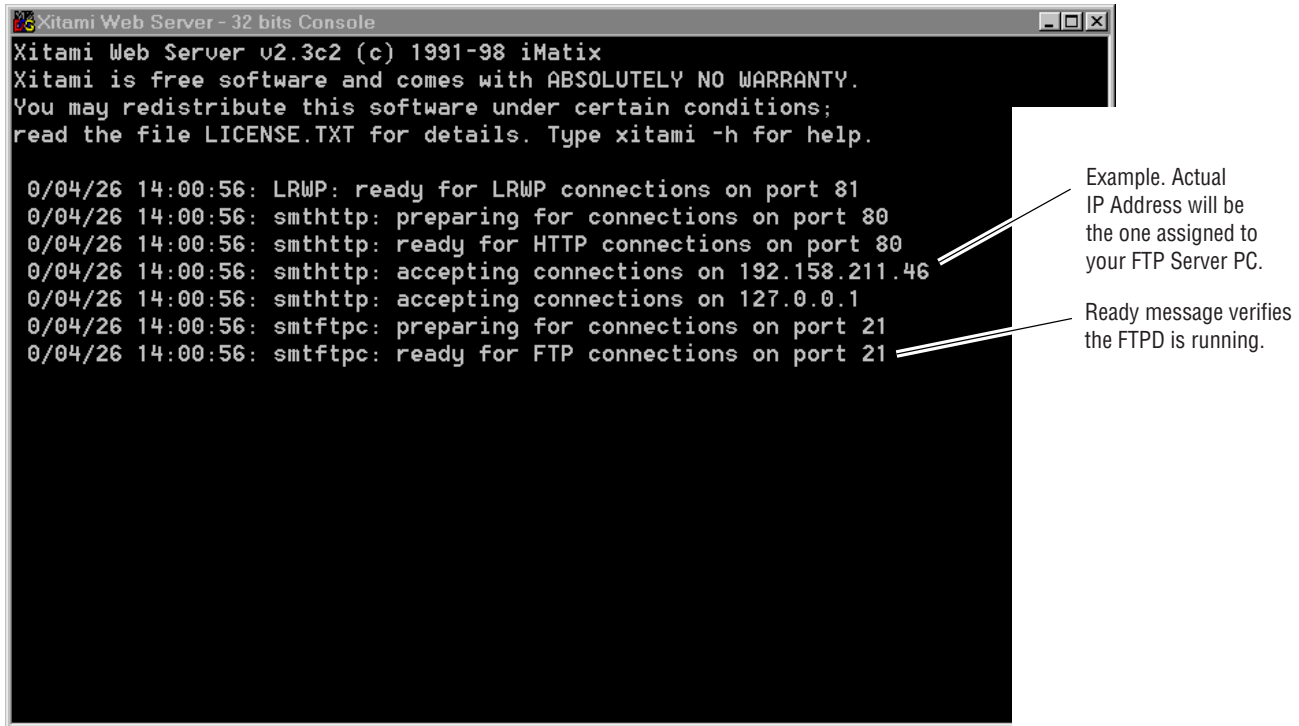

The IP Address line should actually indicate the IP Address of the PC you are using for the FTP server. This is the IP Address that will be used to initiate the software update.

The line that verifies that the FTPD is running reads:

```
ready for FTP connections on port 21
```

8. With the FTPD running, use the 8900 GUI to initiate software updates. Use the web-browser to:
 - Access the appropriate Software Update page for a given module,
 - Enter the required data into the HTML Form on that page, and
 - Submit the form.

The 8900 frame uses the data in the form to contact the FTPD on the server, download the update file, and reprogram the targeted module.

Note Prior to attempting update of software, refer to the target module's manual and confirm that the Remote/Local Only jumper is in the Remote position.

Note To monitor the progress of the download, use the serial port connection (see [Figure 32](#)) with a computer running a terminal emulation application

Figure 32. Serial Port Console and PC Network Connections

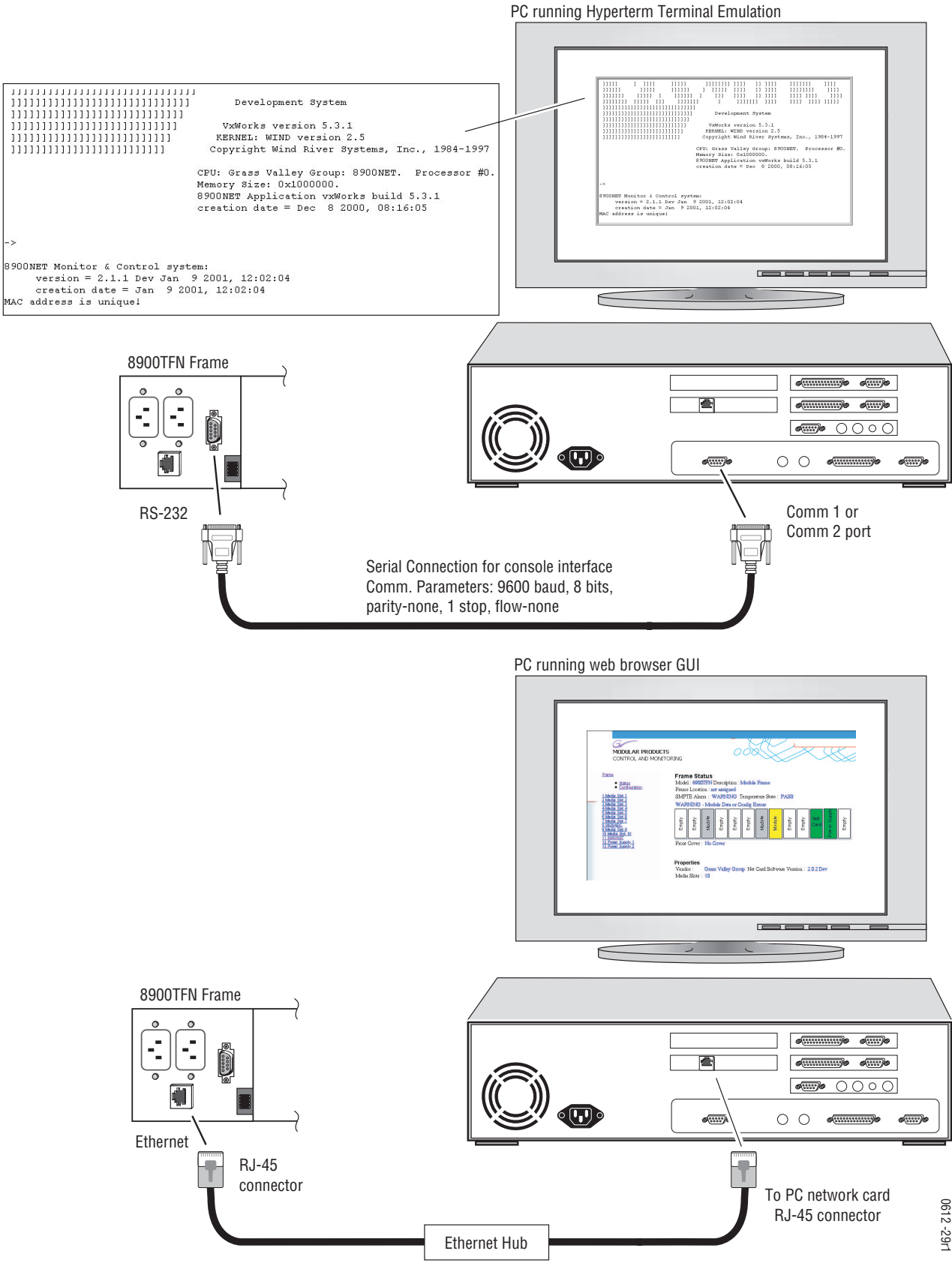

0612-2911

- a. Open a web browser on a PC that is connected over the network to the Gecko 8900 frame.
- b. Enter the URL of the frame where the module to be updated resides. The frame's main status page will appear.
- c. Click on the module's link and then click on Software Update (the 8900NET module link is shown in [Figure 33](#)).

The module's Software Update page will appear. This form is the same for all 8900 modules that support network software update.

Note Earlier 8900NET versions differ in the layout and number of entry fields. Non-essential fields have been removed in the later release.

If the module does not support network software update, the page will be blank except for the header and status information.

Figure 33. 8900NET Module Software Update Page

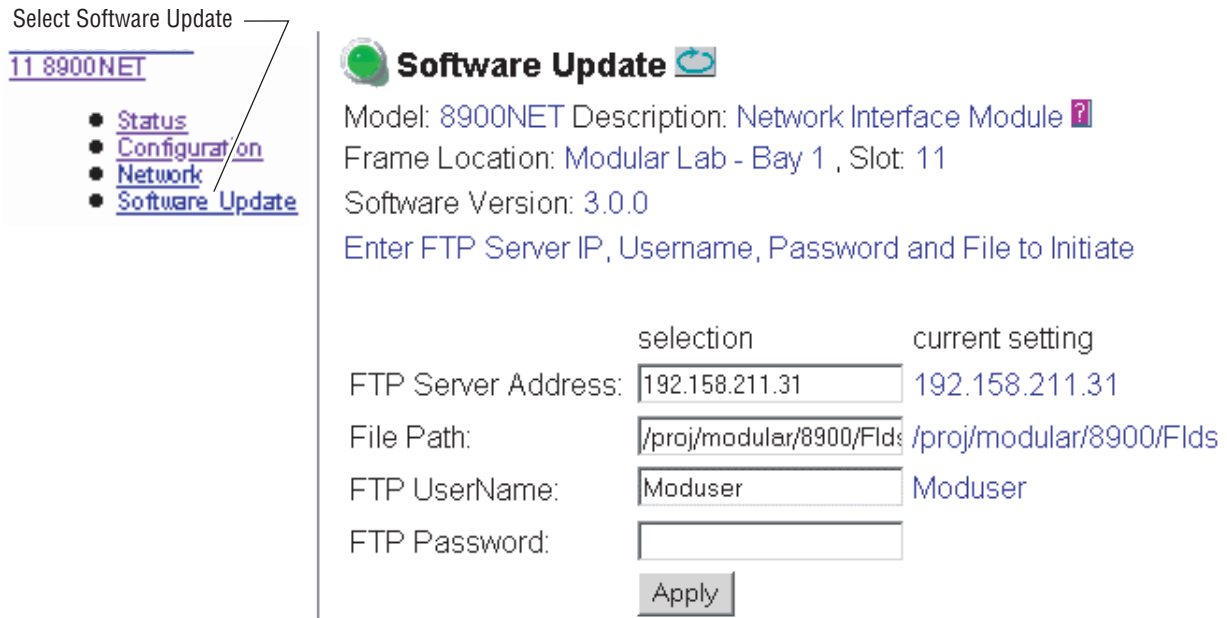

- d. In the FTP Server Address field, enter the IP Address of the PC that has the FTPD installed and running.
- e. You can enter the Host Name of the PC that has the FTPD running into the FTP Server Name field. This is an optional step and can be omitted.
- f. Click on **Apply** to set the FTP Address.
The web page will refresh and the new FTP address should be displayed as the Current Settings.
- g. In the File Path field, enter the file name of the software update file.

- h. Submit the form and start the update process by entering the user name and password and clicking on **Apply**.

After you click on **Apply**, the web page will display a Progress Monitor. Wait a few seconds for the Progress Monitor to begin.

- i. If the file entered in the file path is invalid or the file cannot be found, a **File Not Found** message will appear in the Progress Monitor Results line (Figure 34). Select the Software Download link or the **Refresh** button to refresh the page to return to the download page and re-enter the file name.

Figure 34. 8900NET Software Download Progress Monitor

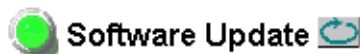

Model: [8900NET](#) Description: [Network Interface Module](#)
 Frame Location: [QA Bay 9](#) , Slot: [11](#)
 Software Version: [3.0.0](#)

```

Progress Monitor
Opening File "/proj/modular/8900/Flds/89Net/89Nettest.bin"
File Not Found
Results: File Not Found
  
```

- j. If the login password is incorrect, the Progress Monitor will report with a **Login Incorrect** message as shown in Figure 35. Select the Software Download link or refresh the page to return to the download page and re-enter the correct login.

Figure 35. Login Incorrect

```

Progress Monitor
Opening File "/proj/modular/8900/flds/89Net/test.bin"
Login Incorrect
Results: Login Incorrect
  
```

- k. Once the download has started and there are no error messages, wait for the Success screen to appear, then click on Software Update or the refresh button again to refresh the page.

Note Do not click anywhere on the web page while the download is in progress unless you receive a File Not Found or Login Incorrect Results message.

Once the download is successful, the Progress Monitor will report a Success message similar to [Figure 36](#).

Figure 36. 8900NET Software Update Failure Notice

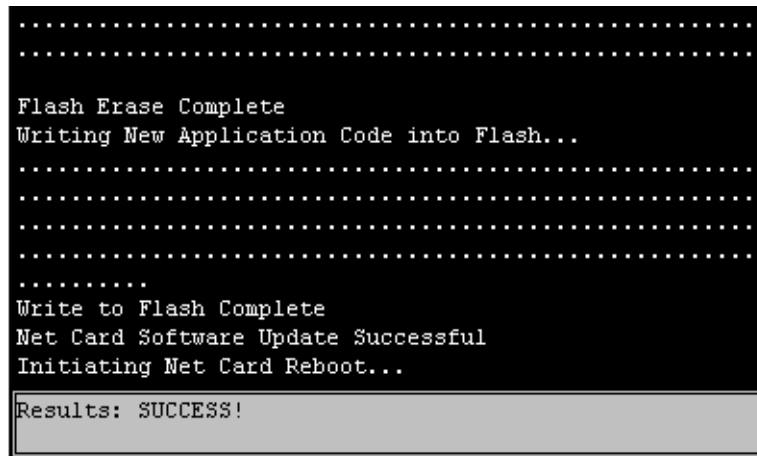

- 9. Verify the software update results by checking the Installed Software Version in Properties portion of the 8900NET Status web page.

The software and firmware (if applicable) numbers should match that indicated in the .bin or .fld file name (see [Step 2](#) of this procedure for file names and version numbers).

Update Processing Details

Upon receipt of a software update form from a module, the 8900NET module will contact the FTP Server, requesting the specified path. The 8900NET will send the user name and password to FTP server to gain access to the file.

Once the file has been successfully FTP'd from the FTP Server, the 8900NET will begin the module software compatibility check and upgrade process.

The module software compatibility check uses compatibility information included in the Field Update File to ensure that the new software was intended for this module. In the event that there is a mismatch, the 8900NET will abort the upgrade.

If compatibility is okay, the download is performed and the subject module is rebooted.

Specifications

Table 5. 8900NET Specifications

Parameter	Value
Recommended Software	
Web browser	Netscape 4.x or Internet Explorer 4.x or later
PC operating system	Windows 95/98 or later
Terminal emulation	Hyperterminal
Environmental	
Frame temperature range	0 to 45° C
Operating humidity range	0 to 90% non-condensing
Non-operating temperature	0 to 45° C
Mechanical	
Frame type	8900 Series
RS-232 connector	DB-9 Female
Ethernet connector	RJ-45
Frame alarm connector	DB-9 Female or BNC (depending on frame model)
Power Requirements	
Supply voltage	+12 V, -12 V
Power consumption	< 6 W

Service

The 8900NET modules make extensive use of surface-mount technology and programmed parts to achieve compact size and adherence to demanding technical specifications. Circuit modules should not be serviced in the field.

If your module is not operating correctly, proceed as follows:

- Check frame and module power and signal present LEDs.
- Check network connections at the frame and network routing devices.
- Verify that all ethernet devices have a unique MAC and IP Address/ Domain Name.
- Reboot the 8900NET module (see *Rebooting the NET Module on page 36*).

Refer to [Figure 10 on page 16](#) for the location of PWR LED and [Table 1 on page 17](#) for proper LED indications.

If the module is still not operating correctly, replace it with a known good spare and return the faulty module to a designated Grass Valley repair depot. Call your Grass Valley representative for depot location.

Refer to [Contacting Grass Valley](#) at the front of this document for the Grass Valley Customer Service Information number.

Troubleshooting GUI Operation

The following is a list of possible 8900NET GUI and network problems and logical steps for troubleshooting them.

Cannot Open Any of the Frame's Web Pages

1. Check power to the frame.
 - a. Is at least one of the power supplies operating?
 - b. Is the 8900NET module's PWR LED on?
2. Check that the frame is physically connected to the network.
 - a. Is a cable plugged into the RJ45 connector of the frame?
 - b. Is that cable also connected to a 10Base-T Ethernet hub?
 - c. Does the 8900NET module's ETHER LED indicate network activity?
 - d. Does the Ethernet hub have any indication that a link is established to the frame?

3. Is the correct IP Address/URL being used to address the frame?

If a Domain Name is being used to address the frame, try to connect using the frame IP Address instead.

The Domain Name may not be properly assigned in the local Domain Name Server or in the workstation's host file.

The Domain Name Server may not be available to the workstation. Check that the 8900NET module has been properly configured.

- a.** Is the correct IP Address or URL being addressed in the web browser?
- b.** Was the 8900NET module configured over the serial connection with the **SETUP** command?
- c.** Has the 8900NET module been assigned the correct IP Address in **SETUP** (re-run setup over the serial connection)?
- d.** Is the workstation in the same subnet as the frame? If not:
Has the 8900NET module been assigned the correct Default Routing Address?
Has the 8900NET module been assigned the correct Subnet Mask?
- e.** Has the 8900NET module been rebooted since new IP Address, Default Routing, or Subnet Mask were assigned or changed?

4. Check if the frame web pages can be opened from a different workstation on the network.

5. Is the subject workstation physically connected to the network?

6. Check that the workstation and browser have been properly configured.

- a.** Can the frame be opened from a different workstation?
- b.** Has the workstation been assigned a proper IP Address?
- c.** Has the workstation been assigned a Gateway Address?
- d.** Is the browser configured to connect to the correct port?

Is it attempting to connect through a modem when it should be connecting through a network interface module?

Some laptop have two separate network ports, one for stand-alone operation, and the other for operation with a docking station. Is the correct port being used?

7. Check that network traffic can be routed between the workstation and the frame.
 - a. If the workstation supports a network ping, ping the frame. For example, using Windows NT:
 - Open a command prompt (DOS window)
 - In the DOS window, enter:
C:\> PING FRAME'S IP ADDRESS
 - The results will indicate if the ping reached the frame.
 - b. If the workstation does not support a network ping, ping the workstation for the frame serial interface:
 - In the frame serial command window, enter:
->PING "WORKSTATION'S IP ADDRESS"
 - The workstation's IP address must be inside the double quotes. The results will indicate if the ping reached the workstation.
 - c. If the network ping failed, there may be a network problem between the frame and the workstation. To ensure it is not the frame, check the frame with a point-to-point connection:
 - Using a crossover Ethernet cable, connect the frame directly to a workstation. The workstation should be assigned an IP Address on the same Subnet as the frame. Attempt to load the frame's web page from a Browser on this workstation.
8. If the point-to-point connection attempt fails call Customer Service. If the point-to-point connection attempt succeeds, the problem is somewhere in the network between the original workstation and the frame.
 - a. Check the connectivity to the frame from different locations in the network to attempt to isolate physical disconnect problems.
 - b. Check the connectivity to the frame from inside and outside the frame's subnet to isolate IP Gateway routing problems.

- c. Check for possible Ethernet MAC Address collisions.

If the Frame ID Memory chip installed on the rear of the frame is missing or has failed, the frame adopts the default Ethernet MAC Address.

If more than one frame in the Network adopts the default Ethernet MAC Address, there could be address resolution problems. Upon power up the frame will indicate in the serial port console window, either:

“MAC ADDRESS IS UNIQUE!” – THE FRAME HAS SUCCESSFULLY RETRIEVED A UNIQUE ETHERNET MAC ADDRESS FROM THE FRAME ID MEMORY CHIP

or

“MAC ADDRESS IS DEFAULT!” - THE FRAME IS USING THE DEFAULT ETHERNET MAC ADDRESS. THE FRAME ID MEMORY CHIP IS MISSING OR HAS FAILED. CALL GRASS VALLEY GROUP CUSTOMER SERVICE

Cannot modify parameters on Web Page

1. Check if parameters can be set for other modules.

If so, the module may be in a remote lockout state.

- a. Check if the LOC/REM – LOCAL jumper on the module is set for local control only. (Refer to that specific module’s manual for help.)
- b. In version 2.0 and later of the 8900NET module software, the web pages for a module in the remote lockout state will indicate that module remote control is disabled and the module’s controls on the web pages will be in read-only mode.

If other modules are not controllable, the entire frame may be in a remote lockout state. In this state, software updates to the modules and the 8900NET module are also locked out.

- c. Check The 8900NET module’s status page if the frame remote control is disabled.

If so, flip Switch 3 on the S2 DIP switch block (FRAME CNTRL) to the enabled setting.

2. If it is only a specific parameter that is read-only, the module may be in a mode assigning read-only operation to that parameter. Refer to the module’s instruction manual.
3. If only the 8900NET module is read-only, the 8900NET module may be in remote lockout mode.
 - a. Check the 8900NET module’s status page to see if the **NET CARD REMOTE CONTROL** status is disabled.
 - b. If so, flip Switch 8 on the S1 DIP switch block (NM CNTRL) to the enabled setting.

Cannot Connect to the Frame From a VTECS1 VideoFrame Control Panel

- 1.** Check that the frame is powered and configured with a 8900NET module on the network.
- 2.** Check that the 8900NET module in the frame is loaded with software version 2 or later.
Version 1 software does not support the control panel connection.
- 3.** Check that the control panel has been properly configured with IP Address, Gateway IP Address, and Subnet Mask. (Refer to the control panel's help feature or instruction manual.)
- 4.** Check that the frame's correct IP Address has been configured in the control panel's frame address.
- 5.** Check that the control panel is physically connected to the network.
 - a.** Check that the control panel is connected to a port on an Ethernet hub.
 - b.** Check if the L LED (L for link) on the back of the control panel is on.
If the LED indicates no link (off), try a different hub port connection.
If the LED still indicates no link, change the cable.
If the LED still indicates no link, contact VideoFrame.
- 6.** Check that the frame is addressable by the control panel.
 - a.** Check if the T LED (T for transmit) on the back of the control panel flashes upon the attempt to connect to the frame.
If T does not flash, contact VideoFrame.
 - b.** Check if the R LED (R for receive) on the back of the control panel flashes upon the attempt to connect to the frame.
If R does not flash, there may be a problem in the network path between the frame and the control panel.
- 7.** Check that the frame is addressable on the network from a Web browser, refer to the steps on [page 54](#).
 - a.** Attempt to connect to a different frame.
If successful the problem may be with the original frame or the path between the control panel and the original frame.
 - b.** Check from a workstation connected to the same Ethernet hub as the control panel. If unsuccessful, there may be a problem with the network path between the frame and this hub.

Event Messages From the Frame Are Not Being Displayed by NetCentral or Another SNMP Manager Application

1. Check that the frame is powered on and configured with an 8900NET module on the Network.
2. Check that the 8900NET module in the frame is loaded with software version 2.1 or later.

Earlier versions of software do not support SNMP.

3. Check that the SNMP Agent has been installed and configured on the 8900NET module.

View the 8900NET module **CONFIGURATION** page and note the event configuration parameters, the **NET CARD EVENT REPORTS** form and **REPORT DESTINATIONS** table.

If these are not visible, install the SNMP Agent per the instructions in the manual.

4. Check that the IP Address and Community Name for the SNMP Manager has been assigned in the **REPORT DESTINATIONS** table and is Active.
 - If there is no entry for the SNMP Manager in the Table, the SNMP manager's IP Address and Community name must be entered (see *Network Module Configuration for SNMP* on page 30).
 - If the entry for the SNMP Manager is incorrect, it must be corrected, activated, and the 8900NET module must be rebooted.
 - If the entry has been entered and the Status of the entry is reported **NOT IN SERVICE**, the Active operation for that entry must be selected, applied and the 8900NET module must be rebooted.
 - If the entry has been entered and the Status of the entry is **NOT READY**, the entry must be corrected, activated and the 8900NET module must be rebooted.
 - If the entry has been entered and the Status of the entry is **ACTIVE – PENDING REBOOT**, the 8900NET module must be rebooted.

5. Check that the particular event has been enabled in the frame.
 - For all events, check that the STATUS switch (Switch 1) on the S2 DIP switch block of the 8900NET module is Enabled.
 - For Module Failure-Fixed events:

Check that the MODULE switch (Switch 5) on the S1 DIP switch block of the 8900NET module is Enabled, and

Check that the **SLOT STATUS REPORTING** parameter on the slot's **SLOT CONFIG** page is Enabled.
 - For Power Supply Failure-Fixed events:

Check that the PS1 or PS2 switch (Switch 1 or 2) on the S1 DIP switch block of the 8900NET module is Enabled, and

Check that the **POWER SUPPLY STATUS REPORTING** parameter on the power supply's **CONFIGURATION** page is Enabled.
 - For 8900NET module Failure-Fixed events, check that the **NET CARD STATUS REPORTING** parameter on the 8900NET module's **CONFIGURATION** page is Enabled.
 - For Hardware Switch change events, check that the **HARDWARE SWITCH REPORTING** parameter on the 8900NET module's **CONFIGURATION** page is Enabled.
 - For Frame Bus Failure-Fixed events:

Check that the FRAME BUS switch (Switch 6) on the S1 DIP switch block of the 8900NET module is Enabled, and

Check that the **FRAME BUS STATUS REPORTING** parameter on the frame's **CONFIGURATION** page is Enabled.
 - For Front Cover Removed -Installed events, check that the **COVER STATUS REPORTING** parameter on the frame's **CONFIGURATION** page is Enabled.
 - For Frame Bus Failure-Fixed events:

Check that the FRAME BUS switch (Switch 6) on the S1 DIP switch block of the 8900NET module is Enabled, and

Check that the **FRAME BUS STATUS REPORTING** parameter on the frame's **CONFIGURATION** page is Enabled.
 - For Cooling Fan Failure-Fixed events:

Check that the FAN switch (Switch 4) on the S1 DIP switch block of the 8900NET module is Enabled, and

Check that the **FAN STATUS REPORTING** parameter on the frame's **CONFIGURATION** page is Enabled.
 - For Module Health Failure-Fixed events,

Check that the MODULE switch (Switch 5) on the S1 DIP switch

block of the 8900NET module is Enabled, and

Check that the **MODULE HEALTH REPORTING** parameter on the frame's **CONFIGURATION** page is Enabled.

- Check that the SNMP Manager is properly configured to receive the Event Messages.

Check that the SNMP Manager has been assigned the same community name as in the frame's configuration.

6. Check the network connectivity between the SNMP Manager and the frame as described in the steps on [page 54](#).

Functional Description

Refer to the block diagram in [Figure 37](#) while reading the following functional description.

Figure 37. 8900NET Block Diagram

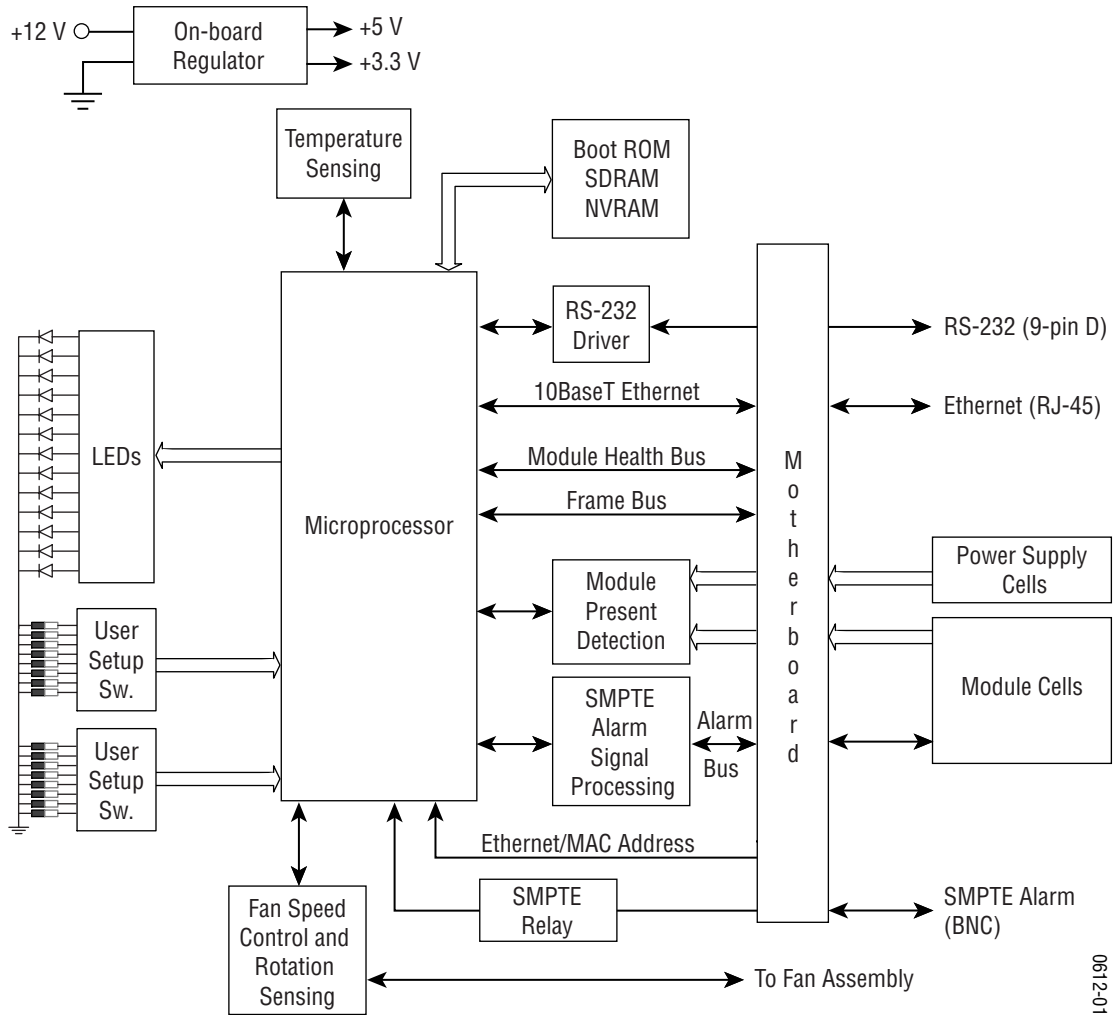

Temperature Sensing

Two temperature sensors on the module report to the microprocessor when they detect:

- External ambient temperature above 50° C, or
- Internal frame temperature above 70° C.

The microprocessor will then report a temperature fault.

ROM and RAM

Software updates can be made to the 8900NET ROM through the Web-based interface. Non-volatile RAM is provided to store key setup values when power is cycled.

Ethernet Port

The 10Base-T Ethernet port provides configuration and monitoring access to the frame, frame modules and the 8900NET module using a Web browser.

RS-232 Serial Port

The RS-232 port is used to initialize the module with critical network parameters including a static assigned IP Address. Ethernet MAC address is stored on a serial EPROM on the frame. (The frame needs both MAC and IP Addresses.)

Module Health Bus

The Module Health bus connects all the audio/video module cells to the microprocessor. It is used to report module faults or data errors.

Frame Bus

The Frame Bus provides serial communication to each of the audio/video modules for remote configuration and monitoring over a network.

Module Present Detection

Module Present lines from cells 1 through 10 and Present/Health lines from cells 12 and 13 are monitored by the microprocessor using the Module Present Detection circuitry. For cells 1 through 10, this circuit reports to the processor whether a module is present and if it supports frame bus communications (control and monitoring). For cells 12 and 13, this circuit reports if the power supply is present and if it is working properly.

Fan Speed Control and Monitor

The fan speed circuit controls the speed of the fans based upon the ambient temperature in the area in which the frame is located. If the temperature is 30° C or lower, the fans are set to minimum speed. For temperatures above 30° C, the fan speed is set higher as the temperature increases. The fan speed is set to maximum for ambient temperatures above 40° C. The control circuit can be overridden so the fans are set to maximum speed, using a jumper on the board.

On-board Regulator

+12 V supply voltage is regulated on-board to provide +5 V and +3.3 V to the module.

Appendix

Compatibility Matrix

The compatibility matrix in [Table 6](#) lists the modules that can reside in the 8900TFN frame, features that are supported, the module assembly numbers and how software updates are handled. For the latest information on any module, software available and the Release Notes and latest Instruction Manual, visit the Support link on the Grass Valley web site (refer to [Contacting Grass Valley](#) at the beginning of this manual).

Table 6. 8900 Compatibility Matrix

Model #	Assembly #	Control & Monitoring Support ¹	Control & Monitoring Notes ²	Software Update
8931	160169-00	no comm	–	n/a
8936	160170-00	no comm	–	n/a
8941	160171-00	no comm	–	8900_FLOAD-CBL ³
8916	671-4853-00	basic status	Id defect, faults not reported	Not upgradeable
	671-4853-01	full c&m	–	8900_FLOAD-CBL ³
	671-4853-02			
8920DAC	671-4795-00	full c&m	Id defect, faults not reported	8900_FLOAD-CBL ³
	671-4795-01		Faults not reported	
	671-4795-02		–	
	671-4795-03		–	
8920ADC	671-4796-00	basic status	Id defect, faults not reported	8900_FLOAD-CBL ³
	671-4796-01		Faults not reported	
	671-4796-02	full c&m	–	
	671-4796-03			
8920ADT	671-6326-00	full c&m	–	8900_FLOAD-CBL ³
	671-6326-01			
8920DMX	671-6291-00	full c&m	–	8900_FLOAD-CBL ³
	671-6291-01			
	671-6291-02			
	671-6291-03			
8920MUX	671-6290-00	full c&m	–	8900_FLOAD-CBL ³
	671-6290-01			

Table 6. 8900 Software Compatibility Matrix - (continued)

Model #	Assembly #	Control & Monitoring Support ¹	Control & Monitoring Notes ²	Software Update
8950DAC	671-4798-00	basic status	faults not reported	8900_FLOAD-CBL ³
	671-4798-01			
	671-4798-02	full c&m	–	
	671-4798-03			
8950ADC	671-4799-00	basic status	faults not reported	8900_FLOAD-CBL ³
	671-4799-01			
	671-4799-02	full c&m	–	
8960DEC	671-4664-00	no comm	misleading status reported	8900_FLOAD-CBL ³
	671-4664-01	full c&m	–	
	671-4664-03			
	671-4664-04			
8960ENC	671-4698-00	full c&m	–	8900_FLOAD-CBL ³
	671-4698-01			
8964DEC	671-6471-00	full c&m	Requires 8900NET v3.2.0	ftp download
8964ENC	671-6477-00	full c&m	Requires 8900NET v3.2.0	ftp download
8990ARC	671-5246-00	full c&m	–	8900_FLOAD-CBL
8981FS	671-5023-00	full c&m	–	8900_FLOAD-CBL ³
	671-5023-01			
8981NR	671-5023-10	full c&m	–	8900_FLOAD-CBL ³
8500 Series	For 8500 and 8800 Series module compatibility see Legacy Module Support on page 27.			
8800 Series				

¹ See *Control and Monitoring Support* on page 67 for definitions² See *Control and Monitoring Notes* on page 67 for definitions³ See *8900-FLOAD-CBL Assembly* on page 67 for information

Control and Monitoring Support

The following abbreviations are used to indicate the features supported or not supported by the modules listed in [Table 6](#):

- No comm — The module does not support any remote control or monitoring functions.
- Basic status — The module responds to only low-level probe from the Network module and only returns model number and description. Fault and signal presence are not reported. No control is supported.
- Full C&M — The module fully supports the control and monitoring system. The module reports status of all settings. The module can be configured remotely.

Control and Monitoring Notes

The following abbreviations are used in [Table A-6](#) to indicate performance limitations for the listed legacy modules:

- Comm problem — The module shorts out the frame communication bus. When the problem module is installed, the NET module cannot communicate with any of the modules in slots 1 through 10.
- ID defects — The module is susceptible to ESD (electro-static discharge) damage of the module ID lines. If this damage occurs, the module will be reported as faulted on the frame status page and software download will not work.
- Faults not reported — The module may not report an error to the NET module even though its fault LED is on. The LED gives the correct fault status.
- Misleading status reported — The module does not support control and monitoring but indicates through a motherboard connection that it does. This module will show up as red on the frame status page even if it is working correctly.

8900-FLOAD-CBL Assembly

Some modules require a cable assembly and software loading application for the software update process. This cable assembly and CD-ROM containing update software files can be ordered from Grass Valley. Contact your Grass Valley sales or service representative about ordering the 8900-FLOAD-CBL assembly.

Index

Numerics

25-pin adaptor [13](#)

A

agent software (SNMP) [30](#)

alarm reporting [18](#)

B

backplane [10](#)

baud rate [12](#)

block diagram [62](#)

C

cable

 crossover [14](#)

 Ethernet [14](#)

 LAN [15](#)

 RS-232 [11](#)

cable kit [11](#)

Comm 1 port [12](#)

compatibility matrix [65](#)

control panel [8](#)

controller module [9](#)

D

daemon [37](#)

default MAC address [23](#)

DIP switch [18](#)

disables [18](#)

disabling fault reports [18](#)

documentation online [2](#)

domain name server [19](#)

E

enable SNMP [30](#)

enables [18](#)

environmental [53](#)

Ethernet [14](#)

F

fan speed [18](#)

FAQ database [2](#)

fault alarms [18](#)

fault condition [26](#)

fault reports

 filtering [18](#)

faulty module [54](#)

firewall [19](#)

flow control [12](#)

frame [9](#), [53](#)

 cell [9](#)

 upgrade [7](#)

Frame Alarm [11](#)

frame ID [23](#)

frame name and location [28](#)

frame status page [23](#), [24](#)

frame status reporting [28](#)

frame types [22](#)

frequently asked questions [2](#)

FTP server [37](#)

G

gateway IP address [36](#)

Grass Valley Group website [2](#)

I

initial configuration [19](#)

Internet Explorer [22](#)

IP Address

 setting [19](#)

 storage [22](#)

J

- J102-RS-232 on Video frame 12
- J7-RS-232 on Audio frame 12

L

- LED indicators 16
- link list 24
- local area network (LAN) 8
- locate module 34

M

- MAC (machine) address 23
- module
 - installation 9
- module compatibility 65
- module slot names 34

N

- navigation 24
- NET module reboot 36
- NetConfig 19
 - feature 7
 - software updating 37
- Netscape Navigator 22
- network addresses 35
- network configuration storage 22
- network conflicts 23
- network identity 19
- network parameters 19
 - establishing 19
- network traffic delays 19
- NIM LED 16

O

- on-board configuration switches 29
- online documentation 2

P

- parity 12
- point-to-point 8, 14

- point-to-point communication 19
- power 53
- power supply 9

R

- reboot 36
- remote control 8
- repair depot 54
- report enable 18
- report enable switches 30
- RJ-45 14
- RS-232 11, 19

S

- service information 54
- slot configuration
 - saving 35
- slot memory 35
- slot status icons 25
- SMPTE Alarm BNC connector 11
- SNMP 18, 28
- software compatibility 65
- software download 37
- software download from web 2
- software updating
 - NetConfig 37
- stop bits 12
- subnet 19
- subnet mask 36
- supported features 65
- switch status 29

T

- testpoints 54
- troubleshooting 54

U

- update status 26
- updating 37
- upgrade 7
- URL 23

V

variable fan speed [18](#)

VideoFrame control panel [8](#)

voltage [53](#)

W

Web browser [22](#)

web site documentation [2](#)

web site FAQ database [2](#)

web site Grass Valley Group [2](#)

web site software download [2](#)

