

OVERVIEW

The SiliconDrive PC Card is an optimal time-to-market replacement for hard drives and flash cards or in host systems that require low power and scalable storage solutions.

SiliconDrive technology is engineered exclusively for the high performance, high reliability, and multiyear product lifecycle requirements of the Enterprise System OEM market. Typical end-market applications include broadband data and voice networks, military systems, flight system avionics, medical equipment, industrial control systems, video surveillance, storage networking, VoIP, wireless infrastructure, and interactive kiosks.

Every SiliconDrive is integrated with SiliconSystems' patented PowerArmor and patent-pending SiSMART technologies to virtually eliminate storage systems failures.

PowerArmor prevents data corruption and loss from power disturbances by integrating patented technology into every SiliconDrive.

SiSMART acts as an early warning system to eliminate unscheduled downtime by constantly monitoring and reporting the exact amount of remaining storage system useful life.

Numerous SiliconSystems' patented and patent-pending application-specific technologies can be integrated into SiliconDrive to safeguard application data and software IP. Application notes detailing these performance-enhancing options are available under NDA.

FEATURES

- Integrated PowerArmor and SiSMART technologies
- Capacity range: 32MB to 16GB
- Supports both 8-bit and 16-bit data register transfers
- Supports dual-voltage 3.3V or 5V interface
- Data reliability <1 error in 10¹⁴ bits read
- MTBF 4,000,000 hours
- ATA-3 compliant
- Industry standard Type II PC Card form factor
- RoHS 5 of 6 compliant
- Supports PIO modes 0-4 and DMA modes 0-2



[Click here](#)



[Click here](#)

SILICONSYSTEMS PROPRIETARY

This document and the information contained within it is confidential and proprietary to SiliconSystems, Inc.
All unauthorized use and/or reproduction is prohibited.

REVISION HISTORY

Document No.	Release Date	Changes
3100P-08DSR	February 2, 2009	Updated: <ul style="list-style-type: none"> "System Reliability" table and changed the name to "Reliability." "Related Documentation" table. Added: <ul style="list-style-type: none"> "Projected Operational Life Span."
3100P-05DSR	May 13, 2008	Updated: <ul style="list-style-type: none"> "Overview." SiProtect information.
SSDS04-3100P-R	January 28, 2008	Added a Note below the "DC Characteristics" table.
SSDS03-3100P-R	December 11, 2007	Updated the t_{RWD} Maximum in the "True IDE Multiword DMA Read/Write Access Timing" table.
SSDS02-3100P-R	July 25, 2007	Updated: <ul style="list-style-type: none"> Cylinder Low in the "Task File Register Specification" table. "Sample Label." Removed: <ul style="list-style-type: none"> NOP command from the "ATA Command Set" table.
SSDS01-3100P-R	February 7, 2007	Updated: <ul style="list-style-type: none"> V_{IH} symbol from 2.0 to 2.5 in the "DC Characteristics" table. "Common Memory Description and Operation" tables. Removed: <ul style="list-style-type: none"> 6GB capacity.
SSDS00-3100P-R	December 29, 2006	Minor formatting changes.

SILICONSYSTEMS PROPRIETARY

This document and the information contained within it is confidential and proprietary to SiliconSystems, Inc.
All unauthorized use and/or reproduction is prohibited.

TABLE OF CONTENTS

Overview	i
Features	i
Revision History	ii
List of Figures	vii
List of Tables	viii
Physical Specifications	1
Physical Dimensions	1
Product Specifications	2
System Performance	2
System Power Requirements	2
Reliability	3
Projected Operational Life Span	3
Product Capacity Specifications	4
Environmental Specifications	4
Electrical Specification	5
Pin Assignments	5
Signal Descriptions	7
Absolute Maximum Ratings	15
Capacitance	16
DC Characteristics	16
AC Characteristics	17
Attribute and Common Memory Read Timing	17
Attribute and Common Memory Write Timing	18
I/O Access Read Timing	19
I/O Access Write Timing	20
True IDE Read/Write Access Timing	21
True IDE Multiword DMA Read/Write Access Timing	22

SILICONSYSTEMS PROPRIETARY

This document and the information contained within it is confidential and proprietary to SiliconSystems, Inc.
All unauthorized use and/or reproduction is prohibited.

Attribute Memory Description and Operation	23
Attribute Memory Read Operations.....	23
Attribute Memory Write Operations.....	24
Attribute Memory Map.....	25
Card Information Structure.....	26
Configuration Option Register (200h).....	37
Configuration and Status Register (202h).....	38
Pin Placement Register (204h).....	39
Socket and Copy Register (206h).....	40
Common Memory Description and Operation	41
Common Memory Read Operations.....	41
Common Memory Write Operations.....	41
I/O Space Description and Operation	42
I/O Space Read Operations.....	42
I/O Space Write Operations.....	42
ATA and True IDE Register Decoding	43
Memory-Mapped Register Decoding.....	43
Independent I/O Mode Register Decoding.....	44
Primary and Secondary I/O Mapped Register Decoding.....	45
Task File Register Specification.....	46
ATA Registers.....	47
Data Register.....	47
Error Register.....	47
Feature Register.....	48
Sector Count Register.....	49
Sector Number Register.....	50
Cylinder Low Register.....	51
Cylinder High Register.....	52
Drive/Head Register.....	53

SILICONSYSTEMS PROPRIETARY

This document and the information contained within it is confidential and proprietary to SiliconSystems, Inc.
All unauthorized use and/or reproduction is prohibited.

Status Register	54
Command Register	55
Alternate Status Register	56
Device Control Register	57
Device Address Register.....	58
ATA Command Block and Set Description	59
ATA Command Set	59
Check Power Mode — 98h, E5h	61
Executive Drive Diagnostic — 90h	62
Format Track — 50h	63
Identify Drive — ECh.....	64
<i>Identify Drive — Drive Attribute Data</i>	65
Idle — 97h, E3h.....	68
Idle Immediate — 95h, E1h.....	69
Initialize Drive Parameters — 91h.....	70
Recalibrate — 1Xh	71
Read Buffer — E4h	72
Read DMA — C8h.....	73
Read Multiple — C4h	74
Read Sector — 20h, 21h.....	75
Read Long Sector(s) — 22h, 23h.....	76
Read Verify Sector(s) — 40h, 41h	77
Seek — 7Xh	78
Set Features — EFh.....	79
Set Multiple Mode — C6h	80
Set Sleep Mode — 99h, E6h.....	81
Standby — 96h, E2h	82
Standby Immediate — 94h, E0h	83
Write Buffer — E8h	84

SILICONSYSTEMS PROPRIETARY

This document and the information contained within it is confidential and proprietary to SiliconSystems, Inc.
All unauthorized use and/or reproduction is prohibited.

Write DMA — CAh	85
Write Multiple — C5h	86
Write Sector(s) — 30h, 31h.....	87
Write Long Sector(s) — 32h, 33h.....	88
Erase Sector(s) — C0h	89
Request Sense — 03h	90
Translate Sector — 87h	91
Wear-Level — F5h	92
Write Multiple w/o Erase — CDh.....	93
Write Sector(s) w/o Erase — 38h.....	94
Write Verify — 3Ch.....	95
Sales and Support	96
Part Numbering.....	96
Nomenclature	96
Part Numbers	97
Sample Label	97
Related Documentation.....	98

SILICONSYSTEMS PROPRIETARY

This document and the information contained within it is confidential and proprietary to SiliconSystems, Inc.
All unauthorized use and/or reproduction is prohibited.

LIST OF FIGURES

Figure 1: Physical Dimensions.....	1
Figure 2: Attribute and Common Memory Read Timing Diagram.....	17
Figure 3: Attribute and Common Memory Write Timing Diagram	18
Figure 4: I/O Access Read Timing Diagram	19
Figure 5: I/O Access Write Timing Diagram.....	20
Figure 6: True IDE Read/Write Access Timing Diagram	21
Figure 7: True IDE Multiword DMA Read/Write Access Timing.....	22
Figure 8: Sample Label.....	97

SILICONSYSTEMS PROPRIETARY

This document and the information contained within it is confidential and proprietary to SiliconSystems, Inc.
All unauthorized use and/or reproduction is prohibited.

LIST OF TABLES

Table 1: System Performance	2
Table 2: System Power Requirements	2
Table 3: Reliability.....	3
Table 4: Operational Life Span	3
Table 5: Product Capacity Specifications	4
Table 6: Environmental Specifications.....	4
Table 7: Pin Assignments	5
Table 8: Signal Descriptions	7
Table 9: Absolute Maximum Ratings	15
Table 10: Capacitance	16
Table 11: DC Characteristics	16
Table 12: Attribute and Common Memory Read Timing.....	17
Table 13: Attribute and Common Memory Write Timing.....	18
Table 14: I/O Access Read Timing	19
Table 15: I/O Access Write Timing	20
Table 16: True IDE Read/Write Access Timing	21
Table 17: True IDE Multiword DMA Read/Write Access Timing.....	22
Table 18: Attribute Memory Read Operations	23
Table 19: Attribute Memory Write Operations.....	24
Table 20: Attribute Memory Map.....	25
Table 21: Card Information Structure.....	26
Table 22: Configuration Option Register (200h)	37
Table 23: Configuration and Status Register (202h).....	38
Table 24: Pin Placement Register (204h).....	39
Table 25: Socket and Copy Register (206h).....	40
Table 26: Common Memory Read Operations	41
Table 27: Common Memory Write Operations	41

SILICONSYSTEMS PROPRIETARY

This document and the information contained within it is confidential and proprietary to SiliconSystems, Inc.
All unauthorized use and/or reproduction is prohibited.

Table 28: I/O Space Read Operations.....	42
Table 29: I/O Space Write Operations	42
Table 30: Memory-Mapped Register Decoding	43
Table 31: Independent I/O Mode Register Decoding.....	44
Table 32: Primary and Secondary I/O Mapped Register Decoding.....	45
Table 33: Task File Register Specification.....	46
Table 34: Error Register.....	47
Table 35: Feature Register	48
Table 36: Sector Count Register.....	49
Table 37: Sector Number Register	50
Table 38: Cylinder Low Register.....	51
Table 39: Cylinder High Register	52
Table 40: Drive/Head Register.....	53
Table 41: Status Register	54
Table 42: Command Register	55
Table 43: Alternate Status Register	56
Table 44: Device Control Register	57
Table 45: Device Address Register	58
Table 46: ATA Command Block and Set Description	59
Table 47: ATA Command Set.....	59
Table 48: Check Power Mode — 98h, E5h.....	61
Table 49: Executive Drive Diagnostic — 90h.....	62
Table 50: Format Track — 50h	63
Table 51: Identify Drive — ECh	64
Table 52: Identify Drive — Drive Attribute Data	65
Table 53: Idle — 97h, E3h	68
Table 54: Idle Immediate — 95h, E1h	69
Table 55: Initialize Drive Parameters — 91h	70
Table 56: Recalibrate — 1Xh.....	71

SILICONSYSTEMS PROPRIETARY

This document and the information contained within it is confidential and proprietary to SiliconSystems, Inc.
All unauthorized use and/or reproduction is prohibited.

Table 57: Read Buffer — E4h.....	72
Table 58: Read DMA — C8h	73
Table 59: Read Multiple — C4h.....	74
Table 60: Read Sector — 20h, 21h	75
Table 61: Read Long Sector(s) — 22h, 23h	76
Table 62: Read Verify Sector(s) — 40h, 41h.....	77
Table 63: Seek — 7Xh.....	78
Table 64: Set Features — EFh	79
Table 65: Set Features' Attributes	79
Table 66: Set Multiple Mode — C6h	80
Table 67: Set Sleep Mode — 99h, E6h	81
Table 68: Standby — 96h, E2h.....	82
Table 69: Standby Immediate — 94h, E0h	83
Table 70: Write Buffer — E8h	84
Table 71: Write DMA — CAh	85
Table 72: Write Multiple — C5h.....	86
Table 73: Write Sector(s) — 30h, 31h	87
Table 74: Write Long Sector(s) — 32h, 33h	88
Table 75: Erase Sector(s) — C0h.....	89
Table 76: Request Sense — 03h.....	90
Table 77: Extended Error Codes	90
Table 78: Translate Sector — 87h	91
Table 79: Wear-Level — F5h.....	92
Table 80: Write Multiple w/o Erase — CDh	93
Table 81: Write Sector(s) w/o Erase — 38h	94
Table 82: Write Verify — 3Ch	95
Table 83: Part Numbering Nomenclature	96
Table 84: Part Numbers.....	97
Table 85: Related Documentation	98

SILICONSYSTEMS PROPRIETARY

This document and the information contained within it is confidential and proprietary to SiliconSystems, Inc.
All unauthorized use and/or reproduction is prohibited.

PHYSICAL SPECIFICATIONS

The SiliconDrive PC Card products are offered in a Type II form factor. See ["Part Numbering"](#) on page 96 for details regarding PC Card capacities.

PHYSICAL DIMENSIONS

This section provides diagrams that describe the physical dimensions for the PC Card.

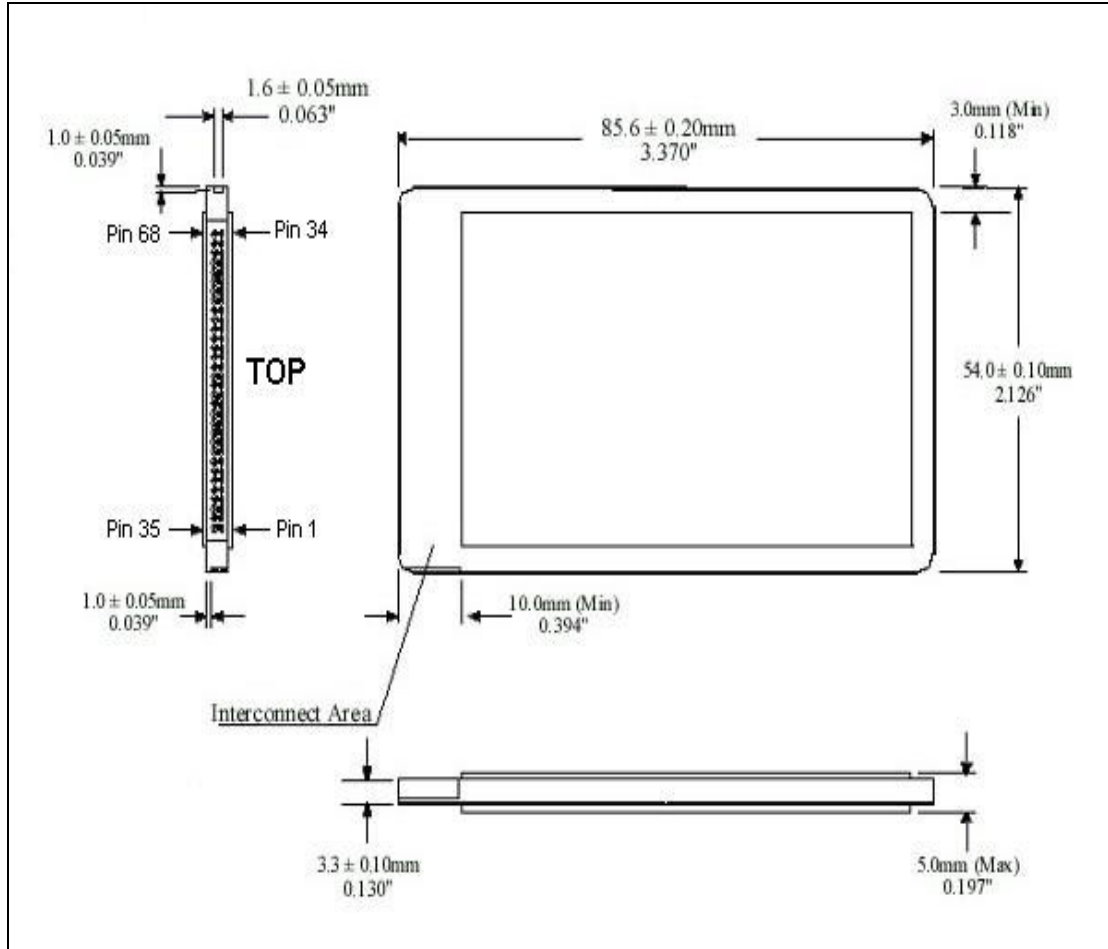

Figure 1: Physical Dimensions

SILICONSYSTEMS PROPRIETARY

This document and the information contained within it is confidential and proprietary to SiliconSystems, Inc. All unauthorized use and/or reproduction is prohibited.

PRODUCT SPECIFICATIONS

Note: All SiliconDrive PC Card values quoted are typical at 25°C and nominal supply voltage.

SYSTEM PERFORMANCE

Table 1: System Performance

Reset to Ready Startup Time (Typical/Maximum)	200ms/400ms
Read Transfer Rate (Typical)	8MBps
Write Transfer Rate (Typical)	6MBps
Burst Transfer Rate	16.7MBps
Controller Overhead (Command to DRQ)	2ms (maximum)

SYSTEM POWER REQUIREMENTS

Note: The 5V is the only operation for the 16GB capacity.

Table 2: System Power Requirements

DC Input Voltage	3.3 ± 10%	5.0 ± 10%
Sleep (Standby Current)	<0.5mA	<1.0mA
Read (Typical/Peak)	20mA/75mA	30mA/100mA
Write (Typical/Peak)	30mA/75mA	40mA/100mA

SILICONSYSTEMS PROPRIETARY

This document and the information contained within it is confidential and proprietary to SiliconSystems, Inc.
All unauthorized use and/or reproduction is prohibited.

RELIABILITY**Table 3: Reliability**

MTBF (@ 25°C)	4,000,000 hours
Bit Error Rate	<1 non-recoverable error in 10 ¹⁴ bits read

PROJECTED OPERATIONAL LIFE SPAN**Table 4: Operational Life Span**

SiliconDrive Part#	Capacity	Service Life*	GB Written per Day
SSD-P16G-3100	16GB	648.7 Years @	135.2GB
SSD-P08G-3100	8GB	324.3 Years @	135.2GB
SSD-P04G-3100	4GB	162.2 Years @	135.2GB
SSD-P02G-3100	2GB	81.1 Years @	135.2GB
SSD-P01G-3100	1GB	40.5 Years @	135.2GB
SSD-P51M-3100	512MB	20.3 Years @	135.2GB
SSD-P25M-3100	256MB	10.1 Years @	135.2GB
SSD-P12M-3100	128MB	5.1 Years @	135.2GB
SSD-P64M-3100	64MB	2.5 Years @	135.2GB
SSD-P32M-3100	32MB	1.3 Years @	135.2GB

* There are unlimited read cycles. Service life is determined using SiliconSystems' LifeEst calculation at 100% duty cycle with 25% write cycles.

LifeEst is a comprehensive measurement that considers numerous factors to determine the projected life span of a SiliconDrive. A white paper that describes the benefits of LifeEst and how to calculate it can be found at http://www.siliconsystems.com/resources/Documents/Whitepaper/SiliconSystems_NAND_Evolution.pdf.

The actual life of a SiliconDrive is dependant on the customer usage model. SiSMART is a patented technology of SiliconSystems that enables host systems to monitor actual usage of a SiliconDrive in real time. SiSMART measures and reports the remaining life of a SiliconDrive. For more information on SiSMART, refer to the *Eliminating Unscheduled Downtime by Forecasting Useable Life* white paper at http://www.siliconsystems.com/technology/pdfs/SiliconDrive_SiSMART.pdf.

SILICONSYSTEMS PROPRIETARY

This document and the information contained within it is confidential and proprietary to SiliconSystems, Inc.
All unauthorized use and/or reproduction is prohibited.

PRODUCT CAPACITY SPECIFICATIONS

Table 5: Product Capacity Specifications

Product Capacity	Capacity (Bytes)	Number of Sectors	Number of Cylinders	Number of Heads	Number of Sectors/Track
32MB	32,702,464	63,872	499	4	32
64MB	65,601,536	128,128	1001	4	32
128MB	130,154,496	254,208	993	8	32
256MB	260,571,136	508,928	994	16	32
512MB	521,773,056	1,019,088	1011	16	63
1GB	1,047,674,880	2,046,240	2030	16	63
2GB	2,098,446,336	4,098,528	4066	16	63
4GB	4,224,761,856	8,251,488	8186	16	63
8GB	8,455,200,768	16,514,064	16,383*	16	63
16GB	16,494,428,160	32,215,680	16,383*	16	63

* = All IDE drives 8GB and larger use 16383 cylinders, 16 heads, and 63 sectors/track due to interface restrictions.

ENVIRONMENTAL SPECIFICATIONS

Table 6: Environmental Specifications

Temperature	0°C to 70°C (Commercial) -40°C to 85°C (Industrial)
Humidity	8% to 95% non-condensing
Vibration	16.3gRMS, MIL-STD-810F, Method 514.5, Procedure I, Category 24
Shock	1000G, Half-sine, 0.5ms Duration 50g Pk, MIL-STD-810F, Method 516.5, Procedure I
Altitude	80,000ft, MIL-STD-810F, Method 500.4, Procedure II

SILICONSYSTEMS PROPRIETARY

This document and the information contained within it is confidential and proprietary to SiliconSystems, Inc.
All unauthorized use and/or reproduction is prohibited.

ELECTRICAL SPECIFICATION

PIN ASSIGNMENTS

The following table describes the SiliconDrive PC Card 50-pin IDE connector signals.

Table 7: Pin Assignments

Pin	PC Card Memory Mode	PC Card I/O Mode	IDE-ATA Mode	Pin	PC Card Memory Mode	PC Card I/O Mode	IDE-ATA Mode
1	GND	GND	GND	35	GND	GND	GND
2	D3	D3	D3	36	CD1#	CD1#	CD1#
3	D4	D4	D4	37	D11 ¹	D11 ¹	D11 ¹
4	D5	D5	D5	38	D12 ¹	D12 ¹	D12 ¹
5	D6	D6	D6	39	D13 ¹	D13 ¹	D13 ¹
6	D7	D7	D7	40	D14 ¹	D14 ¹	D14 ¹
7	CE1#	CE1#	CS0#	41	D15 ¹	D15 ¹	D15 ¹
8	A10	A10	A10 ²	42	CE2#	CE2#	CS1#
9	OE#	OE#	OE# ²	43	VS1#	VS1#	VS1#
10	NU	NU	NU	44	IORD#	IORD#	IORD#
11	A9	A9	A9 ²	45	IOWR#	IOWR#	IOWR#
12	A8	A8	A8 ²	46	NU	NU	NU
13	NU	NU	NU	47	NU	NU	NU
14	NU	NU	NU	48	NU	NU	NU
15	WE#	WE#	WE# ³	49	NU	NU	NU
16	RDY/BSY#	IREQ	INTRQ	50	NU	NU	NU
17	V _{CC}	V _{CC}	V _{CC}	51	V _{CC}	V _{CC}	V _{CC}
18	NU	NU	NU	52	NU	NU	NU
19	NU	NU	NU	53	NU	NU	NU
20	NU	NU	NU	54	NU	NU	NU
21	NU	NU	NU	55	NU	NU	NU
22	A7	A7	A7 ²	56	NU	NU	CSEL#
23	A6	A6	A6 ²	57	VS2#	VS2#	VS2#
24	A5	A5	A5 ²	58	RESET	RESET	RESET#
25	A4	A4	A4 ²	59	WAIT#	WAIT#	IORDY
26	A3	A3	A3 ²	60	INPACK#	INPACK#	DMARQ
27	A2	A2	A2	61	REG#	REG#	DMACK#

SILICONSYSTEMS PROPRIETARY

This document and the information contained within it is confidential and proprietary to SiliconSystems, Inc.
All unauthorized use and/or reproduction is prohibited.

Pin	PC Card Memory Mode	PC Card I/O Mode	IDE-ATA Mode	Pin	PC Card Memory Mode	PC Card I/O Mode	IDE-ATA Mode
28	A1	A1	A1	62	BVD2 ³	SPKR# ³	DASP#
29	A0	A0	A0	63	BVD1	STSCHG#	PDIAG#
30	D0	D0	D0	64	D8 ¹	D8 ¹	D8 ¹
31	D1	D1	D1	65	D9 ¹	D9 ¹	D9 ¹
32	D2	D2	D2	66	D10 ¹	D10 ¹	D10 ¹
33	WP	IOIS16#	IOCS16#	67	CD2#	CD2#	CD2#
34	GND	GND	GND	68	GND	GND	GND

Notes:

NU = Not used

1 = These signals are required only for 16-bit access, and not required when installed in 8-bit systems.

2 = Should be grounded by the host.

SILICONSYSTEMS PROPRIETARY

This document and the information contained within it is confidential and proprietary to SiliconSystems, Inc.
All unauthorized use and/or reproduction is prohibited.

SIGNAL DESCRIPTIONS

Table 8: Signal Descriptions

Signal Name	Pin	Type	Description
A10-A0	8, 10, 11, 12, 14, 15, 16, 17, 18, 19, 20	I	These address lines along with the -REG signal are used to select the following: <ul style="list-style-type: none"> The I/O port address registers within the SiliconDrive CF The memory-mapped port address registers within the SiliconDrive CF A byte in the card's information structure and its configuration control and status registers
A10-A0 (PC Card I/O mode)			This signal is the same as the PC Card Memory Mode signal.
A2-A0 (True IDE mode)	18, 19, 20	I	In true IDE mode, only A[2:0] are used to select the one of eight registers in the Task File. The remaining address lines should be grounded by the host.
BVD1 (PC Card memory mode)	46	I/O	This signal is asserted high, because BVD1 is not supported.
-STSCHG (PC Card I/O mode)			This signal is asserted low to alert the host to changes in the RDY/-BSY and Write Protect states while the I/O interface is configured. This signal's use is controlled by the Card Configuration and Status register.
-PDIAG (True IDE mode)			In the true IDE mode, this input/output is the Pass Diagnostic signal in the Master/Slave handshake protocol.
BVD2 (PC Card memory mode)	45	I/O	This signal is asserted high, as BVD2 is not supported.

SILICONSYSTEMS PROPRIETARY

This document and the information contained within it is confidential and proprietary to SiliconSystems, Inc.
All unauthorized use and/or reproduction is prohibited.

Table 8: Signal Descriptions (Continued)

Signal Name	Pin	Type	Description
-SPKR (PC Card I/O mode)			This line is the Binary Audio output from the card. If the Card does not support the Binary Audio function, this line should be held negated.
-DASP (True IDE mode)			In the true IDE mode, this input/output is the Disk Active/Slave Present signal in the Master/Slave handshake protocol.
-CD1, -CD2 (PC Card memory mode)	26, 25	O	These Card Detect pins are connected to ground on the SiliconDrive CF, and are used by the host to determine that the SiliconDrive CF is fully inserted into its socket.
-CD1, -CD2 (PC Card I/O Mode)			This signal is the same for all modes.
-CD1, -CD2 (True IDE mode)			This signal is the same for all modes.
-CE1, -CE2 (PC Card memory mode) Card Enable	7, 32	I	<p>These input signals are used both to select the card and to indicate to the card whether a byte or a word operation is being performed.</p> <ul style="list-style-type: none"> -CE2 always accesses the odd byte of the word. -CE1 accesses the even byte or the odd byte of the word depending on A0 and -CE2. <p>A multiplexing scheme based on A0, -CE1, and -CE2 allows 8-bit hosts to access all data on D0-D7. See "Attribute Memory Read Operations" on page 23, "Attribute Memory Write Operations" on page 24, "Common Memory Read Operations" on page 41, and "Common Memory Write Operations" on page 41.</p>

SILICONSYSTEMS PROPRIETARY

This document and the information contained within it is confidential and proprietary to SiliconSystems, Inc.
All unauthorized use and/or reproduction is prohibited.

Table 8: Signal Descriptions (Continued)

Signal Name	Pin	Type	Description
-CE1, -CE2 (PC Card I/O mode) Card Enable			This signal is the same as the PC Card Memory Mode signal. See " I/O Space Read Operations " on page 42 and " I/O Space Write Operations " on page 42.
-CS0, -CS1 (True IDE mode)			In the true IDE mode, -CS0 is the chip select for the task file registers while -CS1 is used to select the Alternate Status register and the Device Control register.
-CSEL (PC Card memory mode)	39	I	This signal is not used for this mode.
-CSEL (PC Card I/O mode)			This signal is not used for this mode.
-CSEL (True IDE mode)			This internally pulled-up signal is used to configure this device as a master or slave when configured in the true IDE mode. When this pin is: <ul style="list-style-type: none"> • Grounded, this device is configured as a master. • Open, this device is configured as a slave.
-INPACK (PC Card memory mode)	43	O	This signal is not used in this mode.
-INPACK (PC Card I/O mode) Input Acknowledge			This signal is asserted by the SiliconDrive CF when the card is selected and responding to an I/O read cycle at the address that is on the address bus. This signal is used by the host to control the enabling of any input data buffers between the SiliconDrive CF and the CPU.

SILICONSYSTEMS PROPRIETARY

This document and the information contained within it is confidential and proprietary to SiliconSystems, Inc.
All unauthorized use and/or reproduction is prohibited.

Table 8: Signal Descriptions (Continued)

Signal Name	Pin	Type	Description
DMARQ (True IDE mode)	43	O	In true IDE mode, this signal is used for DMA transfers between the host and device. DMARQ is asserted by the device when the device is ready to transfer data to/from the host. The direction of data transfer is controlled by -IORD and -IOWR. This signal is used in a handshake manner with -DMACK (i.e., the device waits until the host asserts -DMACK before negating DMARQ, and reasserts DMARQ if there is more data to transfer). The DMARQ/-DMACK handshake is used to provide flow control during the transfer.
D15-D00 (PC Card memory mode)	31, 30, 29, 28, 27, 49, 48, 47, 6, 5, 4, 3, 2, 23, 22, 21	I/O	These lines carry the data, commands, and status information between the host and the controller. <ul style="list-style-type: none"> D00 is the LSB of the word's even byte. D08 is the LSB of the word's odd byte.
D15-D00 (PC Card I/O mode)			This signal is the same as the PC Card Memory Mode signal.
D15-D00 (True IDE mode)			In true IDE mode, all Task File operations occur in byte mode on the low-order bus D00-D07, while all data transfers are 16 bits using D00-D15.
GND (PC Card memory mode)	1, 50	-	Ground.
GND (PC Card I/O mode)			This signal is the same for all modes.
GND (True IDE mode)			This signal is the same for all modes.

SILICONSYSTEMS PROPRIETARY

This document and the information contained within it is confidential and proprietary to SiliconSystems, Inc.
All unauthorized use and/or reproduction is prohibited.

Table 8: Signal Descriptions (Continued)

Signal Name	Pin	Type	Description
-IORD (PC Card memory mode)	34	I	This signal is not used in this mode.
-IORD (PC Card I/O mode)			This is an I/O read strobe generated by the host. This signal gates I/O data onto the bus from the SiliconDrive CF when the card is configured to use the I/O interface.
-IORD (True IDE mode)			In true IDE mode, this signal has the same function as the PC Card I/O mode.
-IOWR (PC Card memory mode)	35	I	This signal is not used in this mode.
-IOWR (PC Card I/O mode)			The I/O write strobe pulse is used to clock I/O data on the Card data bus into the SiliconDrive CF controller registers when the SiliconDrive CF is configured to use the I/O interface. The clocking occurs on the negative-to-positive edge of the signal (the trailing edge).
-IOWR (True IDE mode)			In true IDE mode, this signal has the same function as the PC Card I/O mode.
-OE (PC Card memory mode)	9	I	This is an output enable strobe generated by the host interface, which is used to read: <ul style="list-style-type: none"> • Data from the SiliconDrive CF in memory mode. • The CIS and configuration registers.
-OE (PC Card I/O mode)			In PC Card I/O mode, this signal is used to read the CIS and configuration registers.

SILICONSYSTEMS PROPRIETARY

This document and the information contained within it is confidential and proprietary to SiliconSystems, Inc.
All unauthorized use and/or reproduction is prohibited.

Table 8: Signal Descriptions (Continued)

Signal Name	Pin	Type	Description
-ATA SEL (True IDE mode)			To enable true IDE mode, this input should be grounded by the host.
-RDY/-BSY (PC Card memory mode)	37	O	<p>In memory mode, this signal is:</p> <ul style="list-style-type: none"> • Set high when the SiliconDrive CF is ready to accept a new data transfer operation. • Held low when the card is busy. <p>The host memory card socket must provide a pull-up resistor.</p> <p>At power-up and reset, the RDY/-BSY signal is held low (busy) until the SiliconDrive CF has completed its power-up or reset function. No access of any type should be made to the SiliconDrive CF during this time. The RDY/-BSY signal is held high (disabled from being busy) whenever the SiliconDrive CF has been powered up with +RESET continuously disconnected or asserted.</p>
-IREQ (PC Card I/O mode) Input Acknowledge			I/O Operation. After the SiliconDrive CF has been configured for I/O operation, this signal is used as -Interrupt Request. This line is strobed low to generate a pulse mode interrupt or held low for a level mode interrupt.
-IREQ (True IDE mode)			In true IDE mode, this signal is the active high Interrupt Request to the host.

SILICONSYSTEMS PROPRIETARY

This document and the information contained within it is confidential and proprietary to SiliconSystems, Inc.
All unauthorized use and/or reproduction is prohibited.

Table 8: Signal Descriptions (Continued)

Signal Name	Pin	Type	Description
-REG (PC Card memory mode) Attribute Memory Select	44	I	This signal is used during memory cycles to distinguish between common memory and register (attribute) memory accesses. This signal is set: <ul style="list-style-type: none"> • High for common memory. • Low for attribute memory.
-REG (PC Card I/O mode)			The signal must also be active (low) during I/O cycles when the I/O address is on the bus.
-DMACK (True IDE mode)			In true IDE mode, this signal is used by the host in response to DMARQ to initiate DMA transfers. The DMARQ/-DMACK handshake is used to provide flow control during the transfer. When -DMACK is asserted, -CS0 and -CS1 are not asserted and transfers are 16-bits wide.
-RESET (PC Card memory mode)	41	I	When the pin is high, this signal resets the SiliconDrive CF. The SiliconDrive CF is reset only at power-up if this pin is left high or open from power-up. The SiliconDrive CF is also reset when the Soft Reset bit in the Card Configuration Option register is set.
-RESET (PC Card I/O mode)			This signal is the same as the PC Card Memory Mode signal.
-RESET (True IDE mode)			In the true IDE mode, this input pin is the active low hardware reset from the host.
V _{CC} (PC Card memory mode)	13, 38	-	+5V, +3.3V power.

SILICONSYSTEMS PROPRIETARY

This document and the information contained within it is confidential and proprietary to SiliconSystems, Inc.
All unauthorized use and/or reproduction is prohibited.

Table 8: Signal Descriptions (Continued)

Signal Name	Pin	Type	Description
V _{CC} (PC Card I/O mode)			This signal is the same for all modes.
V _{CC} (True IDE mode)			This signal is the same for all modes.
-VS1, -VS2	33, 40	O	Voltage Sense Signals. <ul style="list-style-type: none"> -VS1 is grounded so that the SiliconDrive CF CIS can be read at 3.3V. -VS2 is reserved by PC Card for a secondary voltage.
-VS1, -VS2 (PC Card I/O mode)			This signal is the same for all modes.
-VS1, -VS2 (True IDE mode)			This signal is the same for all modes.
-WAIT (PC Card memory mode)	42	O	The -WAIT signal is driven low by the SiliconDrive CF to signal the host to delay completion of a memory or I/O cycle that is in progress.
-WAIT (PC Card I/O mode)			This signal is the same as the PC Card Memory Mode signal.
-IORDY (True IDE mode)			In true IDE mode, this output signal may be used as IORDY.
-WE (PC Card memory mode)	36	I	This is a signal driven by the host and used for strobing memory write data to the registers of the SiliconDrive CF when the card is configured in the memory interface mode. This signal is also used for writing the configuration registers.
-WE (PC Card I/O mode)			In PC Card I/O mode, this signal is used for writing the configuration registers.

SILICONSYSTEMS PROPRIETARY

This document and the information contained within it is confidential and proprietary to SiliconSystems, Inc.
All unauthorized use and/or reproduction is prohibited.

Table 8: Signal Descriptions (Continued)

Signal Name	Pin	Type	Description
-WE (True IDE mode)			In true IDE mode, this input signal is not used and should be connected to V_{CC} by the host.
WP (PC Card memory mode)	24	O	Write Protect Memory Mode. The SiliconDrive CF does not have a write protect switch. This signal is held low after the completion of the reset initialization sequence.
-IOIS16 (PC Card I/O mode)			I/O Operation. When the SiliconDrive CF is configured for I/O operation, pin 24 is used for the -I/O Selected, which is a 16-bit port (-IOIS16) function. A low signal indicates that a 16-bit or odd byte only operation can be performed at the addressed port.
-IOIS16 (True IDE mode)			In true IDE mode, this output signal is asserted low when this device is expecting a word data transfer cycle.

ABSOLUTE MAXIMUM RATINGS**Table 9: Absolute Maximum Ratings**

Symbol	Parameter	Minimum	Maximum	Units
T_s	Storage Temperature	-55	125	°C
T_A	Operating Temperature	-40	85	°C
V_{CC}	V_{CC} with Respect to GND	-0.3	6.7	V
V_{in}	Input Voltage	-0.5	3.8	V
V_{out}	Output Voltage	-0.3	3.6	V

SILICONSYSTEMS PROPRIETARY

This document and the information contained within it is confidential and proprietary to SiliconSystems, Inc.
All unauthorized use and/or reproduction is prohibited.

CAPACITANCE

Table 10: Capacitance

Symbol	Parameter	Maximum	Units
C_{in}	Input Capacitance	35	pF
C_{out}	Output Capacitance	35	pF
$C_{I/O}$	Bidirectional Capacitance	35	pF

DC CHARACTERISTICS

Table 11: DC Characteristics

Symbol	Parameter	3.3 V $\pm 10\%$		5V $\pm 10\%$		Units
		Minimum	Maximum	Minimum	Maximum	
V_{CC}	Power Supply Voltage	3.0	3.6	4.5	5.5	V
I_{LI}	Input Leakage *(1) Current	-	5	-	5	μA
I_{LO}	Output Leakage *(1) Current	-	5	-	5	μA
V_{CCR}	V_{CC} Read Current	-	50	-	80	mA
V_{CCW}	V_{CC} Write Current	-	50	-	80	mA
V_{CCS}	V_{CC} Standby Current	-	0.3	-	0.5	mA
V_{IL}	Input Low Voltage	-0.3	$0.3 \times V_{CC}$	-0.3	$0.3 \times V_{CC}$	V
V_{IH}	Input High Voltage	$.7 \times V_{CC}$	$V_{CC} + 0.3$	$.7 \times V_{CC}$	$V_{CC} + 0.3$	V
V_{OL}	Output Low Voltage	-	0.4	-	0.4	V
V_{OH}	Output High Voltage	$V_{CC} - 0.4$	-	$V_{CC} - 0.4$	-	V

*(1) Except the pulled-up/pulled-down pin.

SILICONSYSTEMS PROPRIETARY

This document and the information contained within it is confidential and proprietary to SiliconSystems, Inc.
All unauthorized use and/or reproduction is prohibited.

AC CHARACTERISTICS

Attribute and Common Memory Read Timing

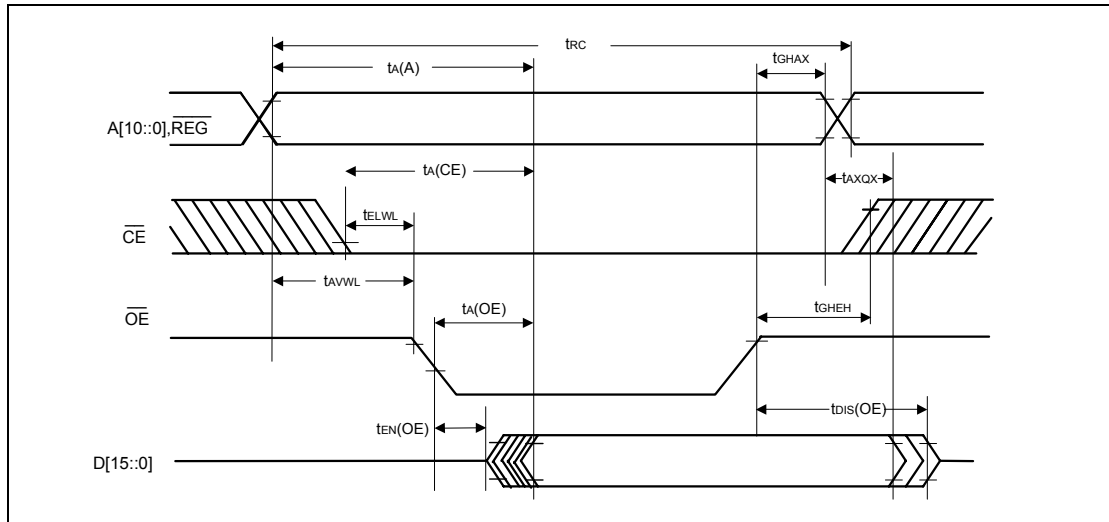

Figure 2: Attribute and Common Memory Read Timing Diagram

Table 12: Attribute and Common Memory Read Timing

Symbol	Parameter	Minimum	Maximum	Units
t_{RC}	Read Cycle Time	100	-	ns
$t_{A(A)}$	Address Access Time	-	100	ns
$t_{A(CE)}$	Card Enable Access Time	-	100	ns
$t_{A(OE)}$	Output Enable Access Time	-	50	ns
$t_{DIS(OE)}$	Output Disable Time from OE	-	50	ns
$t_{EN(OE)}$	Output Enable Time from OE	5	-	ns
t_{AXQX}	Data Valid from Address Change	0	-	ns
t_{AVWL}	Address Setup Time	10	-	ns
t_{AXQX}	Address Hold Time	15	-	ns
t_{ELWL}	Card Enable Setup Time before OE	0	-	ns
t_{GHEH}	Card Enable Hold Time following OE	15	-	ns

SILICONSYSTEMS PROPRIETARY

This document and the information contained within it is confidential and proprietary to SiliconSystems, Inc.
All unauthorized use and/or reproduction is prohibited.

Attribute and Common Memory Write Timing

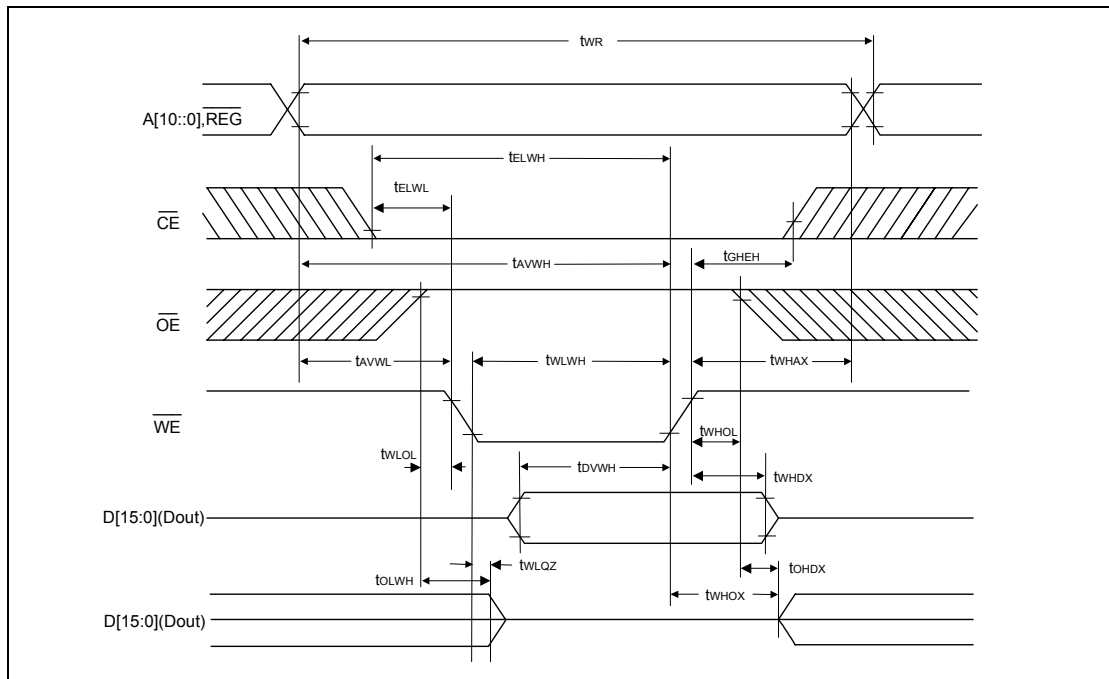

Figure 3: Attribute and Common Memory Write Timing Diagram

Table 13: Attribute and Common Memory Write Timing

Symbol	Parameter	Minimum	Maximum	Units
t_{WR}	Write Cycle Time	100	-	ns
t_{WLWH}	Write Pulse Width	60	-	ns
t_{AVWL}	Address Setup Time	10	-	ns
t_{AVWH}	Address Setup Time for WE	70	-	ns
t_{ELWH}	Card Enable Setup Time for WE	70	-	ns
t_{WHDX}	Data Hold Time	10	-	ns
t_{WHAX}	Write Recover Time	15	-	ns
t_{WLQZ}	Output Disable Time from WE	-	75	ns
t_{OLWH}	Output Disable Time from OE	-	100	ns
t_{WHOX}	Output Enable Time from WE	5	-	ns
t_{OHDX}	Output Enable Time from OE	5	-	ns
t_{WLOL}	Output Enable Setup for WE	10	-	ns
t_{WHOL}	Output Enable Hold from WE	10	-	ns
t_{ELWL}	Card Enable Setup Time before WE	0	-	ns
t_{GHEH}	Card Enable Hold Time from WE	15	-	ns
t_{DVWH}	Data Setup Time	40	-	ns

SILICONSYSTEMS PROPRIETARY

This document and the information contained within it is confidential and proprietary to SiliconSystems, Inc.
All unauthorized use and/or reproduction is prohibited.

I/O Access Read Timing

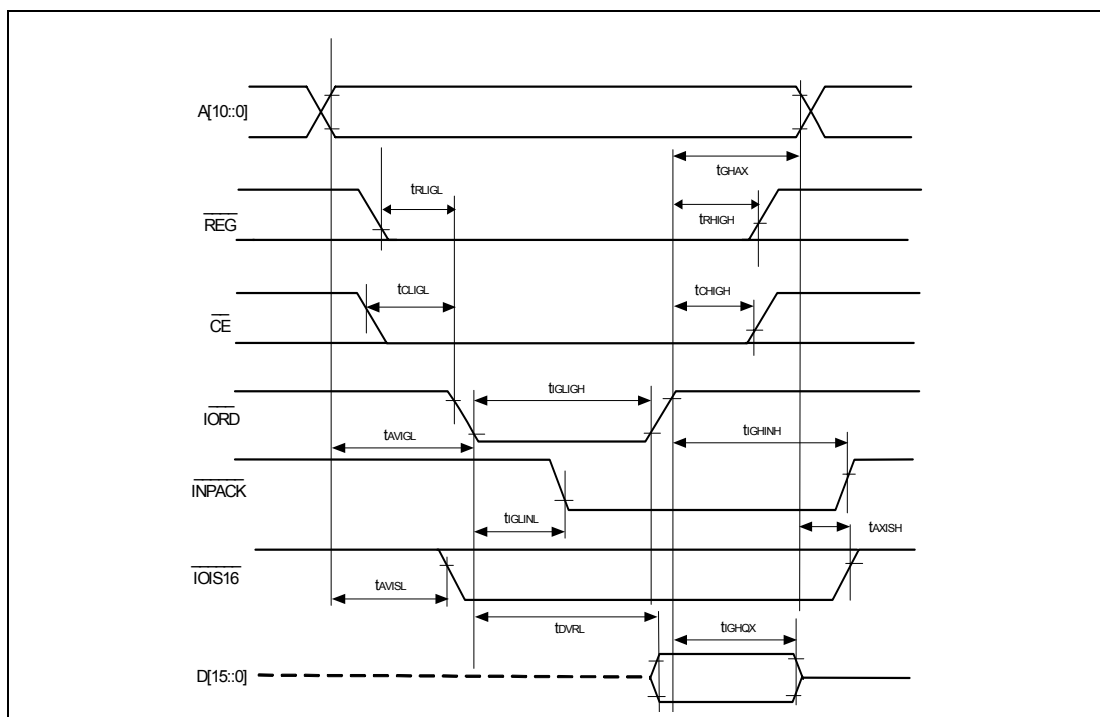

Figure 4: I/O Access Read Timing Diagram

Table 14: I/O Access Read Timing

Symbol	Parameter	Minimum	Maximum	Units
t_{DVRL}	Data Delay after IORD	-	50	ns
t_{GHQX}	Data Hold following IORD	5	-	ns
t_{GLIGH}	IORD Pulse Width	65	-	ns
t_{AVIGL}	Address Setup before IORD	25	-	ns
t_{GHAX}	Address Hold following IORD	10	-	ns
t_{CLIGL}	CE Setup before IORD	5	-	ns
t_{CHIGH}	CE Hold following IORD	10	-	ns
t_{RLIGL}	REG Setup before IORD	5	-	ns
t_{RHIGH}	REG Hold following IORD	0	-	ns
t_{GLINL}	INPACK Delay falling from IORD	-	(1)	ns
t_{GLINH}	INPACK Delay Rising from IORD	-	(1)	ns
t_{AVISL}	IOIS16 Delay Falling from Address	-	(1)	ns
t_{AXISH}	IOIS16 Delay Rising from Address	-	(1)	ns

Note: (1) IOIS16 and INPACK are not supported.

SILICONSYSTEMS PROPRIETARY

This document and the information contained within it is confidential and proprietary to SiliconSystems, Inc.
All unauthorized use and/or reproduction is prohibited.

I/O Access Write Timing

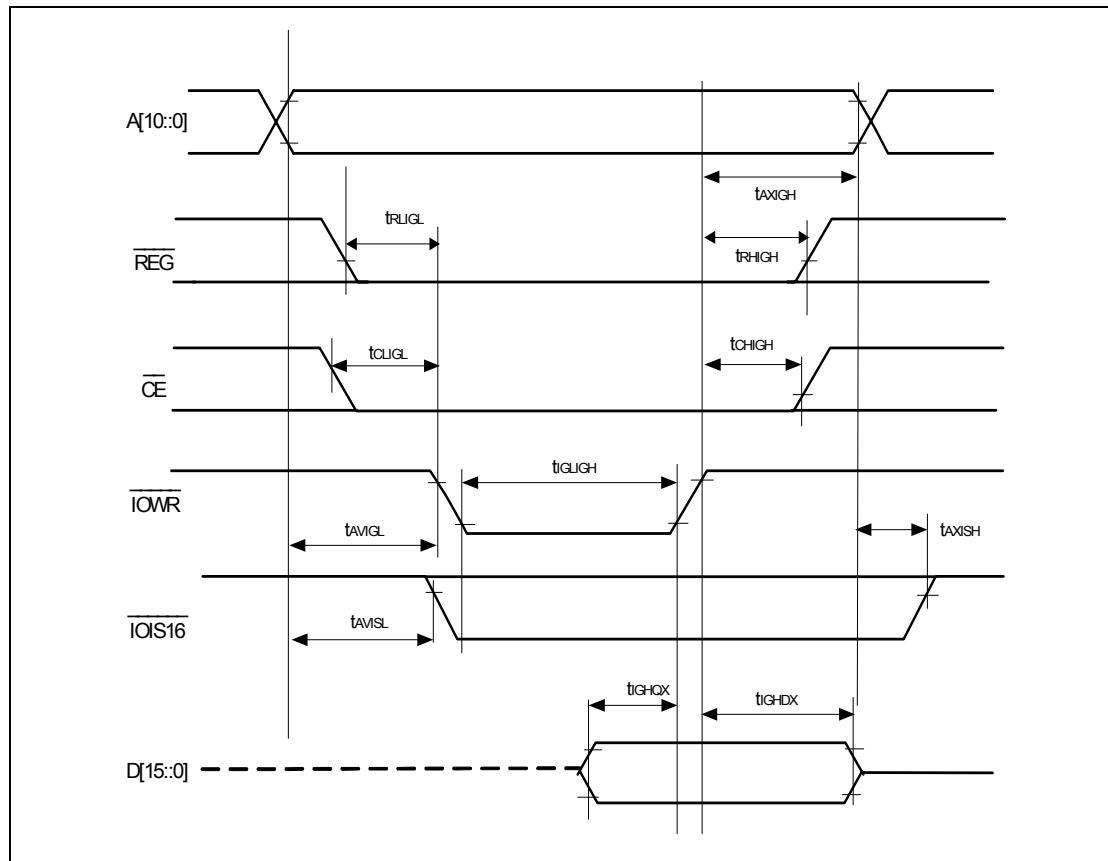

Figure 5: I/O Access Write Timing Diagram

Table 15: I/O Access Write Timing

Symbol	Parameter	Minimum	Maximum	Units
t_{IGHDX}	Data Hold following IOWR	5	-	ns
t_{IGHQX}	Data Setup before IOWR	20	-	ns
t_{IGLIGH}	IOWR Pulse Width	65	-	ns
t_{AVIGL}	Address Setup before IOWR	25	-	ns
t_{AXIGH}	Address Hold following IOWR	10	-	ns
t_{CLIGL}	CE Setup before IOWR	5	-	ns
t_{CHIGH}	CE Hold following IOWR	10	-	ns
t_{RLIGL}	REG Setup before IOWR	5	-	ns
t_{RHIGH}	REG Hold following IOWR	0	-	ns
t_{AVISL}	IOIS16 Delay Falling from Address	-	(1)	ns
t_{AXISH}	IOIS16 Delay Rising from Address	-	(1)	ns

Note: (1) IOIS16 and INPACK are not supported.

SILICONSYSTEMS PROPRIETARY

This document and the information contained within it is confidential and proprietary to SiliconSystems, Inc.
All unauthorized use and/or reproduction is prohibited.

True IDE Read/Write Access Timing

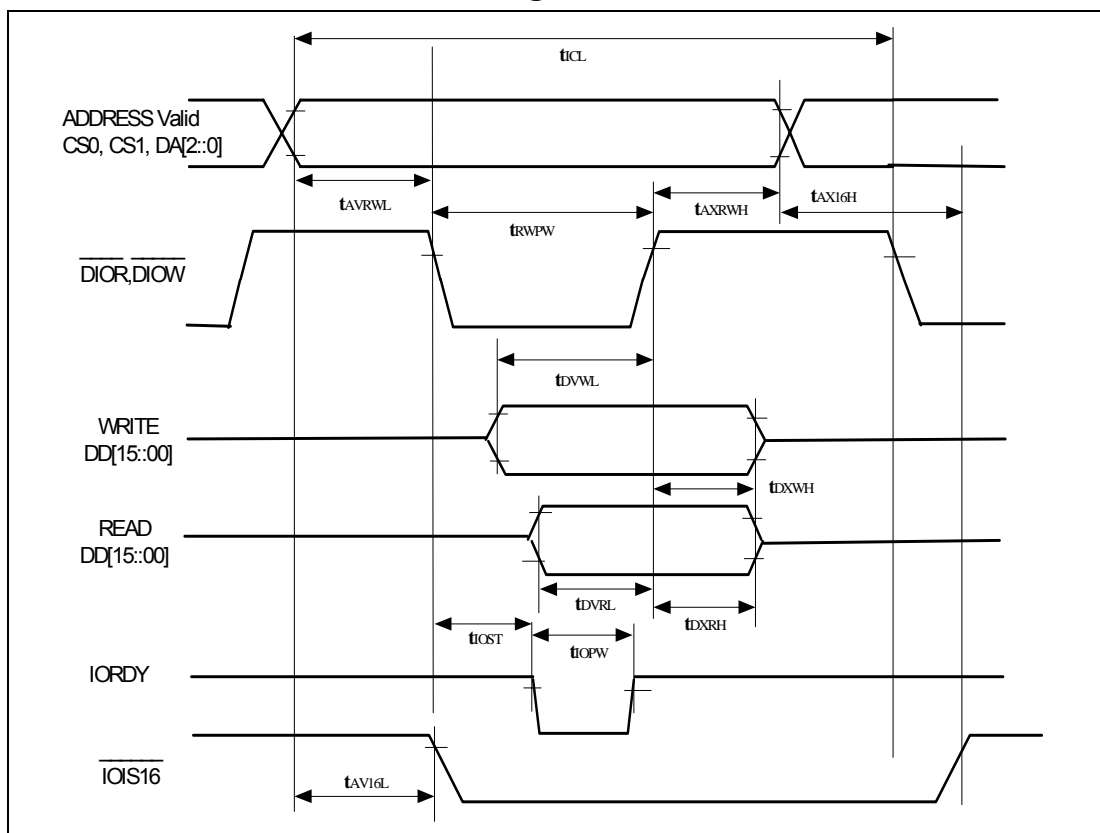

Figure 6: True IDE Read/Write Access Timing Diagram

Table 16: True IDE Read/Write Access Timing

Symbol	Parameter	Minimum	Maximum	Units
t_{ICL}	Cycle Time	100	-	ns
t_{AVRWL}	Address Valid to DIOR, DIOW Setup Time	15	-	ns
t_{RWPW}	DIOR, DIOW Pulse Width	65	-	ns
t_{DVWL}	DIOW Data Setup Time	20	-	ns
t_{DXWH}	DIOW Data Hold Time	5	-	ns
t_{DVRL}	DIOR Data Setup Time	15	-	ns
t_{DXRH}	DIOR Data Hold Time	5	-	ns
t_{AV16L}	Address Valid to IOCS16 Assertion	-	(1)	ns
t_{AX16H}	Address Valid to IOCS16 Negation	-	(1)	ns
t_{AXRWH}	DIOW, DIOR to Address Valid Hold Time	10	-	ns
t_{IOST}	IORDY Setup Time	-	(1)	ns
t_{IOPW}	IORDY Pulse Width	-	(1)	ns

Note: (1) IOIS16 and INPACK are not supported.

SILICONSYSTEMS PROPRIETARY

This document and the information contained within it is confidential and proprietary to SiliconSystems, Inc.
All unauthorized use and/or reproduction is prohibited.

True IDE Multiword DMA Read/Write Access Timing

This function does not apply to SiliconDrives that have DMA disabled.

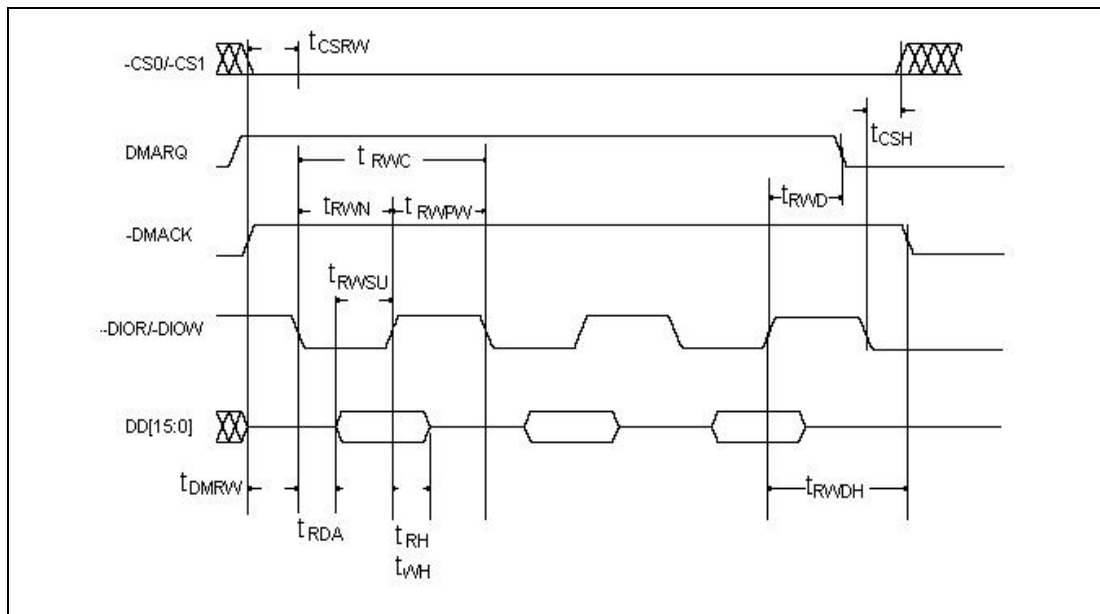

Figure 7: True IDE Multiword DMA Read/Write Access Timing

Table 17: True IDE Multiword DMA Read/Write Access Timing

Symbol	Parameter	Minimum	Maximum	Units
t_{RWC}	Cycle Time (mode 2)	100	-	ns
t_{RWPW}	DIOR/DIOW Pulse Width	65	-	ns
t_{RDA}	DIOR Data Access	-	50	ns
t_{RWSU}	DIOR/DIOW Data Setup Time	15	-	ns
t_{WH}	DIOW Data Hold Time	5	-	ns
t_{RH}	DIOR Data Hold Time	5	-	ns
t_{DMRW}	DMACK to DIOR/DIOW Setup Time	0	-	ns
t_{RWDH}	DIOR/DIOW to DMACK Hold Time	5	-	ns
t_{RWN}	DIOR/DIOW negated Pulse Width	25	-	ns
t_{RWD}	DIOR/DIOW to DMARQ Delay	-	35	ns
t_{CSRW}	CS(1:0) valid to DIOR/DIOW	10	-	ns
t_{CSH}	CS(1:0) Hold Time	10	-	ns

SILICONSYSTEMS PROPRIETARY

This document and the information contained within it is confidential and proprietary to SiliconSystems, Inc.
All unauthorized use and/or reproduction is prohibited.

ATTRIBUTE MEMORY DESCRIPTION AND OPERATION

The attribute memory plane can be read or written to by asserting the REG# signal, qualified by the appropriate combination of CE1#, OE#, and WE#. An attribute memory map describing the type and location of the information maintained in the attribute memory plane is provided in ["Attribute Memory Map" on page 25](#).

With respect to SiliconDrive CF, attribute memory consists of two sections:

- Card Information Structure (CIS), which contains a description of the Card's capabilities and specifications.
- Function Configuration Registers (FCRs), which consists of four registers, that can be read or written to by a host to configure the Card for specific purposes.

ATTRIBUTE MEMORY READ OPERATIONS

Attribute memory read operations are enabled by asserting REG#, OE#, and CE1# low. Odd byte read operations from the attribute memory plane are not valid.

Table 18: Attribute Memory Read Operations

Function Mode	REG#	CE1#	CE2#	A0	OE#	WE#	D[15:8]	D[7:0]
Standby	L	H	H	X	X	X	High-Z	High-Z
Byte Access	L	L	H	L	L	H	High-Z	Even
	L	H	L	H	L	H	High-Z	Not Valid
Word Access	L	L	L	X	L	H	Not Valid	Even
Odd Byte Only Access	L	L	H	X	H	H	Not Valid	High-Z

SILICONSYSTEMS PROPRIETARY

This document and the information contained within it is confidential and proprietary to SiliconSystems, Inc.
All unauthorized use and/or reproduction is prohibited.

ATTRIBUTE MEMORY WRITE OPERATIONS

Attribute memory write operations are enabled by asserting REG#, WE#, and CE1# low. Odd byte write operations from the attribute memory plane are not valid.

Table 19: Attribute Memory Write Operations

Function Mode	REG#	CE1#	CE2#	A0	OE#	WE#	D[15:8]	D[7:0]
Standby	L	H	H	X	X	X	High-Z	High-Z
Byte Access	L	L	H	L	H	L	High-Z	Even
	L	H	L	H	H	L	High-Z	Not Valid
Word Access	L	L	L	X	H	L	Not Valid	Even
Odd Byte Only Access	L	L	H	X	H	H	Not Valid	High-Z

SILICONSYSTEMS PROPRIETARY

This document and the information contained within it is confidential and proprietary to SiliconSystems, Inc.
All unauthorized use and/or reproduction is prohibited.

ATTRIBUTE MEMORY MAP

As stated earlier, the Attribute Memory plane is comprised of two components, the CIS and the FCRs. The following tables detail the type, location, and read/write requirements for each of the four FCRs maintained in the attribute memory plane.

Table 20: Attribute Memory Map

Register	Operation	Addr	CE1#	REG#	WE#	OE#
Card Information Structure	Read	X	0	0	1	0
	Write	X	0	0	0	1
Configuration Option	Read	200h	0	0	1	0
	Write	200h	0	0	0	1
Card Configuration and Status	Read	202h	0	0	1	0
	Write	202h	0	0	0	1
Pin Replacement	Read	204h	0	0	1	0
	Write	204h	0	0	0	1
Socket and Copy	Read	206h	0	0	1	0
	Write	206h	0	0	0	1

SILICONSYSTEMS PROPRIETARY

This document and the information contained within it is confidential and proprietary to SiliconSystems, Inc.
All unauthorized use and/or reproduction is prohibited.

CARD INFORMATION STRUCTURE

The CIS is data that describes the SiliconDrive CF, and is described by the CFA standard. This information can be used by the host system to determine a number of things about the Card that has been inserted. For information regarding the exact nature of this data and how to design the host software to interpret it, refer to the *PC Card Standard Metaformat Specification*.

Table 21: Card Information Structure

Attribute Offset	Data	7	6	5	4	3	2	1	0	Description of Contents	CIS Function
00h	01h	CISTPL_DEVICE								Device information tuple	Tuple code
02h	03h	-								Link length is 3 bytes	Link to next tuple
04h	D9h	Device Type Code Dh = I/O			W 1	Device Speed 1				<ul style="list-style-type: none"> I/O device No WP Speed = 100ns 	<ul style="list-style-type: none"> Device ID WPS Device speed
06h	01h	1X			2K			2KB of address space		Device size	
08h	FFh	List End Marker								End of device	END marker
0Ah	1Ch	CISTPL_DEVICE_OC								Other conditions device in tuple code	Tuple code
0Ch	04h	TPL_LINK								Link length is 4 bytes	Link to next tuple
0Eh	02h	EXT Reserved V _{CC} MWAIT								3V, wait is Not Used	Other conditions information field
10h	D9h	Device Type			W P S	Device Speed				<ul style="list-style-type: none"> Device type = DH: I/O Device WPS = 1: No WP Device speed = 1: 250ns 	-
12h	01h	1x			2K units			2KB of address space		Device size	
14h	FFh	List End Marker								End of device	End marker
16h	18h	CISTPL_JEDEC_C								JEDEC ID common memory	Tuple code
18h	02h	TPL_LINK								Link length is 2 bytes	Link to next tuple
1Ah	DFh	PCMCIA Manufacturer's JEDEC								Manufacturer's ID code	- JEDEC ID
1Ch	01h	PCMCIA JEDEC Device Code								Second byte of JEDEC ID	-
1Eh	20h	CISTPL_MANFID								Manufacturer's ID code	Tuple code
20h	04h	TPL_LINK								-	-
22h	00h	Low Byte of PCMCIA Manufacturer's Code								JEDEC manufacturer's ID	Low byte of manufacturer's code
24h	00h	High Byte of PCMCIA Manufacturer's Code								Code of 0, because the other byte is the JEDEC 1 byte manufacturer's ID	High byte of the manufacturer's code
26h	00h	Low Byte of Product Code								Manufacturer's code for SiliconDrive CF	Low byte of the product code
28h	00h	High Byte of Product Code								Manufacturer's code for SiliconDrive CF	High byte of the product code
2Ah	21h	CISTPL_FUNCID								Function ID tuple	Tuple code
2Ch	02h	TPL_LINK								Link length is 2 bytes	Link to next tuple

SILICONSYSTEMS PROPRIETARY

This document and the information contained within it is confidential and proprietary to SiliconSystems, Inc. All unauthorized use and/or reproduction is prohibited.

Table 21: Card Information Structure (Continued)

Attribute Offset	Data	7	6	5	4	3	2	1	0	Description of Contents	CIS Function
2Eh	04h	TPLFID_FUNCTION = 04H								Disk function, which may be silicon or removable	PC Card function code
30h	01h	Reserved			R	P				<ul style="list-style-type: none"> R = 0: No BIOS ROM P = 1: Configure card at power-on 	System initialization byte
32h	22h	CISTPL_FUNCE								Function extension tuple	Tuple code
34h	02h	TPL_LINK								Link length is 2 bytes	Link to next tuple
36h	01h	Disk Function Extension Tuple Type								Disk interface type	Extension tuple type for disk
38h	01h	Disk Interface Type								PC Card interface type	Interface type
3Ah	22h	CISTPL_FUNCE								Function extension tuple	Tuple code
3Ch	03h	TPL_LINK								Link length is 3 bytes	Link to next tuple
3Eh	02h	Disk Function Extension Tuple Type								Basic PCMCIA-ATA extension tuple	Extension tuple type for disk
40h	04h	Reserved			D	U	S	V		No Vpp, silicon, single drive <ul style="list-style-type: none"> V = 0: No Vpp required S = 0: Silicon U = 1: Unique serial number D = 0: Single drive on Card 	Basic ATA option parameters byte 1
42h	07h	R	I	E	N	P3	P2	P1	P0	<ul style="list-style-type: none"> P0: Sleep mode supported P1: Standby mode supported P2: Idle mode supported P3: Drive auto power control N: Some configuration excludes 3X7 E: Index bit is emulated I: Twin IOIS16# data register only R: Reserved 	Basic ATA option parameters byte 2
44h	1Ah	CISTPL_CONFIG								Configuration tuple	Tuple code
46h	05h	TPL_LINK								Link length is 5 bytes	Link to next tuple
48h	01h	RAS		RMS		RAS		-		<ul style="list-style-type: none"> RFS: Reserved RMS: TPCC RMSK size -1 = 0 RAS: TPCC_RADR size -1 = 1 1-byte register mask 2-byte configuration base address 	Size of fields byte TPCC_SZ
4Ah	07h	TPCC_LAST								Entry with configuration index of 7 is final entry in table	Last entry of configuration registers
4Ch	00h	TPCC_RADR (LSB)								Configuration registers are located at 200H in REG space	Location of configuration registers
4Eh	02h	TPCC_RADR (MSB)								-	-
50h	0Fh	Reserved			S	P	C	I	-	<ul style="list-style-type: none"> I: Configuration index C: Configuration and status P: Pin replacement S: Socket and copy 	Configuration registers present mask TPCC_RMSK
52h	1Bh	CISTPL_TABLE_ENTRY								Configuration table entry tuple	Tuple code
54h	0Bh	TPL_LINK								Link length is 11 bytes	Link to next tuple

SILICONSYSTEMS PROPRIETARY

This document and the information contained within it is confidential and proprietary to SiliconSystems, Inc. All unauthorized use and/or reproduction is prohibited.

Table 21: Card Information Structure (Continued)

Attribute Offset	Data	7	6	5	4	3	2	1	0	Description of Contents	CIS Function		
56h	C0h	I	D	Configuration index						Memory-mapped I/O configuration	Configuration table index byte TPCE_INDX		
										<ul style="list-style-type: none"> I = 1: Interface byte follows D = 1: Default entry Configuration index = 0 			
58h	C0h	W	R	P	B	Interface Type					Interface description field TPCE_IF		
											<ul style="list-style-type: none"> W = 0: Wait not used R = 1: Ready active P = 0: WP used B = 0: BVD1 and BVD2 not used IF type = 0: Memory interface 		
5Ah	A1h	M	MS	IR	IO	T	P					Feature selection byte TPCE_FS	
												<ul style="list-style-type: none"> M = 1: Miscellaneous information present MS = 01: Memory space information single 2-byte length IR = 0: No interrupt information present IO = 0: No I/O port information present T = 0: No timing information present P = 1: V_{CC} only information 	
5Ch	27h	R	DI	PI	AI	SI	HV	LV	NV	Nominal voltage only follows	Power parameters for V _{CC}		
										<ul style="list-style-type: none"> R: Reserved DI: Powerdown current information PI: Peak current information AI: Average current information SI: Static current information HV: Maximum voltage information LV: Minimum voltage information NV: Nominal voltage information 			
5Eh	55h	X	Mantissa				Exponent				Nominal voltage = 5V	V _{CC} nominal value	
60h	4Dh	X	Mantissa			Exponent				V _{CC} nominal 4.5V	V _{CC} minimum value		
62h	5Dh	X	Mantissa			Exponent				V _{CC} nominal 5.5V	V _{CC} maximum value		
64h	75h	X	Mantissa			Exponent				Maximum average current over 10ms is 80mA	Maximum average current		
66h	08h	Length in 256 bytes pages (LSB)			Length of memory space is 2KB							Memory space description structures (TPCE_MS)	
68h	00h	Length in 256 bytes pages (MSB)			Length of memory space is 2KB							Memory space description structures (TPCE_MS)	
6Ah	21h	X	R	P	RO	AT	-				Miscellaneous features field TPCE_MI		
											<ul style="list-style-type: none"> X = 0: No more miscellaneous fields R: Reserved P = 1: Powerdown supported RO = 0: Not read only mode A = 0: Audio not supported T = 0: Single drive 		
6Ch	1Bh	CISTPL_TABLE_ENTRY									Configuration table entry tuple	Tuple code	
6Eh	06h	TPL_LINK									Link length is 6 bytes	Link to next tuple	

SILICONSYSTEMS PROPRIETARY

This document and the information contained within it is confidential and proprietary to SiliconSystems, Inc. All unauthorized use and/or reproduction is prohibited.

Table 21: Card Information Structure (Continued)

Attribute Offset	Data	7	6	5	4	3	2	1	0	Description of Contents	CIS Function
70h	00h	I	D	IR	IQ	T	P	-	-	Memory-mapped I/O configuration <ul style="list-style-type: none"> I = 0: No interface byte D = 0: No default entry Configuration index = 0 	Configuration table index byte TPCE_INDXX
72h	01h	M	MS	IR	IO	T	P	-	-	<ul style="list-style-type: none"> M = 0: No miscellaneous information MS = 00: No memory space information IR = 0: No interrupt information present IO = 0: No I/O port information present T = 0: No timing information present P = 1: V_{CC} only information 	Feature selection byte TPCE_FS
74h	21h	R	DI	PI	AI	SI	HV/LV/NV		-	Nominal voltage only follows <ul style="list-style-type: none"> R: Reserved DI: Powerdown current information PI: Peak current information AI: Average current information SI: Static current information HV: Maximum voltage information LV: Minimum voltage information NV: Nominal voltage information 	Power parameters for V _{CC}
76h	B5h	X	Mantissa			Exponent			-	Nominal voltage = 3.0 V	V _{CC} nominal value
78h	1Eh	Extension							-	+0.3 V	Extension byte
7Ah	4Dh	X	Mantissa			Exponent			-	Maximum average current over 10ms is 45 mA	Maximum average current
7Ch	1Bh	CISTPL_TABLE_ENTRY							-	Configuration table entry tuple	Tuple code
7Eh	0Dh	TPL_LINK							-	Link length is 10 bytes	Link to next tuple
80h	C1h	I	D	Configuration			INDEX			Contiguous I/O mapped ATA registers configuration <ul style="list-style-type: none"> I = 1: Interface byte follows D = 1: Default entry Configuration index = 1 	Configuration table index byte TPCE_INDXX
82h	41h	W	R	P	B	Interface Type				<ul style="list-style-type: none"> W = 0: Wait not used R = 1: Ready active P = 0: WP not used B = 0: BVS1 and BVD2 not used IF type = 1: I/O interface 	Interface description field TPCE_IF
84h	99h	M	MS	IR	IO	T	P	-	-	<ul style="list-style-type: none"> M = 1: Miscellaneous information present MS = 00: No memory space information IR = 1: Interrupt information present IO = 1: I/O port information present T = 0: No timing information present P = 1: V_{CC} only information 	Feature selection byte TPCE_FS

SILICONSYSTEMS PROPRIETARY

This document and the information contained within it is confidential and proprietary to SiliconSystems, Inc. All unauthorized use and/or reproduction is prohibited.

Table 21: Card Information Structure (Continued)

Attribute Offset	Data	7	6	5	4	3	2	1	0	Description of Contents	CIS Function	
86h	27h	R	DI	PI	AI	SI	HV	LV	NV	Nominal voltage only follows <ul style="list-style-type: none"> R: Reserved DI: Powerdown current information PI: Peak current information AI: Average current information SI: Static current information HV: Maximum voltage information LV: Minimum voltage information NV: Nominal voltage information 	Power parameters for V _{CC}	
88h	55h	X	Mantissa			Exponent				Nominal voltage = 5V	V _{CC} nominal value	
8Ah	4Dh	X	Mantissa			Exponent				V _{CC} nominal 4.5V	V _{CC} minimum value	
8Ch	5Dh	X	Mantissa			Exponent				V _{CC} nominal 5.5V	V _{CC} maximum value	
8Eh	75h	X	Mantissa			Exponent				Maximum average current over 10ms is 80mA	Maximum average current	
90h	64h	R	S	E	I	O	AddrLine			<ul style="list-style-type: none"> S = 1: 16-bit hosts supported E = 1: 8-bit hosts supported IO AddrLine: 4 lines decoded 	I/O space description field TPCE_IO	
92h	F0h	S	P	L	M	V	B	I	N	<ul style="list-style-type: none"> S = 1: Share logic active P = 1: Pulse mode IRQ supported L = 1: Level mode IRQ supported M = 1: Bit mask of IRQs present V = 0: No vender unique IRQ B = 0: No bus error IRQ I = 0: No IO check IRQ N = 0: No NMI 	Interrupt request description structure TPCE_IRQ	
94h	FFh	IR	IR	IR	IR	IR	IR	IR	IR	SiliconSystems recommends the IRQ level to be routed 0 to 15	Mask extension byte 1 TPCE_IRQ	
		Q	Q	Q	Q	Q	Q	Q	Q			
		7	6	5	4	3	2	1	0			
96h	FFh	IR	IR	IR	IR	IR	IR	IR	IR	SiliconSystems recommends routing to any normal, maskable IRQ.	Mask extension byte 2 TPCE_IRQ	
		Q	Q	Q	Q	Q	Q	Q	Q			
		15	14	13	12	11	10	9	8			
98h	21h	X	R	P	R	O	A	T	-	<ul style="list-style-type: none"> X = 0: No more miscellaneous fields R: Reserved P = 1: Powerdown supported RO = 0: Not read only mode A = 0: Audio not supported T = 0: Single drive 	Miscellaneous features field TPCE_MI	
9Ah	1Bh	CISTPL__TABLE_ENTRY								Configuration table entry tuple	Tuple code	
9Ch	06h	TPL_LINK								Link length is 6 bytes	Link to next tuple	
9Eh	01h	I	D	Configuration Index							Contiguous I/O mapped ATA registers configuration	Configuration table index Byte TPCE_INDX
											<ul style="list-style-type: none"> I = 0: No Interface byte D = 0: No Default entry Configuration index = 1 	

SILICONSYSTEMS PROPRIETARY

This document and the information contained within it is confidential and proprietary to SiliconSystems, Inc. All unauthorized use and/or reproduction is prohibited.

Table 21: Card Information Structure (Continued)

Attribute Offset	Data	7	6	5	4	3	2	1	0	Description of Contents	CIS Function	
A0h	01h	M	MS	IR	IO	T	P	-	-	<ul style="list-style-type: none"> M = 0: No miscellaneous information MS = 00: No memory space information IR = 0: No interrupt information present IO = 0: No I/O port information present T = 0: No timing information present P = 1: V_{CC} only information 	Feature selection byte TPCE_FS	
A2h	21h	R	DI	PI	AI	SI	HV	LV	NV	<ul style="list-style-type: none"> Nominal voltage only follows R: Reserved DI: Powerdown current information PI: Peak current information AI: Average current information SI: Static current information HV: Maximum voltage information LV: Minimum voltage information NV: Nominal voltage information 	Power parameters for V _{CC}	
A4h	B5h	X	Mantissa			Exponent					Nominal voltage = 3.0V	V _{CC} nominal value
A6h	1Eh	X	Mantissa			Exponent					+0.3V	Extension byte
A8h	4Dh	X	Mantissa			Exponent					Maximum average current over 10ms is 45mA	Maximum average current
AAh	1Bh	CISTPL_TABLE_ENTRY								Configuration table entry tuple	Extension byte	
ACh	12h	TPL_LINK								Link length is 18 bytes	Link to next tuple	
A Eh	C2h	I	D	Configuration Index							<ul style="list-style-type: none"> ATA primary I/O mapped configuration I = 1: Interface byte follows D = 1: default entry follows Configuration index = 2 	Configuration table index byte TPCE_IND _X
B0h	41h	W	R	P	B	Interface Type				<ul style="list-style-type: none"> W = 0: Wait not used R = 1: Ready active P = 0: WP not used B = 0: BVS1 and BVD2 not used IF type = 1: I/O interface 	Interface description field TPCE_IF	
B2h	99h	M	MS	IR	IO	T	P	-	-	<ul style="list-style-type: none"> M = 1: Miscellaneous information present MS = 00: No memory space information IR = 1: Interrupt information present IO = 1: I/O port information present T = 0: No timing information present P = 1: V_{CC} only information 	Feature selection byte TPCE_FS	
B4h	27h	R	DI	PI	AI	SI	HV	LV	NV	<ul style="list-style-type: none"> Nominal voltage only follows R: Reserved DI: Powerdown current information PI: Peak current information AI: Average current information SI: Static current information HV: Maximum voltage information LV: Minimum voltage information NV: Nominal voltage information 	Power parameters for V _{CC}	

SILICONSYSTEMS PROPRIETARY

This document and the information contained within it is confidential and proprietary to SiliconSystems, Inc. All unauthorized use and/or reproduction is prohibited.

Table 21: Card Information Structure (Continued)

Attribute Offset	Data	7	6	5	4	3	2	1	0	Description of Contents	CIS Function
B6h	55h	X	Mantissa			Exponent				Nominal voltage = 5V	V _{CC} nominal value
B8h	4Dh	X	Mantissa			Exponent				V _{CC} nominal 4.5V	V _{CC} minimum value
BAh	5Dh	X	Mantissa			Exponent				V _{CC} nominal 5.5V	V _{CC} maximum value
BCh	75h	X	Mantissa			Exponent				Maximum average current over 10ms is 80mA	Maximum average current
BEh	EAh	R	S	E	I	O	AddrLine			<ul style="list-style-type: none"> R = 1: Range follows S = 1: 16-bit hosts supported E = 1: 8-bit hosts supported IO AddrLines: 10 lines decoded 	I/O space description field TPCE_IO
C0h	61h	LS	AS	N Range						<ul style="list-style-type: none"> LS = 1: Size of lengths is 1 byte AS = 2: Size of address is 2 bytes N Range = 1: Address Range-1 	I/O range format description
C2h	F0h	First I/O Base Address						First I/O base address (LSB)			First I/O range address
C4h	01h	First I/O Base Address						First I/O base address (MSB)			-
C6h	07h	First I/O Base Address						First I/O length -1			First I/O range length
C8h	F6h	Second I/O Base Address						Second I/O base address (LSB)			Second I/O range address
CAh	03h	Second I/O Base Address						Second I/O base address (MSB)			
CCh	01h	Second I/O Range Length						Second I/O length -1			Second I/O range length
CEh	EEh	S	P	L	M	IRQ	Level			<ul style="list-style-type: none"> S = 1: Share logic active P = 1: Pulse mode IRQ supported L = 1: Level mode IRQ supported M = 0: Bit mask of IRQs present — IRQ level is IRQ14 	Interrupt request description structure TPCE_IR
D0h	21h	X	R	P	R	O	A	T	-	<ul style="list-style-type: none"> X = 0: No more miscellaneous fields R: Reserved P = 1: Powerdown supported RO = 0: Not read only mode A = 0: Audio not supported T = 0: Single drive 	Miscellaneous features field TPCE_MI
D2h	1Bh	CISTPL_TABLE_ENTRY						Configuration table entry tuple			Tuple code
D4h	06h	TPL_LINK						Link length is 6 bytes			Link to next tuple
D6h	02h	I	D	Configuration Index						ATA primary I/O mapped configuration	Configuration table index byte TPCE_IND _X
D8h	01h	I	D	Configuration Index						Contiguous I/O mapped ATA registers configuration	Configuration table index byte TPCE_IND _X

SILICONSYSTEMS PROPRIETARY

This document and the information contained within it is confidential and proprietary to SiliconSystems, Inc. All unauthorized use and/or reproduction is prohibited.

Table 21: Card Information Structure (Continued)

Attribute Offset	Data	7	6	5	4	3	2	1	0	Description of Contents	CIS Function	
DAh	21h	M	MS	IR	IO	T	P	-	-	<ul style="list-style-type: none"> M = 0: No miscellaneous information MS = 00: No memory space information IR = 0: No interrupt information present IO = 0: No I/O port information present T = 0: No timing information present P = 1: V_{CC} only information 	Feature selection byte TPCE_FS	
DCh	B5h	R	DI	PI	AI	SI	HV	LV	NV	<ul style="list-style-type: none"> R: Reserved DI: Powerdown current information PI: Peak current information AI: Average current information SI: Static current information HV: Maximum voltage information LV: Minimum voltage information NV: Nominal voltage information 	Power parameters for V _{CC}	
DEh	1Eh	X	Mantissa			Exponent					Nominal voltage = 3.0V	V _{CC} nominal value
E0h	4Dh	Extension								+0.3V	Extension byte	
E2h	1Bh	CISTPL_TABLE_ENTRY								Configuration table entry tuple	Tuple code	
E4h	12h	TPL_LINK								Link length is 18 bytes	Link to next tuple	
E6h	C3h	M	MS	IR	IO	T	P	-	-	<ul style="list-style-type: none"> M = 0: No miscellaneous information MS = 00: No memory space information IR = 0: No interrupt information present IO = 0: No I/O port information present T = 0: No timing information present P = 1: V_{CC} only information 	Feature selection byte TPCE_FS	
E8h	41h	R	DI	PI	AI	SI	HV	LV	NV	<ul style="list-style-type: none"> R: Reserved DI: Powerdown current information PI: Peak current information AI: Average current information SI: Static current information HV: Maximum voltage information LV: Minimum voltage information NV: Nominal voltage information 	Power parameters for V _{CC}	
EAh	99h	M	MS	IR	IO	T	P	-	-	<ul style="list-style-type: none"> M = 1: No miscellaneous information MS = 00: No Memory space information IR = 1: No interrupt information present IO = 1: No I/O port information present T = 0: No timing information present P = 01: V_{CC} only information 	Feature selection byte TPCE_FS	

SILICONSYSTEMS PROPRIETARY

This document and the information contained within it is confidential and proprietary to SiliconSystems, Inc. All unauthorized use and/or reproduction is prohibited.

Table 21: Card Information Structure (Continued)

Attribute Offset	Data	7	6	5	4	3	2	1	0	Description of Contents	CIS Function
ECh	27h	R	DI	PI	AI	SI	HV	LV	NV	Nominal voltage only follows <ul style="list-style-type: none"> R: Reserved DI: Powerdown current information PI: Peak current information AI: Average current information SI: Static current information HV: Maximum voltage information LV: Minimum voltage information NV: Nominal voltage information 	Power parameters for V _{CC}
EEh	55h	X	Mantissa			Exponent				Nominal voltage = 5V	V _{CC} nominal value
F0h	4Dh	X	Mantissa			Exponent				V _{CC} nominal 4.5V	V _{CC} minimum value
F2h	5Dh	X	Mantissa			Exponent				V _{CC} nominal 5.5V	V _{CC} maximum value
F4h	75h	X	Mantissa			Exponent				Maximum average current over 10ms is 80mA	Maximum average current
F6h	EAh	R	S	E	I	O	AddrLine			<ul style="list-style-type: none"> R = 1: Range follows S = 1: 16-bit hosts supported E = 1: 8-bit hosts supported IO AddrLines: 10 lines decoded 	I/O space description field TPCE_IO
F8h	61h	LS	AS	N Range						<ul style="list-style-type: none"> LS = 1: Size of lengths is 1 byte AS = 2: Size of address is 2 bytes N Range = 1: Address range -1 	I/O range format description
FAh	70h	-								First I/O base address (LSB)	First I/O range address
FCh	01h	-								First I/O base address (MSB)	-
FEh	07h	-								First I/O length -1	First I/O range length
100h	76h	-								Second I/O base address (LSB)	Second I/O range address
102h	03h	-								Second I/O base address (MSB)	-
104h	01h	-								Second I/O length	Second I/O range length
106h	EEh	S	P	L	M	IRQ	Level			<ul style="list-style-type: none"> S = 1: Share logic active P = 1: Pulse mode IRQ supported L = 1: Level mode IRQ supported M = 0: Bit mask of IRQs present — IRQ level is IRQ14 	Interrupt request description structure TPCE_IR miscellaneous features field TPCE_MI
108h	21h	X	R	P	R	O	A	T	-	<ul style="list-style-type: none"> X = 0: No more miscellaneous fields - R: Reserved P = 1: Powerdown supported RO = 0: Not read only mode A = 0: Audio not supported T = 0: Single drive 	
10Ah	1Bh	CISTPL_TABLE_ENTRY								Configuration table entry tuple	Tuple code
10Ch	06h	TPL_LINK								Link length is 6 bytes	Link to next tuple

SILICONSYSTEMS PROPRIETARY

This document and the information contained within it is confidential and proprietary to SiliconSystems, Inc. All unauthorized use and/or reproduction is prohibited.

Table 21: Card Information Structure (Continued)

Attribute Offset	Data	7	6	5	4	3	2	1	0	Description of Contents	CIS Function	
10Eh	03h	I	D	Configuration Index						ATA primary I/O mapped configuration	Configuration table index byte TPCE_INDx	
										<ul style="list-style-type: none"> I = 0: No interface byte D = 0: No default entry Configuration index = 2 		
110h	01h	M	MS	IR	IO	T	P		-	<ul style="list-style-type: none"> M = 0: No miscellaneous information MS = 00: No memory space information IR = 0: No interrupt information present IO = 0: No I/O port information present T = 0: No timing information present P = 1: V_{CC} only information 	Feature selection byte TPCE_FS	
112h	21h	R	DI	PI	AI	SI	HV	LV	NV	Nominal voltage only follows	Power parameters for V _{CC}	
										<ul style="list-style-type: none"> R: Reserved DI: Powerdown current information PI: Peak current information AI: Average current information SI: Static current information HV: Maximum voltage information LV: Minimum voltage information NV: Nominal voltage information 		
114h	B5h	X	Mantissa			Exponent					Nominal voltage = 3.0V	V _{CC} nominal value
116h	1Eh	Extension								+0.3V	Extension byte	
118h	4Dh	X	Mantissa			Exponent					Maximum average current over 10ms is 45mA	Maximum average current
11Ah	1Bh	CISTPL_MANFID								Manufacturer's ID code	Tuple code	
11Ch	04h	TPL_LINK								Link length is 4 bytes	Link to next tuple	
11Eh	07h	I	D	Configuration Index						AT fixed disk secondary I/O 3.3V configuration	TPCE_INDx	
120h	00h	M	MS	IR	IO	T	P		-	P: Power information type	TPCL_FS	
122h	28h	-								Manufacturer code for SiliconDrive CF	Reserved	
124h	D3h	-								Manufacturer code for SiliconDrive CF	Reserved	
126h	14h	CISTPL_NO_LINK								No link control tuple	Tuple code	
128h	00h	-								Link is 0 bytes	Link to next tuple	
12Ah	15h	CISTPL_VERS_1								Level 1 version	Tuple code	
12Ch	1Ah	TPL_LINK								Link length is 26h bytes	Link to next tuple	
12Eh	04h	TPPLV1_MAJOR								PC Card 2.0/JEIDA4.1	END marker	
130h	01h	TPPLV1_MINOR								PC Card 2.0/JEIDA4.1	Tuple code	
132h	53h	-								S	Information string	
134h	49h	-								I	-	
136h	4Ch	-								L	-	
138h	49h	-								I	-	
13Ah	43h	-								C	-	

SILICONSYSTEMS PROPRIETARY

This document and the information contained within it is confidential and proprietary to SiliconSystems, Inc. All unauthorized use and/or reproduction is prohibited.

Table 21: Card Information Structure (Continued)

Attribute Offset	Data	7	6	5	4	3	2	1	0	Description of Contents	CIS Function
13Ch	4Fh				-					O	-
13Eh	4Eh				-					N	-
140h	53h				-					S	-
142h	59h				-					Y	-
144h	53h				-					S	-
146h	54h				-					T	-
	45h				-					E	-
14Ah	4Dh				-					M	-
14Ch	53h				-					S	-
14Eh	00h				-					Space	-
150h	56h				-					V	-
152h	45h				-					E	-
154h	52h				-					R	-
156h	32h				-					2	-
158h	2Eh				-					-	-
15Ah	30h				-					0	-
15Ch	30h				-					0	-
	00h				-					-	-
160h	FFh				-					-	-

SILICONSYSTEMS PROPRIETARY

This document and the information contained within it is confidential and proprietary to SiliconSystems, Inc.
All unauthorized use and/or reproduction is prohibited.

CONFIGURATION OPTION REGISTER (200H)

The Configuration Option register is used to configure the SiliconDrive CF, define the address decoding, and initiate the software RESET sequence.

Table 22: Configuration Option Register (200h)

Operation	D ₇	D ₆	D ₅	D ₄	D ₃	D ₂	D ₁	D ₀
Read/ Write	SRESET	LevIREQ	Configuration Index					
Default Value	0	0	0	0	0	0	0	0

Bit(s)	Description
SRESET	When set, this bit initiates a software-reset sequence, which is equivalent to a power-on reset or hardware reset.
LevIREQ	IREQ# interrupt signal level mode select: <ul style="list-style-type: none"> • Logic 0 = Pulse mode • Logic 1 = Level mode
Configuration Index	<ul style="list-style-type: none"> • Memory-mapped mode 000000B • Independent I/O mode 000001B • Primary mode 000010B • Secondary mode 000011B

SILICONSYSTEMS PROPRIETARY

This document and the information contained within it is confidential and proprietary to SiliconSystems, Inc. All unauthorized use and/or reproduction is prohibited.

CONFIGURATION AND STATUS REGISTER (202H)

The Configuration and Status Register (CSR) informs the host of any status changes with regard to power-down.

Table 23: Configuration and Status Register (202h)

Operation	D ₇	D ₆	D ₅	D ₄	D ₃	D ₂	D ₁	D ₀
Read	Changed	SigChg	IOis8	0	0	PwrDn	Int	0
Write	Changed	SigChg	IOis8	0	0	PwrDn	Int	0
Default Value	0	0	0	0	0	0	0	0

Bit(s)	Description
Changed	Indicates that either CREADY (D5) or CWPort (D4) of the Pin Replacement register is set. Additionally, this bit changes state as the Powerdown (D2) bit changes.
SigChg	Outputs the inverse state of the Changed bit to the hardware interface signal STSCHG# at the card interface.
Iois8	<p>Informs the host of the valid data bus width for the operations in progress:</p> <ul style="list-style-type: none"> • 0 = 16-bit data transfer • 1 = 8-bit data transfer
PwrDwn	Indicates the state of the Card, which is either operating -0 or powerdown mode 1. During powerdown mode, no commands are accepted. Additionally, the host may not initiate a powerdown request when the card is busy via the Status register or the Hardware RDY/BSY pin.
Int	Indicates the inverse of the IREQ# status signal.

SILICONSYSTEMS PROPRIETARY

This document and the information contained within it is confidential and proprietary to SiliconSystems, Inc. All unauthorized use and/or reproduction is prohibited.

PIN PLACEMENT REGISTER (204H)

Table 24: Pin Placement Register (204h)

Operation	D ₇	D ₆	D ₅	D ₄	D ₃	D ₂	D ₁	D ₀
Read/ Write	CBVD1	CBVD2	CRDY	CWProt	RBVD1	RBVD2	RRDY	RWProt
Default Value	0	0	0	0	1	1	0	0

Bit(s)	Description
CRDY	Indicates a bit change in the RRDY (D1) bit.
CWProt	Indicates a bit change in the RWProt (D0) bit.
RRDY	When set: <ul style="list-style-type: none"> • High 1 informs the host that the card is ready • Low 0 state indicates the card is busy
RWProt	Indicates Write Protect is enabled when set to 1, and disabled when 0.

SILICONSYSTEMS PROPRIETARY

This document and the information contained within it is confidential and proprietary to SiliconSystems, Inc.
All unauthorized use and/or reproduction is prohibited.

SOCKET AND COPY REGISTER (206H)

Table 25: Socket and Copy Register (206h)

Operation	D ₇	D ₆	D ₅	D ₄	D ₃	D ₂	D ₁	D ₀
Read/Write	RFU	Copy Number			Socket Number			
Default Value	0	0	0	0	0	0	0	0

Bit(s)	Description
RFU	Reserved for future use.
Copy Number	<p>Indicates the card number. Allows the host to differentiate between identical cards by writing to the bit of the card that is being accessed. This value is compared to the DRV bit in the ATA Drive/Head register.</p> <ul style="list-style-type: none"> • Card 0: 000B = (D6, D5, D4) (default) • Card 1: 001B = (D6, D5, D4) (alternate)
Socket Number	The host writes the socket number that identifies the inserted card.

SILICONSYSTEMS PROPRIETARY

This document and the information contained within it is confidential and proprietary to SiliconSystems, Inc.
All unauthorized use and/or reproduction is prohibited.

COMMON MEMORY DESCRIPTION AND OPERATION

Common memory space can be accessed when the SiliconDrive is configured in memory-mapped mode.

COMMON MEMORY READ OPERATIONS

Common memory read operations are issued by asserting CE1#, CE2#, or both, and OE# low, REG#, and WE# must be inactive.

Table 26: Common Memory Read Operations

Function Mode	REG#	CE1#	CE2#	A0	OE#	WE#	D[15:8]	D[7:0]
Standby	X	H	H	X	X	X	High-Z	High-Z
Byte Access	H	L	H	L	L	H	High-Z	Even
	H	L	H	H	L	H	High-Z	Odd
Word Access	H	L	L	X	L	H	Odd	Even
Odd Byte Only Access	H	H	L	X	L	H	Odd	High-Z

COMMON MEMORY WRITE OPERATIONS

Common memory write operations are issued by asserting CE1#, CE2#, or both, and WE# low, REG#, and OE# must be inactive.

Table 27: Common Memory Write Operations

Function Mode	REG#	CE1#	CE2#	A0	OE#	WE#	D[15:8]	D[7:0]
Standby	X	H	H	X	X	X	High-Z	High-Z
Byte Access	H	L	H	L	H	L	High-Z	Even
	H	L	H	H	H	L	High-Z	Odd
Word Access	H	L	L	X	H	L	Odd	Even
Odd Byte Only Access	H	H	L	X	H	L	Odd	High-Z

SILICONSYSTEMS PROPRIETARY

This document and the information contained within it is confidential and proprietary to SiliconSystems, Inc.
All unauthorized use and/or reproduction is prohibited.

I/O SPACE DESCRIPTION AND OPERATION**I/O SPACE READ OPERATIONS***Table 28: I/O Space Read Operations*

Function Mode	REG#	CE1#	CE2#	A0	IORD#	IOWR#	D[15:8]	D[7:0]
Standby	X	H	H	X	X	X	High-Z	High-Z
Byte Access	L	L	H	L	L	H	High-Z	Even
	L	L	H	H	L	H	High-Z	Odd
Word Access	L	L	L	L	L	H	Odd	Even
I/O Inhibit	H	X	X	X	L	H	High-Z	High-Z
Odd Byte Only Access	L	H	L	X	L	H	Odd	High-Z

I/O SPACE WRITE OPERATIONS*Table 29: I/O Space Write Operations*

Function Mode	REG#	CE1#	CE2#	A0	IORD#	IOWR#	D[15:8]	D[7:0]
Standby	X	H	H	X	X	X	X	X
Byte Access	L	L	H	L	H	L	X	Even
	L	L	H	H	H	L	X	Odd
Word Access	L	L	L	L	H	L	Odd	Even
I/O Inhibit	H	X	X	X	H	L	X	X
Odd Byte Only Access	L	H	L	X	H	L	Odd	X

SILICONSYSTEMS PROPRIETARY

This document and the information contained within it is confidential and proprietary to SiliconSystems, Inc.
All unauthorized use and/or reproduction is prohibited.

ATA AND TRUE IDE REGISTER DECODING

SiliconDrive can be configured as either a a memory-mapped or an an I/O devices. As noted earlier, communication to and from the drive is accomplished using the ATA Command Block.

MEMORY-MAPPED REGISTER DECODING

In memory-mapped mode, the SiliconDrive registers are accessed via standard memory references (i.e., OE# and WE#). The ATA registers are mapped to common memory space in a 2KB window starting at address 0.

Table 30: Memory-Mapped Register Decoding

Reg#	Offset	A10	A9:A4	A3	A2	A1	A0	OE# = L	WE# = L
1	0	0	X	0	0	0	0	Even Data Read	Even Data Write
1	1	0	X	0	0	0	1	Error	Feature
1	2	0	X	0	0	1	0	Sector Count	Sector Count
1	3	0	X	0	0	1	1	Sector Number	Sector Number
1	4	0	X	0	1	0	0	Cylinder Low	Cylinder Low
1	5	0	X	0	1	0	1	Cylinder High	Cylinder High
1	6	0	X	0	1	1	0	Drive/Head	Drive/Head
1	7	0	X	0	1	1	1	Status	Command
1	8	0	X	1	0	0	0	Duplicate Even Data Read	Duplicate Even Data Write
1	9	0	X	1	0	0	1	Duplicate Odd Data Read	Duplicate Odd Data Write
1	D	0	X	1	1	0	1	Duplicate Error	Duplicate Feature
1	E	0	X	1	1	1	0	Alternate Status	Device Control
1	F	0	X	1	1	1	1	Drive Address	Reserved
1	X	1	X	X	X	X	0	Even Data Read	Even Data Write
1	X	1	X	X	X	X	1	Odd Data Read	Odd Data Write

SILICONSYSTEMS PROPRIETARY

This document and the information contained within it is confidential and proprietary to SiliconSystems, Inc.
All unauthorized use and/or reproduction is prohibited.

INDEPENDENT I/O MODE REGISTER DECODING

Independent I/O mode or contiguous I/O mode requires the host to decode a continuous block of 16 I/O registers to select the SiliconDrive.

Table 31: Independent I/O Mode Register Decoding

Reg#	Offset	A10	A9:A4	A3	A2	A1	A0	OE# = L	WE# = L
0	0	X	X	0	0	0	0	Even Data Read	Even Data Write
0	1	X	X	0	0	0	1	Error	Feature
0	2	X	X	0	0	1	0	Sector Count	Sector Count
0	3	X	X	0	0	1	1	Sector Number	Sector Number
0	4	X	X	0	1	0	0	Cylinder Low	Cylinder Low
0	5	X	X	0	1	0	1	Cylinder High	Cylinder High
0	6	X	X	0	1	1	0	Drive/Head	Drive/Head
0	7	X	X	0	1	1	1	Status	Command
0	8	X	X	1	0	0	0	Duplicate Even Data Read	Duplicate Even Data Write
0	9	X	X	1	0	0	1	Duplicate Odd Data Read	Duplicate Odd Data Write
0	D	X	X	1	1	0	1	Duplicate Error	Duplicate Feature
0	E	X	X	1	1	1	0	Alternate Status	Device Control
0	F	X	X	1	1	1	1	Drive Address	Reserved

SILICONSYSTEMS PROPRIETARY

This document and the information contained within it is confidential and proprietary to SiliconSystems, Inc.
All unauthorized use and/or reproduction is prohibited.

PRIMARY AND SECONDARY I/O MAPPED REGISTER DECODING

Table 32: Primary and Secondary I/O Mapped Register Decoding

Reg#	A10	A9:A4 Primary	A9:A4 Secondary	A3	A2	A1	A0	IORD# = L	IOWR# = L
0	X	1F _{xh}	17 _{xh}	0	0	0	0	Even Data Read	Even Data Write
0	X	1F _{xh}	17 _{xh}	0	0	0	1	Error	Feature
0	X	1F _{xh}	17 _{xh}	0	0	1	0	Sector Count	Sector Count
0	X	1F _{xh}	17 _{xh}	0	0	1	1	Sector Number	Sector Number
0	X	1F _{xh}	17 _{xh}	0	1	0	0	Cylinder Low	Cylinder Low
0	X	1F _{xh}	17 _{xh}	0	1	0	1	Cylinder High	Cylinder High
0	X	1F _{xh}	17 _{xh}	0	1	1	0	Drive/Head	Drive/Head
0	X	1F _{xh}	17 _{xh}	0	1	1	1	Status	Command
0	X	3F _{xh}	37 _{xh}	0	1	1	0	Alternate Status	Device Control
0	X	3F _{xh}	37 _{xh}	0	1	1	1	Drive Address	Reserved

SILICONSYSTEMS PROPRIETARY

This document and the information contained within it is confidential and proprietary to SiliconSystems, Inc.
All unauthorized use and/or reproduction is prohibited.

TASK FILE REGISTER SPECIFICATION

The Task File registers are used for reading and writing the storage data in the SiliconDrive. The decoded addresses are as shown in the following table.

Table 33: Task File Register Specification

CS0#	CS1#	DA02	DA01	DA00	DIOR# = L	DIOW# = L
0	1	0	0	0	Data	Data
0	1	0	0	1	Error	Feature
0	1	0	1	0	Sector Count	Sector Count
0	1	0	1	1	Sector Number	Sector Number
0	1	1	0	0	Cylinder Low	Cylinder Low
0	1	1	0	1	Cylinder High	Cylinder High
0	1	1	1	0	Drive/Head	Drive/Head
0	1	1	1	1	Status	Command
0	0	X	X	X	Invalid	Invalid
1	1	X	X	X	High-Z	Not Used
1	0	0	X	X	High-Z	Not Used
1	0	1	0	X	High-Z	Not Used
1	0	1	1	0	Alternate Status	Device Control
1	0	1	1	1	Device Address	Not Used

SILICONSYSTEMS PROPRIETARY

This document and the information contained within it is confidential and proprietary to SiliconSystems, Inc.
All unauthorized use and/or reproduction is prohibited.

ATA REGISTERS

DATA REGISTER

The Data register is a 16-bit register used to transfer data blocks between the host and drive buffers. The register may set to 8-bit mode by using the Set Features Command defined in "[Seek — 7Xh](#)" on page 78.

ERROR REGISTER

The Error register contains the error status, if any, generated from the last executed ATA command. The contents are qualified by the ERR bit being set in "[Status Register](#)" on page 54.

Table 34: Error Register

Operation	D ₇	D ₆	D ₅	D ₄	D ₃	D ₂	D ₁	D ₀
Read	BBK	UNC	MC	IDNF	MCR	ABRT	TKNOF	AMNF
Default Value	0	0	0	0	0	0	0	0

Bit(s)	Description
7	Bad Block Detected (BBK). Set when a bad block is detected.
6	Uncorrectable Data Error (UNC). Set when an uncorrectable error is encountered.
5	Media Changed (MC). Set to 0.
4	ID Not Found (IDNF). Set when the sector ID is not found.
3	MCR (Media Change Request). Set to 0.
2	Aborted Command (ABRT). Set when a command is aborted due to a drive error.
1	Track 0 Not Found (TKONF). Set when the execute drive diagnostic command is executed.
0	Address Mark Not Found (AMNF). Set in the case of a general error.

SILICONSYSTEMS PROPRIETARY

This document and the information contained within it is confidential and proprietary to SiliconSystems, Inc.
All unauthorized use and/or reproduction is prohibited.

FEATURE REGISTER

The Feature register is command-specific and used to enable and disable interface features. This register supports only either odd or even byte data transfers.

Table 35: Feature Register

Operation	D ₇	D ₆	D ₅	D ₄	D ₃	D ₂	D ₁	D ₀
Read/Write	Feature Byte							

SILICONSYSTEMS PROPRIETARY

This document and the information contained within it is confidential and proprietary to SiliconSystems, Inc.
All unauthorized use and/or reproduction is prohibited.

SECTOR COUNT REGISTER

The Sector Count register is used to read or write the sector count of the data for which an ATA transfer has been made.

Table 36: Sector Count Register

Operation	D ₇	D ₆	D ₅	D ₄	D ₃	D ₂	D ₁	D ₀
Read/Write	Sector Count							
Default Value	0	0	0	0	0	0	0	1

SILICONSYSTEMS PROPRIETARY

This document and the information contained within it is confidential and proprietary to SiliconSystems, Inc.
All unauthorized use and/or reproduction is prohibited.

SECTOR NUMBER REGISTER

The Sector Number register is set by the host to specify the starting sector number associated with the next ATA command to be executed. Following a qualified ATA command sequence, the device sets the register value to the last sector read or written as a result of the previous AT command.

When Logical Block Addressing (LBA) mode is implemented and the host issues a command, the contents of the register describe the Logical Block Number bits A[7:0]. Following an ATA command, the device loads the register with the LBA block number resulting from the last ATA command.

Table 37: Sector Number Register

Operation	D ₇	D ₆	D ₅	D ₄	D ₃	D ₂	D ₁	D ₀
Read/Write	Sector Number (CHS Addressing)							
	Logical Block Number bits A07-A00 (LBA Addressing)							
Default Value	0	0	0	0	0	0	0	1

SILICONSYSTEMS PROPRIETARY

This document and the information contained within it is confidential and proprietary to SiliconSystems, Inc.
All unauthorized use and/or reproduction is prohibited.

CYLINDER LOW REGISTER

The Cylinder Low register is set by the host to specify the cylinder number low byte. Following an ATA command, the content of the register is written by the device, identifying the cylinder number low byte.

In LBA mode, the 8-bit register maintains the contents of the Logical Block number address bits A15:A08.

Table 38: Cylinder Low Register

Operation	D ₇	D ₆	D ₅	D ₄	D ₃	D ₂	D ₁	D ₀
Read/Write	Cylinder Number Low Byte (CHS Addressing)							
	Logical Block Number bits A15-A08 (LBA Addressing)							
Default Value	0	0	0	0	0	0	0	0

SILICONSYSTEMS PROPRIETARY

This document and the information contained within it is confidential and proprietary to SiliconSystems, Inc.
All unauthorized use and/or reproduction is prohibited.

CYLINDER HIGH REGISTER

The Cylinder High register is set by the host to specify the cylinder number high byte. Following an ATA command, the content of the register is set internally by the device, identifying the cylinder number high byte.

In LBA mode, the 8-bit register maintains the contents of the Logical Block number address bits A23:A16.

Table 39: Cylinder High Register

Operation	D ₇	D ₆	D ₅	D ₄	D ₃	D ₂	D ₁	D ₀
Read/Write	Cylinder Number Low Byte (CHS Addressing)							
	Logical Block Number bits A23-A16 (LBA Addressing)							
Default Value	0	0	0	0	0	0	0	0

SILICONSYSTEMS PROPRIETARY

This document and the information contained within it is confidential and proprietary to SiliconSystems, Inc.
All unauthorized use and/or reproduction is prohibited.

DRIVE/HEAD REGISTER

The Drive/Head register is used by the host and the device to select the type of addressing (CHS or LBA), the drive letter, and either bits 3-0 of the head number in CHS mode or logical block number bits 27-24 in LBA mode.

Table 40: Drive/Head Register

Operation	D ₇	D ₆	D ₅	D ₄	D ₃	D ₂	D ₁	D ₀
Read/Write	1	LBA	1	DRV	HS3 LBA27	HS2 LBA26	HS1 LBA25	HS0 LBA24
Default Value	1	0	1	0	0	0	0	0

The Drive/Head register is used by the host to specify one of a pair of ATA drives present in the platform.

Bit(s)	Description
6	LBA. Selects between CHS (0) and LBA (1) addressing mode.
4	Drive Address (DRV). Indicates the drive number selected by the host, either 0 or 1.
3-0	<p>HS3 to 0. Indicates bits 3-0 of the head number in CHS addressing mode or LBA bits 27-24 in LBA mode.</p> <ul style="list-style-type: none"> • CHS to LBA conversion: $LBA = (C \times HpC + H) \times SpH + S - 1$ • LBA to CHS conversion: <ul style="list-style-type: none"> ◦ $C = LBA / (HpC \times SpH)$ ◦ $H = (LBA / SpH) \bmod (HpC)$ ◦ $S = (LBA \bmod (SpH)) + 1$ <p>...where:</p> <ul style="list-style-type: none"> ◦ C is the cylinder number ◦ H is the head number ◦ S is the sector count ◦ HpC is the head count per cylinder count ◦ SpH is the sector count per head count (track)

SILICONSYSTEMS PROPRIETARY

This document and the information contained within it is confidential and proprietary to SiliconSystems, Inc.
All unauthorized use and/or reproduction is prohibited.

STATUS REGISTER

The Status register provides the device's current status to the host. The status register is an 8-bit read-only register. When the contents of the register are read by the host, the IREQ# bit is cleared.

Table 41: Status Register

Operation	D ₇	D ₆	D ₅	D ₄	D ₃	D ₂	D ₁	D ₀
Read/Write	BSY	DRDY	DWF	DSC	DRQ	CORR	IDX	ERR
Default Value	0	0	0	0	0	0	0	0

Bit(s)	Description
7	Busy (BSY). Set when the drive is busy and unable to process any new ATA commands.
6	Data Ready (DRDY). Set when the device is ready to accept ATA commands from the host.
5	Drive Write Fault (DWF). Always set to 0.
4	Drive Seek Complete (DSC). Set when the drive heads have been positioned over a specific track.
3	Data Request (DRQ). Set when a device is ready to transfer a word or byte of data to or from the host and the device.
2	Corrected Data (CORR). Always set to 0.
1	Index (IDX). Always set to 0.
0	Error (ERR). Set when an error occurs during the previous ATA command.

SILICONSYSTEMS PROPRIETARY

This document and the information contained within it is confidential and proprietary to SiliconSystems, Inc.
All unauthorized use and/or reproduction is prohibited.

COMMAND REGISTER

The Command register specifies the ATA command code being issued to the drive by the host. Execution of the command begins immediately following the issuance of the command register code by the host.

Table 42: Command Register

Operation	D ₇	D ₆	D ₅	D ₄	D ₃	D ₂	D ₁	D ₀
Read/Write	ATA Command Code							

See ["ATA Command Block and Set Description" on page 59](#) for a listing of the supported ATA commands.

SILICONSYSTEMS PROPRIETARY

This document and the information contained within it is confidential and proprietary to SiliconSystems, Inc.
All unauthorized use and/or reproduction is prohibited.

ALTERNATE STATUS REGISTER

The Alternate Status register is a read-only register indicating the status of the device, following the previous ATA command. See ["Status Register" on page 54](#) for specific details.

Table 43: Alternate Status Register

Operation	D ₇	D ₆	D ₅	D ₄	D ₃	D ₂	D ₁	D ₀
Read/Write	BSY	DRDY	DWF	DSC	DRQ	CORR	IDX	ERR
Default Value	0	0	0	0	0	0	0	0

SILICONSYSTEMS PROPRIETARY

This document and the information contained within it is confidential and proprietary to SiliconSystems, Inc.
All unauthorized use and/or reproduction is prohibited.

DEVICE CONTROL REGISTER

The Device Control register is used to control the interrupt request and issue ATA software resets.

Table 44: Device Control Register

Operation	D ₇	D ₆	D ₅	D ₄	D ₃	D ₂	D ₁	D ₀
Write	-	-	-	-	1	SRST	nIEN	0

Bit(s)	Description
7-4	Reserved bits.
3	Always set to 1.
2	Software Reset (SRST) . When set, resets the ATA software.
1	Interrupt Enable (nIEN) . When set, device interrupts are disabled. There is no function in the memory-mapped mode.
0	Always set to 0.

SILICONSYSTEMS PROPRIETARY

This document and the information contained within it is confidential and proprietary to SiliconSystems, Inc.
All unauthorized use and/or reproduction is prohibited.

DEVICE ADDRESS REGISTER

The Device Address register is used to maintain compatibility with ATA disk drive interfaces.

Table 45: Device Address Register

Operation	D ₇	D ₆	D ₅	D ₄	D ₃	D ₂	D ₁	D ₀
Read/Write	-	nWTG	nHS3	nHS2	nHS1	nHS0	nDS1	nDS0
Default Value	0	0	1	1	1	1	1	0

Bit(s)	Description
7	Reserved bit.
6	Write Gate (nWTG) . Low when a write to the device is in process.
5-2	nHS3 to nHS0 . The negated binary address of the currently selected head.
1	nDS1 . Low when drive 1 is selected and active.
0	nDS0 . Low when drive 0 is selected and active.

SILICONSYSTEMS PROPRIETARY

This document and the information contained within it is confidential and proprietary to SiliconSystems, Inc.
All unauthorized use and/or reproduction is prohibited.

ATA COMMAND BLOCK AND SET DESCRIPTION

In accordance with the *ANSI ATA Specification*, the device implements seven registers that are used to transfer instructions to the device by the host. These commands follow the ANSI standard ATA protocol. A description of the ATA command block is provided in the following table.

Table 46: ATA Command Block and Set Description

Operation	D ₇	D ₆	D ₅	D ₄	D ₃	D ₂	D ₁	D ₀
Feature					X			
Sector Count					X			
Sector Number					X			
Cylinder Low					X			
Cylinder High					X			
Drive Head	1	LBA	1	Drive			X	
Command					X			

ATA COMMAND SET

Table 47: ATA Command Set

Class	Command Name	Command Code	Registers Used					
			FR	SC	SN	CY	DH	LBA
1	Check Power Mode	98h, E5h	-	-	-	-	D	-
1	Execute Drive Diagnostics	90h	-	-	-	-	D	-
1	Erase Sector	C0h	-	Y	Y	Y	Y	Y
2	Format Track	50h	-	Y	-	Y	Y	Y
1	Identify Drive	ECh	-	-	-	-	D	-
1	Idle	97h, E3h	-	Y	-	-	D	-
1	Idle Immediate	95h, E1h	-		-	-	D	-
1	Initialize Drive Parameters	91h	-	Y	-	-	Y	-
1	Read Buffer	E4h	-	-	-	-	D	-
1	Read DMA*	C8h	-	Y	Y	Y	Y	Y
1	Read Multiple	C4h	-	Y	Y	Y	Y	Y

SILICONSYSTEMS PROPRIETARY

This document and the information contained within it is confidential and proprietary to SiliconSystems, Inc. All unauthorized use and/or reproduction is prohibited.

Table 47: ATA Command Set (Continued)

Class	Command Name	Command Code	Registers Used					
			FR	SC	SN	CY	DH	LBA
1	Read Long Sector	22h, 23h	-	-	Y	Y	Y	Y
1	Read Sector(s)	20h, 21h	-	-	Y	Y	Y	Y
1	Read Verify Sector(s)	40h, 41h	-	Y	Y	Y	Y	Y
1	Recalibrate	1Xh	-	-	-	-	Y	-
1	Request Sense	03h	-	-	-	-	D	-
1	Seek	7Xh	-	-	Y	Y	Y	Y
1	Set Features	EFh	Y	-	-	-	D	-
1	Set Multiple Mode	C6h	-	Y	-	-	D	-
1	Set Sleep Mode	99h, E6h	-	-	-	-	D	-
1	Standby	96h, E2h	-	-	-	-	D	-
1	Standby Immediate	94h, E0h	-	-	-	-	D	-
1	Translate Sector	87h	-	Y	Y	Y	Y	Y
1	Wear Level	F5h	-	-	-	-	Y	-
2	Write Buffer	E8h	-	-	-	-	D	-
1	Write DMA*	CAh	-	Y	Y	Y	Y	Y
2	Write Long Sector	32h, 33h	-	-	Y	Y	Y	Y
3	Write Multiple	C5h	-	Y	Y	Y	Y	Y
3	Write Multiple w/o Erase	CDh	-	Y	Y	Y	Y	Y
2	Write Sector(s)	30h, 31h	-	Y	Y	Y	Y	Y
2	Write Sector(s) w/o Erase	38h	-	Y	Y	Y	Y	Y
3	Write Verify	3Ch	-	Y	Y	Y	Y	Y

* = This function does not apply to SiliconDrives that have DMA disabled.

Notes:

- CY = Cylinder
- SC = Sector Count
- DH = Drive/Head
- SN = Sector Number
- FR = Feature LBA — LBA bit of the Drive/Head register (D denotes that only the drive bit is used)

SILICONSYSTEMS PROPRIETARY

This document and the information contained within it is confidential and proprietary to SiliconSystems, Inc.
All unauthorized use and/or reproduction is prohibited.

Check Power Mode — 98h, E5h

The Check Power Mode command verifies the device's current power mode. When the device is configured for standby mode or is entering or exiting standby, the BSY bit is set, the Sector Count register set to 00h, and the BSY bit is cleared. In idle mode, BSY is set and the Sector Count register is set to FFh. The BSY bit is then cleared and an interrupt is issued.

Table 48: Check Power Mode — 98h, E5h

Register	D ₇	D ₆	D ₅	D ₄	D ₃	D ₂	D ₁	D ₀
Feature					X			
Sector Count					X			
Sector Number					X			
Cylinder Low					X			
Cylinder High					X			
Drive Head	X	X	X	Drive				
Command								98h or E5h

SILICONSYSTEMS PROPRIETARY

This document and the information contained within it is confidential and proprietary to SiliconSystems, Inc.
All unauthorized use and/or reproduction is prohibited.

Executive Drive Diagnostic — 90h

The Executive Drive Diagnostic performs an internal read write diagnostic test using (AA55h and 55AAh). If an error is detected in the read/write buffer, the Error register reports the appropriate diagnostic code.

Table 49: Executive Drive Diagnostic — 90h

Register	D ₇	D ₆	D ₅	D ₄	D ₃	D ₂	D ₁	D ₀
Feature					X			
Sector Count					X			
Sector Number					X			
Cylinder Low					X			
Cylinder High					X			
Drive Head	X	X	X					Drive
Command								90h

SILICONSYSTEMS PROPRIETARY

This document and the information contained within it is confidential and proprietary to SiliconSystems, Inc.
All unauthorized use and/or reproduction is prohibited.

Format Track — 50h

The Format Track command formats the common solid-state memory array.

Table 50: Format Track — 50h

Register	D ₇	D ₆	D ₅	D ₄	D ₃	D ₂	D ₁	D ₀
Feature	X							
Sector Count	Sector Count							
Sector Number	Sector Number (LBA7-0)							
Cylinder Low	Cylinder Low (LBA15-8)							
Cylinder High	Cylinder High (LBA23-16)							
Drive Head	1	LBA	1	Drive	Head Number (LBA27-24)			
Command	50h							

SILICONSYSTEMS PROPRIETARY

This document and the information contained within it is confidential and proprietary to SiliconSystems, Inc.
All unauthorized use and/or reproduction is prohibited.

Identify Drive — ECh

Issued by the host, the Identify Drive command provides 256 bytes of drive attribute data (i.e., sector size, count, and so on) The identify drive data structure is detailed in the following table.

Table 51: Identify Drive — ECh

Register	D ₇	D ₆	D ₅	D ₄	D ₃	D ₂	D ₁	D ₀
Feature					X			
Sector Count					X			
Sector Number					X			
Cylinder Low					X			
Cylinder High					X			
Drive Head	X	X	X	Drive			X	
Command					ECh			

SILICONSYSTEMS PROPRIETARY

This document and the information contained within it is confidential and proprietary to SiliconSystems, Inc.
All unauthorized use and/or reproduction is prohibited.

*Identify Drive — Drive Attribute Data***Table 52: Identify Drive — Drive Attribute Data**

Word Address	Data Default	Bytes	Data Description
0	044Ah (fixed ID bit) in IDE mode 848A (removable ID bit) in PCMCIA memory and I/O modes	2	General configuration bit information <ul style="list-style-type: none"> • 15: Non-magnetic disk • 14: Formatting speed latency permissible gap needed • 13: Track Offset option supported • 12: Data Strobe Offset option supported • 11: Over 0.5% rotational speed difference • 10: Disk transfer rate >10Mbps • 9: 10Mbps >= disk transfer rate >5Mbps • 8: 5Mbps >= disk transfer rate • 7: Removable cartridge drive • 6: Fixed drive • 5: Spindle Motor Control option executed • 4: Over 15μs changing head time • 3: Non-MFM encoding • 2: Soft sector allocation • 1: Hard sector allocation • 0: Reserved
1	XXXXh	2	Number of cylinders
2	0000h	2	Reserved
3	00XXh	2	Number of heads
4	0000h	2	Number of unformatted bytes per track
5	XXXXh	2	Number of unformatted bytes per sector
6	XXXXh	2	Number of sectors per track
7-8	XXXXh	4	Number of sectors per device
9	0000h	2	Reserved
10-19	XXXXh	20	Serial number

SILICONSYSTEMS PROPRIETARY

This document and the information contained within it is confidential and proprietary to SiliconSystems, Inc.
All unauthorized use and/or reproduction is prohibited.

Table 52: Identify Drive — Drive Attribute Data (Continued)

Word Address	Data Default	Bytes	Data Description
20	0002h	2	Buffer type <ul style="list-style-type: none"> • 0000h: Not specified • 0001h: A single-ported, single-sector buffer • 0002h: A dual-ported multisection buffer • 0003h: A dual-ported multisection buffer with a read caching
21	0002h	2	Buffer size in 512-byte increments
22	0004h	2	Number of ECC bytes passed on read/write long commands
23-26	XXXXh	8	Firmware revision (eight ASCII characters)
27-46	XXXXh	40	Model number (40 ASCII characters)
47	0001h	2	7-0: Maximum number of sectors that can be transferred with a Read/Write Multiple command per interrupt
48	0000h	2	Double word (32 bit) not supported
49	0002h	2	<ul style="list-style-type: none"> • 11: IORDY supported • 9: LBA supported • 8: DMA supported
50	0000h	2	Reserved
51	0100h	2	15-8: PIO data transfer cycle timing
52	0000h	2	15-8: DMA data transfer cycle timing
53	0000h	2	<ul style="list-style-type: none"> • 1: Words 64-70 are valid • 0: Words 54-58 are valid
54	XXXXh	2	Current number of cylinders
55	XXXXh	2	Current number of heads
56	XXXXh	2	Current sectors per track
57-58	XXXXh	4	Current capacity in sectors
59	010Xh	2	7-0: Current sectors can be transferred with a Read/Write Multiple command per interrupt
60-61	XXXXh	4	Total number of sectors addressable in LBA mode
62	0000h	2	Single-word DMA modes supported

SILICONSYSTEMS PROPRIETARY

This document and the information contained within it is confidential and proprietary to SiliconSystems, Inc.
All unauthorized use and/or reproduction is prohibited.

Table 52: Identify Drive — Drive Attribute Data (Continued)

Word Address	Data Default	Bytes	Data Description
63	0407h	2	Multiword DMA modes supported
64	0003h	2	PIO modes supported
65	0078h	2	Minimum DMA transfer cycle time per word (ns)
66	0078h	2	Manufacturer's recommended DMA transfer cycle time (ns)
67	0078h	2	Minimum PIO transfer cycle time without flow control (ns)
68	0078h	2	Minimum PIO transfer cycle time with IORDY flow controls (ns)
69-127	0000h	118	Reserved
128-159	0000h	64	Vendor-unique
160-255	0000h	192	Reserved

SILICONSYSTEMS PROPRIETARY

This document and the information contained within it is confidential and proprietary to SiliconSystems, Inc.
All unauthorized use and/or reproduction is prohibited.

Idle — 97h, E3h

When issued by the host, the device's internal controller sets the BSY bit, enters the Idle mode, clears the BSY bit, and generates an interrupt. If the sector count is non-zero, it is interpreted as a timer count with each count being 5ms, and the automatic power-down mode is enabled. If the sector count is zero, the automatic power-down mode is disabled.

Table 53: Idle — 97h, E3h

Register	D ₇	D ₆	D ₅	D ₄	D ₃	D ₂	D ₁	D ₀
Feature	X							
Sector Count	Timer Count (5ms increments)							
Sector Number	X							
Cylinder Low	X							
Cylinder High	X							
Drive Head	X	X	X	Drive	X			
Command	97h or E3h							

SILICONSYSTEMS PROPRIETARY

This document and the information contained within it is confidential and proprietary to SiliconSystems, Inc.
All unauthorized use and/or reproduction is prohibited.

Idle Immediate — 95h, E1h

When issued by the host, the device's internal controller sets the BSY bit, enters Idle Mode, clears the BSY bit, and issues an interrupt. The interrupt is issued whether or not the Idle mode is fully entered.

Table 54: Idle Immediate — 95h, E1h

Register	D ₇	D ₆	D ₅	D ₄	D ₃	D ₂	D ₁	D ₀
Feature					X			
Sector Count					X			
Sector Number					X			
Cylinder Low					X			
Cylinder High					X			
Drive Head	X	X	X	Drive			X	
Command	95h or E1h							

SILICONSYSTEMS PROPRIETARY

This document and the information contained within it is confidential and proprietary to SiliconSystems, Inc.
All unauthorized use and/or reproduction is prohibited.

Initialize Drive Parameters — 91h

Initialize Drive Parameters allows the host to set the sector counts per track and the head counts per cylinder to 1 Fixed. Upon issuance of the command, the device sets the BSY bit and associated parameters, clears the BSY bit, and issues an interrupt.

Table 55: Initialize Drive Parameters — 91h

Register	D ₇	D ₆	D ₅	D ₄	D ₃	D ₂	D ₁	D ₀
Feature	X							
Sector Count	Sector Count (Number of Sectors)							
Sector Number	X							
Cylinder Low	X							
Cylinder High	X							
Drive Head	X	0	X	Drive	Head Number (Number of Heads — 1)			
Command	91h							

SILICONSYSTEMS PROPRIETARY

This document and the information contained within it is confidential and proprietary to SiliconSystems, Inc.
All unauthorized use and/or reproduction is prohibited.

Recalibrate — 1Xh

The Recalibrate command sets the cylinder low and high, head number to 0h, and sector number to 1h in CHS mode. In LBA mode (i.e., LBA = 1), the sector number is set to 0h.

Table 56: Recalibrate — 1Xh

Register	D ₇	D ₆	D ₅	D ₄	D ₃	D ₂	D ₁	D ₀
Feature					X			
Sector Count					X			
Sector Number					X			
Cylinder Low					X			
Cylinder High					X			
Drive Head	1	LBA	1	Drive			X	
Command								1Xh

SILICONSYSTEMS PROPRIETARY

This document and the information contained within it is confidential and proprietary to SiliconSystems, Inc.
All unauthorized use and/or reproduction is prohibited.

Read Buffer — E4h

The Read Buffer command allows the host to read the contents of the sector buffer. When issued, the device sets the BSY bit and sets up the sector buffer data in preparation for the read operation. When the data is ready, the DRQ bit is set and the BSY bit in the Status register are set and cleared, respectively.

Table 57: Read Buffer — E4h

Register	D ₇	D ₆	D ₅	D ₄	D ₃	D ₂	D ₁	D ₀
Feature					X			
Sector Count					X			
Sector Number					X			
Cylinder Low					X			
Cylinder High					X			
Drive Head	X	X	X	Drive			X	
Command					E4h			

SILICONSYSTEMS PROPRIETARY

This document and the information contained within it is confidential and proprietary to SiliconSystems, Inc.
All unauthorized use and/or reproduction is prohibited.

Read DMA — C8h

The Read DMA command allows the host to read data using the DMA transfer protocol.

Note: This function does not apply to SiliconDrives that have DMA disabled.

Table 58: Read DMA — C8h

Register	D ₇	D ₆	D ₅	D ₄	D ₃	D ₂	D ₁	D ₀
Feature	X							
Sector Count	Sector Count							
Sector Number	Sector Number (LBA7-0)							
Cylinder Low	Cylinder Low (LBA15-8)							
Cylinder High	Cylinder High (LBA23-16)							
Drive Head	1	LBA	1	Drive	Head Number (LBA27-24)			
Command	C8h							

SILICONSYSTEMS PROPRIETARY

This document and the information contained within it is confidential and proprietary to SiliconSystems, Inc.
All unauthorized use and/or reproduction is prohibited.

Read Multiple — C4h

The Read Multiple command executes similarly to the Read Sector command, with the exception that interrupts are issued only when a block containing the counts of sectors defined by the Set Multiple command is transferred.

Table 59: Read Multiple — C4h

Register	D ₇	D ₆	D ₅	D ₄	D ₃	D ₂	D ₁	D ₀
Feature	X							
Sector Count	Sector Count							
Sector Number	Sector Number (LBA7-0)							
Cylinder Low	Cylinder Low (LBA15-8)							
Cylinder High	Cylinder High (LBA23-16)							
Drive Head	1	LBA	1	Drive	Head Number (LBA27-24)			
Command	C4h							

SILICONSYSTEMS PROPRIETARY

This document and the information contained within it is confidential and proprietary to SiliconSystems, Inc.
All unauthorized use and/or reproduction is prohibited.

Read Sector — 20h, 21h

The Read Sector command allows the host to read sectors 1 to 256 as specified in the Sector Count register. If the sector count is set to 0h, all 256 sectors of data are made available. When the command code is issued and the first sector of data has been transferred to the buffer, the DRQ bit is set. The Read Sector command is terminated by writing the cylinder, head, and sector number of the last sector read in the task file. On error, the read operation is aborted in the errant sector.

Table 60: Read Sector — 20h, 21h

Register	D ₇	D ₆	D ₅	D ₄	D ₃	D ₂	D ₁	D ₀
Feature	X							
Sector Count	Sector Count							
Sector Number	Sector Number (LBA7-0)							
Cylinder Low	Cylinder Low (LBA15-8)							
Cylinder High	Cylinder High (LBA23-16)							
Drive Head	1	LBA	1	Drive	Head Number (LBA27-24)			
Command	20h or 21h							

SILICONSYSTEMS PROPRIETARY

This document and the information contained within it is confidential and proprietary to SiliconSystems, Inc.
All unauthorized use and/or reproduction is prohibited.

Read Long Sector(s) — 22h, 23h

The Read Long Sector(s) command operates similarly to the Read Sector(s) command, with the exception that it transfers requested data sectors and ECC data. The long instruction ECC byte transfer for Long commands is a byte transfer at a fixed length of 4 bytes.

Table 61: Read Long Sector(s) — 22h, 23h

Register	D ₇	D ₆	D ₅	D ₄	D ₃	D ₂	D ₁	D ₀
Feature	X							
Sector Count	X							
Sector Number	Sector Number (LBA7-0)							
Cylinder Low	Cylinder Low (LBA15-8)							
Cylinder High	Cylinder High (LBA23-16)							
Drive Head	1	LBA	1	Drive	Head Number (LBA27-24)			
Command	22h or 23h							

SILICONSYSTEMS PROPRIETARY

This document and the information contained within it is confidential and proprietary to SiliconSystems, Inc.
All unauthorized use and/or reproduction is prohibited.

Read Verify Sector(s) — 40h, 41h

The Read Verify Sector(s) command operates similarly to the Read Sector(s) command, with the exception that it does not set the DRQ bit and does not transfer data to the host. When the requested sectors are verified, the onboard controller clears the BSY bit and issues an interrupt.

Table 62: Read Verify Sector(s) — 40h, 41h

Register	D ₇	D ₆	D ₅	D ₄	D ₃	D ₂	D ₁	D ₀
Feature	X							
Sector Count	Sector Count							
Sector Number	Sector Number (LBA7-0)							
Cylinder Low	Cylinder Low (LBA15-8)							
Cylinder High	Cylinder High (LBA23-16)							
Drive Head	1	LBA	1	Drive	Head Number (LBA27-24)			
Command	40h or 41h							

SILICONSYSTEMS PROPRIETARY

This document and the information contained within it is confidential and proprietary to SiliconSystems, Inc.
All unauthorized use and/or reproduction is prohibited.

Seek — 7Xh

The Seek command seeks and picks up the head to the tracks specified in the task file. When the command is issued, the solid-state memory chips do not need to be formatted. After an appropriate amount of time, the DSC bit is set.

Table 63: Seek — 7Xh

Register	D ₇	D ₆	D ₅	D ₄	D ₃	D ₂	D ₁	D ₀
Feature	X							
Sector Count	X							
Sector Number	Sector Number (LBA7-0)							
Cylinder Low	Cylinder Low (LBA15-8)							
Cylinder High	Cylinder High (LBA23-16)							
Drive Head	1	LBA	1	Drive	Head Number (LBA27-24)			
Command	7Xh							

SILICONSYSTEMS PROPRIETARY

This document and the information contained within it is confidential and proprietary to SiliconSystems, Inc.
All unauthorized use and/or reproduction is prohibited.

Set Features — EFh

The Set Features command allows the host to configure the feature set of the device according to the attributes listed in [Table 65](#).

Table 64: Set Features — EFh

Register	D ₇	D ₆	D ₅	D ₄	D ₃	D ₂	D ₁	D ₀
Feature	Feature							
Sector Count	X							
Sector Number	X							
Cylinder Low	X							
Cylinder High	X							
Drive Head	X	X	X	Drive	X			
Command	EFh							

Table 65: Set Features' Attributes

Feature	Operation
01h	Enable 8-bit data transfer
66h	Disable reverting to power on defaults
81h	Disable 8-bit data transfer
BBh	4 bytes of data apply on Read/Write Long commands
CCh	Enable revert to power on defaults

On power-up or following a hardware reset, the device is set to the default mode 81h.

SILICONSYSTEMS PROPRIETARY

This document and the information contained within it is confidential and proprietary to SiliconSystems, Inc.
All unauthorized use and/or reproduction is prohibited.

Set Multiple Mode — C6h

The Set Multiple Mode command allows the host to access the drive via Read Multiple and Write Multiple ATA commands. Additionally, the command sets the block count (i.e., the number of sectors within the block) for the Read/Write Multiple command. The sector count per block is set in the Sector Count register.

Table 66: Set Multiple Mode — C6h

Register	D ₇	D ₆	D ₅	D ₄	D ₃	D ₂	D ₁	D ₀
Feature	X							
Sector Count	Sector Count							
Sector Number	X							
Cylinder Low	X							
Cylinder High	X							
Drive Head	X	X	X	Drive	X			
Command	C6h							

SILICONSYSTEMS PROPRIETARY

This document and the information contained within it is confidential and proprietary to SiliconSystems, Inc.
All unauthorized use and/or reproduction is prohibited.

Set Sleep Mode — 99h, E6h

The Set Sleep Mode command allows the host to set the device in sleep mode. When the onboard controller transitions to sleep mode, it clears the BSY bit and issues an interrupt. The device interface then becomes inactive. Sleep mode can be exited by issuing either a hardware or software reset.

Table 67: Set Sleep Mode — 99h, E6h

Register	D ₇	D ₆	D ₅	D ₄	D ₃	D ₂	D ₁	D ₀
Feature					X			
Sector Count					X			
Sector Number					X			
Cylinder Low					X			
Cylinder High					X			
Drive Head	X	X	X	Drive			X	
Command								99h or E6h

SILICONSYSTEMS PROPRIETARY

This document and the information contained within it is confidential and proprietary to SiliconSystems, Inc.
All unauthorized use and/or reproduction is prohibited.

Standby — 96h, E2h

When the Standby command is issued by the host, it transitions the device into standby mode. If the Sector Count register is set to a value other than 0h, the Auto Powerdown function is enabled and the device returns to Idle mode.

Table 68: Standby — 96h, E2h

Register	D ₇	D ₆	D ₅	D ₄	D ₃	D ₂	D ₁	D ₀
Feature	X							
Sector Count	Timer Count (5ms x Timer Count)							
Sector Number	X							
Cylinder Low	X							
Cylinder High	X							
Drive Head	X	X	X	Drive	X			
Command	96h or E2h							

SILICONSYSTEMS PROPRIETARY

This document and the information contained within it is confidential and proprietary to SiliconSystems, Inc.
All unauthorized use and/or reproduction is prohibited.

Standby Immediate — 94h, E0h

When the Standby Immediate command is issued by the host, it transitions the device into standby mode.

Table 69: Standby Immediate — 94h, E0h

Register	D ₇	D ₆	D ₅	D ₄	D ₃	D ₂	D ₁	D ₀
Feature					X			
Sector Count					X			
Sector Number					X			
Cylinder Low					X			
Cylinder High					X			
Drive Head	X	X	X	Drive			X	
Command	94h or E0h							

SILICONSYSTEMS PROPRIETARY

This document and the information contained within it is confidential and proprietary to SiliconSystems, Inc.
All unauthorized use and/or reproduction is prohibited.

Write Buffer — E8h

The Write Buffer command allows the host to rewrite the contents of the 512- byte data buffer with the wanted data.

Table 70: Write Buffer — E8h

Register	D ₇	D ₆	D ₅	D ₄	D ₃	D ₂	D ₁	D ₀
Feature					X			
Sector Count					X			
Sector Number					X			
Cylinder Low					X			
Cylinder High					X			
Drive Head	X	X	X	Drive			X	
Command	E8h							

SILICONSYSTEMS PROPRIETARY

This document and the information contained within it is confidential and proprietary to SiliconSystems, Inc.
All unauthorized use and/or reproduction is prohibited.

Write DMA — CAh

The Write DMA command allows the host to write data using the DMA transfer protocol.

Note: This function does not apply to SiliconDrives that have DMA disabled.

Table 71: Write DMA — CAh

Register	D ₇	D ₆	D ₅	D ₄	D ₃	D ₂	D ₁	D ₀
Feature	X							
Sector Count	Sector Count							
Sector Number	Sector Number (LBA7-0)							
Cylinder Low	Cylinder Low(LBA15-8)							
Cylinder High	Cylinder High(LBA23-16)							
Drive Head	X	LBA	X	Drive	Head Number(LBA27-24)			
Command	CAh							

SILICONSYSTEMS PROPRIETARY

This document and the information contained within it is confidential and proprietary to SiliconSystems, Inc.
All unauthorized use and/or reproduction is prohibited.

Write Multiple — C5h

The Write Multiple command operates in the same manner as the Write Sector command. When issued, the device sets the BSY bit within 400ns and generates an interrupt at the completion of a transferred block of sectors. The DRQ bit is set at the beginning of a block transfer.

Table 72: Write Multiple — C5h

Register	D ₇	D ₆	D ₅	D ₄	D ₃	D ₂	D ₁	D ₀
Feature	X							
Sector Count	Sector Count							
Sector Number	Sector Number (LBA7-0)							
Cylinder Low	Cylinder Low(LBA15-8)							
Cylinder High	Cylinder High(LBA23-16)							
Drive Head	X	LBA	X	Drive	Head Number(LBA27-24)			
Command	C5h							

SILICONSYSTEMS PROPRIETARY

This document and the information contained within it is confidential and proprietary to SiliconSystems, Inc.
All unauthorized use and/or reproduction is prohibited.

Write Sector(s) — 30h, 31h

The Write Sector(s) command writes from 1 to 256 sectors as specified in the Sector Count register. A sector count of 0 requests 256 sectors. When issued, the device sets the BSY bit within 400ns and generates an interrupt at the completion of a transferred block of sectors. The DRQ bit is set at the beginning of a block transfer.

Table 73: Write Sector(s) — 30h, 31h

Register	D ₇	D ₆	D ₅	D ₄	D ₃	D ₂	D ₁	D ₀
Feature	X							
Sector Count	Sector Count							
Sector Number	Sector Number (LBA7-0)							
Cylinder Low	Cylinder Low (LBA15-8)							
Cylinder High	Cylinder High (LBA23-16)							
Drive Head	X	LBA	X	Drive	Head Number (LBA27-24)			
Command	30h or 31h							

SILICONSYSTEMS PROPRIETARY

This document and the information contained within it is confidential and proprietary to SiliconSystems, Inc.
All unauthorized use and/or reproduction is prohibited.

Write Long Sector(s) — 32h, 33h

The Write Long Sector(s) command operates in the same manner as the Write Sector command — when issued, the device sets the BSY bit within 400ns and generates an interrupt at the completion of a transferred block of sectors. The DRQ bit is set at the beginning of a block transfer.

Table 74: Write Long Sector(s) — 32h, 33h

Register	D ₇	D ₆	D ₅	D ₄	D ₃	D ₂	D ₁	D ₀
Feature	X							
Sector Count	Sector Count							
Sector Number	Sector Number (LBA7-0)							
Cylinder Low	Cylinder Low (LBA15-8)							
Cylinder High	Cylinder High (LBA23-16)							
Drive Head	X	LBA	X	Drive	Head Number (LBA27-24)			
Command	32h or 33h							

SILICONSYSTEMS PROPRIETARY

This document and the information contained within it is confidential and proprietary to SiliconSystems, Inc.
All unauthorized use and/or reproduction is prohibited.

Erase Sector(s) — C0h

The Erase Sector(s) command is issued prior to the issuance of a Write Sector(s) or Write Multiple w/o Erase command.

Table 75: Erase Sector(s) — C0h

Register	D ₇	D ₆	D ₅	D ₄	D ₃	D ₂	D ₁	D ₀
Feature	X							
Sector Count	Sector Count							
Sector Number	Sector Number (LBA7-0)							
Cylinder Low	Cylinder Low (LBA15-8)							
Cylinder High	Cylinder High (LBA23-16)							
Drive Head	X	LBA	X	Drive	Head Number (LBA27-24)			
Command	C0h							

SILICONSYSTEMS PROPRIETARY

This document and the information contained within it is confidential and proprietary to SiliconSystems, Inc.
All unauthorized use and/or reproduction is prohibited.

Request Sense — 03h

The Request Sense command identifies the extended error codes generated by the preceding ATA command. The Request Sense command must be issued immediately following the detection of an error via the Error register.

Table 76: Request Sense — 03h

Register	D ₇	D ₆	D ₅	D ₄	D ₃	D ₂	D ₁	D ₀
Feature					X			
Sector Count					X			
Sector Number					X			
Cylinder Low					X			
Cylinder High					X			
Drive Head	1	X	1	Drive			X	
Command								03h

The extended error codes are defined in the following table.

Table 77: Extended Error Codes

Extended Error Codes	Description
00h	No error detected
01h	Self test is OK (no error)
09h	Miscellaneous error
20h	Invalid command
21h	Invalid address (requested head or sector invalid)
2Fh	Address overflow (address too large)
35h, 36h	Supply or generated voltage out of tolerance
11h	Uncorrectable ECC error
18h	Corrected ECC error
05h, 30h-32h, 37h, 3Eh	Self test of diagnostic failed
10h, 14h	ID not found
3Ah	Spare sectors exhausted
1Fh	Data transfer error/aborted command
0Ch, 38h, 3Bh, 3Ch, 3Fh	Computed media format
03h	Write/erase failed

SILICONSYSTEMS PROPRIETARY

This document and the information contained within it is confidential and proprietary to SiliconSystems, Inc.
All unauthorized use and/or reproduction is prohibited.

Translate Sector — 87h

The Translate Sector command is not currently supported by the SiliconSystems' SiliconDrive. If the host issues this command, the device responds with 0x00h in the data register.

Table 78: Translate Sector — 87h

Register	D ₇	D ₆	D ₅	D ₄	D ₃	D ₂	D ₁	D ₀
Feature	X							
Sector Count	Sector Count							
Sector Number	Sector Number (LBA7-0)							
Cylinder Low	Cylinder Low (LBA15-8)							
Cylinder High	Cylinder High (LBA23-16)							
Drive Head	1	LBA	1	Drive	Head Number (LBA27-24)			
Command	87h							

SILICONSYSTEMS PROPRIETARY

This document and the information contained within it is confidential and proprietary to SiliconSystems, Inc.
All unauthorized use and/or reproduction is prohibited.

Wear-Level — F5h

The Wear-Level command is supported as an NOP command for the purposes of backward compatibility with the ANSI AT attachment standard. This command sets the Sector Count register to 0x00h.

Table 79: Wear-Level — F5h

Register	D ₇	D ₆	D ₅	D ₄	D ₃	D ₂	D ₁	D ₀
Feature	X							
Sector Count	Completion Status							
Sector Number	X							
Cylinder Low	X							
Cylinder High	X							
Drive Head	X	X	X	Drive	Flag			
Command	F5h							

SILICONSYSTEMS PROPRIETARY

This document and the information contained within it is confidential and proprietary to SiliconSystems, Inc.
All unauthorized use and/or reproduction is prohibited.

Write Multiple w/o Erase — CDh

The Write Multiple w/o Erase command functions identically to the Write Multiple command, with the exception that the implied pre-erase (i.e., Erase Sector(s) command) is not issued prior to writing the sectors.

Table 80: Write Multiple w/o Erase — CDh

Register	D ₇	D ₆	D ₅	D ₄	D ₃	D ₂	D ₁	D ₀
Feature	X							
Sector Count	Sector Count							
Sector Number	Sector Number (LBA7-0)							
Cylinder Low	Cylinder Low (LBA15-8)							
Cylinder High	Cylinder High (LBA23-16)							
Drive Head	X	LBA	X	Drive	Head Number (LBA27-24)			
Command	CDh							

SILICONSYSTEMS PROPRIETARY

This document and the information contained within it is confidential and proprietary to SiliconSystems, Inc.
All unauthorized use and/or reproduction is prohibited.

Write Sector(s) w/o Erase — 38h

The Write Sector(s) w/o Erase command functions similar to the Write Sector command, with the exception that the implied pre-erase (i.e., Erase Sector(s) command) is not issued prior to writing the sectors.

Table 81: Write Sector(s) w/o Erase — 38h

Register	D ₇	D ₆	D ₅	D ₄	D ₃	D ₂	D ₁	D ₀
Feature	X							
Sector Count	Sector Count							
Sector Number	Sector Number (LBA7-0)							
Cylinder Low	Cylinder Low (LBA15-8)							
Cylinder High	Cylinder High (LBA23-16)							
Drive Head	X	LBA	X	Drive	Head Number (LBA27-24)			
Command	38h							

SILICONSYSTEMS PROPRIETARY

This document and the information contained within it is confidential and proprietary to SiliconSystems, Inc.
All unauthorized use and/or reproduction is prohibited.

Write Verify — 3Ch

The Write Verify command verifies each sector immediately after it is written. This command performs identically to the Write Sector(s) command, with the added feature of verifying each sector written.

Table 82: Write Verify — 3Ch

Register	D ₇	D ₆	D ₅	D ₄	D ₃	D ₂	D ₁	D ₀
Feature	X							
Sector Count	Sector Count							
Sector Number	Sector Number (LBA7-0)							
Cylinder Low	Cylinder Low (LBA15-8)							
Cylinder High	Cylinder High (LBA23-16)							
Drive Head	X	LBA	X	Drive	Head Number (LBA27-24)			
Command	3Ch							

SILICONSYSTEMS PROPRIETARY

This document and the information contained within it is confidential and proprietary to SiliconSystems, Inc.
All unauthorized use and/or reproduction is prohibited.

SALES AND SUPPORT

To order or obtain information on pricing and delivery, contact your SiliconSystems Sales Representative.

PART NUMBERING

NOMENCLATURE

The following table defines the SiliconDrive PC Card part numbering scheme.

Table 83: Part Numbering Nomenclature

SSD-	P	YYY	T	<p>-3100 Part number suffix — contact your SiliconSystems' Sales Representative</p> <p>Temperature Range: <ul style="list-style-type: none"> • Blank = Commercial • I = Industrial </p> <p>Capacity: 32M = 32MB to 16G = 16GB</p>
<p>Form Factor: <ul style="list-style-type: none"> • C = CF • D = 2.5" Drive • M = Module • P = PC Card </p>				
SiliconSystems' SiliconDrive				

SILICONSYSTEMS PROPRIETARY

This document and the information contained within it is confidential and proprietary to SiliconSystems, Inc. All unauthorized use and/or reproduction is prohibited.

PART NUMBERS

The following table lists the SiliconDrive's part numbers.

Table 84: Part Numbers

Part Number	Capacity
SSD-P16G(I)-3100	16GB
SSD-P08G(I)-3100	8GB
SSD-P04G(I)-3100	4GB
SSD-P02G(I)-3100	2GB
SSD-P01G(I)-3100	1GB
SSD-P51M(I)-3100	512MB
SSD-P25M(I)-3100	256MB
SSD-P12M(I)-3100	128MB
SSD-P64M(I)-3100	64MB
SSD-P32M(I)-3100	32MB

SAMPLE LABEL

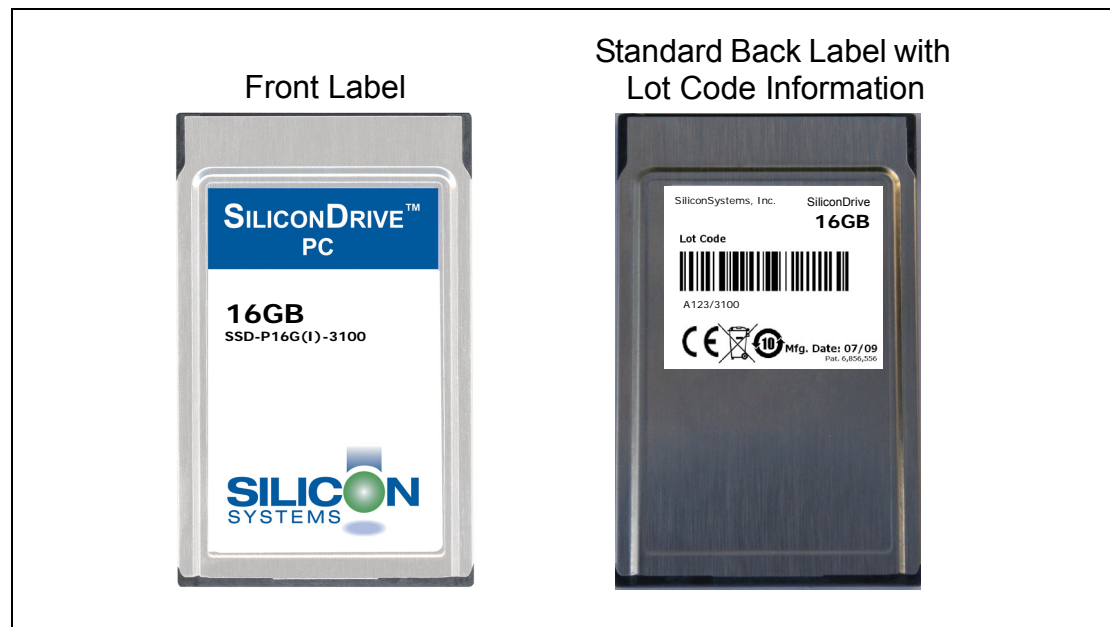

Figure 8: Sample Label

SILICONSYSTEMS PROPRIETARY

This document and the information contained within it is confidential and proprietary to SiliconSystems, Inc.
All unauthorized use and/or reproduction is prohibited.

RELATED DOCUMENTATION

For more information, visit www.siliconsystems.com or contact your SiliconSystems Sales Representative.

Table 85: Related Documentation

SiliconDrive		
Application-Specific Description		Document Number
Technology		
PowerArmor	Eliminates drive corruption.	WP-007-0xR
SiSMART	Calculates remaining useful life.	WP-008-0xR
SiProtect	Protection software for password-required, read/write, or read-only access.	WP-003-0xR
SiSweep	Ultra-fast data erasure.	SiSecure-0xANR
SiPurge	Non-recoverable data erasure.	SiSecure-0xANR

SiliconSystems' performance tests, ratings, and product specifications are measured using specific computer systems and/or components and reflect the approximate performance of SiliconSystems' products as measured by those tests. Any difference in system hardware or software design or configuration, as well as system use, may affect actual test results, ratings, and product specifications. SiliconSystems welcomes user comments and reserves the right to revise this document and/or make updates to product specifications, products, or programs described without notice at any time. SiliconSystems makes no representations or warranties regarding this document. The names of actual companies and products mentioned herein are the trademarks of their respective owners.

SiliconSystems®, SiliconDrive®, SiliconDrive II®, SiSecure®, SiliconDrive EP®, PowerArmor®, SiSMART®, SiKey™, SiZone™, SiProtect™, SiSweep™, SiPurge™, SiScrub™, SiliconDrive USB Blade™, SolidStor™, and the SiliconSystems logo are trademarks or registered trademarks of SiliconSystems, Inc. and may be used publicly only with the permission of SiliconSystems and require proper acknowledgement. Other listed names and brands are trademarks or registered trademarks of their respective owners.

© Copyright 2009 by SiliconSystems, Inc. All rights reserved. No part of this publication may be reproduced without the prior written consent of SiliconSystems.

SILICONSYSTEMS PROPRIETARY

This document and the information contained within it is confidential and proprietary to SiliconSystems, Inc. All unauthorized use and/or reproduction is prohibited.