

**Model 2102**  
**Gas Alarm Panel**

**Sierra Monitor Corporation**  
**1991 Tarob Court, Milpitas, CA 95035**  
**(408) 262-6611 / (800) 727-4377**  
**Fax: 408-262-9042**  
**E-Mail: [sierra@sierramonitor.com](mailto:sierra@sierramonitor.com)**

**Model 2102**  
**Gas Alarm Panel**

**APPLICABILITY & EFFECTIVITY**

This manual provides instructions for the following Sierra Monitor products:

<u>Model</u>	<u>Description</u>
2102-00	Alarm Panel – 2 Channel
2102-01	Alarm Panel – 2 Channel with audible

## Table of Contents

<i>1.0</i>	<i>Product Description</i> .....	<i>1</i>
1.1	Introduction .....	1
1.2	Configuration .....	2
<i>2.0</i>	<i>Operation</i> .....	2
2.1	Installation.....	2
<i>3.0</i>	<i>Specifications</i> .....	<i>4</i>
<i>4.0</i>	<i>Warranty</i> .....	<i>5</i>

**1.0 Product Description**

**1.1 Introduction**

The Model 2102 is a dual Channel Gas Alarm Panel housed in a NEMA 12, JIC type enclosure. The unit provides DC power for two SMC fixed installation gas monitors of the 200x or 20x series and also provides tow individual relays for activation of remote devices such as alarms, lights or fans. LED indicator on the front of the panel provides visual indication of the “SAFE” or “ALARM” status of each monitor.

Once installed the Model 2102 requires no maintenance. The monitors require periodic calibration as explained in their respective instruction manuals.

The unit shipped with the power supply set for installations up to 500 feet from the Alarm Panel using 22-AWG cable. Longer cable installations (see specifications) can be accomplished by adjustment of the power supply voltage.

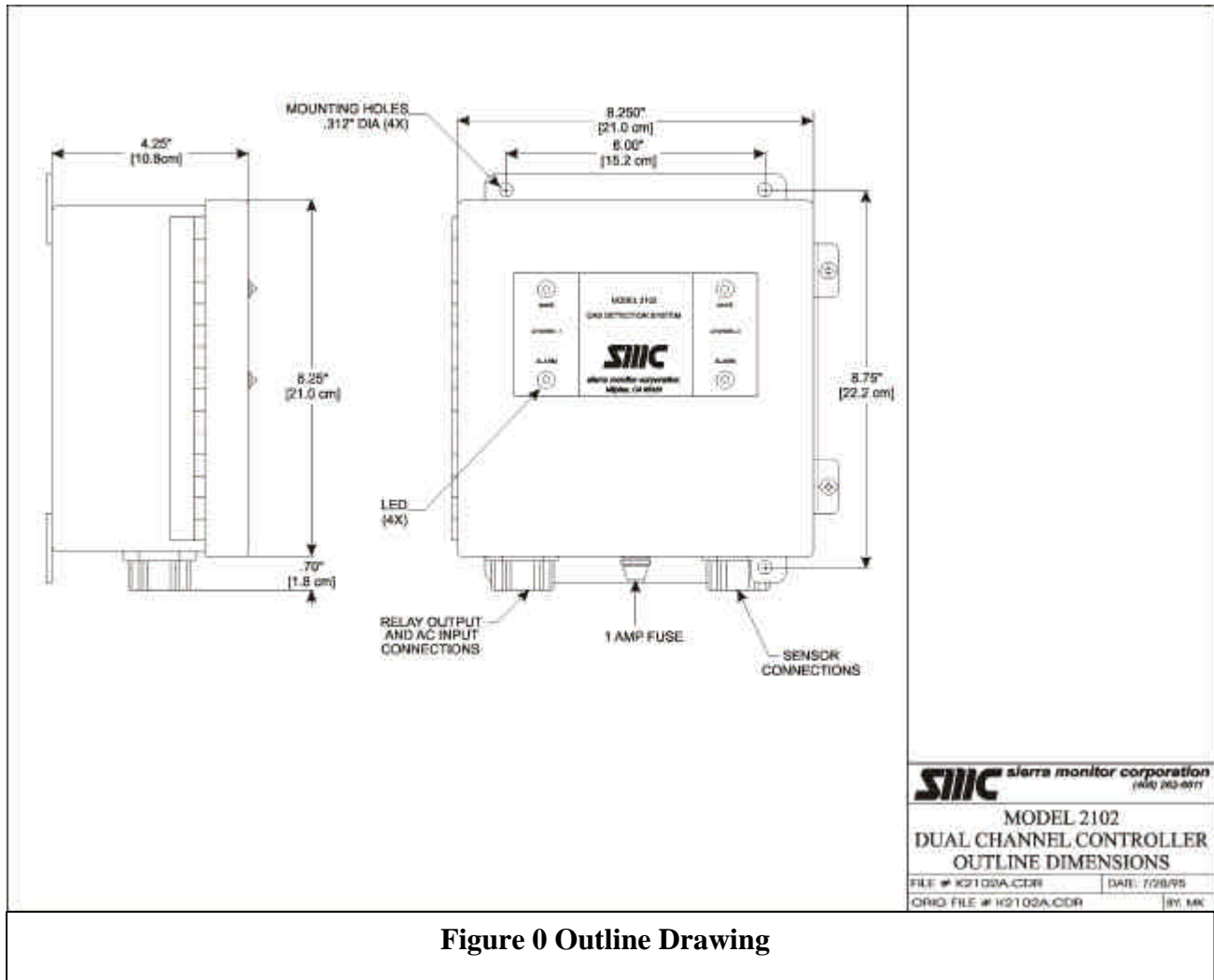

**Figure 0 Outline Drawing**

**1.2 Configuration**

The Model 2102 is available with or without a built in audible alarm at the controller:

Model 2102-00: Standard Controller.

Model 2102-01: Controller with audible alarm annunciator (common to both gas monitors) installed in the enclosure door.

The standard controller is provided with the relays configured for separate activation by their respective gas

monitors. (i.e.: Monitor #1 activates relay #1 and sensor #2 activates relay #2).

On request, the factory installs a jumper wire to re-configure the relays to activate on an “or” basis so that when either sensor alarms both relays energize. This jumper is indicated in the locator diagram and can be field installed by a technician.

Model 2102 connections as indicated in Table 2.

**2.0 Operation**

**2.1 Installation**

Determine suitable locations for the Model 2102 and the fixed gas monitors. Mount the panel at eye level using the mounting flanges on the top and bottom of the enclosure. Install ¾” electrical conduit from the right hand tub to the monitor locations. For installation convenience the wiring for both sensors can be run in the same conduit necessary. Pull four conductors for each monitor. See Table 1 for wire gauge requirements. The normal SMC color coding is green, red, black, white.

TERMINAL PIN	COLOR	FUNCTION
1	Green	Safe Signal
2	Red	+DC Voltage
3	Black	DC Common
4	White	Alarm Signal

**Table 2 Model 2102 Terminations**

Connect to the appropriate terminal strip pin # (as marked) in the fixed gas monitor.

**CAUTION:** The terminal strip positions in the gas monitor are marked with the correct numbers as they are not in logical sequence, insure that the wires are installed in the correspondingly numbered positions, not in logical sequence.

Connect ¾” conduit to the left hub of the enclosure to run 120 VAC power wiring to connect externally operated alarms, lights or fans to the relay terminal strips as required.

The relay terminal strips are identified as “J2” corresponding to Channel 1 and “J3” corresponding to Channel 2. The connections can be used as follows:

CABLE LENGTH	GAUGE	CONDUCTORS
500 feet	22 AWG	4
1,000 feet	18 AWG	4
1,500 feet	16 AWG	4

**Table 1 Sensor Cable Requirements**

Connect these wires to the terminal strip in the gas monitor and to the corresponding terminal in the gas monitor and to the corresponding terminal in the Central Panel. The four terminal barrier strips in the Model 2102 are marked “SENSOR 1” and “SENSOR 2” to correspond with the lights for Channels “1” and “2” on the front panel.

Terminal 1: Normally open: Connects to Commons during alarm.

Terminal 2: Common.

Terminal 3: Normally connected to Common: Opens during alarm.

Connect the 120 VAC power source to the large terminal strip marked “N” “G” “H” for Neutral, Ground, Hot. Install the protective plate which is provided with the Model 2102 over the AC Connection for safety.

As there is no “ON/OFF” switch on the central panel the system will start-up as soon as the supply AC is turned “ON”. Be sure that all sensor and relay

connections are completed prior to “power on”. When power is connected both channels will go into warm up mode as described in the gas monitor instruction manual. When the panel lights change to green the warm-up is complete and the system is in the normal monitoring mode.

If the monitors fail to operate correctly (see respective manual) measure the line voltage (terminals 2 and 3 at the monitor. If the voltage is below 9 VDC, increase the power supply voltage by adjusting the potentiometer (R11) on the controller board until the monitor receives 9 VDC minimum.

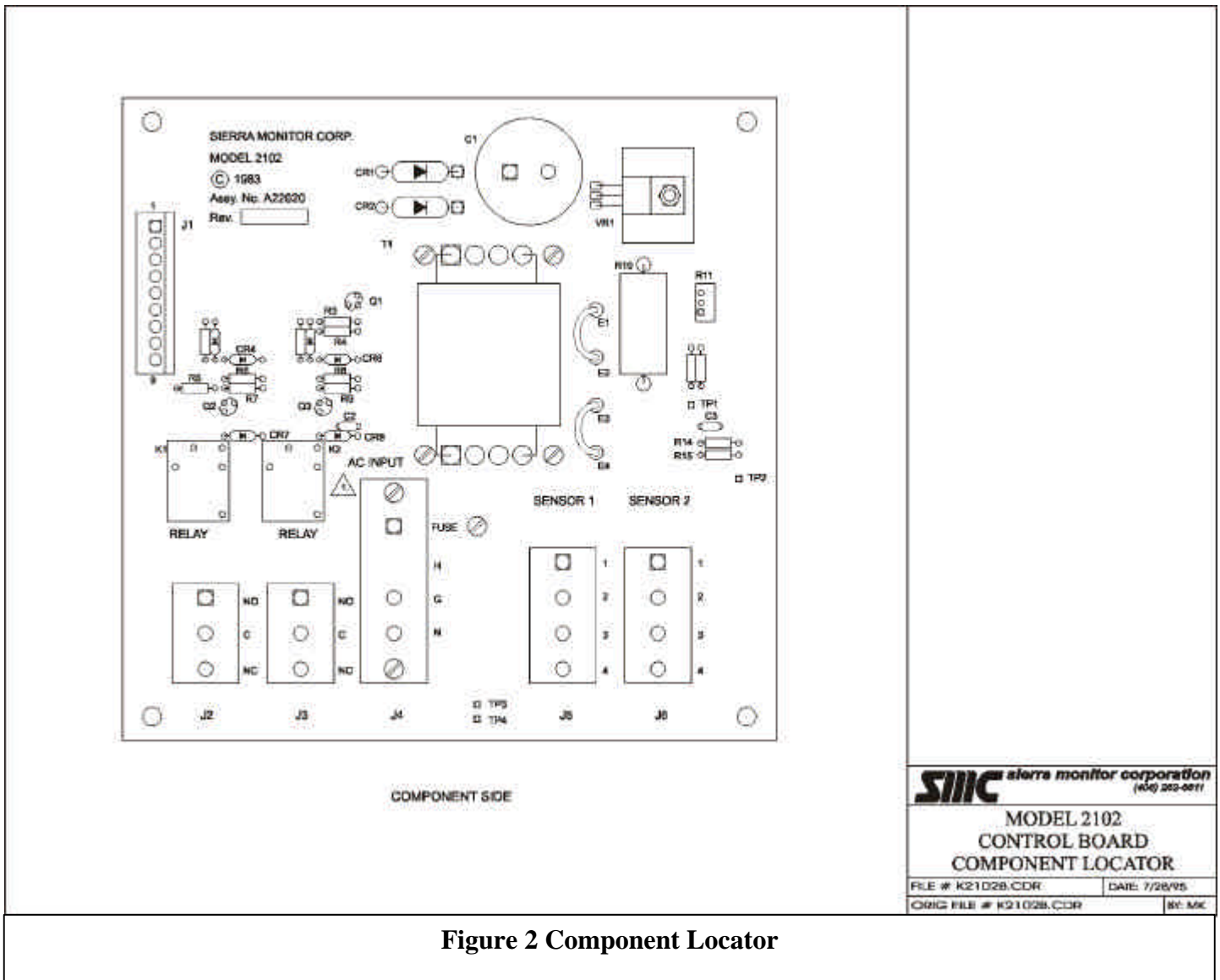

Figure 2 Component Locator

3.0 Specifications

Enclosure	NEMA 3, JIC Type
Operating Temperature	+32 <sup>0</sup> F to 113 <sup>0</sup> F (0 <sup>0</sup> C to +45 <sup>0</sup> C)
Input Power	120 VAC, 50-60 Hz 240 VAC available
Fuse	¼ Ampere
Size	8.3 x 8.3 x 4.4 in (HWD) (20.0 x 20.0 x 10.0 cm)
Output Voltage	9 – 13 VDC Adjustable
Output Current	350 mA DC/Channel
Relays	Tow 6 AMP dry contacts SPDT 300 VAC 28 VDC

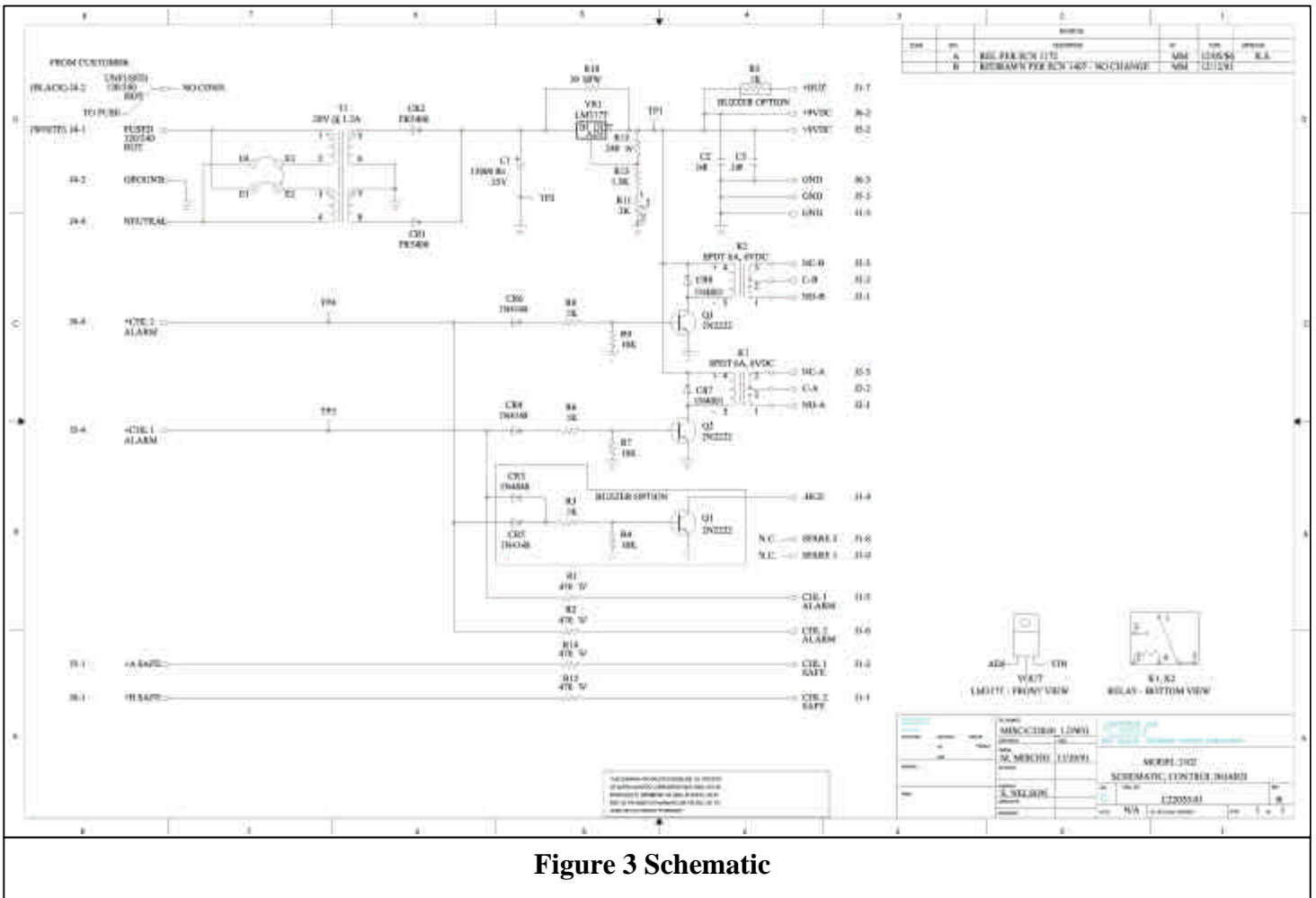

Figure 3 Schematic

#### **4.0 Warranty**

SIERRA MONITOR CORPORATION warrants its products to be free from defects in workmanship or material under normal use and service for two years after date of shipment. SMC will repair or replace without charge any equipment found to be defective during the warranty period. Final determination of the nature and responsibility for defective or damaged equipment will be made by SMC personnel.

All warranties hereunder are contingent upon proper use in the application for which the product was intended and do not cover products which have been modified or repaired without SMC approval or which have been subjected to accident, improper maintenance, installation or application, or on which original identification marks have been removed or altered. This Limited Warranty also will not apply to interconnecting cables or wires, consumables (ie. calibration gases, batteries, sensors), nor to any damage resulting from battery leakage.

In all cases SMC's responsibility and liability under this warranty shall be limited to the cost of the equipment. The purchaser must obtain shipping instructions for the prepaid return of any item under this warranty provision and compliance with such instruction shall be a condition of this warranty.

Except for the express warranty stated above, SMC disclaims all warranties with regard to the products sold hereunder including all implied warranties of merchantability and fitness and the express warranties stated herein are in lieu of all obligations or liabilities on the part of SMC for damages including, but not limited to, consequential damages arising out of/or in connection with the use or performance of the product.