

H8SX/1650 Series E6000H TFP-120
User System Interface Board

User's Manual

HS1650ECN61H

User's Manual

Rev.3.00
2003.10.6

RenesasTechnology
www.renesas.com

Cautions

Keep safety first in your circuit designs!

1. Renesas Technology Corp. puts the maximum effort into making semiconductor products better and more reliable, but there is always the possibility that trouble may occur with them. Trouble with semiconductors may lead to personal injury, fire or property damage. Remember to give due consideration to safety when making your circuit designs, with appropriate measures such as (i) placement of substitutive, auxiliary circuits, (ii) use of nonflammable material or (iii) prevention against any malfunction or mishap.

Notes regarding these materials

1. These materials are intended as a reference to assist our customers in the selection of the Renesas Technology Corp. product best suited to the customer's application; they do not convey any license under any intellectual property rights, or any other rights, belonging to Renesas Technology Corp. or a third party.
2. Renesas Technology Corp. assumes no responsibility for any damage, or infringement of any third-party's rights, originating in the use of any product data, diagrams, charts, programs, algorithms, or circuit application examples contained in these materials.
3. All information contained in these materials, including product data, diagrams, charts, programs and algorithms represents information on products at the time of publication of these materials, and are subject to change by Renesas Technology Corp. without notice due to product improvements or other reasons. It is therefore recommended that customers contact Renesas Technology Corp. or an authorized Renesas Technology Corp. product distributor for the latest product information before purchasing a product listed herein. The information described here may contain technical inaccuracies or typographical errors. Renesas Technology Corp. assumes no responsibility for any damage, liability, or other loss rising from these inaccuracies or errors. Please also pay attention to information published by Renesas Technology Corp. by various means, including the Renesas Technology Corp. Semiconductor home page (<http://www.renesas.com>).
4. When using any or all of the information contained in these materials, including product data, diagrams, charts, programs, and algorithms, please be sure to evaluate all information as a total system before making a final decision on the applicability of the information and products. Renesas Technology Corp. assumes no responsibility for any damage, liability or other loss resulting from the information contained herein.
5. Renesas Technology Corp. semiconductors are not designed or manufactured for use in a device or system that is used under circumstances in which human life is potentially at stake. Please contact Renesas Technology Corp. or an authorized Renesas Technology Corp. product distributor when considering the use of a product contained herein for any specific purposes, such as apparatus or systems for transportation, vehicular, medical, aerospace, nuclear, or undersea repeater use.
6. The prior written approval of Renesas Technology Corp. is necessary to reprint or reproduce in whole or in part these materials.
7. If these products or technologies are subject to the Japanese export control restrictions, they must be exported under a license from the Japanese government and cannot be imported into a country other than the approved destination. Any diversion or reexport contrary to the export control laws and regulations of Japan and/or the country of destination is prohibited.
8. Please contact Renesas Technology Corp. for further details on these materials or the products contained therein.

IMPORTANT INFORMATION

READ FIRST

- **READ this user's manual before using this user system interface board.**
- **KEEP the user's manual handy for future reference.**

Do not attempt to use the user system interface board until you fully understand its mechanism.

User System Interface Board:

Throughout this document, the term "user system interface board" shall be defined as the following product produced only by Renesas Technology Corp. excluding all subsidiary products.

- User system interface board (HS1650ECN60H)

The user system or a host computer is not included in this definition.

Purpose of the User System Interface Board:

This user system interface board is for connecting the evaluation chip board and user system. This user system interface board must only be used for the above purpose.

Improvement Policy:

Renesas Technology Corp. (including its subsidiaries, hereafter collectively referred to as Renesas) pursues a policy of continuing improvement in design, performance, functions, and safety of the user system interface board. Renesas reserves the right to change, wholly or partially, the specifications, design, user's manual, and other documentation at any time without notice.

Target User of the User System Interface Board:

This user system interface board should only be used by those who have carefully read and thoroughly understood the information and restrictions contained in the user's manual. Do not attempt to use the user system interface board until you fully understand its mechanism.

It is highly recommended that first-time users be instructed by users that are well versed in the operation of the user system interface board.

LIMITED WARRANTY

Renesas warrants its user system interface boards to be manufactured in accordance with published specifications and free from defects in material and/or workmanship. Renesas will repair or replace any user system interface boards determined to be defective in material and/or workmanship. User system interface boards are wearing parts which Renesas will not repair or replace if damaged and/or worn through use. The foregoing shall constitute the sole remedy for any breach of Renesas's warranty. This warranty extends only to you, the original Purchaser. It is not transferable to anyone who subsequently purchases the user system interface board from you. Renesas is not liable for any claim made by a third party or made by you for a third party.

DISCLAIMER

RENESAS MAKES NO WARRANTIES, EITHER EXPRESS OR IMPLIED, ORAL OR WRITTEN, EXCEPT AS PROVIDED HEREIN, INCLUDING WITHOUT LIMITATION THEREOF, WARRANTIES AS TO MARKETABILITY, MERCHANTABILITY, FITNESS FOR ANY PARTICULAR PURPOSE OR USE, OR AGAINST INFRINGEMENT OF ANY PATENT. IN NO EVENT SHALL RENESAS BE LIABLE FOR ANY DIRECT, INCIDENTAL OR CONSEQUENTIAL DAMAGES OF ANY NATURE, OR LOSSES OR EXPENSES RESULTING FROM ANY DEFECTIVE USER SYSTEM INTERFACE BOARD, THE USE OF ANY USER SYSTEM INTERFACE BOARD, OR ITS DOCUMENTATION, EVEN IF ADVISED OF THE POSSIBILITY OF SUCH DAMAGES. EXCEPT AS EXPRESSLY STATED OTHERWISE IN THIS WARRANTY, THIS USER SYSTEM INTERFACE BOARD IS SOLD "AS IS", AND YOU MUST ASSUME ALL RISK FOR THE USE AND RESULTS OBTAINED FROM THE USER SYSTEM INTERFACE BOARD.

State Law:

Some states do not allow the exclusion or limitation of implied warranties or liability for incidental or consequential damages, so the above limitation or exclusion may not apply to you. This warranty gives you specific legal rights, and you may have other rights which may vary from state to state.

The Warranty is Void in the Following Cases:

Renesas shall have no liability or legal responsibility for any problems caused by misuse, abuse, misapplication, neglect, improper handling, installation, repair or modifications of the user system interface board without Renesas's prior written consent or any problems caused by the user system.

All Rights Reserved:

This user's manual and user system interface board are copyrighted and all rights are reserved by Renesas. No part of this user's manual, all or part, may be reproduced or duplicated in any form, in hard-copy or machine-readable form, by any means available without Renesas's prior written consent.

Other Important Things to Keep in Mind:

1. Circuitry and other examples described herein are meant merely to indicate the characteristics and performance of Renesas's semiconductor products. Renesas assumes no responsibility for any intellectual property claims or other problems that may result from applications based on the examples described herein.
2. No license is granted by implication or otherwise under any patents or other rights of any third party or Renesas.

Figures:

Some figures in this user's manual may show items different from your actual system.

Limited Anticipation of Danger:

Renesas cannot anticipate every possible circumstance that might involve a potential hazard. The warnings in this user's manual and on the user system interface board are therefore not all inclusive. Therefore, you must use the user system interface board safely at your own risk.

SAFETY PAGE

READ FIRST

- **READ** this user's manual before using this user system interface board.
- **KEEP** the user's manual handy for future reference.

Do not attempt to use the user system interface board until you fully understand its mechanism.

DEFINITION OF SIGNAL WORDS



This is the safety alert symbol. It is used to alert you to potential personal injury hazards. Obey all safety messages that follow this symbol to avoid possible injury or death.



DANGER indicates an imminently hazardous situation which, if not avoided, will result in death or serious injury.



WARNING indicates a potentially hazardous situation which, if not avoided, could result in death or serious injury.



CAUTION indicates a potentially hazardous situation which, if not avoided, may result in minor or moderate injury.



CAUTION used without the safety alert symbol indicates a potentially hazardous situation which, if not avoided, may result in property damage.

NOTE emphasizes essential information.

WARNING

Observe the precautions listed below. Failure to do so will result in a FIRE HAZARD and will damage the user system and the emulator product or will result in PERSONAL INJURY. The USER PROGRAM will be LOST.

- 1. Do not repair or remodel the emulator product by yourself for electric shock prevention and quality assurance.**
- 2. Always switch OFF the E6000H emulator and user system before connecting or disconnecting any CABLES or PARTS.**
- 3. Always before connecting any BOARDS, make sure that pin 1 on both sides are correctly aligned.**

Preface

The HS1650ECN61H is a user system interface board that connects a user system for the H8SX/1650 Series TFP-120 package to the H8SX/1650 Series E6000H emulator (HS1650EPH60H).

Contents

Section 1	Configuration.....	1
Section 2	Connection Procedures	3
2.1	Connecting User System Interface Board to User System	3
2.1.1	Installing IC Socket.....	3
2.1.2	Soldering IC Socket	3
2.1.3	Installing IC Socket.....	4
2.1.4	Fastening IC Socket Connector.....	4
2.2	Exchanging the Spacer of the EV-Chip Board.....	6
2.3	Connecting User System Interface Board to EV-Chip Board	7
2.4	Recommended Dimensions for User System Mount Pad (Footprint)	9
2.5	Dimensions for EV-Chip Board and User System Interface Board.....	10
2.6	Resulting Dimensions after Connecting User System Interface Board	11
Section 3	Verifying Operation.....	12
Section 4	Notice.....	14

Section 1 Configuration

Figure 1 and table 1 show the configuration and components of the user system interface board for the TFP-120 package. Please make sure you have all of these components when unpacking.

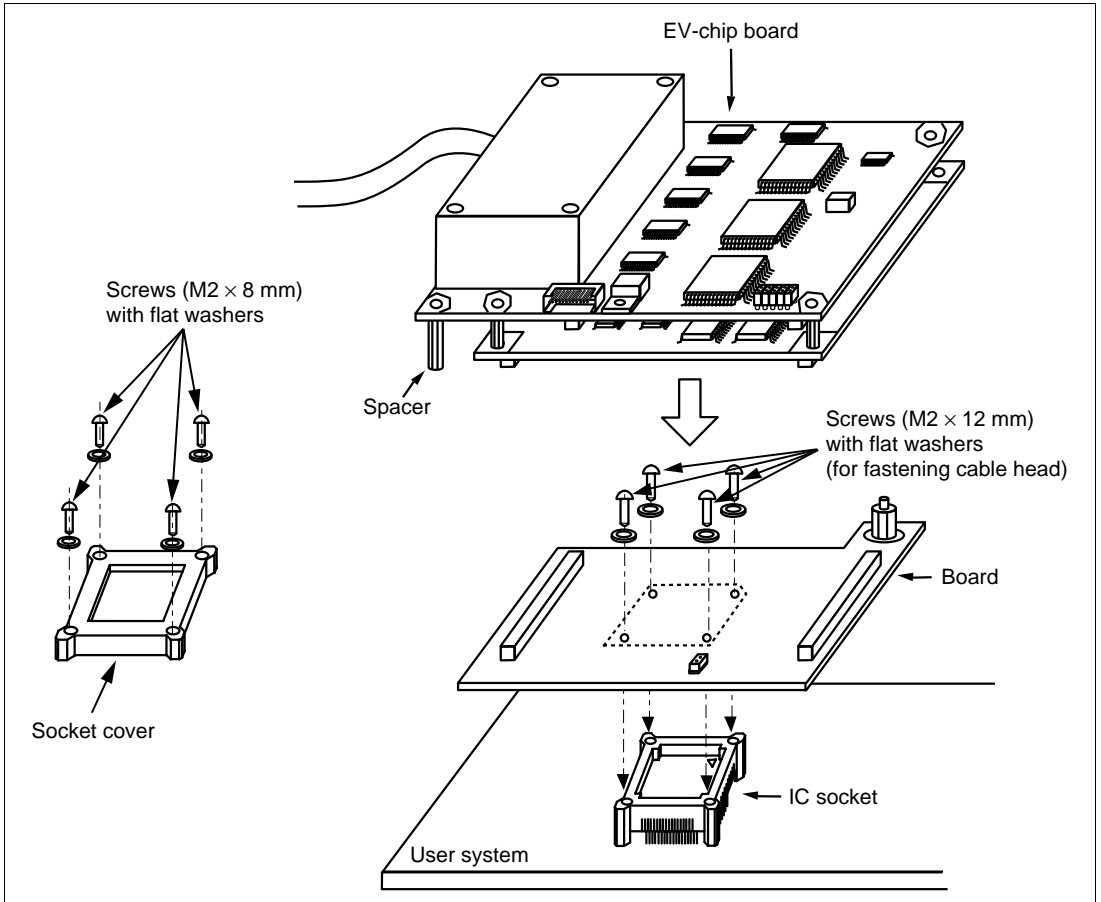

Figure 1 User System Interface Board for the H8SX/1650 Series TFP-120 Package

CAUTION

Use an IC149-120-043-B51 socket (manufactured by YAMAICHI ELECTRONICS Co., Ltd.) for the TFP-120 package IC socket on the user system.

Table 1 HS1650ECN61H Components

No.	Component	Quantity	Remarks
1	Board	1	
2	IC socket	1	For the TFP-120 package (to be mounted on the user system)
3	Socket cover	1	For installing an TFP-120-packaged MCU
4	Screw (M2 x 12 mm)	4	For fastening cable head (with four flat washers)
5	Screw (M2 x 8 mm)	4	For installing an TFP-120-packaged MCU (with four flat washers)
6	Spacers (2.6MP x 25 mm)	2	
7	User's manual	1	User's manual for HS1650ECN61H (this manual)

Section 2 Connection Procedures

2.1 Connecting User System Interface Board to User System

WARNING

Always switch OFF the user system and the emulator product before the USER SYSTEM INTERFACE BOARD is connected to or removed from any part. Before connecting, make sure that pin 1 on both sides are correctly aligned. Failure to do so will result in a FIRE HAZARD and will damage the user system and the emulator product or will result in PERSONAL INJURY. The USER PROGRAM will be LOST.

To connect the cable head to the user system, follow the instructions below.

2.1.1 Installing IC Socket

After checking the location of pin 1 on the IC socket, apply epoxy resin adhesive to the bottom of the IC socket for a TFP-120 package, and fasten it to the user system before soldering.

2.1.2 Soldering IC Socket

After fastening, solder the IC socket for a TFP-120 package to the user system. Be sure to completely solder the leads so that the solder slops gently over the leads and forms solder fillets. (Use slightly more solder than the MCU.)

2.1.3 Installing IC Socket

CAUTION

Check the location of pin 1 before inserting.

After checking the location of pin 1 on the user system interface board and pin 1 on the IC socket connector, align the guide pins on the IC socket connector with the guide holes on the user system interface board, and insert the IC socket connector into the IC socket (figure 2).

2.1.4 Fastening IC Socket Connector

CAUTION

- 1. Use the screwdriver provided for tightening screws.**
- 2. The tightening torque must be 0.294 N•m or less.
If the applied torque cannot be accurately measured, stop tightening when the force required to turn the screw becomes significantly greater than that needed when first tightening. If a screw is tightened too much, the screw head may break or an IC socket contact error may be caused by a crack in the IC socket solder.**
- 3. If the emulator does not operate correctly, cracks might have occurred in the solder. Check conduction with a tester and re-solder the IC socket if necessary.**

Fasten the user system interface board to the IC socket on the user system with four screws (M2 x 12 mm) provided.

Take special care, such as manually securing the IC socket soldered area, to prevent the soldered IC socket from being damaged by twisting the components.

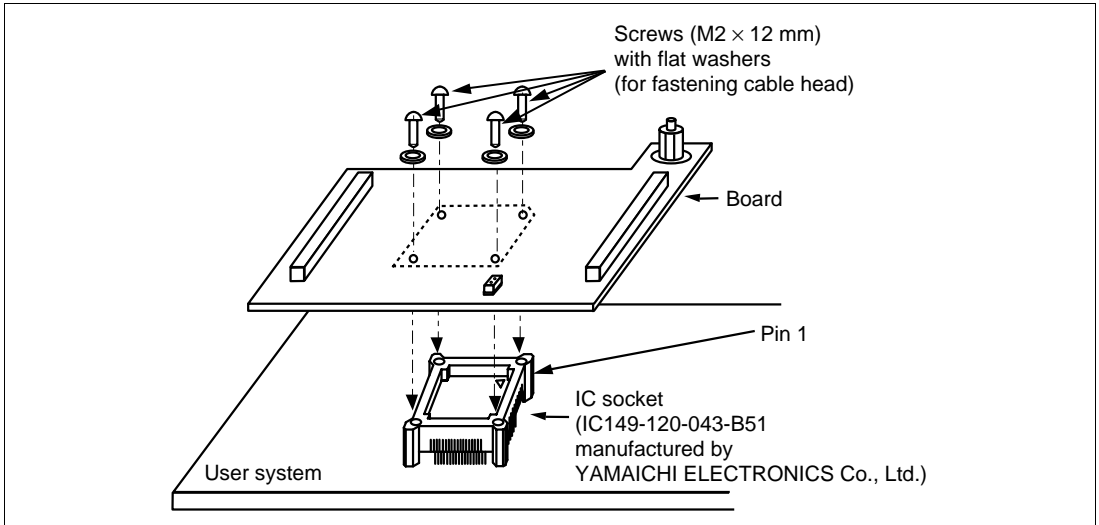

Figure 2 Connecting User System Interface Board to User System

2.2 Exchanging the Spacer of the EV-Chip Board

While the user system interface board is connected to the user system, be careful not to apply load.

Exchange the spacer (2.6MP × 10 mm) of the EV-chip board with another spacer (2.6MP × 25 mm) provided for the user system interface board.

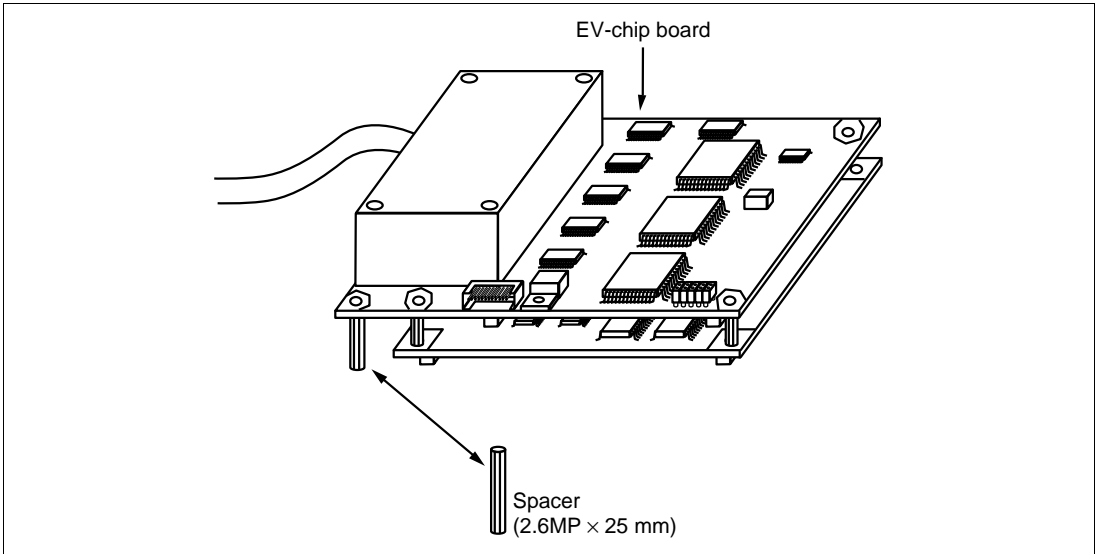

Figure 3 Exchanging the Spacer

2.3 Connecting User System Interface Board to EV-Chip Board

WARNING

Observe the precautions listed below. Failure to do so will result in a FIRE HAZARD and will damage the user system and the emulator product or will result in PERSONAL INJURY. The USER PROGRAM will be LOST.

- 1. Always switch OFF the user system and the emulator product before the USER SYSTEM INTERFACE BOARD is connected to or removed from any part. Before connecting, make sure that pin 1 on both sides are correctly aligned.**
- 2. The user system interface board dedicated to the emulator must be used.**

1. Make sure the user system and emulator are turned off.
2. Align the connectors on the board with those on the EV-chip board according to their numbers (figure 4).
3. Adjust the height of the spacer of the EV-chip board with the user system.

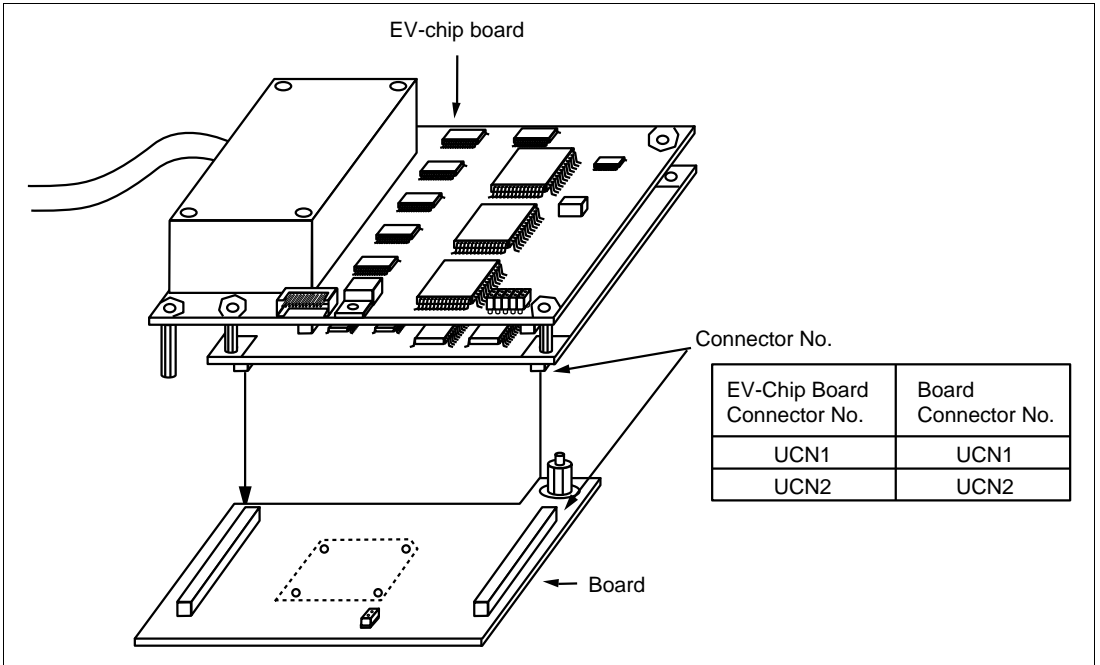

Figure 4 Connecting User System Interface Board to EV-Chip Board

2.4 Recommended Dimensions for User System Mount Pad (Footprint)

Figure 5 shows the recommended dimensions for the mount pad (footprint) for the user system with an IC socket for a TFP-120 package (IC149-120-043-B51: manufactured by YAMAICHI ELECTRONICS Co., Ltd). Note that the dimensions in figure 5 are somewhat different from those of the actual chip's mount pad.

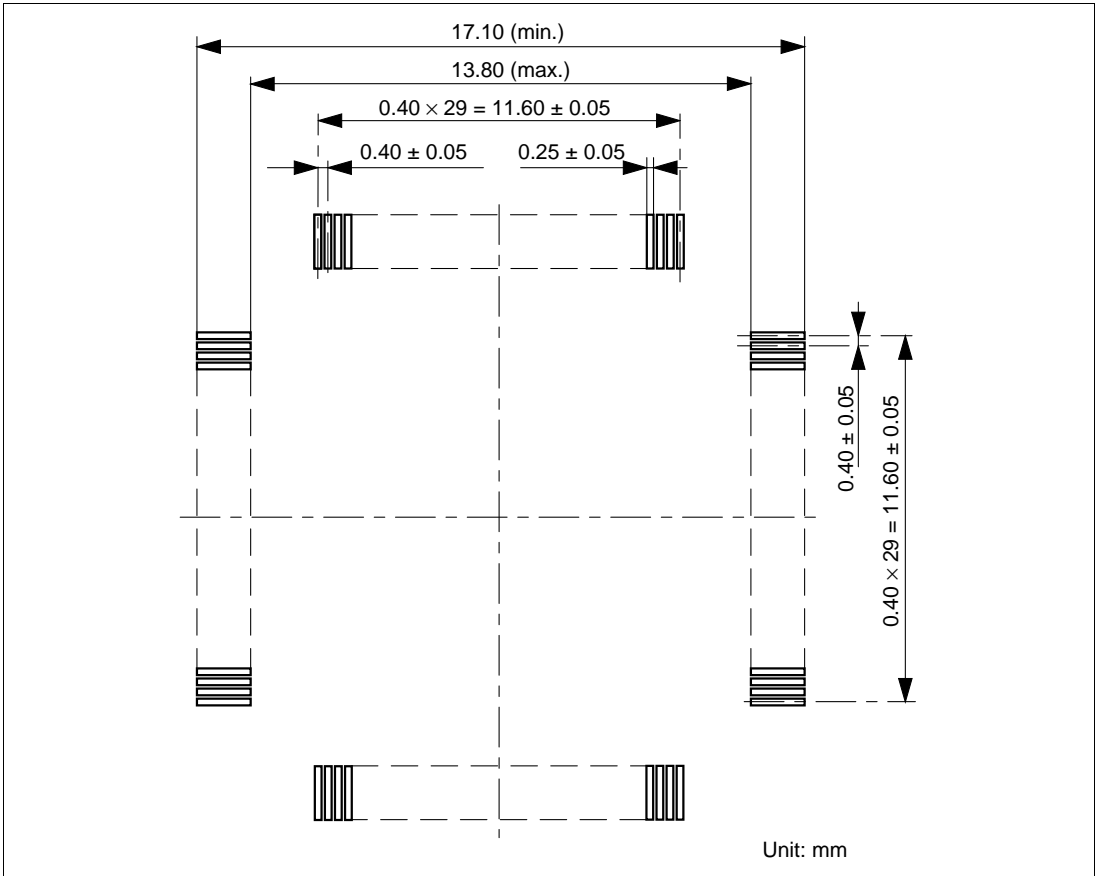

Figure 5 Recommended Dimensions for Mount Pad

2.5 Dimensions for EV-Chip Board and User System Interface Board

The dimensions for the EV-chip board and the user system interface board are shown in figure 6.

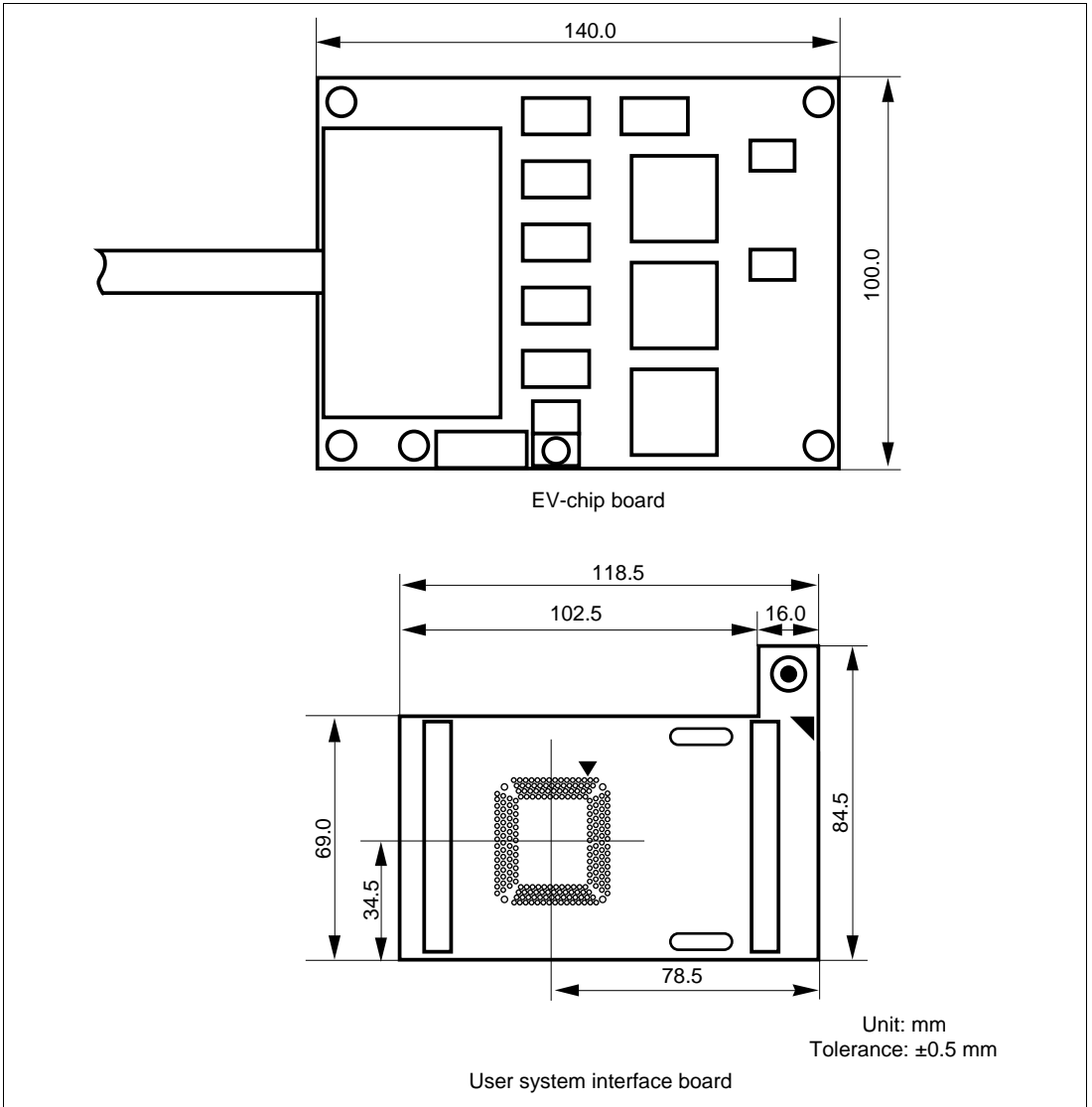

Figure 6 Dimensions for EV-Chip Board and User System Interface Board

2.6 Resulting Dimensions after Connecting User System Interface Board

The resulting dimensions, after connecting the user system interface board to the user system, are shown in figure 7.

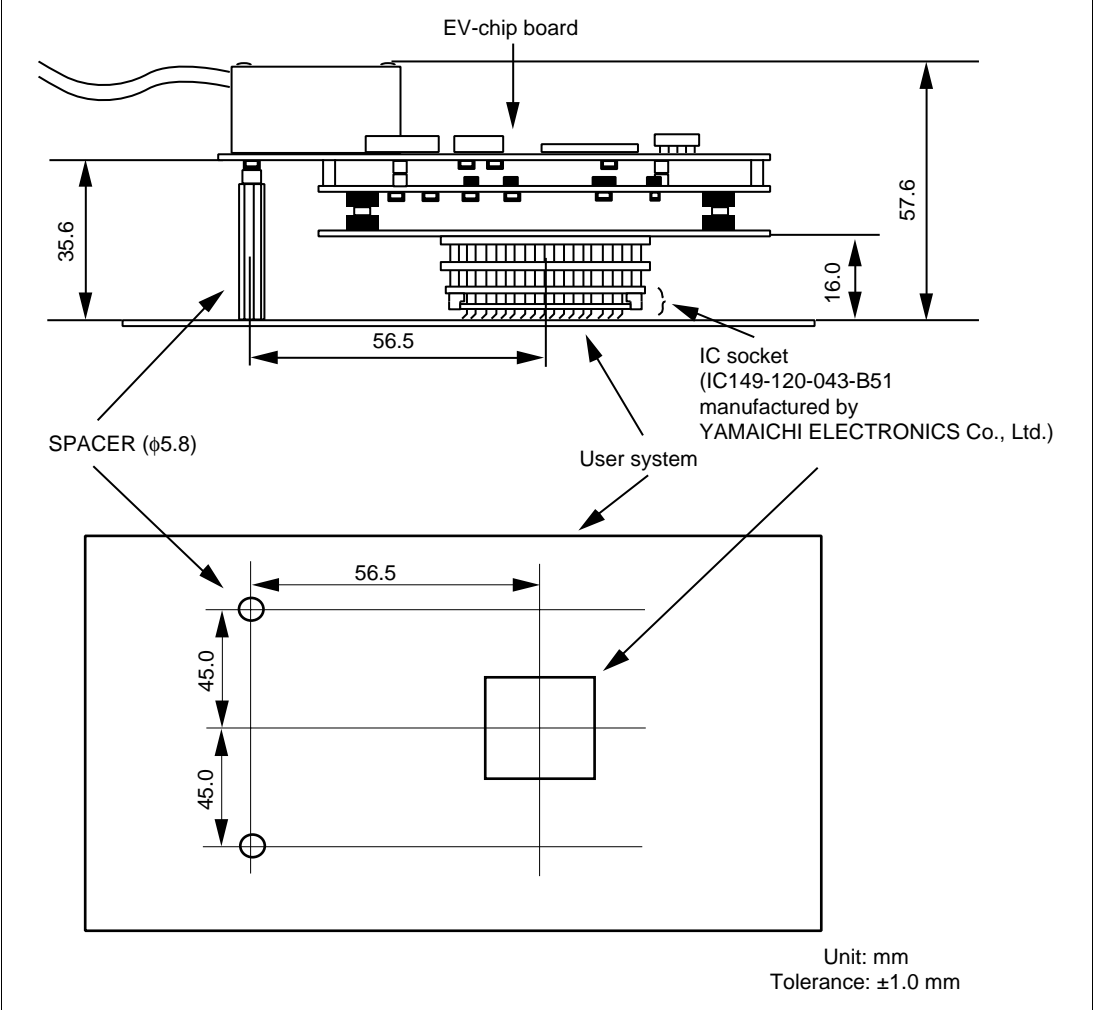

Figure 7 Resulting Dimensions after Connecting User System Interface Board

Section 3 Verifying Operation

1. Turn on the emulator according to the procedures described in the H8SX/1650 Series E6000H Emulator User's Manual (HS1650EPH60HE).
2. Verify the user system interface cable connections by checking the pin states with the CHECK command (emulator command) and checking the bus states with the FILL command (emulator command). If an error is detected, recheck the soldered IC socket and the location of pin 1.
3. The emulator connected to this user system interface board supports three kinds of clock sources as the MCU clock. For details, refer to the H8SX/1650 Series E6000H Emulator User's Manual (HS1650EPH60HE).
 - To use the emulator internal clock
Select the clock in the emulator by the CLOCK command (emulator command).
 - To use the external clock on the user system
Supply the external clock from the user system to the emulator by inputting the EXTAL pin (pin 84) on the user system interface board or connecting the crystal oscillator to the XTAL (pin 83) and EXTAL pins. For details, refer to the H8SX/1650 Hardware Manual.

Figure 8 shows the clock oscillator on the user system interface board.

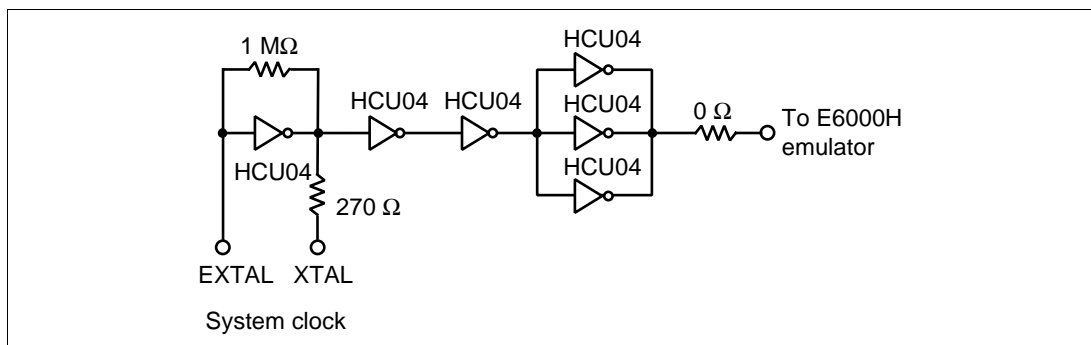

Figure 8 Clock Oscillator

- To use the crystal oscillator mounted on the EV-chip board
Install the crystal oscillator into the crystal oscillator terminals on the EV-chip board.

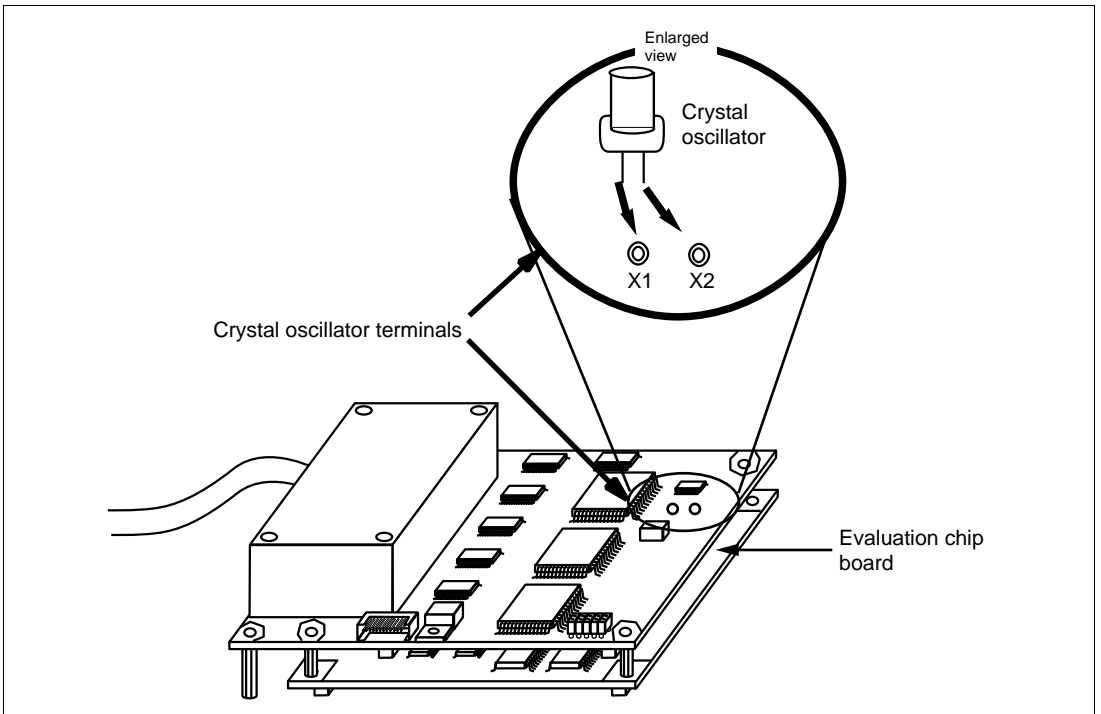

Figure 9 Installing the Clock Oscillator

Section 4 Notice

1. Before connecting any parts or cables, make sure that pin 1 on the both sides are correctly aligned.
2. Do not apply excessive force to the user system interface board while it is connected to the user system.
3. The dimensions of the recommended mount pad for the IC socket for this user system interface board are different from those of the MCU.
4. This user system interface board is specifically designed for the HS1650EPH60H emulator. Do not use this board with any other emulator.
5. When power is not supplied to the Vcc pin on the user system interface board, the emulator displays ** VCC DOWN. The emulator will not operate correctly.
6. The P1 short connector is used for testing. Do not remove the inserted jumper pin.

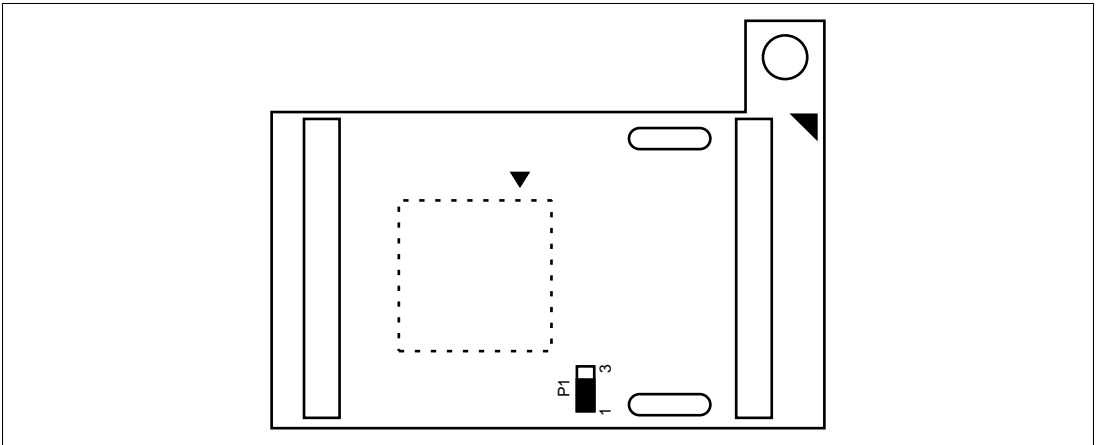

Figure 10 P1 Jumper Socket

H8SX/1650 Series E6000H TFP-120 User System Interface Board User's Manual

Publication Date: Rev.3.00, October 6, 2003

Published by: Sales Strategic Planning Div.
Renesas Technology Corp.

Edited by: Technical Documentation & Information Department
Renesas Kodaïra Semiconductor Co., Ltd.

H8SX/1650 Series E6000H TFP-120
User System Interface Board
User's Manual



Renesas Technology Corp.

2-6-2, Ote-machi, Chiyoda-ku, Tokyo, 100-0004, Japan

REJ10B0048-0300H