



Owner's Manual

- **SET-UP**
- **OPERATION**
- **MAINTENANCE**

**Walk Behind Mower
Model: T-439**

**IMPORTANT
Read Safety Rules and
Instructions Carefully**

CALLING CUSTOMER SUPPORT

- **LOCATE YOUR MODEL NUMBER AND SERIAL NUMBER** which appears on your unit and record the information in the space provided below.

IMPORTANT: You must have these numbers, along with the date and proof of purchase to receive warranty or service.

- If you are having difficulty assembling this product or if you have any questions regarding the controls, operation or maintenance of this unit, please call an authorized dealer.
- Please have your model number and serial number ready when you call.

NOTE: Although both numbers are important, you will be asked to enter only your serial number before your call can be processed.

↓ Model Number Numéro de modèle	Serial Number Numéro de série
XXX-XXXXXX	XXXXXXXXXXXX ↑
TROY-BILT TROYBILT - CANADA KITCHENER, ON N2G 4J1	

— This is where your model number will be, record Model Number here:

— This is where your serial number will be, record Serial Number here:

TABLE OF CONTENTS

CALLING CUSTOMER SUPPORT	2
IMPORTANT SAFE OPERATION PRACTICES	3
SLOPE GAUGE	6
UNPACKING	7
CONTENTS OF HARDWARE PACK	7
CONTROLS	10
OPERATION	11
ADJUSTMENT	13
LUBRICATION	14
MAINTENANCE	14
OFF SEASON STORAGE INSTRUCTIONS	15
TROUBLE SHOOTING	16
REPLACEMENT PARTS	17
REPLACEMENT PARTS	18
WARRANTY	22

This unit has been inspected against the manufacturers quality check list. In case of a discrepancy, please call us. We will make every effort to ship the part(s) by courier within one working day of your call.

IMPORTANT SAFE OPERATION PRACTICES



WARNING: This symbol points out important safety instructions which, if not followed, could endanger the personal safety and/or property of yourself and others. Read and follow all instructions in this manual before attempting to operate this machine. Failure to comply with these instructions may result in personal injury. When you see this symbol—  heed its warning.



DANGER: This machine was built to be operated according to the rules for safe operation in this manual. As with any type of power equipment, carelessness or error on the part of the operator can result in serious injury. This machine is capable of amputating hands and feet and throwing objects. Failure to observe the following safety instructions could result in serious injury or death.

GENERAL OPERATION

- Read, understand, and follow all instructions on the machine and in the manual(s) before attempting to assemble and operate. Keep this manual in a safe place for future and regular reference and for ordering replacement parts.
- Be familiar with all controls and their proper operation. Know how to stop the machine and disengage them quickly.
- Never allow children under 14 years old to operate this machine. Children 14 years old and over should read and understand the operation instructions and safety rules in this manual and should be trained and supervised by a parent.
- Never allow adults to operate this machine without proper instruction.
- To help avoid blade contact or a thrown object injury, keep bystanders, helpers, children and pets at least 75 feet from the machine while it is in operation. Stop machine if anyone enters the area.
- Thoroughly inspect the area where the equipment is to be used. Remove all stones, sticks, wire, bones, toys and other foreign objects which could be tripped over or picked up and thrown by the blade. Thrown objects can cause serious personal injury.
- Plan your mowing pattern to avoid discharge of material toward roads, sidewalks, bystanders and the like. Also, avoid discharging material against a wall or obstruction which may cause discharged material to ricochet back toward the operator.
- Always wear safety glasses or safety goggles during operation and while performing an adjustment or repair to protect your eyes. Thrown objects which ricochet can cause serious injury to the eyes.
- Wear sturdy, rough-soled work shoes and close-fitting slacks and shirts. Shirts and pants that cover the arms and legs and steel-toed shoes are recommended. Never operate this machine in bare feet, sandals, slippery or light weight (e.g. canvas) shoes.
- Many injuries occur as a result of the mower being pulled over the foot during a fall caused by slipping or tripping. Do not hold on to the mower if you are falling; release the handle immediately.
- Never pull the mower back toward you while you are walking. If you must back the mower away from a wall or obstruction first look down and behind to avoid tripping and then follow these steps:
 - a) Step back from the mower to fully extend your arms.
 - b) Be sure you are well balanced with sure footing.
 - c) Pull the mower back slowly, no more than half way toward you.
 - d) Repeat these steps as needed.
- Do not operate the mower while under the influence of alcohol or drugs.
- Do not put hands or feet near rotating parts or under the cutting deck. Contact with the blade can amputate hands and feet.
- A missing or damaged discharge cover can cause blade contact or thrown object injuries.
- Do not engage the self-propelled mechanism on units so equipped while starting engine.
- Never attempt to make a wheel or cutting height adjustment while the engine is running.

- The blade control handle is a safety device. Never attempt to bypass its operation. Doing so makes the safety device inoperative and may result in personal injury through contact with the rotating blade. The blade control handle must operate easily in both directions and automatically return to the disengaged position when released.
- Never operate the mower in wet grass. Always be sure of your footing. A slip and fall can cause serious personal injury. If you feel you are losing your footing, release the blade control handle immediately and the blade will stop rotating within three seconds.
- Mow only in daylight or in good artificial light. Walk, never run.
- Stop the blade when crossing gravel drives, walks or roads.
- If the equipment should start to vibrate abnormally, stop the engine and check immediately for the cause. Vibration is generally a warning of trouble.
- Shut the engine off and wait until the blade comes to a complete stop before removing the grass catcher or unclogging the chute. The cutting blade continues to rotate for a few seconds after the engine is shut off. Never place any part of the body in the blade area until you are sure the blade has stopped rotating.
- Never operate mower without proper trail shield, discharge cover, grass catcher, blade control handle or other safety protective devices in place and working. Never operate mower with damaged safety devices. Failure to do so, can result in personal injury.
- Muffler and engine become hot and can cause a burn. Do not touch.
- Only use parts and accessories made for this machine by the manufacturer. Failure to do so, can result in personal injury.
- If situations occur which are not covered in this manual, use care and good judgment. Contact your customer support department.

SLOPE OPERATION

Slopes are a major factor related to slip and fall accidents which can result in severe injury. Operation on slopes requires extra caution. If you feel uneasy on a slope, do not mow it. For your safety, use the slope gauge included as part of this manual to measure slopes before operating this unit on a sloped or hilly area. If the slope is greater than 15 degrees, do not mow it.

DO:

- Mow across the face of slopes; never up and down. Exercise extreme caution when changing direction on slopes. Watch for holes, ruts, bumps, rocks, or other hidden objects which can cause you to slip or trip. Tall grass can hide obstacles. Always be sure of your footing. A slip and fall can cause serious personal injury. If you feel you are losing your balance, release the blade control handle immediately, and the blade will stop rotating within 3 seconds.

DO NOT:

- Do not mow near drop-offs, ditches or embankments, you could lose your footing or balance.
- Do not mow slopes greater than 15 degrees as shown on the slope gauge.
- Do not mow on wet grass. Unstable footing could cause slipping.

CHILDREN

- Tragic accidents can occur if the operator is not alert to the presence of children. Children are often attracted to the mower and the mowing activity. They do not understand the dangers. Never assume that children will remain where you last saw them.
 - a) Keep children out of the mowing area and under the watchful care of a responsible adult other than the operator.
 - b) Be alert and turn mower off if a child enters the area.
 - c) Before and while moving backwards, look behind and down for small children.
 - d) Use extreme care when approaching blind corners, doorways, shrubs, trees, or other objects that may obscure your vision of a child who may run into the mower.
 - e) Keep children away from hot or running engines. They can suffer burns from a hot muffler.
- Never allow children under 14 years old to operate a power mower. Children 14 years old and over should read and understand the operation instructions and safety rules in this manual and should be trained and supervised by a parent.

SERVICE SAFE HANDLING OF GASOLINE:

- To avoid personal injury or property damage use extreme care in handling gasoline. Gasoline is extremely flammable and the vapors are explosive. Serious personal injury can occur when gasoline is spilled on your-

self or your clothes which can ignite. Wash your skin and change clothes immediately.

- a) Use only an approved gasoline container.
- b) Never fill containers inside a vehicle or on a truck or trailer bed with a plastic liner. Always place containers on the ground away from your vehicle before filling.
- c) When practical, remove gas-powered equipment from the truck or trailer and refuel it on the ground. If this is not possible, then refuel such equipment on a trailer with a portable container, rather than from a gasoline dispenser nozzle.
- d) Keep the nozzle in contact with the rim of the fuel tank or container opening at all times until fueling is complete. Do not use a nozzle lock-open device.
- e) Extinguish all cigarettes, cigars, pipes and other sources of ignition.
- f) Never fuel machine indoors.
- g) Never remove gas cap or add fuel while the engine is hot or running. Allow engine to cool at least two minutes before refueling.
- h) Never over fill fuel tank. Fill tank to no more than ½ inch below bottom of filler neck to provide space for fuel expansion.
- i) Replace gasoline cap and tighten securely.
- j) If gasoline is spilled, wipe it off the engine and equipment. Move unit to another area. Wait 5 minutes before starting the engine.
- k) Never store the machine or fuel container inside where there is an open flame, spark or pilot light as on a water heater, space heater, furnace, clothes dryer or other gas appliances.
- l) To reduce fire hazard, keep machine free of grass, leaves, or other debris build-up. Clean up oil or fuel spillage and remove any fuel soaked debris.
- m) Allow machine to cool at least 5 minutes before storing.

GENERAL SERVICE:

- Never run an engine indoors or in a poorly ventilated area. Engine exhaust contains carbon monoxide, an odorless and deadly gas.
- Before cleaning, repairing, or inspecting, make certain the blade and all moving parts have stopped. Disconnect the spark plug wire and ground against the engine to prevent unintended starting.
- Check the blade and engine mounting bolts at frequent intervals for proper tightness. Also, visually inspect blade for damage (e.g., bent, cracked, worn) Replace blade with the original equipment manufacturer's (O.E.M.) blade only, listed in this manual. "Use of parts which do not meet the original equipment specifications may lead to improper performance and compromise safety!"
- Mower blades are sharp and can cut. Wrap the blade(s) or wear gloves, and use extra caution when servicing them.
- Keep all nuts, bolts, and screws tight to be sure the equipment is in safe working condition.
- Never tamper with safety devices. Check their proper operation regularly.
- After striking a foreign object, stop the engine, disconnect the spark plug wire and ground against the engine. Thoroughly inspect the mower for any damage. Repair the damage before starting and operating the mower.
- Grass catcher components, discharge cover, and trail shield are subject to wear and damage which could expose moving parts or allow objects to be thrown. For safety protection, frequently check components and replace immediately with original equipment manufacturer's (O.E.M.) parts only, listed in this manual. "Use of parts which do not meet the original equipment specifications may lead to improper performance and compromise safety!"
- Do not change the engine governor setting or overspeed the engine. The governor controls the maximum safe operating speed of the engine.
- Maintain or replace safety and instruction labels, as necessary.
- Observe proper disposal laws and regulations. Improper disposal of fluids and materials can harm the environment.

SI-102
1-17-02

OWNER'S
MANUAL



SAFETY LABEL



WARNING - Your Responsibility:

Restrict the use of this power machine to persons who read, understand and follow the warnings and instructions in this manual and on the machine.

SLOPE GAUGE

(Keep this sheet in a safe place for future reference.)

USE THIS SHEET AS A GUIDE TO DETERMINE SLOPES WHERE YOU MAY NOT OPERATE SAFELY.

SIGHT AND HOLD THIS LEVEL WITH A VERTICAL TREE
A POWER POLE

A CORNER OF A BUILDING
OR A FENCE POST

FOLD ON DOTTED LINE, REPRESENTING A 15° SLOPE

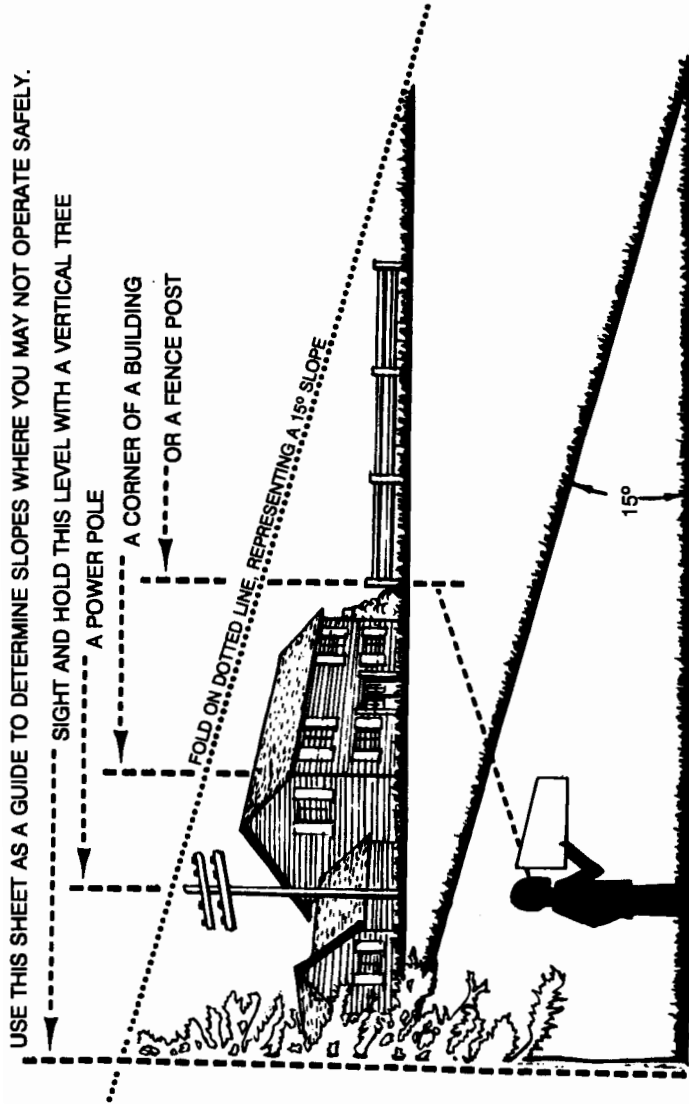

⚠ DANGER

Do not mow on inclines with a slope in excess of 15 degrees (a rise of approximately 2½ feet every 10 feet). A riding mower could overturn and cause serious injury. If operating a walk-behind mower on such a slope, it is extremely difficult to maintain your footing and you could slip, resulting in serious injury.

Operate RIDING mowers up and down slopes, never across the face of slopes.

Operate WALK-BEHIND mowers across the face of slopes, never up and down slopes.

CONTENTS OF HARDWARE PACK

Lay out the hardware according to the illustration for identification purposes. Part numbers are shown in parentheses. (Some parts may not be required for your unit).

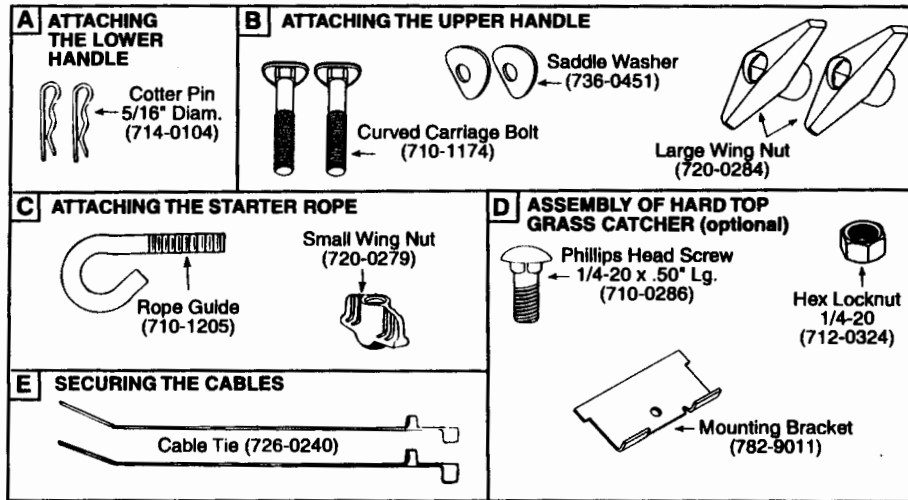

Figure 1

It is suggested that this manual be read in its entirety before attempting to assemble or operate. Keep this manual in a safe place for future reference and for ordering replacement parts.

This unit is shipped **WITHOUT GASOLINE or OIL**. After assembly, service engine with gasoline and oil as instructed in the separate engine manual packed with your unit.

Your mower is a precision piece of power equipment, not a play thing. Therefore, exercise extreme caution at all times.

Tools Required for Assembly

- (1) 7/16" Wrenches (with optional hard top grasscatcher bag only)

UNPACKING

1. Remove the lawn mower and all parts from the carton. Make certain all parts and literature have been removed from the carton before the carton is discarded.

CAUTION: DISCONNECT SPARK PLUG WIRE. IF THE WIRE IS NOT EQUIPPED WITH A RUBBER BOOT, SEE SEPARATE ENGINE MANUAL FOR GROUNDING PROCEDURE.

CAUTION: DO NOT BEND OR KINK CONTROL WIRE.

2. Refer to Figure 1 for hardware identification.

ATTACHING THE LOWER HANDLE (Hardware A)

1. There is an off-set hole in the lower handle to provide you with two handle height adjustments. Handles mounted with the notch (see inset, figure 1) forward or upward will be lower than handles mounted with the notch towards the rear of the unit.
2. Place the lower handle assembly on the mower. The holes in the handle fit over the pins on the deck bracket.
3. Secure with cotter pins in the inner holes in the weld pins. See figure 2.

ATTACHING THE UPPER HANDLE (See Hardware B)

1. Place the upper handle in position over the lower handle. The blade control must be on the upper side of the handle and the control box should be on the left side.
2. Secure the upper handle to the lower handle using curved carriage bolts, saddle washers and large wing nuts, see figure 3.

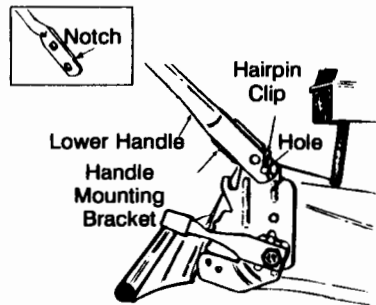

Figure 2

NOTE: Wing nuts should be mounted on the inside.

ATTACHING THE STARTER ROPE (Hardware C)

1. The recoil starter is inside the top of the engine. Additional rope may be wound around the starter handle. If so, unwind the rope from the handle.
2. With the spark plug wire disconnected and grounded, depress the starter control button fully with your thumb.

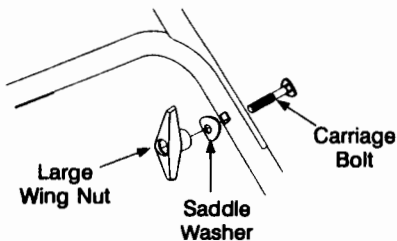

Figure 3

3. Using your other hand, pull the control handle all the way towards the upper handle and pull the recoil starter rope out of the engine.
4. Place the rope guide around the recoil starter handle, so the opening in the rope guide bolt is toward the front of the mower as shown. Insert the rope guide into the right side of the handle.
5. Secure with small wing nut. See figure 4.

NOTE: If the starter rope becomes disconnected from rope guide on handle, disconnect and ground the spark plug wire. Depress the blade control handle and pull the starter rope out from engine slowly. Slip the starter rope into the rope guide bolt on handle.

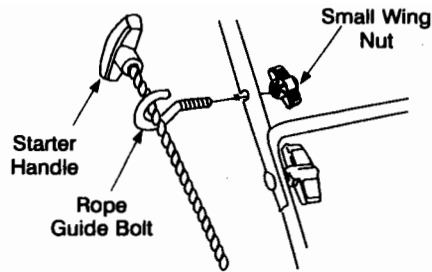

Figure 4

SECURING THE CABLES (Hardware E)

Secure the cable to the left side of the handle as follows.



WARNING: When attaching the control cables, the cables must be routed to avoid contact with all sharp edges and hot surfaces to prevent damage to the cables, which will render the control inoperative.

1. Insert posts on cable ties into holes provided on the lower handle. The holes may be either on the inside or outside of the handles. See figure 5A.
2. Secure the cables with the cable ties. See figure 5B. Trim excess ends of cable ties.

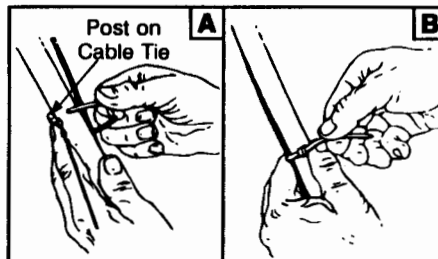

Figure 5

FINAL ASSEMBLY OF MOWER

Make certain all nuts and bolts are tightened securely.

ASSEMBLY OF GRASS CATCHER

(Soft Grass Bag)

NOTE: Make certain the grass bag is turned right side out before assembling (warning label will be on the outside).

1. Join the rear frame and front frame assembly as shown in figure 6A.

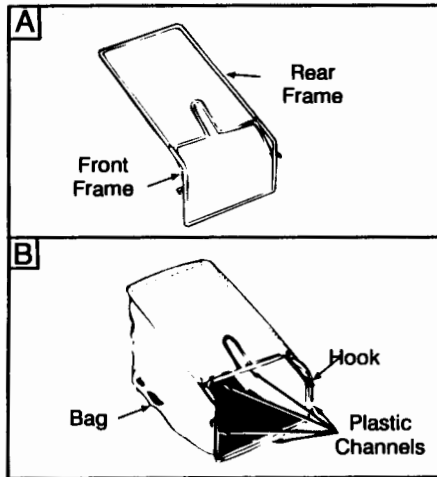

Figure 6

- Place bag over frame (black plastic side is the bottom of bag.) Slip the openings in the side of the plastic channel on bag over the hooks on the grass catcher frame.
- Secure bag to frame by working the plastic channels on bag over frame as shown in figure 6B. All of the plastic channels except center top of bag attach from the outside of bag. Center top of bag attaches from the inside of bag.

Hard Grass Bag (Hardware D)(optional)

- Insert one end of the rear frame into the cloth channel on the edge of the grass bag. See figure 7. Feed all the material on one side of the frame before working it around frame.
- Slide the ends of the front frame assembly into the ends of the rear frame as shown in figure 8.
- Slip the openings in the side of the plastic channel on bag over hooks on the grass catcher frame. See figure 8.
- Secure front of bag to front frame by working the plastic channels on sides and bottom of bag over frame.
- Slide the handle on the grass catcher frame into the slot in the hardtop cover from beneath the cover. See figure 9.
- Place the mounting bracket under the front of the handle, with the tabs on the bracket facing up. Insert phillips head screw down through the hardtop cover and mounting bracket. Secure with hex locknut. See figure 10.

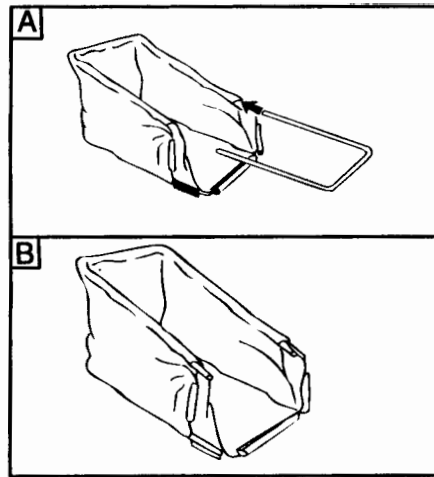

Figure 7

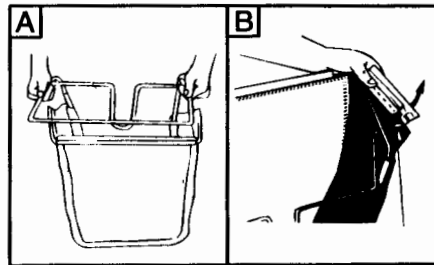

Figure 8

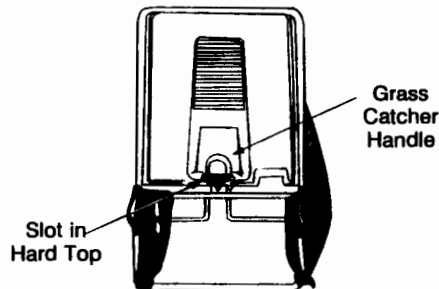

Figure 9

ATTACHING GRASS CATCHER TO MOWER

- Lift the rear discharge door on the mower, and remove the rear mulching plug. See figure 11.

NOTE: Make certain cables are routed to the outside of the handle so they are not in the way when attaching the grass catcher.

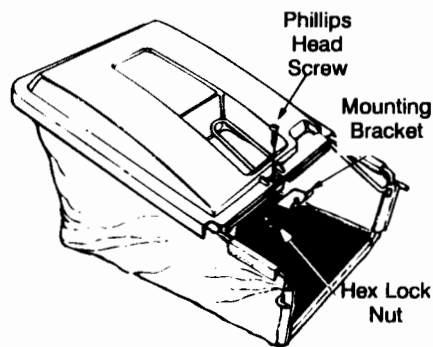

Figure 10

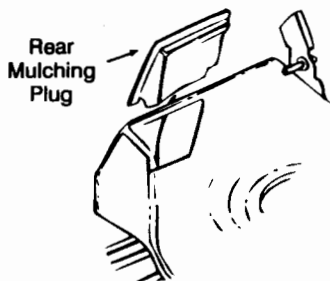

Figure 11

2. Place the hooks on the grass catcher into the slots in the handle bracket assemblies. See figure 12. Release the rear discharge door.

TO REMOVE THE GRASS CATCHER

Lift the rear discharge door on the mower. Lift the grass catcher up, out of the slots in the handle bracket assemblies. Release the rear discharge door.

! WARNING: Never operate the mower unless the hooks on the grass catcher are seated in the

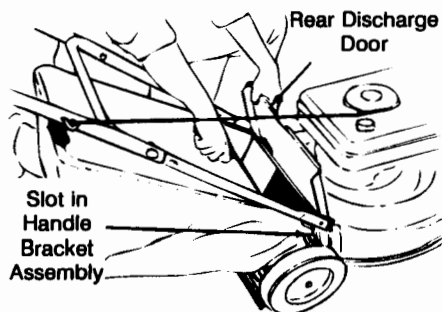

Figure 12

slots on the handle bracket assemblies, and the rear discharge door rests firmly against the top of the grass catcher.

CAUTION: Do not run your lawn mower without chute deflector or an approved grass catcher in place. The deflector will deflect a projectile thrown by the blade into the lawn.

CONVERTING TO SIDE DISCHARGE

If your unit is equipped with a side discharge deflector, you can convert to a side discharge mower as follows:

1. Lift the rear discharge door and install the rear mulching plug. See figure 11.
2. On the side of the mower deck, lift the hinged mulching plug. See Figure 13.

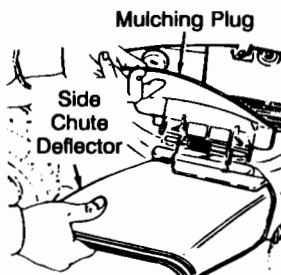

Figure 13

3. Slide the two hooks on the side discharge deflector under the hinge pin on the hinged mulching plug assembly.
4. Lower the hinged mulching plug.

NOTE: Do not remove the hinged mulching plug at any time, even when you are not mulching.

! WARNING: All mowers are equipped with a rear protective guard. The guard helps eliminate projectiles thrown by the blade from injuring the operator. **DO NOT REMOVE THIS GUARD.**

CONTROLS

! WARNING: Be familiar with all controls and their proper operation. Know how to stop the machine and disengage them quickly.

Safety Key

The safety key is located on the engine. The safety key is a safety device used to activate and deactivate the self starter system. The

self starter system will not work without the key in its proper position. See engine manual for further information pertaining to the safety key.



NOTE: The safety key must be in the run position to start the mower for both systems, either the self starter or recoil starter.

Blade Control Handle

WARNING: The blade control handle is a safety device. Never attempt to bypass its operations. Doing so, may result in personal injury through contact with the rotating blade. The blade rotates whenever the engine is running and when the self starter is de-energized.

The blade control handle is located on the upper handle of the mower. See Figure 14. The blade control handle and starter control button must be depressed in order to operate the unit. Release the blade control handle to stop the engine and blade and to energize the self starter.

Recoil Starter

The recoil starter handle is attached to the upper handle. See Figure 4. The recoil starter is used to start the engine when the self starter is in the de-energized mode.

Start Control Button

The start control button is located on the upper left side of the handle. See Figure 14. The start control button must be depressed fully while pulling the blade control handle toward upper handle for the engine to start. The starter control button will automatically return to the off/ up position once the blade control handle is released.

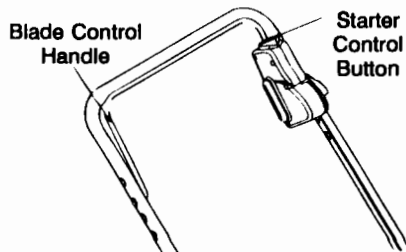

Figure 14

NOTE: The starter button must be depressed to start the engine with either the self starter or recoil starting system.

OPERATION

WARNING: Read, understand, and follow all instructions and warnings on the machine and in this manual before operating.

Keep hands and feet away from the discharge area on and from under the cutting deck.

The operation of any lawn mower can result in foreign objects being thrown into the eyes, which can result in severe eye damage. Always wear safety glasses or eye shields.

NOTE: For best results raise the cutting position until it is determined which height is best for your lawn. See Cutting Height Adjustment section.

BEFORE STARTING

Service the engine with gasoline and oil as instructed in the separate engine manual packed in your mower. Read instructions carefully.

WARNING: Never fill fuel tank indoors, with engine running or until the engine has been allowed to cool for at least two minutes after running.

TO START ENGINE AND ENGAGE BLADE

- Attach spark plug wire to spark plug. If unit is equipped with a rubber boot over the end of the spark plug wire, make certain the metal loop on the end of the spark plug wire (inside the rubber boot) is fastened securely over the metal tip on the spark plug. See figure 15.

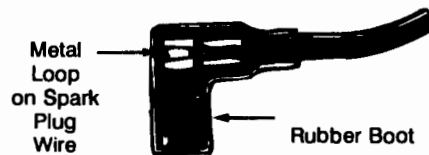



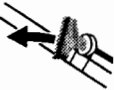

Figure 15

First Time Starting Engine



NOTE: Use recoil starter rope to start engine for the very first time. The mower is shipped with the safety key in the locked and de-energized mode, follow instructions as follows.

1. Place lawn mower on a level surface out-doors.
2. Remove clear plastic packaging under fuel cap.
3. Open shut off valve (if equipped) 1/4 turn.
4. Turn safety key 1/4 turn clockwise to RUN position. 
5. If your unit is equipped with a primer, prime engine as instructed in the separate engine manual packed with your unit. 
6. While standing in the operating position, depress the starter control button fully with the thumb of your right hand. 
7. Using your left hand, pull the control handle all the way toward the upper handle. See Figure 14. 
8. Release the button.
9. Grasp the recoil rope starter handle with your right hand and slowly pull towards you until you feel a slight resistance, then pull firmly until your arm is fully extended. 
10. If engine does not start by the second pull, repeat steps 5, 6, 7, 8 and 9.

Second Time Starting Engine

NOTE: Follow these instructions if the self starter is already in the energized mode.

-  **WARNING: NEVER assume starter is in the de-energized mode, even if the key is in the locked position and/or removed from the engine. ALWAYS de-energize starter prior to performing any maintenance or service to the engine and/or mower. Follow instructions on the engine and/or machine to de-energize starter.**

1. Check oil and fuel level and add if necessary.
2. Open shut off valve (if equipped) 1/4 turn.
3. Turn safety key 1/4 turn clockwise to RUN position. 
4. Firmly push primer bulb 3 times (For a cold engine only!). 
5. While standing at upper handle, depress and hold the starter control button with the thumb of your right hand. 

6. Using your left hand, pull the blade control handle all the way toward the upper handle. See Figure 14. Starter will de-energize and engine will start. 

(NOTE: If engine does not start, release the blade control handle and follow steps 5, 6, 7, 8 and 9 in the "First Time Starting Engine" instructions.)

NOTE: If any problems are encountered, refer to the Trouble Shooting Guide for helpful information.

To Stop Engine And Blade

1. Release safety blade control handle (the start control button will automatically return to the off/up position), engine and blade will stop within a few seconds.

NOTE: Engine may stop with a ratcheting sound. This sound is the self starter being reactivated/energized for the next start.
2. Turn safety key 1/4 turn counterclockwise to LOCK position. Remove key and store in a safe place.
3. Disconnect and ground the spark plug wire as instructed in the separate engine manual to prevent accidental starting while equipment is unattended.

 **WARNING: The blade will continue to rotate for three seconds after the blade control lever is released.**

To De-Energize Self Starter

- Remove spark plug wire from spark plug.
- Turn safety key to RUN position (1/4 turn clockwise).
- While standing in the operating position, depress the starter control button fully with the thumb of your right hand.
- Using your left hand, pull the control handle all the way toward the upper handle.
- Release button.

NOTE: Engine will crank over upon actuating equipment starting controls, but will not spark if spark plug wire was removed from spark plug as described above. Once engine has stopped cranking, self starter is de-energized.

 **WARNING: Self Starting System: If these instructions are not followed, amputation or severe laceration can result.**

- ALWAYS disconnect spark plug, de-energize starter, lock and remove safety key BEFORE performing ANY service to the engine or mower.
- DO NOT attempt any maintenance or repairs to the self starter.
- NEVER assume starter is de-energized, even if key is in LOCK AND REMOVE position and/or removed from engine.
- BEFORE removing grass or other debris from under mower deck; BEFORE changing oil, air filter or spark plug; BEFORE removing blade for servicing; BEFORE performing any other service to engine or mower; BEFORE transporting mower-ALWAYS DE-ENERGIZE SELF STARTER.
- ALWAYS lock and remove safety key and store in a safe place until next use. The safety key is designed and intended to be removed from engine when not in use. Removing key will prevent unsupervised or unexpected starting of mower by children or unsuspecting adults. The safety key must be in the locked position before it can be removed.

FOR THE BEST RESULTS WHEN MULCHING:

- Clear lawn of debris. Be sure that the lawn is clear of stones, sticks, wire or other foreign objects which could damage the lawnmower. Such objects could be accidentally thrown out by the mower in any direction and cause serious personal injury to the operator and others as well as damage to property and surrounding objects.
- Do not cut wet grass. For effective mulching do not cut wet grass because it tends to stick to the underside of the deck preventing proper mulching of the grass clippings.
- Cut no more than 1/3 the length of the grass. The recommended cut for mulching is 1/3 the length of the grass. Ground speed will need to be adjusted so the clippings can be dispersed evenly into the lawn. For especially heavy cutting in thick grass it may be necessary to use one of the slowest speeds in order to get a clean well mulched cut. When mulching long grass you may have to cut the lawn in two passes, lowering the blade another 1/3 of the length for the second cut and perhaps cutting in a different pattern than was used the first time. Overlapping the cut a little on each pass will also help to clean up any stray clippings left on the lawn. The mower should always be operated at full throttle to get the best cut and allow it to do the most effective job of mulching.
- Clean underside of deck. Be certain to clean the underside of the cutting deck after each use to

avoid a build-up of grass, which would prevent proper mulching.

- Mulching Leaves. The mulching of leaves can also be beneficial to your lawn. When mulching leaves make sure they are dry and are not laying too thick on the lawn. Do not wait for all the leaves to be off the trees before you mulch.
- It is recommended keeping driveways and sidewalks on the operators right while moving. Continue mowing using this pattern, having the left side of your lawnmower next to the uncut grass. Mulching with the cutting area of the mower on the lawn avoids grass clippings in undesirable areas.



WARNING: If you strike a foreign object, stop the engine. Remove wire from spark plug, thoroughly inspect the mower for any damage, and repair the damage before restarting and operating the mower. Extensive vibration of the mower during operation is an indication of damage. The unit should be promptly inspected and repaired.

ADJUSTMENT



WARNING: Be sure to disconnect the spark plug wire and DE-ENERGIZE starter before performing any adjustments or repairs. DO NOT attempt any maintenance or service to the engine and/or mower equipped with the safety key in the unlocked and/or energized mode.



WARNING: NEVER assume starter is de-energized, even if the key is in the locked position and/or removed from the engine. ALWAYS de-energize self starter prior to performing any maintenance or service to the engine and/or mower. Follow instructions on the engine and/or machine to de-energize starter

CAUTION : Before changing mowing height, stop mower and disconnect spark plug cable.

MODELS WITH NINE POSITION HEIGHT ADJUSTERS: (See Figure 16).

1. Stop mower and disconnect spark plug cable before changing mower cutting height.
2. The wheel adjusters give you nine (9) different cutting positions. Medium is the best for most mowers.



Figure 16

3. To change the height of cut, squeeze adjuster lever toward the wheel, moving up or down to selected height.

NOTE: All wheels must be in the same height of cut.

1. When cutting in heavy or moist grass, the rear of lawnmower may be raised higher to allow better discharge of the grass.

CARBURETOR ADJUSTMENT

Minor carburetor adjustment may be required to compensate for differences in fuel, temperature, altitude and load. Refer to the separate engine manual packed with your mower for carburetor adjustment information.

HANDLE HEIGHT ADJUSTMENT

Your mower has provisions for two handle height positions. The notch on the flat portion of the lower handle indicates which position the handle is in. If the notch is facing up or forward the handle is in the lower height and for the higher height the notch is facing down.

To change the height setting refer to "Attaching the Lower Handle".

LUBRICATION

CAUTION: DISCONNECT SPARK PLUG WIRE BEFORE SERVICING

1. **WHEELS** - Lubricate the ball bearings in each wheel at least once a season with a light oil.
2. **ENGINE** - Follow engine manual for lubrication instructions.
3. **BLADE CONTROL** - Lubricate the pivot points on the blade control handle and the brake cable at least once a season with light oil. The blade control must operate freely in both directions.

MAINTENANCE



WARNING: Be sure to disconnect the spark plug wire and DE-ENERGIZE starter before performing any adjustments or repairs. DO NOT attempt any maintenance or service to the engine and/or mower equipped with the safety key in the unlocked and/or energized mode.



WARNING: NEVER assume starter is de-energized, even if the key is in the locked position and/or removed from the engine. ALWAYS de-energize self starter prior to performing any maintenance or service to the

engine and/or mower. Follow instructions on the engine and/or machine to de-energize starter.

DECK

The underside of the mower deck should be cleaned after each use to prevent a buildup of grass clippings, leaves, dirt or other matter. If this debris is allowed to accumulate, it will invite rust and corrosion, and may prevent proper mulching.

The deck may be cleaned by tilting the mower and scraping clean with a suitable tool (make certain the spark plug wire is disconnected).

CUTTING BLADE



WARNING: Be sure to disconnect and ground the spark plug wire and remove ignition key before working on the cutting blade to prevent accidental engine starting. Protect hands by using heavy gloves or a rag to grasp the cutting blades.

Tip mower as specified in separate engine manual. If it is not specified tip with carburetor up.

Remove the bolt and blade support which holds the blade and adapter to the engine crankshaft. Remove the blade and adapter from the crankshaft.



WARNING: Periodically inspect the blade adapter for cracks, especially if you strike a foreign object. Replace when necessary.

For best results your blade should be sharp. The blade may be resharpened by removing it and either grinding or filing the cutting edge keeping as close to the original bevel as possible. It is extremely important that each cutting edge receives an equal amount of grinding to prevent an unbalanced blade. Improper blade balance will result in excessive vibration causing eventual damage to the engine and mower. Be sure to carefully balance blade after sharpening. The blade can be tested for balance by balancing it on a round shaft screwdriver. Remove metal from the heavy side until it balances evenly.

Before reassembling the blade and the blade adapter to the unit, lubricate the engine crankshaft and the inner surface of the blade adapter with light oil. Install the blade adapter on the crankshaft with the "star" away from the engine. Refer to figure 17. Place the blade with the side marked bottom (or with part number) facing away from the adapter. Align the blade bell support over the blade with the tabs in the holes of the

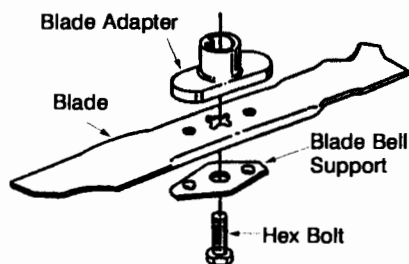

Figure 17

blade and insert the hex bolt. Tighten the hex bolt to the torque listed below:

Blade Mounting Torque

Center Bolt 450 in. lb. min., 600 in.lb. max.

To insure safe operation of your unit, ALL nuts and bolts must be checked periodically for correct tightness.

CAUTION: Cutting grass in sandy soil conditions causes abrasive wear to the blades.

After prolonged use, especially in sandy soil conditions, the blade will become worn and lose some of the original shape. Cutting efficiency will be reduced and the blade should be replaced. Replace with an approved factory replacement blade only. Possible damage resulting from blade unbalance condition is not the responsibility of the manufacturer.

ENGINE

Refer to the separate engine manual for engine maintenance instructions.

Maintain **engine oil** as instructed in the separate engine manual packed with your unit. Read and follow instructions carefully.

Service **air cleaner** as per separate engine manual under normal conditions. Clean every few hours under extremely dusty conditions. Poor engine performance and flooding usually indicates that the air cleaner should be serviced. To service the air cleaner, refer to the separate engine manual packed with your unit.

The **spark plug** should be cleaned and the gap reset once a season. Spark plug replacement is recommended at the start of each mowing season; check engine manual for correct plug type and gap specifications.

NOTE: This spark ignition system meets all requirements of the Canadian Interference-Causing Equipment Regulations.

Clean the engine regularly with a cloth or brush. Keep the cooling system (blower housing area) clean to permit proper air circulation which is essential to engine performance and life. Be certain to remove all grass, dirt and combustible debris from muffler area.

OFF SEASON STORAGE INSTRUCTIONS



WARNING: Be sure to disconnect the spark plug wire and **DE-ENERGIZE** starter before performing any adjustments or repairs. **DO NOT** attempt any maintenance or service to the engine and/or mower equipped with the safety key in the unlocked and/or energized mode.



WARNING: NEVER assume starter is de-energized, even if the key is in the locked position and/or removed from the engine. **ALWAYS** de-energize self starter prior to performing any maintenance or service to the engine and/or mower. Follow instructions on the engine and/or machine to de-energize starter

The following steps should be taken to prepare lawn mower for storage.

1. Clean and lubricate mower thoroughly as described in the lubrication instructions.
2. Refer to engine manual for correct engine storage instructions.
3. Coat mower's cutting blade with chassis grease to prevent rusting.
4. Store mower in a dry, clean area.

NOTE: When storing any type of power equipment in an unventilated or metal storage shed, care should be taken to rust-proof the equipment. Using a light oil or silicone, coat the equipment, especially cables and all moving parts.

NOTE: Be careful not to bend or kink cables.

NOTE: If the starter rope becomes disconnected from rope guide on handle, disconnect and ground the spark plug wire. Depress the blade control handle and pull the starter rope out from engine slowly. Slip the starter rope into the rope guide bolt on handle.

TROUBLE SHOOTING

PROBLEM	POSSIBLE CAUSE(S)	CORRECTIVE ACTION
Engine fails to start	<ol style="list-style-type: none"> 1. Blade control handle disengaged. 2. Spark plug wire disconnected. 3. Fuel tank empty, or stale fuel. 4. Blocked fuel line. 5. Faulty spark plug. 6. Engine flooded. 	<ol style="list-style-type: none"> 1. Engage blade control handle. 2. Connect spark plug wire. 3. Fill tank with clean, fresh gasoline. 4. Clean the fuel line. 5. Clean, adjust gap or replace. 6. Wait a few minutes to restart, but do not prime.
Engine runs erratic	<ol style="list-style-type: none"> 1. Spark plug wire loose. 2. Blocked fuel line or stale fuel. 3. Vent in gas plugged. 4. Water or dirt in fuel system. 5. Dirty air cleaner. 6. Carburetor out of adjustment. 	<ol style="list-style-type: none"> 1. Connect and tighten spark plug wire. 2. Clean the fuel line; fill the tank with clean, fresh gasoline. 3. Clear vent. 4. Drain the fuel tank and carburetor. Refill with fresh fuel. 5. Clean air cleaner. 6. Adjust carburetor.
Engine overheats	<ol style="list-style-type: none"> 1. Engine oil level low. 2. Air flow restricted. 3. Carburetor not adjusted properly. 	<ol style="list-style-type: none"> 1. Fill crankcase with proper oil. 2. Remove blower housing and clean. 3. Adjust carburetor.
Idles poorly	<ol style="list-style-type: none"> 1. Spark plug fouled, faulty or gap too wide. 2. Carburetor improperly adjusted. 3. Dirty air cleaner. 	<ol style="list-style-type: none"> 1. Reset gap to .030" or replace spark plug. 2. Adjust carburetor. 3. Clean air cleaner.
Excessive vibration	<ol style="list-style-type: none"> 1. Cutting blade loose or unbalanced. 2. Bent cutting blade. 	<ol style="list-style-type: none"> 1. Tighten blade and adapter. Balance blade. 2. Replace blade.
Mower will not mulch grass	<ol style="list-style-type: none"> 1. Wet grass. 2. Excessively high grass. 3. Dull blade. 	<ol style="list-style-type: none"> 1. Do not mow when grass is wet; wait until later to cut. 2. Mow once at a high cutting height, then mow again at desired height or make a narrower cutting path. 3. Sharpen or replace blade.
Uneven cut	<ol style="list-style-type: none"> 1. Wheels not positioned correctly. 2. Dull blade. 	<ol style="list-style-type: none"> 1. Place all four wheels in same height position. 2. Sharpen or replace blade.
Wheels will not propel	<ol style="list-style-type: none"> 1. Belt not installed properly. 2. Debris clogging drive operation. 	<ol style="list-style-type: none"> 1. Check belt for proper pulley installation and movement. 2. Clean out debris.

NOTE: For repairs beyond the minor adjustments listed above, contract your nearest authorized service dealer.