

# USER MANUAL

---

MODEL 1010A  
**Miniature, High Speed  
Short Range Modem  
with Transformer Isolation**



---

**PATTON**  
**Electronics Co.**

Part# 07M1010A-A  
Doc# 039011UA  
Revised 11/8/95

SALES OFFICE  
(301) 975-1000  
TECHNICAL SUPPORT  
(301) 975-1007

**APPENDIX D  
BLOCK DIAGRAM**

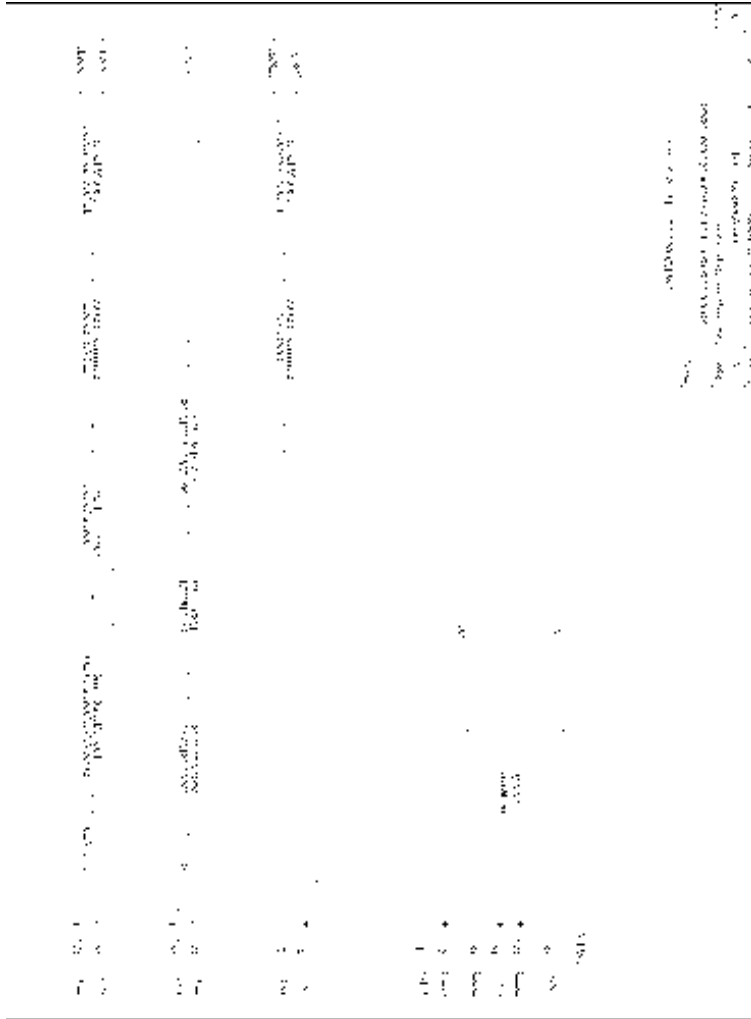

**1.0 WARRANTY INFORMATION**

**Patton Electronics** warrants all Model 1010A components to be free from defects, and will—at our option—repair or replace the product should it fail within one year from the first date of shipment.

This warranty is limited to defects in workmanship or materials, and does not cover customer damage, abuse or unauthorized modification. If this product fails or does not perform as warranted, your sole recourse shall be repair or replacement as described above. Under no condition shall **Patton Electronics** be liable for any damages incurred by the use of this product. These damages include, but are not limited to, the following: lost profits, lost savings, and incidental or consequential damages arising from the use of or inability to use this product. **Patton Electronics** specifically disclaims all other warranties, expressed or implied, and the installation or use of this product shall be deemed an acceptance of these terms by the user.

**1.1 RADIO AND TV INTERFERENCE**

The Model 1010A generates and uses radio frequency energy, and if not installed and used properly—that is, in strict accordance with the manufacturer's instructions—may cause interference to radio and television reception. The Model 1010A has been tested and found to comply with the limits for a Class A computing device in accordance with the specifications in Subpart J of Part 15 of FCC rules, which are designed to provide reasonable protection from such interference in a commercial installation. However, there is no guarantee that interference will not occur in a particular installation. If the Model 1010A does cause interference to radio or television reception, which can be determined by disconnecting the RS-232 interface, the user is encouraged to try to correct the interference by one or more of the following measures: moving the computing equipment away from the receiver, re-orienting the receiving antenna, and/or plugging the receiving equipment into a different AC outlet (such that the computing equipment and receiver are on different branches).

**1.2 SERVICE**

All warranty and non-warranty repairs must be returned freight prepaid and insured to Patton Electronics. All returns must have a Return Materials Authorization number on the outside of the shipping container. This number may be obtained from Patton Electronics Technical Service at **(301) 975-1007**. *Packages received without an RMA number will not be accepted.*

Patton Electronics' technical staff is also available to answer any questions that might arise concerning the installation or use of your Model 1010A. Technical Service hours: **8AM to 5PM EST, Monday through Friday.**

## 2.0 GENERAL INFORMATION

Thank you for your purchase of this Patton Electronics product. This product has been thoroughly inspected and tested and is warranted for One Year parts and labor. If any questions or problems arise during installation or use of this product, please do not hesitate to contact Patton Electronics Technical Support at (301) 975-1007.

### 2.1 FEATURES

- Transformer coupled for DC isolation between modems
- Immune to ground loops caused by ground potential differences
- Supports asynchronous RS-232 communication over 2 twisted pair
- Supports data rates to 115.2 Kbps, distances to 8.5 miles
- Loops back all handshaking signals on the RS-232 interface
- Externally accessible DCE/DTE switch makes configuration easy
- Very thin case (.75") for closely spaced computer ports
- No AC power or batteries required—draws all necessary operating power from the RS-232 interface
- Provides surge protection of 600 Watts per wire

### 2.2 DESCRIPTION

**The Patton Model 1010A miniature, high speed, transformer isolated short range modem** lets two asynchronous RS-232 devices communicate between buildings, over two twisted pair. Supporting asynchronous data rates to 115.2 Kbps, the Model 1010A derives the necessary power for operation from the data and control voltages on the RS-232 interface. DC transformer isolation on the line side gives the Model 1010A immunity to ground loops that would otherwise hamper between-building communications.

An external DCE/DTE switch lets you connect to the serial port of either a computer/terminal (DTE) or a modem (DCE) without using a crossover cable. The Model 1010A is available with three 4 wire interface options: RJ-11, RJ-45 or terminal blocks with strain relief.

The Model 1010A also incorporates high speed avalanche diodes that intercept data line transient surges and shunt them safely to chassis ground. With surge handling capacity of 600W per wire at 1mS, the 1010A can protect itself and connected equipment from nearby lightning strikes and other surges of electromagnetic radiation.

## APPENDIX C RS-232C PIN CONFIGURATIONS

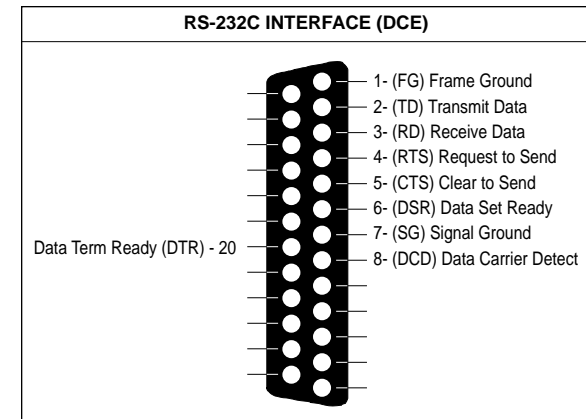

## APPENDIX B SPECIFICATIONS

**Transmission Format:** Asynchronous, full duplex

**Transmission Line:** Two unconditioned twisted pair 19 - 26 AWG

**Range:** (See table below)

**Interfaces:** EIA RS-232, CCITT V.24

**Data Rates:** 50 - 115.2 Kbps

**Isolation:** Minimum 1500 V RMS via custom transformers

**Surge Protection:** 600W power dissipation at 1 mS;  
component response time of 1 pS; installed response time of 2 μs

**Dimensions:** 2.66" x 2.10" x 0.73"

**Factory Switch Setting:** DCE (transmits from RS-232 on pin 3)

**Control Signals:** DSR and DCD follow DTR from the terminal (DTE); CTS follows RTS from the terminal (DTE)

**Connectors:** DB-25 male or female on RS-232 side;  
RJ-11, RJ-45 or terminal block with strain relief on line side

**Power Supply:** None required; uses power from EIA data and control signals

**Temperature Range:** 0-60°C (32-140°F)

**Altitude:** 0-15,000 feet

**Humidity:** Up to 95% non-condensing

**Weight:** 2 oz.

Model 1010A Distance Table (miles)			
Data Rate	Wire Gauge		
	19	24	26
115,200	0.6	0.45	0.3
57,600	2.0	1.5	1.0
38,400	2.4	1.8	1.2
19,200	2.6	2.0	1.2
9,600	4.0	2.5	1.6
4,800	5.0	3.5	2.2
2,400	6.8	4.7	3.2
1,200	8.5	5.7	3.8

## 3.0 CONFIGURATION

The Model 1010A is designed to be easy to use. There are no internal jumpers or DIP switches to set, so there is no need to open the case to configure the unit (you may need to open the case for wire connection—refer to section 4.0). The only configuration necessary for operation is proper setting of the external DCE/DTE switch.

The figure below shows the location of the DCE/DTE switch on the PC board, as well as the location of the terminal block and surge suppressors.

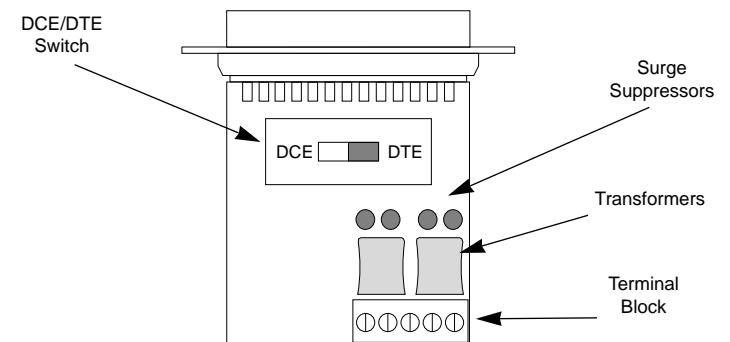

### 3.1 SETTING THE DTE/DCE SWITCH

For your convenience, the Model 1010A has an externally accessible DCE/DTE switch (see figure below). If the device connected to the Model 1010A is a modem or multiplexer (or is wired like one), set the switch to "DTE". This setting causes the Model 1010A to behave like Data Terminal Equipment and transmit data on pin 2.

If the device connected to the Model 1010A is a PC, terminal or host computer (or is wired like one), set the switch to "DCE". This setting causes the Model 1010A to behave like Data Communications Equipment and transmit data on pin 3.

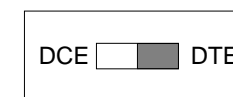

## 4.0 INSTALLATION

Once you have properly configured the DTE/DCE switch, you are ready to connect the Model 1010A to your system. This section tells you how to properly connect the Model 1010A to the twisted pair and RS-232 interfaces, and how to operate the Model 1010A.

### 4.1 CONNECTION TO THE TWISTED PAIR INTERFACE

The Model 1010A supports data-only communication between two RS-232 devices at distances to 8.5 miles and data rates to 115.2 Kbps. There are two essential requirements for installing the Model 1010A:

1) These units work in **pairs**. Therefore, you must have one Model 1010A at each end of a two twisted pair interface.

2) To function properly, the Model 1010A needs two twisted pairs of metallic wire. These pairs must be **unconditioned**, dry metallic wire, between 19 and 26 AWG (the higher number gauges may limit distance somewhat). Standard dial-up telephone circuits, or leased circuits that run through signal equalization equipment, are *not acceptable*.

For your convenience, the Model 1010A is available with three different twisted pair interfaces: RJ-11 jack, RJ-45 jack and terminal blocks with strain relief.

#### 4.1.1 TWISTED PAIR CONNECTION USING RJ-11 OR RJ-45

The RJ-11 and RJ-45 connectors on the Model 1010A's twisted pair interface are pre-wired for a standard TELCO wiring environment. The signal/pin relationships are shown below:

<u>RJ-11</u>	<u>SIGNAL</u>	<u>RJ-45</u>	<u>SIGNAL</u>
1.....	GND*	1 .....	N/C
2.....	RCV-	2 .....	GND*
3.....	XMT+	3 .....	RCV-
4.....	XMT-	4 .....	XMT+
5.....	RCV+	5 .....	XMT-
6.....	GND	6 .....	RCV+
		7 .....	GND
		8 .....	N/C

10. BEND the top half of the case as necessary to place it over the strain relief assembly. Do not snap the case together yet.

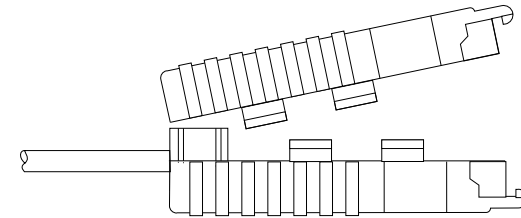

11. Insert one captive screw through a saddle washer, then insert the captive screw with the washer on it through the hole in the DB-25 end of the case. Snap that side of the case closed. Repeat the process for the other side. This completes cable installation.

### 4.2 CONNECTION TO THE RS-232 INTERFACE

Once you have configured the Model 1010A for DTE or DCE and connected the twisted pair wires correctly, all that remains is to plug the 1010A directly into the DB-25 port of the RS-232 device. After doing so, remember to insert and tighten the two captive connector screws.

(Note: If you must use a cable to connect the Model 1010A to the RS-232 device, make sure it is a *straight through* cable of the shortest possible length—we recommend 6 feet or less).

### 4.3 OPERATING THE MODEL 1010A

Once the Model 1010A is properly installed, it should operate transparently—as if it were a standard cable connection. Operating power is derived from the RS-232 data and control signals; there is no "ON/OFF" switch. All data signals from the RS-232 interface are passed straight through. All control signals from the RS-232 interface are looped back.

(Note: If your system requires *hardware* flow control, you will need the Patton Model 1012 or Model 1060 Short Range Modem. Call Patton Customer Service at 301-975-1007 for more information).

8. Place the 2 halves of the strain relief assembly on either side of the telephone wire and press together very lightly. Slide the assembly so that it is about 2 inches from the terminal posts and press together firmly. If your cable diameter is too small or too large for our strain relief, please contact our technical support. We have strain relief assemblies to accommodate most cable diameters.

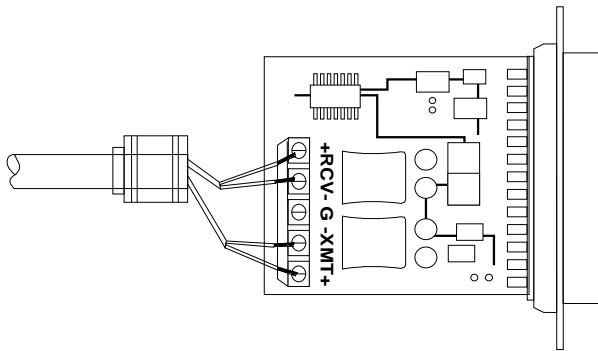

9. Insert the strain relief assembly with the wire going through it into the slot in the bottom half of the modem case and set it into the recess in the case.

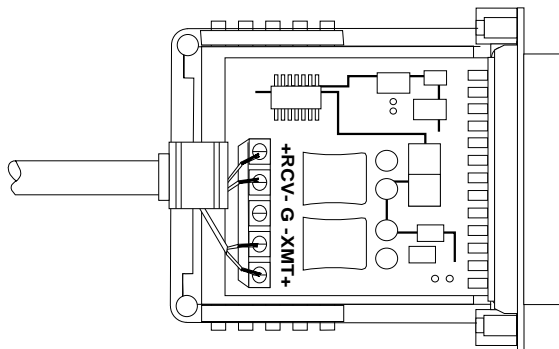

When connecting two Model 1010As, it is necessary to use a "cross over" cable. The diagram below shows how a cross over cable should be constructed for an environment where both Model 1010As use a 6-wire RJ-11 connector. Similar logic should be followed when using RJ-45 connectors or a combination of the two.

**RJ-11 Cable (4-Wire)**

<u>SIGNAL</u>	<u>PIN#</u>	<u>PIN#</u>	<u>SIGNAL</u>
GND†	1-----	6	GND†
RCV-	2-----	4	XMT-
XMT+	3-----	5	RCV+
XMT-	4-----	2	RCV-
RCV+	5-----	3	XMT+
GND†	6-----	1	GND†

†Connection to ground is optional

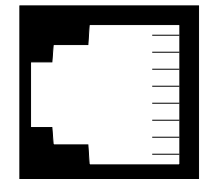
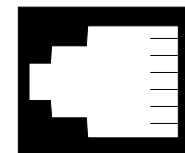

**4.1.2 TWISTED PAIR CONNECTION USING TERMINAL BLOCKS**

If your RS-422 application requires you to connect two pairs of bare wires to the Model 1010A, you will need to open the case to access the terminal blocks. The following instructions will tell you how to open the case, connect the bare wires to the terminal blocks, and fasten the strain relief collar in place so that the wires won't pull loose.

(continued)

1. Open the unit by gently inserting a screw driver between the DB-25 connector and the lip of the plastic case (see below). You don't have to worry about breaking the plastic, but be careful not to bend the D-sub connector.

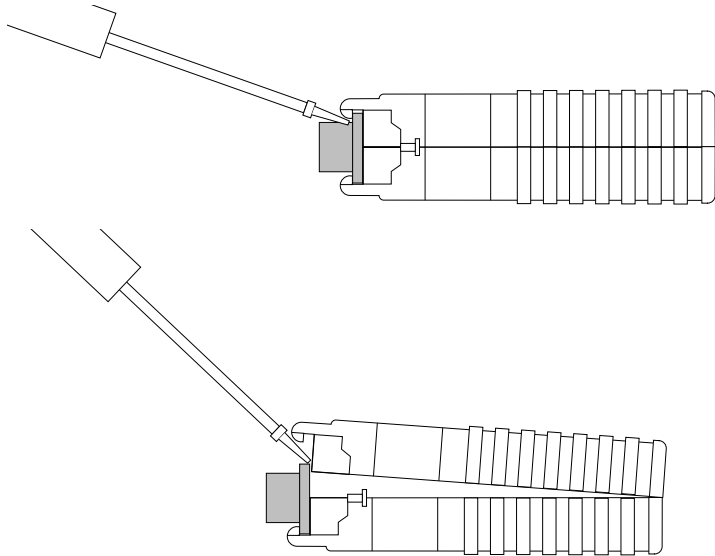

Once the unit has been opened, you will be able to see the terminal blocks located at the rear of the PC board.

2. Strip the outer insulation from the twisted pairs about one inch from the end.

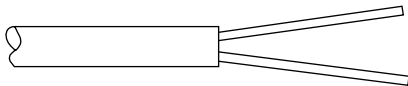

3. Strip back the insulation on each of the 2 twisted pair wires about .25".

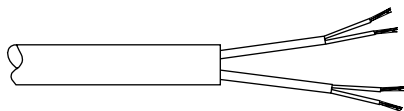

4. Connect *one pair* of wires to XMT+ and XMT- (transmit positive and negative) on the terminal block, making careful note of which color is positive, and which color is negative.

5. Connect the *other pair* of wires to RCV+ and RCV- (receive positive and negative) on the terminal block, again making careful note of which color is positive, and which color is negative.

Ultimately, you will want to construct a two pair cross over cable that makes a connection with the RS-422 device as shown below:

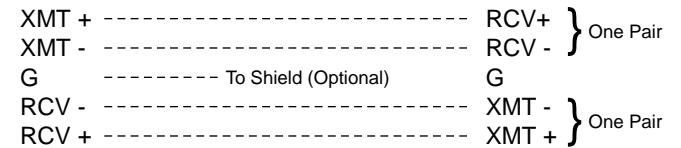

6. If there is a shield around the telephone cable, it may be connected to "G" on the terminal block. To avoid ground loops, we recommend connecting the shield at the computer end only. A ground wire is *not necessary* for proper operation of the Model 1010A.

7. When you finish connecting the wires to the terminal block, the assembly should resemble the diagram below:

