

DMD15/DMD15L

IBS/IDR Universal Satellite Modem

Installation and Operation Manual

TM051 - Rev. 5.8

- NOTICE -

©2005, Radyne, Inc. This manual may not in whole or in part be copied, reproduced, translated or reduced to any electronic or magnetic storage medium without the written consent of a duly authorized officer of Radyne, Inc.





Latest Software Revision Confirmation

When new features are added to Radyne, Inc. equipment, the control parameters are appended to the end of the Non-Volatile Section of the Remote Communications Specification, and status of the features, if any, are added at the end of the Volatile Section. If a remote M&C queries two pieces of Radyne, Inc. equipment with different revision software, they could respond with two different sized packets. The remote M&C **MUST** make use of the non-volatile count value to index to the start of the Volatile Section. If the remote M&C is not aware of the newly added features to the product, it should disregard the parameters at the end of the Non-Volatile Section and index to the start of the Volatile Section.

Before creating any software based on the information contained in this document, contact the Radyne, Inc. Customer Service Department at (602) 437-9620 to find out if the software revision for that piece of equipment is current and that no new features have been added since the release of this document.



Radyne, Inc. Warranty Policy

Warranty and Service

Radyne, Inc. (Seller) warrants the items manufactured and sold by Radyne, Inc. to be free of defects in material and workmanship for a period of two (2) years from date of shipment. Radyne, Inc.'s obligation under its warranty is limited in accordance with the periods of time and all other conditions stated in all provisions of this warranty.

This warranty applies only to defects in material and workmanship in products manufactured by Radyne, Inc. Radyne, Inc. makes no warranty whatsoever concerning products or accessories not of its manufacture. Repair, or at Radyne, Inc.'s option, replacement of the Radyne, Inc. products or defective parts therein shall be the sole and exclusive remedy for all valid warranty claims.

Warranty Period

The applicable warranty period shall commence on the date of shipment from Radyne, Inc.'s facility to the original purchaser and extend for the stated period following the date of shipment. Upon beginning of the applicable Radyne, Inc. warranty period, all customer's remedies shall be governed by the terms stated or referenced in this warranty. In-warranty repaired or replacement products or parts are warranted only for the remaining unexpired portion of the original warranty period applicable to the repaired or replaced products or parts. Repair or replacement of products or parts under warranty does not extend the original warranty period.

Warranty Coverage Limitations

The following are expressly **not covered** under warranty:

- 5 Any loss, damage and/or malfunction relating in any way to shipping, storage, accident, abuse, alteration, misuse, neglect, failure to use products under normal operating conditions, failure to use products according to any operating instructions provided by Radyne, Inc., lack of routine care and maintenance as indicated in any operating maintenance instructions, or failure to use or take any proper precautions under the circumstances.
- 5 Products, items, parts, accessories, subassemblies, or components which are expendable in normal use or are of limited life, such as but not limited to, bulbs, fuses, lamps, glassware, etc. Radyne, Inc. reserves the right to revise the foregoing list of what is covered under this warranty.

Warranty Replacement and Adjustment

Radyne, Inc. will not make warranty adjustments for failures of products or parts, which occur after the specified maximum adjustment period. Unless otherwise agreed, failure shall be deemed to have occurred no more than seven (7) working days before the first date on which a notice of failure is received by Radyne, Inc. Under no circumstances shall any warranty exceed the period stated above unless expressly agreed to in writing by Radyne, Inc.

Liability Limitations

This warranty is expressly in lieu of and excludes all other express and implied warranties, including but not limited to warranties of merchantability and of fitness for particular purpose, use, or applications, and all other obligations or liabilities on the part of Radyne Inc., unless such other warranties, obligations, or liabilities are expressly agreed to in writing by Radyne, Inc.

All obligations of Radyne, Inc. under this warranty shall cease in the event its products or parts thereof have been subjected to accident, abuse, alteration, misuse or neglect, or which have not been operated and maintained in accordance with proper operating instructions. In no event shall Radyne, Inc. be liable for incidental, consequential, special or resulting loss or damage of any kind howsoever caused.

Radyne, Inc.'s liability for damages shall not exceed the payment, if any, received by Radyne, Inc. for the unit or product or service furnished or to be furnished, as the case may be, which is the subject of claim or dispute.

Statements made by any person, including representatives of Radyne, Inc., which are inconsistent or in conflict with the terms of this warranty, shall not be binding upon Radyne, Inc. unless reduced to writing and approved by an officer of Radyne, Inc.

Warranty Repair Return Procedure

Before a warranty repair can be accomplished, a Repair Authorization must be received. It is at this time that Radyne, Inc. will authorize the product or part to be returned to the Radyne, Inc. facility or if field repair will be accomplished. The Repair Authorization may be requested in writing or by calling:

Radyne, Inc.

3138 E. Elwood St.
Phoenix, Arizona 85034 (USA)
ATTN: Customer Support
Phone: (602) 437-9620
Fax: (602) 437-4811

Any product returned to Radyne, Inc. for examination must be sent prepaid via the means of transportation indicated as acceptable to Radyne, Inc. Return Authorization Number must be clearly marked on the shipping label. Returned products or parts should be carefully packaged in the original container, if possible, and unless otherwise indicated, shipped to the above address.

Non-Warranty Repair

When a product is returned for any reason, Customer and its shipping agency shall be responsible for all damage resulting from improper packing and handling, and for loss in transit, notwithstanding any defect or nonconformity in the product. By returning a product, the owner grants Radyne, Inc. permission to open and disassemble the product as required for evaluation. In all cases, Radyne, Inc. has sole responsibility for determining the cause and nature of failure, and Radyne, Inc.'s determination with regard thereto shall be final.

DMD15/DMD15L IBS/IDR Universal Satellite Installation and Operation Manual TM051 – Record of Revisions

Radyne, Inc. is constantly improving its products and therefore the information in this document is subject to change without prior notice. Radyne, Inc. makes no warranty of any kind with regard to this material, including but not limited to the implied warranties of merchantability and fitness for a particular purpose. No responsibility for any errors or omissions that may pertain to the material herein is assumed. Radyne, Inc. makes no commitment to update nor to keep current the information contained in this document. Radyne, Inc. assumes no responsibility for use of any circuitry other than the circuitry employed in Radyne, Inc. systems and equipment.

Revision Level	Date	Reason for Change
1.0	6-18-96	Initial Release.
2.0	9-1-96	Expanded Drop and Insert Section, updated menu trees and descriptions, added Strap Code Table, updated Fault Menus, added UIO Interface Settings, updated Specifications Section.
2.1	9-16-96	Added DMD15/DMD15L Terminal Screens (Appendix C), added Modem Loopback Figures, expanded Principles of Operation Section, added IBS Conditions and Faults Table, added new Universal Interface Illustrations and pinout tables.
2.2	11-25-96	Expanded Drop and Insert Data and figures, added BER Curves, added additional Interface Pinout Tables and descriptions.
3.0	12-16-96	Added Reed-Solomon Menu Tree enhancements, added Clocking Data Definitions, minor rearrangements and clarifications.
3.1	4-10-97	Added additional Reed-Solomon Data, additional UIM Data, and minor corrections to pinout tables.
4.0	8-1-99	Added AUPC data, new Menu Screens, L-Band Data, ESC Audio Data and minor corrections
4.1	7-31-00	Added AGC Output Data on Table 2-5.
5.0	12-14-01	Revised and reformatted entire Technical Manual.
5.1	1-30-02	Removed Ethernet Port section.
5.2	3-5-02	Revised Sections 4.3.2, Mod Data (menu), and 4.3.3, Demod Data (menu).
5.3	6-11-02	Revised Section 1.1.12.
5.4	8-22-02	Revised Sections 7.0 and 7.1.
5.5	8-26-02	Added Modem Status pinouts to Section 5.0.
5.6	9-17-03	Updated user interface, added reacquisition description, updated RLLP.
5.7	7-30-04	Revised RLLP.
5.8	10-15-05	Revised Sections 4.0 & 5.0



Table of Contents

Section 1 – Introduction

1.0 Description _____	1-1
1.1 DMD15/DMD15L Available Options _____	1-1
1.1.1 Internal High Stability _____	1-1
1.1.2 Reed-Solomon Codec _____	1-1
1.1.3 Turbo Codec _____	1-2
1.1.4 Drop and Insert (D&I) _____	1-2
1.1.5 8PSK Modulation _____	1-2
1.1.6 OQPSK Modulation _____	1-2
1.1.7 16QAM Modulation _____	1-2
1.1.8 Sequential Decoding _____	1-2
1.1.9 Earth Station-to-Earth Station (ES-ES) Communications _____	1-2
1.1.10 Analog AGC Voltage _____	1-2
1.1.11 Internal Engineering Service Channel (ESC) _____	1-2
1.1.12 OM73 Compatible _____	1-2
1.1.13 Back Panel Options _____	1-3
1.1.14 Customized Options _____	1-3

Section 2 – Installation

2.0 Installation Requirements _____	2-1
2.1 Unpacking _____	2-1
2.2 Removal and Assembly _____	2-1
2.3 Mounting Considerations _____	2-2
2.4 DMD15/DMD15L Initial Configuration Check _____	2-2
2.5 Modulator Checkout _____	2-3
2.5.1 Initial Power-Up _____	2-3

Section 3 – Operation

3.0 Theory of Operation _____	3-1
3.1 DMD15/DMD15L Functional Block Diagram _____	3-1
3.2 Universal Interface Module (UIM) _____	3-3
3.3 Synchronous Interface _____	3-4
3.4 G.703 Interface _____	3-4
3.5 Earth Station to Earth Station (ES-ES) Communications Port _____ (Async Port J9) _____	3-5
3.6 Terrestrial Loopback _____	3-5
3.7 Modem Status _____	3-5
3.8 Baseband Processor Card _____	3-8
3.8.1 Baseband Processing _____	3-8
3.8.2 Tx Baseband Processing _____	3-8
3.8.3 Rx Baseband Processing _____	3-9
3.8.4 Clock Selection _____	3-9
3.9 Monitor & Control (M&C) Subsystem _____	3-9
3.9.1 Asynchronous Serial Port #1 _____	3-9
3.9.2 Serial Port #2 _____	3-9
3.9.3 Serial Port #3 _____	3-9
3.9.4 Front Panel Interface _____	3-10
3.9.5 Clock _____	3-10
3.9.6 Watchdog Timer _____	3-10
3.9.7 Program Flash ROM _____	3-10
3.9.8 RAM _____	3-10
3.9.9 Non-Volatile RAM _____	3-10
3.10 Universal Modem _____	3-10
3.10.1 Modulator _____	3-10
3.10.2 Demodulator _____	3-11
3.11 DMD15/DMD15L Clocking Options _____	3-11
3.11.1 SCTE: Serial Clock Transmit External _____	3-11
3.11.2 SCT: Serial Clock Transmit _____	3-11
3.11.4 EXT EXC: External Clock _____	3-11
3.11.5 BNC EXC: BNC External Clock _____	3-11
3.11.6 BAL EXC: Balanced External Clock _____	3-11
3.11.7 IDI: Insert Data In _____	3-12

3.11.8 SCR: Serial Clock Receive _____	3-12
3.11.9 EXT IF REF: External IF Reference _____	3-12
3.12 Transmit Timing _____	3-12
3.12.1 EXT CLK as TX Clock Source (RS-422 or V.35 Interface) _____	3-12
3.12.2 SCT or SCTE _____	3-12
3.12.3 G.703 Interface _____	3-12
3.13 Receive Timing _____	3-12
3.14 Loop Timing _____	3-13
3.14.1 Transmit (RS-422 or V.35 Interface) _____	3-13
3.14.2 G.703 Interface or Asymmetrical Data Rates _____	3-13
3.14.3 Receive _____	3-13
3.15 Drop and Insert (D&I) _____	3-13
3.15.1 Drop Only _____	3-15
3.15.2 Insert Only _____	3-15
3.16 Mode Selection _____	3-16
3.16.1 PCM-30 _____	3-16
3.16.2 PCM-30C _____	3-16
3.16.3 PCM-31 _____	3-16
3.16.4 PCM-31C _____	3-17
3.16.5 T1-D4/T1-D4-S _____	3-17
3.16.6 T1-ESF/ T1-ESF-S _____	3-17
3.16.7 SLC-96 _____	3-17
3.17 Multidestinational Systems _____	3-17
3.17 Drop and Insert Mapping _____	3-18
3.18 Reed-Solomon Codec (Refer to Figures 3-14, 3-15, and Table 3-1) _____	3-20
3.18.1 Operation in the DMD15/DMD15L _____	3-20
3.18.2 Reed-Solomon Code Rate _____	3-20
3.18.3 Interleaving _____	3-20
3.19 DMD15 Automatic Uplink Power Control (AUPC Operation) _____	3-22
3.20 DMD15 Asynchronous Overhead Operation _____	3-24
3.20.1 Asynchronous Framing/Multiplexer Capability _____	3-24
3.21 Standard IBS Mode _____	3-26
3.22 Asynchronous Multiplexer Mode _____	3-26
3.23 ESC Backward Alarms _____	3-26
3.23.1 To Disable the ESC Backward Alarms _____	3-27

3.24	Reacquisition	3-27
------	---------------	------

Section 4 – User Interfaces

4.0	User Interfaces	4-1
4.1	Front Panel User Interface	4-1
4.1.1	LCD Front Panel Display	4-2
4.1.2	Cursor Control Arrow Keys	4-2
4.1.3	Numeric Keypad	4-2
4.1.4	Front Panel LED Indicators	4-3
4.2	Parameter Setup	4-3
4.3	Front Panel Control Screen Menus	4-4
4.3.1	Main Menu	4-4
4.3.2	Modulator Menu Options and Parameters	4-4
4.3.3	Demodulator Menu Options and Parameters	4-8
4.3.4	Interface Menu Options and Parameters	4-11
4.3.5	AUPC Menu Options and Parameters	4-14
4.3.6	Monitor Menu Options and Parameters	4-16
4.3.7	Alarms Menu Options and Parameters	4-17
4.3.8	System Menu Options and Parameters	4-24
4.3.9	Test Menu Options and Parameters	4-25
4.4	DMD15/DMD15L Strap Codes	4-26
4.5	Sample DMD15/DMD15L Applications	4-30
4.5.1	Operational Case Examples	4-31
4.6	Configuring the DMD15/DMD15L for Drop and Insert	4-34
4.6.1	Data Rate	4-34
4.6.2	Operational Mode	4-35
4.6.3	Terrestrial Framing - Drop Mode/Insert Mode	4-35
4.6.3.1	Insert Terrestrial Frame Source	4-35
4.6.4	D&I Sample Configurations and D&I Clock Setup Options	4-36
4.7	D&I Maps and Map Editing	4-40
4.8	Terminal Mode Control	4-43
4.8.1	Modem Terminal Mode Control	4-43
4.8.2	Modem Setup for Terminal Mode	4-43

Section 5 – Electrical Interfaces

5.0 DMD15/DMD15L Connections	5-1
5.1 Power Inputs	5-2
5.1.1 AC Power Input Module	5-2
5.1.2 DC Power Input Module	5-2
5.2 TX (J1)	5-3
5.3 RX (J2)	5-3
5.4 SD (J3)	5-3
5.5 DDO (J4)	5-3
5.6 IDI EXC (J5)	5-3
5.7 EXT CLK (J5) – Synchronous Interface Only	5-3
5.8 RD (J6)	5-3
5.9 G.703 (J7)	5-3
5.10 SYNC DATA (J8)	5-4
5.11 ASYNC (J9)	5-5
5.11 STATUS (J11)	5-6
5.13 TERMINAL (J12)	5-7
5.14 REMOTE (J13)	5-7
5.15 ESC 8K DATA (J15)	5-8
5.16 ESC VOICE (J16)	5-9
5.17 ESC ALARMS (J17)	5-9
5.18 SWITCH (J18)	5-10

Section 6 – Maintenance

6.0 Periodic Maintenance	6-1
6.1 Troubleshooting	6-1
6.2 DMD15/DMD15L Fault Philosophy	6-1
6.2.1 Alarm Masks	6-2
6.2.2 Active Alarms	6-2
6.2.2.1 Major Alarms	6-2
6.2.2.2 Minor Alarms	6-2
6.2.2.3 Latched Alarms	6-2
6.3 DMD15/DMD15L Fault Tree Matrices	6-2
6.3.1 Interpreting the Matrices	6-4
6.3.2 IBS Fault Conditions and Actions	6-4

Section 7 – Technical Specifications

7.0 Modulator Specifications _____	7-1
7.1 Demodulator Specifications _____	7-1
7.2 Plesiochronous Buffer _____	7-2
7.3 Monitor and Control _____	7-2
7.4 DMD15/DMD15L Drop and Insert (Optional) _____	7-2
7.5 Terrestrial Interfaces _____	7-3
7.6 Universal Interface _____	7-3
7.7 Environmental _____	7-3
7.8 Physical _____	7-3
7.9 DMD15 Data Rate Limits _____	7-4
7.10 DMD15 BER Specifications _____	7-5

Section 8 – Appendices

Appendix A – Reed-Solomon Codes _____	A-1
---------------------------------------	-----

Glossary _____	G-1
-----------------------	------------

Section 1 – Introduction

1.0 Description

The Radyn, Inc. DMD15/DMD15L Satellite Modem (Figure 1-1) offers the best features of a sophisticated programmable IBS/IDR and Closed Network Modem, at an affordable price.

This versatile equipment package combines unsurpassed performance with numerous user-friendly Front Panel Programmable Functions. The DMD15/DMD15L provides selectable functions for different services: Intelsat IDR and IBS, as well as closed networks. All of the configuration and Monitor and Control (M&C) Functions are available at the Front Panel. Operating parameters, such as variable data rates, FEC Code Rate, modulation type, IF frequencies, IBS/IDR Framing and interface type can be readily set and changed at the Front Panel by earth station operations personnel. Additionally, all functions can be accessed with a terminal or personal computer via a serial link for complete remote monitoring and control capability.

The DMD15/DMD15L operates at all standard IBS and IDR Data Rates up to 8.448 Mbps. Selection of any data rate is provided over the range of 9.6 Kbps to 10 Mbps in 1 bps steps.

For applications requiring system redundancy, the DMD15/DMD15L Modem may be used with the Radyne, Inc. RCS11 1:1 Redundancy Switch or the RCS20 M:N (N < 9) Redundancy Switch. An optional Internal Engineering Service Channel Unit is available to provide voice, data, and alarms for Intelsat IDR applications.

A full range of Industry Standard Interfaces is available for the DMD15/DMD15L. Interface types are selectable from V.35, RS-232, RS-422/449 and ITU G.703.

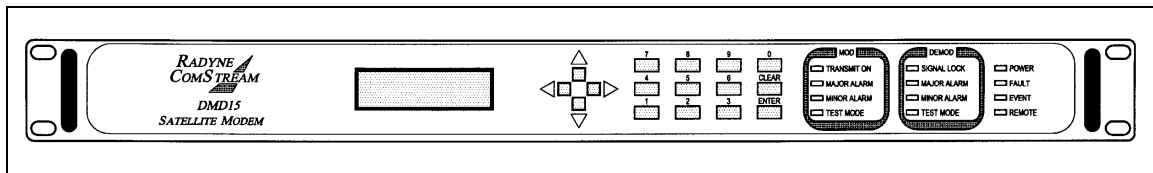

Figure 1-1. DMD15/DMD15L Universal Satellite Modem Front Panel

1.1 DMD15/DMD15L Available Options

A wide range of options is available for the DMD15/DMD15L Satellite Modem.

1.1.1 Internal High Stability

The DMD15/DMD15L can be equipped with a 1×10^{-7} or better Stability Frequency Reference as an add-on enhancement.

1.1.2 Reed-Solomon Codec

The DMD15/DMD15L can be equipped with a Reed-Solomon (R-S) Outer Codec with an interleaver as an optional add-on enhancement. The encoder and decoder are completely independent and meet the IESS-308/309/310 specification. Once prepped, this option can be installed in the field by installing five ICs into existing sockets. The DMD15/DMD15L must be prepped for this option.

Note: Custom Reed-Solomon codes are also available.

1.1.3 Turbo Codec

The DMD15/DMD15L can be equipped with an optional Turbo Codec Outer Code. This option must be installed at the factory.

1.1.4 Drop and Insert (D&I)

The DMD15/DMD15L can be equipped with a D&I Interface as an add-on enhancement. This option can be added in the field by installing one IC into an existing socket. The D&I Functions are completely independent and can be programmed for n x 64 blocks for either a T1 or E1 Data Stream.

1.1.5 8PSK Modulation

The DMD15/DMD15L can be equipped with 8PSK Modulation/Demodulation capability as an add-on option. The 8PSK Option can be added by installing 2 ICs into existing sockets.

1.1.6 OQPSK Modulation

The DMD15/DMD15L can be equipped with an OQPSK modulation/demodulation capability as an add-on option. The option can be added in the field by installing one IC into an existing socket.

1.1.7 16QAM Modulation

The DMD15/DMD15L can be equipped with a 16QAM Modulation/Demodulation capability as an add-on option. The 16QAM option can be added by installing 2 ICs into existing sockets.

1.1.8 Sequential Decoding

The DMD15/DMD15L can be equipped with a sequential decoding option that can be installed as an add-on option. The DMD15/DMD15L must be prepped for this option in the factory. Once prepped, the option can be added by installing 3 ICs into existing sockets. Sequential Encoding/Decoding can operate with 1/2, 3/4, and 7/8 Rates, up to data rates of 2.048 Mbps.

1.1.9 Earth Station-to-Earth Station (ES-ES) Communications

The DMD15/DMD15L can be equipped with an asynchronous overhead channel capability as an add-on option. The option can be added in the field by installing 2 ICs into existing sockets. The overhead channel is proportional to the data rate (2,400 baud per 64 KB) up to a maximum of 19.2 Kbaud.

1.1.10 Analog AGC Voltage

The DMD15/DMD15L can be equipped at the factory to produce an analog voltage equivalent to its AGC for use in antenna controllers.

1.1.11 Internal Engineering Service Channel (ESC)

The DMD15/DMD15L can be equipped with an internal ESC. This unit is a card on the Universal Interface Module (UIM). The DMD15/DMD15L can be updated with an ESC capable UIM in the field with no other changes required.

1.1.12 OM73 Compatible

The DMD15/DMD15L can be equipped with an optional OM73 scrambler at the customer's request. This option must be prepped at the factory. Once installed, selection of the OM73 Scrambler/Descrambler will automatically invert the baseband data on the Modulator/Demodulator respectively. This configuration is required to run compatible with the OM73 Modem.

1.1.13 Back Panel Options

The DMD15/DMD15L has several optional Interface Modules available (refer to Figures 5-1 through 5-5). These include:

- Universal Interface Module w/ ESC
- G.703 Interface Module w/ESC
- G.703 Interface Module
- Universal Interface Module
- Synchronous Interface Module

These Interface Modules are available with AC or DC Power Input Modules and the following Transmit and Receive schemes.

- IF Transmit and Receive
- L-Band Transmit and Receive
- IF Transmit, L-Band Receive
- IF Receive Only
- L-Band Receive Only

1.1.14 Customized Options

The DMD15/DMD15L may be customized for specific customer requirements. Most modifications or customization can be accomplished by means of firmware/software modifications. The following are examples of the types of customization available to the user:

- Customized Data Rates.
- Customized Scrambler/Descramblers.
- Customized Overhead Framing Structures.
- Customized Modulation Formats.
- Customized Uses for the Earth Station-to-Earth Station (ES-ES) Overhead Channel.

Contact the Radyne , Inc. Customer Service or Sales Department at (602) 437-9620 for all requests.

Section 2 – Installation

2.0 Installation Requirements

The DMD15/DMD15L Modem is designed to be installed within any standard 19-inch wide equipment cabinet or rack, and requires one rack unit (RU) of mounting space (1.75 inches) vertically and 21 inches of depth. Including cabling, a minimum of 23 inches of rack depth is required. The rear panel of the DMD15/DMD15L is designed to have power enter from the right and IF Cabling enter from the left when viewed from the rear of the modem. Data and control cabling can enter from either side although they are closer to the right. The unit can be placed on a table or suitable surface if required.



There are no user-serviceable parts or configuration settings located inside the DMD15/DMD15L Chassis. There is a potential shock hazard internally at the power supply module. DO NOT open the DMD15/DMD15L Chassis under any circumstances.



Before initially applying power to the unit, it is a good idea to disconnect the transmit output from the operating ground station equipment. This is especially true if the current DMD15/DMD15L configuration settings are unknown, where incorrect settings could disrupt existing communications traffic.

2.1 Unpacking

The DMD15/DMD15L Modem was carefully packaged to avoid damage and should arrive complete with the following items for proper installation:

1. DMD15/DMD15L Modem Unit.
2. Power Cord, 6-foot with applicable AC Connector.
3. Installation and Operation Manual.

2.2 Removal and Assembly

Carefully unpack the unit and ensure that all of the above items are in the carton. If the Prime AC power available at the installation site requires a different Power Cord/AC Connector, then arrangements to receive the proper device will be necessary before proceeding with the installation.

The DMD15/DMD15L Modem Unit is shipped fully assembled and does not require removal of the covers for any purpose in installation. The only replaceable assembly in the unit is the Universal Interface Module (UIM).



Always ensure that power is removed from the DMD15/DMD15L before removing or installing a UIM. Failure to do so may cause damage to the equipment.

Should the Power Cable/AC Connector be of the wrong type for the installation, either the cable or the power connector end should be replaced. The power supply itself is designed for universal application using from 100 to 240 VAC, 50 to 60 Hz, 1.0 A.

2.3 Mounting Considerations

When mounted in an equipment rack, adequate ventilation must be provided. The ambient temperature in the rack should preferably be between 10° and 35° C, and held constant for best equipment operation. The air available to the rack should be clean and relatively dry. The modem units may be stacked one on top of the other to a maximum of 10 consecutive units before providing one RU of space for airflow. Modem units should not be placed immediately above a high heat or EMF Generator to ensure the output signal integrity and proper receive operation.

Do not mount the DMD15/DMD15L in an unprotected outdoor location where there is direct contact with rain, snow, wind or sun. The modem is designed for indoor applications only. The only tools required for rack mounting the DMD15/DMD15L is a set of four rack-mounting screws and the appropriate screwdriver. Rack mounting brackets are an integral part of the cast front bezel of the unit and are not removable.

2.4 DMD15/DMD15L Initial Configuration Check

The DMD15/DMD15L is shipped from the factory with preset factory defaults. Upon initial power-up, a user check should be performed to verify the shipped modem configuration. Refer to Section 4, User Interfaces to locate and verify that the following configuration settings are correct:



The DMD15/DMD15L Interface Type (V.35, RS-422, RS-232, G.703, etc.) MUST be selected from the Front Panel BEFORE the mating connectors are installed. Failure to do so may cause damage to the Universal Interface Module. Power up the DMD15/DMD15L, select the appropriate interface type, and then install the mating connectors.

Note: *Transmit (Tx) and Receive (Rx) Interface types are dependent upon the customer's order.*

Standard DMD15/DMD15L Factory Configuration Settings

Modulator:

Data Rate:	2.048 Mbps
Mode:	Closed Network
Forward Error Correction:	1/2 Rate Viterbi
Modulation:	QPSK
Frequency:	70.000000 MHz

Note: *The above modem configuration can be set by implementing Strap Code 26. Refer to Table 3-1 for an explanation and tabular listing of available Strap Codes.*

Modulator Output Power: -20 dBm

Demodulator:

Data Rate:	2.048 Mbps
Mode:	Closed Network
Forward Error Correction:	1/2 Rate Viterbi
Frequency:	70.000000 MHz

To lock up the modem, enter 'IF Loopback Enable' under the Test menu, or connect a Loopback Cable from J1 to J2 on the rear panel of the modem.

2.5 Modulator Checkout

The following descriptions assume that the DMD15/DMD15L is installed in a suitable location with prime AC power and supporting equipment available.

2.5.1 Initial Power-Up



Before initial power up of the DMD15/DMD15L, it is a good idea to disconnect the transmit output from the operating ground station equipment. This is especially true if the current Modulator Configuration Settings are unknown, where incorrect settings could disrupt the existing communications traffic. New units from the factory are normally shipped in a default configuration which includes setting the transmit carrier off.

Turn on the unit by placing the Rear Panel Switch (located above the power entry connector) to the 'ON' position. Upon initial and subsequent power-ups, the DMD15/DMD15L Microprocessor will test itself and several of its components before beginning its Main Monitor/Control Program. These power-up diagnostics show no results if successful. If a failure is detected, the Fault LED will illuminate.

The initial field checkout of the modem can be accomplished from the Front Panel or in the Terminal Mode. The Terminal Mode has the advantage of providing full screen access to all of the modem's parameters, but requires a separate terminal or computer running a Terminal Program. The unit is placed into terminal mode by setting two options via the Front Panel. The two options are the Term Baud and Emulation settings found under the System M&C Submenus.

Terminal Setup:

Baud Rate:	19.2 K (Can be changed via Front Panel)
Data Bits:	8
Parity:	No Parity (Fixed)
Stop Bits:	1 Stop Bit

Section 3 – Operation

3.0 Theory of Operation

The DMD15/DMD15L is designed in three major sections: Universal Interface, Baseband Processing, and Universal Modem.

3.1 DMD15/DMD15L Functional Block Diagram

Figures 3-1a through 3-1c represent the DMD15/DMD15L Functional Blocks. The modem is shown in a typical application with customer data, Tx/Rx RF equipment and an antenna.

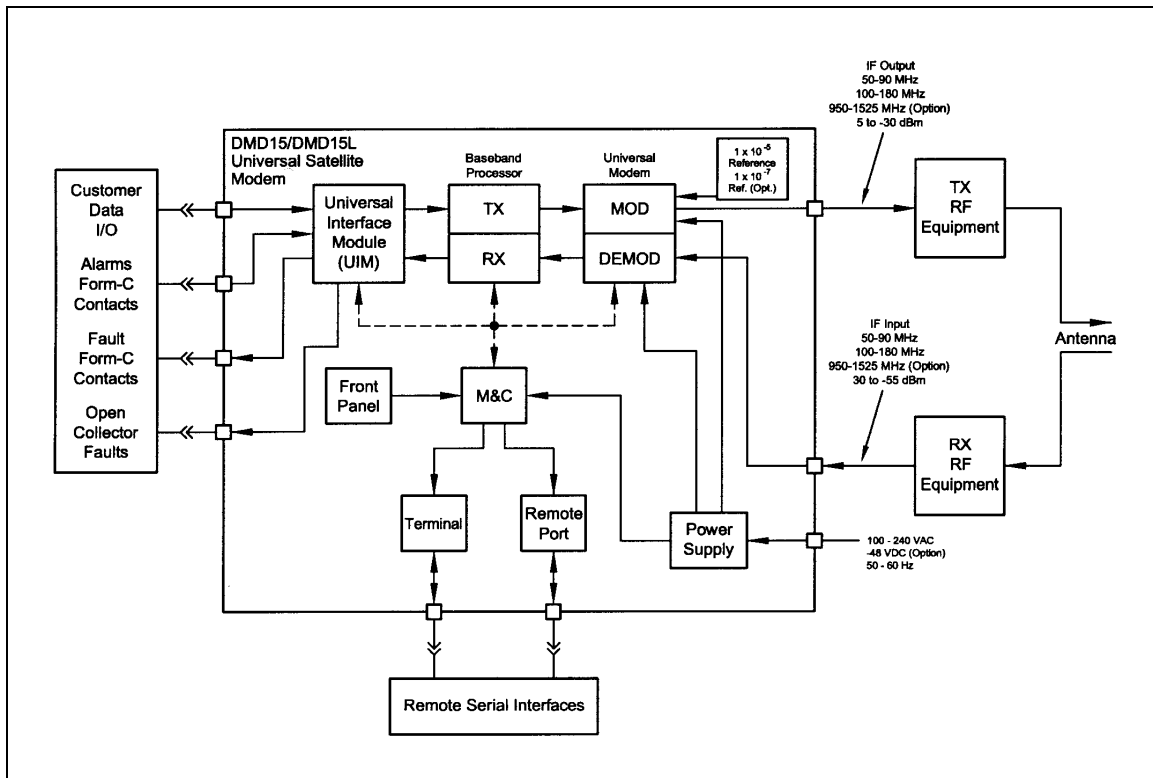

Figure 3-1a. DMD15/DMD15L Universal Satellite Modem Functional Block Diagram

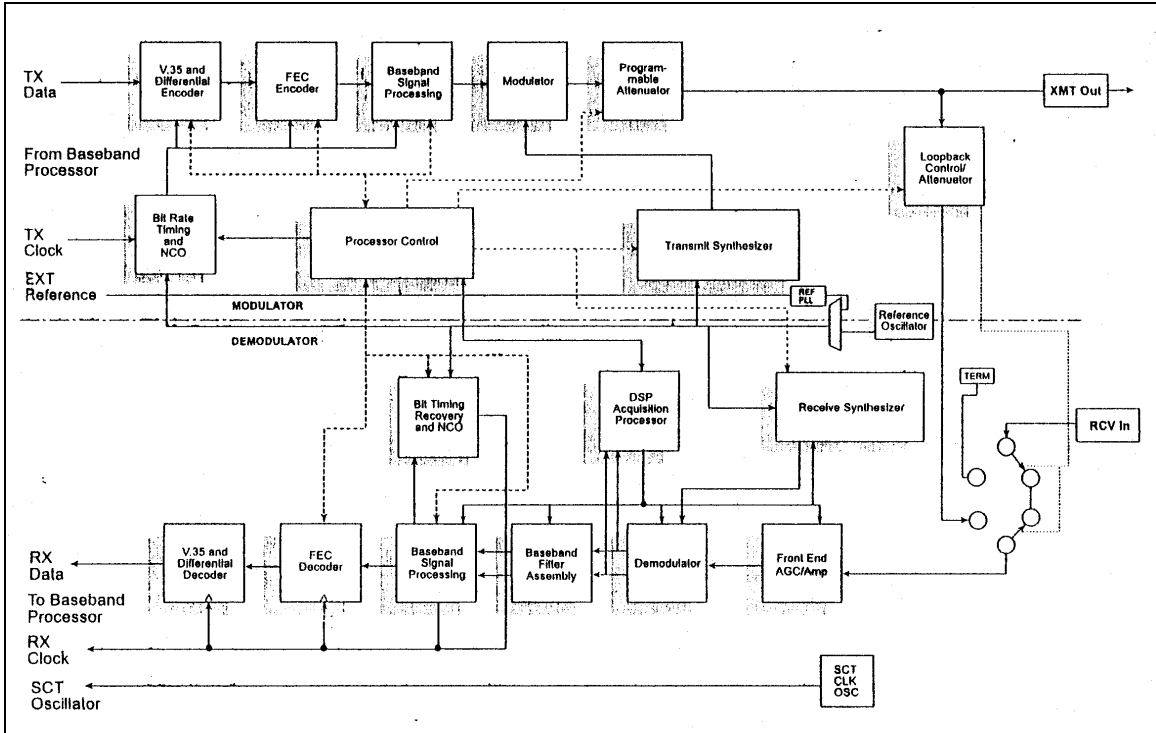

Figure 3-1b (Alternate 1). DMD15/DMD15L Universal Satellite Modem Functional Block Diagram

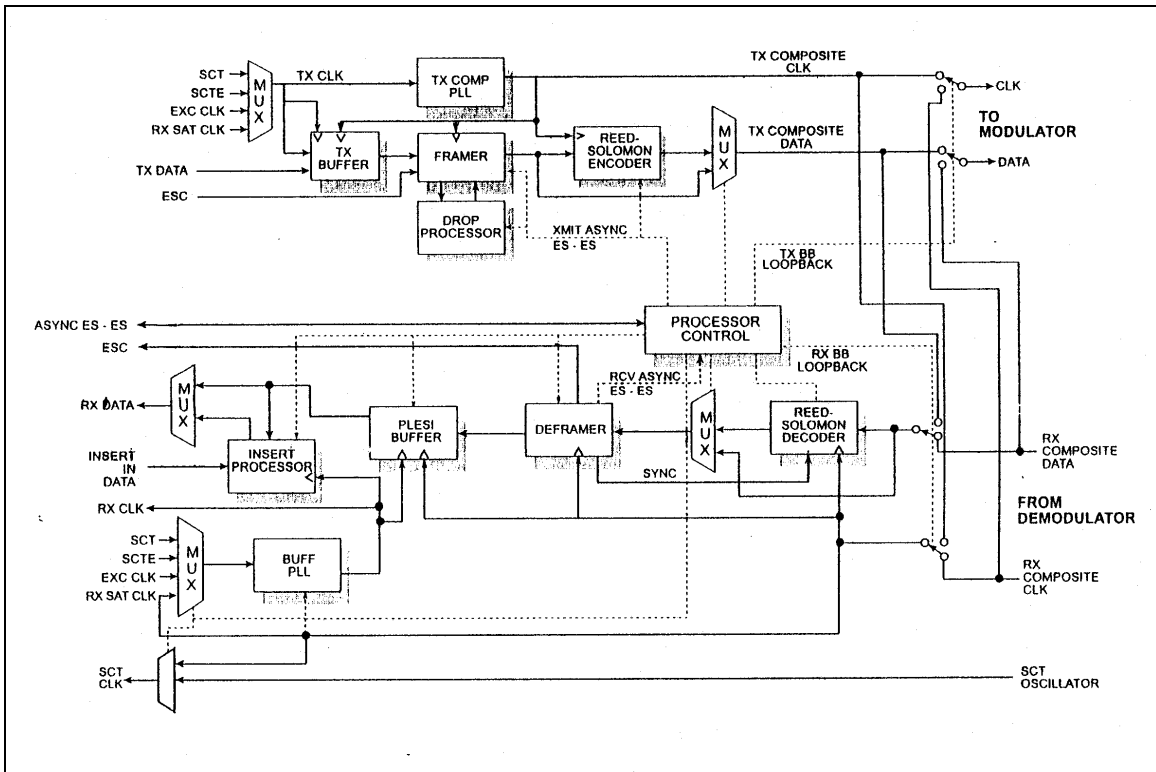

Figure 3-1c (Alternate 2). DMD15/DMD15L Universal Satellite Modem Functional Block Diagram

3.2 Universal Interface Module (UIM)

The Universal Interface Module (UIM) is a field-replaceable module that plugs into the rear of the DMD15/DMD15L. The UIM provides the interconnection points (J3 - J8) for Terrestrial Data and Clock to the Modem. The UIM also contains a Connection Port for an Asynchronous Data Channel (J9) for use in Earth Station-to-Earth Station (ES-ES) communications. Additionally, the UIM provides connection points (J11) for Form-C modem Status Relays. An illustration of two versions of the UIM is shown in Figure 3-2, and Functional Block Diagrams are shown in Figure 3-3.

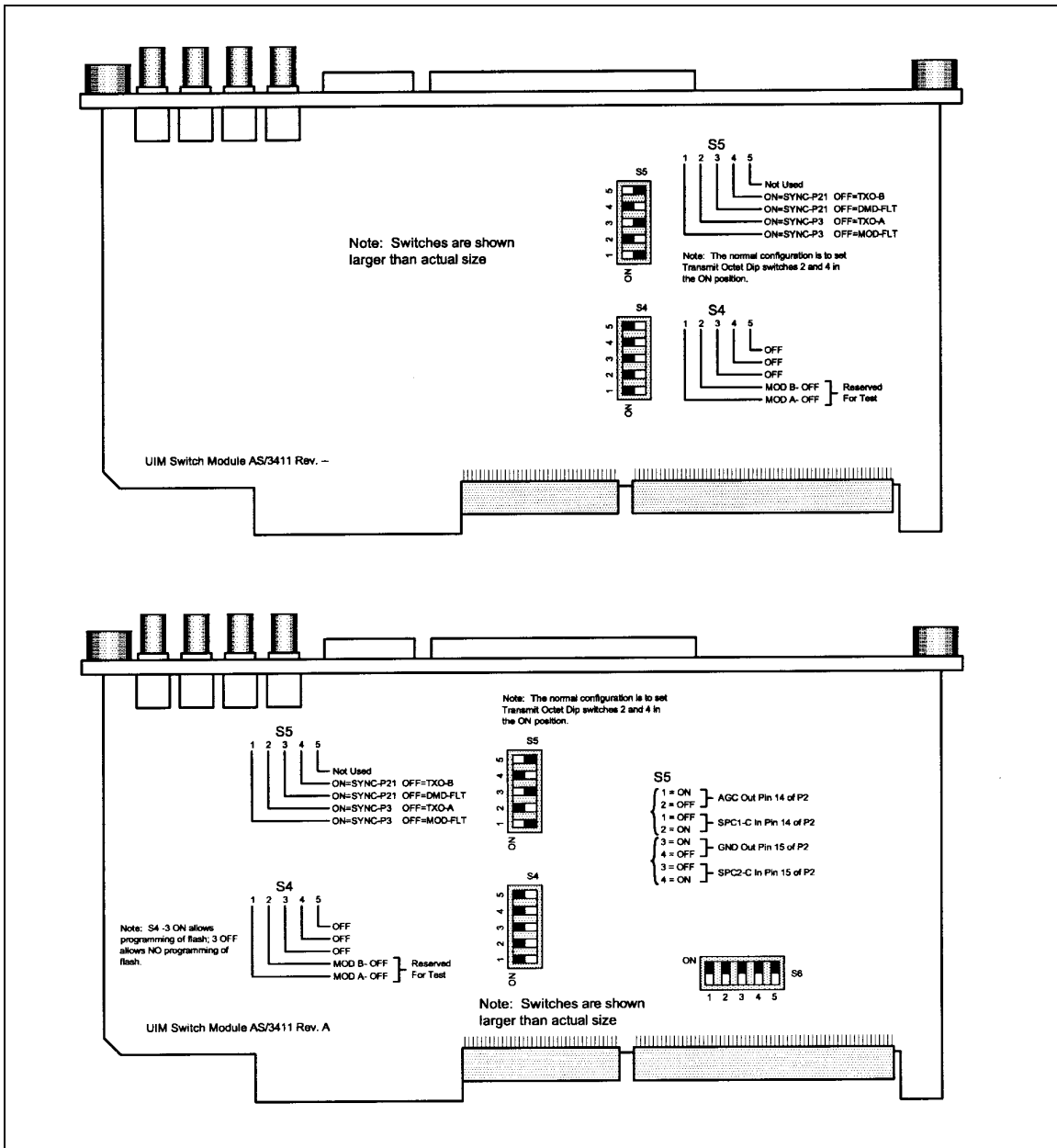

Figure 3-2. Universal Interface Modules (UIM) Dip Switch Settings

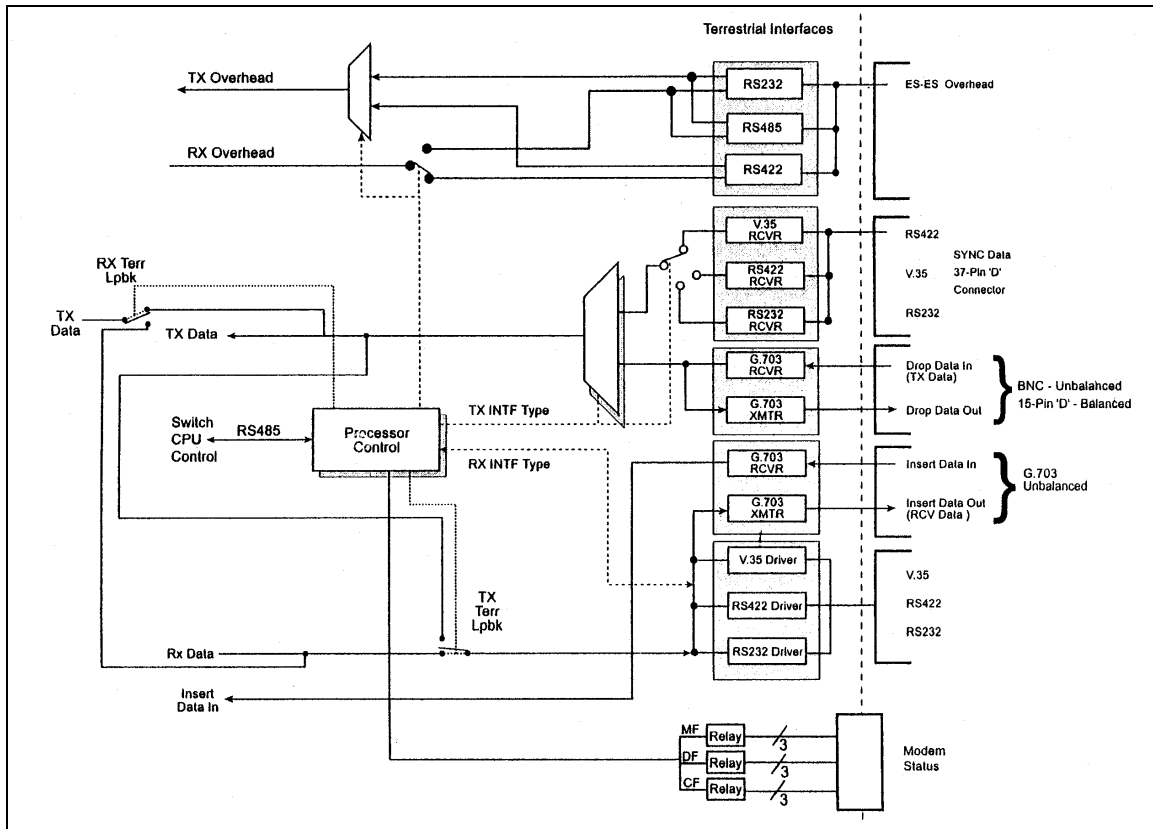

Figure 3-3. Universal Interface Modules (UIM) Functional Block Diagram

3.3 Synchronous Interface

Synchronous Tx Data and Clock enters the UIM and is routed to either the RS-422, RS-232, or V.35 Receiver as the selected M&C Processor. The signals are then converted to an RS-422 balanced format and sent to the Baseband (BB) Processor Card. Receive Data from the BB Processor Card undergoes the reverse process where it is converted from RS-422 Balanced format and routed to the RS-422 or V.35 Drivers.

3.4 G.703 Interface

Either Balanced or Unbalanced G.703 Data is routed from the 'Send Data In' Connections to the G.703 Receiver. The G.703 Receiver recovers a clock from the data stream, converts the clock and data to an RS-422 balanced format, and routes the clock and data to the BB Processor. The reverse process is performed on the Receive Data Stream where the G.703 Data exits the modem at the 'Receive Data Out' Connection. The G.703 Interface is designed to operate at the following data rates:

- T1 (1.544 Mbps)
- E1 (2.048 Mbps)
- T2 (6.312 Mbps)
- E2 (8.448 Mbps)

Additionally, the line code is selected when the interface type is selected with the exception that T1 may use B8ZS or AMI as selected at the Front Panel.

The G.703 Interface also contains two additional ports that can operate at T1 or E1 that provides a four port D&I Interface. The 'Drop Data Out' Port provides an unaltered Send Data Output that can be used for daisy chaining additional systems. On the receive side, a T1 or E1 Data Stream

can be connected to the 'Insert Data In' Port where received data will overwrite 'dropped on' the T1/E1 Data Stream. The modified T1/E1 Data Stream will then exit the modem out of the 'Receive Data Out' Port.

3.5 Earth Station to Earth Station (ES-ES) Communications Port (Async Port J9)

The UIM contains a selectable RS-232, or RS-485 Asynchronous Communications Port for Earth-Station-to-Earth-Station Communications. The data is routed from the 9-Pin "D" Connector J9 to one of the M&C Processor UARTS on the Baseband Processor Card. The baud rate and protocol can be selected from the Front Panel.

3.6 Terrestrial Loopback

The UIM also provides for terrestrial loopback. For Tx Terr Loopback, Tx Data, after passing through the Line Interface is looped back to the Rx Data line drivers. For RX Terr Loopback, the Receive Data from the satellite is looped back for retransmission to the satellite providing a far end loopback. Tx/Rx Loopback provides both loopbacks simultaneously. Refer to Figures 3-4 through 3-6 for loopback functional block diagrams.

3.7 Modem Status

The UIM provides several status indications, which are controlled by the M&C Processor.

Form-C Contacts:

The UIM provides three Form-C Relays under processor control that appear at J11.

Mod Fault:	De-energized when any transmit side fault is detected.
Demod Fault:	De-energized when any receive side fault is detected.
Common Fault:	De-energized when any fault that is not explicitly a Tx or Rx Fault such as an M&C or Power Supply Fault.

Open Collector Faults:

The UIM provides two Open Collector Faults that appear at Pins 28 & 10 on J8.

Mod Fault:	Will sink up to 20 ma (maximum) until a transmit or common fault is detected. Will not sink current if a fault is detected.
Demod Fault:	Will sink up to 20 ma (maximum) until a receive or common fault is detected. Will not sink current if a fault is detected.

The open collector faults are intended for use in redundancy switch applications in order to provide quick status indications.

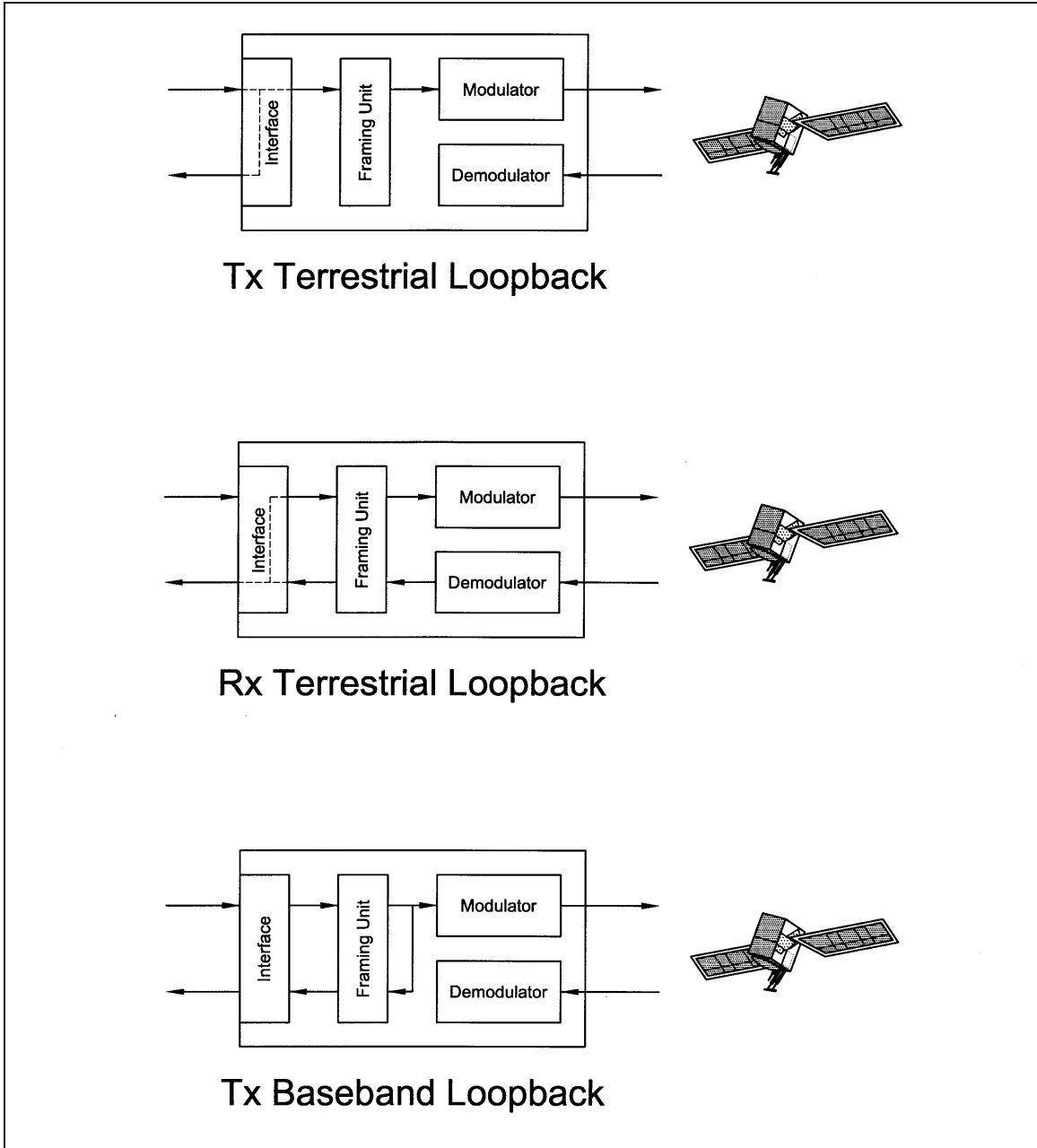

Figure 3-4. Loopback Functional Block Diagram

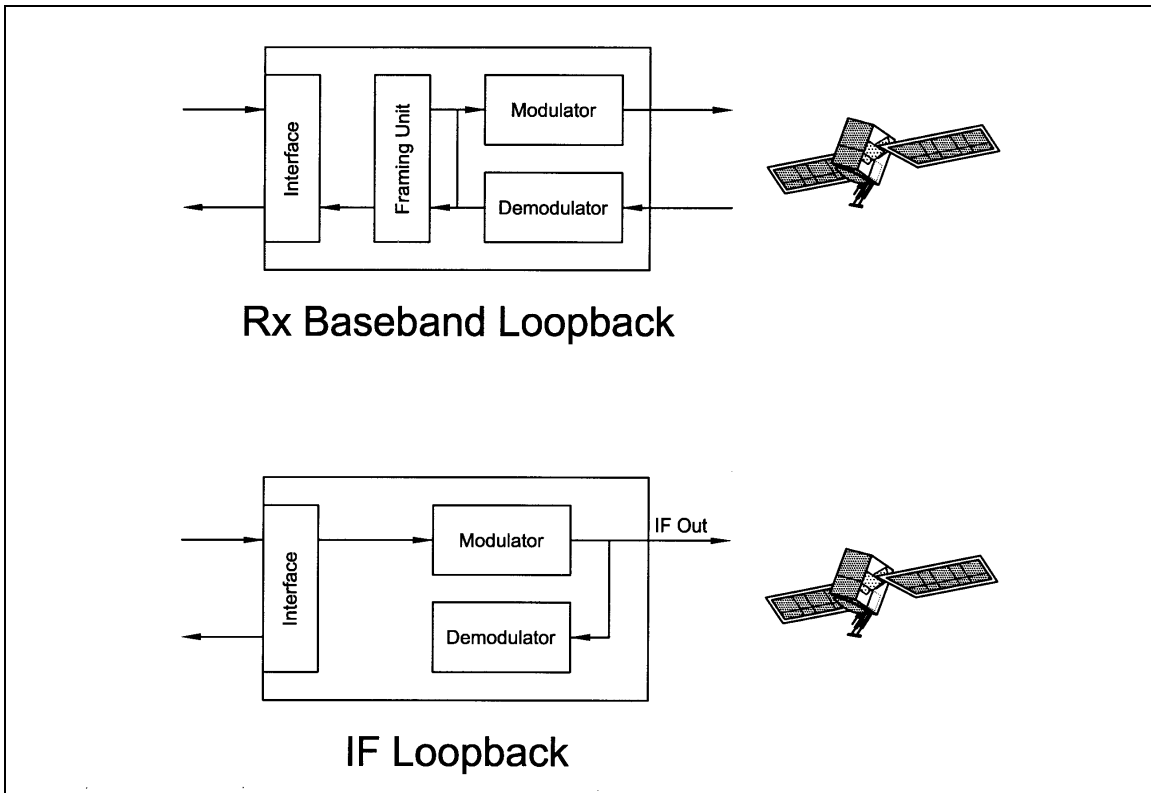

Figure 3-5. Loopback Functional Block Diagram

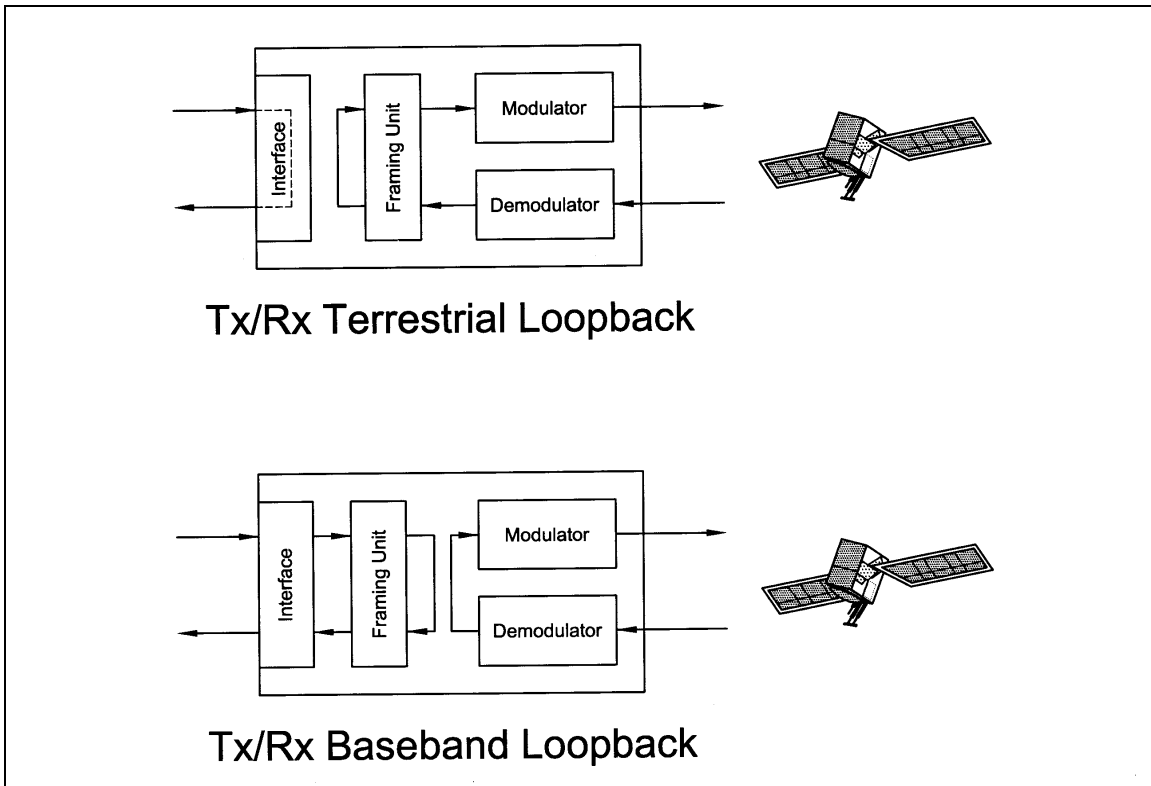

Figure 3-6. Loopback Functional Block Diagram

3.8 Baseband Processor Card

The Baseband Processor Card (BB Card) contains two major subsystems—the Baseband Processing System and the Monitor and Control Subsystem.

3.8.1 Baseband Processing

The Baseband Processor performs all of the functions required for an IBS/IDR Framing Unit, a Reed-Solomon Codec, an E1/T1 Drop and Insert System and a Turbo Codec. In addition, the Baseband Processing Section provides for Transmit clock selection and rate adaptation as well as a rate adapter and Plesiochronous/Doppler (PD) Buffer in the receive direction. A multiplexer is also provided for the SCT Clock Source for Loop Timing Applications. The transmit and receive paths may be configured independently under processor control.

3.8.2 Tx Baseband Processing

As shown in Figure 3-7, the Tx Data and Clock enters the Baseband Processor, passes through a Rate Adapting FIFO and enters the Framer/Drop Processor. In Closed-Net Mode, the data passes through the framer unaltered. In IDR, IBS, and D&I Modes, the framer adds the appropriate framing and ESC as defined in IESS-308 and 309. In D&I Mode, the framer acquires the terrestrial framing structure, E1 or T1, and synchronizes the Drop Processor. The Drop Processor extracts the desired time slots from the terrestrial data stream and feeds these channels back to the framer. The framer then places the 'dropped' terrestrial time slots into the desired satellite channel slots. The data is then sent to the Reed-Solomon Encoder.

The Reed-Solomon Encoder, if engaged, is designed as an installable option that encodes the data into Reed-Solomon Blocks. The blocks are interleaved and synchronized to the frame pattern as defined in IESS-308 and IESS-309. After Reed-Solomon Encoding, the composite data and clock are applied to the BB Loopback Circuit.

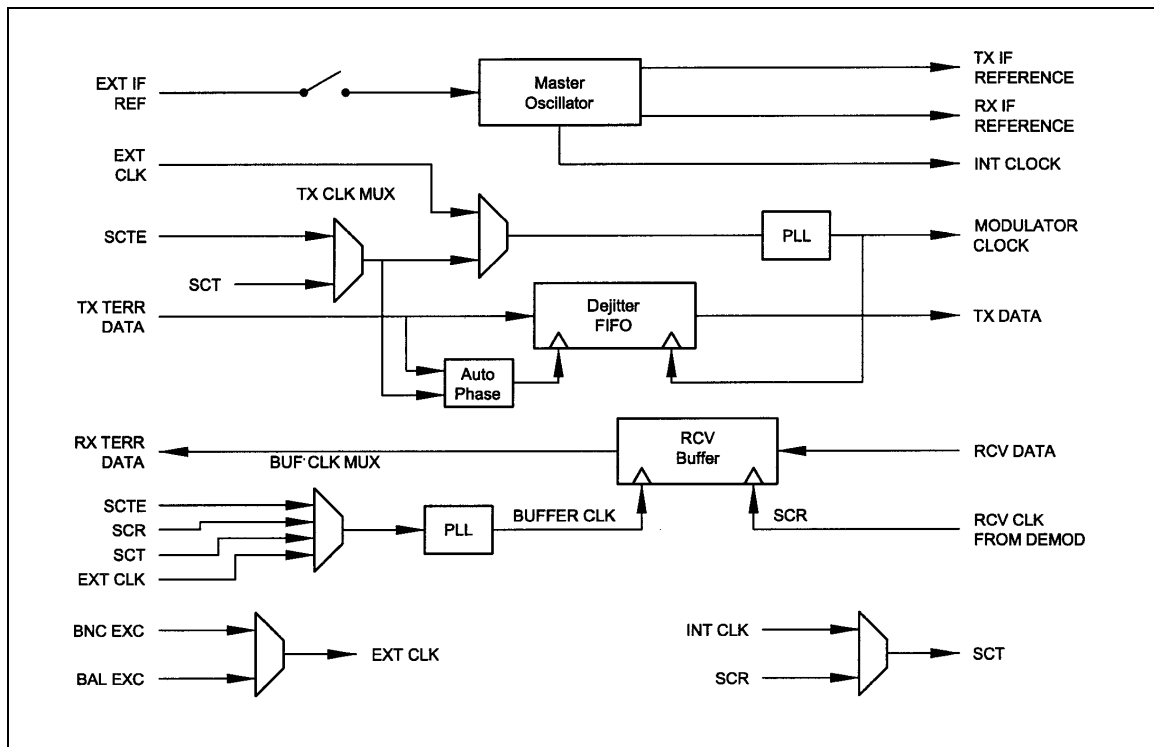

Figure 3-7. DMD15/DMD15L Clock Logic

3.8.3 Rx Baseband Processing

The Receive Processor performs the inverse function of the Tx Processor. Data received from the satellite passes through the BB Loopback Circuit to the Reed-Solomon Decoder to the Deframer. The Deframer acquires the IBS/IDR frame, synchronizes the Reed-Solomon Decoder and extracts the received data and overhead from the frame structure, placing the data into the PD Buffer, sending the overhead data to the UIM. In Closed-Net Mode, the data is extracted from the buffer and is sent to the UIM. Backward Alarm indications are sent to the M&C Subsystem. In Drop and Insert Mode, the Insert Processor synchronizes to the incoming terrestrial T1/E1 Data Stream, extracts satellite channels from the PD Buffer, and then inserts them into the desired terrestrial time slots in the T1/E1 Data Stream.

3.8.4 Clock Selection

Both the Tx Clock and the Buffer Clock source may be independently locked to one of the following:

- SCT (Internal Oscillator)
- SCTE (External Tx Terrestrial Clock)
- EXC clock (External Clock Source)
- Rx Satellite Clock (Loop Timing)

Additionally, for loop timing applications the SCT Clock Source can be selected to be Rx Satellite Clock.

3.9 Monitor & Control (M&C) Subsystem

Also contained on the BB Card is the M&C Subsystem. The M&C contains a high-performance Motorola 68302 Microprocessor and is responsible for overall command and control of modem functions. The M&C is constantly monitoring all subsystems of the modem by performing a periodic poll routine and configures the modem by responding to commands input to the system. During each poll cycle, the status of each of the subsystems is collected and reported to each of the external ports and Front Panel. Performance statistics such as E_b/N_o , buffer fill %, etc. are compiled. If faults are detected, the M&C will take appropriate actions to minimize the effect of such faults on the system (Refer to the Fault Matrices in the Section 6 (Maintenance) of this manual).

The M&C subsystem contains the following features:

3.9.1 Asynchronous Serial Port #1

This port is dedicated to the Terminal Program. With this program, all features of the modem may be controlled and monitored by any common terminal connected to the Terminal Port.

3.9.2 Serial Port #2

This port is dedicated to the Modem Remote Port. This port may be configured to support a number of synchronous or asynchronous protocols such as HDLC, and RS-485. This port is intended for use in computer-based remote M&C. All functions of the modem may be monitored and controlled from this port.

3.9.3 Serial Port #3

This port is dedicated for ES-ES Communications. The port may be configured for a number of communications protocols. Overhead data to/from the UIM is routed to/from the framer/deframer.

3.9.4 Front Panel Interface

The M&C operates the Front Panel, which includes a 2 x 12 backlit LCD, Indicator LEDs, and a Numeric Keypad.

3.9.5 Clock

The time and date is kept in order to 'time-tag' system events.

3.9.6 Watchdog Timer

The Watchdog Timer monitors the health of the M&C Subsystem.

3.9.7 Program Flash ROM

The 512K of reprogrammable program ROM (expandable to 1 MB) is available to the M&C.

3.9.8 RAM

128K RAM (expandable to 512K)

3.9.9 Non-Volatile RAM

8K of Non-Volatile RAM (expandable to 32K) is provided in order to hold the modems current configuration. In the case of power interruption, the M&C will reconfigure the modem identically to the state before power was lost.

3.10 Universal Modem

The Universal Modem (UM) Card contains a complete variable rate modulator/demodulator intended for satellite communications. The UM utilizes the latest digital technology for high reliability and versatility. The modulator and demodulator sections may be configured independently under processor control. The UM includes a dual-Band 70/140 MHz IF, QAM Modulator/Phase Lock Receiver, Convolutional Encoder/Viterbi Decoder, sequential decoding option, Differential Encoder/Decoder, and a V.35 Scrambler/Descrambler.

3.10.1 Modulator

Processed baseband data ready for transmission enters the modulator and undergoes, if the functions have been enabled, V.35 Scrambling and Differential Encoding. The data then undergoes convolutional encoding and is fed to the Dual Variable Interpolating FIR Filter. The FIR Filter shapes the data waveform to a predefined spectral mask and vectorizes the data for mapping into a PSK Constellation. The data is then converted to an analog waveform and is vector modulated onto an RF Carrier produced from the Transmit IF Synthesizer Circuitry. The final output is then fed to the IF Loopback Circuitry where under microprocessor control the Transmit Signal may be routed to the demodulator. Due to its nearly complete digital implementation, the modulator is capable of performing virtually any modulation format, and can produce almost any desired spectral mask. The modulator also houses the SCT and Reference Oscillators. The Reference Oscillator provides the frequency standard for both the modulator and demodulator. An external reference may also be selected. In this case, the Reference Oscillator is locked to the external reference.

3.10.2 Demodulator

The demodulator performs a complete digital implementation of a Variable-Rate Phase-Lock Satellite Receiver utilizing state-of-the-art digital signal processing techniques. The demodulator is capable of receiving nearly any modulation format. Signals enter the demodulator, are converted to baseband, split into 'I' In-Phase and 'Q' Quadrature Channels and digitized. The digitized I and Q Channels are then applied to a decimating FIR Matched Filter. After filtering, the signal is demodulated using a Costas Loop for recovery of the carrier and a clock recovery loop for recovery of bit timing. The demodulated data is then fed to a 1650 Viterbi Decoder, or Sequential Decoder if the option is installed. After decoding, the data is differentially decoded and descrambled.

3.11 DMD15/DMD15L Clocking Options

The following paragraphs define the types of clocking options available to the user at the Front Panel of the DMD15/DMD15L:

3.11.1 SCTE: Serial Clock Transmit External

This clock is the Transmit Terrestrial Clock associated with the interface. With the G.703 Interface selected, SCTE is the clock that is recovered from the G.703 data stream. SCTE is sometimes referred to as Tx Terrestrial Timing and for Synchronous Interfaces such as RS-422, SCTE is sometimes referred to as TT (Terminal Timing).

3.11.2 SCT: Serial Clock Transmit

This clock is an internally generated clock that is output from the modem. The clock is generally used by the Terrestrial Terminal equipment for clocking the transmit data. The frequency of the clock is set the same as the Transmit Terrestrial Clock rate if internal is selected, or is the receive clock from the Demodulator if SCR is selected. SCT is sometimes referred to as Internal Timing or ST (Send Timing).

3.11.4 EXT EXC: External Clock

This is an independent clock source. This clock is most often used if there is a station master clock. The EXT EXC can be selected, in the Interface/General Menu, to be balanced, bnc exc, sys rcs10, or IDI. IDI is used ONLY for D&I cases where external framing is selected. In this case the EXT EXC must be set to IDI where the Receive Buffer Clock is derived from the external Receive T1 or E1 Trunk.

3.11.5 BNC EXC: BNC External Clock

Unbalanced external clock input into BNC Connector J5.

Clock specification:

Frequency:	1 MHz – 10 MHz in 40 kHz steps
Level:	0.5 Vp-p – 5 Vp-p

3.11.6 BAL EXC: Balanced External Clock

This clock is input into J8-15-33, J7-7-8, or J18-13-47; all connectors are wired together for this clock and so only one connector pair should be driven at one time. The clock must meet RS-422 levels.

3.11.7 IDI: Insert Data In

This clock source is only used as an external frame source selected in D&I Mode. If External Frame Source is selected, then IDI *must* be selected for the buffer clock. For this case, a Receive T1/E1 Trunk is input into J5 and a buffer clock is derived.

3.11.8 SCR: Serial Clock Receive

This Receive Clock is recovered from the satellite's receive signal from the satellite. SCR is sometimes referred to as Receive Clock, Satellite Clock, or as RT (Receive Timing).

3.11.9 EXT IF REF: External IF Reference

This is not actually a clock, but does have some clocking implications. When the external reference is used, the master oscillator within the DMD15/DMD15L is locked to the external reference, and the internal accuracy and stability of the DMD15/DMD15L assumes that of the External Reference. Therefore, not only are the transmit and receive frequencies of the DMD15/DMD15L locked to the external reference, but the modem's internal SCT Oscillator is locked to the external reference as well.

3.12 Transmit Timing

As shown in Figure 3-7, Transmit Terrestrial Data enters the modem and is clocked into a Dejitter FIFO. Data is clocked out of the FIFO by the Modulator Clock. The Modulator Clock and Phase-Locked Loop (PLL), in conjunction with the Dejitter FIFO, reduces the input jitter. Jitter reduction exceeds the jitter transfer specified in CCITT G.821.

3.12.1 EXT CLK as TX Clock Source (RS-422 or V.35 Interface)

Data must be clocked into the modem by either the SCTE or SCT Source. If EXT CLK is selected as the Tx Clock Source, then SCTE must be supplied to the modem. The output of the dejitter buffer will be clocked with EXT CLK. This case should only be used if SCTE has excessive jitter and will degrade link performance.

3.12.2 SCT or SCTE

If SCT is selected, then only data that is synchronous to the SCT Clock is required to be supplied to the modem. It is intended for the terminal equipment to use the SCT as its clock source. The Autophase Circuit will automatically ensure that the data is clocked correctly into the modem. Therefore, a return clock is not necessary. The Clock Polarity should be set to AUTO.

If SCTE is selected, then SCTE *must* be supplied to the modem. The Clock Polarity should be set to AUTO.

3.12.3 G.703 Interface

If the G.703 Interface is selected, then the Tx Clock Source must be set to SCTE and the Clock Polarity should be set to AUTO.

3.13 Receive Timing

Any of the clocking selections, SCTE, SCT, EXT CLK, or RxSat (SCR) may be selected as the Buffer Clock. Data will be clocked out of the buffer at the data rate synchronous to the selected clock source.

3.14 Loop Timing

If loop timing is desired (i.e.; the modem timing is slaved to the far end master station), the modem clocks can be configured as follows:

3.14.1 Transmit (RS-422 or V.35 Interface)

Set SCT Source to 'SCR'. The Tx Terminal Equipment must clock the TX Data with the SCT Clock and return data and SCTE (Optional). If SCTE is returned to the modem from the terminal equipment, set TX CLK to SCTE. If SCTE is not returned to the modem, set TX CLK to SCT. The TX CLK PHASE should be set to AUTO.

3.14.2 G.703 Interface or Asymmetrical Data Rates

Loop timing with a G.703 Interface or Asymmetrical Data Rates requires external equipment at the remote end that is capable of using the recovered RD Clock as source timing for (SCTE) SD. The modem will not manipulate the clock frequency. Therefore, the transmit and receive clock rates must be equal in order for the modem to perform loop timing.

3.14.3 Receive

Select the Buffer clock to RxSAT (SCR).

3.15 Drop and Insert (D&I)

The Radyne DMD15/DMD15L Drop and Insert (D&I) Function provides an interface between a full T1 or E1 Trunk whose framing is specified in CCITT G.704 and a fractional Nx64 Kbps Satellite Channel that conforms to the IBS and small IDR Framing Structures. The Drop function allows the user to select the terrestrial T1 or E1 timeslots that are to be dropped off for transmission over the link in the specified satellite channels.

The Insert function allows the user to select the T1 or E1 timeslots into which the received satellite channels are to be inserted. The two functions are completely independent allowing maximum flexibility in choosing configurations. The four-port G.703 Interface allows one or more modems to be looped together using the same T1 or E1 trunk.

The Transmit Data Trunk is brought into the modem via the Send Data In (SDI) Port. From there, the TX Baseband Processor extracts the selected timeslots from the G.704 Frame and prepares them for transmission. The original trunk data is sent out of the modem unaltered via the Send Data Out (SDO) Port. The Receive Data Trunk is brought into the modem via the Insert Data In (IDI) Port. The data is buffered inside the modem and the RX Baseband Processor inserts satellite data into the selected timeslots in the G.704 Frame. The modified terrestrial trunk is then output via the Receive Data Out (RDO) Port.

Figure 3-8 shows two modems looped together. This configuration could be simplified to just use one modem, or extended to use more than two modems. Figure 3-9 shows an alternative method of looping where all of the drop (transmit) data is processed prior to performing any insert (receive) processing. In both configurations, the terrestrial trunk is providing the timing for the satellite transmission and for the terrestrial receive.

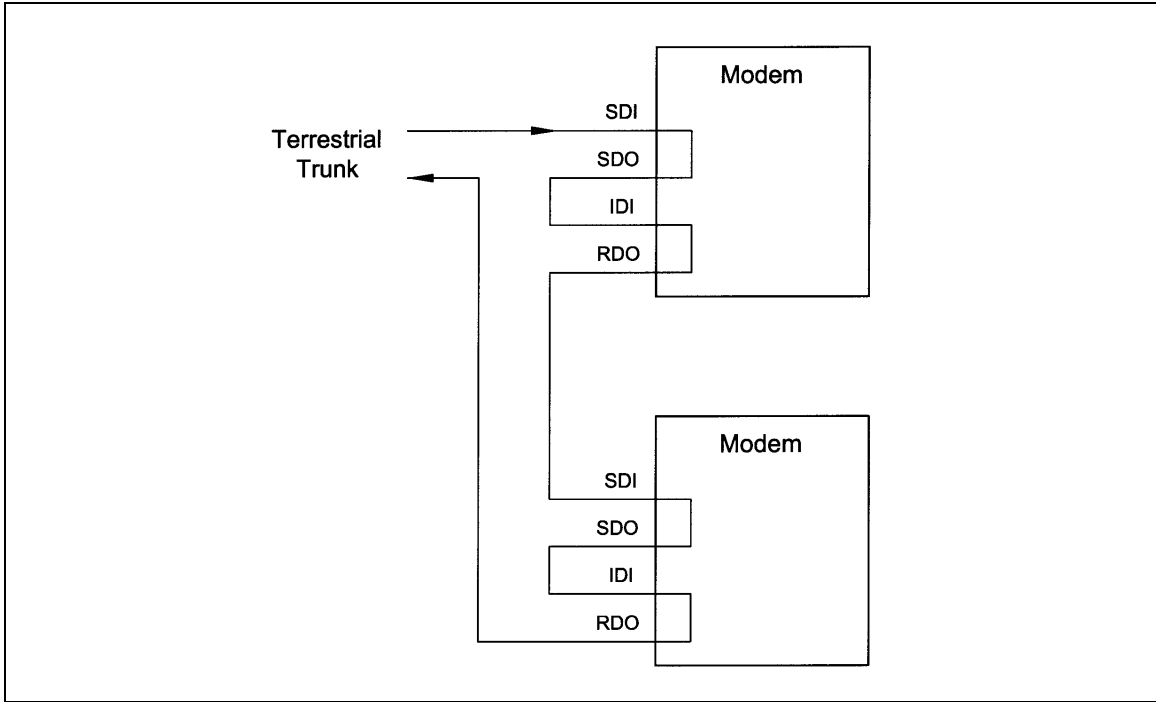

Figure 3-8. Looped Modems

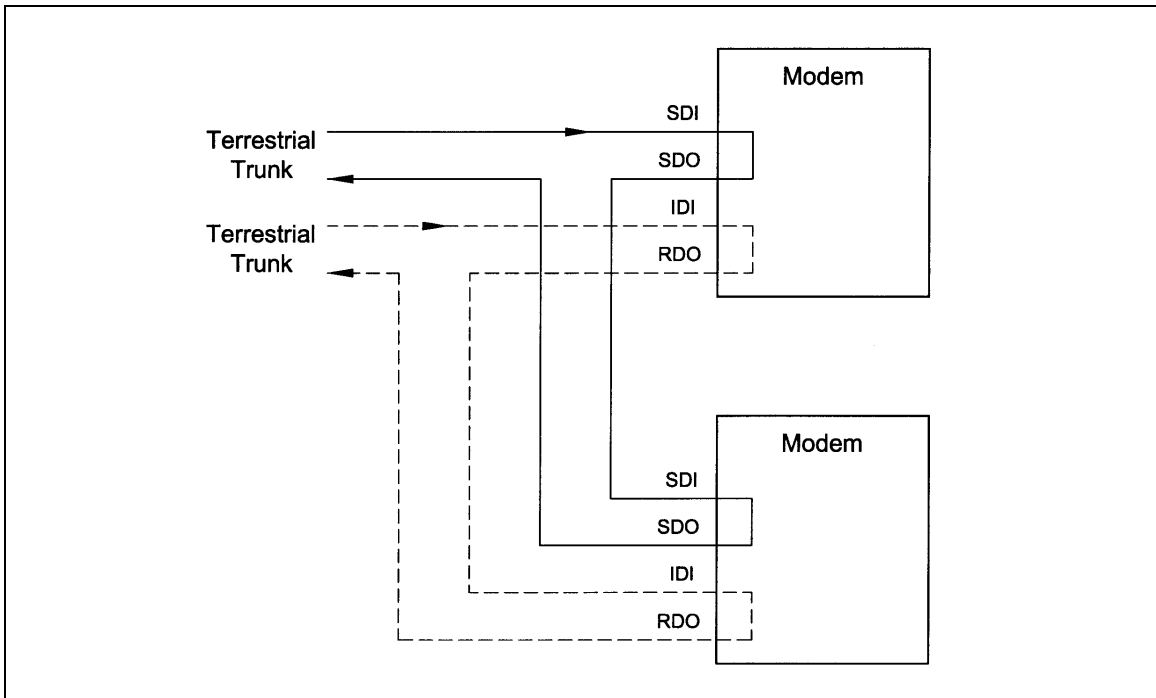

Figure 3-9. Looped Modems with Separate D&I Trunks

3.15.1 Drop Only

When Drop is enabled and Insert is disabled, the DMD15/DMD15L performs a drop-only function. Framed E1 or T1 Data is input via the Send Data In Port, the selected timeslots are dropped into the IBS frame structure, and the unaltered terrestrial data is output via the Send Data Out Port (refer to Figure 3-10).

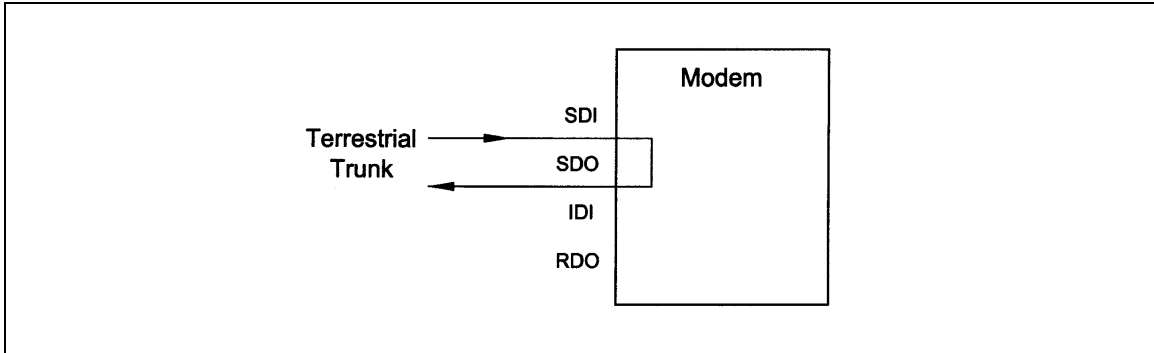

Figure 3-10. Drop Only

3.15.2 Insert Only

When Insert is enabled and Drop is disabled, the DMD15/DMD15L performs an insert-only function. If framed terrestrial E1 or T1 Data is available, it should be input via the Insert Data In Port. The Terrestrial Data is buffered inside the Modem. The RX Baseband Processor inserts satellite data into the selected timeslots in the G.704 Frame and the modified terrestrial data is then output via the Receive Data Out Port (refer to Figure 3-11).

If framed terrestrial data is not available, selection of the Internal T1/E1 frame source will cause the modem to generate the required G.704 Frame. The Satellite Data will be inserted into the selected timeslots, and the resulting terrestrial data will be output via the Receive Data Out Port. Any non-inserted timeslots in the G.704 Frame will be filled with the appropriate Idle Code (refer to Figure 3-12).

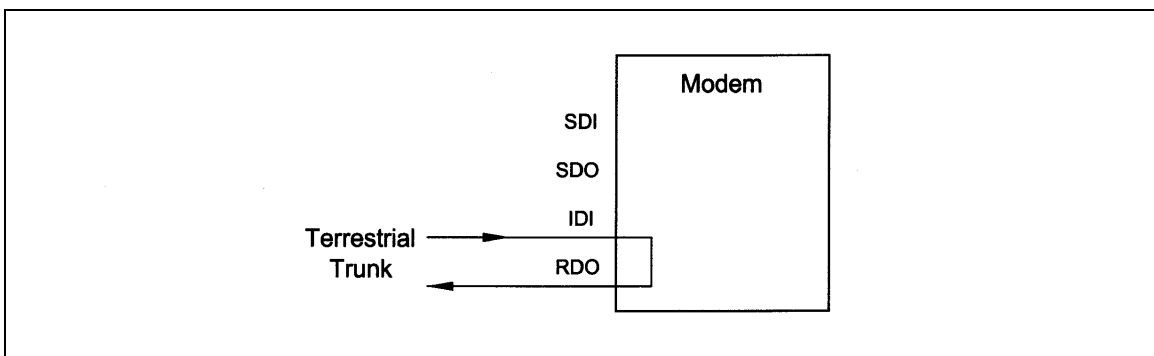

Figure 3-11. Insert Only with External Frame Source

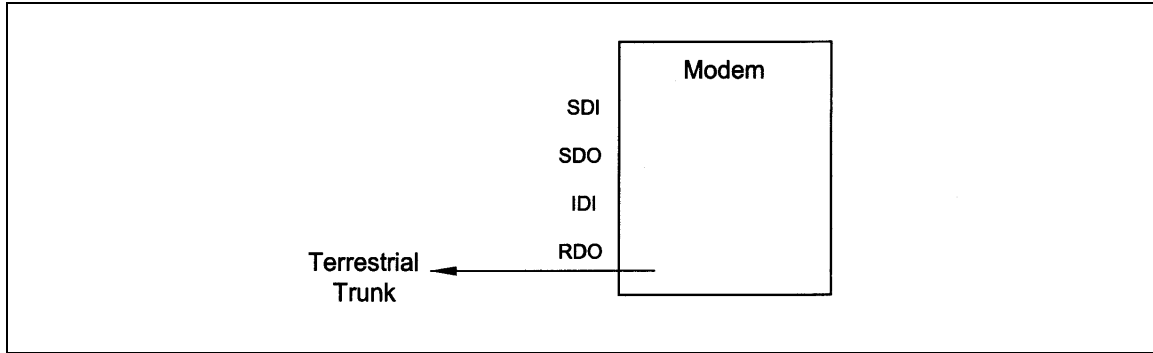

Figure 3-12. Insert Only with Internal Frame Source

3.16 Mode Selection

The DMD15/DMD15L D&I can be easily configured to support several commonly used terrestrial data formats. For E1 Data, the user can choose between PCM-30, PCM-30C, PCM-31 and PCM-31C. For T1 Data, the user can choose between T1-D4, T1-ESF, and SLC-96. The following paragraphs provide more information on the various mode selection capabilities of the DMD15/DMD15L.

3.16.1 PCM-30

The PCM-30 Mode of Operation supports an E1 Interface with Multiframe Alignment (MFAS) and Channel Associated Signaling (CAS). The user may independently program n timeslots to drop and n timeslots to insert where $n = 1, 2, 3, 4, 5, 6, 8, 10, 12, 15, 16, 20, 24, \text{ or } 30$. In addition to the selected drop timeslots, the Transmit Function also extracts the appropriate ABCD signaling bits from terrestrial timeslot 16 for transmission in IBS Frame as required. Conversely, the Receive Function extracts received ABCD signaling bits from the IBS Frame and inserts them in timeslot 16 of the appropriate terrestrial frame. This transmission and reception of ABCD signaling based upon the drop and insert timeslots is performed automatically and is transparent to the user. In PCM-30 mode, the user may *not* select timeslot 16 as a Drop or Insert Timeslot.

3.16.2 PCM-30C

The PCM-30C Mode of Operation supports an E1 Interface with Multiframe Alignment (MFAS) and Channel Associated Signaling (CAS). In addition, the Drop function verifies the received terrestrial CRC checksum and the Insert function calculates the required CRC checksum. The user may independently program n timeslots to drop and n timeslots to insert where $n = 1, 2, 3, 4, 5, 6, 8, 10, 12, 15, 16, 20, 24, \text{ or } 30$. In addition to the selected Drop timeslots, the Transmit Function also extracts the appropriate ABCD signaling bits from terrestrial timeslot 16 for transmission in IBS Frame as required. Conversely, the Receive Function extracts received ABCD signaling bits from the IBS frame and inserts them in timeslot 16 of the appropriate terrestrial frame. This transmission and reception of ABCD signaling based upon the Drop and Insert timeslots is performed automatically and is transparent to the user. *In PCM-30C Mode, the user may not select timeslot 16 as a Drop or Insert Timeslot.*

3.16.3 PCM-31

The PCM-31 Mode of Operation supports an E1 Interface with no Multiframe Alignment (MFAS) or Channel Associated Signaling (CAS). The user may independently program n timeslots to drop and n timeslots to insert where $n = 1, 2, 3, 4, 5, 6, 8, 10, 12, 15, 16, 20, 24, \text{ or } 30$. Because there is no implied ABCD signaling, the user is free to select timeslot 16 as a Drop or Insert Timeslot.

3.16.4 PCM-31C

The PCM-31C Mode of Operation supports an E1 Interface with no Multiframe Alignment (MFAS) or Channel Associated Signaling (CAS). In addition, the Drop Function verifies the received terrestrial CRC checksum and the Insert Function calculates the required CRC checksum. The user may independently program 'n' timeslots to drop and 'n' timeslots to insert where 'n' = 1, 2, 3, 4, 5, 6, 8, 10, 12, 15, 16, 20, 24, or 30. Because there is no implied ABCD signaling, the user is free to select timeslot 16 as a Drop or Insert Timeslot.

3.16.5 T1-D4/T1-D4-S

The T1-D4 Mode of Operation supports a T1 Interface with 12 frames per multiframe. The user may independently program n timeslots to drop and n timeslots to insert where n = 1, 2, 3, 4, 5, 6, 8, 10, 12, 15, 16, 20, 24, or 30. In the DMD15/DMD15L, Robbed Bit Signaling (RBS) is handled without any need for operator intervention and is transparent to the user.

3.16.6 T1-ESF/ T1-ESF-S

The T1-ESF Mode of Operation supports a T1 Interface with 24 frames per multiframe. The CRC-6 checksum is automatically checked by the Drop Function and generated by the Insert Function and placed in the appropriate F-bit positions in the terrestrial multiframe. The user may independently program n timeslots to drop, and n timeslots to insert, where n = 1, 2, 3, 4, 5, 6, 8, 10, 12, 15, 16, 20, 24, or 30. In the DMD15/DMD15L, Robbed Bit Signaling (RBS) is handled without any need for operator intervention and is transparent to the user.

3.16.7 SLC-96

The T1 SLC-96 Mode supports a T1 Interface with 12 Frames per Multiframe (as per T1-D4) with the following exceptions:

The signaling frames (F_s bits) are sent twice in succession.
During the subsequent four signaling frames, the F_s bits are replaced with data link information bits.

The data frame is composed of six signaling frames with a length of 9 msec. The user may independently program n timeslots to drop, and n timeslots to insert, where n = 1, 2, 3, 4, 5, 6, 8, 10, 12, 15, 16, 20, 24, or 30. In the DMD15/DMD15L, Robbed Bit Signaling (RBS) is handled without any need for operator intervention and is transparent to the user.

3.17 Multidestinational Systems

Because the Drop and Insert Functions are completely independent, the DMD15/DMD15L easily supports multidestinational communications. Figure 3-13 illustrates a Multidestinational System with one Hub site and three remote sites. At the Hub site, thirty channels are being transmitted to all three remote sites and a fractional set of channels is being received from each remote site. At the other end of the link, each remote site is transmitting a fractional E1 to the Hub site as well as receiving all thirty (30) channels from the Hub site. It also identifies those channels intended for it, and inserts them into the terrestrial data stream.

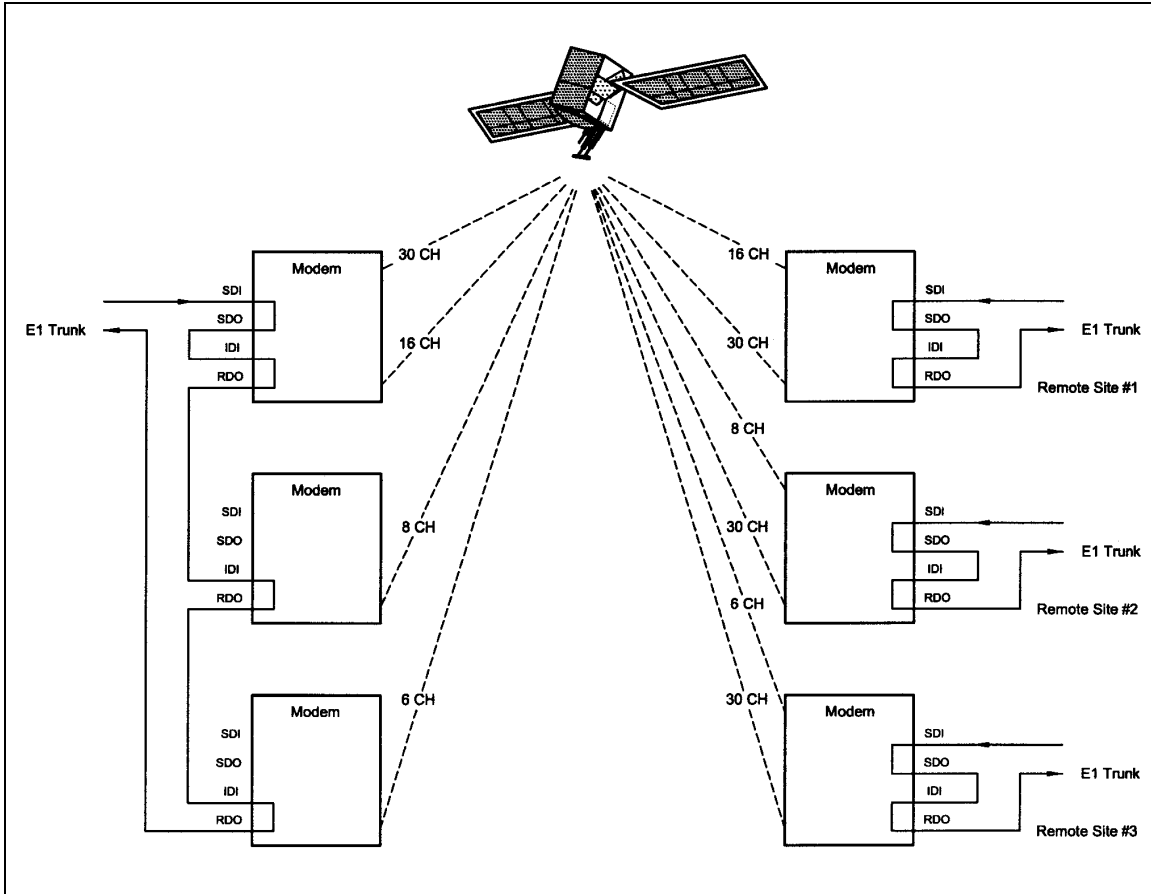

Figure 3-13. Multidestinational Communications

3.17 Drop and Insert Mapping

The following displays under Interface D&I Setup (both Tx and Rx), are editing displays only:

SATCh TS
Enter to Edit

Any changes made in these displays are made on the screen, **but are not entered into the modem**. Once these menus are configured, the Mapping Menu must be used to actually enter the settings into the modem.

Example :

For a modem w/ Drop & Insert enabled at a data rate of 256 (with timeslots assigned 1-1, 2-2, etc.). At a data rate of 256, the modem will allow 4 channels to assign timeslots to. Under the Tx Menu, assign the timeslots that are to be used to the 4 channels. CH1 is assigned to TS1 (Timeslot #1), CH2 to TS 2, CH3 to TS3 and CH4 to TS4, <ENTER> must be depressed after assigning each individual TS. Once the timeslots are assigned to the channels, use the Left or Right Arrow Key to scroll to the Mapping Menu. This menu will appear in the following way:

Map Copy
***** *****

This is the menu where the channel assignments are actually entered into the modem. To do this, perform the following steps:

For the Transmit Side:

1. Push <ENTER> to get the flashing cursor.
2. Use the Up Arrow Key to make the left portion of the display read "TX EDIT".
3. Use the Right or Left Arrow Keys to switch the flashing cursor to the right portion of the display.
4. Use the Up or Down Arrow Key to make the right hand portion read "TX ACTIVE".
5. The mapping display should now look like this:

Map Copy
TX EDIT > TX ACTIVE

6. Push <ENTER> to enter this command. This tells the modem to configure to the settings that were assigned in the Channel/Timeslot display.

For the Receive Side:

1. With Rx Side Channels configured as follows: CH1 to TS1, CH2 to TS2, CH3 to TS3 and CH4 to TS4.
2. After the timeslots are assigned properly, scroll to the Mapping Menu and use the above procedure to enter the settings into the modem.
3. Set the display to read:

Map Copy
RX EDIT > RX ACTIVE

4. Press <ENTER> to enter the settings into the modem.

To View the current Timeslot Assignment:

1. If there is a question of the channels not being entered properly, the Mapping Menu may be used to see how the channels/timeslots are configured in the modem.
2. Use <ENTER> and the Arrow Keys to make the mapping menu read (for the Tx Side):

Map Copy
TX ACTIVE > TX EDIT

3. Press <ENTER>. The modem has now copied the current Tx Settings to the Tx Channel/Timeslot Display.
4. For the Rx Side:

Map Copy
RX ACTIVE > RX EDIT

5. Press <ENTER>. The modem has now copied the current Rx Settings to the Rx Channel/Timeslot display).

Note: *It is not mandatory to assign timeslots in sequential order, although the lowest timeslot must be entered in the lowest channel. For example: timeslots may be assigned 1-2, 2-5, etc. but not 1-5, 2-2.*

3.18 Reed-Solomon Codec (Refer to Figures 3-14, 3-15, and Table 3-1)

Utilizing a Reed-Solomon (RS) Outer Codec concatenated with a Convolutional Inner Codec is an effective way to produce very low error rates even for poor signal-to-noise ratios while requiring only a small increase in transmission bandwidth. Typically, concatenating an RS Codec requires an increase in transmission bandwidth of only 9 – 12% while producing a greater than 2 dB improvement in E_b/N_0 . RS is a block Codec where K data bytes are fed into the encoder which adds $2t = (N - K)$ check bytes to produce an N byte RS block. The RS decoder can then correct up to “t” erred bytes in the block.

3.18.1 Operation in the DMD15/DMD15L

When the Reed-Solomon Codec is enabled, data is fed to the RS Encoding Section of the DMD15/DMD15L where it is scrambled, formed into blocks, RS encoded, and interleaved. Unique words are added so that the blocks can be reformed in the Receiving Modem (Refer to Figure 3-13). Data is then sent to the modulator where it is convolutionally encoded, modulated and transmitted to the satellite.

When the signal is received and demodulated by the Receiving Modem, it is fed to a Viterbi Decoder for the first layer of error correction. After error correction is performed by the Viterbi Decoder, the unique words are located and the data is deinterleaved and reformed into blocks. The RS Decoder then corrects the leftover errors in each block. The data is then descrambled and output from the RS Section.

3.18.2 Reed-Solomon Code Rate

The RS Code Rate is defined by (N, K) where N is the total RS block size in bytes - data + check bytes - and K is the number of data bytes input into the RS Encoder. The transmission rate expansion required by the RS Codec is then defined by N/K. The DMD15/DMD15L automatically sets the correct RS code rate for IDR/IBS open network operation in accordance with the data shown in Table 3-1. In Closed Net Mode, the DMD15/DMD15L allows any N or K setting up to $N = 255$, and $K = 235$ to allow tailoring of the code rate to meet system requirements.

3.18.3 Interleaving

The DMD15/DMD15L allows for interleaving depths of 4 or 8 RS Blocks. This allows burst errors to be spread over 4 or 8 RS blocks in order to enhance the error correcting performance of the RS Codec. For Open Network Modes, the DMD15/DMD15L automatically sets the interleaving depth to 4 for QPSK or BPSK or 8 for 8PSK. In Closed Network Mode, the interleaver depth can be manually set to 4 or 8.

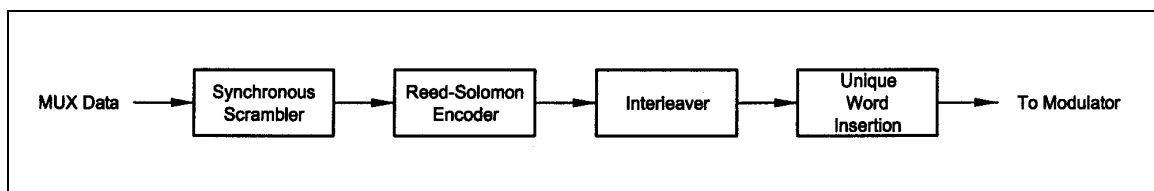

Figure 3-14. Reed-Solomon Encoder Functional Block Diagram

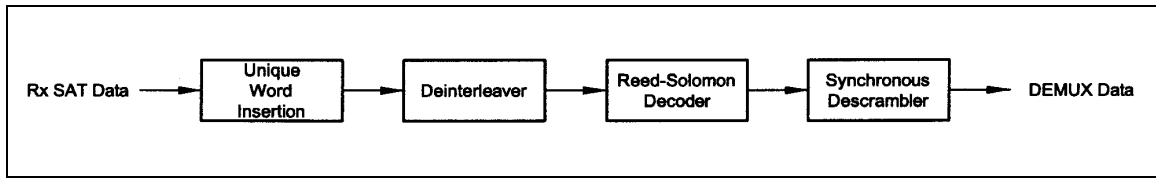

Figure 3-15. Reed-Solomon Decoder Functional Block Diagram

Table 3-1. Reed-Solomon Codes for IDR					
Type of Service	Data Rate (Kbps)	RS Code (n, k, t) ¹	Bandwidth Expansion [(n/k) -1]	Interleaving Depth	Maximum ² RS Codec Delay (ms)
Small IDR (With 16/15 O/H)	64	(126, 112, 7)	0.125	4	115
	128	(126, 112, 7)	0.125	4	58
	256	(126, 112, 7)	0.125	4	29
	384	(126, 112, 7)	0.125	4	19
	512	(126, 112, 7)	0.125	4	15
	768	(126, 112, 7)	0.125	4	10
	1024	(126, 112, 7)	0.125	4	8
	1536	(126, 112, 7)	0.125	4	5
IDR (With 96 Kbps O/H)	1544	(225, 205, 10)	0.0976	4	9
	2048	(219, 201, 9)	0.0896	4	7
	6312	(194, 178, 8)	0.0899	4	2
	8448	(194, 178, 8)	0.0899	4	<2
8PSK	1544	(219, 201, 9)	0.0896	8	18
	2048	(219, 201, 9)	0.0896	8	13
	6312	(219, 201, 9)	0.0896	8	4
	8448	(219, 201, 9)	0.0896	8	3

NOTES:

1. n = code length, k = information symbols and t = symbol error correcting capability.
2. Design objective.

3.19 DMD15 Automatic Uplink Power Control (AUPC Operation)

The DMD15 Modem has an optional built-in provision for Automatic Uplink Power Control (AUPC). AUPC attempts to maintain a constant E_b/N_0 at the receive end of an SCPC link. This is especially useful when operating over a satellite at Ku-Band Frequencies in locations with high rainfall periods.

Note: An Asynchronous or IBS Interface is required for AUPC. Also, IBS (Async Framing Mode) MUST be selected to provide a channel for AUPC operation.

The IBS Async Framed Data Mode provides a service channel between the two sites of a link permitting the modem processors to send messages and get responses over this channel. AUPC can be set to operate on either or both directions of a link but always requires a bi-directional channel. Therefore, both the Modulator and Demodulator interface mode must be set to IBS Async for the AUPC menus to be visible and for the AUPC function to operate properly. The AUPC Functions and their descriptions are shown on Table 3-2.

Table 3-2. AUPC Functions	
Function	Description
AUPC ENABLE/DISABLE	Enables/Disables the AUPC to function locally
AUPC Eb/No	Desired E_b/N_0 of remote modem
AUPC MIN LVL	Sets minimum output power to be used
AUPC MAX LVL	Sets maximum output power to be used
AUPC DEF LVL	Sets default output power to be used

Note: The AUPC menus are located under the Modulator Menu as shown in Section 4.

The basic AUPC Operation is described as follows:

Assume that the two modems, one at each end of the link, are set to AUPC operation. Only one direction is discussed, but the same functions could be occurring in both directions simultaneously. Modem "A" is transmitting to modem "B" under normal conditions and modem "B" has a receive E_b/N_0 of 7.5 dB. Modem "A" has been set to an AUPC E_b/N_0 on the Front Panel of 7.5 dB, and is currently outputting -15 dBm. Next, it begins raining at location "B", and the E_b/N_0 drops to -7.0 then -6.8 dB. Modem "B" is constantly sending update messages to "A" and reports the current E_b/N_0 . When "A" sees the drop in E_b/N_0 , it slowly begins to raise the output power, and raises it again when it sees further drops. As the rain increases in intensity, and the E_b/N_0 decreases again, "A" continues to increase its power level to compensate, and when the rain diminishes and quits, it lowers its power level to compensate. The operation is therefore a feedback control loop with the added complication of a significant time delay.

There are safeguards built into the AUPC System. First, the Modulator has two additional parameters, which allow control of the Maximum and Minimum Power Output Levels. Second, a default power level is specified which takes precedence over the output power level during signal loss or loss of AUPC Channel Communication. The default power level should normally be set to a high enough level to reestablish communication regardless of rain fade. The other controls are built into the operating control software to limit response times and detect adverse operating conditions.

3.20 DMD15 Asynchronous Overhead Operation

3.20.1 Asynchronous Framing/Multiplexer Capability

The Asynchronous Framing/Multiplexer is capable of multiplexing a relatively low-speed overhead channel onto the terrestrial data stream resulting in a slightly higher combined or aggregate data rate through the modem. The overhead channel is recovered at the far end. This added channel is termed variously "An Overhead Channel", "Service Channel", "Async Channel" or in IESS terminology an "ES to ES Data Channel." The basic frame structure used by the multiplexer is that specified in the IESS-309 Standard, resulting in a 16/15 Aggregate to Through-Data Ratio.

For Regular Async: (Standard IBS), the Baud Rate is approximately 1/2000 of the Data Rate listed in Table 3-3.

For Enhanced Async: (IBS Async.), the Baud Rate is selectable, but Data Rate is limited.

The maximum Baud Rate is 19,200 bps for IBS Async. Two software-controlled modes are designed into the card to best utilize the available bits; "Standard IBS" and "IBS (Async)". The characteristics of the Channel Interface is also determined by the standard or Async mode.

The Async Channel can be set under software-control to either RS-232 or RS-485 mode. The pin assignments for both modes are shown in Table 3-3. The "RS-485" Setting controls the output into tri-state when the modem is not transmitting data, allowing multiple modem outputs to be connected together.

Table 3-3			
Kbps	Baud Rate Example for Standard IBS	Kbps	Baud Rate Example for Enhanced Mode
128	64	9.6	300
256	128	19.2	600
384	192	32	600
512	256	64	1200
640	320	128	2400
768	384	192	4800
896	448	256	4800
1024	512	320	9600
1152	576	384	9600
1280	640	448	9600
1408	704	512	9600
1536	768	576	9600
1664	832	640	19200
1792	896	704	19200
1920	960	768	19200
1920	960	768	19200
2048	1024	832	19200

		896	19200
		960	19200
		1024	19200
		1088	19200
		1152	19200
		1216	19200
		1280	19200
		1344	19200
		1408	19200
		1472	19200
		1536	19200
		1600	19200
		1664	19200
		1728	19200
		1792	19200
		1856	19200
		1920	19200
		1984	19200
		2048	19200

3.21 Standard IBS Mode

In the first or “Normal” mode, all bit assignments are per the IBS standard. The bits of Overhead Housekeeping byte 32 are implemented as shown in Table 3-4 below:

Table 3-4.		
Bit 1	ES to ES Data Channel	This bit is routed directly to the ES to ES Data Channel. Its data rate is 1/512 th of the aggregate rate (or 1/480 th of the through terrestrial data rate), and is normally used to super-sample an asynchronous data channel.
Bit 2	Frame Alignment	Part of the Frame Alignment word.
Bit 3	Backward Alarm	Transmit and Receive with main processor to activate Main Alarm/LED.
Bit 4	Multiframe Message	As per IBS.
Bits 5 and 6	Spare	Not currently utilized.
Bits 7 and 8	Encryption Utilization	Not currently utilized.

The ratio of the Through Terrestrial Data Channel Rate to the aggregate rate is 15/16. The standard transmit and receive channels of the ES to ES Data Channel in Standard IBS Mode are raw channels operating at the specific bit rate as controlled by the data channel rate, without buffering. In addition, no clocks are provided with this channel. Since it would be rare that the data rate provided was exactly that required for a standard rate device, the only method of communicating using this channel is to allow it to super-sample the user data.

3.22 Asynchronous Multiplexer Mode

Since many of the frame bits in the standard IBS mode are not used, an “Enhanced” Multiplexer Mode has been implemented that can be engaged under software control. Since this mode changes the use of many of the framed non-data bits, this mode is only usable when the DMD15 is at both ends of a link. In this mode, the overhead signaling bytes 16 and 48 can be used to implement a significantly higher speed ES to ES Data Channel under software control. When implemented, this rate is 16 times that of the normal IBS standard, or 1/30th of the terrestrial data rate (1/32nd of the aggregate rate).

Note: The IBS Async mode MUST be selected for true Asynchronous channel operation to be available.

3.23 ESC Backward Alarms

When running in IDR Mode and if the modem has the ESC Option, there will be four Backward Alarms available for use by the earth stations at each end of the link (both ends must have the ESC option). These alarms are accessed via the ESC ALARMS Port. The four alarms are controlled by four relays, each having a normally open, normally closed, and a common connection. The common connections of these relays (referred to as Backward Alarm Inputs) can be connected to whichever system on the earth station that the user wishes to trigger the backward alarm. When ground is applied to the Common (Input) Connection of one of these relays, that relay and associated backward alarm will then be in a “no fault” state. When the ground is removed, the relay and the associated Tx Backward Alarm will toggle to the faulted state. When in the faulted state, the receive end of the link will receive that backward alarm that is initiated at the transmit end of the link.

The user can connect whichever systems on the earth stations that they desire to these Backward Alarms Relays as long as they will supply ground to the Backward Alarm Relay Input in the “no fault” condition and the ground will be removed in the “faulted” condition.

For example: the user could connect the Demod Summary Fault of the modem to the Backward Alarm 1 Input, so that if the demod went into Major Alarm (such as a Carrier Loss), Backward Alarm 1 would be transmitted to the receive end of the link. At the receive end, it would show up as Rx Backward 1 (Receive Backward Alarm 1).

3.23.1 To Disable the ESC Backward Alarms

If the ESC ALARMS Port will not be used and the Backward Alarm Indications are to be disabled, connect the following pins of the ESC ALARMS Port:

Connect Pins 1, 10, 11, 22 and 23 (connect all together). Pin 1 is ground and Pins 10, 11, 22, and 23 are the inputs of Backward Alarms 1 through 4. By connecting these four pins to ground (Pin 1) the Backward Alarms will be disabled and indicate “PASS” for BK1 through BK4.

3.24 Reacquisition

Reacquisition on the DMD15/DMD15L is the ability to reacquire a lost signal from a far end modulator that returns at some point. The DMD15/DMD15L allows the user to program the amount of time (0.0 – 900.0 seconds) that the demodulator will wait for the signal to reappear before searching the entire programmed sweep range for the signal. Additionally, the DMD15/DMD15L allows the user to specify the range ($\pm 0 - 32000$ Hz) in which the demodulator will perform the narrow signal search (see Figure 3-16). Configuration can be accomplished via the standard user interfaces (front panel, dumb terminal, remote).

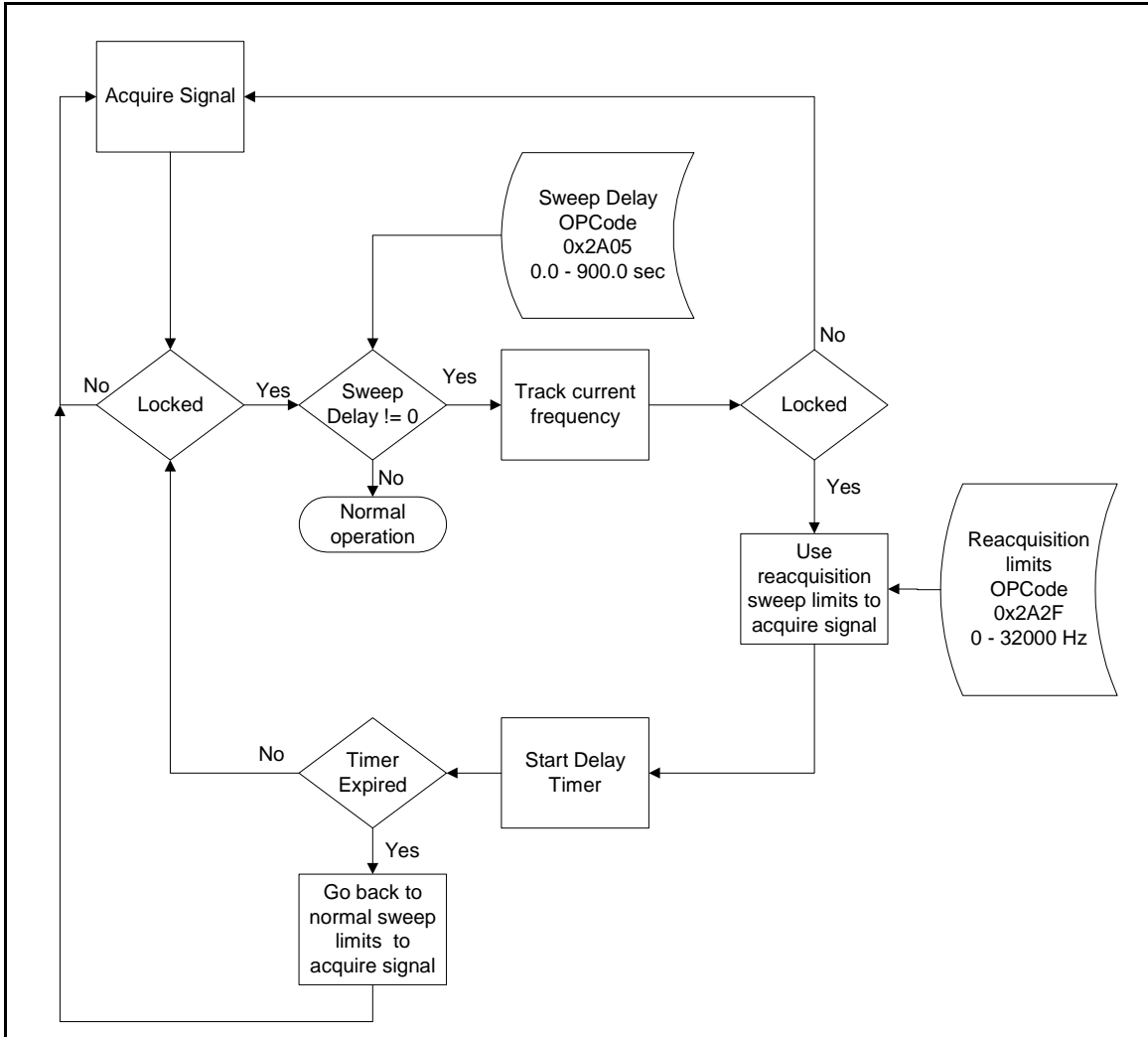

Figure 3-16. Reacquisition flow in the DMD15/DMD15L



Section 4 – User Interfaces

4.0 User Interfaces

There are three user interfaces available for the DMD15/DMD15L. These are:

- Front Panel
- Remote Port
- Terminal

4.1 Front Panel User Interface

The Front Panel of the DMD15/DMD15L allows for complete control and monitor of all DMD15/DMD15L parameters and functions via a keypad, LCD display and status LEDs.

The front panel layout is shown in Figure 4-1, showing the location and labeling of the front panel. The front panel is divided into four functional areas: the LCD Front Panel Display, the Cursor Control Arrow Keys, the Numeric Keypad, and the Front Panel LED Indicators, each described below in Table 4-1.

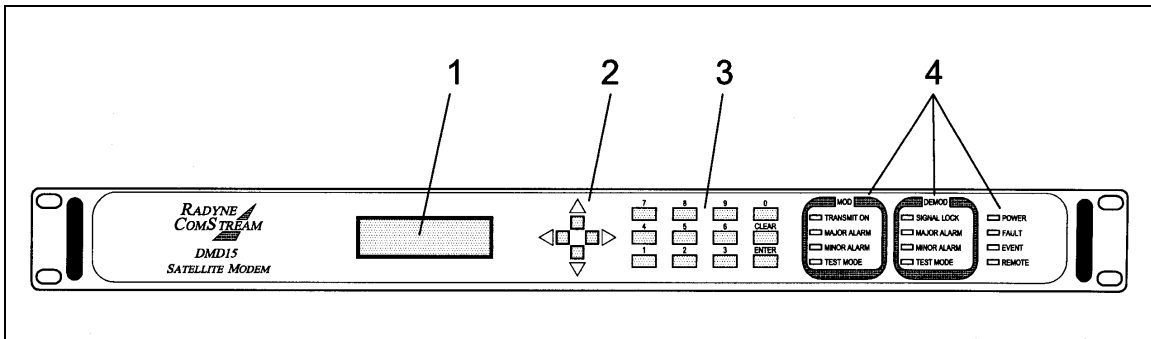

Figure 4-1. DMD15/DMD15L Front Panel

Item Number	Description	Function
1	LCD Front Panel Display	Displays DMD15/DMD15L Operating parameters and Configuration data
2	Cursor Control Arrow Keys	Controls the up, down, right and left motion of the cursor in the LCD Display window
3	Numeric Keypad	Allows entry of numeric data and Clear and Enter function keys
4	Front Panel LED Indicators	See Paragraph 4.1.2 below for an itemized description of these LEDs

4.1.1 LCD Front Panel Display

The front panel display is a 2 line by 16-character LCD display. The display is lighted and the brightness can be set to increase when the front panel is currently in use. The LCD display automatically dims after a period of inactivity. The display has two distinct areas showing current information. The upper area shows the current parameter being monitored, such as 'Frequency' or 'Data Rate'. The lower line shows the current value of that parameter. The LCD display is a single entry window into the large matrix of parameters that can be monitored and set from the Front Panel.

4.1.2 Cursor Control Arrow Keys

A set of 'Arrow' or 'Cursor' keys (\uparrow), (\downarrow), (\rightarrow), (\leftarrow), is used to navigate the parameter currently being monitored or controlled. Table 4-2 describes the functions available at the Front Panel.

4.1.3 Numeric Keypad

A 10 Key Numeric Keypad with 2 additional keys for the 'Enter' and 'Clear' function allows the entry of data into the system. Table 4-2 describes the functions available at the Front Panel.

Table 4-2.							
Edit Mode Key Functions (Front Panel Only)							
Parameter Type	0 – 9	\uparrow	\downarrow	\leftarrow	\rightarrow	'Clear' & \leftarrow	'Clear' & \rightarrow
Fixed Point Decimal	Changes Digit	Toggles \pm (If Signed)	Toggles \pm (If Signed)	Moves Cursor 1 Position Left	Moves Cursor 1 Position Right	N/A	N/A
Unsigned Hexadecimal	Changes Digit	Increments Digit Value	Decrements Digit Value	Moves Cursor 1 Position Left	Moves Cursor 1 Position Right	N/A	N/A
Enumerated	N/A	Previous Value in List	Next Value in List	N/A	N/A	N/A	N/A
Date/ Time	Changes Digit	N/A	N/A	Moves Cursor 1 Position Left	Moves Cursor 1 Position Right	N/A	N/A
IP Address	Changes Digit	Increments Digit Value	Decrements Digit Value	Moves Cursor 1 Position Left	Moves Cursor 1 Position Right	N/A	N/A
Text Strings	Changes Character	Increments Character Value	Decrements Character Value	Moves Cursor 1 Position Left	Moves Cursor 1 Position Right	Clears to Left of Cursor Inclusive	Clears to Right of Cursor Inclusive

4.1.4 Front Panel LED Indicators

Eight LEDs on the DMD15/DMD15L Front Panel (Refer to Table 4-3) indicate the status of DMD15/DMD15L operation. The LED colors maintain a consistent meaning. Green signifies that the indication is appropriate for normal operation, Yellow means that there is a condition not proper for normal operation, and Red indicates a fault condition that will result in lost communications.

Table 4-3.		
LED	Color	Function
Modem LED Indicators		
Power	Green	Indicates that the unit is turned on.
Fault	Red	Indicates a hardware fault for the unit.
Event	Yellow	Indicates that a condition or event has occurred that the modem has stored in memory. The events may be viewed from the Front Panel or in the Terminal Mode.
Remote	Green	Indicates that the unit is set to respond to the remote control input.
Demodulator LED Indicators		
Signal Lock	Green	Indicates that the receiver locked to an incoming carrier and data, including FEC Sync.
Major Alarm	Red	Indicates that the Receive Direction has failed, losing traffic.
Minor Alarm	Yellow	Indicates that a Receive Warning Condition exists.
Test Mode	Yellow	Indicates that the receiver is involved in a current Test Mode activity.
Modulator LED Indicators		
Transmit ON	Green	Indicates that the transmitter is on.
Major Alarm	Red	Indicates that the terrestrial data and/or clock is not being supplied to the unit.
Minor Alarm	Yellow	Indicates that a Transmit Warning Condition exists.
Test Mode	Yellow	Indicates that the transmitter is involved in a current Test Mode activity.

4.2 Parameter Setup

The four Cursor Control Arrow Keys are used to navigate the menu tree and select the parameter to be set. After arriving at a parameter that needs to be modified, depress <ENTER>. The first space of the modifiable parameter highlights (blinks) and is ready for a new parameter to be entered. After entering the new parameter using the keypad (Refer to Figure 4-2), depress <ENTER> to lock in the new parameter. If a change needs to be made prior to pressing <ENTER>, depress <CLEAR> and the display defaults back to the original parameter. Depress <ENTER> again and re-enter the new parameters followed by <ENTER>.

Following a valid input, the DMD15/DMD15L will place the new setting into the nonvolatile EEPROM making it available immediately and available the next time the unit is powered-up.'

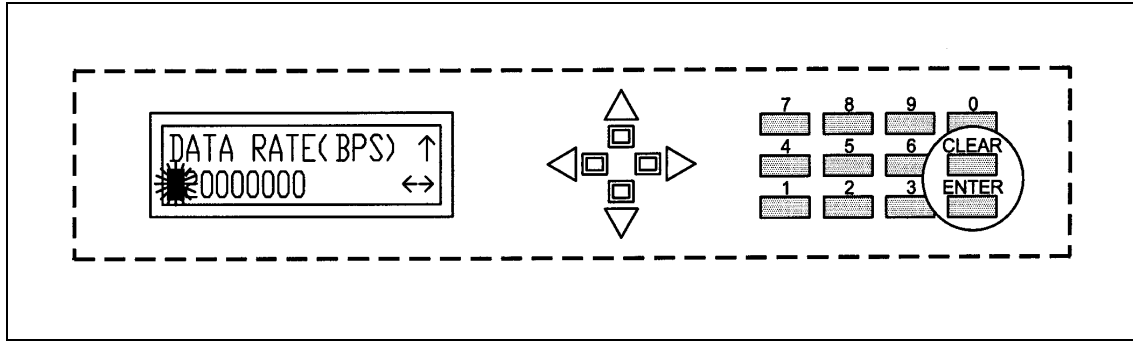

Figure 4-2. Entering New Parameters

4.3 Front Panel Control Screen Menus

The DMD15/DMD15L Front Panel Control Screens are broken down into sections under several Main Menus.

4.3.1 Main Menus

Modulator

Demodulator

Interface

Monitor

Alarms

System

Test

4.3.2 Modulator Menu Options and Parameters

Mode: {IDR, IBS, Closed Net, Drop & Insert}

Used with IDR, or IBS Interface Only.

The Mode Command sets a number of parameters within the modem to meet a set specification. The purpose is to eliminate keystrokes and potential compatibility problems.

Additionally, data rates not covered by the given mode of operation will not be allowed. If the mode of operation is selected after the data rate has been entered, then the data rate must be compatible with the desired mode of operation or the mode will not be allowed. The following parameters are set for the given mode of operation and

cannot be changed while the unit is in the given mode of operation:

IDR Mode:

(IESS-308)

For Data rates 1.544, 2.048, 6.312, 8.448 Mbps

Framing Type: 96 Kbps (IDR)
Scrambler Type: V.35
Spectrum Mask: Intelsat

For Data Rates < 1.544

Framing Type: 1/15 (IBS)
Scrambler Type: IESS-309
Spectrum Mask: Intelsat

IBS Mode:

(IESS-309)

For Data Rates \leq 2048

Framing Type: 1/15 (IBS)
Scrambler Type: IESS-309
Spectrum Mask: Intelsat

Closed Net:

All possible combinations allowed. Activates the AUPC Menu.

Drop & Insert:

Data Rates: n x 64 n = 1, 2, 3, 4, 5, 6, 8,
10, 12, 15, 16, 20, 24, 30
Framing Type: 1/15 (IBS)
Scrambler Type: IESS-309
Spectrum Mask: Intelsat

Strap Code:**{Refer to Strap Code Guide, Table 4-4}**

The Strap Code is a quick set key that sets many modem parameters. Consult the strap code guide for available strap codes. Parameters set by strap code:

Data Rate
Code Rate
Mode
Frame Type
Scrambler Type
Spectrum Mask

Mod IF (menu):**Frequency:**

{50 – 90 MHz, 100 – 180 MHz, or 950 – 1750 MHz (L-Band)}

Allows the user to enter the Modulator IF Frequency in 1 Hz increments.

Power:

{+5 to –20 dBm} {-5 to –30 L-Band}

Allows the user to enter the Transmitter Power Level. The DMD15 has a digital/analog crossover point at -7.4 to -7.5 dBm (-17.4 to -17.5 dBm L-Band) when the output power level setting crosses this threshold, the modulator may glitch and undershoot the output momentarily.

Carrier Ctrl:

{On, Off}

The DMD15 transmitter will turn off the carrier output automatically when the modem determines there is a major alarm. This is done to prevent the carrier from outputting an unknown spectrum and possibly disturbing adjacent carriers. This automatic drop of the carrier can be overridden by masking the alarm that is causing the fault. This will keep the modulator output spectrum transmitting, even when the fault occurs.

Spectrum Inv:

{Normal, Inverted}

Allows the user to invert the direction of rotation for PSK Modulation. Normal meets the IESS Specification.

Modulation:

{QPSK, BPSK, OQPSK, 8PSK, 16QAM}

Allows the user to select the modulation type.

Spectrl Msk:

{Intelsat}

Allows the user to set the spectral shape of Tx Data Filter.

Mod Data (menu):

Data Rate:	{Refer to Technical Specs for Data Rates} Allows the user to set the Data Rate in bps steps via the Front Panel Arrows or Keypad.
Symbol Rate:	Allows the user to view the Symbol Rate.
Conv Enc:	{1/2 Rate VIT, 3/4 Rate VIT, 7/8 Rate VIT, Optional encoders: 1/2 Rate SEQ, 3/4 Rate SEQ, 7/8 Rate SEQ, 2/3 Rate TRE (8PSK), Turbo (.793), Turbo (.495), 3/4 Rate CSC} Allows the user to select the Tx Code Rate and Type.
Diff Encode:	{On, Off, EF Mode*} Allows the user to enable or disable the Differential Encoder. Having the encoder enabled ensures proper phase lock. *EF Mode is a special differential encoder mode that allows compatibility with certain modems when configured in QPSK modulation, and uncoded FEC.
Scrambl Sel:	{None, V.35-IESS, V.35 CITT, V.35 EF, IBS, CCITT, V.35FC, OM73, V.35EF_RS, TPC SCRAMBLER(Turbo Codec)} Allows the user to select the scrambler type.
Scrambl Ctrl:	Allows the user to enable or disable scrambler operation.
Mod Framing:	{1/15 (IBS), 1/15 (Async), 96 Kbps (IDR), None} <i>Used with IDR, IBS, or Asynchronous Interface Only.</i> Allows the user to select the framing type.
Data Invert:	{Terr, Base, Terr & Base} Allows the user to invert the Tx Data polarity.
Symbol Pair:	{None, Swapped} Allows the user to swap the I&Q Channels. (BPSK Mode Only)

Reed-Solomon (menu):

These selections are visible only when the Reed-Solomon Option is installed.

Enable/Disable	{Enable, Disable} Allows the user to Enable/Disable the Reed-Solomon Encoder.
RS Codes	{Refer to Appendix A for valid n/k values} Displays the currently used n, k Reed-Solomon Codes. In Closed Net Mode, the user may select custom RS Codes.
RS Depth	{4, 8} Allows the user to select the Reed-Solomon interleaver depth. In Closed Net Mode, a depth of 4 or 8 may be selected.

4.3.3 Demodulator Menu Options and Parameters

Mode:

**{IDR, IBS, Closed Net, Drop & Insert}
Used with IDR, or IBS Interface Only.**

The Mode Command sets a number of parameters within the modem to meet a set specification. The purpose is to eliminate keystrokes and potential compatibility problems. Additionally, data rates not covered by the given mode of operation will not be allowed. If the mode of operation is selected after the data rate has been entered, then the data rate must be compatible with the desired mode of operation or the mode will not be allowed. The following parameters are set for the given mode of operation and cannot be changed while the unit is in the given mode of operation:

IDR Mode:

(IESS-308)

For Data rates 1.544, 2.048, 6.312, 8.448 Mbps

Framing Type: 96 Kbps (IDR)

Descrambler type: V.35

Spectrum Mask: Intelsat

For Data Rates < 1.544 Mbps

Framing Type: 1/15 (IBS)

Descrambler Type: IESS-309

Spectrum Mask: Intelsat

IBS Mode:

(IESS-309)

For Data Rates \leq 2.048 Mbps

Framing Type: 1/15 (IBS)

Descrambler Type: IESS-309

Spectrum Mask: Intelsat

Closed Net:

All possible combinations allowed

Drop & Insert:

Data Rates: $n \times 64$, $n = 1, 2, 3, 4, 5, 6, 8, 10, 12, 15, 16, 20, 24, 30$

Framing Type: 1/15 (IBS)

Descrambler Type: IESS-309

Spectrum Mask: Intelsat

Strap Code:

{Refer to Strap Code Guide, Section 4.3, Table 4-4}

The Strap Code is a quick set key that sets many modem parameters. Consult the strap code guide for available strap codes. Parameters set by strap code:

Data Rate

Code Rate

Mode

Frame Type

Scrambler Type

Spectrum Mask

Demod IF (menu):

Frequency:	{50 – 90 MHz, 100 – 180 MHz, or 950 – 1750 MHz (L-Band)} Allows the user to enter the Modulator IF Frequency in 1 Hz increments.
Spectrum Inv:	{Normal, Inverted} Allows the user to invert the direction of rotation for PSK Modulation. Normal meets the IESS Specification.
Demodulation:	{QPSK, BPSK, OQPSK, 8PSK, 16QAM} Allows the user to select the demodulation type.
Spectrl Msk:	{Intelsat} Allows the user to set the spectral shape of Tx Data Filter.
Swp Bound:	{±0 – 32 kHz} Allows the user to set the acquisition range for the demodulator
Swp Delay:	{0.0 – 900.0 sec} Allows the user to set the reacquisition delay time in 1/10 th second increments. (See section 3.24 for a complete description of the DMD15/DMD15L reacquisition.
ReAcq Sweep:	{0 – 32000 Hz} Allows the user to set the reacquisition sweep in 1 Hertz increments. (See section 3.24 for a complete description of the DMD15/DMD15L reacquisition.

Demod Data (menu):

Data Rate:	{Refer to Technical Specs for Data Rates} Allows the user to set the Data Rate in bps steps via the Front Panel Arrows or Keypad.
Symbol Rate:	Allows the user to view the Symbol Rate.
Conv Dec:	{1/2 Rate VIT, 3/4 Rate VIT, 7/8 Rate VIT, Optional encoders 1/2 Rate SEQ, 3/4 Rate SEQ , 7/8 Rate SEQ , 2/3 Rate TRE (8PSK), Turbo (.793), Turbo (.495), 3/4 Rate CSC} Allows the user to select the Tx Code Rate and Type.
Diff Decode:	{On, Off, EF Mode*} Allows the user to enable or disable the Differential Decoder. Having the decoder enabled ensures proper phase lock. *EF Mode is a special differential decoder mode that allows compatibility with certain modems when configured in QPSK modulation, and uncoded FEC.
Dscrmbl Sel:	{None, V.35-IESS, V.35 CITT, V.35 EF, IBS, CCITT, V.35FC, OM73, V.35EF_RS, TPC SCRAMBLER (Turbo Codec)} Allows the user to select the descrambler type.
Dscrmbl Ctrl	{On, Off} Allows the user to enable or disable the descrambler operation.
Dmd Framing:	{1/15 (IBS), 1/15 (Async), 96 Kbps (IDR), None} <i>Used with IDR, IBS, or Asynchronous Interface Only.</i> Allows the user to select the Framing Type.
Data Invert:	{Terr, Base, Terr & Base} Allows the user to invert the Rx Data polarity.
Symbol Pair:	{None, Swapped} Allows the user to swap the I&Q Channels. (BPSK Mode Only)

<u>Reed-Solomon (menu):</u>	These selections are visible only when the Reed-Solomon Option is installed.
Enable/Disable	{Enable, Disable} Allows the user to Enable/Disable the Reed-Solomon Encoder.
RS Codes	{Refer to Appendix A for valid n/k values} Displays the currently used n, k Reed-Solomon Codes. In Closed Net Mode, the user may select custom RS Codes.
RS Depth	{4, 8} Allows the user to select the Reed-Solomon interleaver depth. In Closed Net Mode, a depth of 4 or 8 may be selected.

4.3.4 Interface Menu Options and Parameters

Tx Setup (menu):

Tx Ckt ID:	Allows the user entry of a Tx Circuit Identifier. Circuits can be given up to an 11 Character alphanumeric identity such as LINK1.
Tx Type:	{G.703, V.35, RS-232, RS-422} Allows the user to select the Transmit Type.
Tx Clock:	{SCTE (External), SCT (Internal), SCR, EXT CLK} Allows the user to select the Transmit Clock Source.
Clk Polarity:	{Auto, Normal, Inverted} Allows the user to select the Clock Polarity for the Tx Terrestrial Clock relative to the Tx Data. "Auto" detects wrong polarity and automatically corrects. If G.703 Interface is selected, this selection cannot be changed.
SCT Source:	{INTERNAL (SCT), SCR (Rx SAT CLK)} Allows the user to select SCT Source to be either the SCT Oscillator or RX Satellite Clock. Rx SAT CLK is used for loop timing.
ESC CH#1	{+10 to -20} Available only in IDR Mode at a valid IDR Rate. Controls the volume of the ESC Channels.
ESC CH#2	See above.

Tx D&I (menu):

Drop Mode:	{Enable, Disable} Allows the user to enable or disable the following: T1-D4, T1-ESF, PCM-30, PCM-30C, PCM-31, PCM-31C, SLC-96, T1-D4-S, T1-ESF-S.
Map Copy:	{Rx Edit, Tx Edit, Rx Acti, Tx Acti, ROM 1...ROM 8, User 1...User 8} Allows user to copy Drop and Insert maps. If the user attempts an invalid copy, the error prompt "BAD DESTINATION" will be displayed and the copy will not be allowed. The Tx Active map is the drop map currently being used by the modem. For a more detailed description of this function, see Section 4.6.4.
SATCh TS:	Allows the user to edit the Tx Edit Map to specify the terrestrial slots that will be dropped into which satellite channels. The Satellite Channels are fixed and the number of channels are determined by the data rate. The Terrestrial Timeslots available are determined by the Drop Mode. When the user has finished editing the Tx Edit map, it must be copied to the Tx Active map before it can be used by the modem.
Time Mark:	{Enable, Disable} Allows the user to enable or disable the "Time Mark Transfer" (TMT) Transmit Request External Input to initialize the state machine that detects the proper states of I and Q and inserts the TMT Pattern into the transmit symbol stream. This feature is only available in BPSK, QPSK, and OQPSK Modulations and requires specific hardware and configuration at the factory.
TMT Length:	{4, 5, 6, 7, 8, 9, 10, 11, 12, 13, 14, 15, 16} Allows the user to set the length of the pattern marker. This feature is only available in BPSK, QPSK, and OQPSK Modulations and requires specific hardware and configuration at the factory.

Rx Setup (menu):

Rx Ckt ID:	Provides entry of Rx Circuit Identifier. Circuits can be given up to an 11 Character alphanumeric Identity such as DLINK1
Rx Type:	{G.703 (Balanced/Unbalanced), V.35, RS-232, RS-422} Allows the user to select the Receive Type.
Buff Size:	{0-32 msecs} Allows the user to set the Doppler Buffer Size in msec.
Buff Clk:	{SCTE (External), SCT (Internal), Rx Sat, EXTCLK}

Allows the user to select the buffer clock source. Must set Buff size to zero to bypass.

Clk Polarity:**{Normal, Inverted}**

Allows the user to select the Buffer Clock Polarity for the Tx Terrestrial Clock relative to the Tx Data. If G.703 Interface is selected, this selection cannot be changed.

Rx D&I (menu):**Insert Mode:****{Enable, Disable}**

Allows the user to enable or disable the following: T1-D4, T1-ESF, PCM-30, PCM-30C, PCM-31, PCM-31C, SLC-96, T1-D4-S, T1-ESF-S.

T1E1 Frm Src**{Internal, External}**

Selects frame source for T1 or E1 framing.

Map Copy:**{Rx Edit, Tx Edit, Rx Acti, Tx Acti, ROM 1...ROM 8, User 1...User 8}**

Allows user to copy Drop and Insert maps. If the user attempts an invalid copy, the error prompt "BAD DESTINATION" will be displayed and the copy will not be allowed. The Rx Active map is the drop map currently being used by the modem. For a more detailed description of this function, see Section 4.6.4.

SATCh TS:

Allows the user to edit the Tx Edit Map to specify the terrestrial slots that will be dropped into which satellite channels. The Satellite Channels are fixed and the number of channels is determined by the data rate. The Terrestrial Timeslots available are determined by the Drop Mode. When the user has finished editing the Tx Edit map, it must be copied to the Tx Active map before it can be used by the modem.

TMT Length:**{4, 5, 6, 7, 8, 9, 10, 11, 12, 13, 14, 15, 16}**

Allows the user to set the length of the pattern marker. This feature is only available in BPSK, QPSK, and OQPSK Modulations and requires specific hardware and configuration at the factory.

General:**Freq Ref Src:****{Internal, External, High Stability}**

Allows the user to select the Frequency Reference Source.

Async (menu):**ES Mode:****{Normal, Enhanced (option)}**

Allows user to choose between Normal and Enhanced Async Mode if the enhanced option is available.

ES Interface:**{RS-232, RS-485}**

Allows user to select between RS-232 or -485

ES Baud:	{150-19200} Allows the user to select the baud rate in Enhanced Async mode. Available rates are listed in Sect 3.20.1
ES Data Bits:	{7,8} Allows the user to choose between 7 or 8 bit data.

4.3.5 AUPC Menu Options and Parameters

Note: *AUPC Menus are only available when the Modulator is in 'Closed Net' Mode and Framing is 'EFAUPC 1/15'.*

<u>Local AUPC (menu):</u>	The 'LOCAL AUPC CONFIGURATION' Menu contains the local configuration parameters for the AUPC Function.
AUPC Enable:	{Off, On} Allows the user to enable or disable the Local AUPC Function of the local modem. The Local AUPC Function is the response to the commands for an increase or decrease of the Transmit Power in 0.5 dB steps. The command to change to the setting is indicated in the 'REMOTE CL ACTION' Menu upon receiver loss of lock of the remote modem.
Nominal TX Power:	{variable through power range} Allows the user to set the nominal Transmit Power. The nominal Transmit Power is the setting that will be used when the remote modem indicates that its receiver has lost lock and commands a change to the setting indicated in the 'REMOTE CL ACTION' Menu. That change will only be implemented if the 'REMOTE CL ACTION' Menu is set to "NOMINAL".
Minimum TX Power:	{variable through power range} Allows the user to set the minimum Transmit Power. The minimum Transmit Power is the lowest power setting that will be used when the remote modem commands a decrease of the Transmit Power.
Maximum TX Power:	{variable through power range} Allows the user to set the maximum Transmit Power. The maximum Transmit Power is the highest power setting that will be used when the remote modem commands an increase of the Transmit Power. It is the setting that will be used when the remote modem indicates that its receiver has lost lock and commands a change to the setting indicated in the 'REMOTE CL ACTION', Menu. That change will only be implemented if the 'REMOTE CL ACTION' Menu is set to "MAXIMUM".
Target Eb/No:	{variable} Allows the user to set the desired E_b/N_o for the local receiver. This setting is compared against the receive

E_b/N_0 and commands to the remote modem to increase or decrease Transmit Power accordingly are sent.

Tracking Rate:**{0.5 to 6.0}**

Allows the user to set the rate at which the commands to increase or decrease Transmit Power are sent. Each command will result in a 0.5-dB increase or decrease in Transmit Power from the remote transmitter. The tracking rate is adjustable from 0.5 dB per minute to 6.0 dB per minute in 0.5 dB steps. The resulting 'command rate' is 1 command every minute to 1 command every five seconds.

Local CL Action:**{HOLD, NOMINAL, MAXIMUM}**

Allows the user to set the Transmit Power Setting to be used when the local modem receiver loses lock. The setting can be 'HOLD' (no action taken), 'NOMINAL' (the nominal Transmit Power Setting is used), and 'MAXIMUM' (the maximum Transmit Power Setting is used).

Remote CL Action:**{HOLD, NOMINAL, MAXIMUM}**

Allows the user to set the Transmit Power Setting to be used when the remote modem receiver loses lock. The setting can be 'HOLD' (no action taken), 'NOMINAL' (the nominal Transmit Power Setting is used), and 'MAXIMUM' (the maximum Transmit Power Setting is used).

<u>Remote AUPC (menu):</u>	The 'REMOTE AUPC CONFIGURATION' menu contains the remote configuration parameters for the AUPC Function.
AUPC Enable:	{OFF, ON} Allows the user to enable or disable the AUPC Function of the remote modem. The remote AUPC Function is the response of the local modem to commands for an increase or decrease of the Transmit Power in 0.5 dB steps and the command to change to the setting indicated in the 'REMOTE CL ACTION' menu of the remote modem upon receiver loss of lock.
Loopback:	Allows the user to enable or disable the Baseband Loopback Test Mode of the remote modem.
TX 2047 Pattern:	Allows the user to enable or disable the Transmit 2047 Pattern Test Mode of the remote modem.
<u>Remote AUPC Monitor:</u>	The 'REMOTE AUPC MONITOR' Menu contains the remote monitor status for the AUPC Function.
Remote 2047 BER:	Reports the BER measurement of the receiver 2047 Pattern Test Mode of the remote modem. BER is reported from the 1×10^{-5} to 1×10^{-7} in tenth decade steps. If the pattern does not synchronize or is out of range, 'NO DATA' will be displayed.

4.3.6 Monitor Menu Options and Parameters

Level:	Displays the estimated receive signal level as seen by the Demodulator.
Eb/No:	Displays the estimated E_b/N_o as seen by the demodulator.
SER:	Displays the estimated channel error rate (before decoding) measured by the modem.
CBER:	Displays the estimated corrected bit error rate (after decoding).
Error Count:	Displays the current error count from the Viterbi Decoder.
Offset Freq:	Displays the received carrier frequency offset as measured by the modem.

Event Buff:	Displays a history of events recorded in the event buffer. A maximum of 40 events may be stored in the buffer. Upon receipt of the 41 st event, the first received event is automatically deleted, and so on, maintaining the maximum 40 events.
Press Clr to Erase Events:	Clears the contents of the Event Buffer.
<u>Voltages (menu):</u>	
+5 Volt:	Displays the measured voltage of the +5 Volt power bus located inside the modem.
+12 Volt:	Displays the measured voltage of the +12 Volt power bus located inside the modem.
-12 Volt:	Displays the measured voltage of the -12 Volt power bus located inside the modem.
Buffer:	Displays the status of the Doppler Buffer from 0 to 100%.
Press Clr to Center Buffer:	Causes Doppler Buffer to re-center.
BER Exponent:	{6 - 9} Allows the user to set the time base for the Channel Error Rate Measurement, used to estimate E_b/N_0 .

4.3.7 Alarms Menu Options and Parameters

Active Alrms (menu):



Masking alarms may cause undesirable modem performance.

<u>Major Tx (menu):</u>	<u>Status</u> <u>Edit Table</u>
TxuProc Mask:	{Pass/Fail, No/Yes} Indicates a Hardware Transmit or DSP Failure within the modem. (Yes = Masked, No = Unmasked)
TxPower Mask:	{Pass/Fail, No/Yes} Indicates that the Modem Tx Output Power is within allowed tolerance. A solid indication indicates a hardware or programming failure within the modem.
TxOSClk Mask:	{Pass/Fail, No/Yes} Indicates that the TX Oversample Clock PLL is not locked. This alarm will flash on during certain modem

parameter changes. A solid indication indicates a hardware or programming failure within the modem.

CompClk Mask: {Pass/Fail, No/Yes}
Indicates that Tx Composite Clock PLL is not locked. This alarm will flash on during certain modem parameter changes. A solid indication indicates a problem with the incoming clock to the modem (SCTE).

TxSynth Mask: {Pass/Fail, No/Yes}
Indicates that the Tx IF Synthesizer is not locked. This alarm will flash on during certain modem parameter changes. A solid indication indicates a hardware or programming failure within the modem.

Major Rx (menu):

RxuProc Mask: {Pass/Fail, No/Yes}
Indicates a hardware failure within the modem.

SigLoss Mask: {Pass/Fail, No/Yes}
Indicates that the demod is unable to lock to a signal.

MfrSync Mask: {Pass/Fail, No/Yes}
Indicates that the Framing Unit is unable to find the expected framing pattern.

FrmSync Mask: {Pass/Fail, No/Yes}
Indicates that the Framing Unit is unable to find the expected framing pattern.

IF Syn Lock: {Pass/Fail, No/Yes}
Indicates the Rx IF Synthesizer is not locked. This alarm will flash ON during certain modem parameter changes. A solid indication indicates a hardware or programming failure within the modem.

Rx Ovrsmpl Lk: {Pass/Fail, No/Yes}
Indicates that the RX Oversample Clock PLL is not locked. This alarm will flash on during certain modem parameter changes. A solid indication indicates a hardware or programming failure within the modem.

Buf Clk Lock: {Pass/Fail, No/Yes}
Indicates that the Buffer Clock PLL is not locked. This alarm will flash ON during certain modem parameter changes. A solid indication indicates a problem with the Receive Buffer Clock.

Minor Tx (menu):

Tx Activity (menu):

TerrClk Mask:	{Pass/Fail, No/Yes} Indicates no Terrestrial Clock activity.
IntClk Mask:	{Pass/Fail, No/Yes} Indicates no SCT Clock activity.
TxSatCk Mask:	{Pass/Fail, No/Yes} Indicates no Tx Sat Clock activity.
Tx Data Mask:	{Pass/Fail, No/Yes} Indicates no Tx Data activity.
TerrAIS Mask:	{Pass/Fail, No/Yes} Indicates that AIS has been detected in the Tx Data Stream.

Drop Alarms (menu):

Frm Lock:	{Pass/Fail, No/Yes} Indicates if drop/insert data is frame locked.
Multiframe Lock:	{Pass/Fail, No/Yes} Indicates if drop/insert data has multiframe lock.
CRC Lock:	{Pass/Fail, No/Yes} Indicates if the Circular Redundancy Check is passing in PCM30C and PCM31C Mode.

RS FIFO: **{Pass/Fail, No/Yes}**
Indicates status of the Tx Reed-Solomon FIFO.

FllBack: **{Pass/Fail, No/Yes}**
Indicates Tx clock fallback.

Minor Rx (menu):

BufUFLw Mask: **{Pass/Fail, No/Yes}**
Indicates that a Doppler Buffer underflow has occurred.

BufOFLw Mask: **{Pass/Fail, No/Yes}**
Indicates that a Doppler Buffer overflow has occurred.

Buf <10% Mask: **{Pass/Fail, No/Yes}**
Indicates that the Doppler Buffer is about to underflow.

Buf >90% Mask: **{Pass/Fail, No/Yes}**
Indicates that the Doppler Buffer is about to overflow.

Viterbi Lock: **{Pass/Fail, No/Yes}**
Indicates that the Viterbi Decoder is not locked.

Eb/No Mask: **{Pass/Fail, No, Yes}**
Indicates that the calculated Eb/No of the incoming signal has fallen below the programmed threshold value.

Rx Activity (menu):

Buf Clk Mask:	{Pass/Fail, No/Yes} Indicates that the selected buffer clock source is not active.
Rx Sat Mask:	{Pass/Fail, No/Yes} Indicates that the Rx Sat buffer clock source is not active.
Insert Mask:	{Pass/Fail, No/Yes} Indicates that the Insert buffer clock source is not active.
RX Data Mask:	{Pass/Fail, No/Yes}
SatAIS Mask:	{Pass/Fail, No/Yes}

Insert Alarms (menu):

Frm Lock Mask:	{Pass/Fail, No/Yes}
Multiframe Lock:	{Pass/Fail, No/Yes}
CRC Lock Mask:	{Pass/Fail, No/Yes}
T1 Signaling:	{Pass/Fail, No/Yes}

Rx RS Faults (menu):

Dec Lock Mask:	{Pass/Fail, No/Yes} Indicates status of the Reed-Solomon Decoder Lock
Dintlvr Mask:	{Pass/Fail, No/Yes} Indicates status of the Reed-Solomon de-interleaver word fault
UnCWord Mask:	{Pass/Fail, No/Yes} Indicates status of the Reed-Solomon uncoded word fault.

IBS BER Mask: **{Pass/Fail, No/Yes}**
Indicates that more than 1 bit in 1000 is in error in IBS Mode.

RxLvl Mask: **{Pass/Fail, No/Yes}**
Indicates if Rx level is below allowable limits.

Fillback Mask: **{Pass/Fail, No/Yes}**
Indicates Rx Clock fallback.

Common (menu):

-12 Power: **{Pass/Fail, No/Yes}**
Indicates power supply voltage out of range.

+12 Power:	{Pass/Fail, No/Yes} Indicates power supply voltage out of range.
+5 Power:	{Pass/Fail, No/Yes} Indicates power supply voltage out of range.
Battery:	{Pass/Fail, No/Yes} Indicates that internal clock battery is low.
RAM/ROM:	{Pass/Fail, No/Yes} Indicates M&C memory fault.
M&C uProc:	{Pass/Fail, No/Yes} Indicates M&C Microprocessor hardware failure.
UIO Present:	{Pass/Fail, No/Yes} Indicates absence of Universal Input/Output Module (UIM) Hardware
IF Present:	{Pass/Fail, No/Yes} Indicates absence of IF hardware detect.
Ext Ref Lock:	{Pass/Fail, No/Yes} Indicates that the External Reference PLL is not locked.
Ext EXC Act:	{Pass/Fail, No/Yes} Indicates that the External Clock is not active.

Ext Ref Mask: {Pass/Fail, No/Yes}
Indicates no activity on the External Reference.

HiStab Mask: {Pass/Fail, No/Yes}
Indicates if High Stability Oscillator is active.

Latched Alarm (menu): The following alarms are latched in order to catch intermittent failures:

Note: Refer to Section 4.2.7, “Active Alrms (menu)” for an explanation of these Menu Options and Parameters.

Major Tx (menu):

TxuProc:

TxPower:

TxOSCik:

CompClk:

TxSynth:

Major Rx (menu):

RxuProc:

SigLoss:

MfrSync:

FrmSync:

IBS BER:

RxIFSynLock:

RxOSPLLLock:

Buf Clk Lock:

Minor Tx (menu): There are currently no Latched Minor Tx alarms.

Minor Rx (menu):**RxBuf Alarms (menu):**

BufUFlw:

BufOFLw:

Buf<10%:

Buf>90%:

Rx Activity (menu):

RxSat:

RxData:

SatAIS:

InsClk:

Common (menu):

-12 Power:

+12 Power:

+5 Power:

Battery:

RAM/ROM:

M&C uProc:

Ext Ref Lock:

Backward Alr (menu):

Backward alarms are alarms that are fed back to or received from the other end of the satellite link. In IBS Mode (including Drop & Insert), Backward Alarm 1 is the only one used. It would be received if the distant end demod drops lock.

Backward 1: {Rcv = yes/no, Force = yes/no}**Backward 2:** {Rcv = yes/no, Force = yes/no}**Backward 3:** {Rcv = yes/no, Force = yes/no}**Backward 4:** {Rcv = yes/no, Force = yes/no}**DIYellow:** {Force = yes/no}**MapSummaryTo (menu):****Backward 1:** {Xmt = no/yes}

Backward 2: {Xmt = no/yes}

Backward 3: {Xmt = no/yes}

Backward 4: {Xmt = no/yes}

Clear Alarms: Allows the user to reset the latched alarms.

4.3.8 System Menu Options and Parameters

Control Mode: {Front Panel, Terminal, Computer}
Allows the user to select the active control source.

Config Copy Allows settings in Config 1-5 or current settings to be copied into another config slot.

General (menu):

Date: {YY MM DD}
Allows the user to enter the current date.

Time: {HH:MM:SS}
Allows the user to enter the current time.

Backlight (menu):

Level: {High, Low}
Allows the user to enter the backlight intensity level.

Timeout: {00 - 99}
Allows the user to enter the length of time (in seconds) of keyboard inactivity before the backlight shuts off. 00 = no timeout.

Key Click: {On, Off}
Allows the user to enable or disable the audible click heard each time a key is pressed.

Eb/No Alarm Thrsh {0.0 – 9.9 dB}
The EB/No Threshold is a value set by the user to allow the modem to alert thr user, via a demodulator minor alarm, that the Eb/No calculated by the demodulator has reached or exceeded the programmed limit. The modem default value is 0.0 dB.

Radyne DMD15 Version X.X: Modem Version

Firmware Rev (menu):**Interface (menu):****UIO Code:****UIO Xilinx:****M&C:**

Term Baud:	{Same as remote baud listed below} Displays the Terminal Port Baud Rate.
Emulation:	{VT100, ADDS-VP, WYSE 50} Allows the user to select the Terminal Emulation Mode for the Terminal Port.
Remote Addr:	{32 - 255} Allows the user to enter the Remote Port Multidrop Address.
Remote Baud:	{150, 300, 600, 1200, 2400, 4800, 9600, 19200, 38,400} Allows the user to enter the Remote Port Baud Rate.

4.3.9 Test Menu Options and Parameters

2047 Test:	{None, Tx, Rx, Tx/Rx} Allows the user to enable or disable the 2047 Pattern Test. "Tx" enables the transmit pattern generator. "Rx" enables the receive pattern checker. "Tx/Rx" enables both.
Insert Errors:	{0000 - 9999} Allows the user to select the number of errors to insert. Once the number of errors to insert has been selected, pressing 'Enter' twice causes the number of errors shown to be inserted in the data stream.
2047 Errors:	{No Sync, nnnn} Displays the number of errors detected by the 2047 Pattern checker.
2047 BER:	{No Sync, nnnn x 10⁻⁹} Displays the measured BER for the 2047 Pattern.
Clear 2047:	{Ent = Y, Clr = N} Restarts 2047 BER Test.

<u>Loopbacks:</u>	Terrestrial Loopback is performed at the Terrestrial Interface
IF:	IF loopback loops the IF output of the Modulator to the IF input of the Demodulator. If using 8PSK or 16QAM modulation the output power must be above –15 dB.
Tx Terr:	Sends Tx Terrestrial Data to Rx data out.
Rx Terr:	(Distant Loop) Sends received satellite data to the Modulator for transmission to the distant end.
Tx/Rx Terr:	Enables both. Baseband loopback is performed at interface between the Baseband Processor Card and the Modem Card. This ensures Framer/Deframer integrity.
Tx BB:	Sends Tx data to the receive input to the BB Card.
Rx BB:	Sends Rx data from the Modem Card to the Tx data input to the Modem Card.
Tx/RX BB:	Enables both.

Carrier:

CW:	Causes the Modulator to output a pure carrier.
Dual:	Causes a double sideband output.
Offset:	Causes a single sideband output.
Normal:	Causes the Modulator to output normal modulation.
Pos Fir:	For manufacturer's use only.
Neg Fir:	For manufacturer's use only.

4.4 DMD15/DMD15L Strap Codes

The Strap Code is a quick set key that sets many of the modem parameters. For quick setup of the DMD15/DMD15L, Strap Codes are very helpful. When a Strap Code is entered, the modem is automatically configured for the code's corresponding data rate, overhead, code rate, framing, scrambler type and modulation. An example of how to set a strap code follows:

Example: At the Front Panel <Modulator> Menu, depress '↓', then move '→' to the 'Strap Code' Submenu and enter #16. The DMD15/DMD15L will be automatically configured to the parameters shown below in the highlighted row 'Strap Code 16'.

Use the following Strap Code Guide for available strap codes.

Table 4-4. DMD15/DMD15L Strap Codes								
Strap Code (DEC)	Data Rate (Kbps)	Overhear	Code Rate	Framing	Scrambler	Drop and Insert	Reed-Solomon	Modulation
1	64	16/15	1/2	IBS	IBS	DISABLE	DISABLE	QPSK
2	128	16/15	1/2	IBS	IBS	DISABLE	DISABLE	QPSK
3	256	16/15	1/2	IBS	IBS	DISABLE	DISABLE	QPSK
5	384	16/15	1/2	IBS	IBS	DISABLE	DISABLE	QPSK
6	512	16/15	1/2	IBS	IBS	DISABLE	DISABLE	QPSK
9	768	16/15	1/2	IBS	IBS	DISABLE	DISABLE	QPSK
4	1536	16/15	1/2	IBS	IBS	DISABLE	DISABLE	QPSK
10	1920	16/15	1/2	IBS	IBS	DISABLE	DISABLE	QPSK
8	2048	16/15	1/2	IBS	IBS	DISABLE	DISABLE	QPSK
12	2048	1*	1/2	IBS	IBS	DISABLE	DISABLE	QPSK
16	1544	96K	3/4	IDR	V.35 (IESS)	DISABLE	DISABLE	QPSK
32	2048	96K	3/4	IDR	V.35 (IESS)	DISABLE	DISABLE	QPSK
64	6312	96K	3/4	IDR	V.35 (IESS)	DISABLE	DISABLE	QPSK
128	8448	96K	3/4	IDR	V.35 (IESS)	DISABLE	DISABLE	QPSK
24	56	1	1/2	CNT	V.35 (IESS)	DISABLE	DISABLE	QPSK
33	56	1	3/4	CNT	V.35 (IESS)	DISABLE	DISABLE	QPSK
34	64	1	1/2	CNT	V.35 (IESS)	DISABLE	DISABLE	QPSK
36	64	1	3/4	CNT	V.35 (IESS)	DISABLE	DISABLE	QPSK
40	128	1	1/2	CNT	V.35 (IESS)	DISABLE	DISABLE	QPSK
48	128	1	3/4	CNT	V.35 (IESS)	DISABLE	DISABLE	QPSK
65	256	1	1/2	CNT	V.35 (IESS)	DISABLE	DISABLE	QPSK
66	256	1	3/4	CNT	V.35 (IESS)	DISABLE	DISABLE	QPSK
68	320	1	1/2	CNT	V.35 (IESS)	DISABLE	DISABLE	QPSK
72	320	1	3/4	CNT	V.35 (IESS)	DISABLE	DISABLE	QPSK
80	384	1	1/2	CNT	V.35 (IESS)	DISABLE	DISABLE	QPSK
96	384	1	3/4	CNT	V.35 (IESS)	DISABLE	DISABLE	QPSK
129	512	1	1/2	CNT	V.35 (IESS)	DISABLE	DISABLE	QPSK
130	512	1	3/4	CNT	V.35 (IESS)	DISABLE	DISABLE	QPSK
132	768	1	1/2	CNT	V.35 (IESS)	DISABLE	DISABLE	QPSK
136	768	1	3/4	CNT	V.35 (IESS)	DISABLE	DISABLE	QPSK
144	896	1	1/2	CNT	V.35 (IESS)	DISABLE	DISABLE	QPSK

44	896	1	3/4	CNT	V.35 (IESS)	DISABLE	DISABLE	QPSK
7	1344	1	1/2	CNT	V.35 (IESS)	DISABLE	DISABLE	QPSK
11	1344	1	3/4	CNT	V.35 (IESS)	DISABLE	DISABLE	QPSK
13	1536	1	1/2	CNT	V.35 (IESS)	DISABLE	DISABLE	QPSK
14	1536	1	3/4	CNT	V.35 (IESS)	DISABLE	DISABLE	QPSK
19	1544	1	1/2	CNT	V.35 (IESS)	DISABLE	DISABLE	QPSK
21	1544	1	3/4	CNT	V.35 (IESS)	DISABLE	DISABLE	QPSK
22	1920	1	1/2	CNT	V.35 (IESS)	DISABLE	DISABLE	QPSK
25	1920	1	3/4	CNT	V.35 (IESS)	DISABLE	DISABLE	QPSK
26	2048	1	1/2	CNT	V.35 (IESS)	DISABLE	DISABLE	QPSK
28	2048	1	3/4	CNT	V.35 (IESS)	DISABLE	DISABLE	QPSK
37	2368	1	1/2	CNT	V.35 (IESS)	DISABLE	DISABLE	QPSK
38	2368	1	3/4	CNT	V.35 (IESS)	DISABLE	DISABLE	QPSK
41	48	1	1/2	CNT	V.35 (IESS)	DISABLE	DISABLE	QPSK
160	1544	3072/ 2895	1/2	IBS	IBS	DISABLE	DISABLE	QPSK
52	1920	16/15	3/4	IBS	IBS	DISABLE	DISABLE	QPSK
69	6312	1	3/4	CNT	V.35 (IESS)	DISABLE	DISABLE	QPSK
70	8448	1	3/4	CNT	V.35 (IESS)	DISABLE	DISABLE	QPSK
73	3152	1	1/2	CNT	V.35 (IESS)	DISABLE	DISABLE	QPSK
74	3152	1	3/4	CNT	V.35 (IESS)	DISABLE	DISABLE	QPSK
76	3264	1	1/2	CNT	V.35 (IESS)	DISABLE	DISABLE	QPSK
81	3264	1	3/4	CNT	V.35 (IESS)	DISABLE	DISABLE	QPSK
88	512	16/15	3/4	IBS	IBS	DISABLE	DISABLE	QPSK
97	1024	1	1/2	CNT	V.35 (IESS)	DISABLE	DISABLE	QPSK
98	1024	1	3/4	CNT	V.35 (IESS)	DISABLE	DISABLE	QPSK
112	64	16/15	3/4	IBS	IBS	DISABLE	DISABLE	QPSK
131	128	16/15	3/4	IBS	IBS	DISABLE	DISABLE	QPSK
133	256	16/15	3/4	IBS	IBS	DISABLE	DISABLE	QPSK
134	192	16/15	1/2	IBS	IBS	DISABLE	DISABLE	QPSK
137	192	16/15	3/4	IBS	IBS	DISABLE	DISABLE	QPSK
138	320	16/15	1/2	IBS	IBS	DISABLE	DISABLE	QPSK
140	320	16/15	3/4	IBS	IBS	DISABLE	DISABLE	QPSK
145	384	16/15	3/4	IBS	IBS	DISABLE	DISABLE	QPSK
100	448	16/15	1/2	IBS	IBS	DISABLE	DISABLE	QPSK
146	448	16/15	3/4	IBS	IBS	DISABLE	DISABLE	QPSK

104	576	16/15	1/2	IBS	IBS	DISABLE	DISABLE	QPSK
148	576	16/15	3/4	IBS	IBS	DISABLE	DISABLE	QPSK
152	640	16/15	1/2	IBS	IBS	DISABLE	DISABLE	QPSK
161	640	16/15	3/4	IBS	IBS	DISABLE	DISABLE	QPSK
162	704	16/15	1/2	IBS	IBS	DISABLE	DISABLE	QPSK
164	704	16/15	3/4	IBS	IBS	DISABLE	DISABLE	QPSK
168	768	16/15	3/4	IBS	IBS	DISABLE	DISABLE	QPSK
193	832	16/15	1/2	IBS	IBS	DISABLE	DISABLE	QPSK
194	832	16/15	3/4	IBS	IBS	DISABLE	DISABLE	QPSK
196	896	16/15	1/2	IBS	IBS	DISABLE	DISABLE	QPSK
208	896	16/15	3/4	IBS	IBS	DISABLE	DISABLE	QPSK
224	960	16/15	1/2	IBS	IBS	DISABLE	DISABLE	QPSK
15	960	16/15	3/4	IBS	IBS	DISABLE	DISABLE	QPSK
23	1024	16/15	1/2	IBS	IBS	DISABLE	DISABLE	QPSK
27	1024	16/15	3/4	IBS	IBS	DISABLE	DISABLE	QPSK
29	1536	16/15	3/4	IBS	IBS	DISABLE	DISABLE	QPSK
30	1088	16/15	1/2	IBS	IBS	DISABLE	DISABLE	QPSK
39	1088	16/15	3/4	IBS	IBS	DISABLE	DISABLE	QPSK
43	1152	16/15	1/2	IBS	IBS	DISABLE	DISABLE	QPSK
46	1152	16/15	3/4	IBS	IBS	DISABLE	DISABLE	QPSK
51	1216	16/15	1/2	IBS	IBS	DISABLE	DISABLE	QPSK
53	1216	16/15	3/4	IBS	IBS	DISABLE	DISABLE	QPSK
54	1280	16/15	1/2	IBS	IBS	DISABLE	DISABLE	QPSK
57	1280	16/15	3/4	IBS	IBS	DISABLE	DISABLE	QPSK
58	1344	16/15	1/2	IBS	IBS	DISABLE	DISABLE	QPSK
67	1408	16/15	1/2	IBS	IBS	DISABLE	DISABLE	QPSK
71	1408	16/15	3/4	IBS	IBS	DISABLE	DISABLE	QPSK
75	1472	16/15	1/2	IBS	IBS	DISABLE	DISABLE	QPSK
77	1472	16/15	3/4	IBS	IBS	DISABLE	DISABLE	QPSK
78	1600	16/15	1/2	IBS	IBS	DISABLE	DISABLE	QPSK
83	1600	16/15	3/4	IBS	IBS	DISABLE	DISABLE	QPSK
85	1664	16/15	1/2	IBS	IBS	DISABLE	DISABLE	QPSK
86	1664	16/15	3/4	IBS	IBS	DISABLE	DISABLE	QPSK
89	1728	16/15	1/2	IBS	IBS	DISABLE	DISABLE	QPSK
90	1728	16/15	3/4	IBS	IBS	DISABLE	DISABLE	QPSK
92	1792	16/15	1/2	IBS	IBS	DISABLE	DISABLE	QPSK

99	1792	16/15	3/4	IBS	IBS	DISABLE	DISABLE	QPSK
101	2048	16/15	3/4	IBS	IBS	DISABLE	DISABLE	QPSK
102	1856	16/15	1/2	IBS	IBS	DISABLE	DISABLE	QPSK
105	1856	16/15	3/4	IBS	IBS	DISABLE	DISABLE	QPSK
106	2048	1*	3/4	IBS	IBS	DISABLE	DISABLE	QPSK
120	1544	3072/2095	3/4	IBS	IBS	DISABLE	DISABLE	QPSK
135	1984	16/15	1/2	IBS	IBS	DISABLE	DISABLE	QPSK
139	1984	16/15	3/4	IBS	IBS	DISABLE	DISABLE	QPSK
45	3088	1	1/2	CNT	V.35 (IESS)	DISABLE	DISABLE	QPSK
141	3088	1	3/4	CNT	V.35 (IESS)	DISABLE	DISABLE	QPSK
176	4000	1	1/2	CNT	V.35 (IESS)	DISABLE	DISABLE	QPSK
116	4000	1	3/4	CNT	V.35 (IESS)	DISABLE	DISABLE	QPSK
60	1344	1/15	3/4	IBS	IBS	DISABLE	DISABLE	QPSK
200	128	NONE	1/2	CNT	V.35(IESS)	DISABLE	DISABLE	QPSK

4.5 Sample DMD15/DMD15L Applications

The following section provides brief application notes for operating the DMD15/DMD15L and explains by example how to configure the DMD15/DMD15L for some of the most popular configurations.

The following information illustrates the allowable combinations for Mode and Data Rate for the DMD15/DMD15L.

Allowable Combinations: Mode/Rate/Framing.

IDR:

8.448 Mbps - 3/4, 7/8 Rate FEC
 6.312 Mbps - 1/2, 3/4, 7/8 Rate FEC
 2.048 Mbps - 1/2, 3/4, 7/8 Rate FEC
 1.544 Mbps or Below - 1/2, 3/4, 7/8 Rate FEC

IBS:

2.048 Mbps or below - 1/2, 3/4, 7/8 Rate

Closed Network:

8.448 -96 Kb Framing or No Framing, 3/4, 7/8 Rate FEC
 6.312 -96 Kb Framing or No Framing, 1/2, 3/4, 7/8 Rate FEC
 2.048 -96 Kb Framing or 1/15 Framing or No Framing, 1/2, 3/4, 7/8 Rate FEC
 1.544 -96 Kb Framing or 1/15 Framing or No Framing, 1/2, 3/4, 7/8 Rate FEC
 Any Rate 2.048 & lower - 1/15 Framing or No Framing, 1/2, 3/4, 7/8 Rate FEC

4.5.1 Operational Case Examples

Note: For best results always begin setup by setting the data rate to 512 Kbps. This data rate is applicable for all modes and as such provides a convenient launch point for setting up the modem. Any mode of operation can be entered from this starting point.

Case 1: IDR 8.448 Mbps, 3/4 Rate Viterbi

Starting with the Data Rate = 512 Kbps

Modulator:**Method 1 -**

Set mode to IDR
 Under Mod Data menu:
 Set code rate to 3/4 VIT
 Set data rate for 8448000
 Under Interface Menu:
 Set Interface type
 Set Tx clock selection
 Under Mod IF menu:
 Set desired Tx frequency and power level
 Turn IF ON

Method 2 -

Set Mod strap code to: 128
 Under Interface Menu:
 Set Interface type
 Set Tx clock selection
 Under Mod IF menu:
 Set desired Tx frequency and power level
 Turn IF on

Demodulator:**Method 1 -**

Set mode to IDR
 Under Demod IF menu: Set desired Rx frequency
 Under Demod data menu:
 Set code rate to 3/4 VIT
 Set data rate for 8448000
 Under Interface menu:
 Set Interface type
 Set Buff clock selection
 Set Buffer Size

Method 2 -

Set Demod strap code to 128
 Under Demod IF menu, set desired Rx frequency
 Under Interface Menu:
 Set Interface type
 Set Buff clock selection
 Set Buffer Size

Case 2: IBS 1.544 Mbps, 3/4 Rate Viterbi

Starting with the Data Rate – 512 Kbps

Modulator:**Method 1 -**

Set Framing to 1/15
 Set mode to IBS
 Under Mod Data menu:
 Set code rate to 3/4 VIT
 Set data rate for 1544000
 Under Interface Menu:
 Set Interface type
 Set Tx clock selection
 Under Mod IF menu: Set desired Tx frequency and power level
 Turn IF ON

Method 2 -

Set Mod strap code to: 120
 Under Interface Menu:
 Set Interface type
 Set Tx clock selection
 Under Mod IF menu: Set desired Tx frequency and power level
 Turn IF on

Demodulator:**Method 1 -**

Set Framing to 1/15:
 Set mode to IBS:
 Under Demod IF menu: Set desired Rx frequency
 Under Demod data menu:
 Set code rate to 3/4 VIT
 Set data rate for 1544000
 Under Interface menu:
 Set Interface type
 Set Buff clock selection
 Set Buffer Size

Method 2 -

Set Demod strap code to: 120
 Under Demod IF menu: Set desired Rx frequency
 Under Interface Menu:
 Set Interface type
 Set Buff clock selection
 Set Buffer Size

Case 3: Closed Network, 3/4 Rate Viterbi, IBS Overhead

Starting with the Data Rate = 512 Kbps

Modulator:

Method 1 -

Set mode to IDR:
 Under Mod Data menu:
 Set code rate to 3/4 VIT
 Set Framing for 1/15
 Under Interface Menu:
 Set Interface type
 Set Tx clock selection
 Under Mod IF menu: Set desired Tx frequency and power level
 Turn IF ON

Method 2 -

Set Mod strap code to: 101
 Under Interface Menu:
 Set Interface type
 Set Tx clock selection
 Under Mod IF menu: Set desired Tx frequency and power level
 Turn IF on

Demodulator:

Method 1 -

Set mode to: Closed Net
 Under Demod IF menu: Set desired Rx frequency
 Under Demod data menu:
 Set code rate to 3/4 VIT
 Set Framing for 1/15
 Under Interface menu:
 Set Interface type
 Set Buff clock selection
 Set Buffer Size

Method 2 -

Set Demod strap code to: 101
 Under Demod IF menu: Set desired Rx frequency
 Under Interface Menu:
 Set Interface type
 Set Buff clock selection
 Set Buffer Size

Case 4: Loop Timing Example

Method 1 -

Set mode to IBS

Under Interface menu:
 Under Tx Setup menu:
 Set INTF to RS-422
 Set SCT Source to SCR
 Set Tx Clock to SCTE

Method 2 -

Set mode to Closed Net
 Under Interface menu:
 Under Tx Setup menu:
 Set INTF to RS-422
 Set SCT Source to SCR
 Set Tx Clock to SCTE

4.6 Configuring the DMD15/DMD15L for Drop and Insert

Several dependencies exist when configuring the modem for Drop and Insert (D&I). The following paragraphs explain these dependencies and provide the user with the information required to ensure smooth transition into D&I and to minimize the potential impact of these dependencies.

4.6.1 Data Rate

Data Rate affects the Drop and Insert function in the following ways:

It determines the number of Satellite Channels that will be displayed in the Edit Maps.

It contributes to the Operational Mode selection process. Trying to change the Operational Mode to D&I when a data rate is not set to a valid D&I rate will result in the error message 'INVALID DATA RATE,' and the mode change will not be allowed.

It contributes to the Terrestrial Framing Mode selection process. Trying to select a T1-type Drop Mode such as T1-ESF with the mod data rate set to 1920000 bps (a valid E1 D&I rate but not a valid T1 rate) will result in the error message 'INVALID DROP MODE' and the selection will not be allowed. Trying to select a T1 type Insert Mode such as T1-D4 with the demod data rate set to 1920000 bps will result in the error message INVALID INSERT MODE and the selection will not be allowed.

Once D&I Mode has been selected, trying to change the data rate to something other than another valid D&I data rate will result in the error message 'RATE OUT OF BOUNDS' and the change will not be allowed.

Once D&I Mode has been selected with a T1 Terrestrial Framing Mode, attempting to change the data rate to 1920000 will result in the error message 'RATE OUT OF BOUNDS' and the change will not be allowed.

Therefore, the data rate should be entered as the first step in configuring the modem for D&I. The Mod Data Rate should be set according to the number of timeslots to be dropped and the Demod Data Rate should be set according to the number of timeslots to be inserted. The following table gives the allowable D&I data rates based on the number of slots (n) to be dropped or inserted.

n = 1, data rate = 64000
 n = 2, data rate = 128000
 n = 3, data rate = 192000
 n = 4, data rate = 256000
 n = 5, data rate = 320000
 n = 6, data rate = 384000
 n = 8, data rate = 512000
 n = 10, data rate = 640000
 n = 12, data rate = 768000

n = 15, data rate = 960000
n = 16, data rate = 1024000
n = 20, data rate = 1280000
n = 24, data rate = 1536000
n = 30, data rate = 1920000 (valid with E1 Interface only)

4.6.2 Operational Mode

The Operational Mode of the Modem often determines which additional menus and displays are available for use by the operator. The D&I Mode-specific menus will not be displayed unless the Operational Mode of the modem is set to D&I. Therefore, the second step in configuring the modem should be to set the Operational Mode to D&I. At this point, the D&I specific menus in the Interface section will become available and will remain available until the Operational Mode of the modem is changed to something other than D&I. When the Operational Mode is changed to something other than D&I, the D&I specific menus will automatically disappear.

4.6.3 Terrestrial Framing - Drop Mode/Insert Mode

The Drop Mode Selection and the Insert Mode Selection identify the Terrestrial Data-Framing Format. As previously mentioned, their selection is influenced by the Modulator and Demodulator Data Rates, and trying to select a T1 Type Framing Format with a data rate of 1920000 bps will result in an error message. In turn, the selection of the terrestrial framing formats influences the satellite channel to terrestrial timeslot mappings in the following manner:

The selection of T1-D4, T1-ESF, or SLC-96 type terrestrial framing format limits the terrestrial timeslots to values from 1-24.

The selection of PCM-30 or PCM-30C type terrestrial framing limits the terrestrial timeslots to values from 1-15, 17-31. In these modes, terrestrial timeslot 16 is reserved for ABCD signaling and may not be dropped or inserted.

The selection of PCM-31 or PCM-31C type terrestrial framing limits the terrestrial timeslots to values from 1-31. Therefore, the terrestrial framing format should be identified via the Drop Mode and Insert Mode entries prior to editing the Drop or Insert satellite channel to terrestrial timeslot maps.

4.6.3.1 Insert Terrestrial Frame Source

The Insert Terrestrial Frame Source selection tells the Modem from where the Insert Terrestrial Frame is coming.

External: Indicates that the terrestrial frame is to be input via the Insert Data In Port.
Internal: Indicates that the modem needs to generate the terrestrial frame and that all non-inserted timeslots need to be filled with the appropriate idle code based upon the terrestrial framing (T1 or E1).

The selection of the Insert Terrestrial Frame Source also influences the Buffer Clock selection in the following manner:

When the Insert Terrestrial Frame Source selection is set to External, the received satellite data will be clocked out of the Doppler Buffer based upon the clock recovered from the insert data input. Therefore, the Buffer Clock selection will automatically be set to External and cannot be

modified. Attempts to select a different buffer clock will result in the error message INVALID BUFFER CLOCK and the selection will not be allowed.

When the Insert Terrestrial Frame Source selection is set to Internal, the operator needs to specify how data should be clocked out of the Doppler Buffer. In this case, the operator will be able to select SCTE, SCT, RX SAT, or EXT EXC as the source for the Buffer Clock. Therefore, the Insert Terrestrial Frame Source selection should be made prior to attempting to change the Buffer Clock. In most instances, the Insert Terrestrial Frame Source selection will be set to External and the Buffer Clock will automatically be set to External.

4.6.4 D&I Sample Configurations and D&I Clock Setup Options

The following are several examples of how to configure the modem for D&I. Also, refer to Figures 3-14 through 3-17 for the D&I Clocking Setup Options Available.

Example 1: Drop 512 Kbps from a T1 trunk, 3/4 rate Viterbi
 Insert 512 Kbps into a T1 trunk, 3/4 rate Viterbi
 Drop 512 Kbps from a T1 trunk, 3/4 rate Viterbi

Under Modulator:

 Under Mod Data:

 Set Data Rate = 512000

 Set Conv Enc = VIT 3/4

Under Modulator:

 Set Mode = Drop & Insert

Under Interface:

Under TX Setup:

Set Tx Type according to your hardware configuration (example:
G703BT1B8ZS)

Set Tx Clock = SCTE

Under Tx D&I:

Set Drop Mode = T1-D4

Use SATCh TS edit capability to define desired mapping of
Satellite Channels to drop Terrestrial Slots

Use Map Copy to copy Tx Edit to Tx Active

Under Modulator:

Under Mod IF:

Set Frequency to desired value

Turn IF Output Power On

Under Demodulator:

Under Demod Data:

Set Data Rate = 512000

Set Conv Enc = VIT 3/4

Under Demodulator:

Set Mode = Drop & Insert

Under Interface:

Under RX Setup:

Set Rx Type according to your hardware configuration

Set Buff Size to desired depth

Under Rx D&I:

Set Insert Mode = T1-D4

Set T1 E1 Frm Src = External

Use SATCh TS edit capability to define proper mapping of
Satellite Channels to insert Terrestrial Slots

Use Map Copy to copy Rx Edit to Rx Active

Under Demodulator:

Under Demod IF:

Set Frequency to desired value

Example 2:

Multidestinational Remote Site Programming

Drop 512 Kbps from a T1 trunk, 3/4 rate Viterbi.

Extract 512 Kbps from a 1536 Kbps carrier and insert into a
T1 trunk, 3/4 rate Viterbi.

Drop 512 Kbps from a T1 trunk, 3/4 Rate Viterbi

Configuration setup is exactly as previously shown in Example 1.

Extract 512 Kbps from a 1536 Kbps carrier and insert into a T1 trunk, 3/4 Rate
Viterbi

Under Demodulator:

Under Demod Data:

Set Data Rate = 1536000

Set Conv Enc = VIT 3/4

Under Demodulator:

Set Mode = Drop & Insert

Under Interface:

Under RX Setup:

Set Rx Type according to your hardware configuration

Set Buff Size to desired depth

Under Rx D&I:

Set Insert Mode = T1-D4

Set T1 E1 Frm Src = External

Use SATCh TS edit capability to define proper mapping of Satellite Channels to insert Terrestrial Slots

For Satellite Channels that are not to be inserted, enter "NI" (No Insert) for the Terrestrial Slot

Use Map Copy to copy Rx Edit to Rx Active

Under Demodulator:

Under Demod IF:

Set Frequency to desired value.

Figures 4-3 through 4-6 illustrate D&I Clock Setup Options

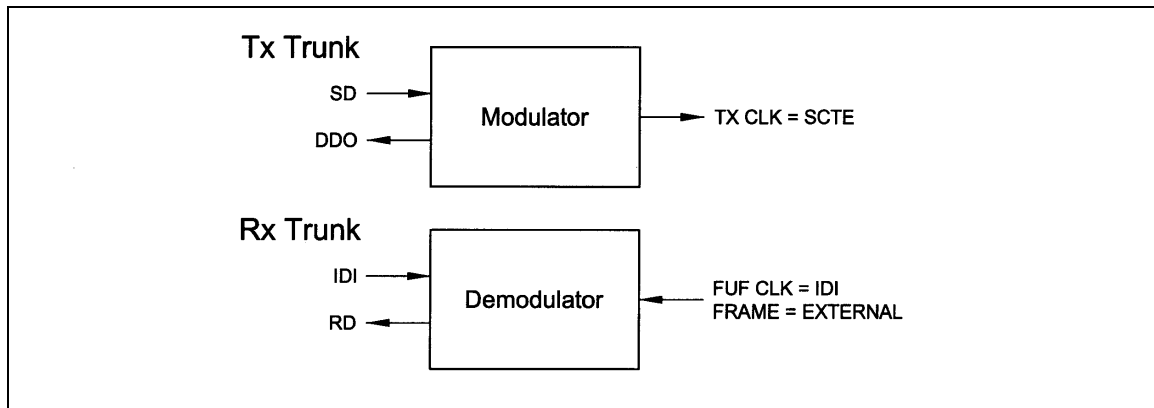

Figure 4-3. Transmit Trunk and Receive Trunk

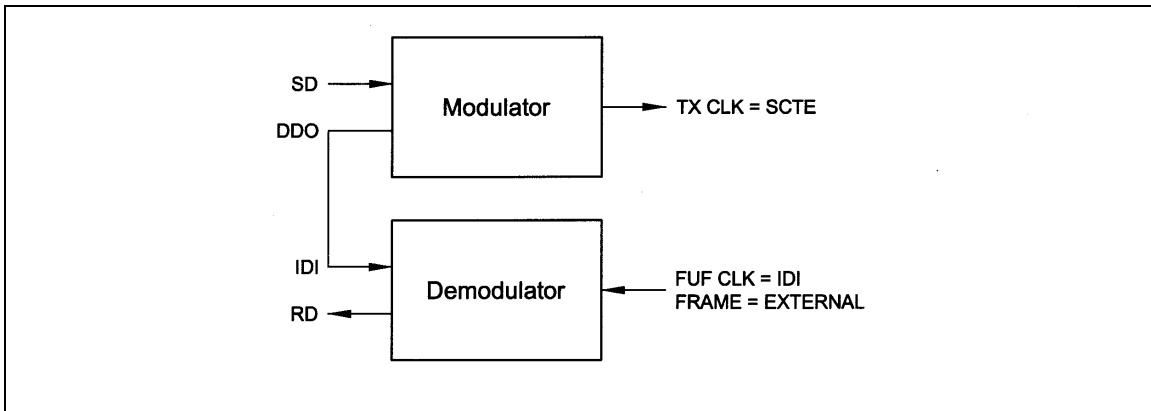

Figure 4-4. Single Trunk

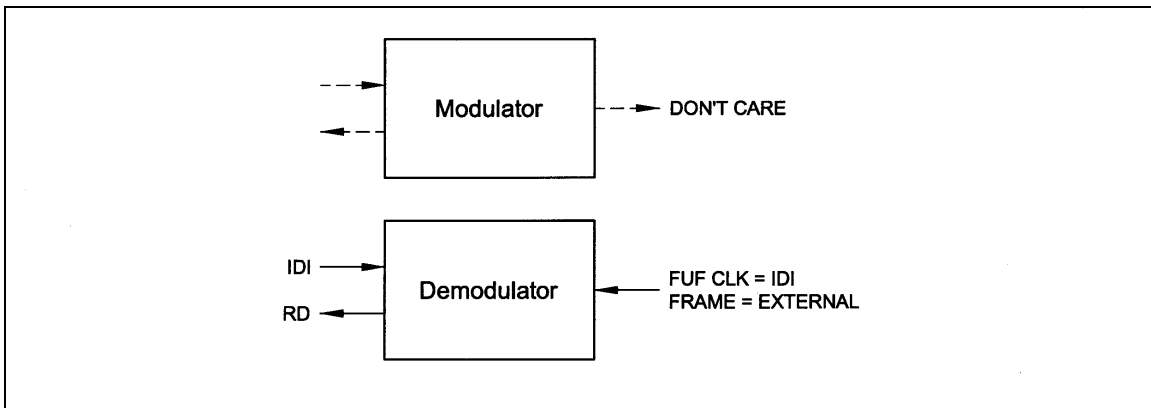

Figure 4-5. Rx Only With Trunk

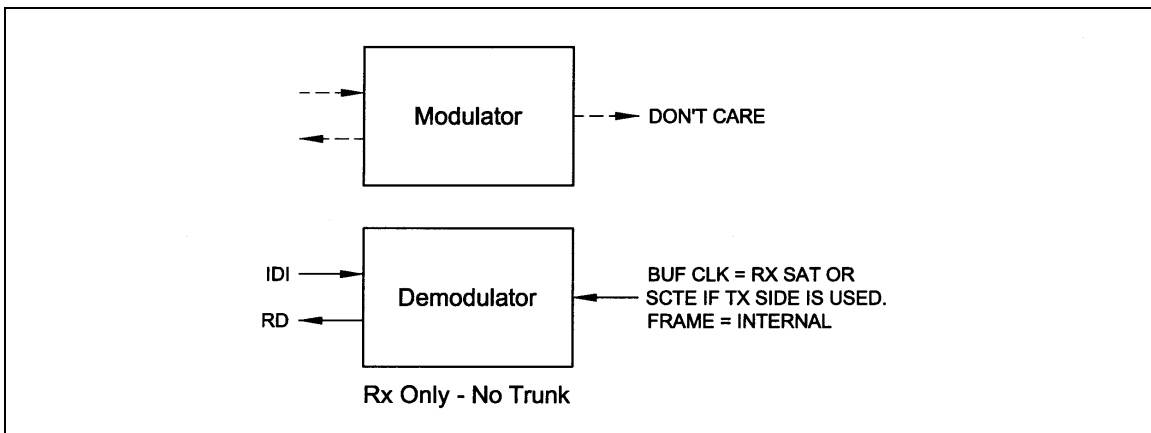

Figure 4-6. Rx Only No Trunk

4.7 D&I Maps and Map Editing

The Drop and Insert multiplexer is programmed by loading it with a transmit and receive map. Maps always contain 30 entries, although, only the first “n” entries are relevant (see Table 4-5).

The DMD15/DMD15L includes provisions to copy, change, and store the D&I transmit and receive maps directly from the Front Panel or via the remote M&C link. These maps are tables that are used to define and configure the D&I functions. Each map contains up to 30 entries, which are enough to define the channel assignments for a T1 (24 channel) or E1 (30 channel) frame structure. Maps that are created are stored in non-volatile battery backed-up memory within the modem and remain unchanged after a power-down.

Table 4-5. D&I Multiplexer Map Locations Used	
Data Rate (Kbps)	Map Locations Used (n = 1,2,4,8,16,24,30)
64	1
128	1-2
256	1-4
384	1-6
512	1-8
768	1-12
1024	1-16
1536	1-24
1920	1-30

It is important to understand that each map contains up to 30 usable entries. In many cases a smaller number of entries will be relevant, except when the data rate is 1920 Kbps, in which case 30 entries will be used by the multiplexer. To determine the number of relevant entries, divide the data rate by 64 Kbps.

For example:

At 384 Kbps, $384/64 = 6$ entries.

So in this case only the first six entries of the map would be relevant.

The Modem is equipped with eight permanently stored default maps, which are designated ROM 1 through ROM 8. The user may also define, modify, and save an additional eight maps which are designated USER 1 through USER 8. Note that the ROM maps are read-only and may not be modified (refer to Table 4-6).

Table 4-6. D&I ROM Maps

ROM Map	T1/E1 Time Slot																															
	#	1	2	3	4	5	6	7	8	9	10	11	12	13	14	15	16	17	18	19	20	21	22	23	24	25	26	27	28	29	30	31
1	1	1	1	1	1	1	1	1	1	1	1	1	1	1	1	1	1	1	1	1	1	1	1	1	1	1	1	1	1	1	1	1
2	1	2	1	2	1	2	1	2	1	2	1	2	1	2	1	2	1	2	1	2	1	2	1	2	1	2	1	2	1	2	1	2
3	1	2	3	4	1	2	3	4	1	2	3	4	1	2	3	4	1	2	3	4	1	2	3	4	1	2	3	4	1	2	3	
4	1	2	3	4	5	6	1	2	3	4	5	6	1	2	3	4	5	6	1	2	3	4	5	6	1	2	3	4	5	6		
5	1	2	3	4	5	6	7	8	1	2	3	4	5	6	7	8	1	2	3	4	5	6	7	8	1	2	3	4	5	6		
6	1	2	3	4	5	6	7	8	9	10	11	12	1	2	3	4	5	6	7	8	9	10	11	12	1	2	3	4	5	6		
7	1	2	3	4	5	6	7	8	9	10	11	12	13	14	15	16	17	18	19	20	21	22	23	24	25	26	27	28	29	30		
8	1	2	3	4	5	6	7	8	9	10	11	12	13	14	15	17	18	19	20	21	22	23	24	25	26	27	28	29	30	31		

Since the D&I Functions are separate and distinct, two separate maps must be configured at the start of the D&I Multiplexer Operation. These are the Tx (transmit) Active Map for Drop Mapping and the Rx (receive) Active Map for Insert Mapping. The number of entries in each map is determined by the data rates selected. Each map entry consists of an IBS Time Slot assignment and the Terrestrial (T1 or E1) Channel Number it is assigned to. Drop Mapping and Insert Mapping are completely separate and independent.

The map that is actually used for the Drop Function is the Tx Active Map; the map that is actually used for the Insert function is the Rx Active Map. Two additional maps exist: the Tx Edit Map and the Rx Edit Map. The Edit Maps are the buffer areas that are used when creating or modifying a map through the modem’s LCD; when editing is complete, the appropriate map should be copied to the Active Map.

Any map may be copied to any other map with the exception of the ROM maps. These maps may only be the source of the data used to create a User, Edit, or Active Map.

Maps can be created in the map editor and stored as “User Maps”. New “Active Maps” can be downloaded during Modem Operation but this will result in a temporary disruption of service on the terrestrial line or the Satellite transmission.

The following paragraphs give examples of typical configurations that could use the ROM Maps as templates. The ROM Map used would have to be first copied to the appropriate Active Transmit (Drop) and/or Active Receive (Insert) Map(s) before it could be used. To use a modification of a ROM Map, the ROM Map must first be copied to the appropriate Edit Map, then modified, and then copied to the appropriate Active Map.

Note: The mapping of channels to time slots is arbitrary; it is not necessary to map CH1 to TS1, CH2 to TS2, etc. The channel to the time slot mapping may be in any order within the constraints of the number of available channels.

For example, ROM Map 1 could be used as the template for as Active Transmit (Drop) Map for a modulator configured for 64 Kbps operation. Only the first time slot of the T1 or E1 frame would be dropped into the modulator transmit path. The Drop Multiplexer would know to look only at the

first entry in the Active Transmit table and would ignore the other 29 entries. If the map contained an "8" in its first entry, the eighth channel of the T1/E1 frame would be sent to the modulator.

ROM Map 2 could be used as the template for an Active Receive (Insert) Map for a demodulator configured for 128 Kbps operation. The demodulated data in the receive path would be inserted into the first two time slots of the T1 or E1 frame. The Insert Multiplexer would know to look only at the first two entries in the Active Receive table and would ignore the other 28 entries. If the first two entries were modified to contain a 27 and 28, the data would be inserted into the 27th and 28th time slots of the E1 frame.

ROM Map 3 could be used as the template for an Active Transmit (Drop) Map with a modulator and/or demodulator configured for 256 Kbps operation. The T1 or E1 Data in the transmit path or the demodulated data in the receive path would be dropped from and/or inserted into the first four time slots of the T1 or E1 frame. The Multiplexer would know to look only at the first four entries in the Active map(s) and would ignore the other 26 entries.

ROM Map 4 could be used as the template for an Active Transmit (Drop) or Active Receive (Insert) Map with a modulator and/or demodulator configured for 384 Kbps operation. The T1 or E1 Data in the transmit path or the demodulated data in the receive path would be dropped from and/or inserted into the first six time slots of the T1 or E1 frame. The Insert Multiplexer would know to look only at the first six entries in the Active map(s) and would ignore the other 24 entries. To Drop the last six channels of a T1 frame into a modulator transmit path, the first six entries of the Active Transmit map should contain 19, 20, 21, 22, 23, and 24.

ROM Map 5 could be used as the template for an Active Transmit (Drop) and/or Active Receive (Insert) Map with a modulator and/or demodulator configured for 512 Kbps operation. The T1 or E1 Data in the transmit path or the demodulated data in the receive path would be dropped from and or inserted into the first eight time slots of the T1 or E1 frame. The Multiplexer would know to look only at the first eight entries in the Active map(s) and would ignore the other 22 entries. To insert data received from a demodulator into channels 17 through 24 of an E1 frame, the first eight entries of the Active Receive map should contain 17, 18, 19, 20, 21, 22, 23, and 24.

ROM Map 6 could be used as the template for an Active Transmit (Drop) and/or Active Receive (Insert) Map with a modulator and/or demodulator configured for 768 Kbps operation. The T1 or E1 Data in the transmit path or the demodulated data in the receive path would be dropped from and or inserted into the first 12 time slots of the T1 or E1 frame. The Multiplexer would know to look only at the first 12 entries in the Active map(s) and would ignore the other 18 entries. To insert data received from a demodulator into channels 3 through 14 of an E1 frame, the first 12 entries of the Active Receive map should contain 3, 4, 5, 6, 7, 8, 9, 10, 11, 12, 13, and 14.

ROM Map 7 could be used as the template for an Active Transmit (Drop) and/or Active Receive (Insert) Map with a modulator and/or demodulator configured for 1920 Kbps operation. This would be used with E1 frames where time slot 16 is not used for the multiframe alignment signal and therefore channels 1 through 30 are mapped directly with time slots 1 through 30.

ROM Map 7 could also be used as the template for an Active Transmit (Drop) and/or Active Receive (Insert) Map with a modulator and/or demodulator configured for 1024 Kbps operation. This would be used with T1 or E1 frames where channels 1 through 16 are mapped into time slots 1 through 16 (in any order). Map slots 17 through 30 would be ignored.

ROM Map 7 could also be used as the template for an Active Transmit (Drop) and/or Active Receive (Insert) Map with a modulator and/or demodulator configured for 1536 Kbps operation. This would be used with T1 frames where channels 1 through 24 are mapped into time slots 1 through 24 (in any order). Map slots 25 through 30 would be ignored.

ROM Map 8 could also be used as the template for an Active Transmit (Drop) and/or Active Receive (Insert) Map with a modulator and/or demodulator configured for 1920 Kbps operation. However, this mapping would be relevant with E1 frames where time slot 16 is used for the

multiframe alignment signal and therefore channels 1 through 30 are mapped to time slots 1 through 16 and 17 through 31.

4.8 Terminal Mode Control

The DMD15/DMD15L Terminal Mode Control allows the use of an external terminal or computer to monitor and control the modem from a full screen interactive presentation operated by the modem itself. No external software is required other than VT100 Terminal Emulation Software (e.g. "Procomm" for a computer when used as a terminal. The Control Port is normally used as an RS-232 Connection to the terminal device. The RS-232 operating parameters can be set using the modem Front Panel and stored in EEPROM for future use.

4.8.1 Modem Terminal Mode Control

The modem can be interactively monitored and controlled in the Terminal Mode, with a full screen presentation of current settings and status. Programming is accomplished by selecting the item to be modified and pressing the terminal key of the option number. For example, to change the transmit data rate, enter '33' at the terminal. The modem will respond by presenting the options available and requesting input. Two types of input may be requested. If the input is multiple choice, the desired choice is selected by pressing the 'Space' key. When the desired option is displayed, press the 'Enter' key to select that option. The other possible input type requires a numerical input (such as entering a frequency or data rate. This type of input is followed by pressing the 'Enter' or carriage return key. An input can be aborted at any time by pressing the 'ESC' key. Invalid input keys cause an error message to be displayed on the terminal.

The Terminal Control Mode supports serial baud rates of 150, 300, 1200, 2400, 4800, 9600, 19200, and 38400. The connection must be set for 8 data bits, 1 stop bit and no parity (8,N,1). Three terminal emulations are supported: VT100, WYSE 50, and ADDS-VP.

"\$" is used for setting the screen when the terminal is used is used for the first time or the non-volatile memory gets reset.

4.8.2 Modem Setup for Terminal Mode

Terminal Mode Communications and Protocol is set from the Front Panel Control by setting the "Control Mode" Parameter to "Terminal", and then setting the "Modem Port", "Term Baud" and "Emulation" Parameters as desired. Then a terminal is connected to Connector J5 on the Back Panel. All operating software for the Terminal Mode is contained within the DMD15/DMD15L Modem Internal Control Software.

A "break" signal on the communications line, pressing "ESC" on the terminal or Power On of the modem will initiate full screen terminal mode printing and redraw the full screen. The Terminal Mode displays the present status of all user parameters controlled and read by the processor, and offers a menu allowing change to any controlled parameter.

The Terminal Mode uses eight "Screens," each of which have the basic contents of the three modem monitor and control areas as set in the Front Panel matrix columns. This screen is used for setting the parameters of the Modulator, Demodulator, Event, Alarm, Latched Alarm, Drop Controls, Insert Controls, and Interface Areas.

4.9 Modem Remote Communications

4.9.1 Host Computer Remote Communications

NOTE: *This specification is applicable to the DMD15, DMD10 and DMD10L Modems. Any reference to the DMD15 in this document can be applicable to any one of these three modems.*

Control and status messages are conveyed between the DMD15 and the subsidiary modems and the host computer using packetized message blocks in accordance with a proprietary communications specification. This communication is handled by the Radyne Link Level Protocol (RLLP), which serves as a protocol 'wrapper' for the RM&C data. Complete information on monitor and control software is contained in the following sections.

4.9.1.1 Protocol Structure

The Communications Specification (COMMSPEC) defines the interaction of computer resident Monitor and Control Software used in satellite earth station equipment such as modems, redundancy switches, multiplexers, and other ancillary support gear. Communication is bi-directional, and is normally established on one or more full-duplex 9600-baud multi-drop control buses that conform to EIA Standard RS-485.

Each piece of earth station equipment on a control bus has a unique physical address, which is assigned during station setup/configuration or prior to shipment. Valid decimal addresses on one control bus range from 032 through 255 for a total of up to 224 devices per bus. Address 255 of each control bus is usually reserved for the M&C computer.

4.9.1.2 Protocol Wrapper

The Radyne COMMSPEC is byte-oriented, with the Least Significant Bit (LSB) issued first. Each data byte is conveyed as mark/space information with two marks comprising the stop data. When the last byte of data is transmitted, a hold comprises one steady mark (the last stop bit). To begin or resume data transfer, a space (00h) substitutes this mark. This handling scheme is controlled by the hardware and is transparent to the user. A pictorial representation of the data and its surrounding overhead may be shown as follows:

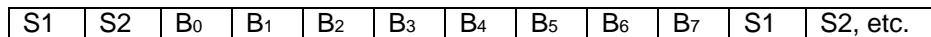

The Stop Bits, S1 and S2, are each a mark. Data flow remains in a hold mode until S2 is replaced by a space. If S2 is followed by a space, it is considered a start bit for the data byte and not part of the actual data (B₀ - B₇).

The COMMSPEC developed for use with the Radyne Link Level Protocol (RLLP) organizes the actual monitor and control data within a shell, or 'protocol wrapper', that surrounds the data. The format and structure of the COMMSPEC message exchanges are described herein. Decimal numbers have no suffix; hexadecimal numbers end with a lower case 'h' suffix and binary values have a lower case 'b' suffix. Thus, 22 = 16h = 000010110b. The principal elements of a data frame, in order of occurrence, are summarized as follows:

<SYNC>:

The message format header character, or ASCII sync character, that defines the beginning of a message. The <SYNC> character value is always 16h.

<BYTE COUNT>:

The Byte Count is the number of bytes in the <DATA> field, ranging from 0 through 255 for the DMD5000 protocol (1 Byte), or ranging from 0 through 509 for the DMD15 protocol (2 Bytes).

- <SOURCE ID>:** The Source Identifier defines the multi-drop address origin.
- Note:** *All nodes on a given control bus have a unique address that must be defined.*
- <DESTINATION ID>:** The Destination Identifier serves as a pointer to the multi-drop destination device that indicates where the message is to be sent.
- <FRAME SEQUENCE NUMBER>:** The Frame Sequence Number (FSN) is a tag with a value from 0 through 255 that is sent with each message. It assures sequential information framing and correct equipment acknowledgment and data transfers.
- <OPCODE>:** The Operation Code field contains a number that identifies the message type associated with the data that follows it. Equipment under MCS control recognizes this byte via firmware identification and subsequently steers the DATA accordingly to perform a specific function or series of functions. Acknowledgment and error codes are returned in this field. 1 Byte for the DMD5000 protocol, and 2 Bytes for the DMD15 protocol.
- <DATA >:** The Data field contains the binary, bi-directional data bytes associated with the <OPCODE>. The number of data bytes in this field is indicated by the <BYTE COUNT> value.
- <CHECKSUM>:** The checksum is the modulo 256 sum of all preceding message bytes, excluding the <SYNC> character. The checksum determines the presence or absence of errors within the message. In a message block with the following parameters, the checksum is computed as shown in Table 4-7.

BYTE FIELD	DATA CONTENT	RUNNING CHECKSUM
<BYTE COUNT> (Byte 1)	00h = 00000000b	00000000b
<BYTE COUNT> (Byte 2)	02h = 00000010b	00000010b
<SOURCEID>	F0h = 11110000b	11110010b
<DESTINATION ID>	2Ah = 00101010b	00011100b
<FSN>	09h = 00001001b	00100101b
<OPCODE> (Byte 1)	00h = 00000000b	00100101b
<OPCODE> (Byte 2)	03h = 00000011b	00101000b
<DATA> (Byte 1)	DFh = 11011111b	00000111b
<DATA> (Byte 2)	FEh = 11111110b	00000101b

Thus, the checksum is 00000101b; which is 05h or 5 decimal. Alternative methods of calculating the checksum for the same message frame are:

$$00h + 02h + F0h + 2Ah + 09h + 00h + 03h + DFh + FEh = 305h.$$

Since the only concern is the modulo 256 (modulo 1 00h) equivalent (values that can be represented by a single 8-bit byte), the checksum is 05h.

For a decimal checksum calculation, the equivalent values for each information field are:

$$0 + 2 + 240 + 42 + 9 + 0 + 3 + 223 + 254 = 773;$$

$$773/256 = 3 \text{ with a remainder of } 5.$$

This remainder is the checksum for the frame.

$$5 \text{ (decimal)} = 05h = 0101b = \text{<CHECKSUM>}$$

4.9.1.3 Frame Description and Bus Handshaking

In a Monitor and Control environment, every message frame on a control bus port executes as a packet in a loop beginning with a wait-for-SYNC-character mode. The remaining message format header information is then loaded, either by the M&C computer or by a subordinate piece of equipment (such as the DMD15) requesting access to the bus. Data is processed in accordance with the OPCODE, and the checksum for the frame is calculated. If the anticipated checksum does not match, then a checksum error response is returned to the message frame originator. The entire message frame is discarded and the wait-for-SYNC mode goes back into effect. If the OPCODE resides within a command message, it defines the class of action that denotes an instruction that is specific to the device type, and is a prefix to the DATA field if data is required. If the OPCODE resides within a query message packet, then it defines the query code, and can serve as a prefix to query code DATA.

The Frame Sequence Number (FSN) is included in every message packet, and increments sequentially. When the M & C computer or bus-linked equipment initiates a message, it assigns the FSN as a tag for error control and handshaking. A different FSN is produced for each new message from the FSN originator to a specific device on the control bus. If a command packet is sent and not received at its intended destination, then an appropriate response message is not received by the packet originator. The original command packet is then re-transmitted with the same FSN. If the repeated message is received correctly at this point, it is considered a new message and is executed and acknowledged as such.

If the command packet is received at its intended destination but the response message (acknowledgment) is lost, then the message originator (usually the M&C computer) re-transmits the original command packet with the same FSN. The destination device detects the same FSN and recognizes that the message is a duplicate, so the associated commands within the packet are not executed a second time. However, the response packet is again sent back to the source as an acknowledgment in order to preclude undesired multiple executions of the same command.

To reiterate, valid equipment responses to a message require the FSN tag in the command packet. This serves as part of the handshake/acknowledge routine. If a valid response message is absent, then the command is re-transmitted with the same FSN. For a repeat of the same command involving iterative processes (such as increasing or decreasing the transmit power level of a DMD15 modulator), the FSN is incremented after each message packet. When the FSN value reaches 255, it overflows and begins again at zero. The FSN tag is a powerful tool that assures sequential information framing, and is especially useful where commands require more than one message packet.

The full handshake/acknowledgment involves a reversal of source and destination ID codes in the next message frame, followed by a response code in the <OPCODE> field of the message packet from the equipment under control.

If a command packet is sent and not received at its intended destination, a timeout condition can occur because a response message is not received by the packet originator. On receiving devices slaved to an M & C computer, the timeout delay parameters may be programmed into the equipment in accordance with site requirements by Radyne Corp. prior to shipment, or altered by qualified personnel. The FSN handshake routines must account for timeout delays and be able to introduce them as well.

4.9.1.4 Global Response Operational Codes

In acknowledgment (response) packets, the operational code <OPCODE> field of the message packet is set to 0 by the receiving devices when the message intended for the device is evaluated as valid. The device that receives the valid message then exchanges the <SOURCE ID> with the <DESTINATION ID>, sets the <OPCODE> to zero in order to indicate that a good message was received, and returns the packet to the originator. This "GOOD MESSAGE" Opcode is one of nine global responses. Global response opcodes are common responses, issued to the M&C computer or to another device, that can originate from and are interpreted by all Radyne equipment in the same manner. These are summarized as follows (all opcode values are expressed in decimal form):

Table 4-8. Response OPCODES	
Response OPCODE Description	OPCODE
Good Message	000d = 0000h
Bad Parameter	255d = 00FFh
Bad Opcode	254d = 00FEh
Bad Checksum	253d = 00FDh
Command Not Allowed in LOCAL Mode	252d = 00FCh
Command Not Allowed in AUTO Mode	251d = 00FBh
Bad Destination	250d = 00FAh
Unable to Process Command	249d = 00F9h
Packet Too Long	248d = 00F8h

The following response error codes are specific to the DMD15:

DMD15 Response Error Code Descriptions	OPCODE
MPARM_MODEMNUMBER_ERROR	0x0400
MPARM_FREQUENCY_ERROR	0x0401
MPARM_STRAP_ERROR	0x0402
MPARM_FILTERMASK_ERROR	0x0403
MPARM_DATARATE_ERROR	0x0404
MPARM_EXTEXCCLOCK_ERROR	0x0405
MPARM_EXTREFERENCE_ERROR	0x0406

MPARM_EXTREFSOURCE_ERROR	0x0407
MPARM_MODULATIONTYPE_ERROR	0x0408
MPARM_CONVENCODER_ERROR	0x0409
MPARM_REEDSOLOMON_ERROR	0x040A
MPARM_SCRAMBLERCONTROL_ERROR	0x040B
MPARM_SCRAMBLERTYPE_ERROR	0x040C
MPARM_IBSSCRAMBLER_ERROR	0x040D
MPARM_V35SCRAMBLER_ERROR	0x040E
MPARM_DIFFERENTIALENCODER_ERROR	0x040F
MPARM_XMITPOWERLEVEL_ERROR	0x0410
MPARM_CARRIERCONTROL_ERROR	0x0411
MPARM_CARRIERSELECTION_ERROR	0x0412
MPARM_SPECTRUM_ERROR	0x0413
MPARM_OPERATINGMODE_ERROR	0x0414
MPARM_TERRLOOPBACK_ERROR	0x0415
MPARM_BASELOOPBACK_ERROR	0x0416
MPARM_CLOCKCONTROL_ERROR	0x0417
MPARM_CLOCKPOLARITY_ERROR	0x0418
MPARM_FRAMING_ERROR	0x0419
MPARM_DROPMODE_ERROR	0x041A
MPARM_SCTSOURCE_ERROR	0x041B
MPARM_DROPMAP_ERROR	0x041D
MPARM_T1D4YELLOW_ERROR	0x041E
MPARM_FORCEDALARMS_ERROR	0x041F
MPARM_ALARMMASKENABLE_ERROR	0x0420
MPARM_ALARMMASK_ERROR	0x0421
MPARM_MODE_ERROR	0x0422
MPARM_CIRCUITID_ERROR	0x0423
MPARM_ESCCHANNEL1VOLUME_ERROR	0x0424
MPARM_ESCCHANNEL2VOLUME_ERROR	0x0425
MPARM_TERRESTRIAL_LOOPBACK_ERROR	0x0426
MPARM_INTERFACE_LOOPBACK_ERROR	0x0427
MPARM_IF_LOOPBACK_ERROR	0x0428
MPARM_INTERFACETYPE_ERROR	0x0429
MPARM_INTERFACENOTPRESENT_ERROR	0x042A
MPARM_INTERFACECOMMUNICATION_ERROR	0x042B

MPARM_SYMBOLRATE_ERROR	0x042C
MPARM_NOTIMPLEMENTED_ERROR	0x042D
MPARM_TRANSFERTYPE_ERROR	0x042F
MPARM_SUMMARYFAULT_ERROR	0x0430
MPARM_DATAINVERT_ERROR	0x0431
MPARM_ESCSOURCE_ERROR	0x0432
MPARM_FMORDERWIRE_ERROR	0x0433
MPARM_FMTESTTONE_ERROR	0x0434
MPARM_AUPCLOCALENABLE_ERROR	0x0435
MPARM_AUPCREMOTEENABLE_ERROR	0x0436
MPARM_AUPCLOCALCLACTION_ERROR	0x0437
MPARM_AUPCREMOTECLACTION_ERROR	0x0438
MPARM_AUPCTRACKINGRATE_ERROR	0x0439
MPARM_AUPCREMOTEBBLOOPBACK_ERROR	0x043A
MPARM_AUPCREMOTE2047_ERROR	0x043B
MPARM_AUPCEBNO_ERROR	0x043C
MPARM_AUPCMINPOWER_ERROR	0x043D
MPARM_AUPCMAXPOWER_ERROR	0x043E
MPARM_AUPCNOMINALPOWER_ERROR	0x043F
MPARM_CONFIGURATIONSOURCE_ERROR	0x0440
MPARM_CONFIGURATIONDESTINATION_ERROR	0x0441
MPARM_CONFIGURATION_ERROR	0x0442
MPARM_CARRIERDELAY_ERROR	0x0443
MPARM_TIME_MARK_ERROR	0x0444
DPARAM_MODE_ERROR	0x0600
DPARAM_FREQUENCY_ERROR	0x0601
DPARAM_SWEEPDELAY_ERROR	0x0602
DPARAM_DATARATE_ERROR	0x0603
DPARAM_SWEEPBOUNDARY_ERROR	0x0604
DPARAM_LEVELLIMIT_ERROR	0x0605
DPARAM_STRAP_ERROR	0x0606
DPARAM_FILTERMASK_ERROR	0x0607
DPARAM_DEMODULATIONTYPE_ERROR	0x0608
DPARAM_CONVDECODER_ERROR	0x0609
DPARAM_REEDSOLOMON_ERROR	0x060A

DPARM_DIFFERENTIALDECODER_ERROR	0x060B
DPARM_DESCRAMBLERCONTROL_ERROR	0x060C
DPARM_DESCRAMBLERTYPE_ERROR	0x060D
DPARM_SPECTRUM_ERROR	0x060E
DPARM_BUFFERSIZE_ERROR	0x060F
DPARM_BUFFERCLOCK_ERROR	0x0610
DPARM_BUFFERCLOCKPOL_ERROR	0x0611
DPARM_INSERTMODE_ERROR	0x0612
DPARM_T1SIGNALING_ERROR	0x0613
DPARM_T1E1FRAMESOURCE_ERROR	0x0614
DPARM_FRAMING_ERROR	0x0615
DPARM_OPERATINGMODE_ERROR	0x0616
DPARM_MAPSUMMARY_ERROR	0x0617
DPARM_AUTOALARM_ERROR	0x0618
DPARM_BEREXPONENT_ERROR	0x0619
DPARM_CIRCUITID_ERROR	0x061A
DPARM_TERRLOOPBACK_ERROR	0x061B
DPARM_BASELOOPBACK_ERROR	0x061C
DPARM_IFLOOPBACK_ERROR	0x061D
DPARM_INTERFACETYPE_ERROR	0x061E
DPARM_INTERFACENOTPRESENT_ERROR	0x061F
DPARM_INTERFACECOMMUNICATION_ERROR	0x0620
DPARM_SYMBOLRATE_ERROR	0x0621
DPARM_NOTIMPLEMENTED_ERROR	0x0622
DPARM_DATAINVERT_ERROR	0x0623
DPARM_SUMMARYFAULT_ERROR	0x0624
DPARM_EXTERNALEXCOURCE_ERROR	0x0625
DPARM_CLEARLATCHEDALARM1_ERROR	0x0626
DPARM_CLEARLATCHEDALARM2_ERROR	0x0627
DPARM_CLEARLATCHEDALARM3_ERROR	0x0628
DPARM_ASYNCMODE_ERROR	0x062C
DPARM_ASYNCBAUDRATE_ERROR	0x062D
DPARM_ASYNCCTYPE_ERROR	0x062E
DPARM_ASYNCDATABITS_ERROR	0x062F
DPARM_TIME_MARK_ERROR	0x0630
DPARM_REACQ_SWEEP_LIMIT_ERROR	0x0631

MDPARAM_MAPNUMBER_ERROR	0x0A00
MDPARAM_TIME_ERROR	0x0A01
MDPARAM_DATE_ERROR	0x0A02
MDPARAM_TERMINALEMULATION_ERROR	0x0A05
MDPARAM_TERMINALBAUDRATE_ERROR	0x0A06
MDPARAM_EBNO_THRESHOLD_ERROR	0x0A07

4.9.1.5 Collision Avoidance

When properly implemented, the physical and logical devices and ID addressing scheme of the COMMSPEC normally precludes message packet contention on the control bus. The importance of designating unique IDs for each device during station configuration cannot be overemphasized. One pitfall, which is often overlooked, concerns multi-drop override IDs. All too often, multiple devices of the same type are assigned in a direct-linked ("single-thread") configuration accessible to the M&C computer directly.

For example, if two DMD15 Modems with different addresses (DESTINATION IDs) are linked to the same control bus at the same hierarchical level, both will attempt to respond to the M&C computer when the computer generates a multi-drop override ID of 22. If their actual setup parameters, status, or internal timing differs, they will both attempt to respond to the override simultaneously with different information or asynchronously in their respective message packets and response packets, causing a collision on the serial control bus.

To preclude control bus data contention, different IDs must always be assigned to the equipment. If two or more devices are configured for direct-linked operation, then the M&C computer and all other devices configured in the same manner must be programmed to inhibit broadcast of the corresponding multi-drop override ID.

The multi-drop override ID is always accepted by devices of the same type on a common control bus, independent of the actual DESTINATION ID. These override IDs with the exception of "BROADCAST" are responded to by all directly-linked devices of the same type causing contention on the bus. The "BROADCAST" ID, on the other hand, is accepted by all equipment but none of them returns a response packet to the remote M&C.

The following multi-drop override IDs are device-type specific, with the exception of "BROADCAST". These are summarized below with ID values expressed in decimal notation:

Directly-Addressed Equipment	Multi-Drop Override ID
Broadcast (all directly-linked devices)	00
DMD-3000/4000, 4500 or 5000 Mod Section, DMD15	01
DMD-3000/4000, 4500 or 5000 Demod Section, DMD15	02
RCU-340 1:1 Switch	03
RCS-780 1:N Switch	04
RMUX-340 Cross-Connect Multiplexer	05
CDS-780 Clock Distribution System	06
SOM-340 Second Order Multiplexer	07
DMD-4500/5000 Modulator Section	08
DMD-4500/5000 Demodulator Section	09
RCU-5000 M:N Switch	10
DMD15 Modulator	20
DMD15 Demodulator	21
DMD15 Modem	22
DVB3000/3030 Video Modulator, DM240	23
RCS20 M:N Switch	24
RCS10 M:N Switch	25
RCS11 1:1 Switch	26
Reserved for future equipment types	27-31

Note that multi-drop override IDs 01 or 02 can be used interchangeably to broadcast a message to a DMD-3000/4000 modem, or to a DMD-4500/5000, or to a DMD15 modem. Radyne Corp. recommends that the multi-drop override IDs be issued only during system configuration as a bus test tool by experienced programmers, and that they not be included in run-time software. It is also advantageous to consider the use of multiple bus systems where warranted by a moderate to large equipment complement.

Therefore, if a DMD15 Modulator is queried for its equipment type identifier, it will return a "20" and DMD15 Demodulator will return a "21". A DMD15 Modem will also return a "22".

4.9.1.6 Software Compatibility

The COMMSPEC, operating in conjunction within the RLLP shell, provides for full forward and backward software compatibility independent of the software version in use. New features are appended to the end of the DATA field without OPCODE changes. Older software simply discards the data as extraneous information without functional impairment for backward compatibility.

If new device-resident or M&C software receives a message related to an old software version, new information and processes are not damaged or affected by the omission of data.

The implementation of forward and backward software compatibility often, but not always, requires the addition of new Opcodes. Each new function requires a new Opcode assignment if forward and backward compatibility cannot be attained by other means.

When Radyne , Inc. equipment is queried for bulk information (Query Mod, Query Demod, etc.) it responds by sending back two blocks of data; a Non-Volatile Section (parameters that can be modified by the user) and a Volatile Section (status information). It also returns a count value that indicates the size of the Non-Volatile Section. This count is used by M&C developers to index into the start of the Volatile Section.

When new features are added to Radyne equipment, the control parameters are appended to the end of the Non-Volatile Section, and status of the features, if any, are added at the end of the Volatile Section. If a remote M&C queries two pieces of Radyne equipment with different revision software, they may respond with two different sized packets. The remote M&C MUST make use of the non-volatile count value to index to the start of the Volatile Section. If the remote M&C is not aware of the newly added features to the Radyne product, it should disregard the parameters at the end of the Non-Volatile Section and index to the start of the Volatile Section.

If packets are handled in this fashion, there will also be backward-compatibility between Radyne , Inc. equipment and M&C systems. Remote M&C systems need not be modified every time a feature is added unless the user needs access to that feature.

4.9.1.7 Flow Control and Task Processing

The original packet sender (the M&C Computer) relies on accurate timeout information with regard to each piece of equipment under its control. This provides for efficient bus communication without unnecessary handshake overhead timing. One critical value is designated the Inter-Frame Space (FS). The Inter-Frame Space provides a period of time in which the packet receiver and medium (control bus and M&C Computer interface) fully recover from the packet transmission/reception process and the receiver is ready to accept a new message. The programmed value of the Inter-Frame Space should be greater than the sum of the "turnaround time" and the round-trip (sender/receiver/bus) propagation time, including handshake overhead. The term "turnaround time" refers to the amount of time required for a receiver to be re-enabled and ready to receive a packet after having just received a packet. In flow control programming, the Inter-Frame Space may be determined empirically in accord with the system configuration, or calculated based on established maximum equipment task processing times.

Each piece of supported equipment on the control bus executes a Radyne Link Level Task (RLLT) in accordance with its internal hardware and fixed program structure. In a flow control example, the RLLT issues an internal "message in" system call to invoke an I/O wait condition that persists until the task receives a command from the M & C computer. The RLLT has the option of setting a timeout on the incoming message. Thus, if the equipment does not receive an information/command packet within a given time period, the associated RLLT exits the I/O wait state and takes appropriate action.

Radyne equipment is logically linked to the control bus via an Internal I/O Processing Task (IOPT) to handle frame sequencing, error checking, and handshaking. The IOPT is essentially a link between the equipment RLLT and the control bus. Each time the M&C computer sends a message packet, the IOPT receives the message and performs error checking. If errors are absent, the IOPT passes the message to the equipment's RLLT. If the IOPT detects errors, it appends error messages to the packet. Whenever an error occurs, the IOPT notes it and discards the message; but it keeps track of the incoming packet. Once the packet is complete, the IOPT conveys the appropriate message to the RLLT and invokes an I/O wait state (wait for next <SYNC> character).

If the RLLT receives the packetized message from the sender before it times out, it checks for any error messages appended by the IOPT. In the absence of errors, the RLLT processes the received command sent via the transmitted packet and issues a "message out" system call to ultimately acknowledge the received packet. This call generates the response packet conveyed to the sender. If the IOPT sensed errors in the received packet and an RLLT timeout has not occurred, the RLLT causes the equipment to issue the appropriate error message(s) in the pending equipment response frame.

To maintain frame synchronization, the IOPT keeps track of error-laden packets and packets intended for other equipment for the duration of each received packet. Once the packet is complete, the IOPT invokes an I/O wait state and searches for the next <SYNC> character.

4.9.1.8 RLLP Summary

The RLLP is a simple send-and-wait protocol that automatically re-transmits a packet whenever an error is detected, or when an acknowledgment (response) packet is absent.

During transmission, the protocol wrapper surrounds the actual data to form information packets. Each transmitted packet is subject to time out and frame sequence control parameters, after which the packet sender waits for the receiver to convey its response. Once a receiver verifies that a packet sent to it is in the correct sequence relative to the previously received packet, it computes a local checksum on all information within the packet excluding the <SYNC> character and the <CHECKSUM> fields. If this checksum matches the packet <CHECKSUM>, the receiver processes the packet and responds to the packet sender with a valid response (acknowledgment) packet. If the checksum values do not match, the receiver replies with a negative acknowledgment (NAK) in its response frame.

The response packet is therefore either an acknowledgment that the message was received correctly, or some form of a packetized NAK frame. If the sender receives a valid acknowledgment (response) packet from the receiver, the <FSN> increments and the next packet is transmitted as required by the sender. However, if a NAK response packet is returned the sender re-transmits the original information packet with the same embedded <FSN>.

If an acknowledgment (response) packet or a NAK packet is lost, corrupted, or not issued due to an error and is thereby not returned to the sender, the sender re-transmits the original information packet; but with the same <FSN>. When the intended receiver detects a duplicate packet, the packet is acknowledged with a response packet and internally discarded to preclude undesired repetitive executions. If the M&C computer sends a command packet and the corresponding response packet is lost due to a system or internal error, the computer times out and re-transmits

the same command packet with the same <FSN> to the same receiver and waits once again for an acknowledgment or a NAK packet.

To reiterate, the format of the Link Level Protocol Message Block is shown below.

SYNC	COUNT	SRC ADDR	DEST ADDR	FSN	OPCODE	DATA BYTES	CHECKSUM
------	-------	-------------	--------------	-----	--------	---------------	----------

4.9.2 Remote Port Packet Structure:

The Modem protocol is an enhancement on the DMD5000 protocol. It also uses a packet structure format. The structure is as follows:

<SYNC>:	Message format header character that defines the beginning of a message. The <SYNC> character value is always 0x16 (1 byte).
<BYTE COUNT>:	The number of bytes in the <DATA> field (2 bytes).
<SOURCE ID>:	Identifies the address of the equipment from where the message originated (1 byte).
<DEST. ID>:	Identifies the address of the equipment where the message is to be sent (1 byte).
<FSN>:	Frame sequence number ensures correct packet acknowledgment and data transfers (1 byte).
<OPCODE>:	This byte identifies the message type associated with the information data. The equipment processes the data according to the value in this field. Return error codes and acknowledgment are also included in this field (2 bytes).
<...DATA...>:	Information data. The number of data bytes in this field is indicated by the <BYTE COUNT> value.
<CHECKSUM>:	The modulo 256 sum of all preceding message bytes excluding the <SYNC> character (1 byte).



The Modem RLLP is not software-compatible with the following previous Radyne products: RCU5000 and DMD4500. These products may not occupy the same bus while using this protocol as equipment malfunction and loss of data may occur.

NOTE: When transmitting a packet at 9600 baud, the Remote M&C should ensure that the timeout value between characters does not exceed the time it takes to transmit 200 characters (200 msec). If this timeout value is exceeded, the equipment will timeout.

4.9.3 DMD15/DMD15L Opcode Command Set

The DMD15/DMD15L Opcode Command Set is listed below:

4.9.4 Modem Command Set

Command	Opcode
Query Modulator Configuration and Status	2400h
Query Demodulator Configuration and Status	2401h
Query Modem Drop & Insert Map	2402h
Query Modems Identification	2403h
Query Modem Control Mode	2404h
Query Modulator Latched Alarms	2405h
Query Demodulator Latched Alarms	2406h
Query Modem Latched Alarms	2407h
Query Modulator Current Alarms	2408h
Query Demodulator Current Alarms	2409h
Query Modem Current Alarms	240Ah
Query Modulator Status	240Bh
Query Demodulator Status	240Ch
Query Modem Eb/No, BER and Level	240Dh
Query Time	240Eh
Query Date	240Fh
Query Time and Date	2410h
Query Modem Summary Faults	2411h

Command	Opcode
Command Modem Control Mode	2600h
Command Modulator Configuration	2601h
Command Modulator Frequency	2602h
Command Modulator Strap Code	2603h
Command Modulator Data Rate	2604h
Command Modulator Filter Mask	2605h
Command Modulator Modulation Type	2606h
Command Modulator Convolutional Encoder	2607h
Command Modulator Differential Encoder	2608h
Command Modulator Carrier Control	2609h
Command Modulator Carrier Selection	260Ah
Command Modulator Clock Control	260Bh
Command Modulator Clock Polarity	260Ch
Command Modulator SCT Source	260Dh
Command Modulator Drop Mode	260Eh
Command Modulator Output Level	260Fh
Command Modulator Reed Solomon	2610h
Command Modulator Spectrum	2611h
Command Modulator Operating Mode	2612h
Command Modulator Scrambler Control	2613h
Command Modulator Scrambler Type	2614h
Command Modulator Framing	2615h
Command Modulator External Reference Source	2616h
Command Modulator Terrestrial Loopback	2617h
Command Modulator Baseband Loopback	2618h
Command Modulator Mode	2619h
Command Modulator External EXC Clock	261Ah
Command Modulator External Reference Frequency	261Bh
Command Modulator T1 D4 Yellow Alarm Selection	261Dh
Command Modulator Interface Type	261Eh
Command Modulator Circuit ID	261Fh
Command Force Modulator Summary Alarms	2622h
Command Data Invert	2623h

Clear Latched Alarm 1	2625h
Command AUPC Local Enable	2629h
Command AUPC Remote Enable	262Ah
Command AUPC Local CL Action	262Bh
Command AUPC Remote CL Action	262Ch
Command AUPC Tracking Rate	262Dh
Command AUPC Remote BB Loopback	262Eh
Command AUPC Remote Test 2047	262Fh
Command AUPC Eb/No	2630h
Command AUPC Minimum Power	2631h
Command AUPC Maximum Power	2632h
Command AUPC Nominal Power	2633h
Command AUPC Local Configuration	2634h
Command AUPC Remote Configuration	2635h
Command Modulator Reed Solomon N & K Codes	2636h
Command Modulator Time Mark Transfer	2638h
Command Demodulator Configuration	2A00h
Command Demodulator Frequency	2A01h
Command Demodulator Data Rate	2A02h
Command Demodulator Strap Code	2A03h
Command Demodulator Sweep Boundary	2A04h
Command Demodulator Sweep Delay	2A05h
Command Demodulator Demodulation Type	2A07h
Command Demodulator Convolutional Decoder	2A08h
Command Demodulator Differential Decoder	2A09h
Command Demodulator Reed Solomon	2A0Ah
Command Demodulator Mode	2A0Bh
Command Demodulator Filter Mask	2A0Ch
Command Demodulator Descrambler Control	2A0Dh
Command Demodulator Descrambler Type	2A0Eh
Command Demodulator Spectrum	2A0Fh
Command Demodulator Buffer Size	2A10h
Command Demodulator Buffer Clock	2A11h
Command Demodulator Buffer Clock Polarity	2A12h
Command Demodulator Insert Mode	2A13h
Command Demodulator T1 E1 Frame Source	2A15h

Command Demodulator Framing	2A16h
Command Demodulator Operating Mode	2A17h
Command Map Summary to Backward Alarm	2A18h
Command Demodulator BER Exponent	2A1Ah
Command Demodulator Circuit ID	2A1Bh
Command Demodulator Terrestrial Loopback	2A1Ch
Command Demodulator Baseband Loopback	2A1Dh
Command Demodulator IF Loopback	2A1Eh
Command Demodulator Interface Type	2A1Fh
Command Center Buffer	2A20h
Command Data Invert	2A21h
Command Force Demodulator Summary Alarm	2A22h
Command External EXC Source	2A23h
Clear Latched Alarm 1	2A24h
Clear Latched Alarm 2	2A25h
Clear Latched Alarm 3	2A26h
Clear Latched Alarm 4	2A2Eh
Command Demod Reacquisition Sweep	2A2Fh
Command Demod N & K Codes	2A32h
Command Demodulator Time Mark Transfer	2A33h
Command Drop and Insert Map Copy	2C00h
Command Drop and Insert Map	2C01h
Command Clear Latched Alarms	2C03h
Command Set Time	2C04h
Command Set Date	2C05h
Command Set Time and Date	2C06h
Clear Modem Common Latched Alarm 1	2C08h
Clear Modem Common Latched Alarm 2	2C09h
Command Modem Terminal Emulation	2C0Bh
Command Modem Terminal Baud Rate	2C0Ch
Command Configuration Copy	2C0Dh
Command Modem Eb/No Threshold	2C0Eh
Modem Soft Reset	2D00h

4.9.5 Detailed Command Descriptions

4.9.5.1 DMD15/DMD15L Modulator

Opcode: <2400h> Query a modulator's configuration and status

Query Response		
<1>	Number of nonvol bytes	
Configuration Bytes		
<1>	Mode	0 = Closed Net. 1 = IDR, 2 = IBS, 3 = D&I
<4>	Frequency	Selects the IF Frequency in Hz. The range is 50 MHz to 180 MHz for the 70/140 MHz type modems and 950 MHz to 1750 MHz for the L-Band modems.
<2>	Strap Code	Binary value
<1>	Filter Mask	0 = INTELSAT, 1 = EUTELSAT, 2 = CLOSED NET1
<4>	Data Rate	Binary value, 1 bps steps
<4>	External EXC Clock	Binary value, 1 Hz steps. 256 kHz to 10 MHz, In 8 kHz increments
<4>	External Reference	Binary value, 1 Hz steps. 256 kHz to 10 MHz, In 8 kHz increments
<1>	Freq. Reference Source	0 = Internal, 1 = External, 2 = High stability
<1>	Modulation Type	0 = QPSK, 1 = BPSK, 2 = 8PSK, 3 = 16QAM, 4 = OQPSK
<1>	Convolutional Encoder	0 = None, 1 = Viterbi 1/2 Rate, 2 = Viterbi 2/3 Rate, 3 = Viterbi 3/4 Rate, 4 = Viterbi 5/6 Rate, 5 = Viterbi 7/8 Rate, 6 = Viterbi 8/9 Rate, 7 = Sequential 1/2 Rate, 8 = Sequential 2/3 Rate, 9 = Sequential 3/4 Rate, 10 = Sequential 5/6 Rate, 11 = Sequential 7/8 Rate, 12 = Sequential 8/9 Rate, 13 = Trellis 1/2 Rate, 14 = Trellis 2/3 Rate, 15 = Trellis 3/4 Rate, 16 = Trellis 5/6 Rate, 17 = Trellis 7/8 Rate, 18 = Trellis 8/9 Rate, 19 = SEQ 3/4 Rate, 20 = TPC .793 2D, 21 = TPC .495 3D, 22 = TPC .325 3D
<1>	Reed Solomon	0 = Disable, 1 = Enable
<1>	Scrambler Control	0 = Disable, 1 = Enable
<1>	Scrambler Type	0 = None, 1 = IBS Scrm, 2 = V35_IJESS, 3 = V35_CCITT, 4 = V35_EFDATA, 5 = V35_FAIRCHILD, 6 = OM73, 7 = RS Scrambler, 8 = V35_EFRS, 9 = TPC Scrambler
<2>	Transmit Power Level	Signed value. +50 to -300 (5.0 to -30.0 dBm). The range is +5.0 to -20 dBm for the 70/140 MHz type modems and -5.0 to -30 dBm for the L-Band type modems (implied decimal point) (two's compliment).
<1>	Differential Encoder	0 = Off, 1 = On, 2 = EF Mode* *Available in uncoded QPSK modulation for compatibility.
<1>	Carrier Control	0 = Off, 1 = On
<1>	Carrier Selection	0 = Normal. 1 = CW, 2 = Dual, 3 = Offset, 4 = Pos Fir, 5 = Neg

		Fir
<1>	Spectrum	0 = Normal, 1 = Inverted
<1>	Operating Mode	0 = Normal, 1 = 2047 test
<1>	Clock Control	0 = SCTE, 1 = SCT, 2 = EXT EXC
<1>	Clock Polarity	0 = Normal, 1 = Inverted, 2 = Auto
<1>	SCT Source	0 = Internal. 1 = SCR
<1>	Framing	0 = No framing, 1 = 96K, 2 = 1/15, 3 = EF AUPC 1/15
<1>	Drop Mode	0 = Disabled, 1 = T1-D4, 2 = T1-ESF, 3 = PCM-30, 4 = PCM-30C, 5 = PCM-31, 6 = PCM-31C, 7 = SLC-96, 8 = T1 D4 S, 9 = T1 ESF S
<30>	Drop Map	Timeslots to drop organized by satellite channel
<1>	T1D4 Yellow Alarm Sel.	0 = Bit 2 equal 0 for all channels 1 = Frame 12 s-bits equal 1)
<1>	Forced Alarms	(0 = None, or else a 1 in the following bits means force) Bit 0 = Backward Alarm 1 IDR and IBS Bit 1 = Backward Alarm 2 IDR only Bit 2 = Backward Alarm 3 IDR only Bit 3 = Backward Alarm 4 IDR only Bit 4 = AIS Request Bit 5 = T1D4 Yellow Alarm. D&I Mode Bits 6 and 7 = Spares
<1>	Alarm 1 Mask	Bit 0 = Transmit processor Fault Bit 1 = Transmit output power level Fault Bit 2 = Transmit Oversample PLL lock Bit 3 = Composite clock PLL lock Bit 4 = IF synthesizer lock Bit 5 = IDR 96 PLL lock Bit 6 = RS FIFO fault Bit 7 = Mod Summary fault 0 = Mask, 1 = Allow
<1>	Alarm 2 Mask	Bit 0 = Terrestrial clock activity detect Bit 1 = Internal clock activity detect Bit 2 = Tx Sat clock activity detect Bit 3 = Tx data activity detect Bit 4 = Tx data AIS detect Bit 5 = Tx clock fallback Bit 6 & 7 = Spares

<1>	Common Alarm 1 Mask	0 = Mask, 1 = Allow Bit 0 = -12V alarm Bit 1 = +12V alarm Bit 2 = +5V alarm Bit 3 = Reserved Bit 4 = Battery Bit 5 = RAM and ROM alarm flag Bits 6 and 7 = Spares 0 = Mask, 1 = Allow
<1>	Common Alarm 2 Mask	Bit 0 = M&C processor fault Bit 1 = U IO card present, reserved in RCS10/10L mode Bit 2 = IF card present Bits 3 - 7 = Spares 0 = Mask, 1 = Allow
<11>	Tx Circuit ID	11 ASCII characters
<1>	Tx ESC Ch 1 Volume	-20 to +10 (+10 dBm to -20 dBm) (two's compliment)
<1>	Tx ESC Ch 2 Volume	-20 to +10 (+10 dBm to -20 dBm) (two's compliment)
<1>	Tx Interface Type	0 = G703-B-T1-AMI, 1 = G703-B-T1_B8ZS, 2 = G703-B-E1, 3 = G703-B-T2, 4 = G703-U-E1, 5 = G703-U-T2, 6 = G703-U-E2, 7 = RS-422, 8 = V.35, 9 = RS-232
<1>	Tx Terrestrial Loopback	0 = Disabled, 1 = Enabled
<1>	Tx Baseband Loopback	0 = Disabled, 1 = Enabled
<1>	Drop Status Mask	Bit 0 = Frame lock mask Bit 1 = Multiframe lock mask. Valid in E1 PCM30 and PCM30C Bit 2 = CRC lock mask. Valid in T1ESF, and E1 CRC enabled Bit 3 = T1 yellow alarm received mask Bit 4 = E1 FAS alarm received mask Bit 5 = E1 MFAS alarm received mask. Not valid in FAS mode Bit 6 = E1 CRC alarm received mask Bit 7 = CRC calculation error 0 = Mask, 1 = Allow
<1>	Tx RS N Code	2 - 255. Reed-Solomon code word length
<1>	Tx RS K Code	1 - 254. Reed-Solomon message length
<1>	Tx RS Depth	4 or 8
<1>	Data Invert	0 = None, 1 = Terrestrial, 2 = Baseband, 3 = Terrestrial and Baseband
<1>	BPSK Symbol Pairing	0 = Normal Pairing, 1 = Swapped Pairing
<1>	IDR Overhead Type	0 = 32K Voice. 1 = 64K Data
<1>	Terminal Emulation	0 = Adds Viewpoint. 1 = VT100, 2 = WYSE50

<1>	Terminal Baud Rate	0 = 300, 1 = 600, 2 = 1200, 3 = 2400, 4 = 4800, 5 = 9600, 6 = 19200, 7 = 38400, 8 = 150
<1>	FM Orderwire Mode	0 = Disable, 1 = Enable, 2 = FM Only
<1>	FM Orderwire Test Tone	0 = Off, 1 = On
<1>	AUPC Local Enable	0 = Off, 1 = On
<1>	AUPC Remote Enable	0 = Off, 1 = On
<1>	AUPC Local CL Action	0 = Hold, 1 = Nominal, 2 = Maximum
<1>	AUPC Remote CL Action	0 = Hold, 1 = Nominal, 2 = Maximum
<1>	AUPC Tracking Rate	0 = 0.5 dB/Min, 1 = 1.0 dB/Min, 2 = 1.5 dB/Min, 3 = 2.0 dB/Min, 4 = 2.5 dB/Min, 5 = 3.0 dB/Min, 6 = 3.5 dB/Min, 7 = 4.0 dB/Min, 8 = 4.5 dB/Min, 9 = 5.0 dB/Min, 10 = 5.5 dB/Min, 11 = 6.0 dB/min
<1>	AUPC Remote BB Loopback	0 = Disable, 1 = Enable
<1>	AUPC Remote 2047	0 = Disable, 1 = Enable
<2>	AUPC Target Eb/No	Target Eb/No at Receiver
<2>	AUPC Minimum Power	Singed value +50 to -200 with implied decimal point; 49 = +4.9 dBm (two's compliment)
<2>	AUPC Maximum Power	Singed value +50 to -200 with implied decimal point; 49 = +4.9 dBm (two's compliment)
<2>	AUPC Nominal Power	Singed value +50 to -200 with implied decimal point; 49 = +4.9 dBm (two's compliment)
<1>	Time Mark Transfer Enable	0 = Disable, 1 = Enable
<1>	Time Mark Transfer Pattern Length	Unsigned Binary (4 to 16) Inclusively
<1>	Reserved	Reserved
<1>	Reserved	Reserved
<1>	TPC Interleaver	0=Disable, 1=Enable
Status Bytes		
<1>	Control Mode	0 = Front Panel. 1 = Terminal, 2 = Computer
<1>	Revision Number	Decimal point implied

<1>	Alarm 1	Bit 0 = Transmit processor fault. 1 = Fail Bit 1 = Transmit output power level. 1 = Fail Bit 2 = Transmit Oversample PLL lock. 1 = Lock Bit 3 = Composite clock PLL lock. 1 = Lock Bit 4 = IF synthesizer lock. 1 = Lock Bit 5 = IDR 96 PLL lock. 1 = Lock Bit 6 = RS FIFO fault. 1 = Fail Bit 7 = Mod Summary fault. 1 = Fail
<1>	Alarm 2	Bit 0 = Terrestrial clock activity detect. 1 = Activity Bit 1 = Internal clock activity detect. 1 = Activity Bit 2 = Tx Sat clock activity detect. 1 = Activity Bit 3 = Tx data activity detect. 1 = Activity Bit 4 = Terrestrial AIS. Tx data AIS detect. 1 = AIS Fail Bit 5 = Tx clock fallback. 1 = Fail Bits 6 and 7 = Spares
<1>	Common Alarm 1	Bit 0 = -12V alarm. 1 = Fail Bit 1 = +12V alarm. 1 = Fail Bit 2 = +5V alarm. 1 = Fail Bit 3 = Reserved Bit 4 = Battery. 1 = Fail Bit 5 = RAM and ROM alarm flag. 1 = Fail Bits 6 and 7 = Spares
<1>	Common Alarm 2	Bit 0 = M&C processor fault. 1 = Fail Bit 1 = U IO card present. 1 = Present, reserved in RCS10/10L mode Bit 2 = IF card present. 1 = Present Bits 3 - 7 = Spares
<1>	Latched Alarm 1	Bit 0 = Transmit processor fault. 1 = Fail Bit 1 = Transmit output power level Fault. 1 = Fail Bit 2 = Transmit Oversample PLL lock Fault. 1 = Fail Bit 3 = Composite clock PLL lock Fault. 1 = Fail Bit 4 = IF synthesizer lock Fault. 1 = Fail Bit 5 = IDR 96 PLL Lock Fault. 1 = Fail Bit 6 = RS FIFO Fault. 1 = Fail Bit 7 = Mod Summary Fault. 1 = Fail
<1>	Latched Common Alarm 1	Bit 0 = -12V alarm. 1 = Fail Bit 1 = +12V alarm. 1 = Fail Bit 2 = +5V alarm. 1 = Fail Bit 3 = Reserved Bit 4 = Battery. 1 = Fail Bit 5 = RAM and ROM alarm flag. 1 = Fail Bits 6 and 7 = Spares
<1>	Latched Common Alarm 2	Bit 0 = M&C processor fault. 1 = Fail Bit 1 = U IO card present Fault. 1 = Fail, reserved in RCS10/10L mode Bit 2 = IF card present Fault. 1 = Fail Bits 3 - 7 = Spares
<1>	Drop Status	Bit 0 = Frame lock fault. 1 = Fail

		<p>Bit 1 = Multiframe lock Fault. Valid in E1 PCM30 and PCM30C. 1 = Fail</p> <p>Bit 2 = CRC lock fault. Valid in T1ESF, and E1 CRC enabled. 1 = Fail</p> <p>Bit 3 = T1 yellow alarm received. 1 = Received</p> <p>Bit 4 = E1 FAS alarm received. 1 = Received</p> <p>Bit 5 = E1 MFAS alarm received. Not valid in FAS mode. 1 = Received</p> <p>Bit 6 = E1 CRC alarm received. 1 = Received</p> <p>Bit 7 = CRC calculation error. 1 = Fail</p>
<1>	Online Flag	0 = Offline, 1 = Online
<1>	+5V Voltage	+5V. Implied decimal point. ex: 49 = +4.9 V
<1>	+12V Voltage	+12V. Implied decimal point. ex: 121 = +12.1 V
<1>	-12V Voltage	-12V. Implied decimal point and minus sign. ex: 118 = -11.8 V
<2>	Temperature	Degrees C. Implied decimal point. ex: 490 = 49.0 C (Not Implemented)
<1>	ESC Source	0 = Internal, 1 = External
<1>	Alarm 3	<p>Bit 0 = Backward Alarm 1 Transmitted</p> <p>Bit 1 = Backward Alarm 2 Transmitted</p> <p>Bit 2 = Backward Alarm 3 Transmitted</p> <p>Bit 3 = Backward Alarm 4 Transmitted</p> <p>Bits 4 - 7 = Spare</p> <p>0 = No, 1 = Yes</p>
<2>	AUPC Remote Test 2047 BER Mantessa	Binary value with implied decimal point; 795 = 7.95)
<1>	AUPC Remote Test 2047 BER Exponent	Binary value with implied sign; 6 = -6
<1>	Reserved	Ignore
<4>	Symbol Rate	Binary value, 1 sps steps
<17>	Latched Alarm 2	<p>Bit 0 = Terrestrial Clock. Activity Detect. 1 = Fail</p> <p>Bit 1 = Internal Clock. Activity Detect. 1 = Fail</p> <p>Bit 2 = Tx Sat Clock. Activity Detect. 1 = Fail</p> <p>Bit 3 = Tx Data Activity Detect. 1=Fail</p> <p>Bit 4 = Tx Data AIS Detect. 1=Fail</p> <p>Bit 5 = Tx Clock Fall Back. 1=Fail</p> <p>Bits 6 and 7 = Spares</p>
<2>	Reserved	Reserved
<17>	Latched Drop Status	<p>Bit 0 = Framelock Fault. 1=Fail</p> <p>Bit 1 = Multiframe Lock Fault. Valid in E1 PCM30 & PCM03. 1 = Fail</p> <p>Bit 2 = CRC Lock Fault. Valid in T1 ESF, & E1 CRC Enabled. 1 = Fail</p> <p>Bit 3-7 (Not Latched)</p>
<4>	Reserved	Reserved

Opcode: <240Bh> Query a Modulator's Status

Query Response		
<1>	Control Mode	0 = Front Panel. 1 = Terminal, 2 = Computer
<1>	Revision Number	Decimal point implied
<1>	Alarm 1	Bit 0 = Transmit processor fault. 1 = Fail Bit 1 = Transmit output power level. 1 = Fail Bit 2 = Transmit Oversample PLL lock. 1 = Lock Bit 3 = Composite clock PLL lock. 1 = Lock Bit 4 = IF synthesizer lock. 1 = Lock Bit 5 = IDR 96 PLL lock. 1 = Lock Bit 6 = RS FIFO fault. 1 = Fail Bit 7 = Mod Summary fault. 1 = Fail
<1>	Alarm 2	Bit 0 = Terrestrial clock activity detect. 1 = Activity Bit 1 = Internal clock activity detect. 1 = Activity Bit 2 = Tx Sat clock activity detect. 1 = Activity Bit 3 = Tx data activity detect. 1 = Activity Bit 4 = Terrestrial AIS. Tx data AIS detect. 1 = AIS Fail Bit 5 = Tx clock fallback. 1 = Fail Bits 6 and 7 = Spares
<1>	Common Alarm 1	Bit 0 = -12V alarm. 1 = Fail Bit 1 = +12V alarm. 1 = Fail Bit 2 = +5V alarm. 1 = Fail Bit 3 = Reserved Bit 4 = Battery. 1 = Fail Bit 5 = RAM and ROM alarm flag. 1 = Fail Bits 6 and 7 = Spares
<1>	Common Alarm 2	Bit 0 = M&C processor fault. 1 = Fail Bit 1 = U IO card present. 1 = Present, reserved in RCS10/10L mode Bit 2 = IF card present. 1 = Present Bits 3 - 7 = Spares
<1>	Latched Alarm 1	Bit 0 = Transmit processor fault. 1 = Fail Bit 1 = Transmit output power level Fault. 1 = Fail Bit 2 = Transmit Oversample PLL lock Fault. 1 = Fail Bit 3 = Composite clock PLL lock Fault. 1 = Fail Bit 4 = IF synthesizer lock Fault. 1 = Fail Bit 5 = IDR 96 PLL Lock Fault. 1 = Fail Bit 6 = RS FIFO Fault. 1 = Fail Bit 7 = Mod Summary Fault. 1 = Fail
<1>	Latched Common Alarm 1	Bit 0 = -12V alarm. 1 = Fail Bit 1 = +12V alarm. 1 = Fail Bit 2 = +5V alarm. 1 = Fail Bit 3 = Reserved Bit 4 = Battery. 1 = Fail Bit 5 = RAM and ROM alarm flag. 1 = Fail Bits 6 and 7 = Spares
<1>	Latched Common	Bit 0 = M&C processor fault. 1 = Fail

	Alarm 2	Bit 1 = U IO card present Fault. 1 = Fail, reserved in RCS10/10L mode Bit 2 = IF card present Fault. 1 = Fail Bits 3 - 7 = Spares
<1>	Drop Status	Bit 0 = Frame lock fault. 1 = Fail Bit 1 = Multiframe lock Fault. Valid in E1 PCM30 and PCM30C. 1 = Fail Bit 2 = CRC lock fault. Valid in T1ESF, and E1 CRC enabled. 1 = Fail Bit 3 = T1 yellow alarm received. 1 = Received Bit 4 = E1 FAS alarm received. 1 = Received Bit 5 = E1 MFAS alarm received. Not valid in FAS mode. 1 = Received Bit 6 = E1 CRC alarm received. 1 = Received Bit 7 = CRC calculation error. 1 = Fail
<1>	Online Flag	0 = Offline, 1 = Online
<1>	+5V Voltage	+5V. Implied decimal point. ex: 49 = +4.9 V
<1>	+12V Voltage	+12V. Implied decimal point. ex: 121 = +12.1 V
<1>	-12V Voltage	-12V. Implied decimal point and minus sign. ex: 118 = -11.8 V
<2>	Temperature	Degrees C. Implied decimal point. ex: 490 = 49.0 C (Not Implemented)
<1>	ESC Source	0 = Internal, 1 = External
<1>	Alarm 3	Bit 0 = Backward Alarm 1 Transmitted Bit 1 = Backward Alarm 2 Transmitted Bit 2 = Backward Alarm 3 Transmitted Bit 3 = Backward Alarm 4 Transmitted Bits 4 - 7 = Spare 0 = No, 1 = Yes
<2>	AUPC Remote Test 2047 BER Mantessa	Binary value with implied decimal point; 795 = 7.95)
<1>	AUPC Remote Test 2047 BER Exponent	Binary value with implied sign; 6 = -6
<1>	Reserved	Ignore
<4>	Symbol Rate	Binary value, 1 sps steps
<17>	Latched Alarm 2	Bit 0 = Terrestrial clock activity detect. 1 = Fail Bit 1 = Internal clock activity detect. 1 = Fail Bit 2 = Tx Sat Clock activity detect. 1 = Fail Bit 3 = Tx Data activity detect. 1 = Fail Bit 4 = Tx Data AIS detect. 1 = Fail Bit 5 = Tx clock fallback. 1 = Fail Bits 6 & 7 = Spares
<2>	Reserved	Reserved
<1>	Latched Drop Status	Bit 0 = Framelock fault. 1 = Fail Bit 1 = Multiframe lock fault. Valid in E1 PCM30 & PCM30C. 1 = Fail Bit 2 = CRC locifault. Valid in T1, ESF, and E1 CRC enabled. 1 = Fail

<4>	Reserved	Bits 3-7 (not latched) Reserved
-----	----------	------------------------------------

Opcode: <2405h> Query a modulator's latched alarms

Query Response		
<1>	Latched Alarm 1	Bit 0 = Transmit processor fault. 1 = Fail Bit 1 = Transmit output power level Fault. 1 = Fail Bit 2 = Transmit Oversample PLL lock Fault. 1 = Fail Bit 3 = Composite clock PLL lock Fault. 1 = Fail Bit 4 = IF synthesizer lock Fault. 1 = Fail Bit 5 = IDR 96 PLL Lock Fault. 1 = Fail Bit 6 = RS FIFO Fault. 1 = Fail Bit 7 = Mod Summary Fault. 1 = Fail
<1>	Latched Common Alarm 1	Bit 0 = -12V alarm. 1 = Fail Bit 1 = +12V alarm. 1 = Fail Bit 2 = +5V alarm. 1 = Fail Bit 3 = Reserved Bit 4 = Battery. 1 = Fail Bit 5 = RAM and ROM alarm flag. 1 = Fail Bits 6 and 7 = Spares
<1>	Latched Common Alarm 2	Bit 0 = M&C processor fault. 1 = Fail Bit 1 = U IO card present Fault. 1 = Fail, reserved in RCS10/10L mode Bit 2 = IF card present Fault. 1 = Fail Bits 3 - 7 = Spares
<1>	Latched Alarm 2	Bit 0 = Terrestrial clock activity detect. 1 = Fail Bit 1 = Internal clock activity detect. 1 = Fail Bit 2 = Tx Sat clock activity detect. 1 = Fail Bit 3 = Tx data activity detect. 1 = Fail Bit 4 = Tx data AIS detect. 1 = Fail Bit 5 = Tx clock fallback. 1 = Fail Bits 6-7 = Spares
<1>	Latched Drop Status	Bit 0 = Frame lock fault. 1 = Fail Bit 1 = Multiframe fault. 1 = Fail PCM30 and PCM30C. 1 = Fail Bit 2 = CRC lock fault. Valid in T1 ESF And E1, CRC enabled. 1 = Fail Bits 3-7 (Not latched)

Opcode: <2408h> Query a modulator's current alarms

Query Response		
<1>	Alarm 1	Bit 0 = Transmit processor fault. 1 = Fail

<1>	Alarm 2	<p>Bit 1 = Transmit output power level. 1 = Fail Bit 2 = Transmit Oversample PLL lock. 1 = Lock Bit 3 = Composite clock PLL lock. 1 = Lock Bit 4 = IF synthesizer lock. 1 = Lock Bit 5 = IDR 96 PLL lock. 1 = Lock Bit 6 = RS FIFO fault. 1 = Fail Bit 7 = Mod Summary fault. 1 = Fail</p> <p>Bit 0 = Terrestrial clock activity detect. 1 = Activity Bit 1 = Internal clock activity detect. 1 = Activity Bit 2 = Tx Sat clock activity detect. 1 = Activity Bit 3 = Tx data activity detect. 1 = Activity Bit 4 = Terrestrial AIS. Tx data AIS detect. 1 = AIS Fail Bit 5 = Tx clock fallback. 1 = Fail Bits 6 and 7 = Spares</p>
<1>	Drop Status	<p>Bit 0 = Frame lock fault. 1 = Fail Bit 1 = Multiframe lock Fault. Valid in E1 PCM30 and PCM30C. 1 = Fail Bit 2 = CRC lock fault. Valid in T1ESF, and E1 CRC enabled. 1 = Fail Bit 3 = T1 yellow alarm received. 1 = Received Bit 4 = E1 FAS alarm received. 1 = Received Bit 5 = E1 MFAS alarm received. Not valid in FAS mode. 1 = Received Bit 6 = E1 CRC alarm received. 1 = Received Bit 7 = CRC calculation error. 1 = Fail</p>
<1>	Common Alarm 1	<p>Bit 0 = -12V alarm. 1 = Fail Bit 1 = +12V alarm. 1 = Fail Bit 2 = +5V alarm. 1 = Fail Bit 3 = Reserved Bit 4 = Battery. 1 = Fail Bit 5 = RAM and ROM alarm flag. 1 = Fail Bits 6 and 7 = Spares</p>
<1>	Common Alarm 2	<p>Bit 0 = M&C processor fault. 1 = Fail Bit 1 = U IO card present. 1 = Present, reserved in RCS10/10L mode Bit 2 = IF card present. 1 = Present Bits 3 - 7 = Spares</p>

Opcode: <2600h> Command a modem's control mode

<1>	Modem control mode	0 = Front panel. 1 = Terminal, 2 = Computer
-----	--------------------	---

Opcode: <2601h> Command a modulator's configuration

<1>	Mode	0 = Closed Net. 1 = IDR, 2 = IBS, 3 = D&I
<4>	Frequency	Selects the IF Frequency in Hz. The range is 50 MHz to 180 MHz for the 70/140 MHz type modems and 950 MHz to 1750 MHz for the L-Band modems.
<2>	Strap Code	Binary value
<1>	Filter Mask	0 = INTELSAT, 1 = EUTELSAT, 2 = CLOSED NET1
<4>	Data Rate	Binary value, 1 bps steps

<4>	External EXC Clock	Binary value, 1 Hz steps. 256 kHz to 10 MHz, In 8 kHz increments
<4>	External Reference	Binary value, 1 Hz steps. 256 kHz to 10 MHz, In 8 kHz increments
<1>	Freq. Reference Source	0 = Internal, 1 = External, 2 = High stability
<1>	Modulation Type	0 = QPSK, 1 = BPSK, 2 = 8PSK, 3 = 16QAM, 4 = OQPSK
<1>	Convolutional Encoder	0 = None, 1 = Viterbi 1/2 Rate, 2 = Viterbi 2/3 Rate, 3 = Viterbi 3/4 Rate, 4 = Viterbi 5/6 Rate, 5 = Viterbi 7/8 Rate, 6 = Viterbi 8/9 Rate, 7 = Sequential 1/2 Rate, 8 = Sequential 2/3 Rate, 9 = Sequential 3/4 Rate, 10 = Sequential 5/6 Rate, 11 = Sequential 7/8 Rate, 12 = Sequential 8/9 Rate, 13 = Trellis 1/2 Rate, 14 = Trellis 2/3 Rate, 15 = Trellis 3/4 Rate, 16 = Trellis 5/6 Rate, 17 = Trellis 7/8 Rate, 18 = Trellis 8/9 Rate, 19 = SEQ 3/4 Rate, 20 = TPC .793 2D, 21 = TPC .495 3D, 22 = TPC .325 3D
<1>	Reed Solomon	0 = Disable, 1 = Enable
<1>	Scrambler Control	0 = None, 1 = IBS Scrm, 2 = V35_IESS, 3 = V35_CCITT, 4 = V35_EFDATA, 5 = V35_FAIRCHILD, 6 = OM73, 7 = RS Scrambler, 8 = V35_EFRS, 9 = TPC Scrambler
<1>	Scrambler Type	
<2>	Transmit Power Level	Signed value. +50 to -300 (5.0 to -30.0 dBm). The range is +5.0 to -20 dBm for the 70/140 MHz type modems and -5.0 to -30 dBm for the L-Band type modems (implied decimal point) (two's compliment).
<1>	Differential Encoder	0 = Off, 1 = On, 2 = EF Mode* *Available in uncoded QPSK modulation for compatibility.
<1>	Carrier Control	0 = Off, 1 = On
<1>	Carrier Selection	0 = Normal. 1 = CW, 2 = Dual, 3 = Offset, 4 = Pos Fir, 5 = Neg Fir
<1>	Spectrum	0 = Normal, 1 = Inverted
<1>	Operating Mode	0 = Normal, 1 = 2047 test
<1>	Clock Control	0 = SCTE, 1 = SCT, 2 = EXT EXC
<1>	Clock Polarity	0 = Normal, 1 = Inverted, 2 = Auto
<1>	SCT Source	0 = Internal. 1 = SCR
<1>	Framing	0 = No framing, 1 = 96K, 2 = 1/15, 3 = EF AUPC 1/15
<1>	Drop Mode	0 = Disabled, 1 = T1-D4, 2 = T1-ESF, 3 = PCM-30, 4 = PCM-30C, 5 = PCM-31, 6 = PCM-31C, 7 = SLC-96, 8 = T1 D4 S, 9 = T1 ESF S

<30>	Drop Map	Timeslots to drop organized by satellite channel
<1>	T1D4 Yellow Alarm Sel.	0 = Bit 2 equal 0 for all channels 1 = Frame 12 s-bits equal 1)
<1>	Forced Alarms	(0 = None, or else a 1 in the following bits means force) Bit 0 = Backward Alarm 1 IDR and IBS Bit 1 = Backward Alarm 2 IDR only Bit 2 = Backward Alarm 3 IDR only Bit 3 = Backward Alarm 4 IDR only Bit 4 = AIS Request Bit 5 = T1D4 Yellow Alarm. D&I Mode Bits 6 and 7 = Spares
<1>	Alarm 1 Mask	Bit 0 = Transmit processor Fault Bit 1 = Transmit output power level Fault Bit 2 = Transmit Oversample PLL lock Bit 3 = Composite clock PLL lock Bit 4 = IF synthesizer lock Bit 5 = IDR 96 PLL lock Bit 6 = RS FIFO fault Bit 7 = Mod Summary fault 0 = Mask, 1 = Allow
<1>	Alarm 2 Mask	Bit 0 = Terrestrial clock activity detect Bit 1 = Internal clock activity detect Bit 2 = Tx Sat clock activity detect Bit 3 = Tx data activity detect Bit 4 = Tx data AIS detect Bit 5 = Tx clock fallback Bit 6 & 7 = Spares 0 = Mask, 1 = Allow
<1>	Common Alarm 1 Mask	Bit 0 = -12V alarm Bit 1 = +12V alarm Bit 2 = +5V alarm Bit 3 = Reserved Bit 4 = Battery Bit 5 = RAM and ROM alarm flag Bits 6 and 7 = Spares 0 = Mask, 1 = Allow
<1>	Common Alarm 2 Mask	Bit 0 = M&C processor fault Bit 1 = U IO card present, reserved in RCS10/10L mode Bit 2 = IF card present Bits 3 - 7 = Spares 0 = Mask, 1 = Allow
<11>	Tx Circuit ID	11 ASCII characters
<1>	Tx ESC Ch 1 Volume	-20 to +10 (+10 dBm to -20 dBm) (two's compliment)

<1>	Tx ESC Ch 2 Volume	-20 to +10 (+10 dBm to -20 dBm) (two's compliment)
<1>	Tx Interface Type	0 = G703-B-T1-AMI, 1 = G703-B-T1_B8ZS, 2 = G703-B-E1, 3 = G703-B-T2, 4 = G703-U-E1, 5 = G703-U-T2, 6 = G703-U-E2, 7 = RS-422, 8 = V.35, 9 = RS-232
<1>	Tx Terrestrial Loopback	0 = Disabled, 1 = Enabled
<1>	Tx Baseband Loopback	0 = Disabled, 1 = Enabled
<1>	Drop Status Mask	Bit 0 = Frame lock mask Bit 1 = Multiframe lock mask. Valid in E1 PCM30 and PCM30C Bit 2 = CRC lock mask. Valid in T1ESF, and E1 CRC enabled Bit 3 = T1 yellow alarm received mask Bit 4 = E1 FAS alarm received mask Bit 5 = E1 MFAS alarm received mask. Not valid in FAS mode Bit 6 = E1 CRC alarm received mask Bit 7 = CRC calculation error 0 = Mask, 1 = Allow
<1>	Tx RS N Code	2 - 255. Reed-Solomon code word length
<1>	Tx RS K Code	1 - 254. Reed-Solomon message length
<1>	Tx RS Depth	4 or 8
<1>	Data Invert	0 = None, 1 = Terrestrial, 2 = Baseband, 3 = Terrestrial and Baseband
<1>	BPSK Symbol Pairing	0 = Normal Pairing, 1 = Swapped Pairing
<1>	IDR Overhead Type	0 = 32K Voice. 1 = 64K Data
<1>	Terminal Emulation	0 = Adds Viewpoint. 1 = VT100, 2 = WYSE50
<1>	Terminal Baud Rate	0 = 300, 1 = 600, 2 = 1200, 3 = 2400, 4 = 4800, 5 = 9600, 6 = 19200, 7 = 38400, 8 = 150
<1>	FM Orderwire Mode	0 = Disable, 1 = Enable, 2 = FM Only
<1>	FM Orderwire Test Tone	0 = Off, 1 = On
<1>	AUPC Local Enable	0 = Off, 1 = On
<1>	AUPC Remote Enable	0 = Off, 1 = On
<1>	AUPC Local CL Action	0 = Hold, 1 = Nominal, 2 = Maximum
<1>	AUPC Remote CL Action	0 = Hold, 1 = Nominal, 2 = Maximum
<1>	AUPC Tracking Rate	0 = 0.5 dB/Min, 1 = 1.0 dB/Min, 2 = 1.5 dB/Min, 3 = 2.0 dB/Min,

<1>		4 = 2.5 dB/Min, 5 = 3.0 dB/Min, 6 = 3.5 dB/Min, 7 = 4.0 dB/Min, 8 = 4.5 dB/Min, 9 = 5.0 dB/Min, 10 = 5.5 dB/Min, 11 = 6.0 dB/min
<1>	AUPC Remote BB Loopback	0 = Disable, 1 = Enable
<1>	AUPC Remote 2047	0 = Disable, 1 = Enable
<2>	AUPC Target Eb/No	Target Eb/No at Receiver
<2>	AUPC Minimum Power	Singed value +50 to -200 with implied decimal point; 49 = +4.9 dBm (two's compliment)
<2>	AUPC Maximum Power	Singed value +50 to -200 with implied decimal point; 49 = +4.9 dBm (two's compliment)
<2>	AUPC Nominal Power	Singed value +50 to -200 with implied decimal point; 49 = +4.9 dBm (two's compliment)
<1>	Time Mark Transfer Enable	0 = Disable, 1 = Enable
<1>	Time Mark Transfer Pattern Length	Unsigned Binary (4 to 16) Inclusively
<1>	Reserved	Reserved
<1>	Reserved	Reserved
<1>	TPC Interleaver	0 = Disable, 1 = Enable

Opcode: <2602h> Command a modulator's frequency

<4>	Frequency	Selects the IF Frequency in Hz. The range is 50 MHz to 180 MHz for the 70/140 MHz type modems and 950 MHz to 1750 MHz for the L-Band modems. Note: This command also turns the carrier off to protect the satellite.
-----	-----------	--

Opcode: <2603h> Command a modulator's strap code

<2>	Strap Code	Binary value Note: This command also turns the carrier off to protect the satellite.
-----	------------	--

Opcode: <2604h> Command a modulator's data rate

<4>	Data Rate	Binary value, 1 bps steps Note: This command also turns the carrier off to protect the satellite.
-----	-----------	---

Opcode: <2605h> Command a modulator's filter mask

<1>	Filter Mask	0 = INTELSAT, 1 = EUTELSAT, 2 = CLOSED NET1
-----	-------------	---

Opcode: <2606h> Command a modulator's modulation type

<1>	Modulation Type	0 = QPSK, 1 = BPSK, 2 = 8PSK, 3 = 16QAM, 4 = OQPSK
-----	-----------------	--

Opcode: <2607h> Command a modulator's convolutional encoder

<1>	Convolutional Encoder	0 = None, 1 = Viterbi 1/2 Rate, 2 = Viterbi 2/3 Rate, 3 = Viterbi 3/4 Rate, 4 = Viterbi 5/6 Rate, 5 = Viterbi 7/8 Rate, 6 = Viterbi 8/9 Rate, 7 = Sequential 1/2 Rate, 8 = Sequential 2/3 Rate, 9 = Sequential 3/4 Rate, 10 = Sequential 5/6 Rate, 11 = Sequential 7/8 Rate, 12 = Sequential 8/9 Rate, 13 = Trellis 1/2 Rate, 14 = Trellis 2/3 Rate, 15 = Trellis 3/4 Rate, 16 = Trellis 5/6 Rate, 17 = Trellis 7/8 Rate, 18 = Trellis 8/9 Rate, 19 = SEQ 3/4 Rate, 20 = TPC .793 2D, 21 = TPC .495 3D, 22 = TPC .325 3D Note: This command also turns the carrier off to protect the satellite.
-----	-----------------------	--

Opcode: <2608h> Command a modulator's differential encoder

<1>	Differential Encoder	0 = Off, 1 = On, 2 = EF Mode* *Available in uncoded QPSK modulation for compatibility.
-----	----------------------	---

Opcode: <2609h> Command a modulator's carrier control

<1>	Carrier Control	0 = Off, 1 = On
-----	-----------------	-----------------

Opcode: <260Ah> Command a modulator's carrier selection

<1>	Carrier Selection	0 = Normal. 1 = CW, 2 = Dual, 3 = Offset, 4 = Pos Fir, 5 = Neg Fir
-----	-------------------	--

Opcode: <260Bh> Command a modulator's clock control

<1>	Clock Control	0 = SCTE, 1 = SCT, 2 = EXT EXC
-----	---------------	--------------------------------

Opcode: <260Ch> Command a modulator's clock polarity

<1>	Clock Polarity	0 = Normal, 1 = Inverted, 2 = Auto
-----	----------------	------------------------------------

Opcode: <260Dh> Command a modulator's SCT source

<1>	SCT Source	0 = Internal. 1 = SCR
-----	------------	-----------------------

Opcode: <260Eh> Command a modulator's drop mode

<1>	Drop Mode	0 = Disabled, 1 = T1-D4, 2 = T1-ESF, 3 = PCM-30, 4 = PCM-30C, 5 = PCM-31, 6 = PCM-31C, 7 = SLC-96, 8 = T1 D4 S, 9 = T1 ESF S
-----	-----------	--

Opcode: <260Fh> Command a modulator's output level

<2>	Transmit Power Level	Signed value. +50 to -300 (5.0 to -30.0 dBm). The range is +5.0 to -20 dBm for the 70/140 MHz type modems and -5.0 to -30 dBm for the L-Band type modems (implied decimal point) (two's complement).
-----	----------------------	--

Opcode: <2610h> Command a modulator's Reed Solomon

<1>	Reed Solomon	0 = Disable, 1 = Enable
-----	--------------	-------------------------

Opcode: <2611h> Command a modulator's spectrum

<1>	Spectrum	0 = Normal, 1 = Inverted
-----	----------	--------------------------

Opcode: <2612h> Command a modulator's operating mode

<1>	Operating Mode	0 = Normal, 1 = 2047 test
-----	----------------	---------------------------

Opcode: <2613h> Command a modulator's scrambler control

<1>	Scrambler Control	0 = Disable, 1 = Enable
-----	-------------------	-------------------------

Opcode: <2614h> Command a modulator's scrambler type

<1>	Scrambler Type	0 = None, 1 = IBS Scrm, 2 = V35_IESS, 3 = V35_CCITT, 4 = V35_EFDATA, 5 = V35_FAIRCHILD, 6 = OM73, 7 = RS Scrambler, 8 = V35_EFRS, 9 = TPC Scrambler
-----	----------------	---

Opcode: <2615h> Command a modulator's framing

<1>	Framing	0 = No framing, 1 = 96K, 2 = 1/15, 3 = EF AUPC 1/15
-----	---------	---

Opcode: <2616h> Command a modem's external reference source

<1>	External Reference Source	0 = Internal, 1 = External, 2 = High stability
-----	---------------------------	--

Opcode: <2617h> Command a modulator's terrestrial loopback

<1>	Tx Terrestrial Loopback	0 = Disabled, 1 = Enabled
-----	-------------------------	---------------------------

Opcode: <2618h> Command a modulator's baseband loopback

<1>	Tx Baseband Loopback	0 = Disabled, 1 = Enabled
-----	----------------------	---------------------------

Opcode: <2619h> Command a modulator's mode

<1>	Mode	0 = Closed Net. 1 = IDR, 2 = IBS, 3 = D&I
-----	------	---

Opcode: <261Ah> Command a modem's external EXC clock

<4>	External EXC Clock	Binary value, 1 Hz steps. 256 kHz to 10 MHz, In 8 kHz increments
-----	--------------------	--

Opcode: <261Bh> Command a modem's external reference frequency

<4>	External Reference Frequency	Binary value, 1 Hz steps. 256 kHz to 10 MHz, In 8 kHz increments
-----	------------------------------	--

Opcode: <261Dh> Command a modulator's T1D4 Yellow alarm selection

<1>	T1D4 Yellow Alarm Sel.	0 = Bit 2 equal 0 for all channels 1 = Frame 12 s-bits equal 1
-----	------------------------	---

Opcode: <261Eh> Command a modulator's interface type

<1>	Tx Interface Type	0 = G703-B-T1-AMI, 1 = G703-B-T1_B8ZS, 2 = G703-B-E1, 3 = G703-B-T2, 4 = G703-U-E1, 5 = G703-U-T2, 6 = G703-U-E2, 7 = RS-422, 8 = V.35, 9 = RS-232
-----	-------------------	--

Opcode: <261Fh> Command a modulator's circuit ID

<11>	Tx Circuit ID	11 ASCII characters
------	---------------	---------------------

Opcode: <2622h> Command Force Mod Summary Alarms

<1>	Summary Alarm	0 = Do not force. 1 = Force
-----	---------------	-----------------------------

Opcode: <2623h> Command Data Invert

<1>	Data Invert	0 = None, 1 = Terrestrial, 2 = Baseband, 3 = Terrestrial and Baseband
-----	-------------	---

Opcode: <2625h> Clear Latched Alarm 1 (No Data)

Opcode: <2629h> Command AUPC Local Enable

<1>	AUPC Local Enable	0 = Off, 1 = On
-----	-------------------	-----------------

Opcode: <262Ah> Command AUPC Remote Enable

<1>	AUPC Remote Enable	0 = Off, 1 = On
-----	--------------------	-----------------

Opcode: <262Bh> Command AUPC Local CL Action

<1>	AUPC Local CL Action	0 = Hold, 1 = Nominal, 2 = Maximum
-----	----------------------	------------------------------------

Opcode: <262Ch> Command AUPC Remote CL Action

<1>	AUPC Remote CL Action	0 = Hold, 1 = Nominal, 2 = Maximum
-----	-----------------------	------------------------------------

Opcode: <262Dh> Command AUPC Tracking Rate

<1>	AUPC Tracking Rate	0 = 0.5 dB/Min, 1 = 1.0 dB/Min, 2 = 1.5 dB/Min, 3 = 2.0 dB/Min, 4 = 2.5 dB/Min, 5 = 3.0 dB/Min, 6 = 3.5 dB/Min, 7 = 4.0 dB/Min, 8 = 4.5 dB/Min, 9 = 5.0 dB/Min, 10 = 5.5 dB/Min, 11 = 6.0 dB/min
-----	--------------------	--

Opcode: <262Eh> Command AUPC Remote Baseband Loopback

<1>	AUPC Remote BB Loopback	0 = Disable, 1 = Enable
-----	-------------------------	-------------------------

Opcode: <262Fh> Command AUPC Remote Test 2047

<1>	AUPC Remote 2047	0 = Disable, 1 = Enable
-----	------------------	-------------------------

Opcode: <2630h> Command AUPC Eb/No

<2>	AUPC Target Eb/No	Target Eb/No at Receiver
-----	-------------------	--------------------------

Opcode: <2631h> Command AUPC Minimum Power

<2>	AUPC Minimum Power	Singed value +50 to -200 with implied decimal point; 49 = +4.9 dBm (two's compliment)
-----	--------------------	---

Opcode: <2632h> Command AUPC Maximum Power

<2>	AUPC Maximum Power	Singed value +50 to -200 with implied decimal point; 49 = +4.9 dBm (two's compliment)
-----	--------------------	---

Opcode: <2633h> Command AUPC Nominal Power

<2>	AUPC Nominal Power	Singed value +50 to -200 with implied decimal point; 49 = +4.9 dBm (two's compliment)
-----	--------------------	---

Opcode: <2634h> Command AUPC Local Configuration

<1>	AUPC Local Enable	0 = Off, 1 = On
<1>	AUPC Local CL Action	0 = Hold, 1 = Nominal, 2 = Maximum
<1>	AUPC Tracking Rate	0 = 0.5 dB/Min, 1 = 1.0 dB/Min, 2 = 1.5 dB/Min, 3 = 2.0 dB/Min, 4 = 2.5 dB/Min, 5 = 3.0 dB/Min, 6 = 3.5 dB/Min, 7 = 4.0 dB/Min, 8 = 4.5 dB/Min, 9 = 5.0 dB/Min, 10 = 5.5 dB/Min, 11 = 6.0 dB/min
<1>	AUPC Remote CL Action	0 = Hold, 1 = Nominal, 2 = Maximum
<2>	AUPC Target Eb/No	Target Eb/No at Receiver
<2>	AUPC Minimum	Singed value +50 to -200 with implied decimal point; 49 = +4.9

	Power	dBm (two's compliment)
<2>	AUPC Maximum Power	Singed value +50 to -200 with implied decimal point; 49 = +4.9 dBm (two's compliment)
<2>	AUPC Nominal Power	Singed value +50 to -200 with implied decimal point; 49 = +4.9 dBm (two's compliment)

Opcode: <2635h> Command AUPC Remote Configuration

<1>	AUPC Remote Enable	0 = Off, 1 = On
<1>	AUPC Remote BB Loopback	0 = Disable, 1 = Enable
<1>	AUPC Remote 2047	0 = Disable, 1 = Enable

Opcode: <2636h> Command Modulator Reed Solomon N & K Codes and Interleaver Depth

<1>	Tx RS N Code	2 - 255. Reed-Solomon code word length
<1>	Tx RS K Code	1 - 254. Reed-Solomon message length
<1>	Tx RS Depth	4 or 8 Reed-Solomon Interleaver Depth

Opcode: <2638h> Command a modulator's Time Mark Transfer

<1>	Time Mark Transfer Enable	0 = Disable, 1 = Enable
<1>	Time Mark Transfer Pattern Length	Unsigned Binary (4 to 16) Inclusively

4.9.5.2 DMD15/DMD15L Demodulator**Opcode: <2401h>** Query a demodulator's configuration and status

Query Response		
<1>	Number of nonvol bytes	
Configuration Bytes		
<1>	Mode	0 = Closed Net. 1 = IDR, 2 = IBS, 3 = D&I
<4>	Frequency	Selects the IF frequency in Hz. The range is 50 MHz to 180 MHz for the 70/140 MHz type modems and 950 MHz to 1750 MHz for the L-Band Modems.
<2>	Sweep Delay	Unsigned binary value, decimal point implied, 0.1 second steps 0.0 – 900.0
<4>	Data Rate	Binary value, 1 bps steps
<1>	Sweep Boundary	Sweep limits. Max of ± 32 kHz in kHz steps 1 - 32
<1>	Input Level Limit	Lower level limit, binary value, 1 dB steps. Reserved
<2>	Strap Code	Binary value
<1>	Filter Mask	0 = INTELSAT, 1 = EUTELSAT, 2 = CLOSED NET1

<1>	Demodulation Type	0 = QPSK, 1 = BPSK, 2 = 8PSK, 3 = 16QAM, 4 = OQPSK
<1>	Convolutional Decoder	0 = None, 1 = Viterbi 1/2 Rate, 2 = Viterbi 2/3 Rate, 3 = Viterbi 3/4 Rate, 4 = Viterbi 5/6 Rate, 5 = Viterbi 7/8 Rate, 6 = Viterbi 8/9 Rate, 7 = Sequential 1/2 Rate, 8 = Sequential 2/3 Rate, 9 = Sequential 3/4 Rate, 10 = Sequential 5/6 Rate, 11 = Sequential 7/8 Rate, 12 = Sequential 8/9 Rate, 13 = Trellis 1/2 Rate, 14 = Trellis 2/3 Rate, 15 = Trellis 3/4 Rate, 16 = Trellis 5/6 Rate, 17 = Trellis 7/8 Rate, 18 = Trellis 8/9 Rate, 19 = SEQ 3/4 Rate, 20 = TPC .793 2D, 21 = TPC .495 3D, 22 = TPC .325 3D
<1>	Reed Solomon	0 = Disable, 1 = Enable
<1>	Differential Decoder	0 = Off, 1 = On, 2 = EF Mode* *Available in uncoded QPSK modulation for compatibility.
<1>	Descrambler Control	0 = Disable, 1 = Enable
<1>	Descrambler Type	0 = None, 1 = IBS Scrm., 2 = V35_IESS, 3 = V35_CCITT, 4 = V35_EFDATA, 5 = V35_FAIRCHILD, 6 = OM73, 7 = RS Descrambler, 8 = V.35 EF RS Descrambler, 9 = TPC Scrambler
<1>	Spectrum	0 = Normal, 1 = Inverted
<1>	Buffer Size Msec	Indicates buffer size in msec. 0 through 32
<1>	Buffer Clock	0 = SCTE, 1 = SCT, 2 = EXT EXC, 3 = RX SAT
<1>	Buffer Clock Polarity	0 = Normal, 1 = Inverted
<1>	Insert Mode	0 = Disabled, 1 = T1-D4, 2 = T1-ESF, 3 = PCM-30, 4 = PCM-30C, 5 = PCM-31, 6 = PCM-31C, 7 = SLC-96, 8 = T1 D4 S, 9 = T1 ESF S
<1>	T1E1 Frame Source	0 = Internal, 1 = External
<30>	Insert Map	Timeslots to insert organized by satellite channel
<1>	Framing	0 = No framing, 1 = 96K, 2 = 1/15, 3 = EF AUPC 1/15
<1>	Operating Mode	0 = Stop, 1 = 2047 test
<1>	Map Summary To Backward Alarm	0 = None, 1 = BK1, 2 = BK2, 3 = BK1 & 2, 4 = BK3, 5 = BK1 & 3, 6 = BK2 & 3, 7 = BK1, 2 & 3, 8 = BK4, 9 = BK1 & 4, 10 = BK2 & 4, 11 = BK1, 2 & 4, 12 = BK3 & 4, 13 = BK1, 3 & 4, 14 = BK2, 3 & 4, 15 = BK1, 2, 3 & 4
<1>	Forced Alarms	0 = None, 1 = Send the Alarm Bits 0 – 7 = Spares
<1>	Alarm 1 Mask	Bit 0 = Rx proc Bit 1 = Carrier Loss Bit 2 = Multiframe Sync Loss Bit 3 = Frame Sync Loss Bit 4 = IBS BER Alarm

<1>	Alarm 2 Mask	<p>Bit 5 = Satellite AIS Bit 6 = Rx Data Activity Bit 7 = Rx AGC Level 0 = Mask, 1 = Allow</p> <p>Bit 0 = Buffer underflow Bit 1 = Buffer overflow Bit 2 = Buffer under 10% Bit 3 = Buffer over 90% Bit 4 = RS Decoder Lock Fault Bit 5 = RS De-Interleaver Fault Bit 6 = RS Decoder Uncorrectable Word Bit 7 = Summary Fault 0 = Mask, 1 = Allow</p>
<1>	Alarm 3 Mask	<p>Bit 0 = IF synthesizer lock detect Bit 1 = Rx Oversample PLL lock detect Bit 2 = Buffer clock PLL lock detect Bit 3 = Viterbi decoder lock Bit 4 = Sequential decoder lock Bit 5 = Rx 2047 test pattern lock Bit 6 = External reference PLL lock Bit 7 = IDR 96K PLL Lock 0 = Mask, 1 = Allow</p>
<1>	Alarm 4 Mask	<p>Bit 0 = Buffer clock activity detect Bit 1 = External BNC activity detect, reserved in RCS10/10L mode Bit 2 = Rx satellite clock activity detect Bit 3 = Insert clock activity detect Bit 4 = External reference PLL activity, reserved in RCS10/10L mode Bit 5 = High Stability reference PLL activity, reserved in RCS10/10L mode Bit 6 = Rx clock fallback Bit 7 = Eb/No Threshold 0 = Mask, 1 = Allow</p>
<1>	Common Alarm 1 Mask	<p>Bit 0 = -12V alarm Bit 1 = +12V alarm Bit 2 = +5V alarm Bit 3 = Reserved Bit 4 = Battery Bit 5 = RAM and ROM alarm flag Bits 6 and 7 = Spares 0 = Mask, 1 = Allow</p>
<1>	Common Alarm 2 Mask	<p>Bit 0 = M&C processor fault Bit 1 = U IO card present, reserved in RCS10/10L mode Bit 2 = IF card present Bits 3 - 7 = Spares 0 = Mask, 1 = Allow</p>
<1>	ESC Channel 1 Volume	<p>Binary value, valid in IDR only, +10 dBm to -20 dBm (two's complement)</p> <p>Binary value, valid in IDR only, +10 dBm to -20 dBm (two's</p>

<1>	ESC Channel 2 Volume	compliment) 6 through 9 for Viterbi, 5 through 7 for Sequential
<1>	BER Exponent	11 ASCII characters
<11>	Rx Circuit ID	0 = Disabled, 1 = Enabled
<1>	Rx Terrestrial Loopback	0 = Disabled, 1 = Enabled
<1>	Rx Baseband Loopback	0 = Disabled, 1 = Enabled
<1>	Rx IF Loopback	0 = G703-B-T1-AMI, 1 = G703-B-T1_B8ZS, 2 = G703-B-E1, 3 = G703-B-T2, 4 = G703-U-E1, 5 = G703-U-T2, 6 = G703-U-E2, 7 = RS-422, 8 = V.35, 9 = RS-232
<1>	Rx Interface Type	
<1>	Insert Status Mask	Bit 0 = Frame lock Bit 1 = Multiframe lock. Valid in E1 PCM30 and PCM30C Bit 2 = CRC lock. Valid in T1ESF, and E1 CRC enabled Bit 3 = T1 yellow alarm received Bit 4 = E1 FAS alarm received Bit 5 = E1 MFAS alarm received. Not valid in FAS mode Bit 6 = E1 CRC alarm received Bit 7 = CRC calculation error 0 = Mask, 1 = Allow
<1>	Rx Reed Solomon N Code	2 - 255 Reed-Solomon code word length
<1>	Rx Reed Solomon K Code	1 - 254 Reed-Solomon message length
<1>	Rx Reed Solomon Depth	4 or 8
<1>	External Clock Source	0 = BNC EXC, 1 = Balanced EXC, 2 = IDI, 3 = SYS [RCS10 Only]
<1>	Data Invert	0 = None, 1 = Terrestrial, 2 = Baseband 3 = Terrestrial and Baseband
<1>	Alarm 5 Masks	Bit 0 = Trellis Decoder Lock Bit 1 = FM DSP Lock Mask Bit 2 = T1 signaling fault Bit 3 = Turbo Codec Lock Fault Bits 4 - 7 = Spares 0 = Mask, 1 = Allow
<1>	BPSK Symbol Pairing	0 = Normal, 1 = Swapped
<1>	ES Mode	0 = Normal, 1 = Enhanced
<1>	ES Type	0 = RS-232, 1 = RS-485
<1>		0 = 150, 1 = 300, 2 = 600, 3 = 1200, 4 = 2400, 5 = 4800, 6 = 9600

<1>	ES Baud	0 = 7 Bits. 1 = 8 Bits
<1>	ES Data Bits	0 = 32K Voice. 1 = 64K Data
<1>	IDR Overhead Type	0 = Disable, 1 = Enable, 2 = FM Only
<1>	FM Orderwire Mode	Unsigned Binary (4 to 16) Inclusively
<1>	Time Mark Transfer Pattern Length	<i>Unsigned Binary Value, 0-99, Implied Decimal Point</i> 0.0 - 9.9 dB
<2>	Eb/No Threshold	Unsigned binary value Sweep limits. Max of +/- 32000 Hz in 1 Hz steps 0 – 32000
<2>	Reacquisition Sweep Boundary	
<3>	Reserved	Reserved
<1>	TPC Deinterleaver	0=Disable, 1=Enable
Status Bytes		
<1>	Control Mode	0 = Front Panel. 1 = Terminal, 2 = Computer
<1>	Revision Number	Decimal point implied
<1>	Alarm 1	Bit 0 = Receive processor fault. 1 = Fail Bit 1 = Carrier Loss. 0 = pass. 1 = Fail Bit 2 = Multiframe Sync Loss 0 = pass. 1 = Fail Bit 3 = Frame Sync Loss 0 = pass. 1 = Fail Bit 4 = IBS BER Alarm 0 = pass. 1 = Fail Bit 5 = Satellite AIS 0 = pass. 1 = Fail Bit 6 = Rx Data Activity. 1 = Activity Bit 7 = RX AGC Level. 0 = Pass, 1 = Fail
<1>	Alarm 2	Bit 0 = Buffer underflow. 0 = OK. 1 = Underflow Bit 1 = Buffer overflow. 0 = OK. 1 = Overflow Bit 2 = Buffer under 10%. 1 = Under 10% Bit 3 = Buffer over 90%. 1 = Over 90% Bit 4 = RS Decoder Lock Fault. 1 = Fail Bit 5 = RS De-Interleaver Fault. 1 = Fail Bit 6 = RS Decoder Uncorrectable Word. 1 = Fail Bit 7 = Summary Fault. 1 = Fail
<1>	Alarm 3	Bit 0 = IF synthesizer lock detect. 1 = Lock Bit 1 = Rx Oversample PLL lock detect. 1 = Lock Bit 2 = Buffer clock PLL lock detect. 1 = Lock Bit 3 = Viterbi decoder lock. 1 = Lock Bit 4 = Sequential decoder lock. 1 = Lock Bit 5 = Rx 2047 test pattern lock. 1 = Lock Bit 6 = External reference PLL lock. 1 = Lock Bit 7 = IDR 96K PLL Lock. 1 = Lock

<1>	Alarm 4	Bit 0 = Buffer clock activity detect. 1 = Activity Bit 1 = External BNC activity detect. 1 = Activity, reserved in RCS10/10L mode Bit 2 = Rx satellite clock activity detect. 1 = Activity Bit 3 = Insert clock activity detect. 1 = Activity Bit 4 = External reference PLL activity. 1 = Activity, reserved in RCS10/10L mode Bit 5 = High Stability reference PLL activity. 1 = Activity, reserved in RCS10/10L mode Bit 6 = Rx clock fallback. 1 = Fail Bit 7 = Eb/No Threshold, 1 = Fail
<1>	Common Alarm 1	Bit 0 = -12V alarm. 1 = Fail Bit 1 = +12V alarm. 1 = Fail Bit 2 = +5V alarm. 1 = Fail Bit 3 = Reserved Bit 4 = Battery. 1 = Fail Bit 5 = RAM and ROM alarm flag. 1 = Fail Bits 6 and 7 = Spares
<1>	Common Alarm 2	Bit 0 = M&C processor fault. 1 = Fail Bit 1 = U IO card present. 1 = Present, reserved in RCS10/10L mode Bit 2 = IF card present. 1 = Present Bits 3 - 7 = Spares
<1>	Latched Alarm 1	Bit 0 = Receive processor fault Alarm. 1 = Fail Bit 1 = Carrier Loss 1 = Fail Bit 2 = Multiframe Sync Loss 1 = Fail Bit 3 = Frame Sync Loss 1 = Fail Bit 4 = IBS BER Alarm 1 = Fail Bit 5 = Satellite AIS 1 = Fail Bit 6 = Rx Data Activity. 1 = Fail Bit 7 = Rx AGC Level (Not Latched).
<1>	Latched Alarm 2	Bit 0 = Buffer underflow. 1 = Fail Bit 1 = Buffer overflow. 1 = Fail Bit 2 = Buffer under 10%. 1 = Fail Bit 3 = Buffer over 90%. 1 = Fail Bit 4 = RS Decoder Lock Fault. 1 = Fail Bit 5 = RS De-Interleaver Fault. 1 = Fail Bit 6 = RS Decoder Uncorrectable Word. 1 = Fail Bit 7 = Summary Fault. 1 = Fail
<1>	Latched Alarm 3	Bit 0 = IF synthesizer lock detect Fault. 1 = Fail Bit 1 = Rx Oversample PLL lock detect. 1 = Fail Bit 2 = Buffer clock PLL lock detect. 1 = Fail Bit 3 = Viterbi decoder lock (Not Latched) Bit 4 = Sequential decoder lock (Not Latched) Bit 5 = Rx 2047 test pattern lock (Not Latched) Bit 6 = External reference PLL lock (Not Latched) Bit 7 = IDR 96 PLL Lock. 1 = Fail
<1>	Latched Common Alarm 1	Bit 0 = -12V alarm. 1 = Fail Bit 1 = +12V alarm. 1 = Fail Bit 2 = +5V alarm. 1 = Fail Bit 3 = Reserved

		Bit 4 = Battery. 1 = Fail Bit 5 = RAM and ROM alarm flag. 1 = Fail Bits 6 and 7 = Spares
<1>	Latched Common Alarm 2	Bit 0 = M&C processor fault 1 = Fail Bit 1 = U IO card present alarm 1 = Fail, reserved in RCS10/10L mode Bit 2 = IF card present alarm 1 = Fail Bits 3 - 7 = Spares
<1>	Backward Alarm	Bit 0 = Backward Alarm 1 IDR and IBS Bit 1 = Backward Alarm 2 IDR only Bit 2 = Backward Alarm 3 IDR only Bit 3 = Backward Alarm 4 IDR only Bits 4 - 7 = Reserved 0 = No, 1 = Yes
<4>	Error Counter	Binary value
<4>	Test 2047 Error Counter	Binary value
<2>	Raw BER Mantissa	Bytes 1 - 2 = Binary value Raw BER 896 = 8.96
<2>	Corrected BER Mantissa	Bytes 1 - 2 = Binary value corrected BER
<2>	EbNo	Binary value, 1 decimal point implied 700 = 7.00
<4>	Offset Frequency	Binary value, 1 Hz steps
<2>	Test 2047 BER Mantissa	Bytes 1 - 2 = Binary value test 2047 BER
<1>	Raw BER Exponent	Byte 3 = Binary value exponent
<1>	Corrected BER Exponent	Byte 3 = Binary value exponent
<1>	Test 2047 BER Exponent	Byte 3 = Binary value exponent
<1>	Offset Frequency Sign	If <> 0, '-' offset
<1>	BER/EbNo Status	Bit 0 = Raw BER and corrected BER status. 1 = Valid Bit 1 = Test 2047 BER status. 1 = Valid Bits 2 - 3 = EbNo status, 0 = EbNo is invalid, 1 = EbNo is valid, 2 = EbNo is smaller than indicated, value, 3 = EbNo is greater than indicated value Bit 4 = BER Counter Overflow. 1 = Overflow Condition Bit 5 = Test 2047 BER Counter Overflow 1 = Overflow Condition Bits 6 - 7 = Reserved
<1>	Buffer Percent Full	Binary value representing % buffer full, 0 - 100 in 1% steps
<1>	Input Level	Binary value in 1 dB steps

<1>	Insert Status Fault	Bit 0 = Frame lock fault. 1 = Fail Bit 1 = Multiframe lock fault. Valid in E1 PCM30 and PCM30C. 1 = Fail Bit 2 = CRC lock fault. Valid in T1ESF, and E1 CRC enabled. 1 = Fail Bit 3 = T1 yellow alarm received. 1 = Received Bit 4 = E1 FAS alarm received. 1 = Received Bit 5 = E1 MFAS alarm received. Not valid in FAS mode. 1 = Received Bit 6 = E1 CRC alarm received. 1 = Received Bit 7 = CRC calculation error. 1 = Fail
<1>	Online Flag	0 = Offline, 1 = Online
<1>	Loss Flag	1 = Loss of IDI Signal, DMD15
<1>	Alarm 5	Bit 0 = Trellis Decoder Lock. 1 = Lock Bit 1 = FM DSP Lock. 1 = Lock Bit 2 = T1 signaling fault. 1 = Fail Bit 3 = Turbo Codec Lock Fault. 1 = Fail Bits 4 – 7 = Spares
<1>	Latched Alarm 4	Bit 0 = Buffer clock activity detect. (Not Latched) Bit 1 = External BNC activity detect. (Not Latched), reserved in RCS10/10L mode Bit 2 = Rx satellite clock activity detect. 1 = Fail Bit 3 = Insert clock activity detect. 1 = Fail Bit 4 = External reference PLL activity. (Not Latched), reserved in RCS10/10L mode Bit 5 = High Stability reference PLL activity. (Not Latched), reserved in RCS10/10L mode Bit 6 = Rx clock fallback. (Not Latched) Bit 7 = Eb/No Threshold Fault. (Not Latched)
<4>	Symbol Rate	Binary value, 1 sps steps
<77>	Reserved	Reserved

Opcode: <240Ch> Query a Demodulator's Status

Query Response		
<1>	Control Mode	0 = Front Panel. 1 = Terminal, 2 = Computer
<1>	Revision Number	Decimal point implied
<1>	Alarm 1	Bit 0 = Receive processor fault. 1 = Fail Bit 1 = Carrier Loss. 0 = pass. 1 = Fail Bit 2 = Multiframe Sync Loss 0 = pass. 1 = Fail Bit 3 = Frame Sync Loss 0 = pass. 1 = Fail Bit 4 = IBS BER Alarm 0 = pass. 1 = Fail Bit 5 = Satellite AIS 0 = pass. 1 = Fail Bit 6 = Rx Data Activity. 1 = Activity Bit 7 = RX AGC Level. 0 = Pass, 1 = Fail
<1>	Alarm 2	Bit 0 = Buffer underflow. 0 = OK. 1 = Underflow Bit 1 = Buffer overflow. 0 = OK. 1 = Overflow Bit 2 = Buffer under 10%. 1 = Under 10% Bit 3 = Buffer over 90%. 1 = Over 90%

		Bit 4 = RS Decoder Lock Fault. 1 = Fail Bit 5 = RS De-Interleaver Fault. 1 = Fail Bit 6 = RS Decoder Uncorrectable Word. 1 = Fail Bit 7 = Summary Fault. 1 = Fail
<1>	Alarm 3	Bit 0 = IF synthesizer lock detect. 1 = Lock Bit 1 = Rx Oversample PLL lock detect. 1 = Lock Bit 2 = Buffer clock PLL lock detect. 1 = Lock Bit 3 = Viterbi decoder lock. 1 = Lock Bit 4 = Sequential decoder lock. 1 = Lock Bit 5 = Rx 2047 test pattern lock. 1 = Lock Bit 6 = External reference PLL lock. 1 = Lock Bit 7 = IDR 96K PLL Lock. 1 = Lock
<1>	Alarm 4	Bit 0 = Buffer clock activity detect. 1 = Activity Bit 1 = External BNC activity detect. 1 = Activity, reserved in RCS10/10L mode Bit 2 = Rx satellite clock activity detect. 1 = Activity Bit 3 = Insert clock activity detect. 1 = Activity Bit 4 = External reference PLL activity. 1 = Activity, reserved in RCS10/10L mode Bit 5 = High Stability reference PLL activity. 1 = Activity, reserved in RCS10/10L mode Bit 6 = Rx clock fallback. 1 = Fail Bit 7 = Eb/No Threshold, 1 = Fail
<1>	Common Alarm 1	Bit 0 = -12V alarm. 1 = Fail Bit 1 = +12V alarm. 1 = Fail Bit 2 = +5V alarm. 1 = Fail Bit 3 = Reserved Bit 4 = Battery. 1 = Fail Bit 5 = RAM and ROM alarm flag. 1 = Fail Bits 6 and 7 = Spares
<1>	Common Alarm 2	Bit 0 = M&C processor fault. 1 = Fail Bit 1 = U IO card present. 1 = Present, reserved in RCS10/10L mode Bit 2 = IF card present. 1 = Present Bits 3 - 7 = Spares
<1>	Latched Alarm 1	Bit 0 = Receive processor fault Alarm. 1 = Fail Bit 1 = Carrier Loss 1 = Fail Bit 2 = Multiframe Sync Loss 1 = Fail Bit 3 = Frame Sync Loss 1 = Fail Bit 4 = IBS BER Alarm 1 = Fail Bit 5 = Satellite AIS 1 = Fail Bit 6 = Rx Data Activity. 1 = Fail Bit 7 = Rx AGC Level (Not Latched).
<1>	Latched Alarm 2	Bit 0 = Buffer underflow. 1 = Fail Bit 1 = Buffer overflow. 1 = Fail Bit 2 = Buffer under 10%. 1 = Fail Bit 3 = Buffer over 90%. 1 = Fail

		Bit 4 = RS Decoder Lock Fault. 1 = Fail Bit 5 = RS De-Interleaver Fault. 1 = Fail Bit 6 = RS Decoder Uncorrectable Word. 1 = Fail Bit 7 = Summary Fault. 1 = Fail
<1>	Latched Alarm 3	Bit 0 = IF synthesizer lock detect Fault. 1 = Fail Bit 1 = Rx Oversample PLL lock detect. 1 = Fail Bit 2 = Buffer clock PLL lock detect. 1 = Fail Bit 3 = Viterbi decoder lock (Not Latched) Bit 4 = Sequential decoder lock (Not Latched) Bit 5 = Rx 2047 test pattern lock (Not Latched) Bit 6 = External reference PLL lock (Not Latched) Bit 7 = IDR 96 PLL Lock. 1 = Fail
<1>	Latched Common Alarm 1	Bit 0 = -12V alarm. 1 = Fail Bit 1 = +12V alarm. 1 = Fail Bit 2 = +5V alarm. 1 = Fail Bit 3 = Reserved Bit 4 = Battery. 1 = Fail Bit 5 = RAM and ROM alarm flag. 1 = Fail Bits 6 and 7 = Spares
<1>	Latched Common Alarm 2	Bit 0 = M&C processor fault 1 = Fail Bit 1 = U IO card present alarm 1 = Fail, reserved in RCS10/10L mode Bit 2 = IF card present alarm 1 = Fail Bits 3 - 7 = Spares
<1>	Backward Alarm	Bit 0 = Backward Alarm 1 IDR and IBS Bit 1 = Backward Alarm 2 IDR only Bit 2 = Backward Alarm 3 IDR only Bit 3 = Backward Alarm 4 IDR only Bits 4 - 7 = Reserved 0 = No, 1 = Yes
<4>	Error Counter	Binary value
<4>	Test 2047 Error Counter	Binary value
<2>	Raw BER Mantissa	Bytes 1 - 2 = Binary value Raw BER 896 = 8.96
<2>	Corrected BER Mantissa	Bytes 1 - 2 = Binary value corrected BER
<2>	EbNo	Binary value, 1 decimal point implied 700 = 7.00
<4>	Offset Frequency	Binary value, 1 Hz steps
<2>	Test 2047 BER Mantissa	Bytes 1 - 2 = Binary value test 2047 BER
<1>	Raw BER Exponent	Byte 3 = Binary value exponent
<1>	Corrected BER Exponent	Byte 3 = Binary value exponent
<1>	Test 2047 BER	Byte 3 = Binary value exponent

	Exponent	
<1>	Offset Frequency Sign	If <> 0, '-' offset
<1>	BER/EbNo Status	Bit 0 = Raw BER and corrected BER status. 1 = Valid Bit 1 = Test 2047 BER status. 1 = Valid Bits 2 - 3 = EbNo status, 0 = EbNo is invalid, 1 = EbNo is valid, 2 = EbNo is smaller than indicated, value, 3 = EbNo is greater than indicated value Bit 4 = BER Counter Overflow. 1 = Overflow Condition Bit 5 = Test 2047 BER Counter Overflow 1 = Overflow Condition Bits 6 - 7 = Reserved
<1>	Buffer Percent Full	Binary value representing % buffer full, 0 - 100 in 1% steps
<1>	Input Level	Binary value in 1 dB steps
<1>	Insert Status Fault	Bit 0 = Frame lock fault. 1 = Fail Bit 1 = Multiframe lock fault. Valid in E1 PCM30 and PCM30C. 1 = Fail Bit 2 = CRC lock fault. Valid in T1ESF, and E1 CRC enabled. 1 = Fail Bit 3 = T1 yellow alarm received. 1 = Received Bit 4 = E1 FAS alarm received. 1 = Received Bit 5 = E1 MFAS alarm received. Not valid in FAS mode. 1 = Received Bit 6 = E1 CRC alarm received. 1 = Received Bit 7 = CRC calculation error. 1 = Fail
<1>	Online Flag	0 = Offline, 1 = Online
<1>	Loss Flag	1 = Loss of IDI Signal, DMD15
<1>	Alarm 5	Bit 0 = Trellis Decoder Lock. 1 = Lock Bit 1 = FM DSP Lock. 1 = Lock Bit 2 = T1 signaling fault. 1 = Fail Bit 3 = Turbo Codec Lock Fault. 1 = Fail Bits 4 - 7 = Spares
<1>	Latched Alarm 4	Bit 0 = Buffer clock activity detect. (Not Latched) Bit 1 = External BNC activity detect. (Not Latched), reserved in RCS10/10L mode Bit 2 = Rx satellite clock activity detect. 1 = Fail Bit 3 = Insert clock activity detect. 1 = Fail Bit 4 = External reference PLL activity. (Not Latched), reserved in RCS10/10L mode Bit 5 = High Stability reference PLL activity. (Not Latched),

		reserved in RCS10/10L mode Bit 6 = Rx clock fallback. (Not Latched) Bit 7 = Eb/No Threshold Fault. (Not Latched)
<4>	Symbol Rate	Binary value, 1 sps steps
<77>	Reserved	Reserved

Opcode: <2406h> Query a demodulator's latched alarms

Query Response		
<1>	Latched Alarm 1	Bit 0 = Receive processor fault Alarm. 1 = Fail Bit 1 = Carrier Loss 1 = Fail Bit 2 = Multiframe Sync Loss 1 = Fail Bit 3 = Frame Sync Loss 1 = Fail Bit 4 = IBS BER Alarm 1 = Fail Bit 5 = Satellite AIS 1 = Fail Bit 6 = Rx Data Activity. 1 = Fail Bit 7 = Rx AGC Level (Not Latched).
<1>	Latched Alarm 2	Bit 0 = Buffer underflow. 1 = Fail Bit 1 = Buffer overflow. 1 = Fail Bit 2 = Buffer under 10%. 1 = Fail Bit 3 = Buffer over 90%. 1 = Fail Bit 4 = RS Decoder Lock Fault. 1 = Fail Bit 5 = RS De-Interleaver Fault. 1 = Fail Bit 6 = RS Decoder Uncorrectable Word. 1 = Fail Bit 7 = Summary Fault. 1 = Fail
<1>	Latched Alarm 3	Bit 0 = IF synthesizer lock detect Fault. 1 = Fail Bit 1 = Rx Oversample PLL lock detect. 1 = Fail Bit 2 = Buffer clock PLL lock detect. 1 = Fail Bit 3 = Viterbi decoder lock (Not Latched) Bit 4 = Sequential decoder lock (Not Latched) Bit 5 = Rx 2047 test pattern lock (Not Latched) Bit 6 = External reference PLL lock (Not Latched) Bit 7 = IDR 96 PLL Lock. 1 = Fail
<1>	Latched Common Alarm 1	Bit 0 = -12V alarm. 1 = Fail Bit 1 = +12V alarm. 1 = Fail Bit 2 = +5V alarm. 1 = Fail Bit 3 = Reserved Bit 4 = Battery. 1 = Fail Bit 5 = RAM and ROM alarm flag. 1 = Fail Bits 6 and 7 = Spares
<1>	Latched Common Alarm 2	Bit 0 = M&C processor fault 1 = Fail Bit 1 = U IO card present alarm 1 = Fail, reserved in RCS10/10L mode Bit 2 = IF card present alarm 1 = Fail Bits 3 - 7 = Spares
<1>	Latched Alarm 4	Bit 0 = Buffer clock activity detect. (Not Latched) Bit 1 = External BNC activity detect. (Not Latched), reserved in RCS10/10L mode Bit 2 = Rx satellite clock activity detect. 1 = Fail Bit 3 = Insert clock activity detect. 1 = Fail Bit 4 = External reference PLL activity. (Not Latched), reserved

		in RCS10/10L mode Bit 5 = High Stability reference PLL activity. (Not Latched), reserved in RCS10/10L mode Bit 6 = Rx clock fallback. (Not Latched) Bit 7 = Eb/No Threshold Fault. (Not Latched)
--	--	---

Opcode: <2409h> Query a demodulator's current alarms

Query Response		
<1>	Alarm 1	Bit 0 = Receive processor fault. 1 = Fail Bit 1 = Carrier Loss. 0 = pass. 1 = Fail Bit 2 = Multiframe Sync Loss 0 = pass. 1 = Fail Bit 3 = Frame Sync Loss 0 = pass. 1 = Fail Bit 4 = IBS BER Alarm 0 = pass. 1 = Fail Bit 5 = Satellite AIS 0 = pass. 1 = Fail Bit 6 = Rx Data Activity. 1 = Activity Bit 7 = RX AGC Level. 0 = Pass, 1 = Fail
<1>	Alarm 2	Bit 0 = Buffer underflow. 0 = OK. 1 = Underflow Bit 1 = Buffer overflow. 0 = OK. 1 = Overflow Bit 2 = Buffer under 10%. 1 = Under 10% Bit 3 = Buffer over 90%. 1 = Over 90% Bit 4 = RS Decoder Lock Fault. 1 = Fail Bit 5 = RS De-Interleaver Fault. 1 = Fail Bit 6 = RS Decoder Uncorrectable Word. 1 = Fail Bit 7 = Summary Fault. 1 = Fail
<1>	Alarm 3	Bit 0 = IF synthesizer lock detect. 1 = Lock Bit 1 = Rx Oversample PLL lock detect. 1 = Lock Bit 2 = Buffer clock PLL lock detect. 1 = Lock Bit 3 = Viterbi decoder lock. 1 = Lock Bit 4 = Sequential decoder lock. 1 = Lock Bit 5 = Rx 2047 test pattern lock. 1 = Lock Bit 6 = External reference PLL lock. 1 = Lock Bit 7 = IDR 96K PLL Lock. 1 = Lock
<1>	Alarm 4	Bit 0 = Buffer clock activity detect. 1 = Activity Bit 1 = External BNC activity detect. 1 = Activity, reserved in RCS10/10L mode Bit 2 = Rx satellite clock activity detect. 1 = Activity Bit 3 = Insert clock activity detect. 1 = Activity Bit 4 = External reference PLL activity. 1 = Activity, reserved in RCS10/10L mode Bit 5 = High Stability reference PLL activity. 1 = Activity, reserved in RCS10/10L mode Bit 6 = Rx clock fallback. 1 = Fail Bit 7 = Eb/No Threshold, 1 = Fail
<1>	Insert Status Fault	Bit 0 = Frame lock fault. 1 = Fail Bit 1 = Multiframe lock fault. Valid in E1 PCM30 and PCM30C. 1 = Fail Bit 2 = CRC lock fault. Valid in T1ESF, and E1 CRC enabled. 1 = Fail Bit 3 = T1 yellow alarm received. 1 = Received

<1>	Common Alarm 1	<p>Bit 4 = E1 FAS alarm received. 1 = Received Bit 5 = E1 MFAS alarm received. Not valid in FAS mode. 1 = Received Bit 6 = E1 CRC alarm received. 1 = Received Bit 7 = CRC calculation error. 1 = Fail</p> <p>Bit 0 = -12V alarm. 1 = Fail Bit 1 = +12V alarm. 1 = Fail Bit 2 = +5V alarm. 1 = Fail Bit 3 = Reserved Bit 4 = Battery. 1 = Fail Bit 5 = RAM and ROM alarm flag. 1 = Fail Bits 6 and 7 = Spares</p>
<1>	Common Alarm 2	<p>Bit 0 = M&C processor fault. 1 = Fail Bit 1 = U IO card present. 1 = Present, reserved in RCS10/10L mode Bit 2 = IF card present. 1 = Present Bits 3 - 7 = Spares</p>

Opcode: <2A00h> Command a demodulator's configuration

<1>	Mode	0 = Closed Net. 1 = IDR, 2 = IBS, 3 = D&I
<4>	Frequency	Selects the IF frequency in Hz. The range is 50 MHz to 180 MHz for the 70/140 MHz type modems and 950 MHz to 1750 MHz for the L-Band Modems. Unsigned 0.0 – 900.0
<2>	Sweep Delay	Binary value, 0.1 second steps 0.1 – 299.9
<4>	Data Rate	Binary value, 1 bps steps
<1>	Sweep Boundary	Sweep limits. Max of ± 32 kHz in kHz steps 1 - 32
<1>	Input Level Limit	Lower level limit, binary value, 1 dB steps. Reserved
<2>	Strap Code	Binary value
<1>	Filter Mask	0 = INTELSAT, 1 = EUTELSAT, 2 = CLOSED NET1
<1>	Demodulation Type	0 = QPSK, 1 = BPSK, 2 = 8PSK, 3 = 16QAM, 4 = OQPSK
<1>	Convolutional Decoder	0 = None, 1 = Viterbi 1/2 Rate, 2 = Viterbi 2/3 Rate, 3 = Viterbi 3/4 Rate, 4 = Viterbi 5/6 Rate, 5 = Viterbi 7/8 Rate, 6 = Viterbi 8/9 Rate, 7 = Sequential 1/2 Rate, 8 = Sequential 2/3 Rate, 9 = Sequential 3/4 Rate, 10 = Sequential 5/6 Rate, 11 = Sequential 7/8 Rate, 12 = Sequential 8/9 Rate, 13 = Trellis 1/2 Rate, 14 = Trellis 2/3 Rate, 15 = Trellis 3/4 Rate, 16 = Trellis 5/6 Rate, 17 = Trellis 7/8 Rate, 18 = Trellis 8/9 Rate, 19 = SEQ 3/4 Rate, 20 = TPC .793 2D, 21 = TPC .495 3D, 22 = TPC .325 3D
<1>	Reed Solomon	0 = Disable, 1 = Enable
<1>	Differential Decoder	0 = Off, 1 = On, 2 = EF Mode* *Available in uncoded QPSK modulation for compatibility.
<1>	Descrambler Control	0 = Disable, 1 = Enable

<1>	Descrambler Type	0 = None, 1 = IBS Scrm., 2 = V35_IESS, 3 = V35_CCITT, 4 = V35_EFDATA, 5 = V35_FAIRCHILD, 6 = OM73, 7 = RS Descrambler, 8 = V.35 EF RS Descrambler, 9 = TPC Scrambler
<1>	Spectrum	0 = Normal, 1 = Inverted
<1>	Buffer Size Msec	Indicates buffer size in msec. 0 through 32
<1>	Buffer Clock	0 = SCTE, 1 = SCT, 2 = EXT EXC, 3 = RX SAT
<1>	Buffer Clock Polarity	0 = Normal, 1 = Inverted
<1>	Insert Mode	0 = Disabled, 1 = T1-D4, 2 = T1-ESF, 3 = PCM-30, 4 = PCM-30C, 5 = PCM-31, 6 = PCM-31C, 7 = SLC-96, 8 = T1 D4 S, 9 = T1 ESF S
<1>	T1E1 Frame Source	0 = Internal, 1 = External
<30>	Insert Map	Timeslots to insert organized by satellite channel
<1>	Framing	0 = No framing, 1 = 96K, 2 = 1/15, 3 = EF AUPC 1/15
<1>	Operating Mode	0 = Stop, 1 = 2047 test
<1>	Map Summary To Backward Alarm	0 = None, 1 = BK1, 2 = BK2, 3 = BK1 & 2, 4 = BK3, 5 = BK1 & 3, 6 = BK2 & 3, 7 = BK1, 2 & 3, 8 = BK4, 9 = BK1 & 4, 10 = BK2 & 4, 11 = BK1, 2 & 4, 12 = BK3 & 4, 13 = BK1, 3 & 4, 14 = BK2, 3 & 4, 15 = BK1, 2, 3 & 4
<1>	Forced Alarms	0 = None, 1 = Send the Alarm Bits 0 – 7 = Spares
<1>	Alarm 1 Mask	Bit 0 = Rx proc Bit 1 = Carrier Loss Bit 2 = Multiframe Sync Loss Bit 3 = Frame Sync Loss Bit 4 = IBS BER Alarm Bit 5 = Satellite AIS Bit 6 = Rx Data Activity Bit 7 = Rx AGC Level 0 = Mask, 1 = Allow
<1>	Alarm 2 Mask	Bit 0 = Buffer underflow Bit 1 = Buffer overflow Bit 2 = Buffer under 10% Bit 3 = Buffer over 90% Bit 4 = RS Decoder Lock Fault Bit 5 = RS De-Interleaver Fault Bit 6 = RS Decoder Uncorrectable Word Bit 7 = Summary Fault 0 = Mask, 1 = Allow
<1>	Alarm 3 Mask	Bit 0 = IF synthesizer lock detect

<1>	Alarm 4 Mask	<p>Bit 1 = Rx Oversample PLL lock detect Bit 2 = Buffer clock PLL lock detect Bit 3 = Viterbi decoder lock Bit 4 = Sequential decoder lock Bit 5 = Rx 2047 test pattern lock Bit 6 = External reference PLL lock Bit 7 = IDR 96K PLL Lock 0 = Mask, 1 = Allow</p> <p>Bit 0 = Buffer clock activity detect Bit 1 = External BNC activity detect, reserved in RCS10/10L mode Bit 2 = Rx satellite clock activity detect Bit 3 = Insert clock activity detect Bit 4 = External reference PLL activity, reserved in RCS10/10L mode Bit 5 = High Stability reference PLL activity, reserved in RCS10/10L mode Bit 6 = Rx clock fallback Bit 7 = Eb/No Threshold 0 = Mask, 1 = Allow</p>
<1>	Common Alarm 1 Mask	<p>Bit 0 = -12V alarm Bit 1 = +12V alarm Bit 2 = +5V alarm Bit 3 = Reserved Bit 4 = Battery Bit 5 = RAM and ROM alarm flag Bits 6 and 7 = Spares 0 = Mask, 1 = Allow</p>
<1>	Common Alarm 2 Mask	<p>Bit 0 = M&C processor fault Bit 1 = U IO card present, reserved in RCS10/10L mode Bit 2 = IF card present Bits 3 - 7 = Spares 0 = Mask, 1 = Allow</p>
<1>	ESC Channel 1 Volume	Binary value, valid in IDR only, +10 dBm to -20 dBm (two's compliment)
<1>	ESC Channel 2 Volume	Binary value, valid in IDR only, +10 dBm to -20 dBm (two's compliment)
<1>	BER Exponent	6 through 9 for Viterbi, 5 through 7 for Sequential
<11>	Rx Circuit ID	11 ASCII characters
<1>	Rx Terrestrial Loopback	0 = Disabled, 1 = Enabled
<1>	Rx Baseband Loopback	0 = Disabled, 1 = Enabled
<1>	Rx IF Loopback	0 = Disabled, 1 = Enabled
<1>	Rx Interface Type	0 = G703-B-T1-AMI, 1 = G703-B-T1_B8ZS, 2 = G703-B-E1, 3 = G703-B-T2, 4 = G703-U-E1, 5 = G703-U-T2, 6 = G703-U-E2,

<1>	Insert Status Mask	7 = RS-422, 8 = V.35, 9 = RS-232 Bit 0 = Frame lock Bit 1 = Multiframe lock. Valid in E1 PCM30 and PCM30C Bit 2 = CRC lock. Valid in T1ESF, and E1 CRC enabled Bit 3 = T1 yellow alarm received Bit 4 = E1 FAS alarm received Bit 5 = E1 MFAS alarm received. Not valid in FAS mode Bit 6 = E1 CRC alarm received Bit 7 = CRC calculation error 0 = Mask, 1 = Allow
<1>	Rx Reed Solomon N Code	2 - 255 Reed-Solomon code word length
<1>	Rx Reed Solomon K Code	1 - 254 Reed-Solomon message length
<1>	Rx Reed Solomon Depth	4 or 8
<1>	External Clock Source	0 = BNC EXC, 1 = Balanced EXC, 2 = IDI, 3 = SYS [RCS10 Only]
<1>	Data Invert	0 = None, 1 = Terrestrial, 2 = Baseband 3 = Terrestrial and Baseband
<1>	Alarm 5 Masks	Bit 0 = Trellis Decoder Lock Bit 1 = FM DSP Lock Mask Bit 2 = T1 signaling fault Bit 3 = Turbo Codec Lock Fault Bits 4 - 7 = Spares 0 = Mask, 1 = Allow
<1>	BPSK Symbol Pairing	0 = Normal, 1 = Swapped
<1>	ES Mode	0 = Normal, 1 = Enhanced
<1>	ES Type	0 = RS-232, 1 = RS-485
<1>	ES Baud	0 = 150. 1 = 300, 2 = 600, 3 = 1200, 4 = 2400, 5 = 4800, 6 = 9600
<1>	ES Data Bits	0 = 7 Bits. 1 = 8 Bits
<1>	IDR Overhead Type	0 = 32K Voice. 1 = 64K Data
<1>	FM Orderwire Mode	0 = Disable, 1 = Enable, 2 = FM Only
<1>	Time Mark Transfer Pattern Length	Unsigned Binary (4 to 16) Inclusively
<1>	Eb/No Threshold	<i>Unsigned Binary Value, 0-99, Implied Decimal Point</i> 0.0 through 9.9 dB
<2>	Reacquisition Sweep Boundary	Unsigned binary value Sweep limits. Max of +/- 32000 Hz in 1 Hz steps 0 – 32000
<37>	Reserved	Reserved

<1>	TPC Deinterleaver	0=Disable, 1=Enable
-----	-------------------	---------------------

Opcode: <2A01h> Command a demodulator's frequency

<4>	Frequency	Selects the IF frequency in Hz. The range is 50 MHz to 180 MHz for the 70/140 MHz type modems and 950 MHz to 1750 MHz for the L-Band Modems.
-----	-----------	--

Opcode: <2A02h> Command a demodulator's data rate

<4>	Data Rate	Binary value, 1 bps steps
-----	-----------	---------------------------

Opcode: <2A03h> Command a demodulator's strap code

<2>	Strap Code	Binary value
-----	------------	--------------

Opcode: <2A04h> Command a demodulator's sweep boundary

<1>	Sweep Boundary	Sweep limits. Max of 32 kHz in kHz steps 1 - 32
-----	----------------	---

Opcode: <2A05h> Command a demodulator's sweep delay

<2>	Sweep Delay	Binary value decimal implied, 0.1 second steps 0.1 – 900.0
-----	-------------	--

Opcode: <2A07h> Command a demodulator's demodulation type

<1>	Demodulation Type	0 = QPSK, 1 = BPSK, 2 = 8PSK, 3 = 16QAM, 4 = OQPSK
-----	-------------------	--

Opcode: <2A08h> Command a demodulator's convolutional decoder

<1>	Convolutional Decoder	0 = None, 1 = Viterbi 1/2 Rate, 2 = Viterbi 2/3 Rate, 3 = Viterbi 3/4 Rate, 4 = Viterbi 5/6 Rate, 5 = Viterbi 7/8 Rate, 6 = Viterbi 8/9 Rate, 7 = Sequential 1/2 Rate, 8 = Sequential 2/3 Rate, 9 = Sequential 3/4 Rate, 10 = Sequential 5/6 Rate, 11 = Sequential 7/8 Rate, 12 = Sequential 8/9 Rate, 13 = Trellis 1/2 Rate, 14 = Trellis 2/3 Rate, 15 = Trellis 3/4 Rate, 16 = Trellis 5/6 Rate, 17 = Trellis 7/8 Rate, 18 = Trellis 8/9 Rate, 19 = SEQ 3/4 Rate, 20 = TPC .793 2D, 21 = TPC .495 3D, 22 = TPC .325 3D
-----	-----------------------	--

Opcode: <2A09h> Command a demodulator's differential decoder

<1>	Differential Decoder	0 = Off, 1 = On, 2 = EF Mode* *Available in uncoded QPSK modulation for compatibility.
-----	----------------------	---

Opcode: <2A0Ah> Command a demodulator's Reed Solomon

<1>	Reed Solomon	0 = Disable, 1 = Enable
-----	--------------	-------------------------

Opcode: <2A0Bh> Command a demodulator's mode

<1>	Mode	0 = Closed Net. 1 = IDR, 2 = IBS, 3 = D&I
-----	------	---

Opcode: <2A0Ch> Command a demodulator's filter mask

<1>	Filter Mask	0 = INTELSAT, 1 = EUTELSAT, 2 = CLOSED NET1
-----	-------------	---

Opcode: <2A0Dh> Command a demodulator's descrambler control

<1>	Descrambler Control	0 = Disable, 1 = Enable
-----	---------------------	-------------------------

Opcode: <2A0Eh> Command a demodulator's descrambler type

<1>	Descrambler Type	0 = None, 1 = IBS Scrm., 2 = V35_I ESS, 3 = V35_CCITT, 4 = V35_EF DATA, 5 = V35_FAIRCHILD, 6 = OM73, 7 = RS Descrambler, 8 = V.35 EF RS Descrambler, 9 = TPC Scrambler
-----	------------------	--

Opcode: <2A0Fh> Command a demodulator's spectrum

<1>	Spectrum	0 = Normal, 1 = Inverted
-----	----------	--------------------------

Opcode: <2A10h> Command a demodulator's buffer size

<1>	Buffer Size Msec	Indicates buffer size in msec. 0 through 32
-----	------------------	---

Opcode: <2A11h> Command a demodulator's buffer clock

<1>	Buffer Clock	0 = SCTE, 1 = SCT, 2 = EXT EXC, 3 = RX SAT
-----	--------------	--

Opcode: <2A12h> Command a demodulator's buffer clock polarity

<1>	Buffer Clock Polarity	0 = Normal, 1 = Inverted
-----	-----------------------	--------------------------

Opcode: <2A13h> Command a demodulator's insert mode

<1>	Insert Mode	0 = Disabled, 1 = T1-D4, 2 = T1-ESF, 3 = PCM-30, 4 = PCM-30C, 5 = PCM-31, 6 = PCM-31C, 7 = SLC-96, 8 = T1 D4 S, 9 = T1 ESF S
-----	-------------	--

Opcode: <2A15h> Command a demodulator's T1E1 frame source

<1>	T1E1 Frame Source	0 = Internal, 1 = External
-----	-------------------	----------------------------

Opcode: <2A16h> Command a demodulator's framing

<1>	Framing	0 = No framing, 1 = 96K, 2 = 1/15, 3 = EF AUPC 1/15
-----	---------	---

Opcode: <2A17h> Command a demodulator's operating mode

<1>	Operating Mode	0 = Stop, 1 = 2047 test
-----	----------------	-------------------------

Opcode: <2A18h> Command map summary to backward alarm

<1>	Map Summary To Backward Alarm	0 = None, 1 = BK1, 2 = BK2, 3 = BK1 & 2, 4 = BK3, 5 = BK1 & 3, 6 = BK2 & 3, 7 = BK1, 2 & 3, 8 = BK4, 9 = BK1 & 4, 10 = BK2 & 4, 11 = BK1, 2 & 4, 12 = BK3 & 4, 13 = BK1, 3 & 4, 14 = BK2, 3 & 4, 15 = BK1, 2, 3 & 4
-----	-------------------------------	---

Opcode: <2A1Ah> Command a demodulator's BER exponent

<1>	BER Exponent	6 through 9 for Viterbi, 5 through 7 for Sequential
-----	--------------	---

Opcode: <2A1Bh> Command a demodulator's circuit ID

<11>	Rx Circuit ID	11 ASCII characters
------	---------------	---------------------

Opcode: <2A1Ch> Command a demodulator's terrestrial loopback

<1>	Rx Terrestrial Loopback	0 = Disabled, 1 = Enabled
-----	-------------------------	---------------------------

Opcode: <2A1Dh> Command a demodulator's baseband loopback

<1>	Rx Baseband Loopback	0 = Disabled, 1 = Enabled
-----	----------------------	---------------------------

Opcode: <2A1Eh> Command a demodulator's IF loopback

<1>	Rx IF Loopback	0 = Disabled, 1 = Enabled
-----	----------------	---------------------------

Opcode: <2A1Fh> Command a demodulator's interface type

<1>	Rx Interface Type	0 = G703-B-T1-AMI, 1 = G703-B-T1_B8ZS, 2 = G703-B-E1, 3 = G703-B-T2, 4 = G703-U-E1, 5 = G703-U-T2, 6 = G703-U-E2, 7 = RS-422, 8 = V.35, 9 = RS-232
-----	-------------------	--

Opcode: <2A20h> Command center buffer (No Parameters)

Opcode: <2A21h> Command Data Invert

<1>	Data Invert	0 = None, 1 = Terrestrial, 2 = Baseband 3 = Terrestrial and Baseband
-----	-------------	--

Opcode: <2A22h> Command Force Demod Summary Alarms

<1>	Summary Alarm	0 = Do not force. 1 = Force
-----	---------------	-----------------------------

Opcode: <2A23h> Command External EXC Source

<1>	External Clock Source	0 = BNC EXC, 1 = Balanced EXC, 2 = IDI, 3 = SYS [RCS10 Only]
-----	-----------------------	--

Opcode: <2A24h> Clear Latched Alarm 1 (No Data)**Opcode: <2A25h> Clear Latched Alarm 2 (No Data)****Opcode: <2A26h> Clear Latched Alarm 3 (No Data)****Opcode: <2A2Eh> Clear Latched Alarm 4 (No Data)****Opcode: <2A2Fh> Command a demodulator's reacquisition sweep.**

<2>	Reacquisition Sweep	Unsigned Binary 0-32000
-----	---------------------	-------------------------

Opcode: <2A32h> Command a demodulator's Reed Solomon N & K Codes & Interleaver Depth

<1>	Rx Reed Solomon N Code	2 - 255 Reed-Solomon code word length
<1>	Rx Reed Solomon K Code	1 - 254 Reed-Solomon message length
<1>	Rx Reed Solomon Depth	4 or 8 Reed Solomon Interleaver Depth

Opcode: <2A33h> Command a demodulator's time mark transfer

<1>	Time Mark Transfer Pattern Length	Unsigned Binary (4 to 16) Inclusively
-----	-----------------------------------	---------------------------------------

4.9.5.3 Modem Queries & Commands**Opcode: <2403h> Query a modem's identification**

Query Response		
<1>	Modem ID	DMD15 Modulator = 20, DMD15 Demodulator = 21, DMD15 Modem = 22

Opcode: <2404h> Query a modem's control mode

Query Response		
<1>	Modem control mode	0 = Front panel. 1 = Terminal, 2 = Computer

Opcode: <2407h> Query a modem's latched alarms

Query Response		
<1>	Mod Latched Alarm 1	Bit 0 = Transmit processor fault. 1 = Fail Bit 1 = Transmit output power level Fault. 1 = Fail Bit 2 = Transmit Oversample PLL lock Fault. 1 = Fail Bit 3 = Composite clock PLL lock Fault. 1 = Fail Bit 4 = IF synthesizer lock Fault. 1 = Fail Bit 5 = IDR 96 PLL Lock Fault. 1 = Fail Bit 6 = RS FIFO Fault. 1 = Fail Bit 7 = Mod Summary Fault. 1 = Fail
<1>	Demod Latched Alarm 1	Bit 0 = Receive processor fault Alarm. 1 = Fail Bit 1 = Carrier Loss 1 = Fail Bit 2 = Multiframe Sync Loss 1 = Fail Bit 3 = Frame Sync Loss 1 = Fail Bit 4 = IBS BER Alarm 1 = Fail Bit 5 = Satellite AIS 1 = Fail Bit 6 = Rx Data Activity. 1 = Fail Bit 7 = Rx AGC Level (Not Latched).
<1>	Demod Latched Alarm 2	Bit 0 = Buffer underflow. 1 = Fail Bit 1 = Buffer overflow. 1 = Fail Bit 2 = Buffer under 10%. 1 = Fail Bit 3 = Buffer over 90%. 1 = Fail Bit 4 = RS Decoder Lock Fault. 1 = Fail Bit 5 = RS De-Interleaver Fault. 1 = Fail Bit 6 = RS Decoder Uncorrectable Word. 1 = Fail Bit 7 = Summary Fault. 1 = Fail
<1>	Demod Latched Alarm 3	Bit 0 = IF synthesizer lock detect Fault. 1 = Fail Bit 1 = Rx Oversample PLL lock detect. 1 = Fail Bit 2 = Buffer clock PLL lock detect. 1 = Fail Bit 3 = Viterbi decoder lock (Not Latched) Bit 4 = Sequential decoder lock (Not Latched) Bit 5 = Rx 2047 test pattern lock (Not Latched) Bit 6 = External reference PLL lock (Not Latched) Bit 7 = IDR 96 PLL Lock. 1 = Fail
<1>	Latched Common Alarm 1	Bit 0 = -12V alarm. 1 = Fail Bit 1 = +12V alarm. 1 = Fail Bit 2 = +5V alarm. 1 = Fail Bit 3 = Reserved Bit 4 = Battery. 1 = Fail Bit 5 = RAM and ROM alarm flag. 1 = Fail Bits 6 and 7 = Spares
<1>	Latched Common Alarm 2	Bit 0 = M&C processor fault. 1 = Fail Bit 1 = U IO card present Fault. 1 = Fail, reserved in RCS10/10L mode Bit 2 = IF card present Fault. 1 = Fail Bits 3 - 7 = Spares
<1>	Demod Latched Alarm 4	Bit 0 = Buffer clock activity detect. (Not Latched) Bit 1 = External BNC activity detect. (Not Latched), reserved in RCS10/10L mode Bit 2 = Rx satellite clock activity detect. 1 = Fail Bit 3 = Insert clock activity detect. 1 = Fail Bit 4 = External reference PLL activity. (Not Latched), reserved

		<p>in RCS10/10L mode Bit 5 = High Stability reference PLL activity. (Not Latched), reserved in RCS10/10L mode Bit 6 = Rx clock fallback. (Not Latched) Bit 7 = Eb/No Threshold Fault. (Not Latched)</p>
<1>	Mod Latched Alarm 2	<p>Bit 0 = Terrestrial clock activity detect. 1 = Fail Bit 1 = Internal clock activity detect. 1 = Fail Bit 2 = Tx Sat clock activity detect. 1 = Fail Bit 3 = Tx data activity detect. 1 = Fail Bit 4 = Tx data AIS detect. 1 = Fail Bit 5 = Tx clock fallback. 1 = Fail Bits 6 & 7 = Spares</p>
<1>	Latched Drop Status	<p>Bit 0 = Frame lock fault. 1 = Fail Bit 1 = Multiframe lock fault. 1 = Fail PCM30 and PCM30C. 1 = Fail Bit 2 = CRC lock fault. Valid in T1 ESF and E1, CRC enabled. 1 = Fail Bits 3-7 (Not latched)</p>

Opcode: <240Ah> Query a modem's current alarms

Query Response		
<1>	Mod Alarm 1	<p>Bit 0 = Transmit processor fault. 1 = Fail Bit 1 = Transmit output power level. 1 = Fail Bit 2 = Transmit Oversample PLL lock. 1 = Lock Bit 3 = Composite clock PLL lock. 1 = Lock Bit 4 = IF synthesizer lock. 1 = Lock Bit 5 = IDR 96 PLL lock. 1 = Lock Bit 6 = RS FIFO fault. 1 = Fail Bit 7 = Mod Summary fault. 1 = Fail</p>
<1>	Mod Alarm 2	<p>Bit 0 = Terrestrial clock activity detect. 1 = Activity Bit 1 = Internal clock activity detect. 1 = Activity Bit 2 = Tx Sat clock activity detect. 1 = Activity Bit 3 = Tx data activity detect. 1 = Activity Bit 4 = Terrestrial AIS. Tx data AIS detect. 1 = AIS Fail Bit 5 = Tx clock fallback. 1 = Fail Bits 6 and 7 = Spares</p>
<1>	Drop Status Fault	<p>Bit 0 = Frame lock fault. 1 = Fail Bit 1 = Multiframe lock Fault. Valid in E1 PCM30 and PCM30C. 1 = Fail Bit 2 = CRC lock fault. Valid in T1ESF, and E1 CRC enabled. 1 = Fail Bit 3 = T1 yellow alarm received. 1 = Received Bit 4 = E1 FAS alarm received. 1 = Received Bit 5 = E1 MFAS alarm received. Not valid in FAS mode. 1 = Received Bit 6 = E1 CRC alarm received. 1 = Received Bit 7 = CRC calculation error. 1 = Fail</p>
<1>	Demod Alarm 1	<p>Bit 0 = Receive processor fault. 1 = Fail Bit 1 = Carrier Loss. 0 = pass. 1 = Fail Bit 2 = Multiframe Sync Loss 0 = pass. 1 = Fail Bit 3 = Frame Sync Loss 0 = pass. 1 = Fail</p>

		<p>Bit 4 = IBS BER Alarm 0 = pass. 1 = Fail Bit 5 = Satellite AIS 0 = pass. 1 = Fail Bit 6 = Rx Data Activity. 1 = Activity Bit 7 = RX AGC Level. 0 = Pass, 1 = Fail</p>
<1>	Demod Alarm 2	<p>Bit 0 = Buffer underflow. 0 = OK. 1 = Underflow Bit 1 = Buffer overflow. 0 = OK. 1 = Overflow Bit 2 = Buffer under 10%. 1 = Under 10% Bit 3 = Buffer over 90%. 1 = Over 90% Bit 4 = RS Decoder Lock Fault. 1 = Fail Bit 5 = RS De-Interleaver Fault. 1 = Fail Bit 6 = RS Decoder Uncorrectable Word. 1 = Fail Bit 7 = Summary Fault. 1 = Fail</p>
<1>	Demod Alarm 3	<p>Bit 0 = IF synthesizer lock detect. 1 = Lock Bit 1 = Rx Oversample PLL lock detect. 1 = Lock Bit 2 = Buffer clock PLL lock detect. 1 = Lock Bit 3 = Viterbi decoder lock. 1 = Lock Bit 4 = Sequential decoder lock. 1 = Lock Bit 5 = Rx 2047 test pattern lock. 1 = Lock Bit 6 = External reference PLL lock. 1 = Lock Bit 7 = IDR 96K PLL Lock. 1 = Lock</p>
<1>	Demod Alarm 4	<p>Bit 0 = Buffer clock activity detect. 1 = Activity Bit 1 = External BNC activity detect. 1 = Activity, reserved in RCS10/10L mode Bit 2 = Rx satellite clock activity detect. 1 = Activity Bit 3 = Insert clock activity detect. 1 = Activity Bit 4 = External reference PLL activity. 1 = Activity, reserved in RCS10/10L mode Bit 5 = High Stability reference PLL activity. 1 = Activity, reserved in RCS10/10L mode Bit 6 = Rx clock fallback. 1 = Fail Bit 7 = Eb/No Threshold, 1 = Fail</p>
<1>	Insert Status Fault	<p>Bit 0 = Frame lock fault. 1 = Fail Bit 1 = Multiframe lock fault. Valid in E1 PCM30 and PCM30C. 1 = Fail Bit 2 = CRC lock fault. Valid in T1ESF, and E1 CRC enabled. 1 = Fail Bit 3 = T1 yellow alarm received. 1 = Received Bit 4 = E1 FAS alarm received. 1 = Received Bit 5 = E1 MFAS alarm received. Not valid in FAS mode. 1 = Received Bit 6 = E1 CRC alarm received. 1 = Received Bit 7 = CRC calculation error. 1 = Fail</p>
<1>	Common Alarm 1	<p>Bit 0 = -12V alarm. 1 = Fail Bit 1 = +12V alarm. 1 = Fail Bit 2 = +5V alarm. 1 = Fail Bit 3 = Reserved Bit 4 = Battery. 1 = Fail Bit 5 = RAM and ROM alarm flag. 1 = Fail Bits 6 and 7 = Spares</p>

<1>	Common Alarm 2	Bit 0 = M&C processor fault. 1 = Fail Bit 1 = U IO card present. 1 = Present, reserved in RCS10/10L mode Bit 2 = IF card present. 1 = Present Bits 3 - 7 = Spares
-----	----------------	--

Opcode: <240Dh> Query a modem's Eb/No, BER, and Level

Query Response		
<2>	Raw BER Mantissa	Bytes 1 - 2 = Binary value Raw BER 896 = 8.96
<2>	Corrected BER Mantissa	Bytes 1 - 2 = Binary value corrected BER
<2>	EbNo	Binary value, 1 decimal point implied 700 = 7.00
<1>	Raw BER Exponent	Byte 3 = Binary value exponent
<1>	Corrected BER Exponent	Byte 3 = Binary value exponent
<1>	BER/EbNo Status	Bit 0 = Raw BER and corrected BER status. 1 = Valid Bit 1 = Test 2047 BER status. 1 = Valid Bits 2 - 3 = EbNo status, 0 = EbNo is invalid, 1 = EbNo is valid, 2 = EbNo is smaller than indicated, value, 3 = EbNo is greater than indicated value Bit 4 = BER Counter Overflow. 1 = Overflow Condition Bit 5 = Test 2047 BER Counter Overflow 1 = Overflow Condition Bits 6 - 7 = Reserved
<1>	Input Level	Binary value in 1 dB steps

Opcode: <240Eh> Query time

Query Response		
<1>	Hour	0 - 23
<1>	Minute	0 - 59
<1>	Second	0 - 59

Opcode: <240Fh> Query date

Query Response		
<1>	Year	0 - 99
<1>	Month	0 - 11
<1>	Day	0 - 30

Opcode: <2410h> Query time and date

Query Response		
<1>	Year	0 - 99
<1>	Month	0 - 11

<1>	Day	0 – 30
<1>	Hour	0 – 23
<1>	Minute	0 – 59
<1>	Second	0 – 59

Opcode: <2411h> Query Modem Summary Faults

Query Response		
<1>	Mod Summary Fault	0 = Pass, 1 = Fail
<1>	Demod Summary Fault	0 = Pass, 1 = Fail

Opcode: <2402h> Query a modem's drop & insert map

<1>	Requested map	0 = Drop active map, 1 = Insert active map, 2 = Drop edit map, 3 = Insert edit map, 4 - 11 = User map #1 through #8, 12 - 19 = ROM maps #1 - #8
Query Response		
<1>	Requested map number	0 = Drop active map, 1 = Insert active map, 2 = Drop edit map, 3 = Insert edit map, 4 - 11 = User map #1 through #8, 12 - 19 = ROM maps #1 - #8
<30>	Requested map	

Opcode: <2C00h> Command drop and insert map copy

<1>	From Map	0 = Drop active map, 1 = Insert active map, 2 = Drop edit map, 3 = Insert edit map, 4 - 11 = User map #1 through #8, 12 - 19 = ROM maps #1 - #8
<1>	To Map	0 = Drop active map, 1 = Insert active map, 2 = Drop edit map, 3 = Insert edit map, 4 - 11 = User map #1 through #8

Opcode: <2C01h> Command drop and insert map

<1>	Map to Change	0 = Drop active map, 1 = Insert active map, 2 = Drop edit map, 3 = Insert edit map, 4 - 11 = User map #1 through #8
<30>	New map	

Opcode: <2C03h> Command clear latched alarms (No Parameters)**Opcode: <2C04h>** Command set time

<1>	Hour	0 – 23
<1>	Minute	0 – 59
<1>	Second	0 – 59

Opcode: <2C05h> Command set date

<1>	Year	0 - 99
<1>	Month	0 - 11

<1>	Day	0 - 30
-----	-----	--------

Opcode: <2C06h> Command set time and date

<1>	Year	0 - 99
<1>	Month	0 - 11
<1>	Day	0 - 30
<1>	Hour	0 - 23
<1>	Minute	0 - 59
<1>	Second	0 - 59

Opcode: <2C08h> Clear Modem Common Latched Alarm 1 (No Data)

Opcode: <2C09h> Clear Modem Common Latched Alarm 2 (No Data)

Opcode: <2C0Bh> Command Modem Terminal Emulation

<1>	Terminal Emulation	0 = Adds Viewpoint. 1 = VT100, 2 = WYSE50
-----	--------------------	---

Opcode: <2C0Ch> Command Modem Baud Rate

<1>	Terminal Baud Rate	0 = 300, 1 = 600, 2 = 1200, 3 = 2400, 4 = 4800, 5 = 9600, 6 = 19200, 7 = 38400, 8 = 150
-----	--------------------	---

Opcode: <2C0Dh> Command Configuration Copy

<1>	From	0 = Current, 1 = Configuration 1, 2 = Configuration 2, 3 = Configuration 3, 4 = Configuration 4, 5 = Configuration 5
<1>	To	0 = Current, 1 = Configuration 1, 2 = Configuration 2, 3 = Configuration 3, 4 = Configuration 4, 5 = Configuration 5

Opcode: <2C0Eh> Command Modem Eb/No Threshold

<1>	Eb/No Threshold	0.0 through 9.9 dB One (1) byte decimal implied
-----	-----------------	---

Opcode: <2D00h> Soft Reset the Modem (No Data)

Section 5 – Electrical Interfaces

5.0 DMD15/DMD15L Connections

All DMD15/DMD15L connections are made to labeled connectors located on the rear of the unit (refer to Figures 5-1 through 5-5). The connector definitions below are those on the DMD15/DMD15L unit. Any connection interfacing to the DMD15/DMD15L must be the appropriate mating connector.

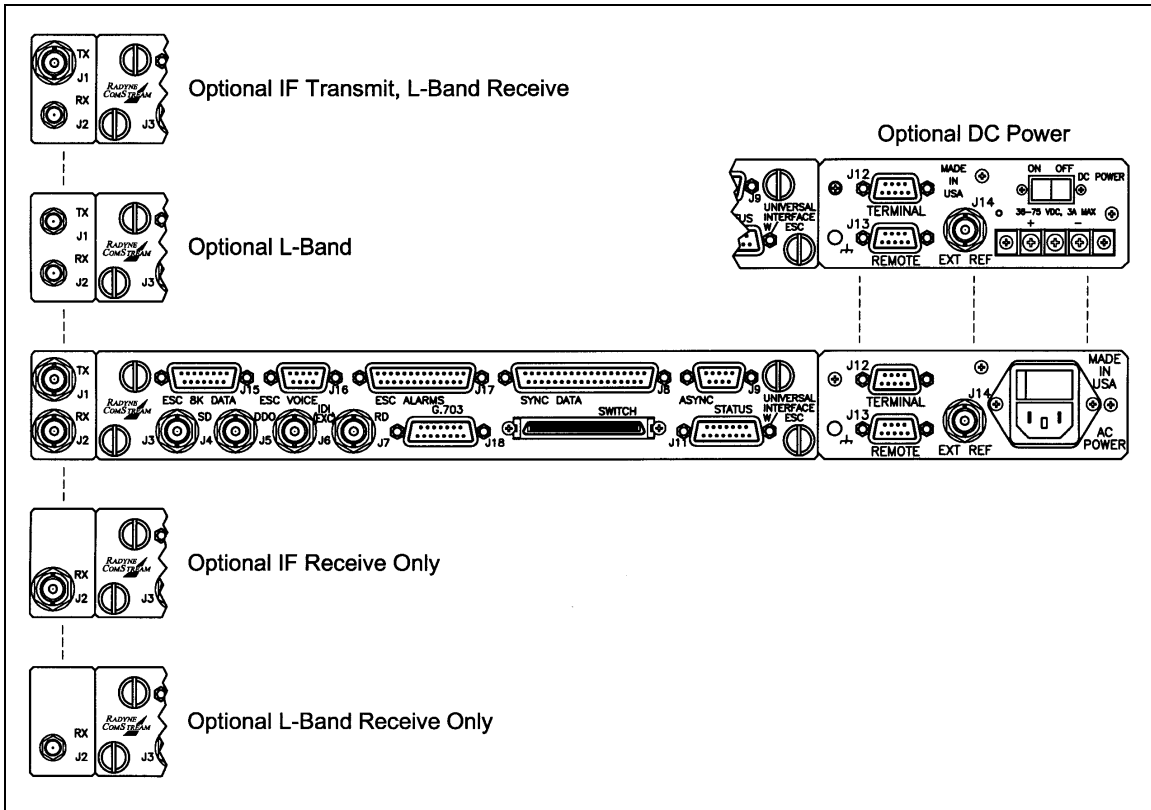

Figure 5-1. DMD15/DMD15L Universal Interface Module w/ESC (shown with available options)

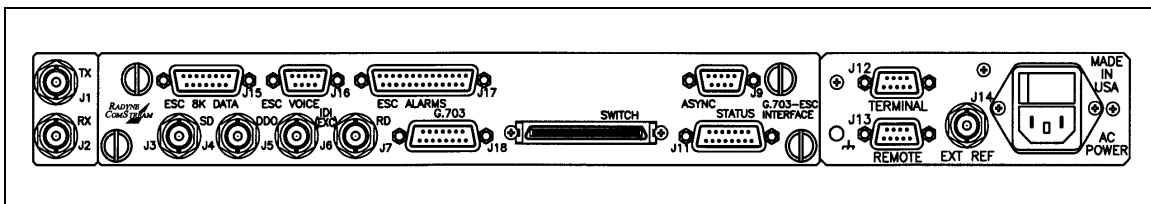

Figure 5-2. DMD15/DMD15L G.703 Interface Module w/ESC

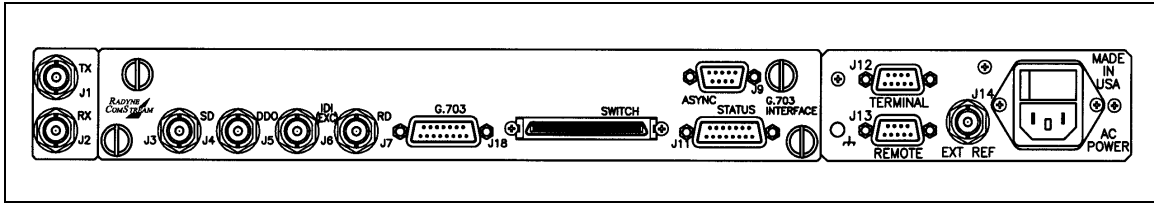

Figure 5-3. DMD15/DMD15L G.703 Interface Module

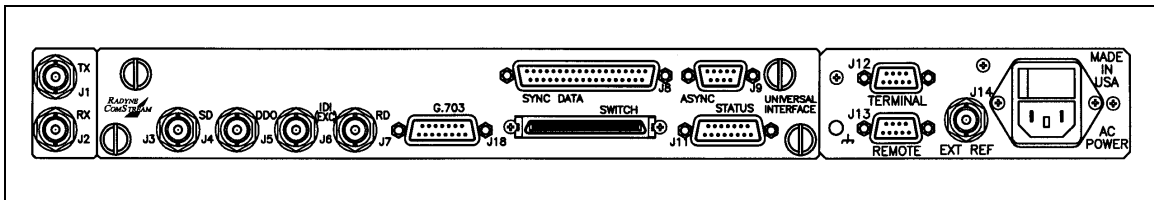

Figure 5-4. DMD15/DMD15L Universal Interface Module

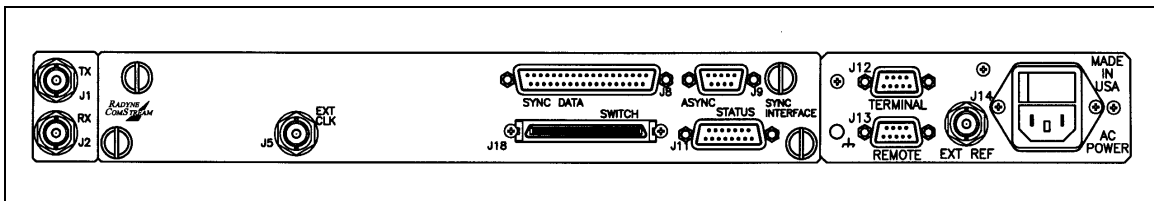

Figure 5-5. DMD15/DMD15L Synchronous Data Interface Module

5.1 Power Inputs

Power Input Modules (Figure 5-1) are located at the right side of the DMD15/DMD15L Unit (as viewed from the rear). There is a 240 VAC, 50 – 60 Hz, and an optional 36 – 75 VDC, 3A (maximum) Power Input Module available. The power cord/connector assembly is a supplied item.

5.1.1 AC Power Input Module

AC Input Module (Figure 5-1) power is applied to the port with the supplied power cable is 10 – 240 VAC, 50 – 60 Hz. Integrated into the Power Input Module is the Power On/Off Rocker Switch. Power consumption for the unit is 1A. A chassis ground connection (size 10-32 thread stud), is located to the lower left of the module.

5.1.2 DC Power Input Module

The Optional DC Power Input Module (Figure 5-1) is available for all DMD15/DMD15L products. The unit may be powered from a 36 – 75 VDC source with a maximum unit power consumption of 3A. The three connections on the power strip are +, Ground, and -. There is also a Power On/Off Rocker Switch. A chassis ground connection (size 10-32 thread stud), is located to the lower left of the module.

5.2 TX (J1)

If the customer orders the 70/140 MHz IF, the Transmit IF Output Port will be a 75-Ohm Female BNC Connector. The power level is programmable from -20 to +5 dBm in 0.1 dBm steps. The IF Frequency can be programmed to 50 – 90 MHz or 100 – 180 MHz, in 1 Hz steps. If an L-Band IF is ordered, the IF Port will be a 50 Ohm SMA Female Connector. The power level is programmable from -30 to -5 dBm, in 0.1 dBm steps. The IF Frequency can be programmed to 950 – 1750 MHz, in 1 Hz steps.

Note: *A receive only option of the DMD15/DMD15L is available. When this option is ordered, there will be no TX Port on the Back Panel.*

5.3 RX (J2)

If the customer orders the 70/140 MHz IF, the Transmit IF Output Port will be a 75-Ohm Female BNC Connector. The power level is programmable from -20 to +5 dBm in 0.1 dBm steps. The IF Frequency can be programmed to 50 – 90 MHz or 100 – 180 MHz, in 1 Hz steps. If an L-Band IF is ordered, the IF Port will be a 50 Ohm SMA Female Connector. The power level is programmable from -30 to -5 dBm, in 0.1 dBm steps. The IF Frequency can be programmed to 950 – 1750 MHz, in 1 Hz steps.

5.4 SD (J3)

The Send Data Port (Unbalanced) is a 75-Ohm Female BNC Connector.

5.5 DDO (J4)

The Drop Data Out Port (Unbalanced) is a 75-Ohm Female BNC Connector.

5.6 IDI EXC (J5)

The Insert Data In Port (Unbalanced) is a 75-Ohm Female BNC Connector.

5.7 EXT CLK (J5) – Synchronous Interface Only

The External Clock In Port is a 75-Ohm Female BNC Connector that is located on the Synchronous Interface Module only.

5.8 RD (J6)

The Receive Data Port (Unbalanced) is a 75-Ohm Female BNC Connector.

5.9 G.703 (J7)

The G.703 Interface Port (Balanced) is a 15-Pin Female “D” Connector. Refer to Table 5-1 for pinouts.

Table 5-1. G.703 Interface Port (Balanced) 15-Pin Female “D” Connector (J7)			
Pin No.	Signal Name	Signal	Direction
1	Send Data (-)	SD-A	Input
2	Ground	GND	---
9	Send Data (+)	SD-B	Input
7	External Clock A (-)	BAL EXC-A	Input
8	External Clock B (+)	BAL EXC-B	Input
3	Receive Data A (-)	RD-A	Output
4	Ground	GND	---
11	Receive Data B (+)	RD-B	Output
12	Drop Data Out (-)	DDO-A	Output
5	Drop Data Out (+)	DDO-B	Output
13	Insert Data In (-) EXC (-)	IDI-A	Input
6	Insert Data In (+) EXC (+)	IDI-B	Input

5.10 SYNC DATA (J8)

The Synchronous Data Interface Port is a 37-Pin Female “D” Connector. Refer to Table 5-2 for pinouts.

Table 5-2. Synchronous Data Port RS-422/RS-485/RS-232/V.35 37-Pin Female “D” Connector (J8)			
Pin No.	Signal Name	Signal	Direction
3	Transmit Octet (-)	TXO-A	Input
21	Transmit Octet (+)	TXO-B	Input
4	Send Data A (-)	SD-A	Input
22	Send Data B (+)	SD-B	Input
5	Send Timing A (-)	ST-A	Output
23	Send Timing B (+)	ST-B	Output
6	Receive Data A (-)	RD-A	Output
24	Receive Data B (+)	RD-B	Output
7	Request to Send A (-)	RS-A	Input
25	Request to Send B (+)	RS-B	Input
8	Receive Timing A (-)	RT-A	Output
26	Receive Timing B (+)	RT-B	Output
9	Clear to Send A (-)	CS-A	Output
10	Mod Fault - Open Collector	MF	Output

28	Demod Fault - Open Collector	DF	Output
27	Clear to Send B (+)	CS-B	Output
11	Data Mode A (-)	DM-A	Output
29	Data Mode B (+)	DM-B	Output
13	Receiver Ready A (-)	RR-A	Output
31	Receiver Ready B (+)	RR-B	Output
15	External Clock A (-)	BAL EXC-A	Input
33	External Clock B (+)	BAL EXC-B	Input
16	Receive Octet A (-)	RX-0-A	Output
34	Receive Octet B (+)	RX-0 B	Output
17	Terminal Timing A (-)	TT-A	Input
35	Terminal Timing B (+)	TT-B	Input
1, 19, 20, 37	Signal Ground	GND	---

5.11 ASYNC (J9)

The Asynchronous Data Interface Port is a 9-Pin Female “D” Connector. Refer to Table 5-3 for pinouts.

Table 5-3. Asynchronous Data Port 15-Pin Female “D” Connector (J9)			
Pin No.	Signal Name	Signal	Direction
1	Receive Data B	RXD_B	Output
2	Receive Data A	RXD_A	Output
3	Transmit Data A	TXD_A	Input
4	Transmit Data B	TXD_B	Input
5		GND	---
6		DSR	Output
7		RTS	Input
8		CTS	Output
9		NC	---

5.11 STATUS (J11)

The Modem Status Interface Port is a 15-Pin Female “D” Connector. Refer to Table 5-4 for pinouts.

Table 5-4. STATUS Data Port 15-Pin Female “D” Connector (J11)			
Pin No.	Signal Name	Signal	Direction
1	Mod Fault - C	MF-C	No Direction
2	Mod Fault – NC	MF-NC	No Direction
3	Mod Fault – NO	MF-NO	No Direction
4	Demod Fault - C	DF-C	No Direction
5	Demod Fault – NC	DF-NC	No Direction
6	Demod Fault – NO	DF-NO	No Direction
7	Common Equipment Fault - C	CEF-C	No Direction
8	Common Equipment Fault – NC	CEF-NC	No Direction
9	Common Equipment Fault – NO	CEF-NO	No Direction
10	Prompt – NO	SP1-NO	No Direction
11	Prompt – NC	SP1-NC	No Direction
12	Deferred – NO	SP2-NO	No Direction
13	Deferred – NC	SP2-NC	No Direction
14	AGC Out/Prompt – C (refer to Table 5-5)	SP1C/AGC	No Direction
15	Ground/Deferred – C (refer to Table 5-6)	SP2-C/GND	No Direction

Table 5-5. S6 AGC Out/Prompt – C Switch Positions			
AGC Out		Prompt - C	
1	On	1	Off
2	Off	2	On
3	X	3	X
4	X	4	X
5	X	5	X

Table 5-6. S6 Ground/Deferred – C Switch Positions			
AGC Out		Prompt - C	
1	X	1	X
2	X	2	X
3	On	3	Off
4	Off	4	On
5	X	5	X

5.13 TERMINAL (J12)

The Terminal Port is an RS-232 Connection that is used to connect a terminal for operating and monitoring the system. It is a 9-Pin Female “D” Connector. Refer to Table 5-7 for pinouts.

Table 5-7. Terminal Port (RS-232) 9-Pin Female “D” Connector (J12)			
Pin No.	Signal Name	Signal	Direction
3	Transmit Data	TxD	Output
2	Receive Data	RxD	Input
5	Ground	GND	---
7	Request to Send	RTS	Input
8	Clear to Send	CTS	Input

5.14 REMOTE (J13)

The Remote Port is a RS-485 Connection for remote monitor and control of the modem. It is a 9-Pin Female “D” Connector. Refer to Table 5-8 for pinouts.

Table 5-8. Remote Port RS-485 9-Pin Female “D” Connector (J13)			
Pin No.	Signal Name	Signal	Direction
1	Transmit Data B	RS-485 TxD-B	Output
2	Transmit Clock A	TxC-A	Output
3	Transmit Clock B	TxC-B	Output
4	Receive Clock A	RxC-A	Input
5	Signal Common	Common	---
6	Transmit Data A	RS-485 TxD-A	Output
7	Receive Clock B	RxC-B	Input
8	Receive Data B	RS-485 RxD-B	Input
9	Receive Data A	RS-485 RxD-A	Input

5.15 ESC 8K DATA (J15)

The ESC (Engineering Service Circuits) 8K Data Port allows for communications between Earth Stations. It is a 15-Pin Female “D” Connector. Refer to Table 5-9 for pinouts.

Table 5-9. ESC 8K Data Port 15-Pin Female “D” Connector (J15)			
Pin No.	Signal Name	Signal	Direction
1	Receive Octet-B	ESCRXO-B	Output
2	Receive Clock-B	ESCRXC-B	Output
3	Receive Data-B	ESCRXD-B	Output
4	No Connection	NC	---
5	No Connection	NC	---
6	Transmit Data-A	ESCTXD-A	Input
7	Transmit Clock-A	ESCTXC-A	Output
8	Transmit Octet-A	ESCTXO-A	Output
9	Receive Octet-A	ESCRXO-A	Output
10	Receive Clock-A	ESCRXC-A	Output
11	Receive Data-A	ESCRXD-A	Output
12	Ground	GND	---
13	Transmit Data-B	ESCTXD-B	Input
14	Transmit Clock-B	ESCTXC-B	Output
15	Transmit Octet-B	ESCTXO-B	Output

5.16 ESC VOICE (J16)

The ESC Voice Port allows for communications between Earth Stations. It is a 9-Pin Female “D” Connector. Refer to Table 5-10 for pinouts.

Table 5-10. J16-ESC Audio/64K Data-9-Pin Female ‘D’					
Pin No.	Signal	Audio		64K	
		Description	Direction	Description	Direction
1	ESCAUDTX 1A	Tx Audio 1A	Input	Tx Data 64K A	Input
2	ESCAUDRX 1A	Rx Audio 1A	Output	Rx Data 64K A	Output
3	GND	Ground		Ground	
4	ESCAUDTX 2B	Tx Audio 2B	Input	Tx Clock 64K B	Output
5	ESCAUDRX 2B	Rx Audio 2B	Output	Rx Clock 64K B	Output
6	ESCAUDTX 1B	Tx Audio 1B	Input	Tx Data 64K B	Input
7	ESCAUDRX 1B	Rx Audio 1B	Output	Rx Data 64K B	Output
8	ESCAUDTX 2A	Tx Audio 2A	Input	Tx Clock 64K A	Output
9	ESCAUDRX 2A	Rx Audio 2A	Output	Rx Clock 64K A	Output

5.17 ESC ALARMS (J17)

The ESC Alarms Port is a 25-Pin Female “D” Connector. Refer to Table 5-11 for pinouts.

Table 5-11. ESC Alarms Port 25-Pin Female “D” Connector (J17)			
Pin No.	Signal Name	Signal	Direction
1	Ground	GND	---
2	Backward Alarm Out - 1NO	ESCBWO 1NO	N/A
3	No Connection	NC	---
4	Backward Alarm Out - 2 NO	ESCBWO 2NO	N/A
5	No Connection	NC	---
6	Backward Alarm Out - 3 NO	ESCBWO 3NO	N/A
7	Ground	GND	---
8	Backward Alarm Out - 4 NO	ESCBWO 4NO	N/A
9	No Connection	NC	---
10	Backward Alarm In - 2	ESCBWI 2	Input
11	Backward Alarm In - 4	ESCBWI 4	Input
12	No Connection	NC	---
13	No Connection	NC	---
14	Backward Alarm Out - 1 C	ESCBWO 1C	N/A
15	Backward Alarm Out - 1 NC	ESCBWO 1NC	N/A
16	Backward Alarm Out - 2 C	ESCBWO 2C	N/A
17	Backward Alarm Out - 2 NC	ESCBWO 2NC	N/A

18	Backward Alarm Out - 3 C	ESCBWO 3C	N/A
19	Backward Alarm Out - 3 NC	ESCBWO 3NC	N/A
20	Backward Alarm Out - 4 C	ESCBWO 4C	N/A
21	Backward Alarm Out - 4 NC	ESCBWO 4NC	N/A
22	Backward Alarm In – 1	ESCBWI 1	Input
23	Backward Alarm In – 3	ESCBWI 3	Input
24	No Connection	NC	---
25	No Connection	NC	---

5.18 SWITCH (J18)

The Switch Port is a 68-Pin High-Density Female Connector. Refer to Table 5-12 for pinouts.

Table 5-12. Switch Port 68-Pin High-Density Female Connector (J18)			
Pin No.	Signal Name	Signal	Direction
1	G.703 Send Data Input A	G.703B SD-A	Input
2	Synchronous Data Send Data Input - A	SYNC SD-A	Input
3	IDR ESC Backward Alarm Out - 1 Common	ESCBWO 1C	---
4	G.703 Insert Data Input – A	G.703B IDI-A	Input
5	Synchronous Data Send Timing Output – A	SYNC ST-A	Output
6	IDR ESC Backward Alarm Out - 1 Normally Open	ESCBWO 1NO	Input
7	Synchronous Data Terminal Timing Input – A	SYNC TT-A	Input
8	IDR ESC Backward Alarm Out - 2 Normally Closed	ESCBWO 2NC	---
9	G.703 Drop Data Out A - Synchronous Data Receive Timing Output - A	DDO-A RT-A	Output
10	IDR ESC Backward Alarm Output - 3 Common	ESCBWO 3C	---
11	G.703 Insert Data Out A - Synchronous Data Receive Data A	IDO-A RD-A	Output
12	IDR ESC Backward Alarm Output - 3 Normally Open	ESCBWO 3NO	---
13	External Clock Input - A	BAL EXC-A	Input
14	Ground	GND	---
15	IDR ESC Audio Input Channel 1A	ESCAUDTX 1A	Input

16	IDR ESC Audio Input Channel 2A	ESCAUDTX 2A	Input
17	IDR ESC Audio Output Channel 1A	ESCAUD RX 1A	Output
18	IDR ESC Audio Output Channel 2A	ESCAUD RX 2A	Output
19	IDR ESC Backward Alarm Input - 3	ESCBWI 3	Input
20	IBS ES Transmit Data A IDR ESC Backward Alarm Input 1	TXD-A BWI 1	Input
21	Mod Fault Open Collector Output	MOD FLT	Output Open Collector
22	IBS ES Receive Data Output - A	ES RXD-A	Output
23	IBS ES Data Set Ready (RS-232 Only)	ES DSR	Output
24	IDR ESC Transmit 8 Kbps Output Clock	ESCTXC-A	Output
25	IDR ESC Transmit 8 Kbps Output Data	ESCTXD-A	Input
26	IDR ESC Receive 8 Kbps Output Clock	ESCRXC-A	Output
27	IDR ESC Receive 8 Kbps Output Data	ESCRXD-A	Output
28	IDR ESC Backward Alarm Output - 4 Normally Closed	ESCBWO 4NC	---
29	IBS Transmit Octet Input - A	TXO-A	Input
30	Synchronous Data Mode A	SYNC DM-A	Output
31	Synchronous Data Clear to Send - A	SYNC CS-A	Output
32	IBS Receive Octet Output - A	RXO-A	Output
33	Synchronous Data Request to Send - A	SYNC RS-A	Input
34	Synchronous Data Receiver Ready - A	SYNC RR-A	Output
35	G.703 Send Data Input - B	G703B SD-B	Input
36	Synchronous Data Send Data Input - B	SYNC SD-B	Input
37	IDR ESC Backward Alarm Out - 1 Normally Closed	ESCBWO 1 NC	---
38	G.703 Insert Data Input - B	G703B IDI-B	---
39	Synchronous Data Send Timing Output - B	SYNC ST-B	---
40	IDR ESC Backward Alarm Out - 2 Common	ESCBWO 2C	---

41	Synchronous Data Terminal Timing – B	SYNC TT-B	---
42	IDR ESC Backward Alarm Output - 2 Normally Open	ESCBWO 2NO	---
43	G.703 Drop Data Out - B Synchronous Data Receive Timing – B	DDO-B RT-B	---
44	IDR ESC Backward Alarm Out - 3 Normally Closed	ESCBWO 3NC	---
45	G.703 Insert Data Out Synchronous Data	IDO-B RD-B	---
46	IDR ESC Backward Alarm Out - 4 Common	ESCBWO 4C	---
47	External Clock Input - B	BAL EXC-B	Input
48	Ground	GND	---
49	IDR ESC Audio Input Channel - 1B	ESCAUDTX 1B	Input
50	IDR ESC Audio Input Channel - 2B	ESCAUDTX 2B	Input
51	IDR ESC Audio Output Channel - 1B	ESCAUDRX 1B	Output
52	IDR ESC Audio Output Channel - 2B	ESCAUDRX 2B	Output
53	IDR ESC Backward Alarm Input - 4	ESCBWI 4	---
54	IBS ES Transmit Data – B IDR ESC Backward Alarm Input - 2	TX-B BWI 2	Input
55	Demod Fault Open Collector Output	DMD FLT	Output Open Collector
56	IBS ES Receive Data Input - B	ES RXD-B	Output
57	Ground	GND	---
58	IDR ESC Transmit 8 Kbps Output Clock - B	ESCTXC-B	Output
59	IDR ESC Transmit 8 Kbps Output Data - B	ESCTXD-B	Input
60	IDR ESC Receive 8 Kbps Clock Output - B	ESCRXC-B	Output
61	IDR ESC Receive 8 Kbps Data Output - B	ESCRXD-B	Output
62	IDR ESC Backward Alarm Out - 4 Normally Open	ESCBWO 4NO	---
63	IBS Transmit Octet Input - B	TXO-B	Input

64	Synchronous Data – Data Mode Out - B	SYNC DM-B	Output
65	Synchronous Data - Clear to Send - B	SYNC CS-B	Input
66	IBS Receive Octet Output - B	RXO-B	Output
67	Synchronous Data Request to Send – B	SYNC RS-B	Input
68	Synchronous Data Receiver Ready - B	SYNC RR-B	Output



Section 6 – Maintenance

6.0 Periodic Maintenance

The DMD15/DMD15L modulator requires no periodic field maintenance procedures. Should a unit be suspected of a defect in field operations after all interface signals are verified, the correct procedure is to replace the unit with another known working DMD15/DMD15L. If this does not cure the problem, wiring or power should be suspect.

There is no external fuse on the DMD15/DMD15L. The fuse is located on the power supply assembly inside the case, and replacement is not intended in the field.

6.1 Troubleshooting

The following is a brief list of possible problems that could be caused by failures of the modem or by improper setup and configuration for the type of service. The list is arranged by possible symptoms exhibited by the modem.

Symptom: The Modem will not acquire the incoming carrier:

Possible Cause: Improper receive input to modem.

Action: Check that the receive cabling is correct.

Possible Cause: Receive carrier level too low.

Action: Check that the receive cabling is correct, that the downconverter is properly set and that the LNA is turned on. If a spectrum analyzer is available, locate and measure the receive level, which should not be below -65 dBm absolute, -50 dBm is nominal.

Possible Cause: Receive carrier frequency outside of acquisition range.

Action: Check that the receive acquisition range is adequate for the possible system offsets. Setting the value to 30 kHz is a standard value encompassing all normal offsets. After acquisition, the actual receive frequency can be read from the Front Panel.

Possible Cause: Transmit carrier incompatible.

Action: Check the receive parameter settings and ensure that they match those on the modulator.

Possible Cause: Modem is in Test Mode.

Action: Check the modem Front Panel for yellow warning LEDs indicating a Test Mode is enabled. Self-Test or IF Loopback disconnects the Demodulator from the IF receive input connector.

Symptom: The Async Port is not configured correctly.

Action: Refer to Section 5.8 to correctly set switches for correct configuration.

6.2 DMD15/DMD15L Fault Philosophy

The DMD15/DMD15L performs a high degree of self-monitoring and fault isolation. The alarms are separated into three categories; Active Alarms, Common Equipment Alarms, and Latched Alarms. In addition, a feature exists that allows the user to 'Mask' out certain Alarms as explained below. Alarms that are recorded in the event buffer are the same as the alarm buffer.



Masking alarms can cause undesirable modem performance.

6.2.1 Alarm Masks

The user has the capability to 'Mask' individual alarms on the DMD15/DMD15L. When an Alarm is masked, the Front Panel LEDs and the Fault Relays do not get asserted, but the Alarm will still be displayed. This feature is very helpful during debugging or to lock out a failure that the user is already aware of.

6.2.2 Active Alarms

6.2.2.1 Major Alarms

Major alarms indicate a modem hardware failure. Major alarms may flash briefly during modem configuration changes and during power-up but should not stay illuminated. Alarms are grouped into Transmit alarms and Receive alarms - Transmit and Receive are completely independent.

6.2.2.2 Minor Alarms

Minor alarms indicate that a problem may persist outside the modem such as loss of Terrestrial Clock, loss of terrestrial data activity, or a detected transmit or receive AIS condition. Alarms are grouped into Transmit Alarms and Receive Alarms - Transmit and Receive are completely independent.

6.2.2.3 Latched Alarms

Latched alarms are used to catch intermittent failures. If a fault occurs, the fault indication will be latched even if the alarm goes away. After the modem is configured and running, it is recommended that the latched alarms be cleared as a final step.

6.3 DMD15/DMD15L Fault Tree Matrices

Tables 6-1 through 6-3 represent, in matrix form, the faults that may occur within the DMD15/DMD15L. There are three matrices: Interface/Common Equipment Faults, Tx Faults and Rx Faults.

INTERFACE/COMMON EQUIPMENT FAULTS	TX IF OUTPUT OFF	TX MAJOR ALARM LED	TX AIS	RX FAULT LED	RX MINOR ALARM LED	RX MAJOR ALARM LED	RX AIS	MOD FAULT RELAY	DEMOM FAULT RELAY	COM EQUIP FAULT RELAY	SW COM EQUIP FAULT RELAY	MINOR ALARM RELAY	IBS BACKWARD ALARM	SWITCH BACK TO INTERNAL	SIGNAL LOCK LED	TX BACKWARD ALARM	TX ON LED	FAULT LED	BOTH MOD AND DEMOM FAULT OPEN COLLECTOR	SW BUFF CLK TO BACKUP	SW TX CLK TO BACKUP
+5V OUT OF RANGE																					
+12V OUT OF RANGE																					
-12V OUT OF RANGE																					
TEMP. OUT OF RANGE																					
NO EXT IF REF ACTIVITY																					

Table 6-1. DMD15/DMD15L Interface/Common Equipment Fault Matrix

RX FAULTS	RX MINOR ALARM LED	RX MAJOR ALARM LED	RX AIS	MOD FAULT RELAY	DEMOM FAULT RELAY	COM EQUIP FAULT RELAY	SW COM EQUIP FAULT RELAY	IBS BACKWARD ALARM	RESERVED	RESERVED	SIGNAL LOCK LED OFF	DEMOM FAULT OPEN COLLECTOR
SIGNAL LOSS												
RX IF SYNTH UNLOCKED												
RX DATA AIS RCVD.												
RX SIG LEVEL LOW												
VITERBI UNLOCKED												
SEQ UNLOCKED												
BER THRESHOLD REACHED												
BUFFER OVERFLOWS												
BUFFER UNDERFLOWS												
BUFFER PLL UNLOCKS												

Conditional When Sequential is Used

Table 6-2. DMD15/DMD15L RX Fault Matrix

TX FAULTS	TX IF OUTPUT OFF	TX MINOR ALARM LED	TX MAJOR ALARM LED	TX AIS	MOD FAULT RELAY	DEMOD FAULT RELAY	MOD FAULT OPEN COLLECTOR	OVERRIDE TO INTERNAL REF
TX IF SYNTH UNLOCKED	■		■		■			
TX CLOCK ACT		■		■				
TX COMP CLK PLL UNLOCKED	■		■		■			
TX OUTPUT LEVEL	■		■		■			
NO TX DATA ACTIVITY		■		■				
TX AIS RCVD		■		■				
TX OVERSMPL PLL UNLOCKED	■		■		■			
TX FIR COEFF ERROR	■		■		■			
TX FPGA CONFIG ERROR	■		■		■			
TX LOSS OF EXTERNAL REF		■		■				■
LOSS EXT REF								■

Table 6-3. DMD15/DMD15L TX Fault Matrix

6.3.1 Interpreting the Matrices

The first vertical column in the Tables represents the various Faults that the modem may identify. The top horizontal column indicates the various actions that the modem will undertake. These actions may be in the form of a relay, a switch or an LED.

6.3.2 IBS Fault Conditions and Actions

Figure 6-10 and Table 6-4 illustrates the IBS Fault Conditions and Actions to be taken at the Earth Station, at the Terrestrial Data Stream, and the Satellite. These faults include those detected on the Terrestrial link and those detected from the satellite.

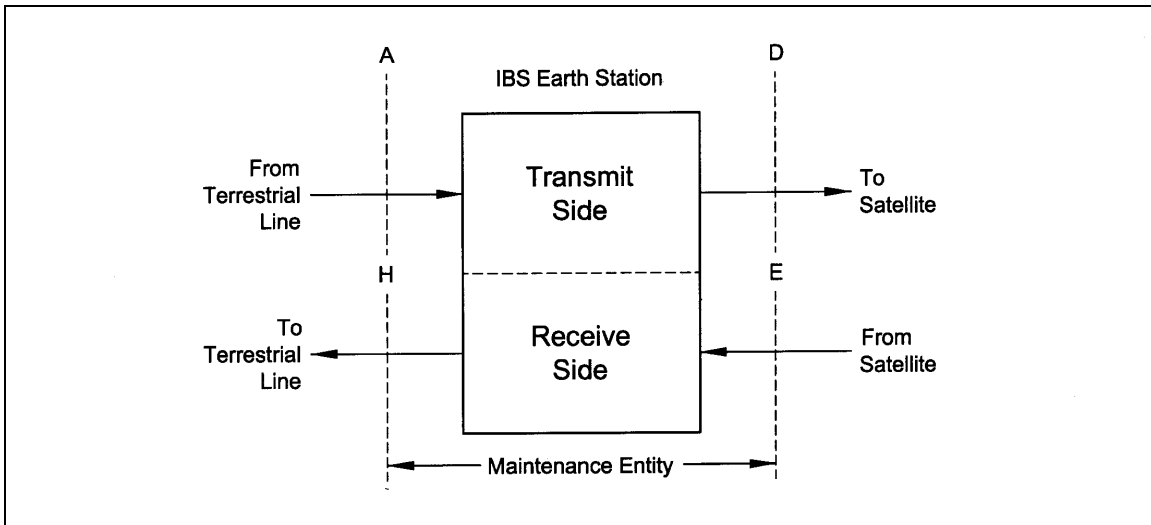

Figure 6-10. IBS Alarm Concept

Table 6-4. IBS Fault Conditions and Actions (includes Drop and Insert)			
Fault Detected on Terrestrial Link (Across Interface A)	Action In Earth Station	Action to Terrestrial (Across Interface H)	Action to Satellite (Across Interface D)
FA1 - Loss of Terrestrial Input	AS1, 2 - IBS Prompt, Service Alarm	AH2 - '1' in Bit 3 of NFAS TSO, Yellow Alarm	AD1 - AIS in Relevant TS's
FA2 - Loss of Terrestrial Signaling	AS1 - - IBS Prompt Alarm	AH2 - '1' in Bit 3 of NFAS TSO, Yellow Alarm	AD3 - '1111' in Relevant TS16's
FA3 - Loss of Terrestrial Frame	AS1 - - IBS Prompt Alarm	AH2 - '1' in Bit 3 of NFAS TSO, Yellow Alarm	AD1 - AIS in Relevant TS's
FA4 - Loss of Terrestrial Multiframe	AS1 - IBS Prompt Alarm	AH2 - '1' in Bit 3 of NFAS TSO, Yellow Alarm	AD3 - '1111' in Relevant TS16's
FA5 - BER of 1×10^{-3} or Greater on Terrestrial Input	AS1 - IBS Prompt Alarm	AH2 - '1' in Bit 3 of NFAS TSO, Yellow Alarm	AD1 - AIS in Relevant TS's
FA6 - Alarm Indication Received on Terrestrial Input	---	---	AD2 - '1' in Bit 3 of Byte 32
Fault Detected From Satellite (Across Interface E)			
FA1 - Loss of Satellite Signal Input	AS1,2 - IBS Prompt, Service Alarm	AH1, 3 - AIS in TS's, '1111' in TS16	AD2 - '1' in Bit 3 of Byte 32

FA2 - Loss of Satellite Frame	AS1,2 - IBS Prompt, Service Alarm	AH1, 3 - AIS in TS's, '1111' in TS16	AD2 - '1' in Bit 3 of Byte 32
FA3 - Loss of Satellite Multiframe	AS1,2 - IBS Prompt, Service Alarm	AH1, 3 - AIS in TS's, '1111' in TS16	AD2 - '1' in Bit 3 of Byte 32
FA4 - BER of 1E-3 or Greater From Satellite Input	AS1,2 - IBS Prompt, Service Alarm	AH1, 3 - AIS in TS's, '1111' in TS16	AD2 - '1' in Bit 3 of Byte 32
FA5 - Alarm Indication Received From Satellite Input	AS2 - IBS Service Alarm	AH2 - '1' in Bit 3 of NFAS TS0, Yellow Alarm	---

Section 7 – Technical Specifications

7.0 Modulator Specifications

Modulation:	BPSK and QPSK (OQPSK, 8PSK, 16QAM optional)
Data Rates:	9.6 Kbps to 10 Mbps in 1 bps steps
Symbol Rates:	6300 to 6500000 Symbols per second 128000 to 6500000 Symbols per second (8PSK/16QAM)
IF Tuning Range:	50 to 90, 100 to 180 MHz in 1 Hz steps 950 – 1750 MHz (optional L-Band)
IF Impedance:	75 Ohms, 50 Ohms (optional) 50 Ohms (optional L-Band)
IF Connector:	BNC, (L-Band, SMA)
IF Return Loss:	20 dB minimum (13 dB L-Band)
Output Power:	-20 to +5.0 dB in 0.1 dB steps (L-Band -5 to -30 dB)
Output Stability:	±0.5 dB over time and temperature
Output Spectrum:	Meets IESS 308/309/310 Power Spectral mask
Spurious	< -55 dBc in any 4 kHz band
On/Off Power Ratio:	> 60 dB
Scrambler:	CCITT V.35 or IBS (others optional)
FEC:	Viterbi, K = 7 at 1/2, 3/4 and 7/8 Rate Sequential 1/2, 3/4, 7/8 (optional) Trellis 2/3 (optional) Turbo Product Code (optional) Rate 3/4 (0.793) - (64, 57) x (64, 57) Rate 1/2 (0.495) - (32,26) x (32,26) x (4,3) (Turbo supported at all modulation types)
Outer Encoder Options:	Reed-Solomon INTELSAT Rates
Data Clock Source:	Internal, External, Rx Recovered
Internal Stability:	1 x 10 ⁻⁶ Typical (optional to 1 x 10 ⁻⁷)

7.1 Demodulator Specifications

Demodulation:	BPSK and QPSK (OQPSK, 8PSK, 16QAM optional)
Data Rates:	9.6 Kbps to 10 Mbps, 1 bps steps
Symbol Rates:	12696 to 6500000 Symbols per second (B/O/QPSK) 128000 to 6500000 Symbols per second (8PSK/16QAM)
IF Tuning Range:	50 to 90, 100 to 180 MHz in 1 Hz steps 950 to 1750 MHz (optional L-Band)
IF Impedance:	75 Ohms, 50 Ohms (optional) 50 Ohms (optional L-Band)
IF Connector:	BNC, SMA (optional L-Band)
IF Return Loss:	20 dB minimum
Spectrum:	INTELSAT IESS 308/309/310 compliant
Input Level:	-55 to -25 dBm
Adjacent Channel Rejection Ratio:	> +14 dBc
Total Input Power:	+10 dBm or +40 dBc (the lesser)

FEC: Viterbi, K = 7 at 1/2, 3/4, and 7/8 Rate,
Rate Sequential 1/2, 3/4, 7/8 (optional)
Trellis 2/3 (Optional)
Turbo Product Code (Optional)
 3/4 Rate (0.793) - (64,57) x (64,57)
 1/2 Rate (0.495) - (32,26) x (32,26) x (4,3)
(Turbo supported at all modulation types)

Decoder Options: Reed-Solomon
Descrambler: CCITT V.35 or IBS (others optional)
Acquisition Range: Programmable ± 1 kHz to ± 32 kHz
Sweep Delay Value: 0 sec to 900.0 sec. in 100 msec. Steps
Reacquisition sweep: 0 to 32000 Hz in 1 Hz steps.

7.2 Plesiochronous Buffer

Size: 2 ms to 32 ms
Centering: Automatic on underflow/overflow
Centering Modes: IBS: Integral number of frames
IDR: Integral number of multiple frames
Clock: Transmit, External, Rx Recovered or SCT (Internal)

7.3 Monitor and Control

Transmit and Receive Frequencies
Transmit and Receive Data Rates and Code Rate
Differential Encoding On/Off
Scrambler On/Off
Spectrum Normal/Inverted
Clock Source, Polarity and Frequency
Transmit Carrier On/Off and Tx Level
Tx Test Modes
Demodulator Input Level
 E_b/N_o
Buffer Size, Clock, Center Buffer
Sweep Range and Delay
IDR/IBS Backward Alarms, Modem/Switch Alarms
IDR/IBS Framing, Drop and Insert Mode and Flags
Loopback; Terrestrial and Satellite

7.4 DMD15/DMD15L Drop and Insert (Optional)

Terrestrial Data: 1.544 Mbps or 2.048 Mbps, G.732/733
Line Coding: AMI or B8ZS for T1 and HDB3 for E1
Framing: D4, ESF, or SLC-96 for T1 and PCM30 (30 channels) or
PCM31 (31 channels for E1).
Time Slot Selection: n x 64 contiguous or arbitrary blocks for Drop or Insert.
Time Slots: TS1, 2, 3, 4, 5, 6, 8, 10, 12, 15, 16, 20, 24, 30
Data Rates: 64, 128, 192, 256, 320, 384, 512, 640, 768, 960, 1024, 1280,
1536, 1920 Kbps

7.5 Terrestrial Interfaces

A variety of standard interfaces is available for the DMD15/DMD15L Modem in stand-alone applications.

7.6 Universal Interface

Module (UIM):	User Selectable RS-422/449, V.35, T1(DSX1, T2 (DSX2, E1 (G.703), and E2 (G.703)
G.703 T1 (DSX1):	1.544 Mbps, 100 Ohm balanced, AMI and B8ZS
G.703 E1:	2.048 Mbps, 75 Ohm unbalanced, and 120 Ohm balanced, HDB3
G.703 T2 (DSX2):	6.312 Mbps, 75 Ohm unbalanced, and 110 Ohm balanced, B8ZS and B6ZS
G.703 E2:	8.448 Mbps, 75 Ohm BNC, unbalanced, HDB3
ITU V.35:	Differential, Clock and Data only
RS-422/-449:	All Rates, Differential, Clock/Data, DCE (50 Ohm options are also available)
RS-232	DCE up to 200 Kbps

7.7 Environmental

Prime Power:	100 – 240 VAC, 50 – 60 Hz, 1.0 A maximum. 48 VDC (IEC) 3-Pin Power Connector with Switch
Operating Temperature:	0 to 50°C, 95% humidity, non-condensing
Storage Temperature:	-20 to 70°C, 99% humidity, non-condensing

7.8 Physical

Chassis size:	19" W x 22" D x 1.75" H (48.26 x 43.18 x 4.45 cm)
Weight:	9.6 pounds (4.3 Kg)

7.9 DMD15 Data Rate Limits

	Modulator		Demodulator	
	Low	High	Low	High
BPSK NONE	6300	6500000	12695	6500000
BPSK 1/2	3150	3250000	6347	3250000
BPSK 3/4	4725	4875000	9521	4875000
BPSK 7/8	5512	5687500	11108	5687500
BPSK 495	3113	3211988	6273	3211988
BPSK 793	4987	5145833	10050	5145833
QPSK NONE	12600	10000000	25390	10000000
QPSK 1/2	6300	6500000	12695	6500000
QPSK 3/4	9450	9750000	19042	9750000
QPSK 7/8	11025	10000000	22216	10000000
QPSK 495	6226	6423976	12546	6423976
QPSK 793	9975	10000000	20100	10000000
OQPSK NONE	12600	10000000	25390	10000000
OQPSK 1/2	6300	6500000	12695	6500000
OQPSK 3/4	9450	9750000	19042	9750000
OQPSK 7/8	11025	10000000	22216	10000000
OQPSK 495	6226	6423976	12546	6423976
OQPSK 793	9975	10000000	20100	10000000
8PSK 2/3	256000	10000000	256000	10000000
8PSK 495	256000	9635964	256000	9635964
8PSK 793	304000	10000000	304000	10000000
16QAM 3/4	384001	10000000	384001	10000000
16QAM 7/8	448001	10000000	448001	10000000
16QAM 495	253006	10000000	253006	10000000
16QAM 793	405334	10000000	405334	10000000

7.10 DMD15 BER Specifications

Modem BER Performance (Viterbi)

	Specification			Typical			
	IBS	IDR	IDR	IBS	IBS	IDR	IDR
	1/2 Rate	3/4 Rate	7/8 Rate	1/2 Rate	3/4 Rate	3/4 Rate	7/8 Rate
10^{-3}	4.1 dB	5.2 dB	6.2 dB	3.25 dB	4.2 dB	4.35 dB	5.8 dB
10^{-4}	4.6 dB	6.0 dB	7.1 dB	3.8 dB	4.9 dB	5.25 dB	6.5 dB
10^{-5}	5.3 dB	6.7 dB	7.9 dB	4.6 dB	5.6 dB	5.9 dB	7.2 dB
10^{-6}	6.0 dB	7.5 dB	8.6 dB	5.2 dB	6.3 dB	6.6 dB	7.9 dB
10^{-7}	6.6 dB	8.2 dB	9.3 dB	5.9 dB	6.9 dB	7.3 dB	8.6 dB
10^{-8}	7.1 dB	8.7 dB	10.2 dB	6.4 dB	7.5 dB	7.8 dB	9.4 dB

8PSK Trellis Decoder 8PSK

BER	Specification	Typical
	2/3 Rate	2/3 Rate
10^{-3}	6.2 dB	5.6 dB
10^{-4}	7.0 dB	6.4 dB
10^{-5}	7.8 dB	7.2 dB
10^{-6}	8.7 dB	8.1 dB
10^{-7}	9.5 dB	8.9 dB
10^{-8}	10.2 dB	9.7 dB

Trellis Decoder and Reed-Solomon

BER	Specification	Typical
	8PSK 2/3 Rate	8PSK 2/3 Rate
10^{-4}	5.5 dB	5.1 dB
10^{-5}	5.8 dB	5.4 dB
10^{-6}	6.2 dB	5.6 dB
10^{-7}	6.5 dB	5.8 dB
10^{-8}	6.7 dB	6.1 dB
10^{-9}	6.9 dB	6.3 dB

Sequential Decoder BER Performance (1.544 Mbps)

BER	Specification			Typical		
	1/2 Rate	3/4 Rate	7/8 Rate	1/2 Rate	3/4 Rate	7/8 Rate

10^{-3}	4.8 dB	5.2 dB	6.0 dB	4.3 dB	4.7 dB	5.5 dB
10^{-4}	5.2 dB	5.7 dB	6.4 dB	4.7 dB	5.2 dB	5.9 dB
10^{-5}	5.6 dB	6.1 dB	6.9 dB	5.1 dB	5.6 dB	6.4 dB
10^{-6}	5.9 dB	6.5 dB	7.4 dB	5.4 dB	6.1 dB	6.9 dB
10^{-7}	6.3 dB	7.0 dB	7.9 dB	5.8 dB	6.5 dB	7.4 dB
10^{-8}	6.7 dB	7.4 dB	8.4 dB	6.2 dB	6.9 dB	7.9 dB

Concatenated Reed-Solomon Performance (BER Specifications)

BER vs. E_b/N_o	Guaranteed Performance	
	Rate 1/2 FEC	Rate 3/4 FEC
10^{-6}	4.1	5.6
10^{-7}	4.2	5.8
10^{-8}	4.4	6.0
10^{-10}	5.0	6.3

16 QAM BER Performance (Viterbi Decoder)

BER	Specification			Typical		
	1/2 Rate	3/4 Rate	7/8 Rate	1/2 Rate	3/4 Rate	7/8 Rate
10^{-3}	n/a	8.9 dB	10.3 dB	n/a	8.1 dB	9.5 dB
10^{-4}	n/a	9.8 dB	11.1 dB	n/a	9.0 dB	10.3 dB
10^{-5}	n/a	10.7 dB	11.9 dB	n/a	9.9 dB	11.1 dB
10^{-6}	n/a	11.5 dB	12.7 dB	n/a	10.7 dB	11.9 dB
10^{-7}	n/a	12.4 dB	13.5 dB	n/a	11.6 dB	12.7 dB
10^{-8}	n/a	13.3 dB	14.3 dB	n/a	12.5 dB	13.5 dB

16 QAM BER Performance (Viterbi Decoder w/ Reed-Solomon)

BER	Specification			Typical		
	1/2	3/4	7/8	1/2	3/4	7/8
10^{-3}	n/a	8.4 dB	9.8 dB	n/a	7.8 dB	9.3 dB
10^{-4}	n/a	8.6 dB	10.1 dB	n/a	8.1 dB	9.6 dB
10^{-5}	n/a	8.9 dB	10.3 dB	n/a	8.3 dB	9.9 dB

10^{-6}	n/a	9.1 dB	10.5 dB	n/a	8.6 dB	0.2 dB
10^{-7}	n/a	9.3 dB	10.8 dB	n/a	8.8 dB	10.4 dB
10^{-8}	n/a	9.5 dB	11.0 dB	n/a	9.1 dB	10.7 dB

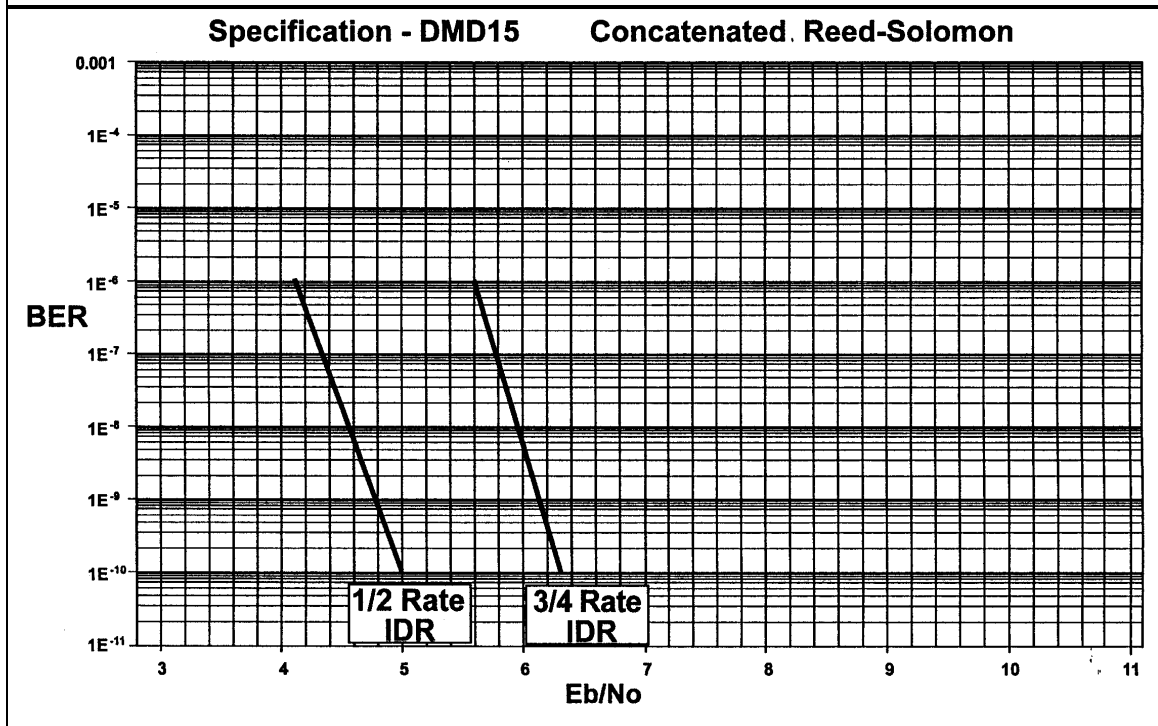
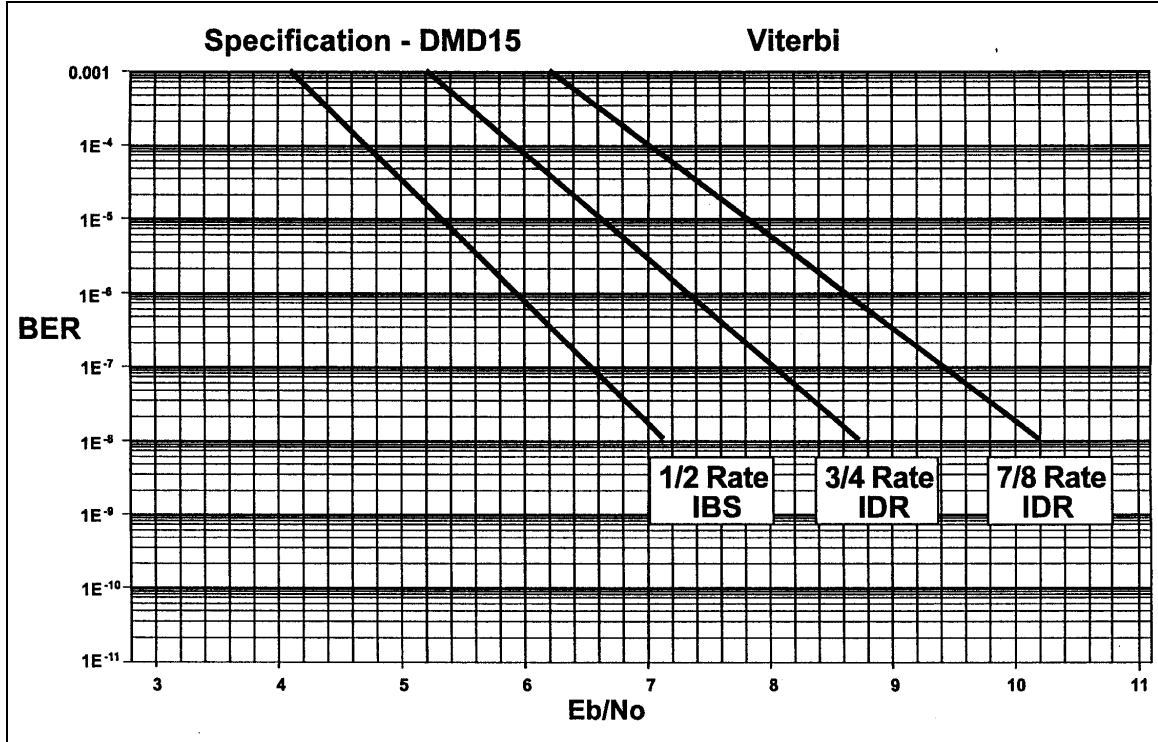

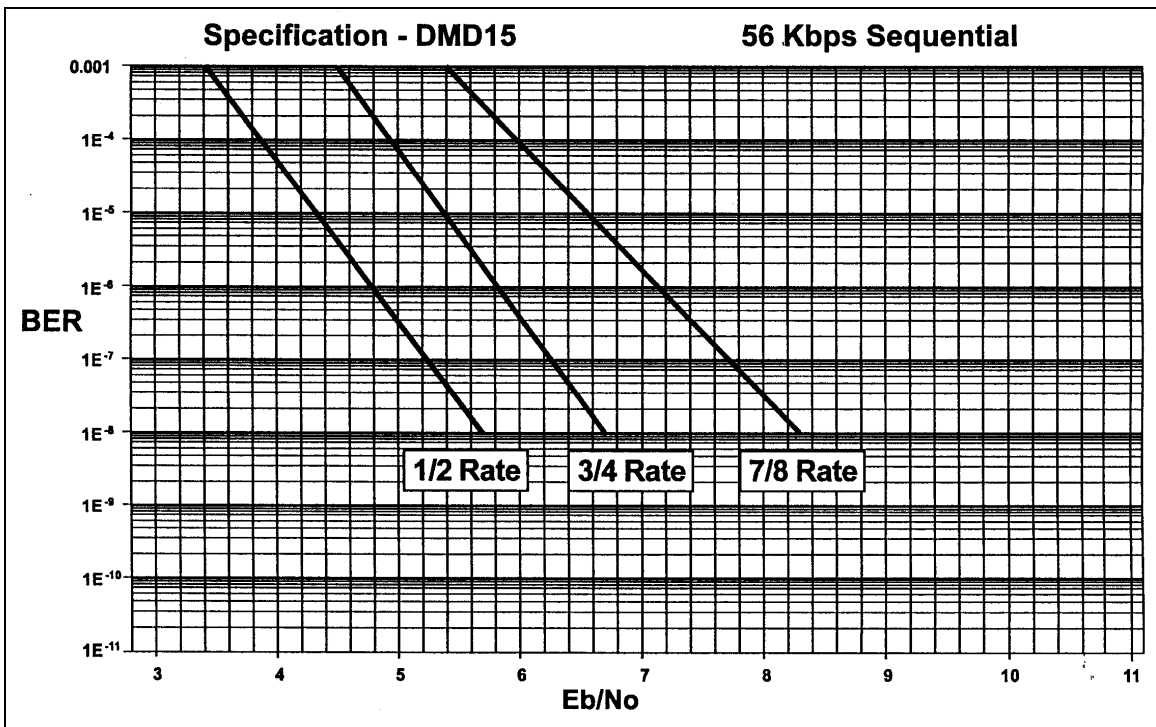
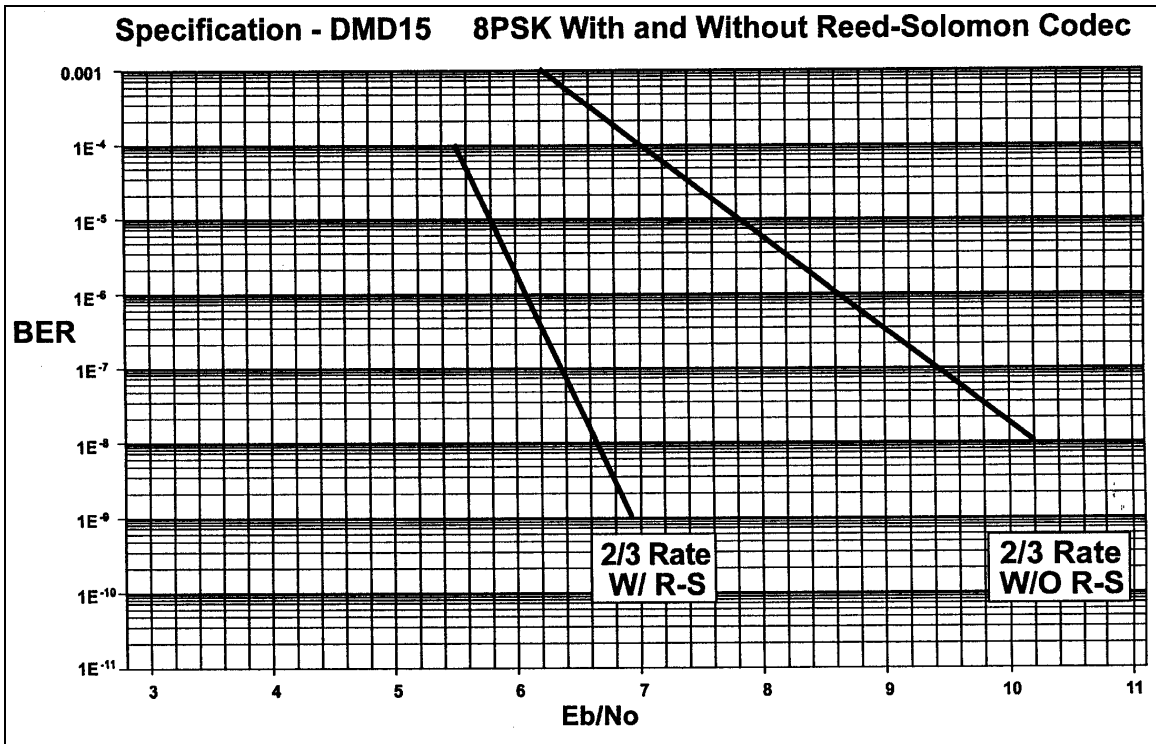

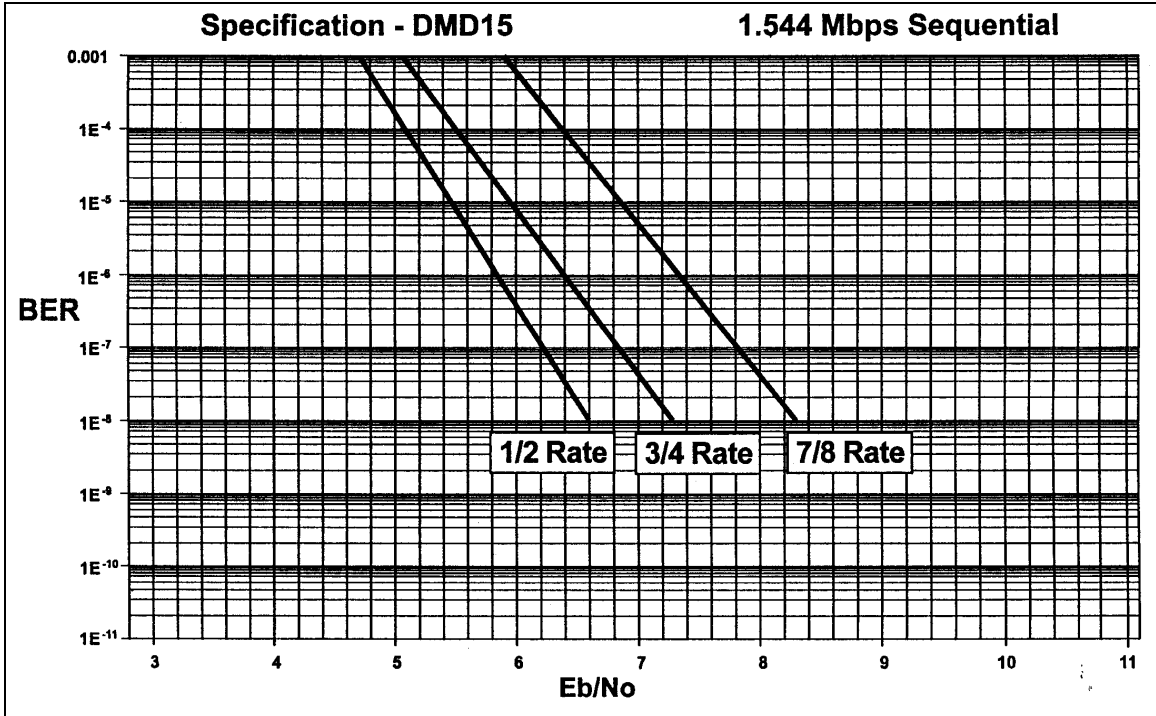



Section 8 – Appendices

Appendix A – Reed-Solomon Codes

<u>n</u>	<u>Valid Values for k</u>
2	1
3	2
4	2, 3
5	3, 4
6	3, 4, 5
7	4, 5, 6
8	4, 6, 7
9	5, 6, 7, 8
10	5, 7, 8, 9
11	6, 8, 9, 10
12	6, 8, 9, 10, 11
13	7, 9, 10, 11, 12
14	7, 10, 11, 12, 13
15	8, 10, 12, 13, 14
16	8, 11, 12, 13, 14, 15
17	9, 12, 13, 14, 15, 16
18	9, 12, 14, 15, 16, 17
19	10, 13, 15, 16, 17, 18
20	10, 14, 15, 16, 17, 18, 19
21	11, 14, 16, 17, 18, 19, 20
22	11, 15, 17, 18, 19, 20, 21
23	12, 16, 18, 19, 20, 21, 22
24	12, 16, 18, 20, 21, 22, 23
25	13, 17, 19, 20, 21, 22, 23, 24
26	13, 18, 20, 21, 22, 23, 24, 25
27	14, 18, 21, 22, 23, 24, 25, 26

28	14, 19, 21, 23, 24, 25, 26, 27
29	15, 20, 22, 24, 25, 26, 27, 28
30	15, 20, 23, 24, 25, 26, 27, 28, 29
31	16, 21, 24, 25, 26, 27, 28, 29, 30
32	16, 22, 24, 26, 27, 28, 29, 30, 31
33	17, 22, 25, 27, 28, 29, 30, 31, 32
34	17, 23, 26, 28, 29, 30, 31, 32, 33
35	18, 24, 27, 28, 30, 31, 32, 33, 34
36	18, 24, 27, 29, 30, 31, 32, 33, 34, 35
37	19, 25, 28, 30, 31, 32, 33, 34, 35, 36
38	19, 26, 29, 31, 32, 33, 34, 35, 36, 37
39	20, 26, 30, 32, 33, 34, 35, 36, 37, 38
40	20, 27, 30, 32, 34, 35, 36, 37, 38, 39
41	21, 28, 31, 33, 35, 36, 37, 38, 39, 40
42	28, 32, 34, 35, 36, 37, 38, 39, 40, 41
43	29, 33, 35, 36, 37, 38, 39, 40, 41, 42
44	30, 33, 36, 37, 38, 39, 40, 41, 42, 43
45	30, 34, 36, 38, 39, 40, 41, 42, 43, 44
46	31, 35, 37, 39, 40, 41, 42, 43, 44, 45
47	32, 36, 38, 40, 41, 42, 43, 44, 45, 46
48	32, 36, 39, 40, 42, 43, 44, 45, 46, 47
49	33, 37, 40, 41, 42, 43, 44, 45, 46, 47, 48
50	34, 38, 40, 42, 43, 44, 45, 46, 47, 48, 49
51	34, 39, 41, 43, 44, 45, 46, 47, 48, 49, 50
52	35, 39, 42, 44, 45, 46, 47, 48, 49, 50, 51
53	36, 40, 43, 45, 46, 47, 48, 49, 50, 51, 52
54	36, 41, 44, 45, 47, 48, 49, 50, 51, 52, 53
55	37, 42, 44, 46, 48, 49, 50, 51, 52, 53, 54
56	38, 42, 45, 47, 48, 49, 50, 51, 52, 53, 54, 55

57	38, 43, 46, 48, 49, 50, 51, 52, 53, 54, 55, 56
58	39, 44, 47, 49, 50, 51, 52, 53, 54, 55, 56, 57
59	40, 45, 48, 50, 51, 52, 53, 54, 55, 56, 57, 58
60	40, 45, 48, 50, 52, 53, 54, 55, 56, 57, 58, 59
61	41, 46, 49, 51, 53, 54, 55, 56, 57, 58, 59, 60
62	42, 47, 50, 52, 54, 55, 56, 57, 58, 59, 60, 61
63	48, 51, 53, 54, 56, 57, 58, 59, 60, 61, 62
64	48, 52, 54, 55, 56, 57, 58, 59, 60, 61, 62, 63
65	49, 52, 55, 56, 57, 58, 59, 60, 61, 62, 63, 64
66	50, 53, 55, 57, 58, 59, 60, 61, 62, 63, 64, 65
67	51, 54, 56, 58, 59, 60, 61, 62, 63, 64, 65, 66
68	51, 55, 57, 59, 60, 61, 62, 63, 64, 65, 66, 67
69	52, 56, 58, 60, 61, 62, 63, 64, 65, 66, 67, 68
70	53, 56, 59, 60, 62, 63, 64, 65, 66, 67, 68, 69
71	54, 57, 60, 61, 63, 64, 65, 66, 67, 68, 69, 70
72	54, 58, 60, 62, 63, 64, 65, 66, 67, 68, 69, 70, 71
73	55, 59, 61, 63, 64, 65, 66, 67, 68, 69, 70, 71, 72
74	56, 60, 62, 64, 65, 66, 67, 68, 69, 70, 71, 72, 73
75	57, 60, 63, 65, 66, 67, 68, 69, 70, 71, 72, 73, 74
76	57, 61, 64, 66, 67, 68, 69, 70, 71, 72, 73, 74, 75
77	58, 62, 65, 66, 68, 69, 70, 71, 72, 73, 74, 75, 76
78	59, 63, 65, 67, 69, 70, 71, 72, 73, 74, 75, 76, 77
79	60, 64, 66, 68, 70, 71, 72, 73, 74, 75, 76, 77, 78
80	60, 64, 67, 69, 70, 72, 73, 74, 75, 76, 77, 78, 79
81	61, 65, 68, 70, 71, 72, 73, 74, 75, 76, 77, 78, 79, 80
82	62, 66, 69, 71, 72, 73, 74, 75, 76, 77, 78, 79, 80, 81
83	63, 67, 70, 72, 73, 74, 75, 76, 77, 78, 79, 80, 81, 82
84	68, 70, 72, 74, 75, 76, 77, 78, 79, 80, 81, 82, 83
85	68, 71, 73, 75, 76, 77, 78, 79, 80, 81, 82, 83, 84

86	69, 72, 74, 76, 77, 78, 79, 80, 81, 82, 83, 84, 85
87	70, 73, 75, 77, 78, 79, 80, 81, 82, 83, 84, 85, 86
88	71, 74, 76, 77, 79, 80, 81, 82, 83, 84, 85, 86, 87
89	72, 75, 77, 78, 80, 81, 82, 83, 84, 85, 86, 87, 88
90	72, 75, 78, 79, 80, 81, 82, 83, 84, 85, 86, 87, 88, 89
91	73, 76, 78, 80, 81, 82, 83, 84, 85, 86, 87, 88, 89, 90
92	74, 77, 79, 81, 82, 83, 84, 85, 86, 87, 88, 89, 90, 91
93	75, 78, 80, 82, 83, 84, 85, 86, 87, 88, 89, 90, 91, 92
94	76, 79, 81, 83, 84, 85, 86, 87, 88, 89, 90, 91, 92, 93
95	76, 80, 82, 84, 85, 86, 87, 88, 89, 90, 91, 92, 93, 94
96	77, 80, 83, 84, 86, 87, 88, 89, 90, 91, 92, 93, 94, 95
97	78, 81, 84, 85, 87, 88, 89, 90, 91, 92, 93, 94, 95, 96
98	79, 82, 84, 86, 88, 89, 90, 91, 92, 93, 94, 95, 96, 97
99	80, 83, 85, 87, 88, 90, 91, 92, 93, 94, 95, 96, 97, 98
100	80, 84, 86, 88, 89, 90, 91, 92, 93, 94, 95, 96, 97, 98, 99
101	81, 85, 87, 89, 90, 91, 92, 93, 94, 95, 96, 97, 98, 99, 100
102	82, 85, 88, 90, 91, 92, 93, 94, 95, 96, 97, 98, 99, 100, 101
103	83, 86, 89, 91, 92, 93, 94, 95, 96, 97, 98, 99, 100, 101, 102
104	84, 87, 90, 91, 93, 94, 95, 96, 97, 98, 99, 100, 101, 102, 103
105	88, 90, 92, 94, 95, 96, 97, 98, 99, 100, 101, 102, 103, 104
106	89, 91, 93, 95, 96, 97, 98, 99, 100, 101, 102, 103, 104, 105
107	90, 92, 94, 96, 97, 98, 99, 100, 101, 102, 103, 104, 105, 106
108	90, 93, 95, 96, 98, 99, 100, 101, 102, 103, 104, 105, 106, 107
109	91, 94, 96, 97, 99, 100, 101, 102, 103, 104, 105, 106, 107, 108
110	92, 95, 97, 98, 99, 100, 101, 102, 103, 104, 105, 106, 107, 108, 109
111	93, 96, 98, 99, 100, 101, 102, 103, 104, 105, 106, 107, 108, 109, 110
112	94, 96, 98, 100, 101, 102, 103, 104, 105, 106, 107, 108, 109, 110, 111
113	95, 97, 99, 101, 102, 103, 104, 105, 106, 107, 108, 109, 110, 111, 112
114	95, 98, 100, 102, 103, 104, 105, 106, 107, 108, 109, 110, 111, 112, 113

115	96, 99, 101, 103, 104, 105, 106, 107, 108, 109, 110, 111, 112, 113, 114
116	97, 100, 102, 104, 105, 106, 107, 108, 109, 110, 111, 112, 113, 114, 115
117	98, 101, 103, 104, 106, 107, 108, 109, 110, 111, 112, 113, 114, 115, 116
118	99, 102, 104, 105, 107, 108, 109, 110, 111, 112, 113, 114, 115, 116, 117
119	100, 102, 105, 106, 108, 109, 110, 111, 112, 113, 114, 115, 116, 117, 118
120	100, 103, 105, 107, 108, 110, 111, 112, 113, 114, 115, 116, 117, 118, 119
121	101, 104, 106, 108, 109, 110, 111, 112, 113, 114, 115, 116, 117, 118, 119, 120
122	102, 105, 107, 109, 110, 111, 112, 113, 114, 115, 116, 117, 118, 119, 120, 121
123	103, 106, 108, 110, 111, 112, 113, 114, 115, 116, 117, 118, 119, 120, 121, 122
124	104, 107, 109, 111, 112, 113, 114, 115, 116, 117, 118, 119, 120, 121, 122, 123
125	105, 108, 110, 112, 113, 114, 115, 116, 117, 118, 119, 120, 121, 122, 123, 124
126	108, 111, 112, 114, 115, 116, 117, 118, 119, 120, 121, 122, 123, 124, 125
127	109, 112, 113, 115, 116, 117, 118, 119, 120, 121, 122, 123, 124, 125, 126
128	110, 112, 114, 116, 117, 118, 119, 120, 121, 122, 123, 124, 125, 126, 127
129	111, 113, 115, 117, 118, 119, 120, 121, 122, 123, 124, 125, 126, 127, 128
130	112, 114, 116, 117, 119, 120, 121, 122, 123, 124, 125, 126, 127, 128, 129
131	113, 115, 117, 118, 120, 121, 122, 123, 124, 125, 126, 127, 128, 129, 130
132	114, 116, 118, 119, 120, 121, 122, 123, 124, 125, 126, 127, 128, 129, 130, 131
133	114, 117, 119, 120, 121, 122, 123, 124, 125, 126, 127, 128, 129, 130, 131, 132
134	115, 118, 120, 121, 122, 123, 124, 125, 126, 127, 128, 129, 130, 131, 132, 133
135	116, 119, 120, 122, 123, 124, 125, 126, 127, 128, 129, 130, 131, 132, 133, 134
136	117, 119, 121, 123, 124, 125, 126, 127, 128, 129, 130, 131, 132, 133, 134, 135
137	118, 120, 122, 124, 125, 126, 127, 128, 129, 130, 131, 132, 133, 134, 135, 136
138	119, 121, 123, 125, 126, 127, 128, 129, 130, 131, 132, 133, 134, 135, 136, 137
139	120, 122, 124, 126, 127, 128, 129, 130, 131, 132, 133, 134, 135, 136, 137, 138
140	120, 123, 125, 126, 128, 129, 130, 131, 132, 133, 134, 135, 136, 137, 138, 139
141	121, 124, 126, 127, 129, 130, 131, 132, 133, 134, 135, 136, 137, 138, 139, 140
142	122, 125, 127, 128, 130, 131, 132, 133, 134, 135, 136, 137, 138, 139, 140, 141
143	123, 126, 128, 129, 130, 132, 133, 134, 135, 136, 137, 138, 139, 140, 141, 142

144	124, 126, 128, 130, 131, 132, 133, 134, 135, 136, 137, 138, 139, 140, 141, 142, 143
145	125, 127, 129, 131, 132, 133, 134, 135, 136, 137, 138, 139, 140, 141, 142, 143, 144
146	126, 128, 130, 132, 133, 134, 135, 136, 137, 138, 139, 140, 141, 142, 143, 144, 145
147	129, 131, 133, 134, 135, 136, 137, 138, 139, 140, 141, 142, 143, 144, 145, 146
148	130, 132, 134, 135, 136, 137, 138, 139, 140, 141, 142, 143, 144, 145, 146, 147
149	131, 133, 135, 136, 137, 138, 139, 140, 141, 142, 143, 144, 145, 146, 147, 148
150	132, 134, 135, 137, 138, 139, 140, 141, 142, 143, 144, 145, 146, 147, 148, 149
151	133, 135, 136, 138, 139, 140, 141, 142, 143, 144, 145, 146, 147, 148, 149, 150
152	133, 136, 137, 139, 140, 141, 142, 143, 144, 145, 146, 147, 148, 149, 150, 151
153	134, 136, 138, 140, 141, 142, 143, 144, 145, 146, 147, 148, 149, 150, 151, 152
154	135, 137, 139, 140, 142, 143, 144, 145, 146, 147, 148, 149, 150, 151, 152, 153
155	136, 138, 140, 141, 143, 144, 145, 146, 147, 148, 149, 150, 151, 152, 153, 154
156	137, 139, 141, 142, 143, 144, 145, 146, 147, 148, 149, 150, 151, 152, 153, 154, 155
157	138, 140, 142, 143, 144, 145, 146, 147, 148, 149, 150, 151, 152, 153, 154, 155, 156
158	139, 141, 143, 144, 145, 146, 147, 148, 149, 150, 151, 152, 153, 154, 155, 156, 157
159	140, 142, 144, 145, 146, 147, 148, 149, 150, 151, 152, 153, 154, 155, 156, 157, 158
160	140, 143, 144, 146, 147, 148, 149, 150, 151, 152, 153, 154, 155, 156, 157, 158, 159
161	141, 144, 145, 147, 148, 149, 150, 151, 152, 153, 154, 155, 156, 157, 158, 159, 160
162	142, 144, 146, 148, 149, 150, 151, 152, 153, 154, 155, 156, 157, 158, 159, 160, 161
163	143, 145, 147, 149, 150, 151, 152, 153, 154, 155, 156, 157, 158, 159, 160, 161, 162
164	144, 146, 148, 150, 151, 152, 153, 154, 155, 156, 157, 158, 159, 160, 161, 162, 163
165	145, 147, 149, 150, 152, 153, 154, 155, 156, 157, 158, 159, 160, 161, 162, 163, 164
166	146, 148, 150, 151, 153, 154, 155, 156, 157, 158, 159, 160, 161, 162, 163, 164, 165
167	147, 149, 151, 152, 154, 155, 156, 157, 158, 159, 160, 161, 162, 163, 164, 165, 166
168	150, 152, 153, 154, 156, 157, 158, 159, 160, 161, 162, 163, 164, 165, 166, 167
169	151, 153, 154, 155, 156, 157, 158, 159, 160, 161, 162, 163, 164, 165, 166, 167, 168
170	152, 153, 155, 156, 157, 158, 159, 160, 161, 162, 163, 164, 165, 166, 167, 168, 169
171	152, 154, 156, 157, 158, 159, 160, 161, 162, 163, 164, 165, 166, 167, 168, 169, 170
172	153, 155, 157, 158, 159, 160, 161, 162, 163, 164, 165, 166, 167, 168, 169, 170, 171

173	154, 156, 158, 159, 160, 161, 162, 163, 164, 165, 166, 167, 168, 169, 170, 171, 172
174	155, 157, 159, 160, 161, 162, 163, 164, 165, 166, 167, 168, 169, 170, 171, 172, 173
175	156, 158, 160, 161, 162, 163, 164, 165, 166, 167, 168, 169, 170, 171, 172, 173, 174
176	157, 159, 160, 162, 163, 164, 165, 166, 167, 168, 169, 170, 171, 172, 173, 174, 175
177	158, 160, 161, 163, 164, 165, 166, 167, 168, 169, 170, 171, 172, 173, 174, 175, 176
178	159, 161, 162, 164, 165, 166, 167, 168, 169, 170, 171, 172, 173, 174, 175, 176, 177
179	160, 162, 163, 165, 166, 167, 168, 169, 170, 171, 172, 173, 174, 175, 176, 177, 178
180	160, 162, 164, 165, 167, 168, 169, 170, 171, 172, 173, 174, 175, 176, 177, 178, 179
181	161, 163, 165, 166, 168, 169, 170, 171, 172, 173, 174, 175, 176, 177, 178, 179, 180
182	162, 164, 166, 167, 168, 169, 170, 171, 172, 173, 174, 175, 176, 177, 178, 179, 180, 181
183	163, 165, 167, 168, 169, 170, 171, 172, 173, 174, 175, 176, 177, 178, 179, 180, 181, 182
184	164, 166, 168, 169, 170, 171, 172, 173, 174, 175, 176, 177, 178, 179, 180, 181, 182, 183
185	165, 167, 169, 170, 171, 172, 173, 174, 175, 176, 177, 178, 179, 180, 181, 182, 183, 184
186	166, 168, 170, 171, 172, 173, 174, 175, 176, 177, 178, 179, 180, 181, 182, 183, 184, 185
187	167, 169, 170, 172, 173, 174, 175, 176, 177, 178, 179, 180, 181, 182, 183, 184, 185, 186
188	168, 170, 171, 173, 174, 175, 176, 177, 178, 179, 180, 181, 182, 183, 184, 185, 186, 187
189	171, 172, 174, 175, 176, 177, 178, 179, 180, 181, 182, 183, 184, 185, 186, 187, 188
190	171, 173, 175, 176, 177, 178, 179, 180, 181, 182, 183, 184, 185, 186, 187, 188, 189
191	172, 174, 176, 177, 178, 179, 180, 181, 182, 183, 184, 185, 186, 187, 188, 189, 190
192	173, 175, 176, 178, 179, 180, 181, 182, 183, 184, 185, 186, 187, 188, 189, 190, 191
193	174, 176, 177, 179, 180, 181, 182, 183, 184, 185, 186, 187, 188, 189, 190, 191, 192
194	175, 177, 178, 180, 181, 182, 183, 184, 185, 186, 187, 188, 189, 190, 191, 192, 193
195	176, 178, 179, 180, 182, 183, 184, 185, 186, 187, 188, 189, 190, 191, 192, 193, 194
196	177, 179, 180, 181, 182, 183, 184, 185, 186, 187, 188, 189, 190, 191, 192, 193, 194, 195
197	178, 180, 181, 182, 183, 184, 185, 186, 187, 188, 189, 190, 191, 192, 193, 194, 195, 196
198	179, 180, 182, 183, 184, 185, 186, 187, 188, 189, 190, 191, 192, 193, 194, 195, 196, 197
199	180, 181, 183, 184, 185, 186, 187, 188, 189, 190, 191, 192, 193, 194, 195, 196, 197, 198
200	180, 182, 184, 185, 186, 187, 188, 189, 190, 191, 192, 193, 194, 195, 196, 197, 198, 199
201	181, 183, 185, 186, 187, 188, 189, 190, 191, 192, 193, 194, 195, 196, 197, 198, 199, 200

202	182, 184, 186, 187, 188, 189, 190, 191, 192, 193, 194, 195, 196, 197, 198, 199, 200, 201
203	183, 185, 187, 188, 189, 190, 191, 192, 193, 194, 195, 196, 197, 198, 199, 200, 201, 202
204	184, 186, 187, 189, 190, 191, 192, 193, 194, 195, 196, 197, 198, 199, 200, 201, 202, 203
205	185, 187, 188, 190, 191, 192, 193, 194, 195, 196, 197, 198, 199, 200, 201, 202, 203, 204
206	186, 188, 189, 191, 192, 193, 194, 195, 196, 197, 198, 199, 200, 201, 202, 203, 204, 205
207	187, 189, 190, 192, 193, 194, 195, 196, 197, 198, 199, 200, 201, 202, 203, 204, 205, 206
208	188, 190, 191, 192, 194, 195, 196, 197, 198, 199, 200, 201, 202, 203, 204, 205, 206, 207
209	189, 190, 192, 193, 195, 196, 197, 198, 199, 200, 201, 202, 203, 204, 205, 206, 207, 208
210	191, 193, 194, 195, 196, 197, 198, 199, 200, 201, 202, 203, 204, 205, 206, 207, 208, 209
211	192, 194, 195, 196, 197, 198, 199, 200, 201, 202, 203, 204, 205, 206, 207, 208, 209, 210
212	193, 195, 196, 197, 198, 199, 200, 201, 202, 203, 204, 205, 206, 207, 208, 209, 210, 211
213	194, 196, 197, 198, 199, 200, 201, 202, 203, 204, 205, 206, 207, 208, 209, 210, 211, 212
214	195, 197, 198, 199, 200, 201, 202, 203, 204, 205, 206, 207, 208, 209, 210, 211, 212, 213
215	196, 198, 199, 200, 201, 202, 203, 204, 205, 206, 207, 208, 209, 210, 211, 212, 213, 214
216	197, 198, 200, 201, 202, 203, 204, 205, 206, 207, 208, 209, 210, 211, 212, 213, 214, 215
217	198, 199, 201, 202, 203, 204, 205, 206, 207, 208, 209, 210, 211, 212, 213, 214, 215, 216
218	199, 200, 202, 203, 204, 205, 206, 207, 208, 209, 210, 211, 212, 213, 214, 215, 216, 217
219	200, 201* , 203, 204, 205, 206, 207, 208, 209, 210, 211, 212, 213, 214, 215, 216, 217, 218
220	200, 202, 204, 205, 206, 207, 208, 209, 210, 211, 212, 213, 214, 215, 216, 217, 218, 219
221	201, 203, 204, 206, 207, 208, 209, 210, 211, 212, 213, 214, 215, 216, 217, 218, 219, 220
222	202, 204, 205, 207, 208, 209, 210, 211, 212, 213, 214, 215, 216, 217, 218, 219, 220, 221
223	203, 205, 206, 208, 209, 210, 211, 212, 213, 214, 215, 216, 217, 218, 219, 220, 221, 222
224	204, 206, 207, 208, 210, 211, 212, 213, 214, 215, 216, 217, 218, 219, 220, 221, 222, 223
225	205, 207, 208, 209, 210, 211, 212, 213, 214, 215, 216, 217, 218, 219, 220, 221, 222, 223, 224
226	206, 208, 209, 210, 211, 212, 213, 214, 215, 216, 217, 218, 219, 220, 221, 222, 223, 224, 225
227	207, 209, 210, 211, 212, 213, 214, 215, 216, 217, 218, 219, 220, 221, 222, 223, 224, 225, 226
228	208, 209, 211, 212, 213, 214, 215, 216, 217, 218, 219, 220, 221, 222, 223, 224, 225, 226, 227

229	209, 210, 212, 213, 214, 215, 216, 217, 218, 219, 220, 221, 222, 223, 224, 225, 226, 227, 228
230	210, 211, 213, 214, 215, 216, 217, 218, 219, 220, 221, 222, 223, 224, 225, 226, 227, 228, 229
231	212, 214, 215, 216, 217, 218, 219, 220, 221, 222, 223, 224, 225, 226, 227, 228, 229, 230
232	213, 215, 216, 217, 218, 219, 220, 221, 222, 223, 224, 225, 226, 227, 228, 229, 230, 231
233	214, 216, 217, 218, 219, 220, 221, 222, 223, 224, 225, 226, 227, 228, 229, 230, 231, 232
234	215, 216, 218, 219, 220, 221, 222, 223, 224, 225, 226, 227, 228, 229, 230, 231, 232, 233
235	216, 217, 219, 220, 221, 222, 223, 224, 225, 226, 227, 228, 229, 230, 231, 232, 233, 234
236	217, 218, 220, 221, 222, 223, 224, 225, 226, 227, 228, 229, 230, 231, 232, 233, 234, 235
237	218, 219, 221, 222, 223, 224, 225, 226, 227, 228, 229, 230, 231, 232, 233, 234, 235, 236
238	219, 220, 221, 223, 224, 225, 226, 227, 228, 229, 230, 231, 232, 233, 234, 235, 236, 237
239	220, 221, 222, 224, 225, 226, 227, 228, 229, 230, 231, 232, 233, 234, 235, 236, 237, 238
240	220, 222, 223, 224, 225, 226, 227, 228, 229, 230, 231, 232, 233, 234, 235, 236, 237, 238, 239
241	221, 223, 224, 225, 226, 227, 228, 229, 230, 231, 232, 233, 234, 235, 236, 237, 238, 239, 240
242	222, 224, 225, 226, 227, 228, 229, 230, 231, 232, 233, 234, 235, 236, 237, 238, 239, 240, 241
243	223, 225, 226, 227, 228, 229, 230, 231, 232, 233, 234, 235, 236, 237, 238, 239, 240, 241, 242
244	224, 226, 227, 228, 229, 230, 231, 232, 233, 234, 235, 236, 237, 238, 239, 240, 241, 242, 243
245	225, 227, 228, 229, 230, 231, 232, 233, 234, 235, 236, 237, 238, 239, 240, 241, 242, 243, 244
246	226, 228, 229, 230, 231, 232, 233, 234, 235, 236, 237, 238, 239, 240, 241, 242, 243, 244, 245
247	227, 228, 230, 231, 232, 233, 234, 235, 236, 237, 238, 239, 240, 241, 242, 243, 244, 245, 246
248	228, 229, 231, 232, 233, 234, 235, 236, 237, 238, 239, 240, 241, 242, 243, 244, 245, 246, 247
249	229, 230, 232, 233, 234, 235, 236, 237, 238, 239, 240, 241, 242, 243, 244, 245, 246, 247, 248
250	230, 231, 233, 234, 235, 236, 237, 238, 239, 240, 241, 242, 243, 244, 245, 246, 247, 248, 249

251	231, 232, 234, 235, 236, 237, 238, 239, 240, 241, 242, 243, 244, 245, 246, 247, 248, 249, 250
252	233, 234, 236, 237, 238, 239, 240, 241, 242, 243, 244, 245, 246, 247, 248, 249, 250, 251
253	234, 235, 237, 238, 239, 240, 241, 242, 243, 244, 245, 246, 247, 248, 249, 250, 251, 252
254	235, 236, 238, 239, 240, 241, 242, 243, 244, 245, 246, 247, 248, 249, 250, 251, 252, 253
255	236, 237, 238, 240, 241, 242, 243, 244, 245, 246, 247, 248, 249, 250, 251, 252, 253, 254

*** Note: T1 Framing not supported (IBS, Drop & Insert).**



Glossary

A	
A	Ampere
AC	Alternating Current
ADC	Analog to Digital Converter
AGC	Automatic Gain Control
AIS	Alarm Indication System. A signal comprised of all binary 1s.
AMSL	Above Mean Sea Level
ANSI	American National Standards Institute
ASCII	American Standard Code for Information Interchange
ASIC	Application Specific Integrated Circuit
ATE	Automatic Test Equipment
B	
BER	Bit Error Rate
BERT	Bit Error Rate Test
Bit/BIT	Binary Digit or Built-In Test
BITE	Built-In Test Equipment
bps	Bits Per Second
BPSK	Binary Phase Shift Keying
Byte	8 Binary Digits
C	
C	Celsius
CATS	Computer Aided Test Software
CA/xxxx	Cable Assembly
CD-ROM	Compact Disk – Read Only Memory
CLK	Clock
cm	Centimeter
COM	Common
CPU	Central Processing Unit
CRC	Cyclic Redundancy Check. A system of error checking performed at the transmitting and receiving stations.
CW	Continuous Wave
C/N	Carrier to Noise Ratio

D	
DAC	Digital to Analog Converter
dB	Decibels
dBc	Decibels Referred to Carrier
dBm	Decibels Referred to 1.0 milliwatt
DC	Direct Current
DCE	Data Communications Equipment
Demod	Demodulator or Demodulated
DPLL	Digital Phase Locked Loop
DTE	Data Terminal Equipment
DVB	Digital Video Broadcast
D&I	Drop and Insert
E	
E_b/N_0	Ratio of Energy per bit to Noise Power Density in a 1 Hz Bandwidth.
EEPROM	Electrically Erasable Programmable Read Only Memory
EIA	Electronic Industries Association
EMI	Electromagnetic Interference
ESC	Engineering Service Circuits
ET	Earth Terminal
F	
F	Fahrenheit
FAS	Frame Acquisition Sync. A repeating series bits which allow acquisition of a frame.
FCC	Federal Communications Commission
FEC	Forward Error Correction
FIFO	First In, First Out
FPGA	Field Programmable Gate Arrays
FW	Firmware
G	
g	Force of Gravity
GHz	Gigahertz
GND	Ground

H	
HSSI	High Speed Serial Interface
HW	Hardware
Hz	Hertz (Unit of Frequency)
I	
IBS	Intelsat Business Services
IDR	Intermediate Data Rate
I/O	Input/Output
IEEE	International Electrical and Electronic Engineers
IESS	INTELSAT Earth Station Standards
IF	Intermediate Frequency
INTELSAT	International Telecommunication Satellite Organization
ISO	International Standards Organization
J	
J	Joule
K	
Kbps	Kilobits per Second
Kbps	Kilobytes per Second
kg	Kilogram
kHz	Kilohertz
Ksps	Kilosymbols per Second
L	
LCD	Liquid Crystal Display
LED	Light Emitting Diode
LO	Local Oscillator

M	
mA	Milliampere
Mbps	Megabits per Second
MFAS	Multi-Frame Acquisition Sync. See FAS.
MHz	Megahertz
MIB	Management Information Base
Mod	Modulator or Modulated
ms	Millisecond
M&C	Monitor and Control
N	
NC	Normally Closed
NO	Normally Open
ns	Nanoseconds
NVRAM	Non-Volatile Random Access Memory
N/C	No Connection or Not Connected
O	
OQPSK	Offset Quadrature Phase Shift Keying
P	
PC	Personal Computer
PLL	Phase Locked Loop
ppb	Parts per Billion
ppm	Parts per Million
P/N	Part Number
Q	
QAM	Quadrature Amplitude Modulation
QPSK	Quadrature Phase Shift Keying

R	
RAM	Random Access Memory
RF	Radio Frequency
ROM	Read Only Memory
rms	Root Mean Square
RU	Rack Unit. 1 RU = 1.75"
Rx	Receive (Receiver)
RxD	Receive Data
R-S	Reed-Solomon Coding. Reed-Solomon codes are block-based error correcting codes with a wide range of applications in digital communications and storage.
S	
SEQ	Sequential
SYNC	Synchronize
T	
TBD	To Be Designed or To Be Determined
TM	Technical Manual
TPC	Turbo Product Codes
TRE	Trellis
Tx	Transmit (Transmitter)
TxD	Transmit Data
U	
UART	Universal Asynchronous Receiver/Transmitter
UUT	Unit Under Test
V	
V	Volts
VAC	Volts, Alternating Current
VCO	Voltage Controlled Oscillator
VDC	Volts, Direct Current
VIT	Viterbi Decoding

W X Y Z	
W	Watt
Misc.	
μ s	Microsecond
Ω	Ohms
16QAM	16 Quadrature Amplitude Modulation
8PSK	8 Phase Shift Keying