

MITEL

5624 Wireless Handset



Mitel WiFi System (EMEA)
User Guide

NOTICE

The information contained in this document is believed to be accurate in all respects but is not warranted by Mitel Networks™ Corporation (MITEL®). The information is subject to change without notice and should not be construed in any way as a commitment by Mitel or any of its affiliates or subsidiaries. Mitel and its affiliates and subsidiaries assume no responsibility for any errors or omissions in this document. Revisions of this document or new editions of it may be issued to incorporate such changes.

No part of this document can be reproduced or transmitted in any form or by any means - electronic or mechanical - for any purpose without written permission from Mitel Networks Corporation.

Trademarks

Mitel is registered trademark of Mitel Networks Corporation.

Other product names mentioned in this document may be trademarks of their respective companies and are hereby acknowledged.

Mitel WiFi System (EMEA)
Mitel 5624 Wireless Handset User Guide
February 2012

®,™ Trademark of Mitel Networks Corporation
© Copyright 2012, Mitel Networks Corporation
All rights reserved

About Your Phone	1
Elements of the Handset	2
Features and Functions	3
Chargers	4
Contacting Emergency Services	5
Tips for your Comfort and Safety	5
Frequency Range	5
Exposure to Radio Frequency Signals	6
Environmental Requirements	6
Chemical Resistance	7
Icons and Text in the Display	7
Keys and Buttons	11
Off-hook Key	11
On-hook and On/Off Keys	11
Navigation/Confirmation Key	11
Sound Off Key	11
Mute and PTT Button	11
Key Lock and Upper/Lower Case Key	11
Soft Keys	11
Hot Keys	12
Multifunction Button	12
Volume Button	12
Alphanumeric Keys	12
Headsets	13
Customizing Your Phone	14
Switch the Handset On	14
Switch the Handset Off	14
Log a Shared Phone On/Off	14
Turn On/Off the Audible Signal	15
Lock/Unlock the Keypad	15
Lock/Unlock the Handset	16
Making and Answering Calls	17
Call List	17
Make a Call	17
Pre-Dial	17
Dial Using a Pre-programmed Hot Key, Soft Key or Multifunction Button	17
Dial a Number from the Call List	17
Dial the Sender of a Message	18

- Dial a Number from the Local Phonebook18
- Dial a Name from the Central Phonebook18
- Dial a Number from the Company Phonebook18
- Answer a Call19
 - Answer a Call19
 - End a Call19
- During a Call19
 - Adjust the Volume during a Call20
 - Open Contacts during a Call20
 - Turn on/off the Microphone during a Call20
 - Lock/Unlock the Keypad during a Call21
 - Start a New Call during a Conversation21
- Call Handling 22
 - Hold22
 - Transfer to a New Call (Unsupervised)22
 - Supervised Transfer22
 - Conference23
 - Answer Call Waiting23
 - Call Park24
- Advanced Features 25
 - Call Forward25
 - Call Pickup26
 - Do Not Disturb26
 - Direct Page26
 - Group Page26
- Messaging 27
 - Message List27
 - Receive a Message27
 - Incoming Message for the 5624 Services License27
 - Incoming Message for all 5624s except for the 5624 Services License27
 - Read a Stored Message27
 - Reply to a Message28
 - Delete a Message28
 - Forward a Message28
 - Call the Sender of the Message28
 - Call a Number Included in a Message29
 - Save a Number29
 - Write and Send a Message29

Open a Sent Message	30
Send a Message to Another Destination	30
Receive a Message with Request for Answer	30
Accept/Reject the Message	30
Message Queuing and Message Priority	31
Interactive Messaging	32
Colored Messaging	33
Mobile Data	33
Send Mobile Data	33
Send Mobile Data with a Prefix	34
Voice Mail	34
Receive a Voice Mail	34
Check the Voice Mail Inbox	34
One Key Voice Mail Access	34
Alarm Operation	35
Push-button Alarm	35
Acoustic Location Signal	35
Test Alarm	35
Alarm with Location Information	35
Alarm with Data	36
Automatic Call after Alarm	36
Menu Tree	37
Customizing the Menu Tree	37
Calls	38
Contacts	39
Profile	40
Messaging	41
Services	42
Short cuts	
Connections	43
Settings	44
In Call	46
Additional In Call Functions	46
Navigate the Menu	47
Connections Menu	47
Headsets	47
In Charger	48

- Calls Menu 48
 - Call List 48
 - Missed Calls 49
 - Push to Talk 50
- Short Cuts Menu 52
 - Define Soft Keys 52
 - Define Hot Keys 53
 - Define Navigation Keys 53
 - Define the Multifunction or Alarm Button 54
- Services Menu 54
 - Add a Service 54
 - Edit a Service 55
 - Delete a Service 55
- Messaging 55
 - Inbox 55
 - Write New Messages 57
 - Unsent Messages 57
 - Sent Messages 57
- Profiles Menu 58
- Contacts Menu 59
 - Call a Contact 59
 - Add a Contact 59
 - Edit a Contact 60
 - Delete a Contact 60
 - Central Phonebook 60
- Settings Menu 61
 - Sound and Alert Settings 61
 - Phone Lock Settings 62
 - Display Settings 64
 - Time and Date Settings 64
 - Answering 65
 - Change Text Size for Messages 66
 - Change the Menu Language 66
 - Change Owner ID 66
- Troubleshooting 67
- Operation Notice 70
 - Accessibility and Voice Quality 70
- Maintenance 71
 - Maintenance of Batteries 71

Battery Warnings	71
Charge the Battery	71
Charge Spare Batteries	71
Replace the Battery	71
Easy Replacement of Handset	72
Before Starting the Easy Replacement Procedure	72
Easy Replacement Procedure	73
Attach the Hinge-type Clip	75
Attach the Swivel-type Clip	75
Attach a Cover without a Clip	76
Related Documents	76
Index	77

About Your Phone

This document describes the features and settings of the Mitel 5624 (WiFi) handset. This feature-rich handset has a color display, telephony, and messaging. It is designed to be used in demanding environments, such as hospitals, and in office environments.

The 5624 handset is suitable for users who need to readily be reached and/or have a need for mobile voice and messaging features. It is ideal for applications where the user needs either one way messaging or needs to interact with other users. The color display enhances and simplifies the use of the handset.

The 5624 Standard Handset can be upgraded with Services and Personal Alarm with messaging functions.

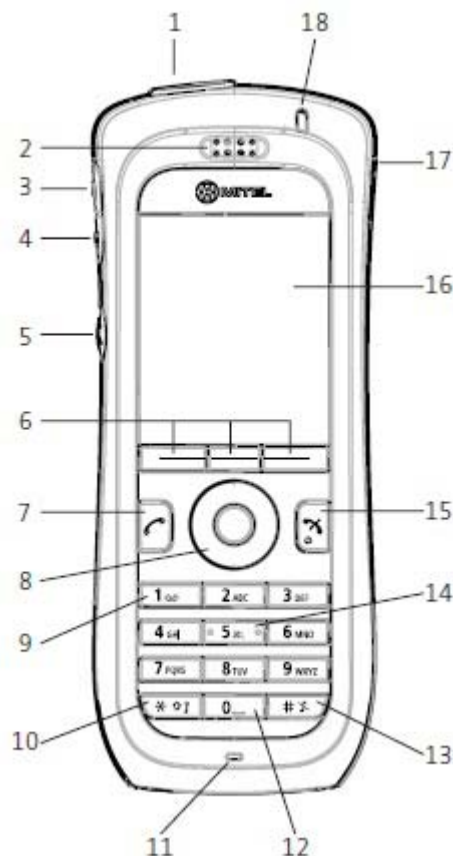

Figure 1: 5624 Handset

Caution: The handset/headset must be fully charged before starting regular use.

Elements of the Handset

1	Multi-function button This button can be used as a short cut to functions: long or double press modes. In the Protector, the button is used for sending alarms or dialing pre-defined numbers. See Define the Multifunction or Alarm Button on page 54 and Push-button Alarm on page 35.
2	Earpiece speaker
3	Volume button (up) To increase the speaker earpiece, headset, and loudspeaker volume
4	Volume button (down) To decrease the speaker earpiece, headset, and loudspeaker volume
5	Mute and PTT button To turn on/off audible signals in standby mode, or silence the ring signal at incoming call. During a call, a long press on the button changes between microphone on/off, same as Sound off key. During a PTT group call, the microphone is open as long as the button is depressed.
6	Soft keys The 3 soft keys can be pre-programmed or used with GUI
7	Call key To answer a call, to pre-dial a number, and a short cut to the Call list.
8	Four-way navigation key Navigation key with Left, Right, Up, Down with Confirmation (in the middle). You can program these keys for short cuts, except the middle key.
9	Voice mail access* (System-dependent feature) Quick access to the handset's Voice mail by long press
10	Key lock and Upper/Lower case Combined key lock and Upper/Lower Case This key locks the keypad in combination with the "Lock" soft key.
11	Microphone
12	Space Used to add space between text and as a multi-purpose connector
13	Sound off key To turn on/off audible signals in idle mode, silencing the ring signal at incoming call, and to turn on/off the microphone during a call.
14	Tactile indicators There are two tactile indicators to indicate the centre of the key pad
15	On-hook and On/Off key Combined button: to end a call, to return to standby mode, and to switch the handset on/off by long press
16	Color display The full graphic type display is 128 pixels wide and 160 pixels high. The display has multiple colors and backlighting.
17	Headset connector The headset connector is used to connect a headset. The headset connector cover protects it from dust.
18	LED Indicates incoming call, messaging, low battery, and charging.

Features and Functions

IMPORTANT:The handset may retain small magnetic objects around the mouth cap or ear cap region.

Case

The plastic cover parts are made of durable PC/ABS material.

The Mitel WiFi 5624 Handset has the enclosure protection IP44 and it also fulfills IEC 60068-2-32, procedure 1, which makes it drop proof from 1 meter onto concrete. Ascom approves 12 drops from 1.5 metre.

Antenna

The antenna is integrated inside the handset.

Loudspeaker

The handset has a separate loudspeaker for the Loudspeaking function. It is placed on the back side of the handset.

Microphone

The microphone is placed on the front bottom side of the handset.

Clip

There are two different belt clip options for the handset: a hinge-type clip (standard), and a swivel-type clip. Use the clip to attach the handset to a pocket or belt. You can use the handset without a clip on. See the *Mitel 5624 Wireless Handset Configuration Guide*.

Battery

The battery is a rechargeable Li-pol battery, placed under a battery cover. See “Replace the Battery” on page 71.

The battery is fully charged within 2.5 hours. See “Charge the Battery” on page 71.

The battery can be charged separately with a special battery charger. See “Charge Spare Batteries” on page 71.

Chargers

Desktop Charger



Figure 2: Desktop Charger

You use the DC3 desktop charger to charge the handset and the Mitel 5624 Desktop Programmer to download new software and synchronize parameters. The units look the same except that the Desktop Programmer has an USB connection. The handset is fully operational while placed in the charger.

The charger is delivered with a plug-in power supply and is connected into an ordinary wall socket.



Note: Use the charger only within the temperature range of +5° C – +40° C.

Caution: Use only the provided power supply.

Rack Charger

The CR3-DAA is a new version of the CR3 Charging Rack:

- The CR3-DAA Charging Rack charges six 5603/5604/5624 handsets simultaneously and is used for charging and configuration.
- The CR3-DBAC Charging Rack charges six 5603/5604/5607/5624 handsets simultaneously and is used for charging only.

For more information, see the *5603/5604/5607/5624 Rack Charger Installation and Operation Guide*.

Battery Pack Charger

The battery pack charger can charge up to six spare batteries. For more information, see the *5603/5604/5607/5624 Rack Charger Installation and Operation Guide*.

Contacting Emergency Services

This handset, like any wireless phone, communicates using radio signals. As with any wireless phone, you may not be able to establish a connection under all conditions; therefore, you should not rely solely on a wireless telephone for essential, emergency communication. The key lock feature disables the handset keypad and prevents the accidental dialing of numbers that may result in nuisance calls. It also prevents accidental calls to emergency services numbers like 911, 999, or 112.

To disable the key lock feature, press the ***** key and then press the **Yes** softkey.

Currently, mobile IP phones do not support Enhanced 911 (E911) operation. If emergency services are required, it is necessary to keep the system administrator and location database up-to-date.

Tips for your Comfort and Safety

Don't Cradle the Handset!

Prolonged use of the handset can lead to neck, shoulder, or back discomfort, especially if you cradle the handset between your ear and shoulder. If you use your phone a lot, you may find it more comfortable to use a headset. See the section on headset usage elsewhere in this guide for more information.

Protect your Hearing

Your phone has a control for adjusting the volume of the handset receiver or headset. Because continuous exposure to loud sounds can contribute to hearing loss, keep the volume at a moderate level.

Frequency Range

The handset is a radio transmitter and receiver. When it is on, it receives and sends out radio frequency (RF) energy. The handset operates on different frequency ranges depending on market and employs commonly used modulation techniques:

EU	b/g: 2400–2483.5 MHz (Ch 1–13) and a: 5150–5350 MHz (Ch 36, 40, 44, 48, 52, 56, 60, 64), 5470–5710 MHz (Ch 100, 104, 108, 112, 116, 120, 124, 128, 132, 136, 140)
USA/CAN	b/g: 2400–2483.5 MHz (Ch 1–11) and a: 5150–5350 MHz (Ch 36, 40, 44, 48, 52, 56, 60, 64), 5470–5710 MHz (Ch 100, 104, 108, 112, 116, 120, 124, 128, 132, 136, 140), 5725–5875 (Ch 149, 153, 157, 161, 165)



Note: DFS channels should be avoided as Mobile devices are prevented from using these channels without a period of listening to ensure radar avoidance. This listening time causes delays in the ability to communicate with the WiFi infrastructure and therefore are not suitable for voice. Instead configure the PP to use UNII-1 channels.

Exposure to Radio Frequency Signals

This equipment complies with FCC radiation exposure limits set forth for an uncontrolled environment. This device complies with FCC SAR limit of 1.6 W/kg. The maximum SAR value measured when used at the ear is 1.02 W/kg. The telephone has also been tested when worn on the body using belt clip. The maximum measured SAR value in this configuration is 0.689 W/kg. This device must not be co-located or operating in conjunction with any other antenna or transmitter.

Use of non-Mitel approved accessories may violate the FCC and IC guidelines for RF exposure and should be avoided.

Environmental Requirements

5624 Handset

- Only use the handset in temperatures between -10° C to +55° C (14° F to 131° F).
- Avoid exposing the handset for direct sunlight or close to other heat sources.
- Connect AC (power supply) to the desktop battery charger only to designated power sources as indicated on the product.
- Never change the AC cord or plug. If the plug does not fit into the outlet, have a proper outlet installed by a qualified electrician. Improper connection increases the risk of electric shock.
- Avoid volume levels that may be harmful to your hearing. Exposure to excessive sound pressure from a handset's earpiece or headset may cause permanently hearing loss.
- Do not expose the handset to open flame.
- Keep the handset away from excessive heat and moisture.
- Avoid sudden temperature changes to prevent condensation in the handset. It is recommended to put the handset into an air tight plastic bag until the temperature is adjusted, for example, when entering or leaving a cold/heated building on a warm/cold day.
- Protect your handset from aggressive liquids and vapors.
- If the handset has been exposed for water or condensation, remove the battery immediately and let it dry completely before re-inserting the battery.
- The handset may retain small metal objects around the mouth cap or ear cap region.
- Keep the handset away from strong electromagnetic fields.
- Do not place a cold handset in a charger.

Chemical Resistance

The alpha and numeric characters printed on the exterior of the handset have been tested and found resistant to chipping, fading or wearing off when the handset is treated with common cleaners and disinfectants or perspiration. The following chemicals have shown no harmful effect:

- 3% Hydrochloric Acid
- M-alcohol (70% Methylated Ethanol)
- 60% Chlorhexidin 0.5mg/ml

Acetone can be damaging to the plastic casing of the handset and should not be used.

Icons and Text in the Display

All functions and settings available to the user are shown as icons and text in the display. The display normally displays date and time, the Owner ID and handset number. The Owner ID can manually be set by the user.

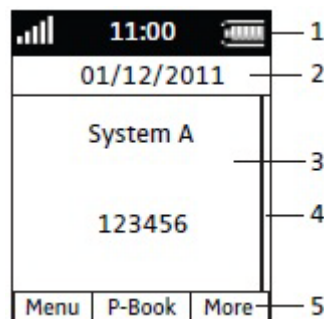

Figure 3: Display Configuration in Standby Mode

The Status bar (1) is used for icons which give the user information about signal strength, missed calls, new messages, phone lock, key lock, sound off, time and battery status. This row is always visible in all screens.

















The Header bar (2) displays the current date, headset connection, and system connection. During call it also displays microphone on and loudspeaker on.



















The Active area (3) is used for information such as the name of the system to which the handset is connected. A user identity provided from the system and/or an Owner ID can also be displayed if configured in the Settings menu. This is also the area for dialog window text, for example "missed calls", or to confirm an action.





The Scroll bar (4) is placed to the right of the "Active area". It becomes visible when a menu screen has more than six menus, or if the complete text in a message cannot be displayed on the screen simultaneously.

The Soft key bar (5) is used for soft keys which can be used as short cuts for functions in the handset. See the *Mitel 5624 Wireless Handset Configuration Guide*.

Icons

	"Signal strength" icon is visible in the upper left corner. The staples shown in display depend on the signal strength.
	"Full battery" icon appears in upper right corner
	"Low battery warning" icon is shown when the battery has 10% or less remaining capacity
	"Empty battery warning" icon flashes when the battery has 5% or less remaining capacity
	"Sound off" icon appears when the Sound off key or Mute button is pressed
	"Microphone off" icon indicates a silenced microphone. It appears after a long press on the Sound off key, or Mute button during a call During a PTT call, the microphone is silenced when the PTT button is released
	"Loudspeaking" icon appears in the soft key bar during a call. Pressing this icon turns on the loudspeaker.
	"Loudspeaking off" icon appears after the soft key for the Loudspeaking icon is pressed. Pressing this icon turns off the loudspeaker.
	"Headset connected" icon indicates that a corded headset is connected to the handset.
	"New message" icon or "Interactive message" icon indicates that a new text message(s) has arrived. The icon remains in the status bar until all new messages in the inbox are read.
	"New Message with Request for answer" icon in front of a message indicates the message must be acknowledged or rejected.
	"New Message, High priority" icon included with New message icon indicates message is of high priority
	"New Message, Alarm priority" icon included with New message icon indicates the alarm priority of a message.
	Voice mail message" icon appears in the message box when voice mails are received. The icon remains until you listen to your the voice mail.
	"Read message" icon or "Read Interactive message" icon in front of a message shows that the message was already read.
	"Sent message" icon.
	"New colored message" icon indicates that a new colored text message(s) has arrived. The messages can be labeled with different colors.

	"Read colored message" icon indicates that a colored text message(s) has been read. The messages can be labeled with different colors.
	"Profile active" icon.
	"Missed call" icon is added to all missed calls in the call list.
	"Incoming call" icon is added to all answered calls in the call list.
	"Outgoing call" icon is added to all outgoing calls in the call list.
	"Missed call" icon indicates missed calls in the status bar.
	"Connected call" icon indicates an ongoing call.
	"Call on hold" icon indicates a paused call
	"Call diverted" icon indicates that all calls are diverted to another 5624 Handset.
	"To contacts" icon indicates a soft key function that opens the contact list.
	"Locked keypad " icon indicates a locked keypad.
	"Locked entry" icon indicates that the contact can not be edited or deleted by the user.
	"Locked handset" icon indicates a locked handset.
	"Personal Services" icon indicates the handset has a 5624 Personal Services license.
	"Personal Alarm" icon indicates the handset has a 5624 Personal Alarm license.
Menu icons	
	The "Contacts" menu contains all of the names/numbers in the local phonebook. In addition, a company phonebook* with up to 1000 entries can be downloaded to the handset using the Portable Device Manager (PDM). You can is also access a central phonebook* from the "Contacts" menu.
	The "Services" menu contains menu short cuts used to customize your phone Only available if the Services or Alarms licenses are installed.
	The "Messaging" menu contains all message handling such as reading and writing messages Only available if the Services or Alarms licenses are installed.

	The "Calls" menu contains the Call list, Missed calls, Presence*, and Diverted calls*.
	The "Connections" menu contains headset selection, system selection, and In charger selection.
	The "Settings" menu contains personal handset settings such as changing the ringer volume and selecting a language
	The "Short cuts" menu contains short cuts for the soft keys, hot keys, navigation keys, and the Multifunction button.
	The "Profiles" menu allows you to add four different profiles. There are no default profiles.

* System dependent

Keys and Buttons

Off-hook Key



This key is used to answer calls, to pre-dial numbers and as a short cut to the Call list. One short press in standby mode opens the call list.

On-hook and On/Off Keys



This key is used to disconnect calls and return to the main screen. A long press in standby mode switches the handset on/off.

Navigation/Confirmation Key



This key is used to step in the menu and is used when working in text mode. ◀, ▶, ▲, and ▼ are used for stepping left/right and up/down in the menu. The navigation key can be programmed. ▲ is (by default) a short cut to the inbox and ▼ is a short cut to Call contact. During a call you can increase/decrease the volume by pressing ▲ and ▼.

Sound Off Key



A long press on the Sound off Key in idle mode toggles between ring signal on/off. When you receive an incoming call, a long press on the key silences the ring signal. During a call, a long press on the key changes between microphone on/off.

Mute and PTT Button



A long press on the Mute button in idle mode changes between ring signal on/off. When an incoming call is received a long press on the button silences the ring signal. During a call, a long press on the button changes between microphone on/off.

During a PTT call, the microphone is silenced when the PTT button is released.

Key Lock and Upper/Lower Case Key



This key locks the keypad in combination with the soft key "Lock". It is also used for switching between upper/lower case and digits.

Soft Keys

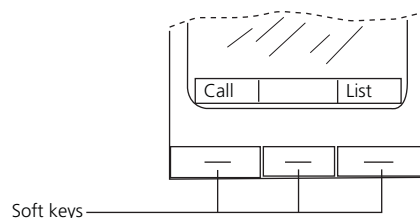

Figure 4: Soft Keys

003

The three soft keys are located just beneath the display. The function of each soft key is indicated by text in the display just above the keys.

In standby mode, the soft keys can be used for specific functions defined by the user of the handset.

Hot Keys

Any key "0", "2" - "9" can be set to a hot key. A long press on any of these numbers in stand by mode provides a short cut to the Call contact list. The list is in alphabetic order. Which key you press depends on where the contact appears in the list.

A hot key can be programmed to give access to frequently used functions such as dialing a specific handset number, a short cut on the menu, or sending an SMS.

Multifunction Button



Note: This feature does not apply to the 5624 Personal Alarm license.

This button can be used as a short cut to functions and has long and double press modes as defined by the user of the handset. If the button is defined, it can be used in standby mode only.

Volume Button

The two buttons on the upper left side of the handset are used for increasing/decreasing the earpiece, headset, and loudspeaker volume.

Alphanumeric Keys

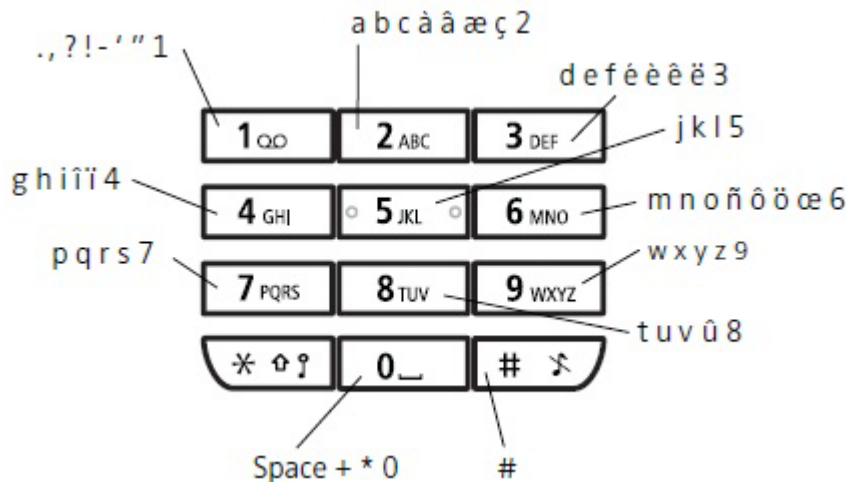

Figure 5: Available Characters



Note: Depending on the selected menu language, other characters can be available. This means that the character order can differ from the table above.

In Standby Mode and Number Input Mode

- A short press on a key enables you to enter the digits “0” - “9” and the characters * and #.
- You enter a pause in the number input mode by a long press on the # key. A pause is indicated by a "P" in the display.

In Text Input Mode

- A short press on a key 0-9, displays the first available character on that specific key. The marked character is selected after a timeout, or when another key is pressed.
- You change to upper/lower case, by pressing the * key before entering the character. The * key can also be used to display only the digits.
- To add space in the text, make a short press on key 0.
- The first character entered in a message, or when adding/editing a name in the Contacts menu, will be an upper level character followed by lower level characters (unless the * key is pressed before you enter the character). To switch between Abc, ABC, abc, and 123 you press the * key.
- A long press on the #-key displays special characters.

Headsets

If you will use your handset frequently, we recommended you use a headset so you have both hands free. The headset comes in two versions: microphone integrated in the cable or microphone on a boom. You can use any headset with a 2.5 mm connector and configure options for the headset using the user's headset profile.

In order to achieve optimal audio quality with your headset we recommend you select the corresponding headset profile. See the *Mitel 5624 Wireless Handset Configuration Guide* for more information.

Customizing Your Phone

Switch the Handset On

When the handset is switched off:

1. Press and hold the On-hook key .

When pressing the On-hook key, the handset vibrates and the display lights up.

2. Press "Yes" to confirm.

Switch the Handset Off



Note: If the handset is a shared phone, it must first be logged out to be able to switch off the handset. See the *Mitel 5624 Wireless Handset Configuration Guide*.

1. Press and hold the On-hook key .

The "Switch off?" window appears.

2. Press "Yes" to confirm.

Log a Shared Phone On/Off



Note: This feature requires that the parameter "Phone mode" is configured. See the *Mitel 5624 Wireless Handset Configuration Guide*.

The shared phone feature allows more than one user to use a handset. All parameters and settings that are set in the Device Manager are loaded onto the handset upon logon. Parameters that are changed in the handset by a logged-in user are stored by the Device Manager. When the handset is logged out or switched off, the message list and call list in the handset disappears and will be empty when a new user logs onto the handset.

The 5624 handsets are configured to be shared using the Device Manager. When a handset is configured to be a shared phone, it can be used by any shared phone user in the system. The user profile must have the "personal phone" parameter disabled. If the user is configured as personal (that is, not shared), the handset will become a personal phone upon first log on.

Log On a Handset

Before you log on to the handset, ensure it has been switched on. See the *Mitel 5624 Wireless Handset Configuration Guide* for more information.

1. When the "Login?" window appears, press "Yes".
2. Enter the user name.
3. If required, enter the password.
4. Navigate by using Up and Down on the Navigation key.
5. Press "Log in".



If the handset does not find the WLAN upon start-up a "No Network" window appears. If the handset does not receive an IP address from the system a "No Access" window appears.

Log Off a Handset

Note: The handset must be in idle mode. While in a menu, press the End key to return to idle mode.

1. Press and hold .
2. When the "Log off?" window appears, press "Yes".

Turn On/Off the Audible Signal

The handset must be in idle mode. A long press on the  or  in idle mode toggles the ring signal on/off.

The  icon indicates a silenced handset.

Lock/Unlock the Keypad

Lock/Unlock the Keypad in Idle Mode

You can lock keys to prevent you from accidentally pressing them.

1. Press .
2. Press "Lock".

Unlock keypad

1. Press .
2. Press "Yes".



Note: You can answer/close an incoming call and/or press the alarm button while the keypad is locked. If configured in Portable Device Manager (PDM), you can call a pre-defined emergency number while the keypad is locked. See the *Mitel 5624 Wireless Handset Configuration Guide*.

Lock/Unlock the Keypad during a Call

To prevent accidentally pressing keys you can lock keys during a call. This is useful when wearing a headset and a handset attached to a pocket or belt.

Lock the Keypad

1. Press .
2. Press "Lock".

Unlock Keypad

1. Press .
2. Press "Yes".



Note: You can press the volume buttons and the mute button during the call. If the 5624 Personal Alarm license is used it is also possible to press the alarm button.

Lock/Unlock the Handset

The handset can be protected from unauthorized use.



1. Enter the "Settings" menu. *See the Mitel 5624 Wireless Handset Configuration Guide.*
2. Select "Locks"
3. Select "Phone lock".
4. Select "Auto phone lock"
5. Select "On", "On in charger", or "Off".
6. Enter your PIN code.
7. Press "OK".



Note: If the handset is configured in PDM you can call a pre-defined emergency number while the handset is locked. *See the Mitel 5624 Wireless Handset Configuration Guide.*

Making and Answering Calls

Call List

1. Press "Menu",
2. Select "Calls" .
3. Select "Call list".
4. Select a number.
5. Press  or the "Call" soft key to dial. The number can be edited before the call is dialled. Press "More" and select "Edit number". The 25 last received, dialled, or missed calls are stored in a call list. See the *Mitel 5624 Wireless Handset Configuration Guide*.

Make a Call

Pre-Dial

Enter the number on the handset and press  to get the line. The number is shown on the display while dialling. If required, you can press the "Clear" soft key to erase the number. You can use the navigation key to step and add/delete a digit in the middle of a number.

You can turn on the tone sender in a pre-dialled number with a long press on the *-key.

Dial Using a Pre-programmed Hot Key, Soft Key or Multifunction Button



Note: The Multifunction button does not apply to the 5624 Personal Alarm license.

The Multifunction button, hot keys, and soft keys can be programmed with a handset number. Press the pre-programmed hot key, soft key or Multifunction button to dial the number. The call will automatically be connected.

Dial a Number from the Call List

1. Press .
2. Select a number and press  or the "Call" soft key to dial.

The number can be edited before the call starts.

3. Press "More".
4. Select "Edit number".

Dial the Sender of a Message

You can call the sender of a message stored in the message list, from the Messaging menu.

1. Open the menu by pressing the confirmation button, or press "Menu".
2. Select "Messaging".
3. Select "Inbox".
4. Select a message from the list.
5. Select "View".
6. Select "More".
7. Select "Call sender".

Dial a Number from the Local Phonebook

1. Press "Menu".
2. Select "Contacts".
3. Select "Call contact".
4. Select a contact from list, or search name/number by entering characters in the "Search" field.
5. Press the "Call" or the Off-hook soft key to make the call.

Dial a Name from the Central Phonebook

1. Press "Menu".
2. Select "Contacts".
3. Select "Central phonebook".
4. Select "Search by name".
5. Enter the first name and/or the last name. The whole name does not have to be entered.
6. Press "Search".
7. Press the "Call" or the Off-hook soft key to make the call.

Dial a Number from the Company Phonebook

1. Press "Menu".
2. Select "Contacts".
3. Select "Call contact".
4. The local and company phonebook appears in the same list but the company names are indicated by a "Locked entry" icon  in front of the name. Select a contact from the list or search for the name/number by entering characters in the "Search" field.
5. Press the "Call" or the Off-hook soft key to make the call.



Answer a Call

The flashing LED, accompanied by a ring signal and/or a vibrating handset, notifies you of calls. The ring signal and vibrator can be disabled. The calling party's handset number or name is shown. The name will be shown if the calling party's handset number is stored in the local phonebook. When a headset is connected to the handset, the answering button on the headset can be used to answer the call.

Other answering methods can be specified in the Settings menu. See the *Mitel 5624 Wireless Handset Configuration Guide*. The answering methods are Automatically, Loudspeaking, and Quick answer.

When "Automatically" is enabled, all incoming calls are connected automatically.

Answer a Call

When the signal sounds press  to answer the call, or press the  soft key to answer the call in loudspeaking mode. The name/number of the calling party appears if calling line information is available.

End a Call

Press  to end the call.

The duration of the call is shown in the display. The total time of the call can also be retrieved from the Calls menu > Call time.

During a Call



Note: Some of these functions are system dependent. The parameters are set up in PDM. See the *Mitel 5624 Wireless Handset Configuration Guide*, and the *Mitel Portable Device Manager Installation and Maintenance Guide*.

Additional In-call functions can be added by the administrator.

If the handset is configured in PDM you can call a pre-defined emergency number while the handset/keypad is locked. During the ongoing emergency call, the "More" soft key is disabled.

Adjust the Volume during a Call

Press the "Volume up" button to increase the volume, and the "Volume down" button to decrease the volume. The handset will now store and keep the new volume level. You can also use the navigation keys ▲ and ▼ to adjust the volume.

Open Contacts during a Call

1. Press the "More" soft key.
2. Select "Contacts".
3. Press "Select".
4. Select "Call contact" to search a local or company phonebook contact, or select "Central phonebook" to search a central phonebook contact.
5. Press "Select".
6. Select a contact.



Note: You can call the selected contact by pressing "Call". When calling the contact, the first call will be put on hold. See the *Mitel 5624 Wireless Handset Configuration Guide*.

Turn on/off the Microphone during a Call

1. Press "More".
2. Select "Microphone off".
3. Press "Select".

The icon  indicates a silenced microphone. This means that the other party in an ongoing call cannot hear you.

To turn the microphone back on:

1. Press "More".
2. Select "Microphone on".
3. Press "Select".

You can turn the microphone off/on by a long press on .

Lock/Unlock the Keypad during a Call

To prevent accidentally pressing keys, you can lock the keys during a call. This can be useful when a headset is used and the handset is attached to a pocket or belt.

Lock the Keypad



1. Press .
2. Press "Lock".

Unlock the Keypad

1. Press .
2. Press "Yes".

You can press the volume buttons and the mute button during the call. If the 5624 Personal Alarm license is used, it is also possible to press the alarm button.

Start a New Call during a Conversation

1. Press "More".
2. Select "New Call".
3. Press "Select".
4. Enter the number, or press  to access the phonebook.
5. Press .

Call Handling

During a call you may need to use features, such as Hold, Transfer, Conference, Callback, and Call Park.

You access these features during a call by pressing the "More" soft key. It displays the In Call menu.

Hold

1. Press the "More" soft key.
2. Select "Hold" to put the call on hold.

To Retrieve a Held Call

1. Select "Retr." to retrieve the call.

Transfer to a New Call (Unsupervised)

To transfer a call to another party when there is one ongoing call:



1. Press "More".
2. Select "Transf. to new".
3. Press "Select".
4. Enter the number to which the party will be connected or select a contact in the local or company phonebook.
5. Press "OK" to transfer the call.

Supervised Transfer

1. Press "More".
2. Select "New Call."
3. Enter the number to which the party will be connected or select a contact in the local or company phonebook.
4. Press "More".
5. Select "Transf. to <extension>".
6. Press "Select".

Conference

Prerequisite: A new call has been started during conversation. See Start a New Call during a Conversation on page 21. A call has to be invited to the conference call as follows:

1. Step to the call on hold (indicated with ) with the five-way Navigation key.
2. Press "More" during the call.
3. Select "Conference". Now two people are in an ongoing call (indicated with ).

The person initiating the conference call is the conference leader, and the other are participants of the conference call.

Conference Split

1. If desired, either of the participants in the ongoing conference call can be put on hold by selecting the soft key "More" and selecting "Hold name".
2. Continue talking with the other party.
3. To rejoin the two lines, select the held line (indicated with ).
4. Press "More".
5. Select "Conference."

Answer Call Waiting

While on a call, if you hear a two-beep tone for an incoming call, the soft keys "Accept" and "Decline" are displayed.:

1. Press "Accept" to answer the incoming call.

The new call is connected and the first call is placed on hold.

2. You can press the "Retr." soft key to alternate between calls.

The call on hold is indicated with  and the ongoing call is indicated with .

3. Any of the calls can be ended by pressing the "End" soft key.

Call Park

The Call Park feature allows you to place a call in a special hold state. You, or someone else, can then retrieve the call from any extension in the system. After parking the call, the system can automatically connect you to paging equipment so that you can announce the call to the requested party.

To park a in-progress call:

1. Press "More".
2. Select "Call Park".
3. Dial the directory number on which to park the call.
4. Inform the called party of the waiting call.

To retrieve a parked call:

1. Press "Call -> Call Services".
2. Select "Call Park Retrieve" and enter the directory number on which the call is parked.

Advanced Features

The following features are available from the Calls, Call Services menu. See “Calls Menu” on page 48.

- Call Forward
- Call Forward Cancel
- Do Not Disturb
- Do Not Disturb Cancel
- Call Pickup
- Call Park Retrieve
- Direct/Group Page

To access the Call Services menu:

- Press "More".

The following table lists the Calls > Call Services menu features and associated feature access code methods.

In-Call Menu under More	Associated Feature Access Code
Call Forward - (I am here)	Off hook + **8
Call Forward Cancel	Off hook + ##8
Do Not Disturb	Off hook + *5
Do Not Disturb Cancel	Off hook + #5
Call Pickup	Off hook + *6
Call Park Retrieve	Off hook + *8#
Direct/Group Page	Off hook + *37

Call Forward

To set call forwarding:

1. Select “Call services” in the “Calls” menu.
2. Select “Call Forward”.
3. Enter the extension number to which you want to forward your calls.
4. Press “Call”.

To cancel call forwarding:

1. Select “Call services” in the “Calls” menu.
2. Select “Call Forward Cancel”.

Forwarding is cancelled.

Call Pickup

To answer a call that is ringing at another station in your Pickup Group:

1. Press "More".
2. Select "Call Pickup".
3. Answer the call.

Do Not Disturb

To activate Do Not Disturb:

1. During the call, press the "More" soft key.
2. Select "Do Not Disturb".

Do Not Disturb is activated.

To deactivate Do Not Disturb:

1. During the call, press the "More" soft key.
2. Select "Do Not Disturb Cancel".

Do Not Disturb is deactivated.

Direct Page

Direct Paging allows you to page a party through the party's hands free speaker.

1. Press "More".
2. Select "Direct/Group Page".
3. Dial the extension number.
4. Speak to the called party.

Group Page

Group Paging allows you to page a group of telephones through their built-in speakers.

1. Press "More".
2. Select "Direct/Group Page".
3. Perform one of the following actions.
 - Press # to page your prime page group.
 - Dial the page group directory number to page a specific page group.
4. Speak to the dialed party.

Messaging

Message List

The thirty last received messages are stored in a list. The message list is located in the Messaging menu "Inbox". Time and date information is included in the message.

Receive a Message

Incoming Message for the 5624 Services License

When a text message is received, the LED starts flashing and the message alert signal sounds. The "New message" icon, and the content of the received message are automatically displayed. The icon will remain in the display until all new messages are opened. If the message is received during a call a beep notifies the user.

You can reply or forward the message, call the sender or call the number included in a text. It is also possible to read the message later by selecting "Close". A received message is stored in the Inbox.

Incoming Message for all 5624s except for the 5624 Services License

When a text message is received, the LED starts flashing and the message alert signal sounds. The "New message" icon, and a text with information of received message are displayed. The icon will remain in the display until all new messages are opened. If the message is received during a call a beep notifies the user.

You can select "Yes" to read the message and reply to it, forward it, call the sender, or call the number in text. Alternately, you can select "No" and read the message later. The message is stored in the Inbox.

Read a Stored Message

To read a stored message:

1. Press "Menu".
2. Select "Messaging".
3. Select "Inbox".
4. Select a stored message from the list.
5. Press "View".

Reply to a Message

Press "Reply".

1. Press "Reply".
2. Enter message.
3. Press "Send".
4. if required, edit the number.
5. Press "Send".

Delete a Message

1. Select "Inbox".
2. Select a message to delete.
3. Press "More".
4. Select "Delete".
5. Press "Yes" to confirm.

Forward a Message

1. Select "Inbox".
2. Select a message.
3. Press "View".
4. Press "More".
5. Select "Forward".
6. If required, write additional text.
7. Enter the number to which you will forward the message or press the middle soft key to open the phonebook and select a number.
8. Press "Send" to forward the message.

Call the Sender of the Message

1. Select "Inbox".
2. Select a message.
3. Press "More".
4. Select "Call sender".

Call a Number Included in a Message

If the sender has written a number in the message you can call the number without dialling it.

1. Select "View".
2. Select "More".
3. Select "Call no. in text"¹.
4. Select a number in the list.
5. Press "Call".

Save a Number

1. Select "Inbox".
2. Select a message.
3. Select "View".
4. Press "More".
5. Select "Save number".
6. Select "Work number", "Mobile number", or "Other number".
7. Add a name and press "OK".
8. Press "Save".

The number will be added to the contact list.

Write and Send a Message

1. In the "Messaging" menu, select "Write new message".
2. Write the message. Keys 0-9, * and # can be used. A long press on the #-key displays special characters. See the *Mitel 5624 Wireless Handset Configuration Guide* to view all characters.
3. Press "Send".

You can save the message and send it later by pressing "Back" and selecting "Yes". The message is stored under Unsent messages.

4. Enter a number.
5. Press "Send".

The maximum message length is 160 characters.



Note: Some characters require 2 bytes in the final message; therefore, the user will sometimes not be able to enter 160 characters.

The first character entered will be an upper level character followed by lower level characters unless the * -key is pressed before entering the character.

1. This option is visible only if the number consists of a minimum of 3 digits.

When pressing a particular key, the first available character on the key appears. See the *Mitel 5624 Wireless Handset Configuration Guide*. To access another characters on the key, press the key until the character appears in the display.

For example, to access the character E, press the 3 key twice. "E" appears in the display and is selected after a timeout or when another key is pressed.

Open a Sent Message

1. In the "Messaging" menu, select "Sent".
2. Select a message.
3. Press "View" to read the message.

Send a Message to Another Destination

1. Enter "Messaging" menu. See the *Mitel 5624 Wireless Handset Configuration Guide*.
2. Select "Inbox" or "Sent".
3. Select a message.
4. Press "More".
5. Select "Forward".
6. Press "Send".
7. Enter the number.
8. Press "Send".

Receive a Message with Request for Answer

In the status bar, a message with request for answer is indicated the same way as an ordinary message. See the *Mitel 5624 Wireless Handset Configuration Guide*.

In the message list, the message with request for answer is indicated by the  icon.

Accept/Reject the Message

Press the "Accept" or "Reject" soft key.

When an acknowledged message has been replied to, the icon  is shown in the message list. The text "Accepted" or "Rejected", and the time and date are also added to the acknowledged message.



Note: The option "Delete" is not available for a message with request for answer. An unacknowledged message can be deleted only from the message list.

Message Queuing and Message Priority



Note: This feature applies to the 5624 Services license only.

The default settings is that each message will be displayed without being interrupted by another message, except if the new message is of higher priority. Messages that are not shown yet are placed in a queue and the priority and time of reception determine the position in the queue. There are 9 levels of the priority. 1 is highest priority and 9 is lowest priority.

If several of the messages have the same priority the message that was received first is shown first.

If a new message with a higher priority is received while another message is read the new message will replace the old message in the display. The old message will be placed in the queue. If a new message with equal or lower priority is received while another message is read the new message will be placed in the queue.

You can specify how long a message will be displayed. See the *Mitel 5624 Wireless Handset Configuration Guide*.

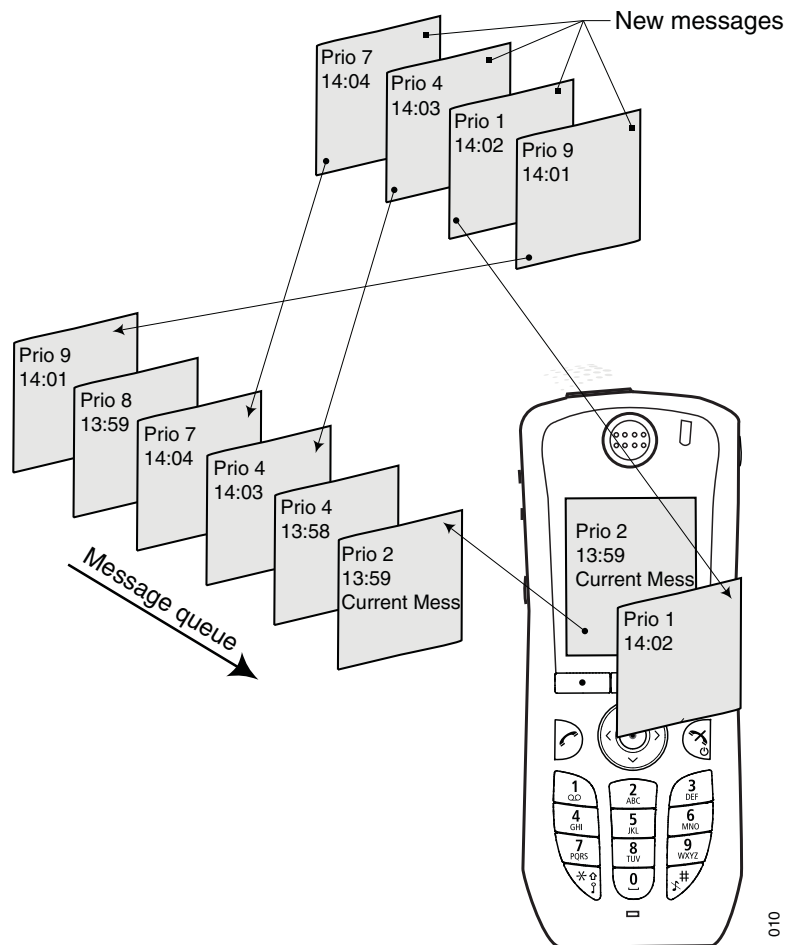



Figure 6: Message Queuing and Priority

Interactive Messaging

 **Note:** This system dependent feature applies to the 5624 Services license only.

Interactive Messaging (IM) is a function that extends basic messaging. It enables handset users to access information from a client application in the system.

For example, customized applications can be accessed from the handset. A list of actions can be included in the message sent from the application to the handset.

An IM is indicated and viewed the same way as an ordinary message. See the *Mitel 5624 Wireless Handset Configuration Guide*. It is saved along with other messages in the message list.

When you read an IM it can display several options. Mark the appropriate IM and press “Select”. If the selected option requests input, enter the information required and press “OK”. Pressing the middle soft key changes the mode to digit or text input depending on the format of the message. A read message is indicated the same way as an ordinary message.

 **Note:** If a handset receives an IM update and the original message was deleted, the handset sends a negative acknowledge (NAK) to the system.

The following figure illustrates a basic interactive message. The options depend on the configuration of the client application.

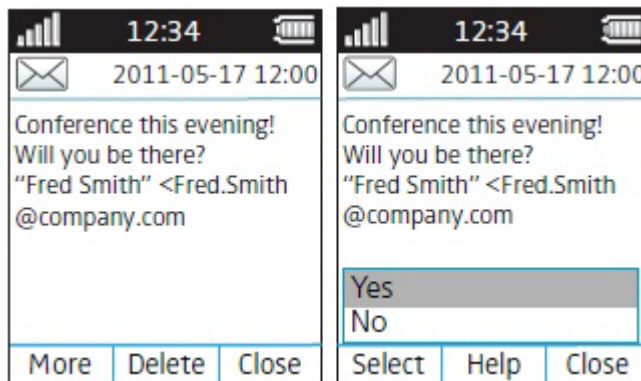



Figure 7: Interactive Message

Mobile data from the handset can instruct the application to send the interactive message. See the *Mitel 5624 Wireless Handset Configuration Guide*. You can then select an action from the list, such as sending a message back to the application and/or dialling a specific number.

Colored Messaging

 **Note:** This is a system dependent feature for the 5624 Services license only.

You can send colored messages to handsets. The application sending the message determines the color of the message. Colored messaging is useful for categorizing messages. In the *Mitel 5624 Wireless Handset Configuration Guide*, there are two colored messages—a new message, and a read message—in the message inbox (left in the figure). The messages are indicated by a gradient color bar behind the envelopes. When reading a message, a gradient color bar is appears below the envelop (right in the figure).

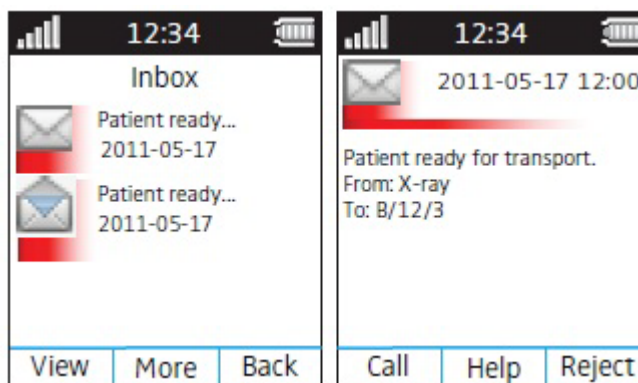



Figure 8: Colored Message

To enable colored messaging, see the corresponding manual for the application used. In addition, colored labels can be mapped to message beep codes. See the *WSM3 Installation and Operation Guide*.

Mobile Data

 **Note:** This is a system dependent feature for the 5624 Services license only.

Send Mobile Data

You can send user entered data from the handset by pressing a pre-programmed hot key or soft key, or selecting a service. Mobile data can be used for actions such as opening a door, or starting or stopping a machine. The data can either be predefined, or entered after the hot key/soft key is pressed or service is selected.

The data can be predefined when programming the soft/hot key or service. See the *Mitel 5624 Wireless Handset Configuration Guide* for more information.

Send Mobile Data with a Prefix

Mobile data with a prefix is sent from the handset by entering data and then pressing a pre-programmed hot key or soft key or selecting a service. Mobile data with a prefix can be used to send information to an application in the system.

You define the prefix when you program the hot/soft key or service. See the *Mitel 5624 Wireless Handset Configuration Guide*.

Voice Mail



Note: This feature is available only if configured in the system.

Receive a Voice Mail

When receiving a voice mail, the content of the voice mail notification appears automatically on the screen, and is also indicated by the “Voice mail message” icon  in the status bar.

If the content of the notification appears, press “Call” to dial the voice mail. If “Close” is selected, you can dial the voice mail by a long press on digit key “1” in standby mode or from the Inbox menu.

Information is stored in the “Messaging” inbox until you listen to the voice mail messages.

Check the Voice Mail Inbox

The voice mail is indicated by a “Voice mail message” icon  in the front of the voice mail message, and is also displayed first in the inbox list.

1. In the “Messaging” menu, select “Inbox”.
2. Select the voice mail message.
3. Press “View”.
4. Press “Call”.

Voice mail will be displayed with one entry in the message list regardless of the number of voice mail received.

One Key Voice Mail Access

A long press on digit key “1” in standby mode will call your voice mail. If the extension number is not available the “Voice mail number not defined” window appears.



Note: Some systems require the mailbox extension number to be downloaded to the handset. See the *Mitel 5624 Wireless Handset Configuration Guide*.

Alarm Operation



Note: The following system dependent features apply to the 5624 Personal Alarm license only. See the *Mitel 5624 Wireless Handset Configuration Guide*.

Push-button Alarm

You press the red alarm button twice within two seconds to activate the alarm. By default the text “Personal Alarm” appears. The alarm is sent to the alarm centre that distributes it further. After that the handset returns to stand-by mode. Note that you can always trigger the alarm when you are speaking, editing your settings, or while the handset is locked.

Acoustic Location Signal

An alarm can be followed by an Acoustic Location Signal (ALS). The ALS is a signal from the handset that sounds for a predefined period of time. You silence the signal by pressing the Mute button on the handset.

Test Alarm

If you press and hold the red alarm button until the (default) “Test Alarm” text appears the following occurs depending on the options specified:

- A beep is heard.
- The orange LED flashes twice.
- The vibrator stirs.
- The handset receives a notification that the alarm has been received by the system.
- If configured, the Acoustic Location Signal (ALS) is activated after the alarm has been sent, or a call is established to a pre-defined number.

If the parameter "Silent alarm" is set, ALS will not be triggered and you will not be notified that the alarm was sent.

- information about the handset's location is sent along with the alarm.

Alarm with Location Information

The 5624 handset is compatible with both the Cisco Mobility Services Engine (MSE) and the Ekahau Real Time Location System (RTLS), which provides a more accurate location than AP Location.

Cisco MSE Location

APs measure the client signal strength for received data packets and forward the measurements to the Cisco Mobility Services Engine (MSE). Your system administrator must configure the 5624 handset for Cisco RTLS.

Ekahau RTLS

The 5624 handset collects information about the APs and their measured radio field strength and forwards the information to the Ekahau Positioning Engine: it calculates the location of the 5624 Handset. Your system administrator must configure the 5624 Handset for Ekahau RTLS. This function requires a license.

Alarm with Data

You must manually define and store the data. To use the function, one soft/hot key/Navigation key in the handset must be defined as a shortcut to the "Edit alarm data" menu. See the *Mitel 5624 Wireless Handset Configuration Guide*. The stored data is added to all types of alarm at transmission.

Automatic Call after Alarm

You can configure a handset to call a pre-defined number after an alarm has been sent. Depending on the settings, the call can be established in the following modes;

- Loudspeaking mode, or
- Monitor mode, or
- Normal mode.

See the *Mitel 5624 Wireless Handset Configuration Guide* for more information.

Menu Tree

Customizing the Menu Tree

You can customize the menu tree, hiding any functions that you do not use. The functions to be hidden are defined in PDM. See the *Mitel 5624 Wireless Handset Configuration Guide*.

Calls 

Call list	>	1234 12:00	>	Call			
		1235 14:00		More	>	Time of call	
		etc.				Edit number	
						Save number	> Work number
							Mobile number
							Other number
						Send message	>
						Delete	> Yes
							No
						Delete all	> Yes
							No
Missed calls	>	2345 15:00	>	Call			
		2346 23 Sep 03		More	>	(same as above)	
		etc.		Back			
Divert calls ^a	>	All calls	>	Enter number:	>	Activ.	
		No reply		(same as above)		(same as above)	
		When busy		(same as above)	>	(same as above)	
				Back			
Presence ^b	>	(examples below)			>	Deactivate	> Yes
		Lunch break	>	Return time			
		Left for the day	>	Return date			No
		Away from desk					
		Meeting	>	Return time			
		Business trip					
		Part-time					
		Vacation	>	Return date			
		Be on leave of absence	>	Return date			
		Back soon	>	Return time			
		Sick-leave					
		VAB (Parental leave)					
		Info					
Call services ^b	>	Call Forward					
		Call Forward Cancel					
		Do Not Disturb					
		Do Not Dist. Cancel					
		Call Pickup					
		Call Park Retrieve					
		Direct Page					
		Group Page					

a. Depends on the VoIP protocol used.
 b. This function is configured by the administrator..

Contacts

Call contact	>	Search			
		From contact list			
Add contact	>	New	>	Name	>
				Work number	>
				Mobile number	>
				Other number	>
				Ring signal	>
		From call list	>		
Edit contact	>	Search			
		From contact list	>	Name	
				Work number	
				Mobile number	
				Other number	
				Ring signal	>
Delete contact	>	Search			
		From contact list	>		
Central Phonebook ^a	>	Search by name	>	Call	
		(First name:)		More	> View contact
		(Last name:)			Add to cont.
					Send message
		Search by number	>	Call	
		(Phone number:)		More	> (same as above)
		Last result	>	Call	
				More	> (same as above)

a. This function is system dependent.

Profile 

Normal	>	Name			
		Volume	>		
		Ring signals	>	Internal call	> Play
					Back
				External call	> (same as above)
				Callback	> (same as above)
		Message alert	>	Play	
				Back	
		Vibrating alert	>	On	
				On if silent	
				Off	
		Key sound	>	Click	
				Tone	
				Silent	
		Answering	>	Answering key	> Hook off
					Any key
			>	Answer behaviour	> Automatically
					Loudspeaking
		Divert calls ^a	>	All calls	> Enter number
					Off
				No reply	> (same as above)
				When busy	> (same as above)
Add new	>	(same as Normal above)			

a. Depends on the VoIP protocol used.

Messaging 

Note: Applicable to Mitel 5624 Services and Mitel 5624 Personal Alarm only.

Inbox	>	Message list	>	View	>	Reply	>	Enter text	>	Send		
						More	>	Delete				
								Forward				
								Call sender				
								Call no. in text ^a	>	Call		
										Back		
								Save number				
						Close						
				More	>	Delete	>	Yes				
								No				
						Delete all	>	Yes				
								No				
				Back								
Write new message	>	Enter text	>	Send	>	Enter number	>	Send				
						"Contacts access"	>	Send				
				Back								
Unsent	>	Message list	>	Edit	>	Send	>	Enter number				
							>	"Contacts access"				
				More	>	Delete	>	Yes				
								No				
						Delete all	>	Yes				
								No				
				Back								
Sent	>	Message list	>	View	>	Forw.	>	Send	>	Enter number	>	Send
										"Contacts access"	>	Send
								Clear				
								Back				
				More	>	Delete	>	Yes				
								No				
								Call no. in text<Superscript >a	>	Call		
								Save number	>	Work No.		
										Mobile No.		
										Other No.		
				Close								
				More	>	Delete	>	Yes				
								No				
						Delete all	>	Yes				
								No				
				Back								

a. Visible if number consists of a minimum of 3 digits.

Services 

The Administrator can configure PPT.

Note: Applicable to Mitel 5624 Services and Mitel 5624 Personal Alarm only.

Add new	>	Enter name	>	Phone call	>	Phone number	>	Enter number	>	Save
								"Contacts access"	>	Save
								Back		
				Send data	>	Enter prefix	>	Enter number	>	Save
										Clear
										Back
				Send message	>	Phone number	>	Enter number	>	Save
								"Contacts access"	>	Save
								Back		
				PTT	>	PTT Groups ^a (example)				
				Edit alarm data	>	Alarm data (example)				
Service 1 (example)	>	Select	>	(Sending message)						
		More	>	Edit						
				Delete	>	Yes				
						No				

a. This function is configured by the administrator.

Short cuts 

Soft Keys	>	Left	>	Name			
				Function	>	Not used	
						Phone call	> Enter number
						Call list	
						Contact list	
						Central Phonebook ^a	
						Message inbox	
						Send message	> Enter number
						Change profile	> Profile A (example)
						Open a menu	> Main menu
							Calls
							Connections
							Contacts
							Messaging
							Services
							Profiles
							Settings
						Presence ^b	>
						Services	>
						Logout	
						Divert calls	
						Show RSSI	
				Control question	>	Off	
						On	
				Value ^c			
		Middle	>	(same as Left key)			
		Right	>	(same as Left key)			
Hot Keys	>	0, 2–9	>	Function	>	(same as above)	
				Control question	>	Off	
						On	
Navigation keys	>	Up	>	Function	>	(same as above)	
				Value ^c			
				Control question	>	Off	
						On	
		Down	>	(same as Up key)			
		Left	>	(same as Up key)			
		Right	>	(same as Up key)			
Multifunction button ^d	>	Long press	>	Function	>	(same as above)	
				Value ^c	>		
				Control question	>	Off	
						On	
		Multi press	>	(same as Long press)			

- a. This function is system dependent.
- b. This function is configured by the administrator.
- c. Dynamic, appears only for certain functions.
- d. Applicable to Mitel 5624 and Mitel 5624 Services only.

Connections

Headset	>	Mic on boom		
		Mic on cable		
		Hearing protection		
Network	>	Select	>	Network A (example)
In charger	>	No action		
		Switch off		
		Sound off		
		Change profile	>	Edit
				Back

Settings

Sound & Alerts	>	Volume	>	Silent, Volume: 1–8	
		Ring signals	>	Internal call	> Fourteen different signals
				External call	> (same as above)
				Callback	> (same as above)
		Message alert	>	Message alert 1 (example)	> Play
					Back
		Vibrating alert	>	On	
				On if silent	
				Off	
		Key sound	>	Click	> Play
					Back
				Tone	> (same as above)
				Silent	
		Battery warning	>	Repeated sound	
				Sound once	
				Sound off	
Locks	>	Automatic key lock	>	On	
				Off	
		Phone lock	>	Auto phone lock	> On
					On in charger
					Off
				Change PIN code	>
Display	>	Brightness	>	Normal	
				Power save	
		Screen saver	>	Information	
				Black	
Time & Date	>	Time format	>	12:00am/pm	
				12:00	
		Date format	>	01 Jul 10	
				Jul 01 2010	
				2010-07-01	
				07/01/2010	
				01/07/2010	
				01-07-2010	
				01.07.2010	

Answering	>	Answering key	>	Hook-off (Call-key)	
				Any key	
		Answering behaviour	>	Automatically	> Change
					Back
				Loudspeaking	> (same as above)
				Quick answer	> (same as above)
Messages	>	Text size	>	Normal	
				Large	
Language	>	German (Deutsch), Dutch (Nederlands), French (Français) and so forth.			
Owner ID	>	Name:			
Alarm ^a		Edit alarm data			
Device info	>	Software			
		Hardware			
		License			
		WLAN info			
		Network info			
		User ID			

a. Applicable to Mitel 5624 Personal Alarm only.

In Call

You access the In Call menu during a call by pressing the "More" soft key.

If the handset is configured via PDM/WSM, you can access a particular function in the In call menu directly by pressing the right soft key.



Note: If the handset is configured via PDM/WSM, you can call a pre-defined emergency number while the handset is locked or the keypad is locked. If calling from a locked handset, you can only access the Microphone on/off function in the In Call menu. However, you can access the entire In Call menu when calling from a handset with a locked keypad.

New call	>	Call				
		"Phonebook access"				
		Cancel				
Transf. to new	>	Call				
		"Phonebook access"				
	>	Cancel				
Hold ^a	>	Retr.				
		More				
		End				
Conference ^a	>					
Contacts	>	Call contact	>	Call		
				View		
				Back		
		Add contact	>	New	>	Name
					>	Work number
					>	Mobile number
					>	Other number
					>	Ring signal
				From call list	>	
		Edit contact	>			
		Delete contact	>			
		Central Phonebook ^b	>	Search by name	>	Search
						Clear
						Back
				Search by number	>	(same as above)
				Last result	>	Call
						More
						>
						Back
Microphone off	>	More	>	Microphone on	>	(same as above)

a. Conditional in-call function.

b. This function is system dependent.

Additional In Call Functions

In addition to the default In Call functions, you can define 10 system specific codes for general purposes.

Navigate the Menu

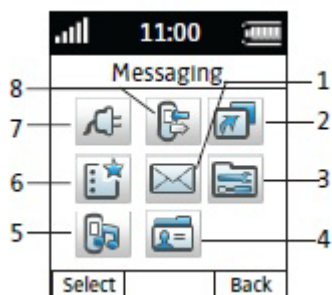



Figure 9: Main Menu

- | | |
|----------------|-----------------|
| (1) Messaging | (5) Profiles |
| (2) Short cuts | (6) Services |
| (3) Settings | (7) Connections |
| (4) Contacts | (8) Calls |

Connections Menu

1. Enter the menu by pressing the "Menu" soft key,, or the confirmation button on the Navigation key.
2. Select  in the menu, and press the confirmation button or the "Select" soft key.

Headsets

In order to achieve optimal audio quality we recommend you specify a headset type: Mic on boom, Mic on cable or Hearing protection.

To specify a headset type:

1. Select "Headset".
2. Select a headset type from the list.
3. Press "Select".

If the pre-configured headset profile does not match the headset in use, or the audio performance is poor, you can configure a headset profile in PDM which will be available in the handset menu. See the *Mitel 5624 Wireless Handset Configuration Guide*.

In Charger

Mute Handset While Charging

When you place the handset in the charger it can be muted while it is charging. When it is removed from the charger it will switch on the sound again.

1. Select "In charger".
2. Select "Other actions".
3. Select "Sound off".

Deactivate the Charging Mode

1. Select "In charger".
2. Select "No action".
3. Press "Select" to save the setting.

Calls Menu

1. Enter the menu by pressing the "Menu" soft key, or the confirmation button on the Navigation key.
2. Select  in the menu and press the confirmation button or the "Select" soft key.

Call List

The 25 last received, dialled or missed calls are stored in a call list. If a number occurs more than once, the last time stamp and the total number of occurrences are shown.



Note: If supported by the system, the number's contact name can be displayed in the call list.

1. Select Call list, and step with the ▲ and ▼ to scroll in the call list.

Dial a Number from the Call list

1. Select a number to call.
2. Press the "Call" soft key to dial.

View the Time of a Call

1. Press the "More" soft key.
2. Select "Time of call".

The time and date are displayed.

Edit a Number from the Call list

1. Press the "More" soft key.
2. Select "Edit number".

Save a Number

1. Press the "More" soft key.
2. Select "Save number".

Send a Message

1. Press the "More" soft key.
2. Select "Send message".

Delete an Entry from the Call List

1. Press the "More" soft key.
2. Select an entry to delete.
3. Select "Delete".
4. Select "Yes" to delete the entry from the list.

Delete all Entries from the Call List

1. Press the "More" soft key.
2. Select "Delete all".
3. Select "Yes" to delete all of the entries from the list.

Missed Calls

1. Select Missed calls, and step with the ▲ and ▼ to scroll in the list.
2. Press the "Call" soft key to call back.

You can use the "More" soft key to view the time/date of the call, edit the received number, add contacts and delete received numbers. See the *Mitel 5624 Wireless Handset Configuration Guide* for information about this functionality.



Note: The number's contact name can be displayed in the Call list if it is supported by the system.

Push to Talk

The Push-to-Talk (PTT) function enables a pre-defined group of mobile staff to participate in a call whereby they all listen to the group's call activity, typically in loudspeaker (Handsfree) mode. Participants press and hold a button in order to speak.

For PTT to function, the PTT-capable handsets in the PTT group must be configured on the Wireless Messaging Services (WSM) Gateway. In addition, a conference bridge, such as Mitel's Audio & Web Conferencing (AWC), must be configured to support the PTT calls.

Two types of PTT calls can be made:

- PTT Voice Style (initiated by the handset)
- PTT Message Style (initiated by the system)

PTT Voice Style Calls (Handset initiated)

Each member of a PTT group is able to initiate a PTT call via a PTT request. This PTT Call request is typically programmed onto a soft key, hot key or multi-function button on the handset for quick access.

After a PTT Call request is made, the system invites the other members of the PTT group into the PTT call. The invitation typically barges onto the invited members' handsets following brief alerting of the incoming PTT call; manual PTT Call acceptance can be configured optionally.

After the PPT group members have received/accepted their PTT invitations, the system automatically dials them onto the configured conference bridge and they become active in the PTT call.





Note: Depending on the configuration, it may take 10 seconds or more for all members to be active on the PTT call from the time a user initiates a PTT request.



Note: Multiple PTT groups are supported; if a handset is a member in multiple groups, the PTT Groups can be programmed onto the handset menu to enable selection of the appropriate PTT group Call request.

Accept a PTT Invitation - Voice Style

The PTT invitation is indicated by a  icon and is received as an incoming call. In the dialog window, a message containing maximum 24 characters can also be shown.

1. Press .

The handset may accept the invitation automatically and start in inverted mute and loud-speaking mode, depending on the configuration of the received PTT invitation.

2. Press and hold the Mute button to open the microphone for transmitting.

The microphone is muted again when the Mute button is released.

Reject a PTT Invitation - Voice Style

- Press  to reject the PTT invitation. The handset will return to the previously shown screen. See the *Mitel 5624 Wireless Handset Configuration Guide*.

PTT Message Style (System/Application initiated)

This mode is typically used in conjunction with an application that triggers the PTT call based on a alarm or communication escalation.



Note: This method requires an additional Alarm Management Server (AMS) module.

Accept a PTT Invitation - Message Style



Note: This feature applies to the 5624 Services license only.

The PTT invitation is received as a message, can contain up to 1000 characters, and is viewed the same way as an ordinary message.

1. Press the "Call" soft key.
The handset may accept the invitation automatically and start in inverted mute and loud-speaking mode, depending on the configuration of the received PTT invitation.
2. Press and hold the Mute button to open the microphone for transmitting.
The microphone is muted again when the Mute button is released.

Reject a PTT Invitation - Message Style ²





Note: This feature applies to the 5624 Services license only.

- Press "Reject" to reject the PTT invitation.

The handset will return to the previously shown screen. See the *Mitel 5624 Wireless Handset Configuration Guide*.

Re-join a PTT Group

If a PTT invitation (PTT Voice Style) is rejected or missed, the PTT group can be dialed from the Call list or from Missed calls, respectively. The PTT invitation is indicated by the  icon in the list. See the *Mitel 5624 Wireless Handset Configuration Guide*.

If a PTT invitation (PTT Message Style) is rejected, the PTT group can be dialed by selecting the message indicated by the  icon in the Messaging inbox, and pressing the "Call" soft key.

Call a PTT Group



Note: PTT group(s) must be defined in PDM and Messaging Group(s) in WSM to be able to use this function. See the *Mitel 5624 Wireless Handset Configuration Guide*, and the *WSM3 Installation and Operation Guide*.

When calling a PTT group, the members in the defined PTT group will receive a PTT invitation as an incoming call (PTT Voice Style).

1. Press "Menu".
2. Select "Calls".
3. Select "PTT groups"¹.
4. Select a PTT group.
5. Press "Call", or the Off-hook key.

Short Cuts Menu

Predefined functions can be set as short cuts for the soft keys, hot keys, navigation keys, and the Multifunction button. For example, you can to define a soft key to make a call, as a short cut for sending a message, or as a short cut to a menu.

1. Enter the menu by pressing the "Menu" soft key, or the confirmation button on the Navigation key.
2. Select  in the menu, and press the confirmation button or the "Select" soft key.

Define Soft Keys

1. Select "Soft keys".
2. Select "Middle" or "Right".
3. Press "Select".
4. Enter a name for the soft key.
5. Press "OK".
6. Select "Function".
7. Select a function from list.
8. Press "Back".
9. Select "Value" (applies to some of the functions).
10. Press "Select".
11. Enter a value (for example, enter a handset number).
12. Press "Back".
13. Select "Control question".
14. Press "Select".
15. Press "Back".
16. Press "Save".

1. Only available if a PTT group is defined in PDM/WSM.

Define Hot Keys

1. Select "Hot keys".
2. Select "0", "2" to "9".
3. Select "Function".
4. Press "Select".
5. Select a function from list.
6. Press "Back".
7. Select "Value" (applies to some of the functions).
8. Press "Select".
9. Enter a value (for example, enter a handset number).
10. Press "Back".
11. Select "Control question".
12. Press "Select".
13. Press "Save".

Define Navigation Keys

1. Select "Navigation keys".
2. Select "Up", "Down", "Left", or "Right".
3. Select "Function".
4. Press "Select".
5. Select a function from list.
6. Press "Back".
7. Select "Value" (applies only to some functions).
8. Press "Select".
9. Enter a value for example a handset number.
10. Press "Back".
11. Select "Control question".
12. Press "Select".
13. Press "Save".

Define the Multifunction or Alarm¹ Button

The Multi-function button can be defined with two different functions: a long press activates one function, and a double press activates another function.

1. Select "Multi-function button"/"Alarm button".
2. Select "Long press", or "Multi press".
3. Select "Function".
4. Press "Select".
5. Select a function from list.
6. Press "Back".
7. Select "Value" (applies only to some functions).
8. Press "Select".
9. Enter a value (for example, enter a handset number).
10. Press "Back".
11. Select "Control question".
12. Press "Select".
13. Press "Save".

Services Menu

A list of predefined menu functions are available. Using the Services menu you can customize the menu with functions you use often.



Note: The Services menu is only available on handsets with a Services or Alarm license.

1. Enter the menu by pressing the "Menu" soft key, or the confirmation button on the Navigation key.
2. Select  in the menu, and press the "Select" soft key.

Add a Service

1. Select "Add new".
2. Enter a name of the service in the field and press "OK".
3. Select a function by using the ▲ and ▼ on the navigation key.
4. Press "Select", or the confirmation button.
5. If necessary, enter values in the fields (applies only to some functions)
6. Press "Back".

1. Applies to the 5624 Personal Alarm license only.

Edit a Service

1. Select a service by using the ▲ and ▼ on the navigation key.
2. Press "More"
3. Select "Edit".
4. Edit the service parameters.
5. Press "Back".

Delete a Service

1. Select a service by using the ▲ and ▼ on the navigation key.
2. Press "More".
3. Select "Delete" by using ▼ on the navigation key.
4. Press "Yes" to delete the service.
5. Press "Back".

Messaging



Note: Messaging is only available on handsets with a Services or Alarm license.

1. Enter the menu by pressing the "Menu" soft key, or the confirmation button on the Navigation key.
2. Select  in the menu, and press the confirmation button or the "Select" soft key.

Inbox

1. Select "Inbox" to view the message list.
2. Select a message by using the ▲ and ▼ on the navigation key.

Reply to a Sender

1. Select "View".
2. Select "Reply".
3. Enter text.
4. Select "Send".

Delete a Message

1. Select "More".
2. Select "Delete".
3. Select "Yes" to delete the message.

Forward a Message

1. Select "View".
2. Select "More".
3. Select "Forward".
4. Enter additional text if required.
5. Select "Send".
6. Enter a number.
7. Select "Send" to forward the message.

Call a Sender

1. Select "View".
2. Select "More".
3. Select "Call Sender".

Call a Number in Text

1. Select "View".
2. Select "More".
3. Select "Call (No. in text)"¹.
4. Select a number from the list.
5. Select "Call"

Save a Number

1. Select "View".
2. Select "More".
3. Select "Save number".
4. Select "Work Number", "Mobile number, or "Other number".
5. Press "Add".
6. Enter a name for the contact.
7. Press "OK".
8. Press "Save". The number will be saved in the contact list.

1. Only visible if the number consists of minimum 3 digits.

Write New Messages

1. Select "Write new message".
2. Enter text, and press "Send". See the *Mitel 5624 Wireless Handset Configuration Guide*. It is possible to save a message and send it later by pressing the soft key "Back" and selecting "Yes". The message will be stored under Unsent messages.
3. Enter a number or press the middle soft key to open the phonebook.
4. Press "Send".

Unsent Messages

1. Select "Unsent" to view the list.
2. Select message to edit/send.
3. Select "Edit", edit text and/or just select "Send".

Delete/Delete All

1. Select "More".
2. Select "Delete" or "Delete all".
3. Select "Yes" to delete the message not sent.

Sent Messages

1. Select "Sent" to view the list.
2. Select "View".

Forward a message

1. Enter additional text if required.
2. Enter a number or press the middle soft key to open the phonebook.
3. Select "Send".

Delete a Message

1. Select "Delete".
2. Select "Yes" to delete the message.

Delete/Delete All

1. Select "More".
2. Select "Delete" or "Delete all".
3. Select "Yes" to delete the unsent message.

Profiles Menu

You can set up your own profiles for incoming calls, message alerts, vibrating alerts and key sounds. This can be useful when there are many users on the same handset and they want different sound profiles. It can also be used for temporarily settings, for example to silence the ring tone for incoming calls while in a meeting. You can readily switch between different profiles.

1. Enter the menu by pressing the "Menu" soft key, or the confirmation button on the Navigation key.
2. Select  in the menu.

Add a new Profile

1. Press "Add new".
2. Enter name of the profile.
3. Select "Save".
4. Press "More".
5. Select "Add settings".
6. Select the settings to be added to the profile.
7. Repeat steps 3 to 6 to add additional settings.
8. Select a setting and press "Edit" to make the changes.

Delete a Profile

1. Select a profile from the list.
2. Press "More".
3. Select "Delete" from the list.
4. Press "Delete".
5. Press "Yes" to confirm.

Edit a Profile

1. Select a profile from list.
2. Press "More".
3. Select "Edit" from menu.
4. Select the information to be edited.
5. Press "Edit".
6. Perform any of the following options:
 - Edit a setting by marking it and then press "Edit".
 - Add additional settings by pressing "More" and selecting "Add setting" or "Import from".
 - Remove a setting by selecting it and selecting "More > Remove setting".
7. Make changes and press "Save" to confirm.

Contacts Menu

The handset has a local phonebook with 250 entries: you can add, delete, or edit names and numbers. The phonebook lists all names in alphabetical order. three numbers can be added for each contact: work number, mobile number, and other number.

In addition, you can download a company phonebook to the handset via the PDM/WSM. You cannot edit or delete the company phonebook names and numbers. The phonebook lists all names in alphabetical order. The local and company phonebooks appear in the same list but the company names are indicated by a "Locked entry" icon  in front of the name. The contact will include only the work number. See the *Mitel 5624 Wireless Handset Configuration Guide* for more information.

You can also access a central phonebook¹. See the *Mitel 5624 Wireless Handset Configuration Guide*. You send a request to a messaging server with the first characters entered and the messaging server returns a list of names and numbers that matches the search.

1. Enter the menu by pressing the "Menu" soft key, or the confirmation button on the Navigation key.
2. Select  in the menu. See the *Mitel 5624 Wireless Handset Configuration Guide*.

Call a Contact

1. Select "Call contact".
2. Select contact from the list or enter name or number in the search field.
3. Press the "Call" soft key.

You can select "View" > "More" to edit the contact and send a message.

Add a Contact

1. Select "Add contact".

Add a New Contact

1. Select "New".
2. Select "Add".
3. Enter the name of the contact.
4. Press "OK".
5. Select "Work Number", or "Mobile number", or "Other number".
6. Press "Add".
7. Enter a number and press "OK".
8. Press "Save".
9. Press "Back".

Different ring signals can be set to distinguish between contacts.

1. This is a system dependent function.

Add a Contact from the Call List

1. Select "From call list".
2. Select a number.
3. Press "Add".
4. Select a number type.
5. Press "Add".
6. Enter a name for the contact.
7. Press "OK".
8. Press "Save".

Edit a Contact

1. Select "Edit contact".
2. Select a contact.
3. Press "Edit".
4. Select "Work Number", or "Mobile number", or "Other number".
5. Press "Edit".
6. Enter a new name or number.
7. Press "OK".
8. Press "Save".

Delete a Contact

1. Select "Delete contact".
2. Select a contact.
3. Press "Delete".
4. Press "Yes" to confirm.

Central Phonebook

In the Central Phonebook it is possible to search by name or number.

When the search result is ready you can view contact information, add the number to a new contact, or send a message by selecting the "More" soft key. You can also call the number by selecting the "Call" soft key.

- Select "Central phonebook".

Search by Name

1. Select "Search by name".
2. Enter a first name and/or a last name.
3. Select "Search".

The search result appears.

Search by Number

1. Select "Search by number".
2. Enter a handset number.
3. Select "Search".

The search result appears.

View the Last Search Result

1. Select "Last result".

Only the last result appears.

Settings Menu

The following settings apply to the 5624 handset.

1. Enter the menu by pressing the "Menu" soft key.
2. Select  in the menu.

Sound and Alert Settings

Adjust the Ringer Volume

1. Select "Sound & Alerts".
2. Select "Volume".
3. Step with ► to increase the volume and with ◀ to decrease it.
4. Press "Back" to save the setting.

Set Ring Signals for Internal Calls, External Calls and Call Backs

1. Select "Sound & Alerts".
2. Select "Ring signals".

You can set different signals for internal calls, external calls and call backs.

3. Select "Internal call", "External call", or "Callback".

The handset has 14 different ring signals.

4. Select a sound.

You can press "Play" to listen to the different sounds.

5. Press "Back".

Set Message Alerts for Mail

1. Select "Sound & Alerts".
2. Select "Message alert".

You can select from 8 different message alerts.

3. Select a message alert from list.

You can press "Play" to listen to the different sounds.

4. Press "Back".

Turn the Vibrator On/Off

1. Select "Sound & Alerts".
2. Select "Vibrator alert".
3. Select "On", "On if silent" (that is, the vibrator is on when the handset is muted), or "Off".
4. Press "Back".

Set the Key Sound

When you set the sound key, every time a key is used the handset produces a faint sound.

1. Select "Sound & Alerts".
2. Select "Key sound".
3. Select "Silent", "Click", or "Tone".
4. Select a key sound.
5. Press "Back".

You can listen to the key sound by pressing the "Play" soft key.

Phone Lock Settings

Activate the Automatic Key Lock

1. Select "Locks".
2. Select "Automatic key lock".
3. Select "On" to activate the automatic key lock.



Note: You can answer/close an incoming call and/or press the alarm button while the keypad is locked. If configured in PDM/WSM, you can call an emergency number while the keypad is locked. See the *Mitel 5624 Wireless Handset Configuration Guide*.

Activate the Phone Lock

You can protect a handset from unauthorized use. If the Activate phone lock function is activated you must enter a PIN code at power on, or when the handset is placed in a charger. The phone lock is activated when the handset is placed in the charger. The default phone lock code (0000) can be changed to any 4 -8 digit code.



Note: If configured in the handset, you can call an emergency number while the handset is locked. See the *Mitel 5624 Wireless Handset Configuration Guide*.

1. Select "Locks.
2. Select "Phone Lock".
3. Select "Auto phone lock".
4. Select "On", or "On in charger".
5. Enter a PIN code.
6. Press "OK".

If the PIN code is forgotten it can be removed by your distributor.

Deactivate the Phone Lock

1. Select "Locks > "Phone Lock" > "Auto phone lock".Select "Phone Lock".
2. Select "Off".
3. Enter a PIN code.
4. Press "OK".

Change the PIN Code

1. Select "Locks".
2. Select "Phone Lock".
3. Select "Change PIN code".
4. Enter the old PIN code.
5. Press "OK".
6. Enter a new PIN code twice.
7. Press "Save".

Display Settings

Screen Saver

1. Select "Display".
2. Select "Screen saver".
3. Select "Information", or "Black".

Selecting "Information" displays time and status information. The display turns off when the handset is not used.

4. Press "Back".

Brightness

1. Select "Display".
2. Select "Brightness".
3. Select "Normal" or "Power save".
4. Press "Back".

Contrast

1. Select "Display".
2. Select "Contrast".
3. Increase/decrease the contrast by pressing ▲ and ▼ on the Navigation key.
4. Press "Back".

Time and Date Settings

The time and date are received from the system. If the time and date are changed in the system, it takes up to 24 hours before the changes appear in the handset. If the handset is turned off and then turned on, the changes will be applied immediately. However, it is possible to change the format of the time and date.

Set the Time Format

1. Select "Time & Date".
2. Press "Select".
3. Select a time format.

The actual time format will be displayed. The time formats include:

- 12:00 (AM/PM)
- 24:00

4. Press "Select" to save the setting.

Set the Date Format

1. Select "Time & Date".
2. Press "Select".
3. Select "Date format".
4. Press "Select".

The date formats include:

- DD MMM YY, for example 30 Jan 11
- MMM DD YYYY, for example Jan 30 2011
- YYYY-MM-DD, for example 2011-01-30 (ISO 8601)
- MM/DD/YYYY, for example. 01/30/2011 (also called US)
- DD/MM/YYYY, for example 10/01/2011 (also called Europe)
- DD-MM-YYYY, for example 30-01-2011
- DD.MM.YYYY, for example. 30.01.2011

5. Press "Select" to save the setting.

Answering

By default the handset uses the Off-hook key when answering calls. You can configure the handset to answer calls automatically (without pressing a key) and can set loudspeaking mode. You can associate the answering behavior with any key. If you select "Any key", any key except the "On-hook" and "Sound off" keys, can be used to answer a call.

1. Select  in the menu. See the *Mitel 5624 Wireless Handset Configuration Guide*.
2. Select "Answering".

Answering Key

By default the answering key is set to *Hook-off*.

1. Select "Answering key"
2. Select "Hook-off" or "Any key".
3. Press "Back" to save the setting.

Answering Behavior

1. Select "Answering behaviour".
2. Select "Automatically", "Loudspeaking", or "Quick answer".

At Quick answer, the call is connected by lifting the handset out of the charger.

3. Press "Change" to change the setting.

The check box will be selected.

4. Press "Back" to save the setting.

5. To optionally remove the setting, press "Change".

The check box will be cleared.

Change Text Size for Messages

1. Select "Messages".
2. Select "Text size Normal".

The default text size is "Normal".

3. Select "Normal" or "Large".
4. Press "Back".

Change the Menu Language

1. Select "Language".
2. Select the language to be used: Brazilian Português (Brazilian Portuguese), (Czech), Dansk (Danish), Deutsch (German), English, Español (Spanish), Français (French), (Greek), (Hungarian), Italiano (Italian), Nederlands (Dutch), Norska (Norwegian), (Polish), (Russian), (Slovakian), Soumi (Finish), Svenska (Swedish), or (Turkish).
3. Press "Back".



Note: The languages mentioned above are the default languages. You can download an additional language to the handset. See the *Mitel 5624 Wireless Handset Configuration Guide*.

Change Owner ID

The Owner ID is set to identify the handset.

1. Select "Owner ID".
2. Enter a name/identity.
3. Press "Save".

To view the handset's software version, enter *#34# in idle mode.

Troubleshooting

This section contains information on how to solve common operational problems and warnings you may receive.

If you cannot resolve the issue contact your system administrator.

If others are experiencing similar problems there may be a system error.

Operational Problems

Fault	Probable cause	Action or comment
No display	The battery level is low or the handset is defective.	Charge the battery or contact the system administrator.
No ringing	The sound off icon is on, or the ringer volume set to silent, or the handset is defective.	Long press the Sound off key to increase the volume or contact system the administrator.
No change in Time & Date setting	PBX dependent	Changes in the handset appear 24 hours or sooner after a system change or by turning on and off the handset.

Error or Warning Messages

Display shows	Probable cause	Action or comment
No access	The network is in range but there are no access rights.	Switch off the handset and then switch it on again or contact your system administrator.
No System. The handset beeps once a minute (during max 30 minutes) with a low tone followed by a high tone (if enabled, the vibrator also follows the beeps).	The handset is out of coverage or handset is defective.	Stop the beep with the Sound off key and go into range. Note: When re-entering the coverage area it can take a couple of minutes before the handset automatically registers with the system. or contact the system administrator.
SERVICE required Parameters corrupt Note: This display message is only shown in English.	The handset is defective.	Select the reset option on the middle soft key if available. If no reset option is available or fault does not resolve the issue the handset needs repair.
SERVICE required Invalid IPDI Note: This display message is only shown in English.	Easy replacement procedure not followed correctly or failure during easy replacement procedure.	Send the handset for service.
Enter PIN code	The handset's lock is activated.	Enter the required PIN code. If the PIN code is lost enter a new one via PDM or do a factory reset via the PDM.
Battery low, charge now	The battery level is low.	Charge or replace the battery.
Phonebook is not available at the moment.	The phonebook does not respond, not available at the moment.	Try again later. If the fault persists do a factory reset via the Admin menu or PDM.
Voice mail number not defined	There is no Voice mail number defined in the handset.	Define a Voice mail number via the PDM.
Could not encrypt connection.	The parameter "Encryption Required" is enabled in the handset in combination with; 1. Unencrypted base station(s); and/or, 2. Unsupported base station(s).	1. Disable the "Encryption Required" parameter in handset; and/or, 2. Enable the encryption in the base station(s); and/or, Note: If a base station(s) is used, the software version must be 3.1.x or later. 3. Use supported base station(s). Ask your supplier.

Display shows	Probable cause	Action or comment
Not allowed	<p>1) The handset that has shared phone functionality enabled cannot be logged in because another handset/user is using the extension.</p> <p>Note: If you require a password (AC code) to log in a handset and the handset is logged in, you can log in a second handset. The first logged in handset will automatically be logged out.</p> <p>2) The extension (user) does not exist.</p> <p>3) The password is incorrect.</p>	<p>1) Log out the handset that uses the extension.</p> <p>2) Make sure that you entered the correct extension. if required, contact the system administrator.</p> <p>3) Make sure you have entered the correct password. Contact the system administrator if you have forgot the password.</p>

LED Error Indications

See the *Mitel 5624 Wireless Handset Configuration Guide*.

LED is flashing red, quick flash, (100 ms on, 800 ms off)

1. If a third handset, that is another handset than the "old" (the replaced handset) and "new" (the replacement headset) handset, is inserted into the charger during Easy Replacement, this error indication appears. Change to the correct handset.
2. The charger has found that Easy Replacement does not work. Change back to the "new" handset.

LED is flashing red, long flash (800 ms on, 100 ms off)

Error during Easy Replacement. *Both* telephones need to be sent for service.

Operation Notice

Accessibility and Voice Quality



The base network is not always available. If you do not get in contact with your system, contact your system administrator. For best voice quality, avoid positioning near computer, radio or similar equipment.

Operating Area

You can only use the handset in the area that is covered by your system. Outside this area you will loose contact with the system. The signal strength icon will be low and “Searching” will appear.

Out of Range

When you leave the system's coverage area a short beep sounds and the text “Searching” will appear in the display.



The out of range beep will be repeated every minute for 30 minutes. You can turn off the sound by long pressing  , or .



When re-entering the coverage area it can take a couple of minutes before the handset automatically registered with the system.

Maintenance

Maintenance of Batteries



Battery Warnings

	<p>The "Low battery" icon appears when the battery has 10% or less remaining capacity. In addition; a warning signal sounds every minute, the LED flashes orange, and the dialog window shows "Battery low". "Charge now" appears.</p>
	<p>The "Empty battery" icon flashes when the battery has 5% or less remaining capacity. In addition; a warning signal sounds every second, the LED flashes red, and the dialog window "Battery empty. Shutting down." appears.</p>

During a call, only the corresponding battery warning signal will notify the user. The warning signal cannot be silenced during a call. When not in call, the warning signal can be silenced by pressing  or .

Charge the Battery

Place the handset in the desktop charger or in the rack charger. The battery is being charged when the LED on the handset is steady orange. When the battery is fully charged the LED will be green.

The animated  battery icon indicates the battery is charging. The  icon indicates a fully charged battery.



Note: Only use the prescribed chargers for charging.

Charge Spare Batteries

Spare batteries can be charged with a separate battery pack charger. It can charge six batteries at the same time.

Replace the Battery

If the standby time for the handset becomes too low you must replace the battery with a new one. Contact your system administrator or your supplier to obtain new batteries.

Attach the battery as described in the following illustration. You attach the battery inside the battery lid. It is connected it to the handset in such a way that "no miss-contact" is possible.

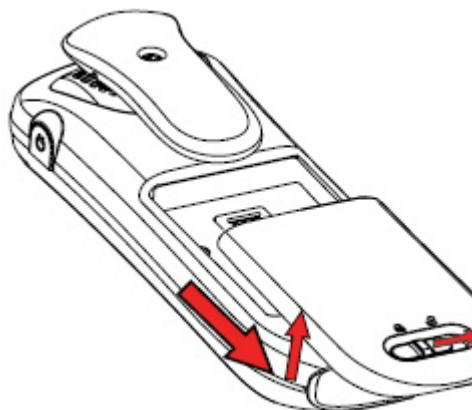

Figure 10: Easy Replaceable Battery - Unlock the Lid and Remove the Battery

Easy Replacement of Handset

Easy replacement can be used if a handset needs to be replaced. The easy replacement procedure is done via the handset display and the 5624 Programmer, or the rack charger.

The following settings are replaced during easy replacement:

- registration
- User parameters (including User ID)
- Contacts
- The extension number is assigned to the new handset.

The following settings are not replaced during the easy replacement:

- Call list
- Messages
- License(s)¹

Before Starting the Easy Replacement Procedure

1. Check that both the old handset (that is, the handset to be replaced) and the new handset (that is, the replacement handset) are of the same device type (5624).



Note: It is possible to perform Easy Replacement between different licenses (that is; 5624 Standard, 5624 Services, 5624 Personal Alarm, and 5624 Location). The new handset's license is not replaced by the old handset's license during the procedure¹.

2. Make sure that the handset batteries are charged before starting the easy replacement procedure.
3. Switch off the **new** handset by long pressing .

1. A license (that includes the handset variant and/or license dependent features) can be moved to another handset using PDM/WSM.

Easy Replacement Procedure

During the Easy Replacement procedure, the LEDs of the handset and the charger follow the same LED indications. This means that if the old handset has a broken display, the LED indications on the charger and on the handset can be used to follow the replacement procedure. Before and after easy replacement, the LEDs may have different LED indications. For more details, see the *Mitel 5624 Wireless Handset Configuration Guide*.

IMPORTANT: Never remove a handset from the charger until the instructions in the display or the LED tells you to do so. (See the status on the LED if the display is broken). If an error is indicated you may be able to remove the handset. See the *Mitel 5624 Wireless Handset Configuration Guide* for further instructions.

After you place the old handset in the charger, you must place the new handset in the charger, regardless of whether the replacement was successful or not. Failing to do so may result in malfunction and the new handset will need servicing.

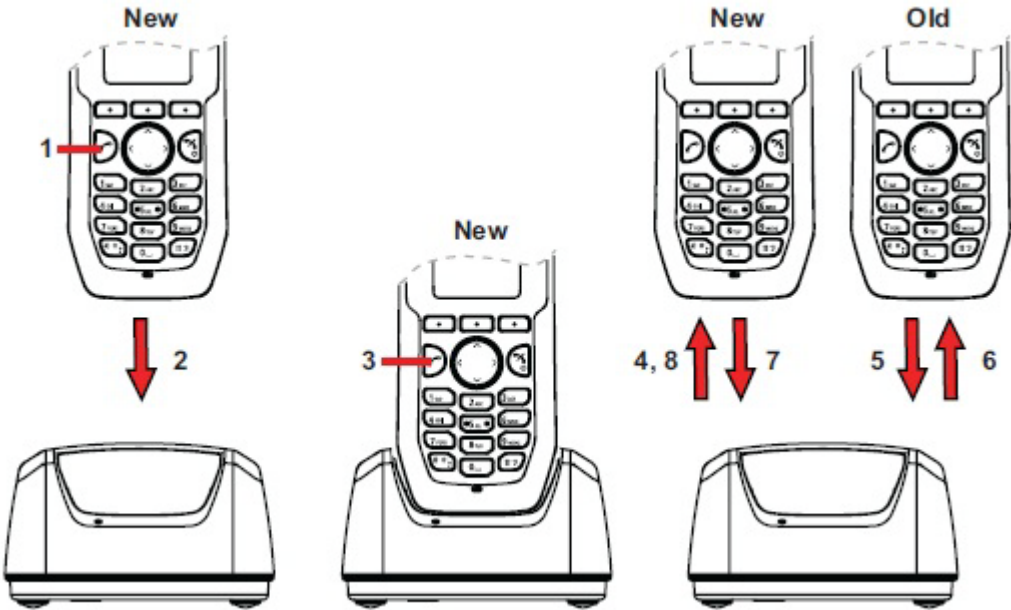





Figure 11: Easy Replacement using the 5624 Programmer

1	<p>On the new handset, press and hold </p> <p>Note: Do not release  until you are instructed to do so.</p>
2	Put the new handset in the charger.
3	<p>When the text "Start phone replacement?" appears, release  .</p> <p>Press "Yes" (left soft key).</p> <p>The text "Follow the instructions. Each step can take several minutes." appears.</p> <p>Press "OK"(left soft key).</p>
4, 5	<p>When the text "Please insert old phone in charger" appears, replace the new handset with the old handset. The handset can either be switched on or off.</p> <p>Note: If the rack charger is used, the same charging slot has to be used for both handsets.</p> <p>The handset will be restarted and after a few seconds.</p> <p>The text "Saving settings appears.</p> <p>Do not remove phone from charger" appears. The charger LED changes to slow orange flashing.</p> <p>IMPORTANT: Do not remove the handset while the text "Saving settings. Do not remove phone from charger" appears. It may take several minutes.</p>
6, 7	<p>When the text "Please insert new phone in charger" appears, replace the old handset with the new handset.</p> <p>The text "Restoring settings" appears.</p> <p>IMPORTANT: Do not remove the handset while the text "Restoring settings" appears</p>
8	When the text "Phone successfully replaced. Please remove phone to restart." appears, remove the handset from the charger. The handset is automatically restarted.

LED Indications during Easy Replacement

The following table shows the LED indications that are used for the 5624 and the charger during the easy replacement procedure.

LED indication	Description
Orange, flashing (1 000 ms on, 1 000 ms off)	File transfer during Easy Replacement
Orange, flashing (100 ms on, 800 ms off)	"Change phone" indication during Easy Replacement
Red, flashing (100 ms on, 800 ms off)	Error indication during Easy Replacement. Put back old handset in charger
Red, flashing (900 ms on, 100 ms off)	Error during Easy Replacement. Service required for <i>both</i> handsets

See the *Mitel 5624 Wireless Handset Configuration Guide*.

Attach the Hinge-type Clip

Attach the hinge-type belt clip as shown in the illustration below.

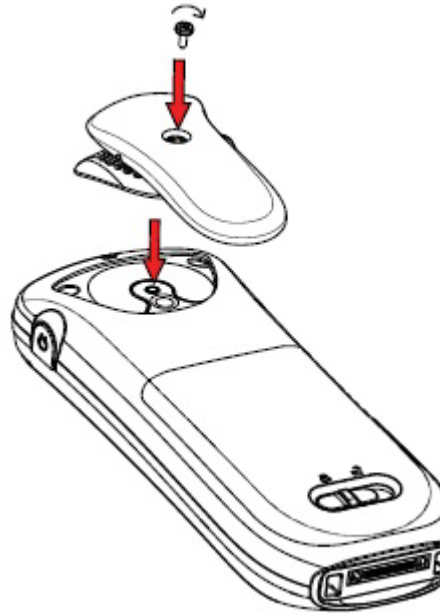

Figure 12: Screw the Hinge-type Clip into Position

Attach the Swivel-type Clip

Attach the swivel-type belt clip as shown in the illustration below.

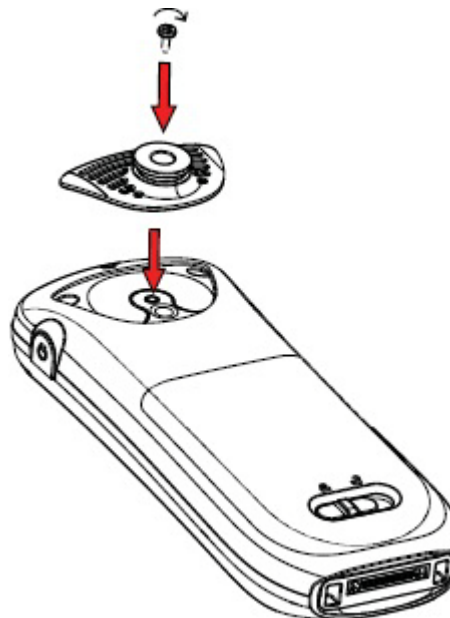

Figure 13: Screw the Swivel-type Clip into Position

Attach a Cover without a Clip

Attach the enclosed cover as shown in the illustration below when no clip is to be used.

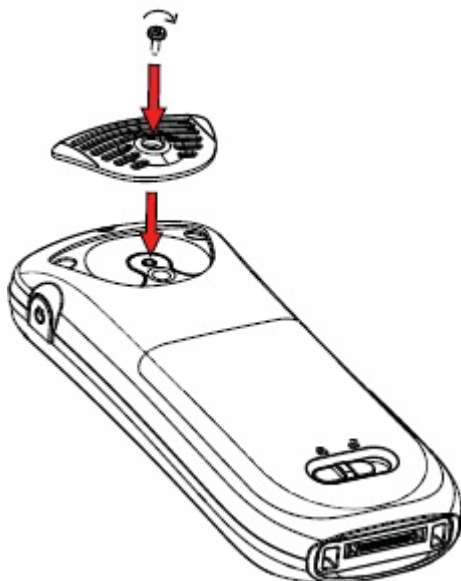

Figure 14: Screw the Cover into Position

Related Documents

- Mitel 5624 WiFi Handset Datasheet
- Mitel 5624 Wireless Handset User Guide
- Mitel 5624 Wireless Handset Quick Reference Guide
- Mitel 5624 Wireless Handset Configuration Guide
- Portable Device Manager, Windows Version, Installation and Operation Guide
- WSM3 Installation and Operation Guide

Index

NUMERIC

3rd party 10

A

Antenna 3

B

Battery 3, 71
low battery 8, 71

C

C (Clear) button 11
Call info 10
Call service 10
Calling
answered call 9
call a number from the call list 17
dial a number 17
missed call 9
outgoing call 9
quick call by a name in the phonebook 17–18
Case 3
Centralized phonebook 59
Chemical resistance 7
Clip 3

D

Delete a Text Message 28

E

Earpiece 3
Easy replacement 72

F

Forward a Text Message 28

H

Handsfree key 1
Headset connector 1

I

Icons 8

L

LED indications 74
Loudspeaker 3
Loudspeaking 8, 19

M

Menu tabs 9
Message
new message 8, 27
old message 8
voice message 8
Microphone 3
Mute button 11

N

Navigation Key 11
Number input mode 13

O

On/Off button 11
Ongoing call 10
Operating Area 70
Out of Coverage 70

P

PIN code 63
Push to Talk 50

R

Reply to a Text Message 28
Ring signal muted 8

S

Signal strength 8
Standby mode
date 7
time 7
user identity 7

T

Text input mode 13

W

Writing Text/Numbers
add space in text 13
pause 13
upper/lower case 13

Fax: +1(613) 592-4784 Fax: +1(480) 961-1370 Fax: +44(0)1291-430400 Fax: +1(613) 592-7825 Fax: +61(0) 2 9023 9501

mitel.com



FOR MORE INFORMATION ON OUR WORLDWIDE OFFICE LOCATIONS, VISIT OUR WEBSITE AT MITEL.COM/OFFICES

THIS DOCUMENT IS PROVIDED TO YOU FOR INFORMATIONAL PURPOSES ONLY. The information furnished in this document, believed by Mitel to be accurate as of the date of its publication, is subject to change without notice. Mitel assumes no responsibility for any errors or omissions in this document and shall have no obligation to you as a result of having made this document available to you or based upon the information it contains.

M MITEL (design) is a registered trademark of Mitel Networks Corporation. All other products and services are the registered trademarks of their respective holders.

© Copyright 2012, Mitel Networks Corporation. All Rights Reserved.