

DAQ

DAQCard™ -1200 User Manual

Multifunction I/O Card for
the PCMCIA Bus

Worldwide Technical Support and Product Information

www.natinst.com

National Instruments Corporate Headquarters

11500 North Mopac Expressway Austin, Texas 78759-3504 USA Tel: 512 794 0100

Worldwide Offices

Australia 03 9879 5166, Austria 0662 45 79 90 0, Belgium 02 757 00 20, Brazil 011 284 5011,
Canada (Calgary) 403 274 9391, Canada (Ontario) 905 785 0085, Canada (Québec) 514 694 8521,
China 0755 3904939, Denmark 45 76 26 00, Finland 09 725 725 11, France 01 48 14 24 24,
Germany 089 741 31 30, Greece 30 1 42 96 427, Hong Kong 2645 3186, India 91805275406,
Israel 03 6120092, Italy 02 413091, Japan 03 5472 2970, Korea 02 596 7456, Mexico (D.F.) 5 280 7625,
Mexico (Monterrey) 8 357 7695, Netherlands 0348 433466, Norway 32 27 73 00, Singapore 2265886,
Spain (Barcelona) 93 582 0251, Spain (Madrid) 91 640 0085, Sweden 08 587 895 00,
Switzerland 056 200 51 51, Taiwan 02 2377 1200, United Kingdom 01635 523545

For further support information, see the *Technical Support Resources* appendix. To comment on the documentation, send e-mail to techpubs@natinst.com.

© Copyright 1995, 1999 National Instruments Corporation. All rights reserved.

Important Information

Warranty

The DAQ-Card-1200 is warranted against defects in materials and workmanship for a period of one year from the date of shipment, as evidenced by receipts or other documentation. National Instruments will, at its option, repair or replace equipment that proves to be defective during the warranty period. This warranty includes parts and labor.

The media on which you receive National Instruments software are warranted not to fail to execute programming instructions, due to defects in materials and workmanship, for a period of 90 days from date of shipment, as evidenced by receipts or other documentation. National Instruments will, at its option, repair or replace software media that do not execute programming instructions if National Instruments receives notice of such defects during the warranty period. National Instruments does not warrant that the operation of the software shall be uninterrupted or error free.

A Return Material Authorization (RMA) number must be obtained from the factory and clearly marked on the outside of the package before any equipment will be accepted for warranty work. National Instruments will pay the shipping costs of returning to the owner parts which are covered by warranty.

National Instruments believes that the information in this document is accurate. The document has been carefully reviewed for technical accuracy. In the event that technical or typographical errors exist, National Instruments reserves the right to make changes to subsequent editions of this document without prior notice to holders of this edition. The reader should consult National Instruments if errors are suspected. In no event shall National Instruments be liable for any damages arising out of or related to this document or the information contained in it.

EXCEPT AS SPECIFIED HEREIN, NATIONAL INSTRUMENTS MAKES NO WARRANTIES, EXPRESS OR IMPLIED, AND SPECIFICALLY DISCLAIMS ANY WARRANTY OF MERCHANTABILITY OR FITNESS FOR A PARTICULAR PURPOSE. CUSTOMER'S RIGHT TO RECOVER DAMAGES CAUSED BY FAULT OR NEGLIGENCE ON THE PART OF NATIONAL INSTRUMENTS SHALL BE LIMITED TO THE AMOUNT THEREFORE PAID BY THE CUSTOMER. NATIONAL INSTRUMENTS WILL NOT BE LIABLE FOR DAMAGES RESULTING FROM LOSS OF DATA, PROFITS, USE OF PRODUCTS, OR INCIDENTAL OR CONSEQUENTIAL DAMAGES, EVEN IF ADVISED OF THE POSSIBILITY THEREOF. This limitation of the liability of National Instruments will apply regardless of the form of action, whether in contract or tort, including negligence. Any action against National Instruments must be brought within one year after the cause of action accrues. National Instruments shall not be liable for any delay in performance due to causes beyond its reasonable control. The warranty provided herein does not cover damages, defects, malfunctions, or service failures caused by owner's failure to follow the National Instruments installation, operation, or maintenance instructions; owner's modification of the product; owner's abuse, misuse, or negligent acts; and power failure or surges, fire, flood, accident, actions of third parties, or other events outside reasonable control.

Copyright

Under the copyright laws, this publication may not be reproduced or transmitted in any form, electronic or mechanical, including photocopying, recording, storing in an information retrieval system, or translating, in whole or in part, without the prior written consent of National Instruments Corporation.

Trademarks

CVI™, DAQCard™, DAQPad™, LabVIEW™, natinst.com™, National Instruments™, NI-DAQ™, and RTSI™ are trademarks of National Instruments Corporation.

Product and company names mentioned herein are trademarks or trade names of their respective companies.

WARNING REGARDING USE OF NATIONAL INSTRUMENTS PRODUCTS

(1) NATIONAL INSTRUMENTS PRODUCTS ARE NOT DESIGNED WITH COMPONENTS AND TESTING FOR A LEVEL OF RELIABILITY SUITABLE FOR USE IN OR IN CONNECTION WITH SURGICAL IMPLANTS OR AS CRITICAL COMPONENTS IN ANY LIFE SUPPORT SYSTEMS WHOSE FAILURE TO PERFORM CAN REASONABLY BE EXPECTED TO CAUSE SIGNIFICANT INJURY TO A HUMAN.

(2) IN ANY APPLICATION, INCLUDING THE ABOVE, RELIABILITY OF OPERATION OF THE SOFTWARE PRODUCTS CAN BE IMPAIRED BY ADVERSE FACTORS, INCLUDING BUT NOT LIMITED TO FLUCTUATIONS IN ELECTRICAL POWER SUPPLY, COMPUTER HARDWARE MALFUNCTIONS, COMPUTER OPERATING SYSTEM SOFTWARE FITNESS, FITNESS OF COMPILERS AND DEVELOPMENT SOFTWARE USED TO DEVELOP AN APPLICATION, INSTALLATION ERRORS, SOFTWARE AND HARDWARE COMPATIBILITY PROBLEMS, MALFUNCTIONS OR FAILURES OF ELECTRONIC MONITORING OR CONTROL DEVICES, TRANSIENT FAILURES OF ELECTRONIC SYSTEMS (HARDWARE AND/OR SOFTWARE), UNANTICIPATED USES OR MISUSES, OR ERRORS ON THE PART OF THE USER OR APPLICATIONS DESIGNER (ADVERSE FACTORS SUCH AS THESE ARE HEREAFTER COLLECTIVELY TERMED "SYSTEM FAILURES"). ANY APPLICATION WHERE A SYSTEM FAILURE WOULD CREATE A RISK OF HARM TO PROPERTY OR PERSONS (INCLUDING THE RISK OF BODILY INJURY AND DEATH) SHOULD NOT BE RELIANT SOLELY UPON ONE FORM OF ELECTRONIC SYSTEM DUE TO THE RISK OF SYSTEM FAILURE. TO AVOID DAMAGE, INJURY, OR DEATH, THE USER OR APPLICATION DESIGNER MUST TAKE REASONABLY PRUDENT STEPS TO PROTECT AGAINST SYSTEM FAILURES, INCLUDING BUT NOT LIMITED TO BACK-UP OR SHUT DOWN MECHANISMS. BECAUSE EACH END-USER SYSTEM IS CUSTOMIZED AND DIFFERS FROM NATIONAL INSTRUMENTS' TESTING PLATFORMS AND BECAUSE A USER OR APPLICATION DESIGNER MAY USE NATIONAL INSTRUMENTS PRODUCTS IN COMBINATION WITH OTHER PRODUCTS IN A MANNER NOT EVALUATED OR CONTEMPLATED BY NATIONAL INSTRUMENTS, THE USER OR APPLICATION DESIGNER IS ULTIMATELY RESPONSIBLE FOR VERIFYING AND VALIDATING THE SUITABILITY OF NATIONAL INSTRUMENTS PRODUCTS WHENEVER NATIONAL INSTRUMENTS PRODUCTS ARE INCORPORATED IN A SYSTEM OR APPLICATION, INCLUDING, WITHOUT LIMITATION, THE APPROPRIATE DESIGN, PROCESS AND SAFETY LEVEL OF SUCH SYSTEM OR APPLICATION.

Contents

About This Manual

Organization of This Manual	ix
Conventions Used in This Manual	x
National Instruments Documentation	xi
Related Documentation	xii

Chapter 1

Introduction

About the DAQCard-1200	1-1
What You Need to Get Started	1-2
Software Programming Choices	1-2
LabVIEW and LabWindows/CVI Application Software	1-3
NI-DAQ Driver Software	1-3
Register-Level Programming	1-4
Optional Equipment	1-5
Unpacking	1-5

Chapter 2

Installation and Configuration

Installation	2-1
Configuration	2-2
Analog Input Configuration	2-3
Analog Input Polarity	2-3
Analog Input Mode	2-4
RSE Input (Eight Channels, Default Setting)	2-4
NRSE Input (Eight Channels)	2-5
DIFF Input (Four Channels)	2-5
Analog Output Configuration	2-5
Analog Output Polarity	2-6
Digital I/O Configuration	2-6
Counter Configuration	2-6

Chapter 3

Signal Connections

I/O Connector	3-1
Signal Connection Descriptions	3-3
Analog Input Signal Connections	3-4

Types of Signal Sources	3-6
Floating Signal Sources.....	3-6
Ground-Referenced Signal Sources	3-6
Input Configurations.....	3-7
Differential Connection Considerations	
(DIFF Configuration)	3-7
Differential Connections for Grounded Signal Sources.....	3-8
Differential Connections for Floating Signal Sources	3-9
Single-Ended Connection Considerations.....	3-11
Single-Ended Connections for Floating Signal Sources	
(RSE Configuration).....	3-11
Single-Ended Connections for Grounded Signal	
Sources (NRSE Configuration)	3-12
Common-Mode Signal Rejection Considerations.....	3-13
Analog Output Signal Connections.....	3-14
Digital I/O Signal Connections.....	3-15
Port C Pin Connections.....	3-17
Timing Specifications.....	3-18
Mode 1 Input Timing	3-19
Mode 1 Output Timing.....	3-20
Mode 2 Bidirectional Timing.....	3-20
DAQ and General-Purpose Timing Signal Connections	3-22
DAQ Timing Connections	3-22
General-Purpose Timing Signal Connections	3-26
Power Connections	3-31

Chapter 4

Theory of Operation

Functional Overview	4-1
PC Card I/O Channel Interface Circuitry	4-2
Timing	4-3
Analog Input.....	4-5
Analog Input Circuitry	4-6
Data Acquisition Timing.....	4-8
Data Acquisition Operation	4-8
Continuous Data Acquisition.....	4-8
Interval Data Acquisition.....	4-9
Data Acquisition Rates.....	4-9

Analog Output.....	4-11
Analog Output Circuitry.....	4-11
Power-On State.....	4-12
DAC Timing.....	4-12
Digital I/O.....	4-13

Chapter 5 Calibration

Calibration at Higher Gains.....	5-2
Calibration Equipment Requirements.....	5-2
Using the Calibration Function.....	5-2

Appendix A Specifications

Appendix B Differences among the Lab-PC+, the DAQPad-1200, and the DAQCard-1200

Appendix C Power-Management Modes

Appendix D PC Card Questions and Answers

Appendix E Technical Support Resources

Glossary

Index

Figures

Figure 1-1. The Relationship between the Programming Environment, NI-DAQ, and Your Hardware.....	1-4
Figure 2-1. A Typical Configuration for the DAQCard-1200.....	2-2

Figure 3-1.	DAQCard-1200 I/O Connector Pin Assignments.....	3-2
Figure 3-2.	DAQCard-1200 Instrumentation Amplifier.....	3-5
Figure 3-3.	Differential Input Connections for Grounded Signal Sources.....	3-9
Figure 3-4.	Differential Input Connections for Floating Sources.....	3-10
Figure 3-5.	Single-Ended Input Connections for Floating Signal Sources.....	3-12
Figure 3-6.	Single-Ended Input Connections for Grounded Signal Sources.....	3-13
Figure 3-7.	Analog Output Signal Connections.....	3-14
Figure 3-8.	Digital I/O Connections.....	3-16
Figure 3-9.	Mode 1 Timing Specifications for Input Transfers.....	3-19
Figure 3-10.	Mode 1 Timing Specifications for Output Transfers.....	3-20
Figure 3-11.	Mode 2 Timing Specifications for Bidirectional Transfers.....	3-21
Figure 3-12.	EXTCONV* Signal Timing.....	3-22
Figure 3-13.	Posttrigger DAQ Timing.....	3-23
Figure 3-14.	Pretrigger DAQ Timing.....	3-24
Figure 3-15.	Interval-Scanning Signal Timing.....	3-25
Figure 3-16.	EXTUPDATE* Signal Timing for Updating DAC Output.....	3-26
Figure 3-17.	Event-Counting Application with External Switch Gating.....	3-27
Figure 3-18.	Frequency Measurement Application.....	3-29
Figure 3-19.	General-Purpose Timing Signals.....	3-30
Figure 4-1.	DAQCard-1200 Block Diagram.....	4-1
Figure 4-2.	PC Card I/O Interface Circuitry Block Diagram.....	4-2
Figure 4-3.	Timing Circuitry.....	4-4
Figure 4-4.	Analog Input Circuitry.....	4-6
Figure 4-5.	Analog Output Circuitry.....	4-11
Figure 4-6.	Digital I/O Circuitry.....	4-13

Tables

Table 2-1.	Analog I/O Settings.....	2-3
Table 2-2.	Analog Input Modes for the DAQCard-1200.....	2-4
Table 3-1.	Bipolar and Unipolar Analog Input Signal Range Versus Gain.....	3-5
Table 3-2.	Recommended Input Configurations for Ground-Referenced and Floating Signal Sources.....	3-7
Table 3-3.	Port C Signal Assignments.....	3-17
Table 4-1.	Analog Input Settling Time Versus Gain.....	4-10
Table 4-2.	DAQCard-1200 Maximum Recommended Data Acquisition Rates....	4-10
Table C-1.	DAQCard-1200 Power-Management Modes.....	C-1

About This Manual

This manual describes the mechanical and electrical aspects of the DAQCard-1200 and contains information concerning its installation and operation. The DAQCard-1200 is a compact, low-cost, low-power analog input, analog output, digital, and timing I/O card for IBM PC/XT, PC AT, and compatible computers that are equipped with a Type II PC Card socket.

Organization of This Manual

The *DAQCard-1200 User Manual* is organized as follows:

- Chapter 1, *Introduction*, describes the DAQCard-1200; lists what you need to get started, the optional software, and optional equipment; and explains how to unpack the DAQCard-1200.
- Chapter 2, *Installation and Configuration*, describes how to install and software configure the DAQCard-1200.
- Chapter 3, *Signal Connections*, describes the signals on the DAQCard-1200 I/O connector.
- Chapter 4, *Theory of Operation*, explains the operation of each functional unit of the DAQCard-1200.
- Chapter 5, *Calibration*, discusses the calibration procedures for the DAQCard-1200 analog I/O circuitry.
- Appendix A, *Specifications*, lists the specifications of the DAQCard-1200.
- Appendix B, *Differences among the Lab-PC+, the DAQPad-1200, and the DAQCard-1200*, contains a summary of the functional differences among the Lab-PC+, the DAQPad-1200, and the DAQCard-1200.
- Appendix C, *Power-Management Modes*, describes the power-management modes of the DAQCard-1200.
- Appendix D, *PC Card Questions and Answers*, contains a list of common questions and answers relating to PC Card operation.
- Appendix E, *Technical Support Resources*, contains forms you can use to request help from National Instruments or to comment on our products and manuals.

- The *Glossary* contains an alphabetical list and description of terms used in this manual, including abbreviations, acronyms, metric prefixes, mnemonics, and symbols.
- The *Index* contains an alphabetical list of key terms and topics in this manual, including the page where you can find each one.

Conventions Used in This Manual

The following conventions are used in this manual:

<>

Angle brackets enclose the name of a key on the keyboard—for example, <shift>. Angle brackets containing numbers separated by an ellipsis represent a range of values associated with a bit or signal name—for example, DBIO<3..0>.



This icon to the left of bold italicized text denotes a note, which alerts you to important information.



This icon to the left of bold italicized text denotes a caution, which advises you of precautions to take to avoid injury, data loss, or a system crash.



This icon to the left of bold italicized text denotes a warning, which advises you of precautions to take to avoid being electrically shocked.

bold italic

Bold italic text denotes an activity objective, note, caution, or warning.

italic

Italic text denotes variables, emphasis, a cross reference, or an introduction to a key concept. This font also denotes text from which you supply the appropriate word or value, as in NI-DAQ 6.x.

monospace

Text in this font denotes text or characters that you should literally enter from the keyboard, sections of code, programming examples, and syntax examples. This font is also used for the proper names of disk drives, paths, directories, programs, subprograms, subroutines, device names, functions, operations, variables, file names and extensions, and for statements and comments taken from programs.

NI-DAQ

NI-DAQ is used in this manual to refer to the NI-DAQ software for PC compatibles unless otherwise stated.

PC

PC refers to the IBM PC/XT, PC AT, Personal System/2, and laptop compatible computers which are equipped with a Type II, 5 V-capable slot and a PCMCIA standard version 2.0 or later bus interface.

National Instruments Documentation

The *DAQCard-1200 User Manual* is one piece of the documentation set for your data acquisition system. You could have any of several types of manuals, depending on the hardware and software in your system. Use the manuals you have as follows:

- *Getting Started with SCXI*—If you are using SCXI, this is the first manual you should read. It gives an overview of the SCXI system and contains the most commonly needed information for the modules, chassis, and software.
- Your SCXI user manuals—If you are using SCXI, read these manuals next for detailed information about signal connections and module configuration. They also explain in greater detail how the module works and contain application hints.
- Your DAQ board user manuals—These manuals have detailed information about the DAQ hardware that plugs into or is connected to your computer. Use these manuals for hardware installation and configuration instructions, specification information about your DAQ hardware, and application hints.
- Software manuals—Examples of software manuals you may have are the LabVIEW and LabWindows/CVI manual sets and the NI-DAQ manuals. After you set up your hardware system, use either the application software (LabVIEW or LabWindows/CVI) manuals or the NI-DAQ manuals to help you write your application. If you have a large and complicated system, it is worthwhile to look through the software manuals before you configure your hardware.
- Accessory manuals—If you are using accessory products, read the terminal block and cable assembly installation guides. They explain how to physically connect the relevant pieces of the system. Consult these guides when you are making your connections.
- SCXI chassis manuals—If you are using SCXI, read these manuals for maintenance information on the chassis and installation instructions.

Related Documentation

The following documents contain information that you may find helpful as you read this manual:

- Your NI-DAQ or LabVIEW software manuals for PC compatibles
- Your computer operating manual, which explains how to insert cards into the PC Card slot
- “Dither in Digital Audio” by John Vanderkooy and Stanley P. Lipshitz, *Journal of the Audio Engineering Society*, Vol. 35, No. 12, Dec. 1987

Introduction

This chapter describes the DAQCard-1200; lists what you need to get started, the optional software, and optional equipment; and explains how to unpack the DAQCard-1200.

About the DAQCard-1200

Thank you for your purchase of the National Instruments DAQCard-1200. The DAQCard-1200 is a low-cost, low-power analog input, analog output, digital I/O, and timing I/O card for PCs equipped with a Type II PC Card slot. The card contains a 12-bit, successive-approximation ADC with eight inputs, which you can configure as eight single-ended or four differential channels. The DAQCard-1200 also has two 12-bit DACs with voltage outputs, 24 lines of TTL-compatible digital I/O and three 16-bit counter/timer channels for timing I/O. The specially designed standard 50-pin I/O connector for the DAQCard-1200 enables you to connect all your analog, digital, and timing signals directly to the card. The DAQCard-1200 is fully software-configurable and calibrated so that you can easily install the card and begin your acquisition.

The small size and weight of the DAQCard-1200 coupled with its low power consumption make this card ideal for use in portable computers, making portable data acquisition practical. The card requires very little power when operating, thus extending the life of your computer batteries.

In addition, the low cost and multifunctional nature of a system based on the DAQCard-1200 makes it ideal for laboratory work in industrial and academic environments. The multichannel analog input is useful in signal analysis and data logging. The 12-bit ADC is useful in high-resolution applications such as chromatography, temperature measurement, and DC voltage measurement. You can use the analog output channels to generate experimental stimuli or for machine and process control and analog function generation. You can use the 24 TTL-compatible digital I/O line for switching external devices such as transistors and solid-state relays, for reading the status of external digital logic, and for generating interrupts. You can use the counter/timers to synchronize events, generate pulses, and measure frequency and time. The DAQCard-1200, used in conjunction

with the PC, is a versatile, cost-effective and portable platform for laboratory test, measurement, and control.

The DAQCard-1200 is shipped with NI-DAQ, a National Instruments complete DAQ driver that handles every function listed on the data sheet for our DAQ hardware. Using NI-DAQ, you can start your application quickly and easily without having to program the card at the register level. Utilities shipped with NI-DAQ also can help you conserve additional power by configuring the DAQCard-1200 in the power-down mode. See Appendix C, [Power-Management Modes](#), for a description of the power-management modes.

Detailed specifications of the DAQCard-1200 are in Appendix A, [Specifications](#).

What You Need to Get Started

To set up and use your DAQCard-1200, you will need the following items:

- DAQCard-1200
- DAQCard-1200 I/O cable
- DAQCard-1200 User Manual
- One of the following software packages and documentation:
 - LabVIEW for Macintosh
 - LabVIEW for Windows
 - LabWindows/CVI for Windows
 - NI-DAQ for Macintosh
 - NI-DAQ for PC compatibles
- Your computer

Software Programming Choices

There are several options to choose from when programming your National Instruments plug-in DAQ and SCXI hardware. You can use LabVIEW, LabWindows/CVI, or NI-DAQ.

LabVIEW and LabWindows/CVI Application Software

LabVIEW and LabWindows/CVI are innovative program development software packages for data acquisition and control applications. LabVIEW uses graphical programming, whereas LabWindows/CVI enhances traditional programming languages. Both packages include extensive libraries for data acquisition, instrument control, data analysis, and graphical data presentation.

LabVIEW features interactive graphics, a state-of-the-art user interface, and a powerful graphical programming language. The LabVIEW Data Acquisition VI Library, a series of VIs for using LabVIEW with National Instruments boards, is included with LabVIEW. The LabVIEW Data Acquisition VI Libraries are functionally equivalent to the NI-DAQ software.

LabWindows/CVI features interactive graphics and a state-of-the-art user interface and uses the ANSI standard C programming language. The LabWindows/CVI Data Acquisition Library, a series of functions for using LabWindows/CVI with National Instruments boards, is included with your NI-DAQ software kit. The LabWindows/CVI Data Acquisition libraries are functionally equivalent to the NI-DAQ software.

Using LabVIEW or LabWindows/CVI software will greatly reduce the development time for your data acquisition and control application.

NI-DAQ Driver Software

The NI-DAQ driver software is included at no charge with all National Instruments DAQ hardware. NI-DAQ has an extensive library of functions that you can call from your application programming environment. These functions include routines for analog input (A/D conversion), buffered data acquisition (high-speed A/D conversion), analog output (D/A conversion), waveform generation, digital I/O, counter/timer operations, SCXI, RTSI, self-calibration, messaging, and acquiring data to extended memory.

NI-DAQ also internally addresses many of the complex issues between the computer and the plug-in board, such as programming interrupts and DMA controllers. NI-DAQ maintains a consistent software interface among its different versions so that you can change platforms with minimal modifications to your code. Figure 1-1 illustrates the relationship between NI-DAQ and LabVIEW and LabWindows/CVI. You can see that the data acquisition parts of LabVIEW and LabWindows/CVI are functionally equivalent to the NI-DAQ software.

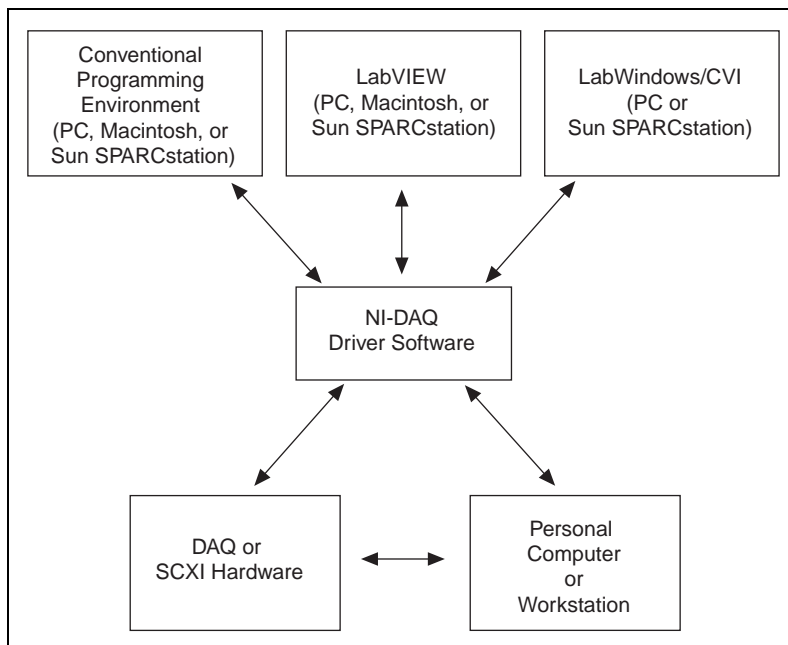

Figure 1-1. The Relationship between the Programming Environment, NI-DAQ, and Your Hardware

Register-Level Programming

The final option for programming any National Instruments DAQ hardware is to write register-level software. Writing register-level programming software can be very time-consuming and inefficient and is not recommended.

Even if you are an experienced register-level programmer, consider using NI-DAQ, LabVIEW, or LabWindows/CVI to program your National Instruments DAQ hardware. Using the NI-DAQ, LabVIEW, or LabWindows/CVI software is as easy and as flexible as register-level programming and can save weeks of development time.

Optional Equipment

You can use the following National Instruments products with your DAQCard-1200:

- BNC-2081
- CB-50 or CB-50LP I/O connector block with a 0.5 or 1.0 m cable
- ER-8, ER-16 electromechanical relays
- PR50-50F or PR50-50M cables
- SC-2042, SC-2043 strain gauge and RTD accessories
- SCXI products

For more information about optional equipment available from National Instruments, refer to your National Instruments catalog or call the office nearest you.

Unpacking

The DAQCard-1200 is shipped in an antistatic vinyl envelope; when you are not using the DAQCard-1200, store it in this envelope.

Because the DAQCard-1200 is enclosed in a fully shielded case, no additional electrostatic precautions are necessary. However, for your own safety and to protect the DAQCard-1200, never attempt to touch the pins of the connectors.

Installation and Configuration

This chapter describes how to install and software configure the DAQCard-1200.

Installation

There are two basic steps to installing the DAQCard-1200.

1. You must have Card & Socket Services 2.0 (or a later version) on your computer.
2. Insert the DAQCard-1200 and attach the I/O cable.

The DAQCard-1200 has two connectors—a 68-pin PCMCIA bus connector on one end and a 50-pin I/O connector on the other end. Insert the PCMCIA bus connector into any available Type II PC Card slot until the connector is seated firmly. Notice that the card is keyed so that it can be inserted only one way. If your computer supports hot insertion, you may insert or remove the DAQCard-1200 at any time, whether your computer is powered on or off.

You can use either a 50-pin female or a 50-pin male cable to plug into the DAQCard-1200. For more information on these products, see the *Optional Equipment* section in Chapter 1, *Introduction*. Notice that the cable is keyed so that you can insert it only one way. Be careful not to put strain on the I/O cable when inserting it into and removing it from the DAQCard-1200. Always grasp the cable by the connector you are plugging or unplugging. *Never* pull directly on the I/O cable to unplug it from the DAQCard-1200.

The DAQCard-1200 is now installed. You are ready to make the appropriate connections to the I/O connector cable as described in Chapter 3, *Signal Connections*, and to install and configure your software.

Figure 2-1 shows an example of a typical configuration.

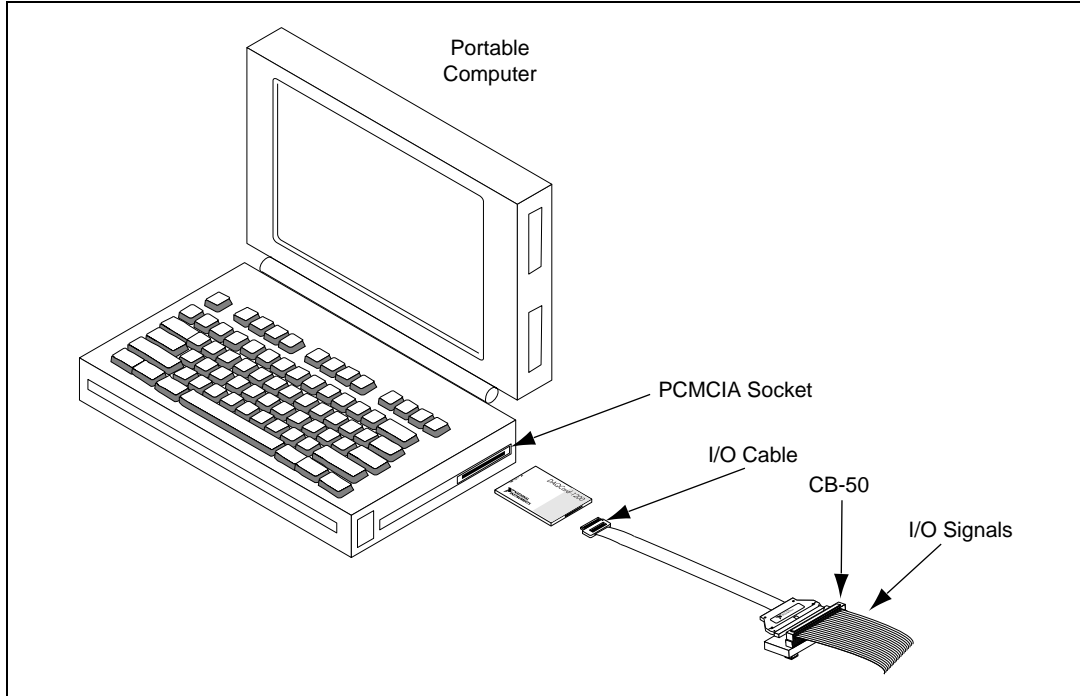

Figure 2-1. A Typical Configuration for the DAQCard-1200

Configuration

The DAQCard-1200 is completely software configurable; refer to your software manuals to install and configure your software.

If you are using NI-DAQ, refer to your NI-DAQ user manual or function reference manual. The software installation and configuration instructions are in Chapter 1. Find the installation and system configuration section for your operating system and follow the instructions given there.

If you are using LabVIEW, you do not need the NI-DAQ manuals; the software installation instructions are in your LabVIEW release notes. After you have installed LabVIEW, refer to the *Data Acquisition, VXI, and GPIB Installation Notes* section of Chapter 1, *Required Configuration, Installation, and Upgrade Information* of your *LabVIEW Version 5.1 Addendum* for software configuration instructions.

If you are using LabWindows/CVI, the software installation instructions are in Part 1, *Introduction to LabWindows/CVI*, of the *Getting Started with LabWindows/CVI* manual. After you have installed LabWindows/CVI, refer to Chapter 1, *Configuring LabWindows/CVI*, of the *LabWindows/CVI User Manual* for software configuration instructions. Then follow DAQ configuration instructions in your NI-DAQ user manual.

Analog Input Configuration

At startup, the DAQCard-1200 defaults to the following configuration:

- Referenced single-ended input mode
- ± 5 V analog input range

Table 2-1 lists the available analog I/O configurations for the DAQCard-1200 and shows the default settings.

Table 2-1. Analog I/O Settings

Parameter	Configuration
Analog Input Polarity	Bipolar— ± 5 V (default setting) Unipolar—0–10 V
Analog Input Mode	Referenced single-ended (RSE) (default setting) Non-referenced single-ended (NRSE) Differential (DIFF)

The analog input circuitry is software configurable.



Warning *Connections, including power signals to ground and vice versa, that exceed any of the maximum signal ratings on the DAQCard-1200 can damage your card and computer. National Instruments is NOT liable for any damages or injuries resulting from incorrect signal connections.*

Analog Input Polarity

You can select the analog input on the DAQCard-1200 for either a unipolar range (0 to 10 V) or a bipolar range (-5 to $+5$ V). If you select a bipolar range, the two's complement coding is selected. In this mode, -5 V input corresponds to F800 hex ($-2,048$ decimal) and $+5$ V corresponds to 7FF hex ($2,047$ decimal). If you select a unipolar mode, the straight binary coding is selected. In this mode, 0 V input corresponds to 0 hex, and $+10$ V corresponds to FFF hex ($4,095$ decimal).

Analog Input Mode

The DAQCard-1200 has three different input modes—referenced single-ended (RSE), non-referenced single-ended (NRSE), and differential (DIFF). Single-ended configuration provides eight input channels. DIFF configuration provides four input channels. Table 2-2 describes these configurations.

Table 2-2. Analog Input Modes for the DAQCard-1200

Analog Input Modes	Description
RSE	Referenced single-ended mode provides eight single-ended inputs with the negative input of the instrumentation amplifier referenced to AISENSE/AIGND, which is tied to ground through about 200 Ω resistance (default setting).
NRSE	Non-referenced single-ended configuration provides eight single-ended inputs with the negative input of the instrumentation amplifier tied to AISENSE/AIGND and not connected to ground.
DIFF	Differential mode provides four differential inputs with the positive input of the instrumentation amplifier tied to channels 0, 2, 4, or 6 and the negative input tied to channels 1, 3, 5, or 7, respectively, thus pairing channels (0, 1), (2,3), (4,5), (6,7).

While reading the following paragraphs, you may find it helpful to refer to the [Analog Input Signal Connections](#) section of Chapter 3, [Signal Connections](#), which contains diagrams showing the signal paths for the three configurations. These three modes are software selectable.

RSE Input (Eight Channels, Default Setting)

RSE input means that all input signals are referenced to a common ground point that is also tied to the DAQCard-1200 analog input ground. The RSE configuration is useful for measuring floating signal sources. See the [Types of Signal Sources](#) section of Chapter 3, [Signal Connections](#), for more information. With the RSE configuration, the DAQCard-1200 can monitor eight different analog input channels.

Considerations for using the RSE configuration are discussed in Chapter 3, [Signal Connections](#). Notice that in RSE mode, the return path of the signal is through analog ground at the connector through the AISENSE/AIGND pin.

NRSE Input (Eight Channels)

NRSE input means that all signals are referenced to the same common mode voltage, which is allowed to float with respect to the analog ground of the DAQCard-1200. This common mode voltage is subsequently subtracted out by the instrumentation amplifier. NRSE configuration is useful when measuring ground-referenced signal sources.

Considerations in using the NRSE configuration are discussed in Chapter 3, *Signal Connections*. Notice that in this mode, the return path of the signal is through the negative terminal of the amplifier, available at the connector through the pin AISENSE/AIGND.

DIFF Input (Four Channels)

DIFF input means that each input signal has its own reference, and the difference between each signal and its reference is measured. The signal and its reference are each assigned an input channel. With DIFF input configuration, the DAQCard-1200 can monitor four different analog input signals.

Considerations for using the DIFF configuration are discussed in Chapter 3, *Signal Connections*. Notice that the signal return path is through the negative terminal of the instrumentation amplifier and through channel 1, 3, 5, or 7 depending on which channel pair you select.

Analog Output Configuration

You can set the analog output on the DAQCard-1200 to either bipolar or unipolar configurations.

Parameter	Configuration
Analog Output CH0 Polarity	Bipolar— ± 5 V (default setting) Unipolar—0–10 V
Analog Output CH1 Polarity	Bipolar— ± 5 V (default setting) Unipolar—0–10 V

Analog Output Polarity

The DAQCard-1200 has two channels of analog output voltage at the front panel I/O connector. You can configure each analog output channel for either unipolar or bipolar output. A unipolar configuration has a range of 0 to 10 V at the analog output. A bipolar configuration has a range of –5 to +5 V at the analog output. If you select a bipolar range for a D/A conversion (DAC), the two's complement coding is selected. In this mode, data values written to the analog output channel range from F800 hex (–2,048 decimal) to 7FF hex (2,047 decimal). If you select a unipolar range for a DAC, you are selecting the straight binary coding. In this mode, data values written to the analog output channel range from 0 to FFF hex (4,095 decimal).

Digital I/O Configuration

The DAQCard-1200 uses the MSM82C55 programmable peripheral interface (PPI). This chip provides 24 digital lines in the form of three ports—A, B, and C. On power up, all three ports reset to high impedance inputs. For information about configuring the MSM82C55, see the [DAQ Timing Connections](#) section of Chapter 3, [Signal Connections](#).



Caution *The DAQCard-1200 DIO lines are not pulled up or pulled down. If you are using these lines as digital outputs, add 10 k Ω resistors to +5 V or DGND (depending on your application) to the DIO line(s) you are using.*

Counter Configuration

You can use the MSM82C53A counter/timers for general-purpose timing applications, such as pulse and square wave generation, event counting, and pulse-width, time-lapse, and frequency measurement. For information about configuring the MSM82C53A, see the [DAQ Timing Connections](#) section of Chapter 3, [Signal Connections](#).

Signal Connections

This chapter describes the signals on the DAQCard-1200 I/O connector.

I/O Connector

Figure 3-1 shows the pin assignments for the DAQCard-1200 I/O connector. This connector is attached to the ribbon cable that extends from the PC Card slot when the card is installed and the cable connected.



Warning *Connections, including power signals to ground and vice versa, that exceed any of the maximum ratings of input or output signals on the DAQCard-1200 can damage the DAQCard-1200 and the PC. National Instruments is not liable for any damages resulting from any such signal connections.*

ACH0	1	2	ACH1
ACH2	3	4	ACH3
ACH4	5	6	ACH5
ACH6	7	8	ACH7
AISENSE/AIGND	9	10	DAC0OUT
AGND	11	12	DAC1OUT
DGND	13	14	PA0
PA1	15	16	PA2
PA3	17	18	PA4
PA5	19	20	PA6
PA7	21	22	PB0
PB1	23	24	PB2
PB3	25	26	PB4
PB5	27	28	PB6
PB7	29	30	PC0
PC1	31	32	PC2
PC3	33	34	PC4
PC5	35	36	PC6
PC7	37	38	EXTTRIG
EXTUPDATE*	39	40	EXTCONV*
OUTB0	41	42	GATB0
OUTB1	43	44	GATB1
CLKB1	45	46	OUTB2
GATB2	47	48	CLKB2
+5 V	49	50	DGND

Figure 3-1. DAQCard-1200 I/O Connector Pin Assignments

Signal Connection Descriptions

The following table describes the connector pins on the DAQCard-1200 front I/O connector by pin number and gives the signal name and the significance of each signal connector pin.

Pins	Signal Name	Direction	Reference	Description
1–8	ACH<0..7>	AI	AGND	Analog Channel 0 through 7—Analog input channels 0 through 7.
9	AISENSE/AIGND	AI	AGND	Analog Input Sense/Analog Input Ground—Connected to AGND in RSE mode, analog input sense in NRSE mode.
10	DAC0OUT	AO	AGND	DAC0 Output—Voltage output signal for analog output channel 0.
11	AGND	N/A	N/A	Analog Ground—Analog output ground reference for analog output voltages. This signal is the bias current return point for differential measurements.
12	DAC1OUT	AO	AGND	DAC1 Output—Voltage output signal for analog output channel 1.
13	DGND	N/A	N/A	Digital Ground—Voltage ground reference for the digital signals and the +5 V supply.
14–21	PA<0..7>	DIO	DGND	Port A 0 through 7—Bidirectional data lines for port A. PA7 is the MSB, and PA0 is the LSB.
22–29	PB<0..7>	DIO	DGND	Port B 0 through 7—Bidirectional data lines for port B. PB7 is the MSB, and PB0 is the LSB.
30–37	PC<0..7>	DIO	DGND	Port C 0 through 7—Bidirectional data lines for port C. PC7 is the MSB, and PC0 is the LSB.
38	EXTTRIG	DI	DGND	External Trigger—External control signal to trigger a DAQ operation.
39	EXTUPDATE*	DI	DGND	External Update—External control signal to update DAC outputs.
40	EXTCONV*	DIO	DGND	External Convert—External control signal to time A/D conversions (DI) and drive SCANCLK when you use SCXI (DO).
41	OUTB0	DO	DGND	Output B0—Voltage output signal of counter B0.
42	GATB0	DI	DGND	Gate B0—External control signal for gating counter B0.
43	OUTB1	DIO	DGND	Output B1—Voltage output signal of counter B1 when selected as output (DO). This is the external control signal for timing an interval cycle when selected as input (DI).
44	GATB1	DI	DGND	Gate B1—External control signal for gating counter B1.

Pins	Signal Name	Direction	Reference	Description
45	CLKB1	DI	DGND	Clock B1—External control clock signal for counter B1.
46	OUTB2	DO	DGND	Counter B2—Voltage output signal of counter B2.
47	GATB2	DI	DGND	Gate B2—External control signal for gating counter B2.
48	CLKB2	DI	DGND	Clock B2—External control clock signal for counter B2.
49	+5 V	DO	DGND	+5 Volts—Fused for up to 1 A of +5 V supply, but limit current to 250 mA.
50	DGND	N/A	N/A	Digital Ground—Voltage ground reference for the digital signals and the +5 V supply.

*Indicates that the signal is active low.
 AI = Analog Input DI = Digital Input DIO = Digital Input/Output
 AO = Analog Output DO = Digital Output N/A = Not Applicable

The connector pins are grouped into analog input signal pins, analog output signal pins, digital I/O signal pins, timing I/O signal pins, and power connections. Signal connection guidelines for each of these groups are described in the following sections.

Analog Input Signal Connections

Pins 1 through 8 are analog input signal pins for the 12-bit ADC. Pin 9, AISENSE/AIGND, is an analog common signal. You can use this pin as a signal ground connection to the DAQCard-1200 in RSE mode, or as a return path in NRSE mode. Pin 11, AGND, is the bias current return point for differential measurements. Pins 1 through 8 are tied, through 4.7 k Ω series resistances, to the eight single-ended analog input channels of the input multiplexer. Pins 2, 4, 6, and 8 are also tied to an input multiplexer for DIFF mode.

The signal ranges for inputs ACH<0..7> at all possible gains are shown in Table 3-1. Exceeding the input signal range will not damage the input circuitry as long as the maximum input voltage rating of ± 35 V powered on and ± 25 V powered off is not exceeded. The DAQCard-1200 is guaranteed to withstand inputs up to the maximum input voltage rating.



Warning *Exceeding the input signal range distorts input signals. Exceeding the maximum input voltage rating may damage the DAQCard-1200 and the computer. National Instruments is NOT liable for any damages resulting from such signal connections.*

Table 3-1. Bipolar and Unipolar Analog Input Signal Range Versus Gain

Gain Setting	Input Signal Range	
	Bipolar	Unipolar
1	± 5 V	0 to 10 V
2	± 2.5 V	0 to 5 V
5	± 1 V	0 to 2 V
10	± 500 mV	0 to 1 V
20	± 250 mV	0 to 500 mV
50	± 100 mV	0 to 200 mV
100	± 50 mV	0 to 100 mV

How you connect analog input signals to the DAQCard-1200 depends on how you configure the card analog input circuitry and the type of input signal source. With different DAQCard-1200 configurations, you can use the instrumentation amplifier in different ways. Figure 3-2 shows a diagram of the DAQCard-1200 instrumentation amplifier.

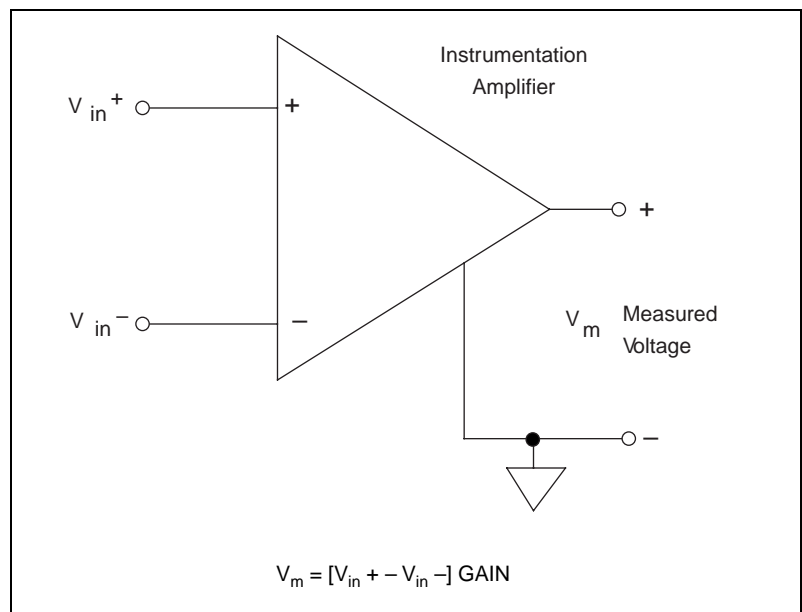
**Figure 3-2.** DAQCard-1200 Instrumentation Amplifier

The instrumentation amplifier applies gain, common-mode voltage rejection, and high-input impedance to the analog input signals connected to the DAQCard-1200. Signals are routed to the positive and negative inputs of the instrumentation amplifier through input multiplexers on the DAQCard-1200. The instrumentation amplifier converts two input signals to a signal that is the difference between the two input signals multiplied by the gain setting of the amplifier. The amplifier output voltage is referenced to the DAQCard-1200 ground. The DAQCard-1200 ADC measures this output voltage when it performs A/D conversions.

All signals must be referenced to ground, either at the source device or at the DAQCard-1200. If you have a floating source, you must use a ground-referenced input connection at the DAQCard-1200. If you have a grounded source, you must use a nonreferenced input connection at the DAQCard-1200.

Types of Signal Sources

When configuring the input mode of the DAQCard-1200 and making signal connections, you must first determine whether the signal source is floating or ground referenced. This section describes these two types of signals.

Floating Signal Sources

A floating signal source is not connected in any way to the building ground system but has an isolated ground-reference point. Some examples of floating signal sources are outputs of transformers, thermocouples, battery-powered devices, optical isolator outputs, and isolation amplifiers. You must tie the ground reference of a floating signal to the DAQCard-1200 analog input ground to establish a local or onboard reference for the signal. Otherwise, the measured input signal varies or appears to float. An instrument or device that supplies an isolated output falls into the floating signal source category.

Ground-Referenced Signal Sources

A ground-referenced signal source is connected in some way to the building system ground and is therefore already connected to a common ground point with respect to the DAQCard-1200, assuming that the PC is plugged into the same power system. Nonisolated outputs of instruments and devices that plug into the building power system fall into this category.

The difference in ground potential between two instruments connected to the same building power system is typically between 1 mV and 100 mV but can be much higher if power distribution circuits are not properly connected. The connection instructions that follow for grounded signal sources eliminate this ground potential difference from the measured signal.

**Note**

If you power both the DAQCard-1200 and your PC with a floating power source, such as a battery, your system may be floating with respect to earth ground. In this case, treat all of your signal sources as floating sources.

Input Configurations

You can configure the DAQCard-1200 for one of three input modes—RSE, NRSE, or DIFF. The following sections discuss the use of single-ended and differential measurements, and considerations for measuring both floating and ground-referenced signal sources. Table 3-2 summarizes the recommended input configurations for both types of signal sources.

Table 3-2. Recommended Input Configurations for Ground-Referenced and Floating Signal Sources

Type of Signal	Recommended Input Configuration
Ground-Referenced (nonisolated outputs, plug-in instruments)	DIFF NRSE
Floating (batteries, thermocouples, isolated outputs)	DIFF with bias resistors RSE

Differential Connection Considerations (DIFF Configuration)

Differential connections are those in which each DAQCard-1200 analog input signal has its own reference signal or signal return path. These connections are available when you configure the DAQCard-1200 in the DIFF mode. Each input signal is tied to the positive input of the instrumentation amplifier, and its reference signal, or return, is tied to the negative input of the instrumentation amplifier.

When you configure the DAQCard-1200 for DIFF input, each signal uses two of the multiplexer inputs—one for the signal and one for its reference signal. Therefore, only four analog input channels are available when using the DIFF configuration. You should use the DIFF input configuration when any of the following conditions is present:

- Input signals are low level (less than 1 V).
- Leads connecting the signals to the DAQCard-1200 are greater than 15 ft.
- Any of the input signals requires a separate ground-reference point or return signal.
- The signal leads travel through noisy environments.

Differential signal connections reduce picked-up noise and increase common-mode signal and noise rejection. With these connections, input signals can float within the common-mode limits of the input instrumentation amplifier.

Differential Connections for Grounded Signal Sources

Figure 3-3 shows how to connect a ground-referenced signal source to a DAQCard-1200 configured for DIFF input. Refer to the [Analog Input Configuration](#) section in Chapter 2, [Installation and Configuration](#), for configuration instructions.

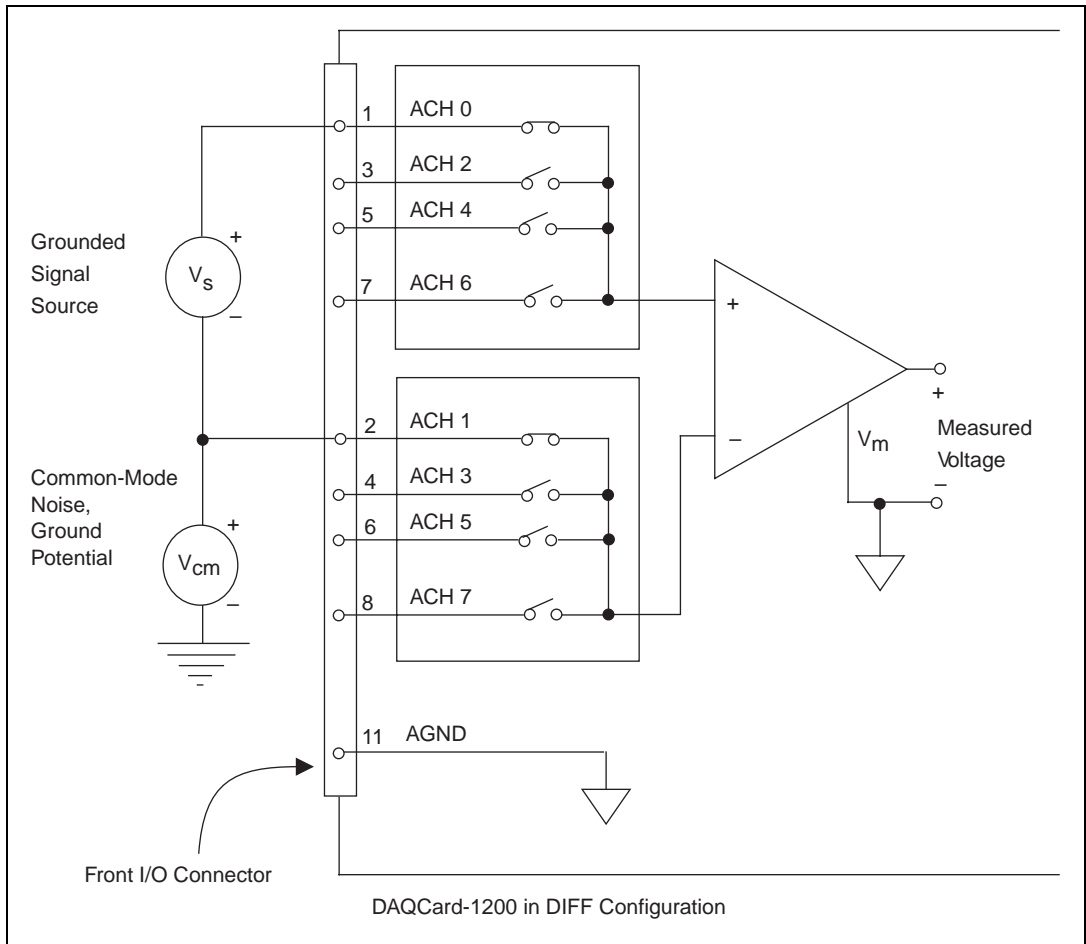

Figure 3-3. Differential Input Connections for Grounded Signal Sources

With this type of connection, the instrumentation amplifier rejects both the common-mode noise in the signal and the ground-potential difference between the signal source and the DAQCard-1200 ground, which is shown as V_{cm} in Figure 3-3.

Differential Connections for Floating Signal Sources

Figure 3-4 shows how to connect a floating signal source to a DAQCard-1200 that is configured for DIFF input. Configuration instructions are included in the [Analog Input Configuration](#) section of Chapter 2, [Installation and Configuration](#).

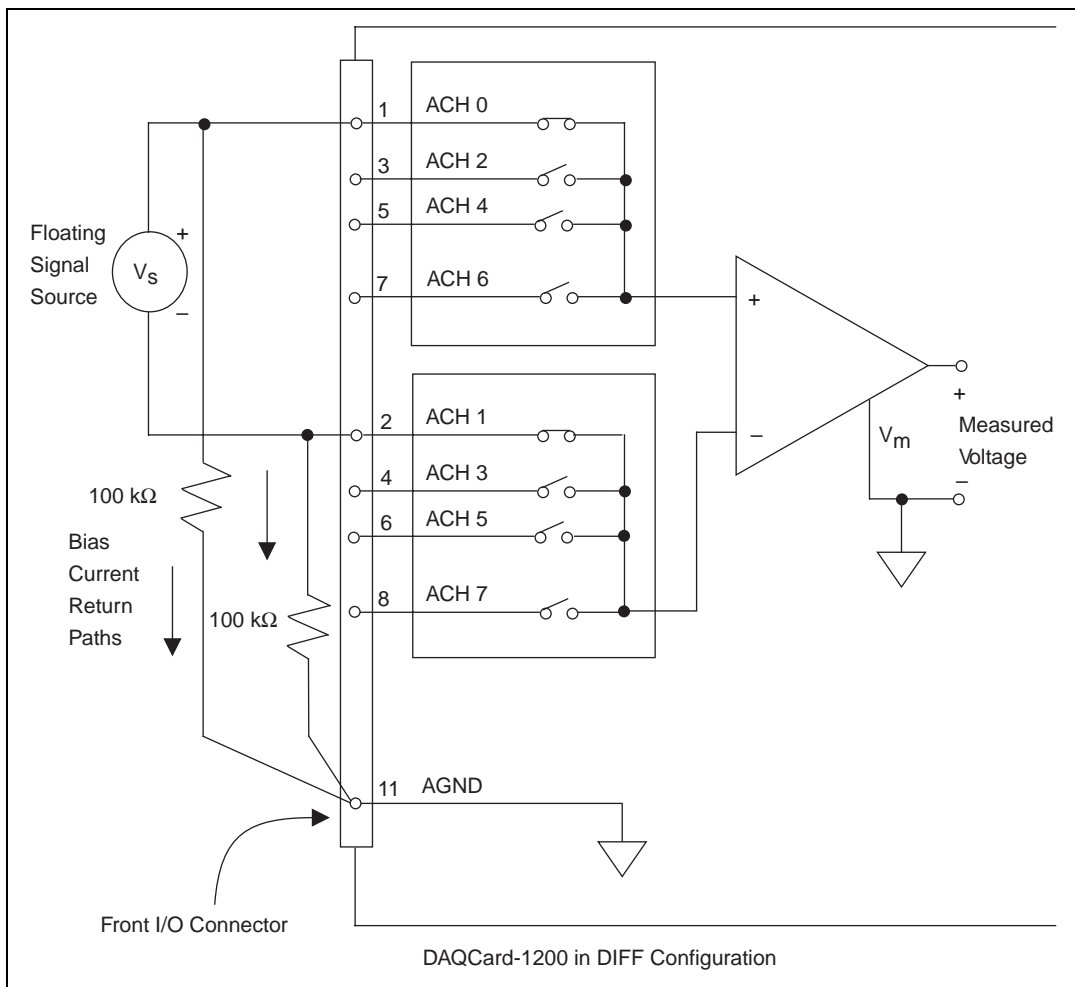

Figure 3-4. Differential Input Connections for Floating Sources

The $100\text{ k}\Omega$ resistors shown in Figure 3-4 create a return path to ground for the bias currents of the instrumentation amplifier. If there is no return path, the instrumentation amplifier bias currents charge stray capacitances, resulting in uncontrollable drift and possible saturation in the amplifier.

A resistor from each input to ground, as shown in Figure 3-4, provides bias current return paths for an AC-coupled input signal.

If the input signal is DC-coupled, you need only the resistor that connects the negative signal input to ground. This connection does not lower the input impedance of the analog input channel.

Single-Ended Connection Considerations

Single-ended connections are those in which all DAQCard-1200 analog input signals are referenced to one common ground. The input signals are tied to the positive input of the instrumentation amplifier, and their common ground point is tied to the negative input of the instrumentation amplifier.

When the DAQCard-1200 is configured for single-ended input (NRSE or RSE), eight analog input channels are available. You can use single-ended input connections when the following criteria are met by all input signals:

- Input signals are high level (greater than 1 V).
- Leads connecting the signals to the DAQCard-1200 are less than 15 ft.
- All input signals share a common reference signal (at the source).

If any of the preceding criteria is not met, you should use DIFF input configuration.

You can software configure the DAQCard-1200 for two different types of single-ended connections, RSE configuration and NRSE configuration. Use the RSE configuration for floating signal sources; in this case, the DAQCard-1200 provides the reference ground point for the external signal. Use the NRSE configuration for ground-referenced signal sources; in this case, the external signal supplies its own reference ground point and the DAQCard-1200 should not supply one.

Single-Ended Connections for Floating Signal Sources (RSE Configuration)

Figure 3-5 shows how to connect a floating signal source to a DAQCard-1200 configured for single-ended input. You must configure the DAQCard-1200 analog input circuitry for RSE input to make these types of connections. For configuration instructions, refer to the [Analog Input Configuration](#) section of Chapter 2, *Installation and Configuration*.

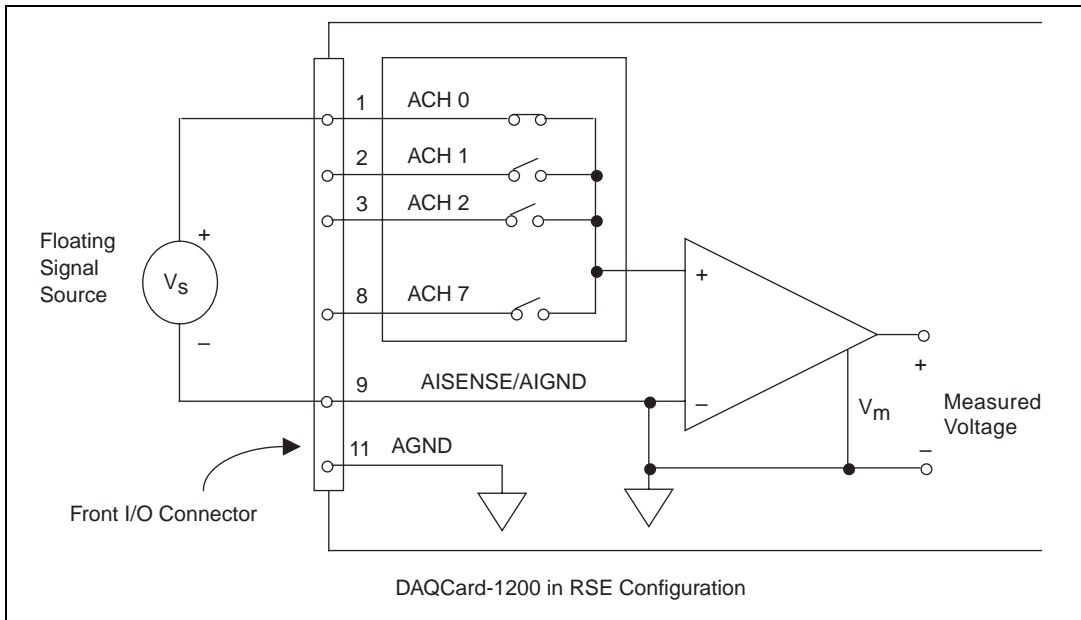

Figure 3-5. Single-Ended Input Connections for Floating Signal Sources

Single-Ended Connections for Grounded Signal Sources (NRSE Configuration)

If you measure a grounded signal source with a single-ended configuration, you must configure the DAQCard-1200 in the NRSE input configuration. The signal is connected to the positive input of the DAQCard-1200 instrumentation amplifier and the signal local ground reference is connected to the negative input of the DAQCard-1200 instrumentation amplifier. Therefore, you must connect the ground point of the signal to the AISENSE pin. Any potential difference between the DAQCard-1200 ground and the signal ground appears as a common-mode signal at both the positive and negative inputs of the instrumentation amplifier and is therefore rejected by the amplifier. On the other hand, if the input circuitry of the DAQCard-1200 is referenced to ground, such as in the RSE configuration, this difference in ground potentials appears as an error in the measured voltage.

Figure 3-6 shows how to connect a grounded signal source to a DAQCard-1200 configured in the NRSE configuration. For configuration instructions, see the [Analog Input Configuration](#) section in Chapter 2, [Installation and Configuration](#).

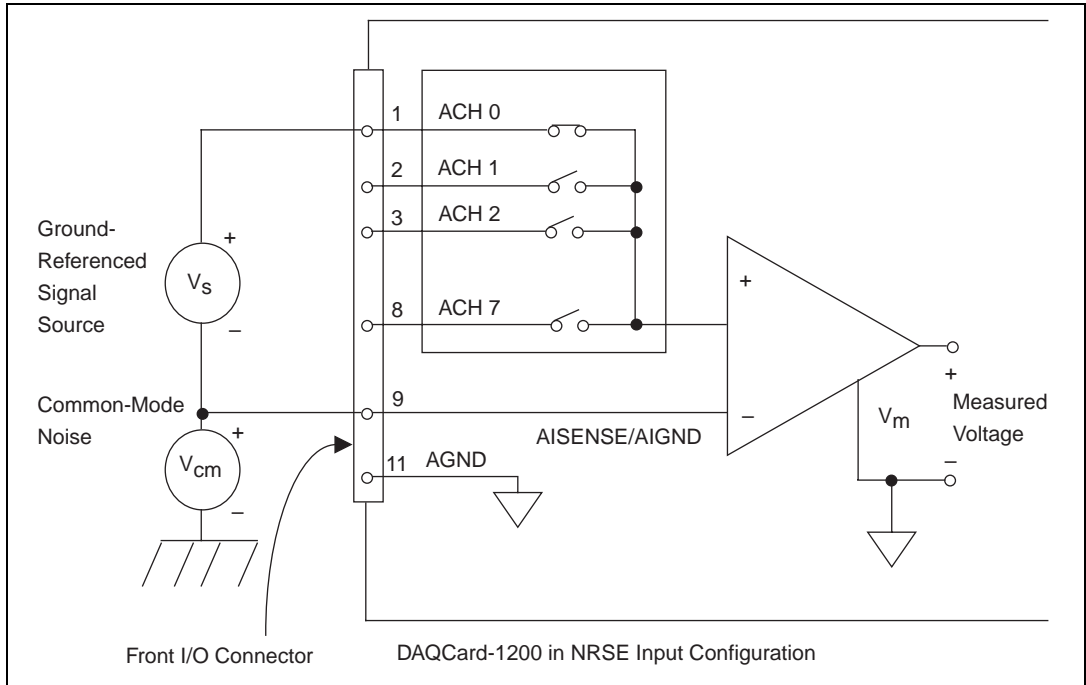

Figure 3-6. Single-Ended Input Connections for Grounded Signal Sources

Common-Mode Signal Rejection Considerations

Figures 3-3 and 3-6 show connections for signal sources that are already referenced to some ground point with respect to the DAQCard-1200. In these cases, the instrumentation amplifier can reject any voltage caused by ground-potential differences between the signal source and the DAQCard-1200. In addition, with differential input connections, the instrumentation amplifier can reject common-mode noise pickup in the leads connecting the signal sources to the DAQCard-1200.

The common-mode input range of the DAQCard-1200 instrumentation amplifier is the magnitude of the greatest common-mode signal that can be rejected.

The common-mode input range for the DAQCard-1200 depends on the size of the differential input signal ($V_{diff} = V_{in+} - V_{in-}$) and the gain setting of the instrumentation amplifier. In unipolar mode, the differential input range is 0 to 10 V. In bipolar mode, the differential input range is -5 to +5 V.

V_{in-} should remain within a range of -6 to 6 V in bipolar mode and -6 to

2 V in unipolar mode. V_{in+} should remain within a range of -6 to $+11$ V in either mode.

Analog Output Signal Connections

Pins 10 through 12 of the front connector are the analog output signals DAC0OUT, AGND, and DAC1OUT.

DAC0OUT is the voltage output signal for analog output channel 0.

DAC1OUT is the voltage output signal for analog output channel 1. AGND is the ground-reference point for both analog output channels and analog input.

The following output ranges are available:

- Output signal range
 - Bipolar output ± 5 V*
 - Unipolar output 0 to 10 V*

*Maximum load current ± 1 mA for 12-bit linearity (per DAC)

Figure 3-7 shows how to make analog output signal connections.

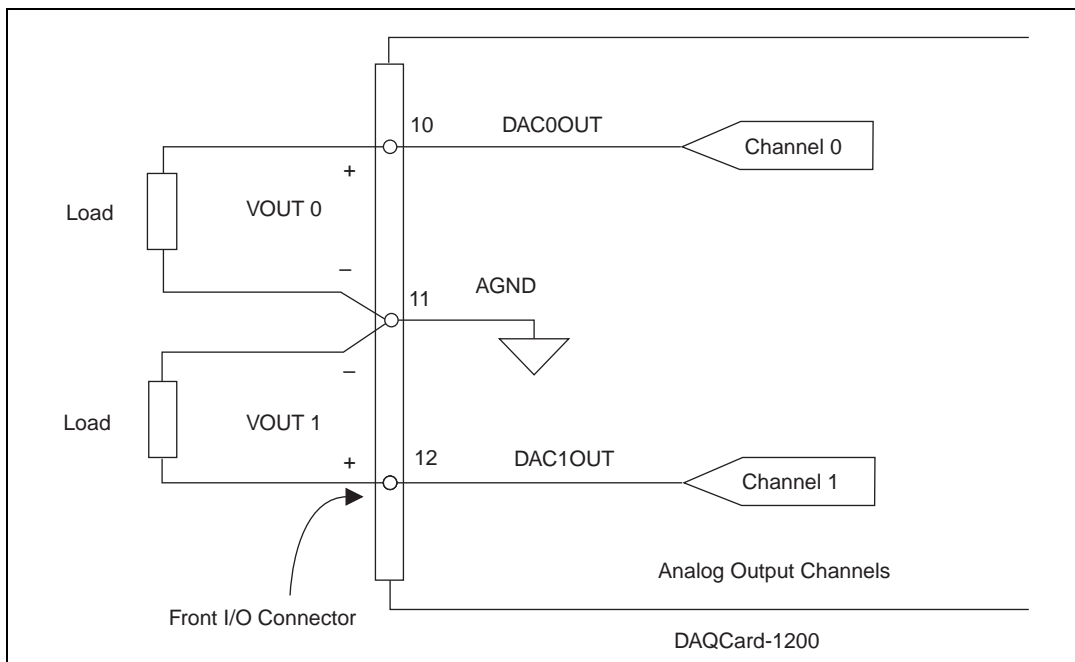

Figure 3-7. Analog Output Signal Connections

Digital I/O Signal Connections

**Caution**

The DAQCard-1200 DIO lines are not pulled up or pulled down. If you are using these lines as digital outputs, add 10 k Ω resistors to +5 V or DGND (depending on your application) to the DIO line(s) you are using.

Pins 13 through 37 of the front connector are digital I/O signal pins. Digital I/O on the DAQCard-1200 uses the 82C55A integrated circuit. The 82C55A is a general-purpose peripheral interface containing 24 programmable I/O pins. These pins represent the three 8-bit ports (PA, PB, and PC) of the 82C55A.

Pins 14 through 21 are connected to the digital lines PA<0..7> for digital I/O port A. Pins 22 through 29 are connected to the digital lines PB<0..7> for digital I/O port B. Pins 30 through 37 are connected to the digital lines PC<0..7> for digital I/O port C. Pin 13, DGND, is the digital ground pin for all three digital I/O ports. Refer to Appendix A, [Specifications](#), for signal voltage and current specifications.

Figure 3-8 illustrates signal connections for three typical digital I/O applications.

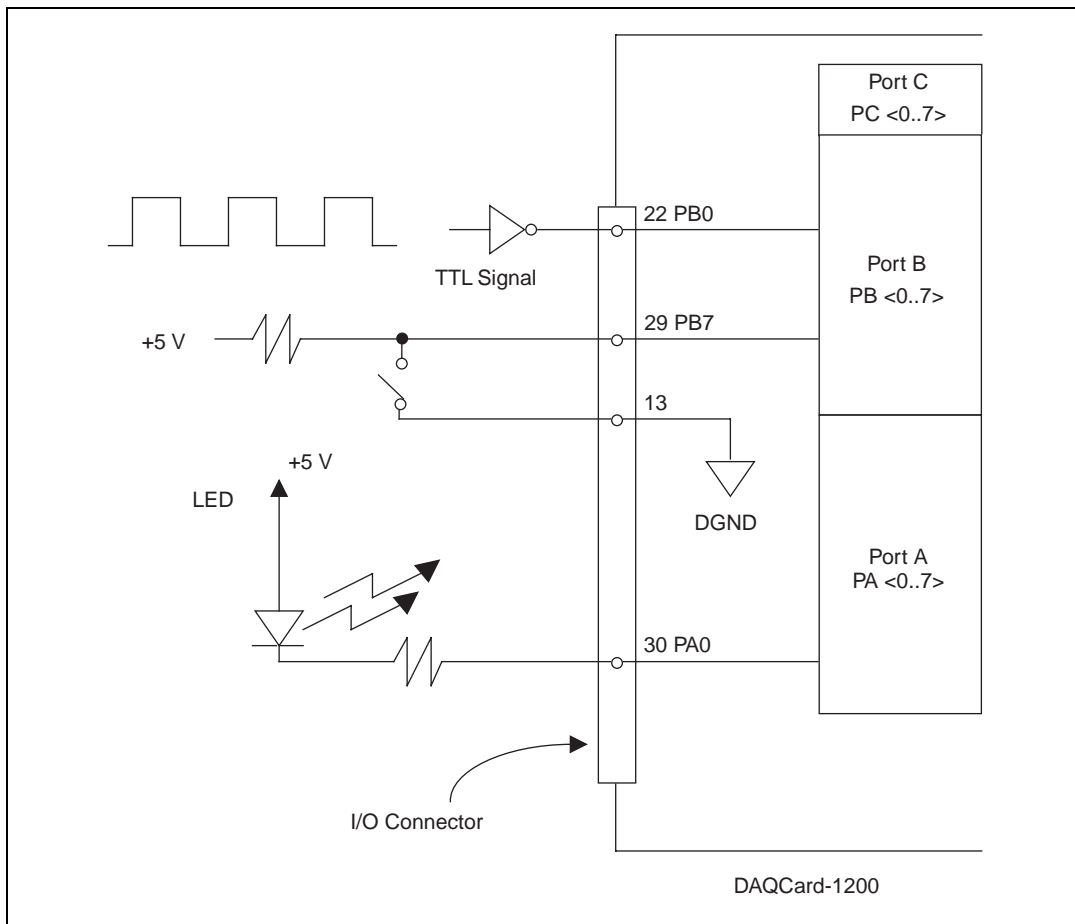

Figure 3-8. Digital I/O Connections

In Figure 3-8, port A is configured for digital output, and ports B and C are configured for digital input. Digital input applications include receiving TTL signals and sensing external device states such as the switch in Figure 3-8. Digital output applications include sending TTL signals and driving external devices such as the LED shown in Figure 3-8.

Port C Pin Connections

The signals assigned to port C depend on how the 82C55A is configured. In mode 0 or no handshaking configuration, port C is configured as two 4-bit I/O ports. In modes 1 and 2, or handshaking configuration, port C is used for status and handshaking signals with zero, two, or three lines available for general-purpose I/O. Table 3-3 summarizes the port C signal assignments for each configuration.



Note

Table 3-3 shows both the port C signal assignments and the terminology correlation between different documentation sources. The 82C55A terminology refers to the different 82C55A configurations as modes, whereas NI-DAQ and LabVIEW documentation refers to them as handshaking and no handshaking. These signal assignments are the same for all four 82C55A PPIs.

Table 3-3. Port C Signal Assignments

Configuration Terminology		Signal Assignments							
82C55A/ DAQCard-1200 User Manual	NI-DAQ/ LabVIEW	PC7	PC6	PC5	PC4	PC3	PC2	PC1	PC0
Mode 0 (Basic I/O)	No Handshaking	I/O	I/O	I/O	I/O	I/O	I/O	I/O	I/O
Mode 1 (Strobed Input)	Handshaking	I/O	I/O	IBF _A	STB _A *	INTR _A	STB _B *	IBFB _B	INTR _B
Mode 1 (Strobed Output)	Handshaking	OBF _A *	ACK _A *	I/O	I/O	INTR _A	ACK _B *	OBF _B *	INTR _B
Mode 2 (Bidirectional Bus)	Handshaking	OBF _A *	ACK _A *	IBF _A	STB _A *	INTR _A	I/O	I/O	I/O
*Indicates that the signal is active low. Subscripts A and B denote port A or port B handshaking signals.									

Timing Specifications

Use the handshaking lines STB* and IBF to synchronize input transfers. Use the handshaking lines OBF* and ACK* to synchronize output transfers.

The following signals are used in the timing diagrams shown later in this chapter:

Name	Type	Description
STB*	Input	Strobe Input—A low signal on this handshaking line loads data into the input latch.
IBF	Output	Input Buffer Full—A high signal on this handshaking line indicates that data has been loaded into the input latch. This is primarily an input acknowledge signal.
ACK*	Input	Acknowledge Input—A low signal on this handshaking line indicates that the data written from the specified port has been accepted. This signal is primarily a response from the external device that it has received the data from the DAQCard-1200.
OBF*	Output	Output Buffer Full—A low signal on this handshaking line indicates that data has been written from the specified port.
INTR	Output	Interrupt Request—This signal becomes high when the 82C55A requests service during a data transfer. Set the appropriate interrupt enable signals to generate this signal.
RD*	Internal	Read—This signal is the read signal generated from the parallel port interface circuitry.
WRT*	Internal	Write—This signal is the write signal generated from the parallel port interface circuitry.
DATA	Bidirectional	Data Lines at the Specified Port—This signal indicates when the data on the data lines at a specified port is or should be available.

Mode 1 Input Timing

Figure 3-9 shows the timing specifications for an input transfer in mode 1.

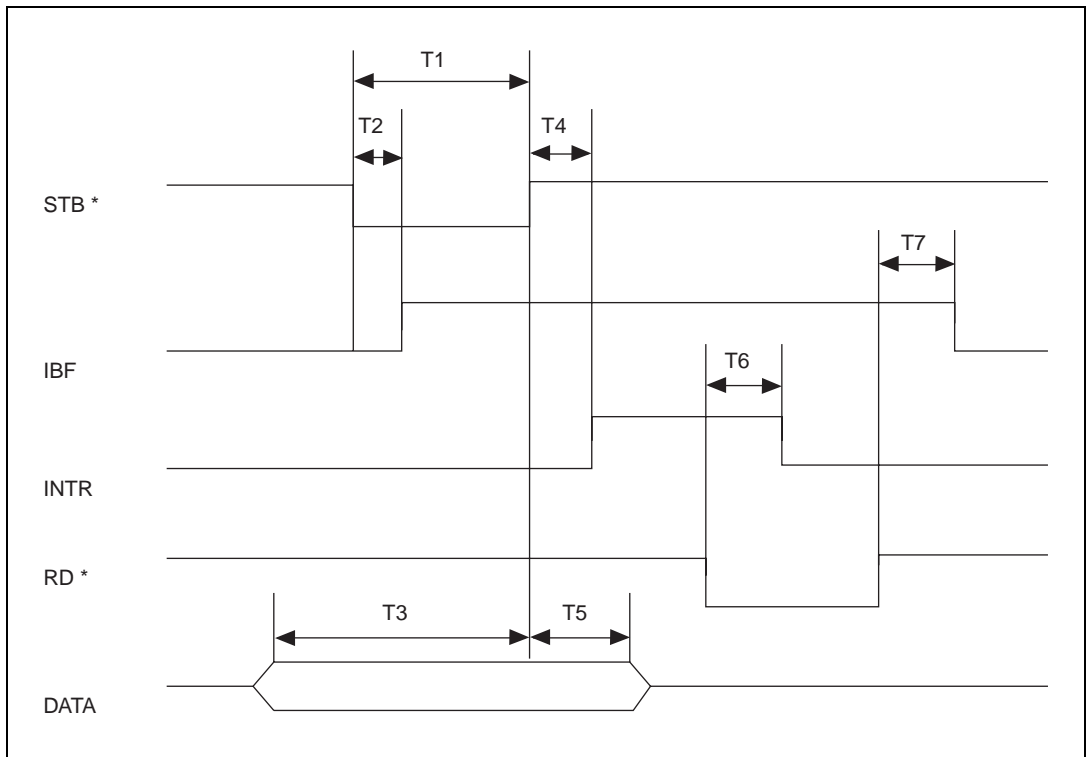

Name	Description	Minimum	Maximum
T1	STB* pulse width	100	—
T2	STB* = 0 to IBF = 1	—	150
T3	Data before STB* = 1	20	—
T4	STB* = 1 to INTR = 1	—	150
T5	Data after STB* = 1	50	—
T6	RD* = 0 to INTR = 0	—	200
T7	RD* = 1 to IBF = 0	—	150

All timing values are in nanoseconds.

Figure 3-9. Mode 1 Timing Specifications for Input Transfers

Mode 1 Output Timing

Figure 3-10 shows the timing specifications for an output transfer in mode 1.

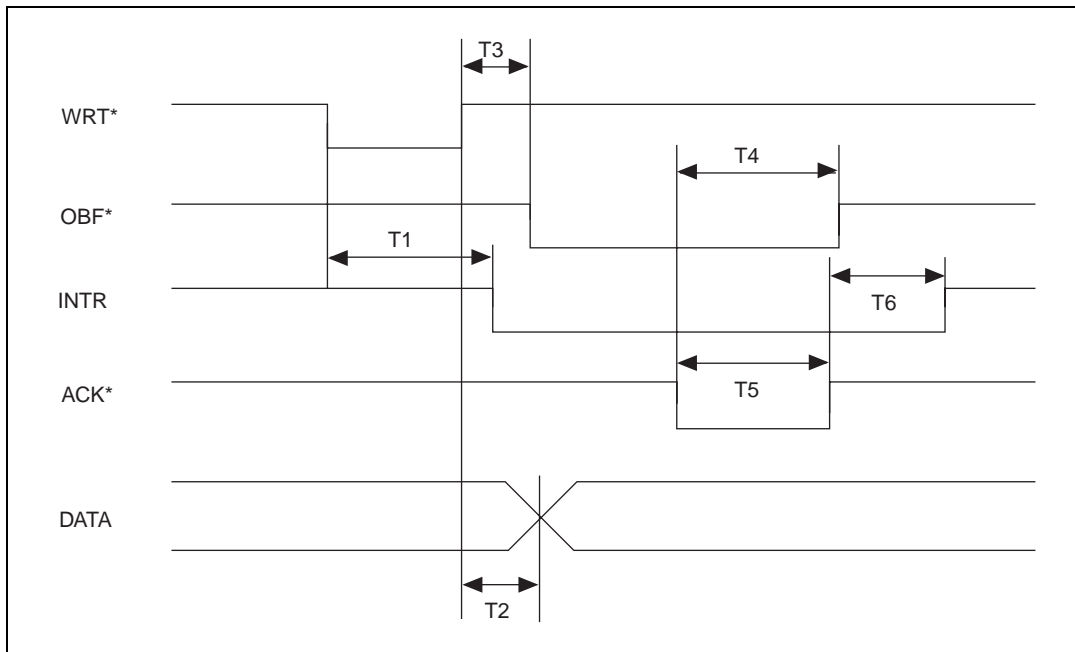

Name	Description	Minimum	Maximum
T1	WRT* = 0 to INTR = 0	—	250
T2	WRT* = 1 to output	—	200
T3	WRT* = 1 to OBF* = 0	—	150
T4	ACK* = 0 to OBF* = 1	—	150
T5	ACK* pulse width	100	—
T6	ACK* = 1 to INTR = 1	—	150

All timing values are in nanoseconds.

Figure 3-10. Mode 1 Timing Specifications for Output Transfers

Mode 2 Bidirectional Timing

Figure 3-11 shows the timing specifications for bidirectional transfers in mode 2.

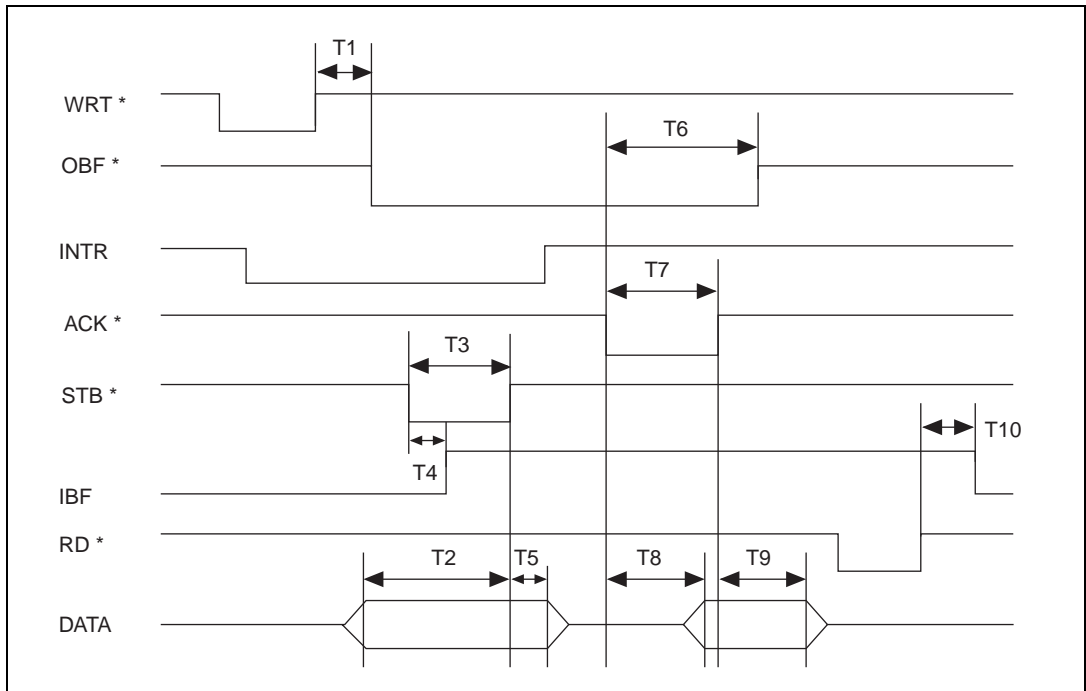

Name	Description	Minimum	Maximum
T1	WRT* = 1 to OBF* = 0	—	150
T2	Data before STB* = 1	20	—
T3	STB* pulse width	100	—
T4	STB* = 0 to IBF = 1	—	150
T5	Data after STB* = 1	50	—
T6	ACK* = 0 to OBF = 1	—	150
T7	ACK* pulse width	100	—
T8	ACK* = 0 to output	—	150
T9	ACK* = 1 to output float	20	250
T10	RD* = 1 to IBF = 0	—	150

All timing values are in nanoseconds.

Figure 3-11. Mode 2 Timing Specifications for Bidirectional Transfers

DAQ and General-Purpose Timing Signal Connections

Pins 38 through 48 of the front connector are connections for timing I/O signals. The DAQCard-1200 timing I/O uses two 82C53 counter/timer integrated circuits. One circuit, designated 82C53(A), is used exclusively for DAQ timing, and the other, 82C53(B), is available for general use. You can use pins 38 through 40 and pin 43 to carry external signals for DAQ timing in place of the dedicated 82C53(A). These signals are explained in the next section, *DAQ Timing Connections*. Pins 41 through 48 carry general-purpose timing signals from 82C53(B). These signals are explained in the *General-Purpose Timing Signal Connections* section later in this chapter.

DAQ Timing Connections

Each 82C53 counter/timer circuit contains three counters. Counter 0 on the 82C53(A) counter/timer, referred to as A0, is a sample-interval counter in timed A/D conversions. Counter 1 on the 82C53(A) counter/timer, referred to as A1, is a sample counter in controlled A/D conversions. Therefore, counter A1 stops data acquisition after a predefined number of samples. These counters are not available for general use.

Instead of counter A0, you can use EXTCONV* to externally time conversions. Figure 3-12 shows the timing requirements for the EXTCONV* input. A falling edge on the EXTCONV* initiates an A/D conversion.

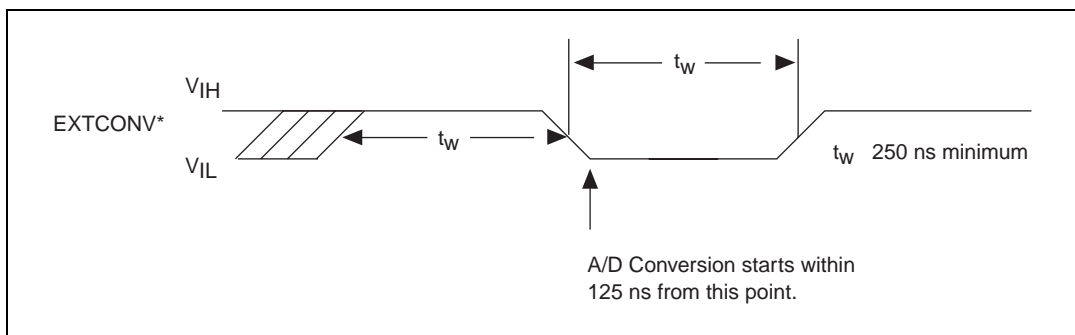

Figure 3-12. EXTCONV* Signal Timing

The external control signal EXTTRIG can either start a data acquisition sequence or terminate an ongoing data acquisition sequence depending on the mode—posttrigger or pretrigger. These modes are software selectable.

In the posttrigger mode, EXTTRIG serves as an external trigger that initiates a data acquisition sequence. When you use counter A0 to time sample intervals, a rising edge on EXTTRIG starts counter A0 and the data acquisition sequence. When you use EXTCONV* to time sample intervals, data acquisition is enabled on a rising edge of EXTTRIG followed by a rising edge on EXTCONV*. The first conversion occurs on the next falling edge of EXTCONV*. Further transitions on the EXTTRIG line have no effect until a new data acquisition sequence is established.

Figure 3-13 shows a possible controlled data acquisition sequence using EXTCONV* and EXTTRIG. The rising edge of EXTCONV* that enables external conversions must occur a minimum of 50 ns after the rising edge of EXTTRIG. The first conversion occurs on the next falling edge of EXTCONV*.

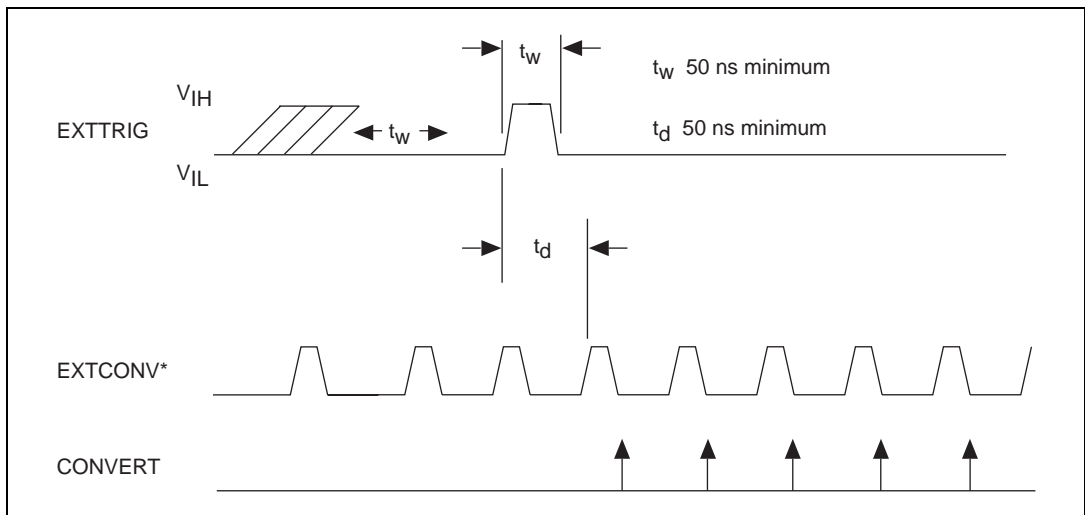

Figure 3-13. Posttrigger DAQ Timing

In the pretrigger mode, EXTTRIG serves as a stop-trigger signal. Data is acquired both before and after the stop trigger occurs. A/D conversions are software enabled, which initiates the data acquisition operation. However, the sample counter is not started until a rising edge is sensed on the EXTTRIG input. Conversions remain enabled until the sample counter counts to zero. The maximum number of samples acquired after the stop trigger is limited to 65,535. The number of samples acquired before the trigger is limited only by the size of the memory buffer available for data acquisition.

Figure 3-14 shows a pretrigger data acquisition timing sequence using EXTTRIG and EXTCONV*. The data acquisition operation has been initiated through software. Notice that the sample counter has been programmed to allow five conversions after the rising edge on the EXTTRIG signal. Additional transitions on the EXTTRIG line have no effect until you initiate a new data acquisition sequence.

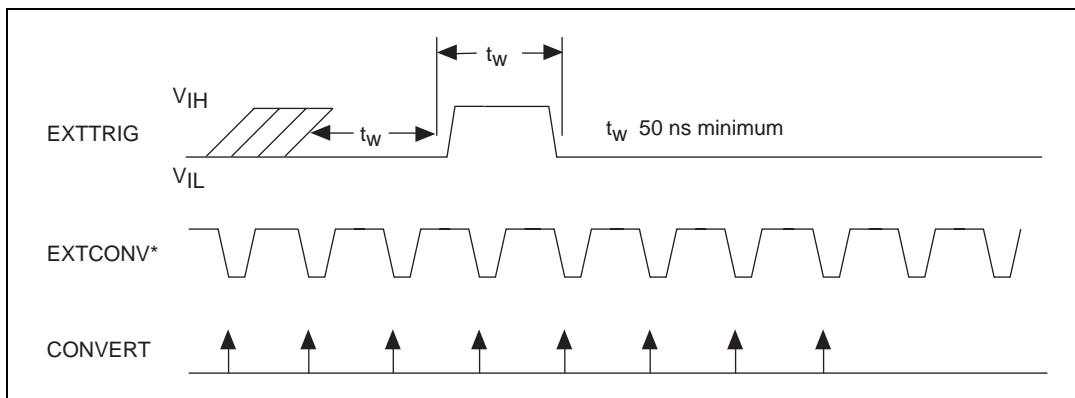

Figure 3-14. Pretrigger DAQ Timing

Because both pretrigger and posttrigger modes use EXTTRIG input, you can only use one mode at a time.

For interval scanning data acquisition, counter B1 determines the scan interval. Instead of using counter B1, you can externally time the scan interval through OUTB1. If you externally time the sample interval, you should also externally time the scan interval.

Figure 3-15 shows an example of a multiple-channel interval-scanning data acquisition operation. The scan interval and the sample interval are being timed externally through OUTB1 and EXTCONV*. Channels 1 and 0 of the input multiplexers are being scanned once during each scan interval. The first rising edge of EXTCONV* must occur a minimum of 50 ns after the rising edge on OUTB1. The first rising edge of EXTCONV* after the rising edge of OUTB1 enables an internal GATE signal that allows conversions to occur. The first conversion then occurs on the following falling edge of EXTCONV*.

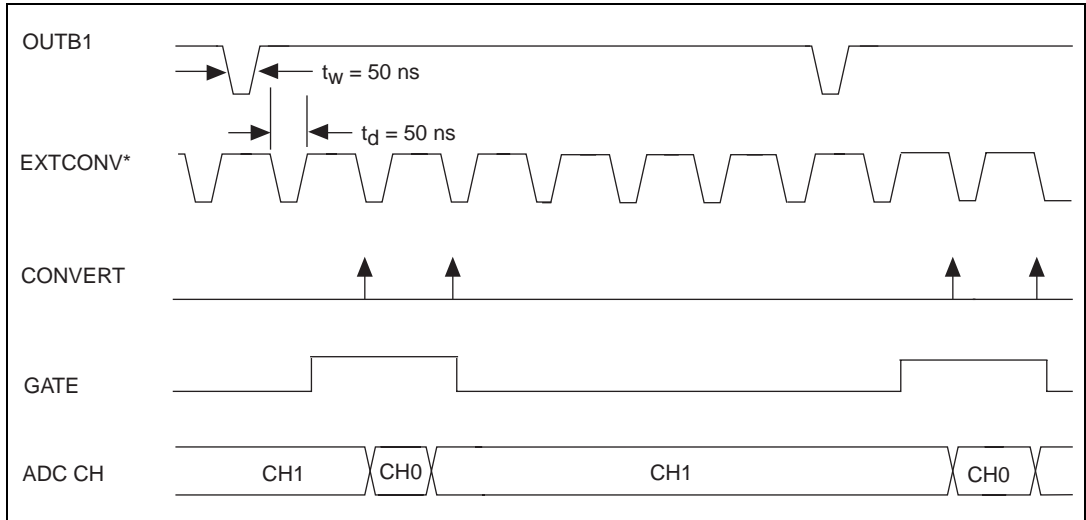

Figure 3-15. Interval-Scanning Signal Timing

Use the final external control signal, EXTUPDATE*, to externally control updating the output voltage of the 12-bit DACs and/or to generate an externally timed interrupt. There are two update modes—immediate update and delayed update. In immediate update mode the analog output is updated as soon as a value is written to the DAC. If you select the delayed update mode, a value is written to the DAC; however, the corresponding DAC voltage is not updated until a low level on the EXTUPDATE* signal is sensed. Furthermore, an interrupt is generated whenever a rising edge is detected on the EXTUPDATE* bit. The interrupt service routine can write the next value to the DAC. When the EXTUPDATE* signal goes low, the DAC will subsequently be updated. Therefore, you can perform externally timed interrupt-driven waveform generation on the DAQCard-1200.

Notice that the EXTUPDATE* signal is level sensitive; that is, if you perform writes to the DAC when EXTUPDATE* is low, the DAC is updated immediately. Also notice that when EXTUPDATE* is low, the signal is susceptible to noise caused by switching of other lines. Because the signal is TTL-compatible, the lower noise margin for logical 0 can result in transitions to a logical 1 due to noise and thereby generate false interrupts. Therefore, the width of EXTUPDATE* pulse should be as short as possible and greater than 50 ns.

Figure 3-16 illustrates a waveform generation timing sequence using the EXTUPDATE* signal and the delayed update mode. The DACs are updated by a high level on the DAC OUTPUT UPDATE signal, which in

this case is triggered by a low level on the EXTUPDATE* line. The counter-interrupt signal interrupts the PC. This interrupt is generated on the rising edge of EXTUPDATE*. The DACWRT signal writes a new value to the DAC.

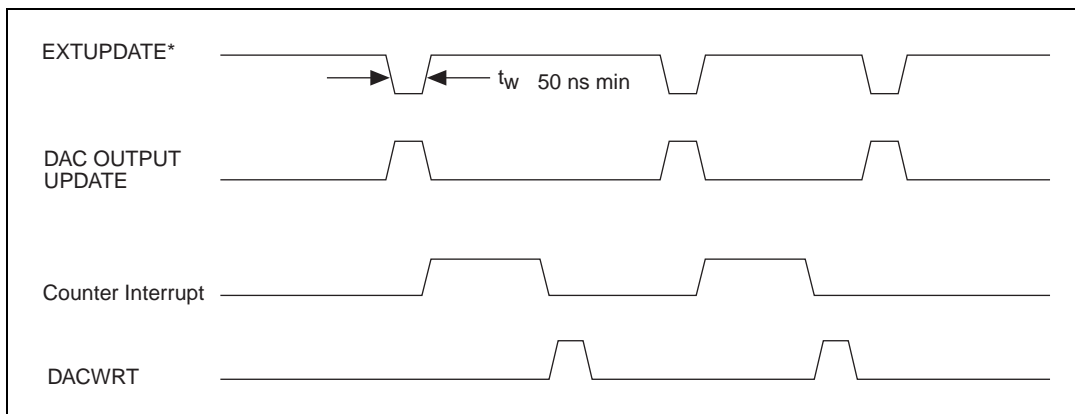



Figure 3-16. EXTUPDATE* Signal Timing for Updating DAC Output

The following rating applies to the EXTCONV*, EXTTRIG, OUTB1, and EXTUPDATE* signals.

- Absolute maximum voltage input rating –0.5 to 5.5 V with respect to DGND

For more information concerning the various modes of data acquisition and analog output, refer to your NI-DAQ manual or to Chapter 4, *Theory of Operation*.

 **Note**

*You should configure both DACs in either immediate update mode or in later update mode, but not in a combination of the two modes. Although you can configure the DACs in a combination of modes, doing so can result in glitches on the immediate update DAC if the update rate on the waveform DAC is high. Please refer to the Analog Output section in Chapter 4, *Theory of Operation*, for details on this behavior.*

General-Purpose Timing Signal Connections

General-purpose timing signals include the GATE, CLK, and OUT signals for the three 82C53(B) counters. The 82C53 counter/timers can be used for general-purpose applications such as pulse and square wave generation; event counting; and pulsewidth, time-lapse, and frequency measurement. For these applications, the CLK and GATE signals at the front I/O connector control the counters. The single exception is counter B0,

which has an internal 2 MHz clock. Refer to the *DAQCard-1200 Register-Level Programmer Manual* for programming information.

The GATE, CLK, and OUT signals for counters B1 and B2 are available at the I/O front connector. The GATE and CLK pins are internally pulled up to +5 V through a 100 k Ω resistor. Refer to Appendix A, *Specifications*, for signal voltage and current specifications.

You perform pulse and square wave generation by programming a counter to generate a timing signal at its OUT output pin. Perform event counting by programming a counter to count rising or falling edges applied to any of the 82C53 CLK inputs. You can then read the counter value to determine the number of edges that have occurred. You can gate counter operations on and off during event counting. Figure 3-17 shows connections for a typical event-counting operation in which a switch is used to gate the counter on and off.

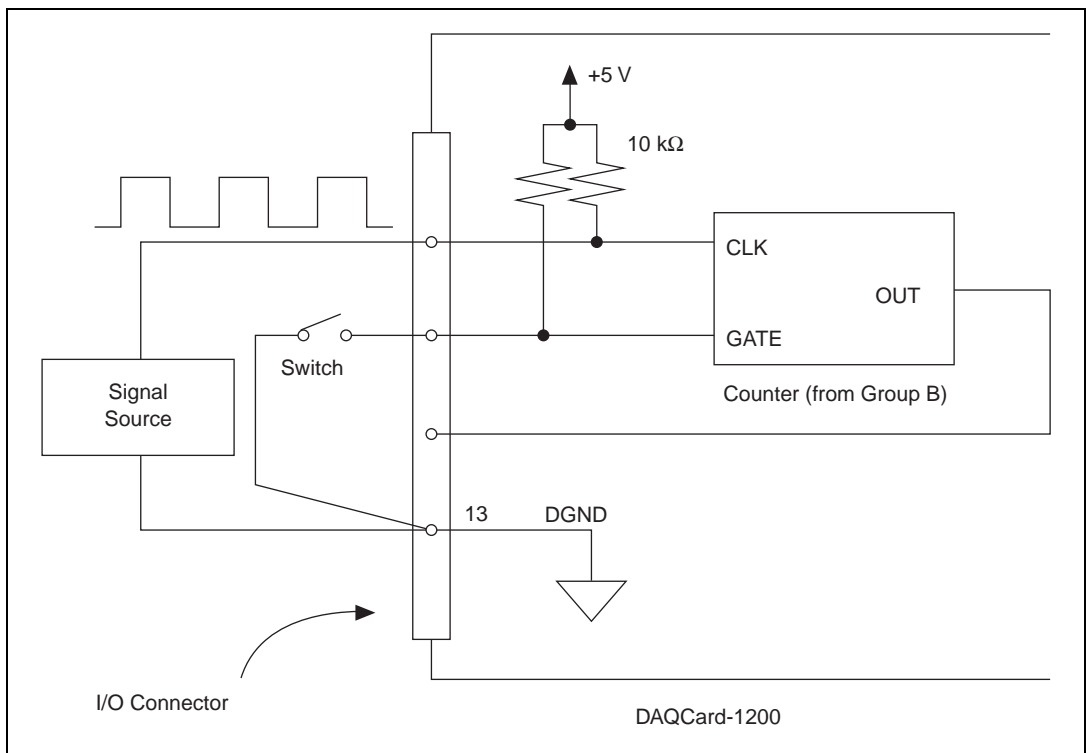

Figure 3-17. Event-Counting Application with External Switch Gating

Pulsewidth measurement is performed by level gating. The pulse you want to measure is applied to the counter GATE input. The counter is loaded with the known count and is programmed to count down while the signal at the GATE input is high. The pulse width equals the counter difference (loaded value minus read value) multiplied by the CLK period.

Perform time-lapse measurement by programming a counter to be edge gated. An edge is applied to the counter GATE input to start the counter. You can program the counter to start counting after receiving a low-to-high edge. The time lapse since receiving the edge equals the counter value difference (loaded value minus read value) multiplied by the CLK period.

To perform frequency measurement, program a counter to be level gated and count the number of falling edges in a signal applied to a CLK input. The gate signal applied to the counter GATE input is of known duration. In this case, you program the counter to count falling edges at the CLK input while the gate is applied. The frequency of the input signal then equals the count value divided by the gate period. Figure 3-18 shows the connections for a frequency measurement application. You can also use a second counter to generate the gate signal in this application. In this case, program the second counter for a one-slot mode. This configuration requires an external inverter to make the output pulse of the second counter active high.

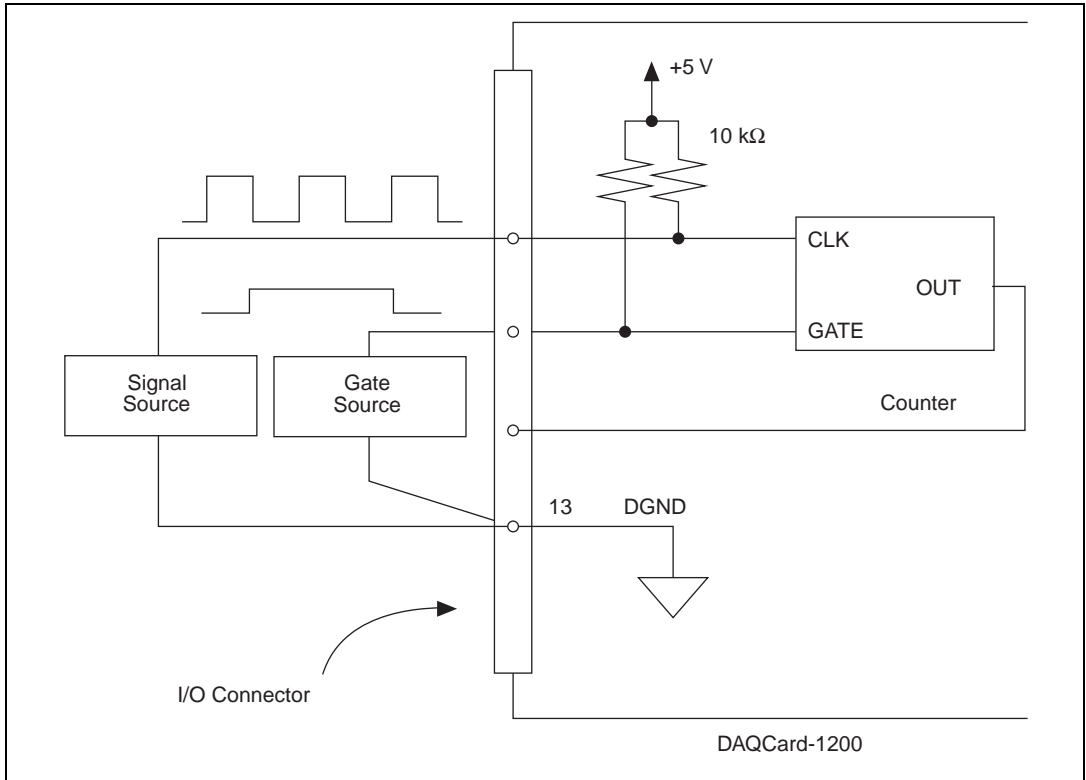

Figure 3-18. Frequency Measurement Application

Figure 3-19 shows the timing requirements for the GATE and CLK input signals and the timing specifications for the OUT output signals of the 82C53.

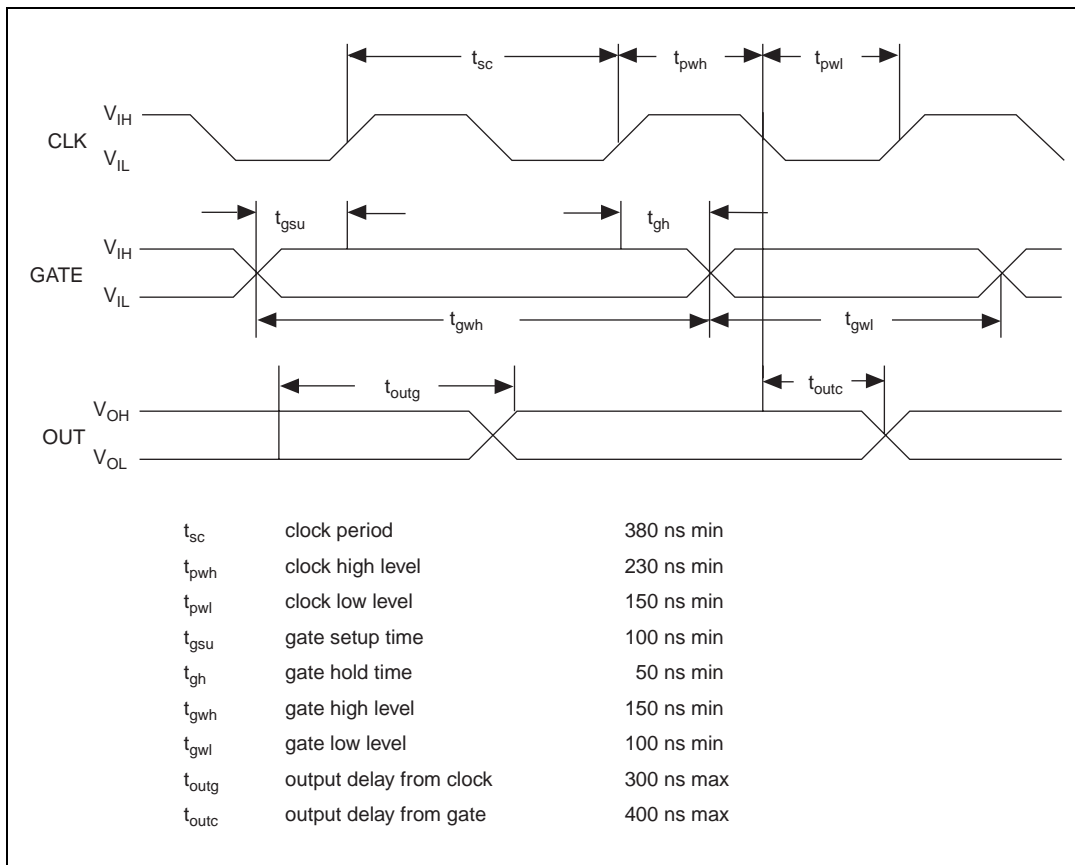

Figure 3-19. General-Purpose Timing Signals

The GATE and OUT signals in Figure 3-19 are referenced to the rising edge of the CLK signal.

Power Connections

Pin 49 of the I/O connector supplies +5 V from the DAQCard-1200 power supply. This pin is referenced to DGND. You can use the +5 V to power external digital circuitry.

- Power rating 250 mA at +5 V maximum, fused to 1 A



Warning *Do not directly connect this +5 V power pin to analog or digital ground or to any other voltage source on the DAQCard-1200 or any other device. Doing so can damage the DAQCard-1200 or your PC. National Instruments is NOT liable for any damage due to incorrect power connections.*

Pin 49 is fused for up to 1 A, but should be limited to 250 mA. The fuse is a thermally resettable fuse which has an internal thermostat. This thermostat opens when the current exceeds 1 A and the temperature rises. After some time, the thermostat cools down, the switch closes, and the +5 V is available once more. Opening this fuse does not necessarily damage the DAQCard-1200. If you do not receive +5 V, check for any shorts between the +5 V power pin and ground.

Theory of Operation

This chapter explains the operation of each functional unit of the DAQCard-1200.

Functional Overview

The block diagram in Figure 4-1 shows a functional overview of the DAQCard-1200.

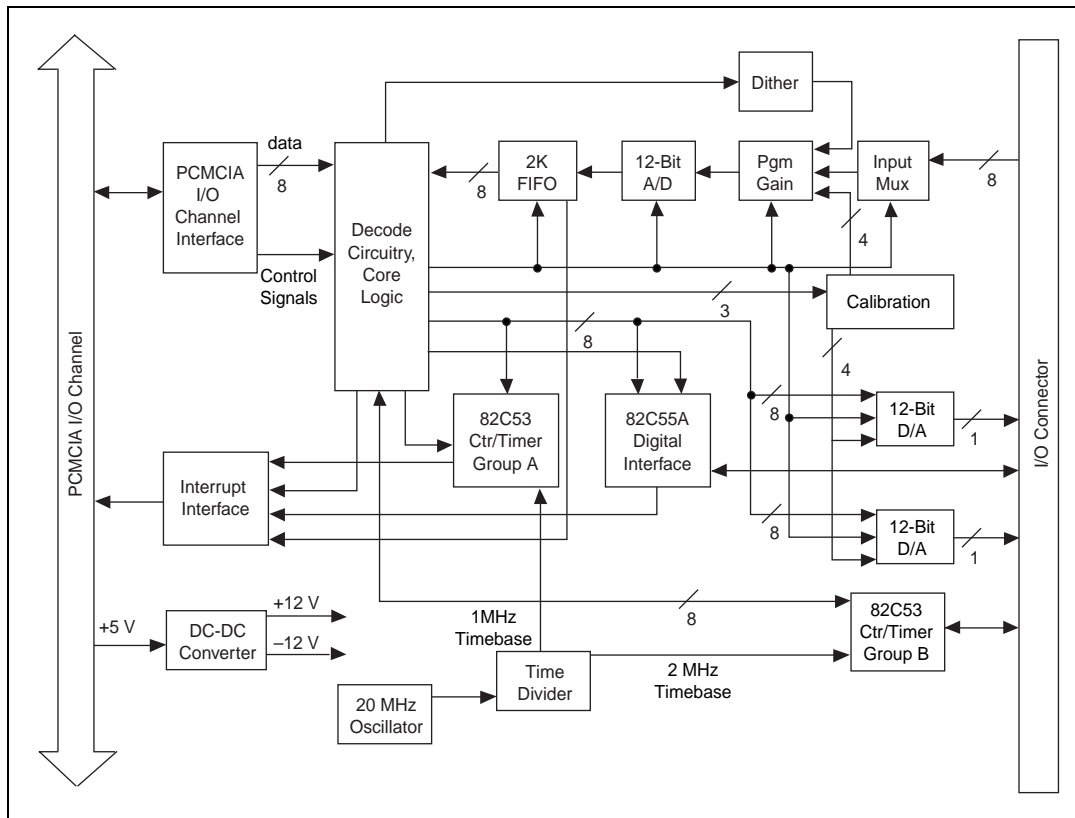

Figure 4-1. DAQCard-1200 Block Diagram

The major components of the DAQCard-1200 are as follows:

- PC Card I/O channel interface circuitry
- Analog input circuitry
- Analog output circuitry
- Digital I/O circuitry
- Timing circuitry
- Calibration circuitry

The internal data and control buses interconnect the components. The rest of the chapter explains the theory of operation of each of the DAQCard-1200 components.

PC Card I/O Channel Interface Circuitry

The PC Card I/O channel interface circuitry consists of an address bus, a data bus, interrupt lines, and several control and support signals. Figure 4-2 shows the components making up the DAQCard-1200 PC Card I/O channel interface circuitry.

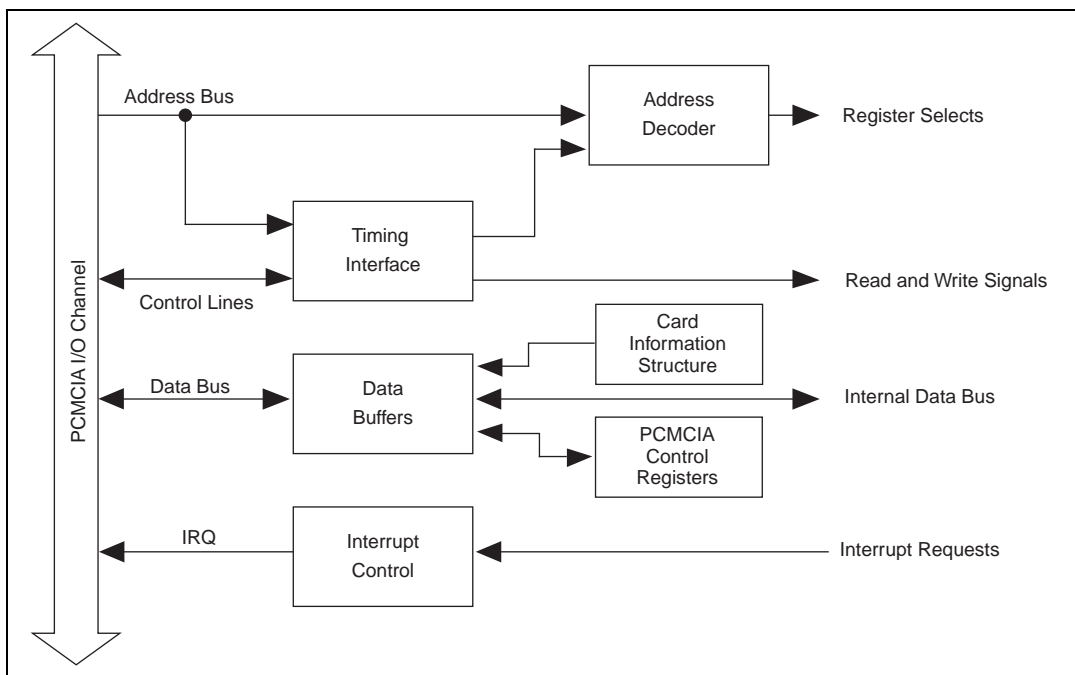

Figure 4-2. PC Card I/O Interface Circuitry Block Diagram

When you first insert the card into your computer, the system examines information stored in the DAQCard-1200 Card Information Structure (CIS). This data is used to configure the card appropriately for the system in which it is used. When the system has assigned the card to a section of memory, it updates the PC Card control registers and initializes the card.

The rest of the circuitry consists of address decoders, data buffers, I/O channel interface timing control circuitry, and interrupt control circuitry.

Timing

The DAQCard-1200 uses two 82C53 counter/timer integrated circuits for internal data acquisition and DAC timing and for general-purpose I/O timing functions. Figure 4-3 shows a block diagram of both groups of timing circuitry (counter groups A and B).

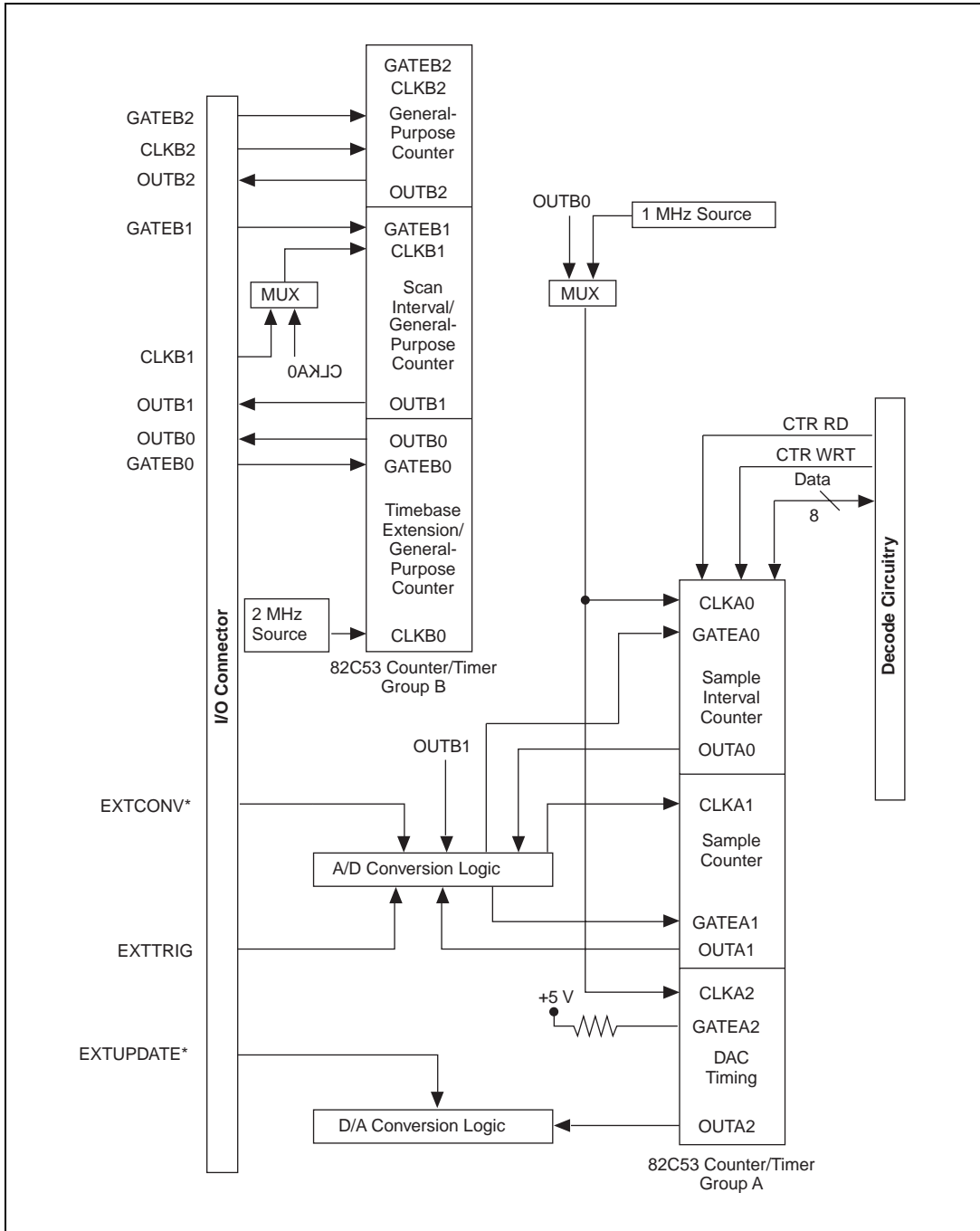

Figure 4-3. Timing Circuitry

Each 82C53 contains three independent 16-bit counter/timers and one 8-bit Mode Register. Each counter has a CLK input pin, a GATE input pin, and an OUT output pin. You can program all three counter/timers to operate in several useful timing modes.

The first group of counter/timers is called Group A and includes A0, A1, and A2. You can use these three counters for internal data acquisition and DAC timing, or you can instead use the three external timing signals, EXTCONV*, EXTTRIG and EXTUPDATE*, for data acquisition and DAC timing.

The second group of counter/timers is called Group B and includes B0, B1, and B2. You can use counters B0 and B1 for internal data acquisition and DAC timing, or you can use the external timing signal CLKB1 for analog input timing. If you are not using Counters B0 and B1 for internal timing, you can use these counters as general purpose counter/timers. Counter B2 is reserved for external use as a general purpose counter/timer.

For a more detailed description of Counter Group A and Counters B0 and B1, refer to the following *Analog Input* and *Analog Output* sections.

Analog Input

The DAQCard-1200 has eight channels of analog input with software-programmable gain and 12-bit A/D conversion. The DAQCard-1200 also contains data acquisition timing circuitry for automatic timing of multiple A/D conversions and includes advanced options such as external triggering, gating, and clocking. Figure 4-4 shows a block diagram of the analog input circuitry.

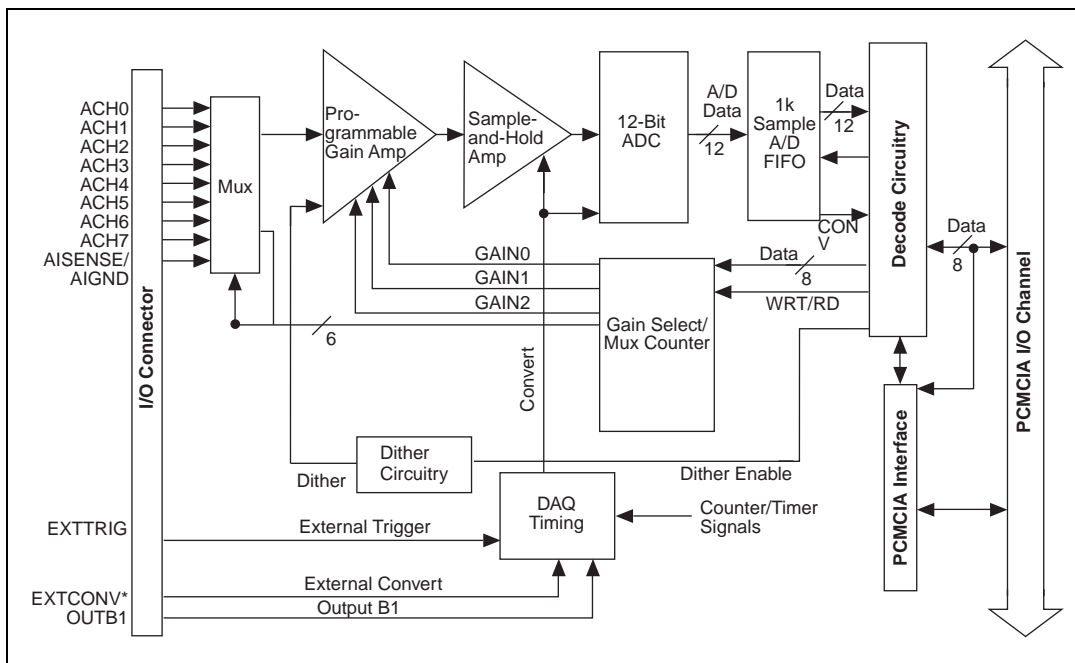

Figure 4-4. Analog Input Circuitry

Analog Input Circuitry

The analog input circuitry consists of two analog input multiplexers, mux counter/gain select circuitry, a software-programmable gain amplifier, a 12-bit ADC, and a 12-bit FIFO memory that is sign-extended to 16 bits.

The two input multiplexers route the input channels to the instrumentation amplifier in either RSE, NRSE, or DIFF mode. The input multiplexers provide input overvoltage protection of ± 35 V powered on and ± 25 V powered off.

The mux counters control the input multiplexers. The DAQCard-1200 can perform either single-channel data acquisition or multiple-channel (scanned) data acquisition. These two modes are software selectable. For single-channel data acquisition, you select the channel and gain before initiating data acquisition. These gain and multiplexer settings remain constant during the entire data acquisition process. For multiple-channel data acquisition, you select the highest numbered channel and gain before data acquisition is initiated. Then the mux counter decrements from the highest numbered channel to channel 0 and repeats the process. Thus you

can scan any number of channels from eight to two. Notice that the same gain setting is used for all channels in the scan sequence.

The programmable gain amplifier applies gain to the input signal, allowing an analog input signal to be amplified before being sampled and converted, thus increasing measurement resolution and accuracy. The instrumentation amplifier gain is software selectable. The DAQCard-1200 provides gains of 1, 2, 5, 10, 20, 50, and 100.

The dither circuitry, when enabled, adds approximately 0.5 LSB rms of white Gaussian noise to the signal to be converted to the ADC. This addition is useful for applications involving averaging to increase the resolution of the DAQCard-1200 to more than 12 bits, as in calibration. In such applications, which are often lower frequency in nature, noise modulation is decreased and differential linearity is improved by the addition of the dither. For high-speed 12-bit applications not involving averaging, dither should be disabled because it only adds noise.

When taking DC measurements, such as when calibrating the board, enable dither and average about 1,000 points to take a single reading. This process removes the effects of 12-bit quantization and reduces measurement noise, resulting in improved resolution. Dither, or additive white noise, has the effect of forcing quantization noise to become a zero-mean random variable rather than a deterministic function of input. For more information on the effects of dither, see “Dither in Digital Audio,” *Journal of the Audio Engineering Society*.

The DAQCard-1200 uses a 12-bit successive-approximation ADC. The 12-bit resolution of the converter allows the converter to resolve its input range into 4,096 different steps. The ADC has an input range of ± 5 V and 0 to 10 V.

When an A/D conversion is complete, the ADC clocks the result into the A/D FIFO. This FIFO serves as a buffer to the ADC. The A/D FIFO can collect up to 1,024 A/D conversion values before any information is lost, thus allowing software some extra time to catch up with the hardware. If you store more than 1,024 samples in the A/D FIFO before reading from the A/D FIFO, an error condition called *A/D FIFO overflow* occurs and you lose A/D conversion information.

The output from the ADC can be interpreted as either straight binary or two’s complement, depending on which input mode you select (unipolar or bipolar). In unipolar mode, the data from the ADC is interpreted as a 12-bit straight binary number with a range of 0 to +4,095. In bipolar mode, the data from the ADC is interpreted as a 12-bit two’s complement number

with a range of $-2,048$ to $+2,047$. In this mode, the MSB of the ADC result is modified to make it two's complement. The output from the ADC is then sign extended to 16 bits, causing either a leading 0 or a leading F (hex) to be added, depending on the coding and the sign. Thus, data values read from the FIFO are 16 bits wide.

Data Acquisition Timing

A data acquisition operation refers to the process of taking a sequence of A/D conversions when the sample interval (the time between successive A/D conversions) is carefully timed. A data acquisition operation can either acquire a finite number of samples (controlled run) or an infinite number of samples (freerun). The DAQCard-1200 unit can perform both single-channel data acquisition and multiple-channel (scanned) data acquisition in two modes—continuous and interval.

The data acquisition timing circuitry consists of various clocks and timing signals that control the data acquisition operation. Data acquisition timing consists of signals that initiate a data acquisition operation, time the individual A/D conversions, gate the data acquisition operation, and generate scanning clocks. The data acquisition operation can either be timed by the timing circuitry or by externally generated signals. These two modes are software configurable.

Data Acquisition Operation

Data acquisition operations are initiated either externally through EXTTRIG or through software control. The data acquisition operation is terminated either internally by counter A1 of the 82C53(A) counter/timer circuitry, which counts the total number of samples taken during a controlled operation, or through software control in a freerun operation.

Continuous Data Acquisition

In a continuous data acquisition operation, samples are taken at regular sample intervals without any delays. Therefore, each sample is taken with the same sample interval. This applies to both single-channel and multiple-channel data acquisition in either freerun or controlled operation. The sample interval is either controlled externally by EXTCONV* or internally by counter A0 of the timing circuitry.

Interval Data Acquisition

In an interval data acquisition operation, a new period called the *interval cycle* is defined. Within each interval cycle, a predefined number of samples is taken at regular sample intervals and conversions are stopped for the remainder of the interval cycle. A data acquisition operation consists of back-to-back interval cycles. In single-channel interval data acquisition, you select the number of samples you want in each interval cycle from a single channel. In multiple-channel interval data acquisition, the channels are scanned once during each interval cycle. The interval cycle timing can be externally controlled through OUTB1 or controlled internally by counter B1 of the timing circuitry.

For an example of a multiple-channel interval data acquisition operation, refer to the description of interval scanning signal timing in the [DAQ Timing Connections](#) section in Chapter 3, [Signal Connections](#).

Data Acquisition Rates

Maximum data acquisition rates (number of samples per second) are determined by the conversion period of the ADC plus the sample-and-hold acquisition time. During multiple-channel scanning, the data acquisition rates are further limited by the settling time of the input multiplexers and programmable gain amplifier. After the input multiplexers are switched, the amplifier must be allowed to settle to the new input signal value to within 12-bit accuracy before you perform an A/D conversion, or 12-bit accuracy will not be achieved. The settling time is a function of the gain selected.

Table 4-1 shows the recommended settling time for each gain setting during multiple-channel scanning. Table 4-2 shows the maximum recommended data acquisition rates for both single-channel and multiple-channel data acquisition. For single-channel scanning, this rate is limited only by the ADC conversion period plus the sample-and-hold acquisition time, which is specified at 10 μs (11 μs if EXTCONV* is used).

For multiple-channel data acquisition, observing the data acquisition rates in Table 4-2 ensures 12-bit accuracy.

Table 4-1. Analog Input Settling Time Versus Gain

Gain Setting	Settling Time Recommended
1, 2, 5, 10	10 μ s max
20	12 μ s typ, 15 μ s max
50	25 μ s typ, 30 μ s max
100	60 μ s typ, 80 μ s max

Table 4-2. DAQCard-1200 Maximum Recommended Data Acquisition Rates

Acquisition Mode	Gain Setting	Sampling Rate
Single channel	1, 2, 5, 10, 20, 50, 100	100.0 kS/s
Multiple channel	1, 2, 5, 10	100 kS/s
	20	83.3 kS/s
	50	40.0 kS/s
	100	16.6 kS/s

The recommended data acquisition rates in Table 4-2 assume that voltage levels on all the channels included in the scan sequence are within range for the given gain and are driven by low-impedance sources.



Note

If you use external conversions for single-channel acquisitions, the maximum sampling rate is 90 kS/s.

Analog Output

The DAQCard-1200 has two channels of 12-bit D/A output. Each analog output channel can provide unipolar or bipolar output. The DAQCard-1200 also contains timing circuitry for waveform generation timed either externally or internally. Figure 4-5 shows the analog output circuitry.

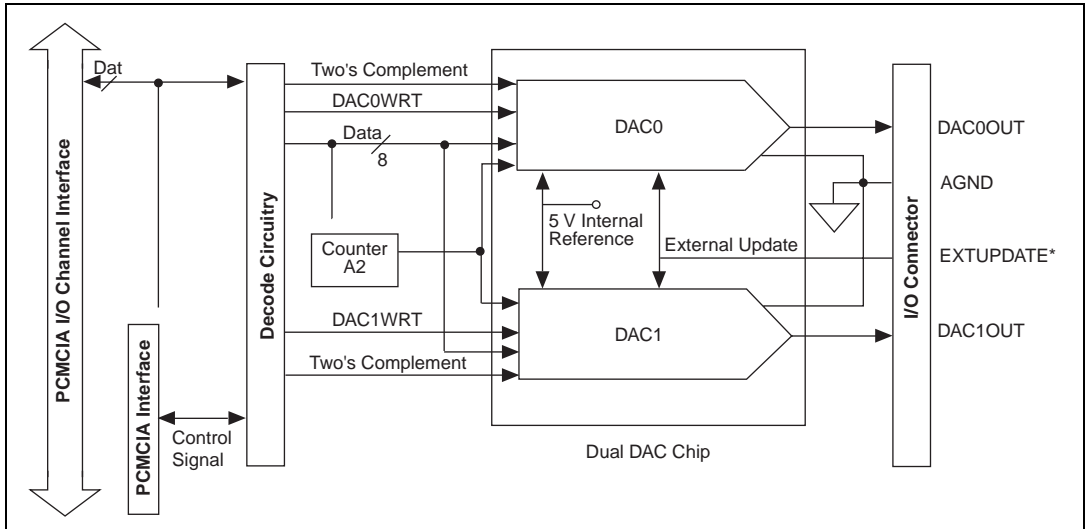

Figure 4-5. Analog Output Circuitry

Analog Output Circuitry

Each analog output channel contains a 12-bit DAC. The DAC in each analog output channel generates a voltage proportional to the 5 V reference (provided in the Dual DAC chip) multiplied by the 12-bit digital code loaded into the DAC. The voltage output from the two DACs is available at the DAQCard-1200 I/O connector DAC0OUT and DAC1OUT pins.

You can program each DAC channel for a unipolar voltage output or a bipolar voltage output range. A unipolar output gives an output voltage range of 0 to +10 V. A bipolar output gives an output voltage range of ± 5 V. For unipolar output, 0 V output corresponds to a digital code word of 0. For bipolar output, -5 V output corresponds to a digital code word of F800 hex. One LSB is the voltage increment corresponding to an LSB change in the digital code word. For both outputs:

$$1 \text{ LSB} = \frac{10 \text{ V}}{4,096}$$

Power-On State

Both analog outputs reach 0 V approximately 110 ms after card insertion. During this 110 ms period, the output voltage can swing from +2 to -5 V.



Warning *Disconnect the analog outputs from the system before inserting the card in the PC Card slot. This step ensures that you do not damage your system during the 110 ms before the output reaches 0 V.*

DAC Timing

There are two ways you can update the DAC voltages. In the first mode, the DAC output voltage is updated as soon as you write to the corresponding DAC. This is called the immediate update mode. In the second mode, the DAC output voltage does not change until a low level is detected either from counter A2 of the timing circuitry or from EXTUPDATE*. This mode is useful for waveform generation. These two modes are software selectable.



Note *Configure both the DACs in either immediate update mode or later update mode. Do not configure the DACs in a combination of both modes because doing so can result in premature updates on the waveform generation DAC (whenever the immediate update DAC is updated). Also, if a waveform generation update occurs between an LSB write and an MSB write of the DAC in the immediate update mode, you will receive an incorrect value from that DAC until the MSB is written. Both of these effects are minimal at high waveform update rates.*

Digital I/O

The digital I/O circuitry has an 82C55A integrated circuit. The 82C55A is a general-purpose programmable peripheral interface (PPI) containing 24 programmable I/O pins. These pins represent the three 8-bit I/O ports (A, B, and C) of the 82C55A, as well as PA<0..7>, PB<0..7>, and PC<0..7> on the DAQCard-1200 I/O connector. Figure 4-6 shows the digital I/O circuitry.

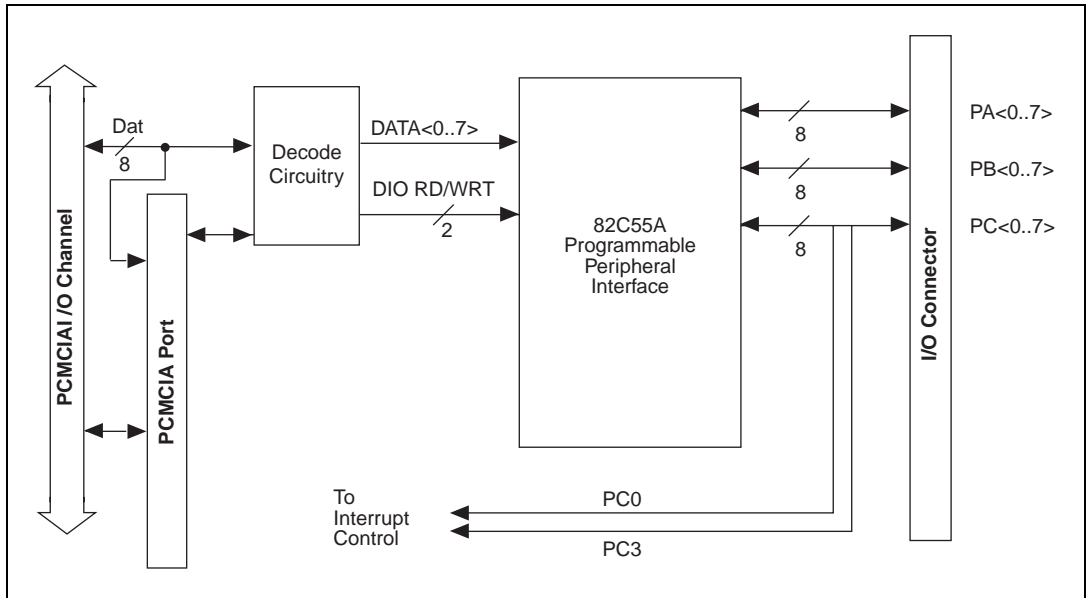

Figure 4-6. Digital I/O Circuitry

All three ports on the 82C55A are TTL-compatible. When enabled, the digital output ports are capable of sinking 2.4 mA of current and sourcing 2.6 mA of current on each digital I/O line. When the ports are not enabled, the digital I/O lines act as high-impedance inputs.

Calibration

This chapter discusses the calibration procedures for the DAQCard-1200 analog I/O circuitry. However, the DAQCard-1200 is factory calibrated, and National Instruments can recalibrate your card if necessary. To maintain the 12-bit accuracy of the DAQCard-1200 analog input and analog output circuitry, recalibrate at 6-month intervals.

There are two ways to perform calibrations.

- Use the NI-DAQ `Calibrate_1200` function. This is the simpler method.
- Use your own register-level writes to the calibration DACs and the EEPROM.

The DAQCard-1200 is software calibrated, so there are no calibration trim pots. The calibration process involves reading offset and gain errors from the analog input and analog output sections and writing values to the appropriate calibration DACs to null the errors. There are four calibration DACs associated with the analog input section and four calibration DACs associated with the analog output section, two for each output channel. After the calibration process is complete, each calibration DAC is at a known value. Because these values are lost when the card is powered down, they are stored in the onboard EEPROM for future reference.

The factory information occupies one half of the EEPROM and is write-protected. The lower half of the EEPROM contains user areas for calibration data. There are four different user areas. When the DAQCard-1200 is powered on, or when the conditions under which it is operating change, you must load the calibration DACs with the appropriate calibration constants.

If you use the DAQCard-1200 with NI-DAQ and LabVIEW or LabWindows/CVI, the factory calibration constants are automatically loaded into the calibration DAC the first time a function pertaining to the DAQCard-1200 is called, and then each time you change your configuration. You can, instead, choose to load the calibration DACs with calibration constants from the user areas in the EEPROM, or you can recalibrate the DAQCard-1200 and load these constants directly into the calibration DACs.

Calibration at Higher Gains

The DAQCard-1200 has a maximum gain error of 0.8%. This means that if the card is calibrated at a gain of 1, and if the gain is switched to 100, a maximum of 32 LSB error may result in the reading. Therefore, when you are recalibrating the DAQCard-1200, you should perform gain calibration at all other gains (2, 5, 10, 20, 50, and 100), and store the corresponding values in the user gain calibration data area of the EEPROM, thus ensuring a maximum error of 0.02% at all gains. The DAQCard-1200 is factory-calibrated at all gains, and NI-DAQ automatically loads the correct values into the calibration DACs whenever you switch gains.

Calibration Equipment Requirements

The equipment you use to calibrate the DAQCard-1200 should have a $\pm 0.001\%$ rated accuracy, which is 10 times as accurate as the DAQCard-1200. However, calibration with only four times the accuracy as the DAQCard-1200 and a $\pm 0.003\%$ rated accuracy is acceptable. The inaccuracy of the calibration equipment results only in gain error; offset error is unaffected.

Calibrate the DAQCard-1200 to a measurement accuracy of ± 0.5 LSBs, which is within $\pm 0.012\%$ of its input range.

For analog input calibration, use a precision DC voltage source, such as a calibrator, with the following specifications.

- Voltage approximately 4 V (bipolar), 9 V (unipolar)
- Accuracy $\pm 0.001\%$ standard
 $\pm 0.003\%$ acceptable

Using the Calibration Function

NI-DAQ contains the `Calibrate_1200` function, with which you can either load the calibration DACs with the factory constants or the user-defined constants stored in the EEPROM, or perform your own calibration and directly load these constants into the calibration DACs. To use the `Calibrate_1200` function for analog input calibration, you must ground an analog input channel at the front connector, for offset calibration, and apply an accurate voltage reference to another input channel, for gain calibration. For analog output calibration, the DAC0 and DAC1 outputs must be wrapped back and applied to two other analog input channels.

When you perform analog input calibration, you must first configure the ADC for referenced single-ended (RSE) mode and for the correct polarity at which you want to perform data acquisition. When you perform analog output calibration, you must first configure the analog input circuitry for RSE and for bipolar polarity, and you must configure the analog output circuitry for the correct polarity at which you want to perform output waveform generation. Refer to the *NI-DAQ Function Reference Manual for PC Compatibles* for more details on the `Calibrate_1200` function.

Specifications

This appendix lists the specifications for the DAQCard-1200. These specifications are typical at 25 °C unless otherwise noted.

Analog Input

Input Characteristics

Number of channels 8 single-ended,
 8 pseudodifferential or
 4 differential, software selectable

Resolution 12 bits, 1 in 4,096

Max single-channel sampling rate 100 kS/s

Input signal ranges

Board Gain (Software Selectable)	Board Range (Software Selectable)	
	Unipolar	Bipolar
1	0 to 10 V	±5 V
2	0 to 5 V	±2.5 V
5	0 to 2 V	±1 V
10	0 to 1 V	±500 mV
20	0 to 500 mV	±250 mV
50	0 to 250 mV	±100 mV
100	0 to 100 mV	±50 mV

Input coupling DC

Type of ADC..... Successive approximation

Maximum working voltage (signal + common mode)	Negative input/AISENSE should remain within ± 6 V (bipolar) or -6 to 2 V (unipolar) of AGND
Overvoltage protection	± 35 V powered on and ± 25 V powered off
Inputs protected	<ACH0..ACH7>
FIFO buffer size.....	1,024 samples
Data transfers	Interrupts, programmed I/O
Dither	Available

Transfer Characteristics

Relative accuracy	± 0.5 LSB typ dithered, ± 1.5 LSB max undithered
DNL	± 1 LSB max
No missing codes.....	12 bits, guaranteed
Offset error	
Pre-gain error after calibration	$10 \mu\text{V}$ max
Pre-gain error before calibration	± 20 mV max
Post-gain error after calibration.....	1 mV max
Post-gain error before calibration....	± 200 mV max
Gain error (relative to calibration reference)	
After calibration.....	0.02% of reading max
Before calibration	$\pm 2\%$ of reading max
Gain $\neq 1$ with gain error adjusted to 0 at gain = 1.....	$\pm 0.8\%$ of reading max

Amplifier Characteristics

Input impedance	
Normal powered on	$100 \text{ G}\Omega$ in parallel with 50 pF
Powered off	$4.7 \text{ k}\Omega$ min
Overload	$4.7 \text{ k}\Omega$ min

Input bias current ± 100 pA
 Input offset current..... ± 100 pA
 CMRR 70 dB, DC to 60 Hz

Dynamic Characteristics

Bandwidth

Small signal (-3 dB)

Gain	Bandwidth
1–10	250 kHz
20	150 kHz
50	60 kHz
100	30 kHz

Settling time to full scale step

Gain	Accuracy
	$\pm 0.024\%$ (± 1 LSB)
1–10	10 μ s max
20	12 μ s typ, 15 μ s max
50	25 μ s typ, 30 μ s max
100	60 μ s typ, 80 μ s max

System noise (not including quantization error)

Gain	Dither Off	Dither On
1–50	0.3 LSBrms	0.5 LSBrms
100	0.5 LSBrms	0.7 LSBrms

Stability

Recommended warm up time	15 minutes
Offset temperature coefficient	
Pre-gain.....	$\pm 15 \mu\text{V}/^\circ\text{C}$
Post-gain	$\pm 100 \mu\text{V}/^\circ\text{C}$
Gain temperature coefficient	$\pm 40 \text{ ppm}/^\circ\text{C}$

Analog Output

Output Characteristics

Number of Channels	2 voltage
Resolution	12 bits, 1 in 4,096
Max update rate	20 kS/s ¹
Type of DAC	Double buffered
Data transfers	Interrupts, programmed I/O

Transfer Characteristics

Relative accuracy (INL)	$\pm 0.5 \text{ LSB typ, } \pm 1 \text{ LSB max}$
DNL	$\pm 0.5 \text{ LSB typ, } \pm 0.9 \text{ LSB max}$
Monotonicity	12 bits, guaranteed
Offset error	
After calibration.....	$\pm 0.5 \text{ mV max}$
Before calibration	$\pm 75 \text{ mV max}$
Gain error (relative to internal reference)	
After calibration.....	$\pm 0.02\% \text{ of reading max}$
Before calibration	$\pm 2\% \text{ of reading max}$

¹ If you perform simultaneous AI and AO, reliable continuous rates are limited to 0.5 to 1 kS/s and is configuration dependent.

Voltage Output

Ranges	0–10 V, ± 5 V software selectable
Output coupling	DC
Output impedance	0.5 Ω typ
Current drive	1 mA max per channel
Protection	80 mA momentary short-circuit protection to ground
Power on state	
0 to 110 ms	+2 V to –5 V
>110 ms	0 V (\pm mV)

Dynamic Characteristics

Settling time to full-scale step	20 μ s to ± 1 LSB accuracy
Noise	400 μ Vrms typ, DC to 1 MHz

Stability

Offset temperature coefficient	± 50 μ V/ $^{\circ}$ C
Gain temperature coefficient	± 30 ppm/ $^{\circ}$ C

Digital I/O

Number of channels	24 I/O (three 8-bit ports; uses the 82C55A PPI)
Compatibility	TTL
Power-on state	All ports high impedance inputs

Digital logic levels

Level	Min	Max
Input low voltage	-0.3 V	0.8 V
Input high voltage	2.2 V	5.3 V
Output low voltage ($I_{out} = 2.5 \text{ mA}$)	—	0.4 V
Output high voltage ($I_{out} = -40 \text{ }\mu\text{A}$) ($I_{out} = -2.5 \text{ mA}$)	4.2 V 3.7 V	— —
Output leakage current $0 \leq V_{out} \leq V_{cc}$	-10 μA	10 μA

Protection-0.5 to 5.5 V powered on,
 $\pm 0.5 \text{ V}$ powered off

Handshaking3 wire, 2 port

Data transfersInterrupts, programmed I/O

Timing I/O

Number of channels3 counters/timers

Digital logic levels

Level	Min	Max
Input low voltage	-0.3 V	0.8 V
Input high voltage	2.2 V	5.3 V
Output low voltage ($I_{out} = 4 \text{ mA}$)	—	0.45 V
Output high voltage ($I_{out} = -1 \text{ mA}$)	3.7 V	—

Protection	-0.5 to 5.5 V powered on, ±0.5 V powered off
Resolution	
Counters/timers	16 bits
Compatibility	TTL
Base clocks available	2 MHz
Base clock accuracy	±50 ppm max
Max source frequency	8 MHz
Min source pulse duration.....	125 ns
Min gate pulse duration.....	100 µs
Data transfers	Interrupts, programmed I/O

Digital Trigger

Compatibility	TTL
Response	Rising edge
Pulse width.....	50 ns min

Bus Interface

Slave

Power Requirement

+5 VDC (±5%).....	150 mA operating, 50 mA power-down mode, plus any current drawn through the I/O connector +5 line.
-------------------	---

Physical

Dimensions.....	8.56 by 5.40 cm (3.37 by 2.13 in.)
PC Card type	Type II
I/O connector.....	50-pin male

Environment

Operating temperature0 to 50 °C

Storage temperature-55 to 150 °C

Relative humidity5% to 90% noncondensing

Differences among the Lab-PC+, the DAQPad-1200, and the DAQCard-1200

This appendix contains a summary of the functional differences among the Lab-PC+, the DAQPad-1200, and the DAQCard-1200.

The Lab-PC+ is a plug-in DAQ board for PCs. It has jumpers for allocating of bus resources such as base address, interrupt, and DMA channels, as well as analog input/output resources such as input/output mode and polarity. It also has potentiometers for calibration.

The DAQPad-1200 is a DAQ device that plugs into the parallel port of the computer. It is functionally identical to the Lab-PC+. In addition, there are no jumpers for bus resource allocation; this is done at configuration time with software. It also has no potentiometers because it is software calibrated. It is a jumperless and a potless unit. The DAQPad-1200 is register-compatible with the Lab-PC+. It has a few additional registers for calibration purposes.

The DAQCard-1200 is register-compatible with the DAQPad-1200 (and the Lab-PC+) and functionally identical to it. Register-level software developed for the Lab-PC+ works directly on a configured DAQCard-1200. However, you calibrate the DAQCard-1200 with software instead of potentiometers.

The following table summarizes the differences among the three products.

Functionality	Lab-PC+	DAQPad-1200	DAQCard-1200
Bus resource allocation	Jumpers	Software	Software (automatic)
Calibration	Potentiometers	Software	Software
DMA	Uses DMA	Cannot use DMA	Cannot use DMA
Waveform generation	Can do waveform generation on one DAC and immediate updates on the other DAC	Can do waveform generation on one DAC and immediate updates on the other	Should do either immediate update on both or waveform generation on both but not a combination. See Chapter 4, <i>Theory of Operation</i> , for more information.
FIFO size	512 samples	1,024 samples	1,024 samples
Maximum single-channel acquisition rate	83.3 K samples/s	100 K samples/s	100 K samples/s
Power-management modes	—	—	150 mA operating, 50 mA power-down mode
Fuse	Regular 250 mA	Regular 250 mA	Thermal 1.0 A



Power-Management Modes

This appendix describes the power-management modes of the DAQCard-1200.

- **Normal Mode**—This is the normal operating mode of the DAQCard-1200 in which all the circuits are fully functional. This mode draws about 150 mA from the 5 V supply (about 750 mW).
- **Power-Down Mode**—In this mode, the digital circuitry is powered on and is functional. The analog input and output circuits are powered down by setting the PWRDOWN bit in the PCMCIA Card Configuration and Status Register. You can set the PWRDOWN bit by using the DAQPOWER utility that is shipped with NI-DAQ. Use DAQPOWER-D to power down and DAQPOWER-U to power up the DAQCard-1200. This utility is also available in Windows and is installed whenever you install NI-DAQ. Typically, the analog supplies are not reduced to zero; negligible power is supplied to the analog circuits. This mode draws about 50 mA from the 5 V supply (about 250 mW).

Table C-1 shows the effects of different power-management modes on the DAQCard-1200 circuits.

Table C-1. DAQCard-1200 Power-Management Modes

	Normal Mode	Power-Down Mode
Analog Input	Functional. Defaults to bipolar (± 5 V) RSE. Protected to ± 35 V. Impedance > 1 G Ω .	Nonfunctional. Draws negligible power. Protected to ± 25 V. Impedance = 4.7 k Ω , which is the input protection resistance.
Analog Output	Functional. Defaults to bipolar (± 5 V) RSE. Output of each DAC remains at 0 V (within 110 ms of card insertion) until the first update is performed on that DAC. Short circuit protected to 80 mA. DC impedance = 0.5 Ω .	Nonfunctional. Draws negligible power. Output of each DAC is ideally 0 V, but may get some negligible value. Short circuit protected to 80 mA. Assume impedance = 0.5 Ω .

Table C-1. DAQCard-1200 Power-Management Modes (Continued)

	Normal Mode	Power-Down Mode
Calibration Circuitry	Functional. Both analog input and analog output can be fully calibrated. The CALDACs default to 0 V.	Nonfunctional. Draws negligible power. 5 V supply is ideally zero, but gets negligible voltage. The CALDACs default to 0 V. Calibration constants (digital values) written into the CALDAC are not preserved and must be rewritten after entering normal mode.
Digital I/O	Functional. Defaults to high impedance inputs for all ports. Protected from -0.5 to 5.5 V.	Functional. Defaults to high impedance inputs for all ports (A, B, and C). Protected from -0.5 to 5.5 V.
Counters	Functional. Initialize to undefined states. Individual counters of the 82C53 must be fully programmed before use. Protected from -0.5 to 5.5 V.	Functional. Initialize to undefined states. Individual counters of the 82C53 must be fully programmed before use. Protected from -0.5 to 5.5 V.

PC Card Questions and Answers

This appendix contains a list of common questions and answers relating to PC Card operation. The questions are grouped according to the type of information requested. You may find this information useful if you are having difficulty with the PC Card system software configuration.

Configuration

1. Do I need to use my PC Card configuration utility to configure the National Instruments PC Cards?

No. We recommend that you do not configure our PC Cards using PC Card Control or an equivalent PC Card configuration utility. Use the configuration utilities included with the NI-DAQ driver software to properly configure your card. The appropriate utilities are `WDAQCONF` for Windows users or `DAQCONF` for DOS users

2. What should I do if my computer does not have Card and Socket Services version 2.0 or later?

Contact the manufacturer of your computer or of your PC Card adapter and request the latest Card and Socket PC Card driver. Our NI-DAQ software will work with any Card and Socket Service driver that is compliant to version 2.0 or higher.

Operation

1. My PC Card works when inserted before power-on time, but it does not work when hot inserted. What is wrong?

You may have an interrupt conflict. If you have a utility such as `MSD.EXE`, run it to determine the allocated interrupts, then refer to question 5 in the [Resources](#) section. `MSD.EXE` is usually shipped with Microsoft Windows.

2. My computer locks up when I use a PC Card. What should I do?

This usually happens because Card Services allocated an unusable interrupt level to the PC Card. For example, on some computers, interrupt level 11 is not routed to PC Cards. If Card Services is not aware of this, it may assign interrupt 11 to a PC Card even though the interrupt is not usable. When a call uses the interrupt, the interrupt never occurs, and the computer locks up waiting for a response. For information about how to locate an interrupt that is free to be used, refer to question 4 in the *Resources* section.

3. Is there a way I can conserve power on my PC Card when it is not in use?

Yes. If you are using NI-DAQ for PC compatibles version 4.8.0 or later, a DOS utility called `DAQPOWER_EXE` will switch all National Instruments PC Cards between normal mode and power-down mode. Power-up and power-down icons are also installed for Windows users to access either of these two power-management modes. Refer to Appendix C, *Power-Management Modes*, for more information on these modes.

Resources

1. How do I determine if I have a memory conflict?

If no PC Cards are working at all, it is probably because a memory window is not usable. Card Services uses a 4 kB memory window for its own internal use. If the memory cannot be used, then Card Services cannot read the Card Information Structure (CIS) from the card's EPROM, which means it cannot identify cards.

There are two different methods you can use when Card Services has a problem reading the CIS. First, you can determine which memory window Card Services is using, and then exclude that window from use by Card Services and/or the memory manager. Second, you can attempt to determine all of the memory that Card Services can possibly use and then exclude all but that memory from use by Card Services.

2. How do I determine all of the memory that Card Services can use?

One way to find out which memory addresses Card Services can use is to run a utility such as `MSD.EXE` that scans the system and tells you how the system memory is being used. For example, if you run such a memory utility and it tells you that physical addresses C0000 to C9FFF

are being used for ROM access, then you know that C8000–D3FFF is an invalid range for Card Services and should be changed to CA000–D3FFF.

3. How can I find usable I/O addresses?

Finding usable I/O addresses is done by trial and error. Of the three resources used—memory, I/O, interrupts—I/O conflicts will be low. You can use either `DAQCONF.EXE` in DOS or `WDAQCONF` in Windows to diagnose I/O space conflicts. When you have configured `DAQCONF` or `WDAQCONF` for a particular I/O space, save the configuration. If there is a conflict, the configuration utility will report an error describing the conflict.

4. How do I find usable interrupt levels?

Some utilities, such as `MSD.EXE`, will scan the system and display information about what is using hardware interrupts. If you have such a utility, you can run it to determine what interrupts Card Services can use. Card Services needs an interrupt for itself as well as one interrupt for each PC Card socket in the system. For example, in a system with two PC Card sockets, at least three interrupts should be allocated for use by Card Services.

Keep in mind that utilities such as `MSD.EXE` will sometimes report that an interrupt is in use when it really is not. For example, if the computer has one serial port, COM1, and one parallel port, LPT1, you know that IRQs 4 and 7 are probably in use. In general, IRQ5 is used for LPT2, but if the computer does not have two parallel ports, IRQ5 should be usable. IRQ3 is used for COM2, but if the computer has only has one serial port, IRQ3 should be usable.

5. I run a memory utility, and it appears there is no memory available for Card Services. What should I do?

You should remove your memory manager by commenting it out of the `CONFIG.SYS` file. Next, you can rerun the memory utility. Memory managers often consume an enormous amount of memory, and you will need to determine what memory is really usable by Card Services. When you have determined what memory is available for Card Services, reinstall your memory manager and make the necessary changes to provide Card Services with the memory needed. We suggest that you use the minimum amount of memory for Card Services, namely 4 to 12 kB, which frees more memory for the memory manager.

Resource Conflicts

1. How do I resolve conflicts between my memory manager and Card Services?

Card Services can usually use memory space that is not being used for real RAM on the system. Even when this is the case, you should still exclude the memory addresses used by Card Services from use by any memory manager that may be installed.

Technical Support Resources

This appendix describes the comprehensive resources available to you in the Technical Support section of the National Instruments Web site and provides technical support telephone numbers for you to use if you have trouble connecting to our Web site or if you do not have internet access.

NI Web Support

To provide you with immediate answers and solutions 24 hours a day, 365 days a year, National Instruments maintains extensive online technical support resources. They are available to you at no cost, are updated daily, and can be found in the Technical Support section of our Web site at www.natinst.com/support.

Online Problem-Solving and Diagnostic Resources

- **KnowledgeBase**—A searchable database containing thousands of frequently asked questions (FAQs) and their corresponding answers or solutions, including special sections devoted to our newest products. The database is updated daily in response to new customer experiences and feedback.
- **Troubleshooting Wizards**—Step-by-step guides lead you through common problems and answer questions about our entire product line. Wizards include screen shots that illustrate the steps being described and provide detailed information ranging from simple getting started instructions to advanced topics.
- **Product Manuals**—A comprehensive, searchable library of the latest editions of National Instruments hardware and software product manuals.
- **Hardware Reference Database**—A searchable database containing brief hardware descriptions, mechanical drawings, and helpful images of jumper settings and connector pinouts.
- **Application Notes**—A library with more than 100 short papers addressing specific topics such as creating and calling DLLs, developing your own instrument driver software, and porting applications between platforms and operating systems.

Software-Related Resources

- **Instrument Driver Network**—A library with hundreds of instrument drivers for control of standalone instruments via GPIB, VXI, or serial interfaces. You also can submit a request for a particular instrument driver if it does not already appear in the library.
- **Example Programs Database**—A database with numerous, non-shipping example programs for National Instruments programming environments. You can use them to complement the example programs that are already included with National Instruments products.
- **Software Library**—A library with updates and patches to application software, links to the latest versions of driver software for National Instruments hardware products, and utility routines.

Worldwide Support

National Instruments has offices located around the globe. Many branch offices maintain a Web site to provide information on local services. You can access these Web sites from www.natinst.com/worldwide.

If you have trouble connecting to our Web site, please contact your local National Instruments office or the source from which you purchased your National Instruments product(s) to obtain support.

For telephone support in the United States, dial 512 795 8248. For telephone support outside the United States, contact your local branch office:

Australia 03 9879 5166, Austria 0662 45 79 90 0, Belgium 02 757 00 20, Brazil 011 284 5011, Canada (Calgary) 403 274 9391, Canada (Ontario) 905 785 0085, Canada (Québec) 514 694 8521, China 0755 3904939, Denmark 45 76 26 00, Finland 09 725 725 11, France 01 48 14 24 24, Germany 089 741 31 30, Greece 30 1 42 96 427, Hong Kong 2645 3186, India 91805275406, Israel 03 6120092, Italy 02 413091, Japan 03 5472 2970, Korea 02 596 7456, Mexico (D.F.) 5 280 7625, Mexico (Monterrey) 8 357 7695, Netherlands 0348 433466, Norway 32 27 73 00, Singapore 2265886, Spain (Barcelona) 93 582 0251, Spain (Madrid) 91 640 0085, Sweden 08 587 895 00, Switzerland 056 200 51 51, Taiwan 02 2377 1200, United Kingdom 01635 523545

Glossary

Prefix	Meanings	Value
p-	pico-	10^{-12}
n-	nano-	10^{-9}
μ -	micro-	10^{-6}
m-	milli-	10^{-3}
k-	kilo-	10^3
M-	mega-	10^6
G-	giga-	10^9
t-	tera-	10^{12}

Numbers/Symbols

° degrees

Ω ohms

% percent

A

A amperes

AC alternating current

ACH analog input channel signal

A/D analog-to-digital

ADC analog-to-digital converter—an electronic device, often an integrated circuit, that converts an analog voltage to a digital number

AIGND analog input ground signal

AWG American Wire Gauge

B

BCD binary-coded decimal

C

C Celsius

CE card enable signal

CLK clock input signal

CMOS complementary metallic oxide semiconductor

CMRR common-mode rejection ratio—a measure of an instrument's ability to reject interference from a common-mode signal, usually expressed in decibels (dB)

D

D/A digital-to-analog

DAQ data acquisition—(1) collecting and measuring electrical signals from sensors, transducers, and test probes or fixtures and inputting them to a computer for processing; (2) collecting and measuring the same kinds of electrical signals with A/D and/or DIO boards plugged into a computer, and possibly generating control signals with D/A and/or DIO boards in the same computer

DC direct current

DGND digital ground signal

DIFF differential configuration

DIN digital input signal

DMA direct memory access—a method by which data can be transferred to/from computer memory from/to a device or memory on the bus while the processor does something else. DMA is the fastest method of transferring data to/from computer memory.

DNL differential nonlinearity—a measure in least significant bit of the worst-case deviation of code widths from their ideal value of 1 LSB

DOUT digital output signal

E

EISA Extended Industry Standard Architecture

ESP Engineering Software Package

EXTCONV external control signal to trigger A/D conversions

EXTINT external interrupt signal

F

F farads

FIFO first-in first-out memory buffer—the first data stored is the first data sent to the acceptor. FIFOs are often used on DAQ devices to temporarily store incoming or outgoing data until that data can be retrieved or output. For example, an analog input FIFO stores the results of A/D conversions until the data can be retrieved into system memory, a process that requires the servicing of interrupts and often the programming of the DMA controller. This process can take several milliseconds in some cases. During this time, data accumulates in the FIFO for future retrieval. With a larger FIFO, longer latencies can be tolerated. In the case of analog output, a FIFO permits faster update rates, because the waveform data can be stored on the FIFO ahead of time. This again reduces the effect of latencies associated with getting the data from system memory to the DAQ device.

G

GATE gate input signal

H

hex	hexadecimal
Hz	hertz—the number of scans read or updates written per second

I

in.	inches
I/O	input/output—the transfer of data to/from a computer system involving communications channels, operator interface devices, and/or data acquisition and control interfaces
ISA	Industry Standard Architecture

L

LED	light-emitting diode
LSB	least significant bit

M

MB	megabytes of memory
MSB	most significant bit

N

NC	not connected (signal)
NRSE	nonreferenced single-ended mode—all measurements are made with respect to a common (NRSE) measurement system reference, but the voltage at this reference can vary with respect to the measurement system ground

O

OUT output signal

P

PCMCIA an expansion bus architecture that has found widespread acceptance as a de facto standard in notebook-size computers. It originated as a specification for add-on memory cards written by the Personal Computer Memory Card International Association.

PPI programmable peripheral interface

R

RAM random-access memory

RMA Return Material Authorization

rms root mean square

S

S samples

s seconds

SCXI Signal Conditioning eXtensions for Instrumentation—the National Instruments product line for conditioning low-level signals within an external chassis near sensors so only high-level signals are sent to DAQ boards in the noisy PC environment

T

TTL transistor-transistor logic

V

V	volts
VCC	positive supply voltage from the PCMCIA bus (usually +5V)
V _{DC}	volts, direct current
VI	virtual instrument—(1) a combination of hardware and/or software elements, typically used with a PC, that has the functionality of a classic stand-alone instrument (2) a LabVIEW software module (VI), which consists of a front panel user interface and a block diagram program
V _{IH}	volts, input high
V _{IL}	volts, input low
V _{in}	volts in
V _{OH}	volts, output high
V _{OL}	volts, output low

Index

Numbers

- +5 V signal (table), 3-4
- 1200_Calibrate function, 5-2 to 5-3

A

- ACH<0..7> signal
 - description (table), 3-3
 - signal ranges, 3-4
 - bipolar and unipolar analog input (table), 3-5
- ACK* signal (table), 3-18
- AGND signal
 - analog input signal connections, 3-4
 - description (table), 3-3
- AISENSE/AIGND signal
 - analog common signal, 3-4
 - description (table), 3-3
- amplifier characteristic specifications, A-2 to A-3
- analog input. *See also* analog input modes;
analog input signal connections.
 - circuitry, 4-6 to 4-8
 - configuration
 - analog I/O settings (table), 2-3
 - default settings, 2-3
 - input modes, 2-4 to 2-5
 - input polarity, 2-3
 - data acquisition rates, 4-9 to 4-10
 - maximum recommended rates (table), 4-10
 - settling time vs. gain (table), 4-10
 - data acquisition timing, 4-8 to 4-9
 - continuous data acquisition, 4-8
 - data acquisition operation, 4-8
 - interval data acquisition, 4-9

- polarity
 - configuration, 2-3
 - settings (table), 2-3
- power-management modes (table), C-1
- specifications, A-1 to A-4
 - amplifier characteristics, A-2 to A-3
 - dynamic characteristics, A-3
 - input characteristics, A-1 to A-2
 - stability, A-4
 - transfer characteristics, A-2
- theory of operation, 4-5 to 4-8
- analog input modes
 - configurations
 - differential connection
 - considerations, 3-7 to 3-8
 - floating signal sources, 3-9 to 3-10
 - ground-referenced signal
 - sources, 3-8 to 3-9
 - recommended input configurations (table), 3-7
- DIFF
 - definition (table), 2-4
 - purpose and use, 2-5
- NRSE
 - definition (table), 2-4
 - purpose and use, 2-5
- RSE
 - definition (table), 2-4
 - purpose and use, 2-4
- analog input signal connections
 - bipolar and unipolar signal range vs. gain (table), 3-5
 - common-mode signal rejection, 3-13 to 3-14
 - differential connections
 - description, 3-7 to 3-8
 - floating signal sources, 3-9 to 3-10

- grounded signal sources, 3-8 to 3-9
- single-ended connections, 3-11 to 3-13
- when to use, 3-8
- exceeding maximum input voltage ratings (warning), 3-4
- floating signal sources, 3-6
- ground-referenced signal sources, 3-6 to 3-7
- input configurations, 3-7 to 3-14
- instrumentation amplifier, 3-5 to 3-6
- pins, 3-4
- recommended input configurations (table), 3-7
- single-ended connections
 - floating signal sources (RSE configuration), 3-11 to 3-12
 - grounded signal sources (NRSE configuration), 3-12 to 3-13
 - purpose and use, 3-11
 - when to use, 3-11
- types of signal sources, 3-6 to 3-7
- analog output
 - circuitry, 4-11
 - DAC timing, 4-12
 - polarity
 - configuration, 2-5 to 2-6
 - settings (table), 2-5
 - power-management modes (table), C-1
 - power-on state, 4-12
 - signal connections, 3-14
 - specifications, A-4 to A-5
 - dynamic characteristics, A-5
 - output characteristics, A-4
 - stability, A-5
 - transfer characteristics, A-4
 - voltage output, A-5
 - theory of operation, 4-11 to 4-12

B

- bus interface specifications, A-7

C

- calibration, 5-1 to 5-3
 - EEPROM storage, 5-1
 - equipment requirements, 5-2
 - higher gains, 5-2
 - overview, 5-1
 - power-management modes (table), C-2
 - using the 1200_Calibrate function, 5-2 to 5-3
- CLK signals
 - general-purpose timing signal connections, 3-26 to 3-30
 - timing requirements signals (figure), 3-30
- CLKB1 signal (table), 3-4
- CLKB2 signal (table), 3-4
- common mode signal rejection considerations, 3-13 to 3-14
- configuration
 - analog input
 - analog I/O settings (table), 2-3
 - default settings, 2-3
 - exceeding maximum ratings (warning), 2-3
 - input modes, 2-4 to 2-5
 - input polarity, 2-3
 - analog output polarity, 2-5 to 2-6
 - counter/timers, 2-6
 - digital I/O, 2-6
 - PC Card, D-1
 - typical configuration (figure), 2-2
- Counter 0 on 82C53(A) counter/timer, 3-22
- Counter 1 on 82C53(A) counter/timer, 3-22
- counter/timers
 - configuration, 2-6
 - power-management modes (table), C-2
 - theory of operation, 4-3 to 4-5

D

DAC OUTPUT UPDATE signal, 3-25 to 3-26

DAC00OUT signal (table), 3-3

DAC1OUT signal (table), 3-3

DACWRT signal, 3-26

DAQ and general-purpose timing signal connections

DAQ timing connections, 3-22 to 3-26

general-purpose timing connections, 3-26 to 3-30

pins, 3-22

power connections, 3-31

DAQ timing connections. *See* data acquisition timing connections.

DAQCard-1200

block diagram, 4-1

configuration. *See* configuration.

differences between Lab-PC+, DAQPad-1200, and DAQCard-1200, B-1 to B-2

installation, 2-1

optional equipment, 1-5

overview and features, 1-1 to 1-2

power-management modes, C-1 to C-2

requirements for getting started, 1-2

software programming choices, 1-2 to 1-4

LabVIEW and LabWindows/CVI application software, 1-3

NI-DAQ driver software, 1-3 to 1-4

register-level programming, 1-4

theory of operation. *See* theory of operation.

unpacking, 1-5

DAQPad-1200, compared with Lab-PC+ and DAQCard-1200, B-1 to B-2

data acquisition rates, 4-9 to 4-10

maximum recommended rates (table), 4-10

settling time *vs.* gain (table), 4-10

data acquisition timing circuitry, 4-8 to 4-9

continuous data acquisition, 4-8

data acquisition operation, 4-8

interval data acquisition, 4-9

data acquisition timing connections, 3-22 to 3-26. *See also* general-purpose timing signal connections.

EXTCONV* signal, 3-22 to 3-24

EXTTRIG signal, 3-22 to 3-24

EXTUPDATE* signal, 3-25 to 3-26

interval scanning, 3-24

multiple-channel interval scanning (figure), 3-25

pins, 3-22

posttrigger and pretrigger modes, 3-23

posttrigger timing (figure), 3-23

pretrigger timing (figure), 3-24

sample counter, 3-22

sample-interval counter, 3-22

waveform generation timing sequence, 3-25 to 3-26

DATA signal (table), 3-18

DGND signal (table), 3-3, 3-4

diagnostic resources, online, E-1

DIFF input

configuration, 2-5

definition (table), 2-4

recommended input configurations (table), 3-7

differential connections

description, 3-7 to 3-8

DIFF configuration considerations, 3-7 to 3-8

floating signal sources, 3-9 to 3-10

ground-referenced signal sources, 3-8 to 3-9

when to use, 3-8

digital I/O

circuitry, 4-13

configuration, 2-6

power-management modes (table), C-2

specifications, A-5 to A-6

digital I/O signal connections

- illustration, 3-16
- pins, 3-15
- Port C pin connections, 3-17
- timing specifications, 3-18 to 3-21
 - mode 1 input timing, 3-19
 - mode 1 output timing, 3-20
 - mode 2 bidirectional timing, 3-20 to 3-21

documentation

- conventions used in manual, *x*
- National Instruments documentation, *xi*
- organization of manual, *ix-x*
- related documentation, *xii*

dynamic characteristics

- analog input specifications, A-3
- analog output specifications, A-5

E

EEPROM storage of calibration data, 5-1

environment specifications, A-8

equipment, optional, 1-5

event-counting application, 3-27

- with external switch gating (figure), 3-27

EXTCONV* signal

- description (table), 3-3
- interval scanning data acquisition, 3-24
- maximum voltage input rating, 3-26
- timing connections, 3-22 to 3-24

EXTTRIG signal

- data acquisition timing, 3-22 to 3-24
- description (table), 3-3
- maximum voltage input rating, 3-26

EXTUPDATE* signal

- data acquisition timing, 3-25 to 3-26
- description (table), 3-3
- maximum voltage input rating, 3-26
- updating DAC output (figure), 3-26

F

floating signal sources

- differential connections, 3-9 to 3-10
- purpose and use, 3-6
- single-ended connections (RSE configuration), 3-11 to 3-12

frequency measurement

- general-purpose timing signal connections, 3-28
- illustration, 3-29

G

GATB0 signal (table), 3-3

GATB1 signal (table), 3-3

GATB2 signal (table), 3-4

GATE signals

- general-purpose timing signal connections, 3-26 to 3-30
- timing requirements signals (figure), 3-30

general-purpose timing signal connections.

See also data acquisition timing connections.

- event-counting, 3-27

- frequency measurement, 3-28

- GATE, CLK, and OUT signals, 3-26 to 3-30

- pins, 3-22

- pulse generation, 3-27

- pulsedwidth measurement, 3-28

- square wave generation, 3-27

- time-lapse measurement, 3-28

- timing requirements for GATE, CLK, and OUT signals (figure), 3-30

ground-referenced signal sources

- differential connections, 3-8 to 3-9
- purpose and use, 3-6 to 3-7
- recommended input configurations (table), 3-7
- single-ended connections (NRSE configuration), 3-12 to 3-13

I

- IBF signal (table), 3-18
- input configurations
 - differential connection
 - considerations, 3-7 to 3-8
 - floating signal sources
 - differential connections, 3-9 to 3-10
 - recommended input configurations (table), 3-7
 - ground-referenced signal sources
 - differential connections, 3-8 to 3-9
 - recommended input configurations (table), 3-7
- installation
 - DAQCard-1200, 2-1
 - unpacking the DAQCard-1200, 1-5
- instrumentation amplifier, 3-5 to 3-6
- interval scanning data acquisition
 - description, 3-24
 - multiple-channel interval scanning (figure), 3-25
- INTR signal (table), 3-18
- I/O connector
 - exceeding maximum ratings (warning), 3-1
 - pin assignments (figure), 3-2

L

- Lab-PC+, compared with DAQPad-1200 and DAQCard-1200, B-1 to B-2
- LabVIEW and LabWindows/CVI application software, 1-3

M

- manual. *See* documentation.
- mode 1 input timing, 3-19
- mode 1 output timing, 3-20
- mode 2 bidirectional timing, 3-20 to 3-21

N

- National Instruments Web support, E-1 to E-2
- NI-DAQ driver software, 1-3 to 1-4
- NRSE input
 - configuration, 2-5
 - definition (table), 2-4
 - recommended input configurations (table), 3-7
 - single-ended connections for
 - ground-referenced signal sources, 3-12 to 3-13

O

- OBF* signal (table), 3-18
- online problem-solving and diagnostic resources, E-1
- operation of DAQCard-1200. *See* theory of operation.
- optional equipment, 1-5
- OUT signals
 - general-purpose timing signal
 - connections, 3-26 to 3-30
 - timing requirements signals (figure), 3-30
- OUTB0 signal (table), 3-3
- OUTB1 signal
 - DAQ timing connections, 3-24
 - description (table), 3-3
 - maximum voltage input rating, 3-26
- OUTB2 signal (table), 3-4

P

- PA<0..7> signals
 - description (table), 3-3
 - digital I/O signal connections, 3-15
- PB<0..7> signals
 - description (table), 3-3
 - digital I/O signal connections, 3-15

PC Card

- configuration, D-1
- I/O channel interface circuitry
 - block diagram, 4-2
 - theory of operation, 4-2 to 4-3
- operation, D-1 to D-2
- resource conflicts, D-4
- resources, D-2 to D-3

PC<0..7> signals

- description (table), 3-3
- digital I/O signal connections, 3-15

physical specifications, A-7

pin assignments for I/O connector (figure), 3-2

polarity

- analog input, 2-3
- analog output, 2-6
- bipolar and unipolar signal range vs. gain (table), 3-5

Port C signal assignments (table), 3-17

posttrigger data acquisition timing (figure), 3-23

posttrigger mode, 3-23

power connections, 3-31

power requirement specifications, A-7

power-management modes

- circuitry effects (table), C-1 to C-2
- normal mode, C-1
- power-down mode, C-1

power-on state, 4-12

pretrigger data acquisition timing (figure), 3-24

pretrigger mode, 3-23

problem-solving and diagnostic resources, online, E-1

pulse generation, 3-27

pulsewidth measurement, 3-28

R

RD* signal (table), 3-18

referenced single-ended mode. *See* RSE input.

register-level programming, 1-4

requirements for getting started, 1-2

RSE input

- configuration, 2-4
- definition (table), 2-4
- recommended input configurations (table), 3-7
- single-ended connections for floating signal sources, 3-11 to 3-12

S

sample counter, 3-22

sample-interval counter, 3-22

sampling rate (note), 4-10

signal connections

analog input signal connections

- bipolar and unipolar signal range vs. gain (table), 3-5

common-mode signal rejection, 3-13 to 3-14

differential connections, 3-7 to 3-8

floating signal sources, 3-9 to 3-10

grounded signal sources, 3-8 to 3-9

single-ended connections, 3-11 to 3-13

when to use, 3-8

exceeding maximum input voltage ratings (warning), 3-4

floating signal sources, 3-6

ground-referenced signal sources, 3-6 to 3-7

input configurations, 3-7 to 3-14

instrumentation amplifier, 3-5 to 3-6

- pins, 3-4
- recommended input configurations (table), 3-7
- single-ended connections
 - floating signal sources (RSE configuration), 3-11 to 3-12
 - grounded signal sources (NRSE configuration), 3-12 to 3-13
 - when to use, 3-11
- types of signal sources, 3-6 to 3-7
- analog output signal connections, 3-14
- DAQ and general-purpose timing signal connections
 - data acquisition timing connections, 3-22 to 3-26
 - general-purpose timing connections, 3-26 to 3-30
 - pins, 3-22
 - power connections, 3-31
- digital I/O signal connections
 - illustration, 3-16
 - pins, 3-15
 - Port C pin connections, 3-17
 - timing specifications, 3-18 to 3-21
 - mode 1 input timing, 3-19
 - mode 1 output timing, 3-20
 - mode 2 bidirectional timing, 3-20 to 3-21
- I/O connector
 - exceeding maximum ratings (warning), 3-1
 - pin assignments (figure), 3-2
 - signal descriptions (table), 3-3 to 3-4
- signal descriptions, 3-3 to 3-4
- single-ended connections
 - floating signal sources (RSE configuration), 3-11 to 3-12
 - ground-referenced signal sources (NRSE configuration), 3-12 to 3-13
 - when to use, 3-11

- software programming choices, 1-2 to 1-4
 - LabVIEW and LabWindows/CVI, 1-3
 - NI-DAQ driver software, 1-3 to 1-4
 - register-level programming, 1-4
- software-related resources, E-2
- specifications
 - analog input, A-1 to A-4
 - amplifier characteristics, A-2 to A-3
 - dynamic characteristics, A-3
 - input characteristics, A-1 to A-2
 - stability, A-4
 - transfer characteristics, A-2
 - analog output, A-4 to A-5
 - dynamic characteristics, A-5
 - output characteristics, A-4
 - stability, A-5
 - transfer characteristics, A-4
 - voltage output, A-5
 - bus interface, A-7
 - digital I/O, A-5 to A-6
 - environment, A-8
 - physical, A-7
 - power requirements, A-7
 - timing I/O, A-6 to A-7
- square wave generation, 3-27
- stability
 - analog input specifications, A-4
 - analog output specifications, A-5
- STB* signal (table), 3-18

T

- technical support resources, E-1 to E-2
- theory of operation
 - analog input, 4-5 to 4-8
 - circuitry, 4-6 to 4-8
 - data acquisition rates, 4-9 to 4-10
 - data acquisition timing, 4-8 to 4-9

- analog output, 4-11 to 4-12
 - circuitry, 4-11
 - DAC timing, 4-12
 - power-on state, 4-12
- block diagram of DAQCard-1200, 4-1
- digital I/O, 4-13
- functional overview, 4-1 to 4-2
- PC card I/O channel interface
 - circuitry, 4-2 to 4-3
 - timing, 4-3 to 4-5
- time-lapse measurement, 3-28
- timing circuitry
 - illustration, 4-4
 - theory of operation, 4-3 to 4-5
- timing I/O specifications, A-6 to A-7
- timing signal connections. *See* data acquisition
 - timing connections; general-purpose timing signal connections.
- timing specifications, digital I/O, 3-18 to 3-21
 - mode 1 input timing, 3-19
 - mode 1 output timing, 3-20
 - mode 2 bidirectional timing, 3-20 to 3-21

- transfer characteristics
 - analog input specifications, A-2
 - analog output specifications, A-4

U

- unpacking the DAQCard-1200, 1-5

V

- voltage output specifications, A-5

W

- Web support from National Instruments,
 - E-1 to E-2
 - online problem-solving and diagnostic resources, E-1
 - software-related resources, E-2
- Worldwide technical support, E-2
- WRT* signal (table), 3-18