

---

# MultiConnect™ Adapter

*Serial-to-Ethernet Adapter with IP*



## User Guide

---

**MultiConnect™ Adapter User Guide  
Serial-to-Ethernet Adapter (MTS2EA & MTS2EA-R)**

**PN S000344D, Version D**

**Copyright**

This publication may not be reproduced, in whole or in part, without prior expressed written permission from Multi-Tech Systems, Inc. All rights reserved.

Copyright © 2003-5, by Multi-Tech Systems, Inc.

Multi-Tech Systems, Inc. makes no representations or warranties with respect to the contents hereof and specifically disclaims any implied warranties of merchantability or fitness for any particular purpose. Furthermore, Multi-Tech Systems, Inc. reserves the right to revise this publication and to make changes from time to time in the content hereof without obligation of Multi-Tech Systems, Inc. to notify any person or organization of such revisions or changes.

**Revisions**

<b>Revision Level</b>	<b>Date</b>	<b>Description</b>
<b>A</b>	05/17/04	Initial release for the Serial-to-Ethernet Adapter.
<b>B</b>	07/12/04	Changed the Installation chapter. Chapter 9 correction of the <i>Data-bits</i> to <i>Stop-bits</i> .
<b>C</b>	10/15/04	Added new features (FTP Client, SNMP Agent, SMTP Client, MCSI AG Server, HTTP Server, RAW TCP/UDP Socket Interface). Changed package contents and connection drawings.
<b>D</b>	05/11/05	Added more graphics to Connections sections. Added more power pin text. . Removed the Command Line Interface section and the Application Examples from this document. Users should see the the common Command Line Interface and Application Examples (S000278x).

**Trademarks**

MultiConnect, Multi-Tech, Multi-Tech Systems, Inc., and the Multi-Tech logo.

All other products or technologies are the trademarks or registered trademarks of their respective holders.

**Patents**

This device is covered by one or more of the following patents: 6,031,867; 6,012,113; 5,628,030; 5,450,425. Other patents pending.

**World Headquarters**

Multi-Tech Systems, Inc.  
2205 Woodale Drive  
Mounds View, Minnesota 55112  
Phone: 763-785-3500 or 800-328-9717  
Fax: 763-785-9874

**Technical Support**

**Country**

France:

India:

U.K.:

U.S. and Canada:

Rest of the World:

**By Email**

support@multitech.fr

support@multitechindia.com

support@multitech.co.uk

oemsales@multitech.com

oemsales@multitech.com

**By Phone**

(33) 1-64 61 09 81

91 (124) 6340778

(44) 118 959 7774

(800) 972-2439

(763) 717-5863

Internet Address: <http://www.multitech.com>

# Table of Contents

<b>Chapter 1 – Product Description &amp; Specifications</b> .....	<b>4</b>
Product Description.....	4
Applications.....	4
Types of Adapters Available .....	5
Package Contents.....	5
Handling Precautions.....	5
Specifications.....	6
LED Indicators.....	8
<b>Chapter 2 – Installation</b> .....	<b>9</b>
Attaching the MultiConnect to a Fixed Location .....	9
Installation.....	10
<b>Chapter 3 – Managing and Configuring the MultiConnect Adapter</b> .....	<b>12</b>
Two Ways to Login.....	12
About Data Mode and Command Mode.....	12
Device Port.....	12
<b>Chapter 4 – AT Commands</b> .....	<b>13</b>
<b>Chapter 5 – Auto-Discovery Manager</b> .....	<b>14</b>
Introduction .....	14
<b>Chapter 6 – Upgrading the Firmware and Flash</b> .....	<b>17</b>
Upgrading the Firmware.....	17
Using Windows TFTP to Upgrade.....	17
Obtaining the Latest Firmware Version .....	17
Upgrading the Flash.....	18
<b>Appendix A – Regulatory Information</b> .....	<b>19</b>
<b>Appendix B – Warranty and Service</b> .....	<b>20</b>
<b>Index</b> .....	<b>22</b>

# Chapter 1 – Product Description & Specifications

## Product Description

The MultiConnect Adapter is a complete, ready to deploy serial-to-Ethernet Adapter for connecting legacy devices to an IP network for remote monitoring, control and configuration. The Adapter provides a high performance Ethernet bridge as well as a complete TCP/IP protocol stack. MultiConnect can make your existing and next generation device, machine, or system IP-ready while you focus on developing its core features.

**Serial-to-Ethernet Technology.** MultiConnect provides the powerful ability to IP-enable legacy serial devices allowing more options for data acquisition, device management, and industrial control than would otherwise be available. The MultiConnect includes a processor, operating system, TCP/IP stack, Web server, and a network connection to provide a complete serial-to-Ethernet bridge.

**Internet-Enable Any Device.** MultiConnect allows you to network-enable virtually any serial device. Using embedded Internet protocols and a connection to an IP network, MultiConnect sends and receives data over the Internet or Intranet connection.

**Reduces Development Time.** MultiConnect can make your existing and next generation serial device IP-ready without requiring hardware changes to its design. MultiConnect actually provides faster time-to-market because it relieves the burden and expense of writing and maintaining Internet applications. The complete, ready-to-integrate MultiConnect Adapter allows you to enhance your product while you focus on developing its core features.

**Management and Configuration.** MultiConnect has several means of management and configuration built into the design. It supports remote configuration, which means you can have central site setup and control of the remote Adapters via the command line interface or telnet.

## Applications

The MultiConnect Adapters will IP-enable any device to provide remote monitoring, control and configuration of any system. The solution is ideal for the following applications:

- Appliances
- ATM terminals
- Credit card and check verification systems
- Data collection
- Gas pumps
- Industrial and medical remote monitoring systems
- Point-of-sale terminals
- Remote diagnostics
- Remote metering
- Security systems
- Ticketing machines
- Vending/gaming machines
- And more.....

## Types of Adapters Available

Product	Adapter Description	Region
<b>MTS2EA</b>	Serial-to-Ethernet + IP (Externally Power)	Global
<b>MTS2EA-R</b>	Serial-to-Ethernet + IP (RS-232 Power)	Global
<b>Note:</b> The <b>MTS2EA-R (RS-232 Powered) Adapter</b> requires power to be supplied into Pin 6 of the female DB9.		

## Package Contents

- One MultiConnect Serial-to-Ethernet Adapter
- One universal power supply with power cord included (included for the MTS2EA build; not included for the MTS2EA-R build)
- One RS-232 cable
- Two mounting brackets
- Four adhesive-backed rubber feet (table-top mounting)
- One Quick Start Guide
- One MultiConnect CD

## Handling Precautions

All devices must be handled with certain precautions to avoid damage due to the accumulation of static charge. Although input protection circuitry has been incorporated into the devices to minimize the effect of this static buildup, proper precautions should be taken to avoid exposure to electrostatic discharge during handling and mounting.

# Specifications

Category	Description																		
Memory	8 MEG																		
Flash Memory	2 MEG																		
Protocols Supported	ARP, DHCP, Telnet, UDP, TFTP, PPP, HTTP, SMTP, POP3, FTP, SNTP, RAW UDP/TCP, ICMP, IP, TCP, SNMP																		
WAN Interface	10/100BaseT Ethernet																		
Serial Interface	Standard DCE Serial																		
Data Formats	Serial, binary, asynchronous																		
Data Rates	300; 1200; 2400; 4800; 9600; 19200; 38400; 57600; 115200; 230400 bps																		
Flow Control	RTS/CTS (hardware)																		
Management	Serial; Telnet; Web																		
Security	Username and password authentication using local database																		
System Software	Flash ROM standard: downloadable from a TCP/IP host (TFTP) or Xmodem via Serial																		
LEDs	Link, Activity, Speed, Status, Power																		
Ethernet	IEEE 802.3																		
Power Requirements	<p><b>With External Power (MTS2EA) Power Consumption</b></p> <table> <tr> <td>@ 9V DC:</td> <td>Typical 250mA</td> <td>Maximum 305mA</td> </tr> </table> <p><b>With RS-232 Power (MTS2EA-R) Power Consumption</b></p> <table> <tr> <td>@ 5V DC:</td> <td>Typical 190mA</td> <td>Maximum 245mA</td> </tr> <tr> <td>@ 10V DC:</td> <td>Typical 100mA</td> <td>Maximum 120mA</td> </tr> <tr> <td>@ 15V DC:</td> <td>Typical 69mA</td> <td>Maximum 83mA</td> </tr> <tr> <td>@ 20V DC:</td> <td>Typical 54mA</td> <td>Maximum 65mA</td> </tr> <tr> <td>@ 25V DC:</td> <td>Typical 45mA</td> <td>Maximum 55mA</td> </tr> </table>	@ 9V DC:	Typical 250mA	Maximum 305mA	@ 5V DC:	Typical 190mA	Maximum 245mA	@ 10V DC:	Typical 100mA	Maximum 120mA	@ 15V DC:	Typical 69mA	Maximum 83mA	@ 20V DC:	Typical 54mA	Maximum 65mA	@ 25V DC:	Typical 45mA	Maximum 55mA
@ 9V DC:	Typical 250mA	Maximum 305mA																	
@ 5V DC:	Typical 190mA	Maximum 245mA																	
@ 10V DC:	Typical 100mA	Maximum 120mA																	
@ 15V DC:	Typical 69mA	Maximum 83mA																	
@ 20V DC:	Typical 54mA	Maximum 65mA																	
@ 25V DC:	Typical 45mA	Maximum 55mA																	
Operating Temperature	32° to +104°F (0° to 40°C); humidity range 25-85% (non-condensing)																		
Storage Temperature	-40°C to +85°C																		
Physical Dimensions	3.5" w x 2.1" h x 0.98" d; 3.4 oz. 8.8 cm x 5.3 cm x 6 cm; 96 g																		
Certifications	<p><b>Safety Certifications:</b></p> <ul style="list-style-type: none"> <li>UL60950</li> <li>cUL60950</li> <li>EN60950</li> <li>ACA TS001 / AS 3260</li> </ul> <p><b>EMC Safety Approvals:</b></p> <ul style="list-style-type: none"> <li>FCC Part 15 Class A</li> <li>EN55022</li> <li>EN55024</li> </ul> <p><b>CE Marked</b></p>																		

Category	Description
<b>Intelligent Features</b>	<p>High performance 10/100BaseT Ethernet bridge  Half duplex or full duplex support on the WAN interface  256 frame buffer  Stores 10,000 MAC addresses  Automatically learns MAC addresses  Serial interface supports DTE speeds to 230K bps  External and RS-232 power options  High performance processor runs the protocols  Command line interface  Flash memory to update firmware with the latest enhancements  Flexible IP protocol stack  Compact, rugged industrial chassis design with desktop or panel mounting  Two-year warranty</p>
<b>Software Features</b>	<p><b>Internet Applications</b></p> <p><b>DHCP Client:</b>  Request IP address for Ethernet Interfaces</p> <p><b>Telnet Server:</b>  Command Line Configuration  Auto Dial-out Feature  Command line via custom port (other than standard port 23)</p> <p><b>Telnet Client:</b>  Connect to remote Telnet Server  Serial Auto Dial-in Feature</p> <p><b>UDP Server:</b>  Auto Dialout Feature with UDP Server support</p> <p><b>UDP Client:</b>  Serial Auto Dial-in Feature with UDP Client support</p> <p><b>Terminal Server:</b>  Network to Serial Connectivity  Serial to Network Connectivity</p> <p><b>TFTP Server:</b>  Flash Upgrade</p> <p><b>SMTP Client:</b>  The email client embedded in the MultiConnect sends email to the configured recipients.  Daylight savings mode feature.</p> <p><b>SNMP Agent:</b>  The SNMP Agent is used to configure the MultiConnect module or view the module's configuration or statistics using the SNMP manager compiled with proprietary MIB.</p> <p><b>RAW UDP/TCP Socket Support via Serial:</b>  Commands to simulate the BSD system calls of UDP and TCP which can be used to build a proprietary protocol on the serial device. Also to switch between the sockets in a single session.  Supports to open, flush, send, receive, close, view statistics of TCP and UDP sockets via Serial.  Supports both Client and Server modes for TCP and UDP.</p> <p><b>POP3 Client:</b>  The email client embedded in the MultiConnect receives email from the POP3 Server. This feature is useful for field upgrades. Firmware upgrades can be sent as attachments.</p> <p><b>HTTP Server:</b>  To host Web pages on behalf of the serial device for monitoring and configuration of the serial device.  Viewing configuration or statistics support.</p> <p><b>FTP Client:</b>  FTP Client embedded in the MultiConnect module lists the directory contents or sends/receives text/binary files to/from a remote server respectively. This feature is useful for field upgrades, etc. Firmware upgrades can be sent or received via FTP transfer. It also supports passive mode connection.</p>

Category	Description
<b>Software Features</b> (continued)	<b>Functional Features</b> <b>Command Line Configuration over Serial or Ethernet</b> Serial – TTY Ethernet – Telnet – Web <b>Username and Password Authentication Using Local Database</b> The Username and Password can be created using commands. The User database authenticates the Users before access to command mode of the MultiConnect Adapter is enabled. <b>Remote Transparent Bridging</b> Ethernet-to-Serial Bridging <b>Point-to-Point Protocol (PPP)</b> Negotiations Bridging Control Protocol 802.3 MAC Type CCP Compression <b>Discovery Support and IP Module Port Capture Using WinMCSI Port Redirector</b> The Serial-to-Ethernet Adapter can be discovered by new WinMCSI Port Redirector software on windows and the serial status can be viewed using WinMCSI Client. The Serial-to-Ethernet Adapter's serial port can be captured using any terminal application after creating and mapping a virtual port.

## LED Indicators

Name	Description
<b>LNK</b>	Link – Lit when data connection has been established.
<b>ACT</b>	Activity – Lit when data is being transmitted or received.
<b>SPD</b>	Speed – Lit when the speed is 100 Mbps. Off for 10 Mbps.
<b>STS</b>	Status – Blinks to indicate that the unit is functioning.
<b>PWR</b>	Power – Lit when the Adapter is turned on.



## Chapter 2 – Installation

### Attaching the MultiConnect to a Fixed Location

The MultiConnect Adapter is design to be used on the desktop or to be panel-mounted. To attach the bracket for panel-mounting, following these steps:

1. Typically, the MultiConnect Adapter is mounted against a flat surface with two mounting screws. Drill the mounting holes at the desired location. The mounting holes must separated by  $4 \frac{7}{16}$  inches center-to-center.

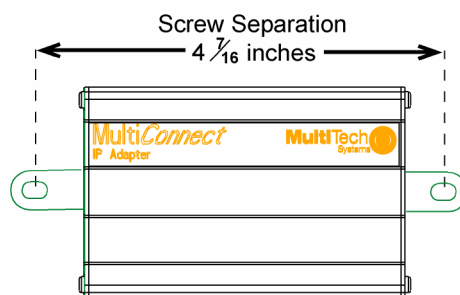

2. To attach the brackets to the MultiConnect, slide the mounting brackets into the corresponding slots on the back of the MultiConnect chassis.

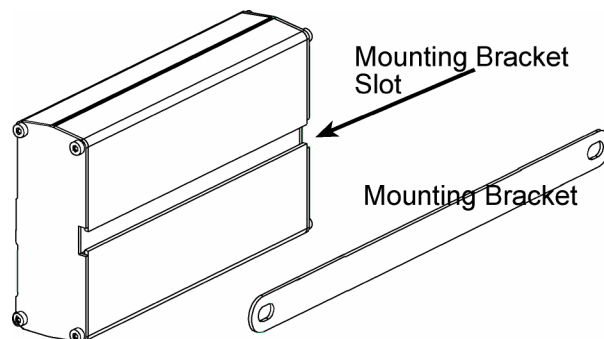

3. Attach the Adapter to the surface with two screws.

# Installation

This is an example of a typical setup.

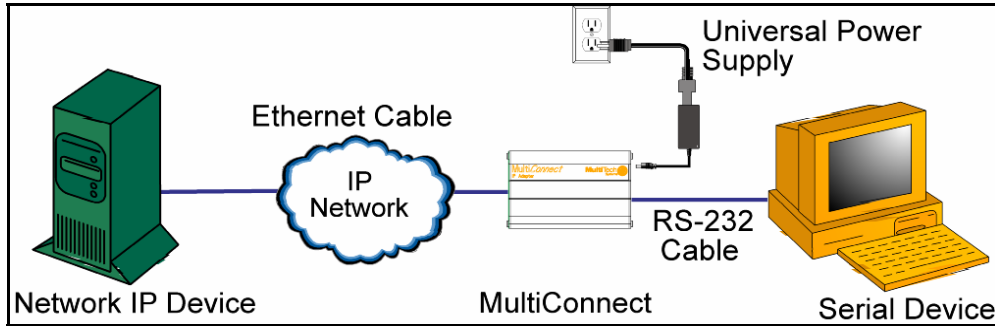

## Serial-to-Ethernet Power Connections

The Adapters are powered in one of two ways:

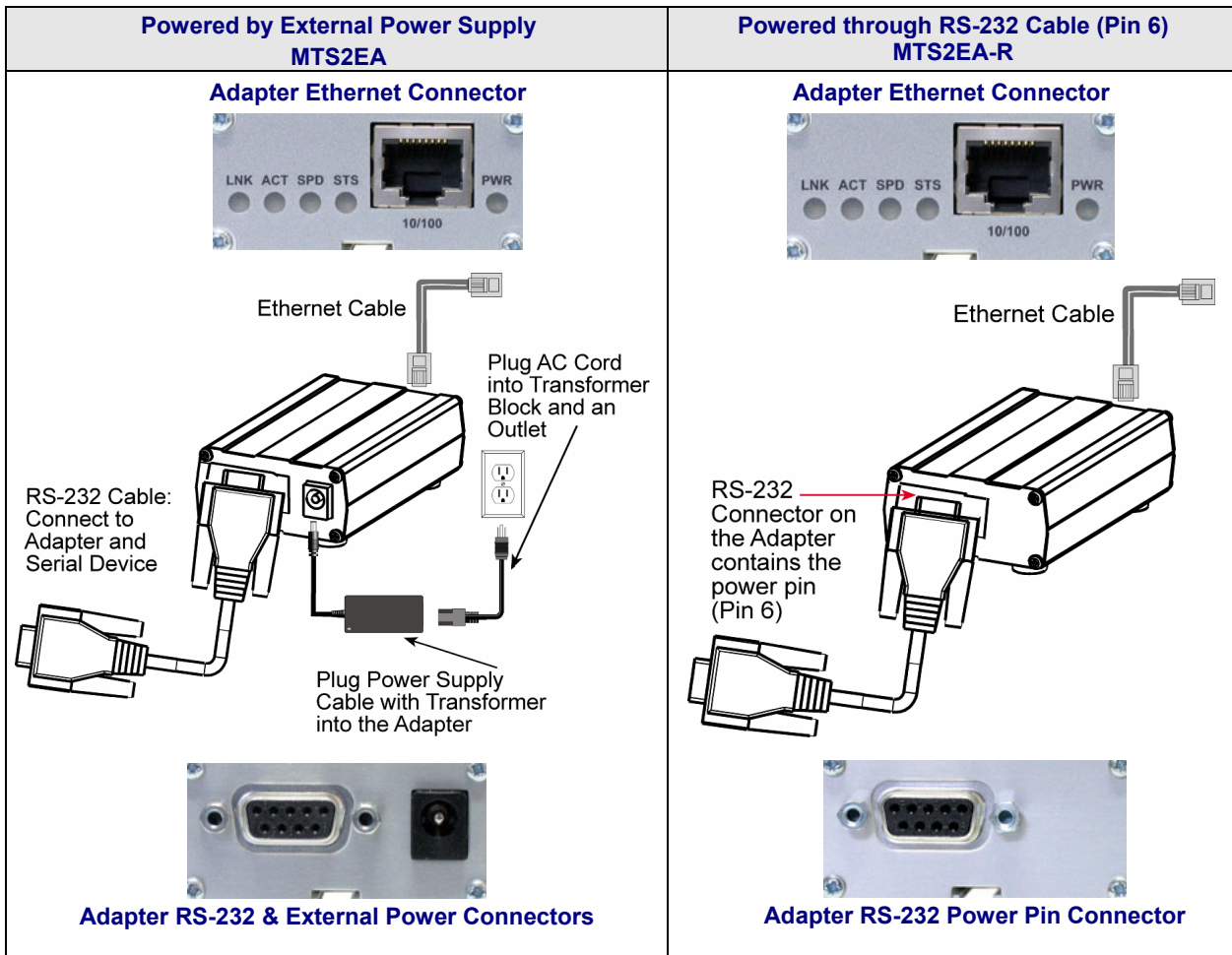

### Female End of the Multi-Tech Adapter

The following tables explain the Multi-Tech Adapter pin functions.

External Power		Multi-Tech Adapter Female Connector	Powered Through Pin 6	
Signal	IN/OUT		Signal	IN/OUT
Pin 1 CD	O		Pin 1 CD	O
Pin 2 TX	O		Pin 2 TX	O
Pin 3 RX	I		Pin 3 RX	I
Pin 4 DTR	I		Pin 4 DTR	I
Pin 5 GND	--		Pin 5 GND	--
Pin 6 DSR	O		Pin 6*	Power
Pin 7 CTS	I		Pin 7 CTS	I
Pin 8 RTS	O		Pin 8 RTS	O
Pin 9 RI	O		Pin 9 RI	O

*Pin 6 Input Power Consumption		
@ 5V DC:	Typical 190mA	Maximum 245mA
@ 10V DC:	Typical 100mA	Maximum 120mA
@ 15V DC:	Typical 69mA	Maximum 83mA
@ 20V DC:	Typical 54mA	Maximum 65mA
@ 25V DC:	Typical 45mA	Maximum 55mA

**Warning:**  
When supplying power to the RS-232 connector of the adapter, make sure the power does not feed the DTE device.

### Male End of the Multi-Tech Adapter

The following table explains the Multi-Tech Adapter pin functions.

RS-232		Multi-Tech Adapter Male Connector
Signal	IN/OUT	
Pin 1 CD	I	
Pin 2 RX	I	
Pin 3 TX	O	
Pin 4 DTR	O	
Pin 5 GND	-	
Pin 6 DSR	I	
Pin 7 RTS	O	
Pin 8 CTS	I	
Pin 9 RI	I	

# Chapter 3 – Managing and Configuring the MultiConnect Adapter

## Two Ways to Login

### Login Using Telnet Client

- Use Telnet Client to configure the MultiConnect Adapter for the first time. Type the default IP address of the Adapter: **192.168.2.1**.  
**Note:** The workstation must be on the same subnet.
- At the Login prompt, type `admin`.  
At the Password prompt, type `admin`.  
**Important:** User Name and Password are case-sensitive. They must be typed in lowercase letters.

### Login Using TTY

Use a terminal program, such as HyperTerminal, to access the serial port.

- Use TTY to configure your Adapter for the first time. Configure the workstation's serial port to the defaults listed below:  
Baud: 115.2K  
Data: 8  
Parity: N  
Stop: 1  
Flow-Control: None
- Press the Enter key three times to get to the Login prompt.
- At the Login prompt, type `admin`.  
At the Password prompt, type `admin`.  
**Important:** The User Name and Password are case-sensitive. They must be typed in lowercase letters.

## About Data Mode and Command Mode

- In **Command Mode**, a # sign designates the prompt. **Help**, at the command prompt, accesses a complete list of commands supported.
- **Usage**, at the command prompt, provides the semantics of the commands.
- In **Data Mode**, the # sign is not displayed.
- To end Command Mode, exit your terminal or Telnet session or invoke **Exit** at the command prompt.
- See the **Restore** command and **IP Escape String** command.

## Device Port

The RS-232 port.  
Connects to the Host/Serial interface on the device.  
Referred to as S0.

## **Chapter 4 – AT Commands**

See the separate Command Line Interface and Application Examples Reference Guide. The guide is included on Serial-to-Ethernet Adapter CD and on the Multi-Tech Web site.

# Chapter 5 – Auto-Discovery Manager

## Introduction

### *The Windows-Based Auto-Discovery Manager for the Serial-to-Ethernet Adapter*

The Auto-Discovery Manager is a mechanism for remotely monitoring the IPModule. It also provides support for configuring several key parameters, such as DHCP Status (enable/disable), IP Address, and the Hostname of a Serial-to-Ethernet Adapter.

The Auto-Discovery mechanism is utilized by running a Windows-based Server Application that can monitor/configure the Serial-to-Ethernet Adapter. Communication between the Serial-to-Ethernet Adapter and the Windows-based Server is through MAC level broadcasts on a configured UDP port.

### *Auto-Discovery Components*

The Auto-Discovery Manager is composed of two components:

- ***The Client Component*** – The Client component periodically broadcasts its current configuration over the network.
- ***The Server Component*** – The Server component receives the broadcasts from the client.

#### ***Client Component***

The Auto-Discovery Client component is integrated with Serial-to-Ethernet Adapter. It broadcasts its current configuration over the network on a specific UDP SERVER-PORT. By default the SERVER-PORT is set to 1020. The configuration parameters broadcast are

- Version details
- MAC Address
- Static IP Address
- DHCP Status
- DHCP Assigned IP Address
- Host Name
- Broadcast interval
- Port number on which the client listens

#### ***How to Disable the Client Auto-Discovery Broadcasts***

```
#set auto-discovery disable
```

**Note:** By default it is enabled

#### ***How to Change the Periodic Timer of Client's Broadcast***

```
#set auto-discovery broadcast-timer <t secs>
```

**Note:** By default it is 10 seconds.

#### ***How to Change the Server-Port***

```
#set auto-discovery server-port <port number>
```

## Server Component

The Server component listens on the SERVER-PORT. It receives the broadcasts from the client and updates the list of configuration parameters. This list can be viewed by the administrator through the User Interface:

The screenshot shows the 'IP Module Auto Discovery Manager' application window. At the top, there is a menu bar with 'File' and 'Help'. Below the menu bar is a header area with the MultiTech Systems logo and the title 'IP Module Auto Discovery Manager'. The main area contains a table with the following data:

S.No	MAC ADDRESS	IP ADDRESS	HOST NAME	DHCP STATUS	DHCP IP ADDRESS	CLIENT STATUS	F/W VERSI
1	00:C0:AD:34:56:CA	192.168.2.1	SocketEthernetIP	Enabled	192.168.7.5	Active	VER - 1.01
2	00:C0:7A:8B:4C:...	192.168.2.121	IPModule	Disabled	255.255.255.255	InActive	VER - 1.00

Below the table is a detailed view of a selected entry. The fields are:

- MAC ADDRESS: 00:C0:AD:34:56:CA
- IP ADDRESS: 192.168.2.1
- SUBNET MASK: 255.255.255.0
- DHCP IP ADDRESS: 192.168.7.5
- DHCP SUBNET MASK: 255.255.255.0
- DHCP STATUS:
- HOSTNAME: SocketEthernetIP
- CLIENT PORT NUMBER: 1020
- BROADCAST TIMER: 30
- F/W VERSION: VER - 1.01
- CLIENT ACTIVITY STATUS:

At the bottom of the window is a scrollable area for log files.

Annotations in the image:

- 'The List of Entries' points to the table.
- 'Detailed Information on about a Selected Entry' points to the detailed view fields.
- 'Log Files will display here' points to the log area at the bottom.

### How to View the Detailed Information

New entries are appended to the list shown on the screen above. Only the first ten entries are displayed on the screen. However the administrator can scroll down to view more entries. Clicking on an entry displays the detailed information about that entry.

### How to Edit the List and Make the Changes Permanent

1. Double-click on the entry you wish to edit.

**Continued: How to Edit the List and Make the Changes Permanent**

- After clicking the desired entry, a new dialog box displays showing the current configuration.

**Auto Discovery Manager - Edit Attributes**

Edit

MAC ADDRESS

IP ADDRESS

SUBNET MASK

DHCP STATUS

DHCP IP ADDRESS

DHCP SUBNET

HOSTNAME

CLIENT PORT

CLIENT ACTIVITY STATUS

BROADCAST TIMER

VERSION

- Enter the new parameters and click the **SET** button. The server sends the modified parameters to the client.

Upon receiving the broadcast from the Server, the Client validates the packet. The Client determines whether the packet is destined for its own MAC Address. If so, it sets the modified parameters that are different from its current configuration, and it broadcasts the newly configured parameters.

The Client Status is set to **Active** upon the receipt of a broadcast packet.

The Client Status is made **Inactive** if there is no request from the client for a stipulated period. (3 \* periodic timer value).

**How to Set the Parameters to the Previous Configuration**

When the **RESET** button is clicked, the parameters are set to the defaults received. In other words, **RESET** is similar to **UNDO** (it sets the modifications to the previous ones).

**Supported Feature – Saving the Log**

The logs can be saved to a file. They are spooled into the third part of the window in the main dialog box. To save the log:

Select **File > Save Log As** option to save the log.



# Chapter 6 – Upgrading the Firmware and Flash

## Upgrading the Firmware

### Prerequisites

#### 1. Serial Port Configuration

The default serial port parameters should be:

**Data length** – 8 bits

**Parity** – None

**Stop bits** – 1

**Baud-rate of the serial port** to which the Adapter is connected should be set to 115200 bps for proper operation.

#### 2. Enabling TFTP Server

Enable TFTP server on Adapter by issuing the following command:

```
# set ip tftp enable
OK
```

## Using Windows TFTP to Upgrade

#### 1. Open Command Prompt

Open the Windows **Command Prompt** program:

- Click the **Start** button in the lower left-hand corner of your screen.
- Click **Programs**.
- Click **Accessories**.
- Double-click **Command Prompt**.

#### 2. Enter the Upload Request

At the **C: prompt**, type:

```
tftp -i <ip-address> put <firmware-filename> AMD-tftp.bin
```

Then press **Enter**.

**Example:**

```
tftp -i 192.168.2.1 put c:\example.bin AMD-tftp.bin (Press Enter)
```

**Definitions of the Upload Request Parameters:**

- **<ip-address>**  
Address of the Serial-to-Ethernet Adapter to which you are uploading the firmware image.
- **<firmware filename>**  
Filename under which the firmware file was saved on your PC or local network.
- **AMD-tftp.bin <destination filename>**  
Filename must be AMD-tftp.bin. This is a case-sensitive file name; type it as shown here.

## Obtaining the Latest Firmware Version

To obtain the latest version of the firmware, contact your Multi-Tech Sales Representative or contact Multi-Tech directly by phone or email:

Phone: 763-785-3500 or 800-328-9717

Email: [oemsales@multitech.com](mailto:oemsales@multitech.com)

# Upgrading the Flash

## Serial Flash Upgrade

The following steps explain the procedure to upgrade a flash using the serial COM port (serial flash upgrade).

Connect the Adapter to a PC COM Port.

- Open an application through which we can access the serial device(e.g., Meterm, zoc, hyperterm).
- Reboot the Adapter.
- Wait for the boot message and prompt “press d to download” to appear.
- Press **d** when prompted.
- Select the **XMODEM** Protocol from the Terminal application.
- Choose a file (MTXCSEM-TFTP-...) file to be uploaded.
- Perform a file upload.



The Adapter reboots and will be up after a few seconds (10-15 secs).

## Ethernet Flash Upgrade

The Adapter can be remotely upgraded over a network. Make sure a TFTP client is already installed on the machine.

The following steps explain the method to perform flash upgrade from Ethernet.

- Make sure the Adapter is reachable on the LAN.
- Perform a TFTP to the Adapter from a TFTP client.
  - Set binary mode on (**Note:** This step is very important)
  - Binary
- Put the binary file.
  - put <binary filename>
- Exit the TFTP session.
  - quit

The Adapter reboots after it has been successfully upgraded.

# Appendix A – Regulatory Information

## Regulatory Information

### FCC Part 15 Regulation

This equipment has been tested and found to comply with the limits for a **Class A** digital device, pursuant to Part 15 of the FCC rules. These limits are designed to provide reasonable protection against harmful interference in a residential installation. This equipment generates, uses, and can radiate radio frequency energy, and if not installed and used in accordance with the instructions, may cause harmful interference to radio communications. However, there is no guarantee that interference will not occur in a particular installation. If this equipment does cause harmful interference to radio or television reception, which can be determined by turning the equipment off and on, the user is encouraged to try to correct the interference by one or more of the following measures:

Reorient or relocate the receiving antenna.

Increase the separation between the equipment and receiver.

Plug the equipment into an outlet on a circuit different from that to which the receiver is connected.

Consult the dealer or an experienced radio/TV technician for help.

This device complies with Part 15 of the FCC rules. Operation of this device is subject to the following conditions: (1) This device may not cause harmful interference, and (2) this device must accept any interference that may cause undesired operation.

**WARNING** – Changes or modifications to this unit not expressly approved by the party responsible for compliance could void the user's authority to operate the equipment.

### Industry Canada

This Class B digital apparatus meets all requirements of the Canadian Interference-Causing Equipment Regulations.

Cet appareil numérique de la classe B respecte toutes les exigences du Règlement Canadien sur le matériel brouilleur.



### EMC, Safety, and Directive Compliance

The CE mark is affixed to this product to confirm compliance with the following European Community Directives:

Council Directive 89/336/EEC of 3 May 1989 on the approximation of the laws of Member States relating to electromagnetic compatibility;

and

Council Directive 73/23/EEC of 19 February 1973 on the harmonization of the laws of Member States relating to electrical equipment designed for use within certain voltage limits.

# Appendix B – Warranty and Service

## **Multi-Tech Warranty Statement**

Multi-Tech Systems, Inc., (hereafter “MTS”) warrants that its products will be free from defects in material or workmanship for a period of two years from date of purchase, or if proof of purchase is not provided two years from date of shipment.

MTS MAKES NO OTHER WARRANTY, EXPRESS OR IMPLIED, AND ALL IMPLIED WARRANTIES OF MERCHANTABILITY AND FITNESS FOR A PARTICULAR PURPOSE ARE HEREBY DISCLAIMED.

This warranty does not apply to any products which have been damaged by lightning storms, water, or power surges or which have been neglected, altered, abused, used for a purpose other than the one for which they were manufactured, repaired by Customer or any party without MTS’s written authorization, or used in any manner inconsistent with MTS’s instructions.

MTS’s entire obligation under this warranty shall be limited (at MTS’s option) to repair or replacement of any products which prove to be defective within the warranty period or, at MTS’s option, issuance of a refund of the purchase price. Defective products must be returned by Customer to MTS’s factory — transportation prepaid.

MTS WILL NOT BE LIABLE FOR CONSEQUENTIAL DAMAGES, AND UNDER NO CIRCUMSTANCES WILL ITS LIABILITY EXCEED THE PRICE FOR DEFECTIVE PRODUCTS.

## **Repair Procedures for U.S. and Canadian Customers**

In the event that service is required, products may be shipped, freight prepaid, to our Mounds View, Minnesota factory:

Multi-Tech Systems, Inc.  
2205 Woodale Drive  
Mounds View, MN 55112  
Attn: Repairs, Serial # \_\_\_\_\_

A Returned Materials Authorization (RMA) is not required. Return shipping charges (surface) will be paid by MTS to destinations in U.S. and Canada.

Please include, inside the shipping box, a description of the problem, a return shipping address (must have street address, not P.O. Box), your telephone number, and if the product is out of warranty, a check or purchase order for repair charges.

For out of warranty repair charges, go to [www.multitech.com/DOCUMENTS/Company/warranty/](http://www.multitech.com/DOCUMENTS/Company/warranty/)

Extended two-year overnight replacement service agreements are available for selected products. Please call MTS customer service at (888) 288-5470 or visit our web site at [www.multitech.com/PARTNERS/Programs/orc/](http://www.multitech.com/PARTNERS/Programs/orc/) for details on rates and coverage’s.

Please direct your questions regarding technical matters, product configuration, verification that the product is defective, etc., to our Technical Support department at (800) 972-2439 or email [support@multitech.com](mailto:support@multitech.com). Please direct your questions regarding repair expediting, receiving, shipping, billing, etc., to our Repair Accounting department at (800) 328-9717 or (763) 717-5631, or email [mtsrepair@multitech.com](mailto:mtsrepair@multitech.com).

Repairs for damages caused by lightning storms, water, power surges, incorrect installation, physical abuse, or user-caused damages are billed on a time-plus-materials basis.

## **Repair Procedures for International Customers (Outside U.S.A. and Canada)**

Your original point of purchase Reseller may offer the quickest and most economical repair option for your Multi-Tech product. You may also contact any Multi-Tech sales office for information about the nearest distributor or other repair service for your Multi-Tech product. The Multi-Tech sales office directory is available at [www.multitech.com/PARTNERS/Channels/offices/](http://www.multitech.com/PARTNERS/Channels/offices/)

In the event that factory service is required, products may be shipped, freight prepaid to our Mounds View, Minnesota factory. Recommended international shipment methods are via Federal Express, UPS or DHL courier services, or by airmail parcel post; shipments made by any other method will be refused. A Returned Materials Authorization (RMA) is required for products shipped from outside the U.S.A. and Canada. Please contact us for return authorization and shipping instructions on any International shipments to the U.S.A. Please include, inside the shipping box, a description of the problem, a return shipping address (must have street address, not P.O. Box), your telephone number, and if the product is out of warranty, a check drawn on a U.S. bank or your company’s purchase order for repair charges. Repaired units shall be shipped freight collect, unless other arrangements are made in advance.

Please direct your questions regarding technical matters, product configuration, verification that the product is defective, etc., to our Technical Support department nearest you or email [support@multitech.com](mailto:support@multitech.com). When calling the U.S., please direct your questions regarding repair expediting, receiving, shipping, billing, etc., to our Repair Accounting department at +(763) 717-5631 in the U.S.A., or email [mtsrepair@multitech.com](mailto:mtsrepair@multitech.com).

Repairs for damages caused by lightning storms, water, power surges, incorrect installation, physical abuse, or user-caused damages are billed on a time-plus-materials basis.

## ***Repair Procedures for International Distributors***

International distributors should contact their MTS International sales representative for information about the repairs for their Multi-Tech product.

Please direct your questions regarding technical matters, product configuration, verification that the product is defective, etc., to our International Technical Support department at +(763)717-5863. When calling the U.S., please direct your questions regarding repair expediting, receiving, shipping, billing, etc., to our Repair Accounting department at +(763) 717-5631 in the U.S.A. or email [mtsrepair@multitech.com](mailto:mtsrepair@multitech.com).

Repairs for damages caused by lightning storms, water, power surges, incorrect installation, physical abuse, or user-caused damages are billed on a time-plus-materials basis.

## ***Replacement Parts***

SupplyNet, Inc., can supply you with replacement power supplies, cables and connectors for selected Multi-Tech products. You can place an order with SupplyNet via mail, phone, fax or the Internet at the following addresses:

Mail:                   SupplyNet, Inc.  
                          614 Corporate Way  
                          Valley Cottage, NY 10989

Phone:                800 826-0279

Fax:                    914 267-2420

Email:                [info@thesupplynet.com](mailto:info@thesupplynet.com)

Internet:            <http://www.thesupplynet.com>

# Index

<b>A</b>	
Applications.....	4
AT Commands.....	13
Auto-Discovery Manager .....	14
<b>C</b>	
Command Mode .....	12
Connecting the Power.....	10
<b>D</b>	
Data Mode .....	12
<b>E</b>	
EMC, Safety, and Directive Compliance.....	19
Ending Command Mode.....	12
<b>F</b>	
FCC Part 15 Regulation .....	19
Firmware upgrading.....	17
Flash Upgrade - Ethernet .....	18
Flash Upgrade - Serial .....	18
Functional Features.....	8
<b>H</b>	
Handling Precautions.....	5
<b>I</b>	
Installation .....	9
Internet Applications.....	7
Internet-Enable Any Device .....	4
<b>L</b>	
LED Indicators .....	8
Login Using Telnet Client.....	12
Login Using TTY.....	12
<b>O</b>	
Ordering Replacement Parts.....	21
<b>P</b>	
Package Contents .....	5
Pin Functions.....	11
<b>R</b>	
Reduced Development Time .....	4
Repairs and Service.....	20
Replacement Parts .....	21
<b>S</b>	
Setup Example .....	10
Software Features.....	7
Specifications .....	6
<b>T</b>	
TTY login.....	12
<b>U</b>	
Upgrading firmware .....	17
<b>W</b>	
Warranty.....	20