

# *Smartio* C168H/PCI User's Manual

Smartio 8 Ports Serial Board for PCI Bus

Jul. 1999 (2nd Edition)

The content of this manual is also available in CD-ROM and at Moxa Web Site.



Moxa Technologies Co., Ltd.

Tel: +866-2-8665-6373

Fax: +886-2-8665-6372

[www.moxa.com](http://www.moxa.com)

[support@moxa.com.tw](mailto:support@moxa.com.tw)

# *Smartio* C168H/PCI User's Manual

The software described in this manual is furnished under a license agreement and may be used only in accordance with the terms of the agreements.

## **Copyright Notice**

Copyright © 1999 Moxa Technologies Co., Ltd.

All rights reserved.

Reproduction in any form without permission is prohibited.

## **Trademarks**

MOXA is a registered trademark of Moxa Technologies Co., Ltd.

All other trademarks or registered marks in this manual belong to their respective manufacturers.

## **Disclaimer**

Information in this document is subject to change without notice and does not represent a commitment on the part of Moxa.

Moxa provides this document "as is", without warranty of any kind, either expressed or implied, including, but not limited to, the particular purpose. Moxa may make improvements and/or changes in this manual or in the product(s) and/or the program(s) described in this manual at any time.

Information provided in this manual is intended to be accurate and reliable. However, Moxa Technologies assumes no responsibility for its use, or for any infringements of rights of the fourth parties which may result from its use.

This product could include technical or typographical errors. Changes are periodically made to the information herein; these changes may be incorporated in new editions of the publication.

# MOXA Internet Services

Customer's satisfaction is always our number one concern. To ensure that customers get the full benefit of our services, Moxa Internet Services have been built for technical support, product inquiry, new driver update, user's manual update, etc.

The followings are the services we provide.

E-mail for technical support

address: [support@moxa.com.tw](mailto:support@moxa.com.tw)

FTP site for free driver update

address: [ftp.moxa.com](ftp:moxa.com)

or

[ftp.moxa.com.tw](ftp:moxa.com.tw)

user ID: *ftp*

password: *your\_email\_address*

World Wide Web (WWW) Site for product info

address: [www.moxa.com](http://www.moxa.com)

or [www.moxa.com.tw](http://www.moxa.com.tw)

# About This Manual

This manual is composed of six Chapters and one Appendix. This manual is written for installer, system administrator and software programmer.

If you are a first-time installer and system administrator, we recommend you to go through the whole manual except Chapter 4 “**Serial Programming Tools**”.

If you are a software programmer, you may refer to Chapter 4 “**Serial Programming Tools**”.

If you need cable wiring information, please see Chapter 5 “**Connection Option (Opt8x) and Cable Wiring**”.

If you encounter any problem during installation, please refer to Chapter 6 “**Troubleshooting**”.

## **Chapter 1 Introduction**

This chapter gives the overview and features for C168H/PCI. Check-list and overall installation guide are also included.

## **Chapter 2 Hardware Installation**

This chapter gives details of how to do hardware installation for C168H/PCI and connection option (Opt8x).

## **Chapter 3 Software Installation**

This Chapter describes the software installation, board and ports configuration, driver update and removal for various operating systems: Windows NT, and Windows 95/98.

## **Chapter 4 Serial Programming Tools**

This Chapter roughly describes the programming tools for various O.S. platforms, including *PComm Lite* under Windows NT and Windows 95/98. Also, RS-485 programming issue is discussed (for Opt8J).

## **Chapter 5 Connection Option (Opt8x) and Cable Wiring**

This Chapter describes the RS-232/422/485 cable wiring for each connection option (Opt8x).

## **Chapter 6 Troubleshooting**

This Chapter describes error might happen and possible solutions for C168H/PCI.

## **Appendix Technical Reference**

This chapter describes specification, PCI, UART, and DB62 pinouts.

# Table of Contents

<b>Introduction .....</b>	<b>1-1</b>
Overview-----	1-1
Features-----	1-2
Check List-----	1-3
Installation Guide-----	1-5
<b>Hardware Installation .....</b>	<b>2-1</b>
Installing the Smartio C168H/PCI Board-----	2-1
Installing Connection Option Opt8x-----	2-2
<b>Software Installation.....</b>	<b>3-1</b>
Windows NT-----	3-1
Installing Driver-----	3-2
Configuring Board and Port-----	3-8
Updating Driver-----	3-11
Removing Driver-----	3-12
Windows 95/98-----	3-13
Installing Driver-----	3-13
Configuring Board and Port-----	3-21
Updating Driver-----	3-23
Removing driver-----	3-25
<b>Serial Programming Tools.....</b>	<b>4-1</b>
<i>PComm</i> Installation-----	4-1
<i>PComm</i> Programming Library-----	4-2
Utility-----	4-2
RS-485 Programming for Opt8J-----	4-6
<b>Connection Option (Opt8x) &amp; Cable Wiring .....</b>	<b>5-1</b>
RS-232 Cable Wiring for Opt8A/B/C/D/S-----	5-1
RS-422 Cable Wiring for Opt8J/F/Z-----	5-8
RS-485 Cable Wiring for Opt8J-----	5-10
RS-422/485 Impedance Matching-----	5-11
<b>Troubleshooting .....</b>	<b>6-1</b>
General Troubleshooting-----	6-1
Windows NT-----	6-2
Windows 95/98-----	6-3

<b>Technical Reference.....</b>	<b>A-1</b>
Specification .....	A-1
PCI .....	A-1
UART 16C550C.....	A-2
DB62 Connector Pinouts .....	A-3

# 1

## Introduction

### Overview

#### *Smartio* - The Smart Multiport Async Solutions

The term *Smartio* represents smart multiport serial I/O solution. *Smartio C168H/PCI* is designed for 32-bit PCI bus with Plug and Play feature. It offers 8 serial ports for connecting terminals, modems, printers, data acquisition equipment and any other serial devices to the PC and its compatible systems. Being a well-designed and fine-tuned device driver, the *Smartio* board makes full use of the 32 byte Tx/Rx FIFO and on-chip H/W flow control, which makes it possible transferring data without loss at high speed as 921.6 Kbps. They offer a reliable and high performance solution for serial multiport communications.

#### Board Applications

The board applies for many applications. Here are a few:

- 1 Internet/Intranet Connection
- 1 Remote Access Application
- 1 Multi-user Application
- 1 Industrial Automation
- 1 Office Automation
- 1 Telecommunication
- 1 PC-based (vending) Machine or Kiosk System

---

## 1 Point-of-Sale (POS) System

### PCI Solution

The board complies with PCI Spec. 2.1 needing neither switch nor jumper. The hardware configuration for the IRQ and Memory addresses is automatically assigned by the PCI BIOS. Hence, the board **MUST** be plugged first before installing the software driver. For more PCI information, please refer to Appendix “**Technical Reference**”.

### Operating System Support

It supports Windows NT, Windows 95/98 and DOS with user-friendly installation, configuration and performance.

### MOXA Serial Comm Tool

For application development, MOXA provides an easy-to-use serial communication library (*PCComm*) under Windows NT and Windows 95/98. With the library, it is easy to develop your own applications using sample applications developed with Visual Basic, Visual C++, Borland Delphi, etc. Utilities, such as diagnostic, monitor, terminal emulation, etc., are also included for debugging or monitoring the communication status or terminal emulation, or even file transferring.

## Features

- ✓ Compact board size, half-size
- ✓ Plug and play, no switch no jumper
- ✓ Surge/isolation protection option
- ✓ High speed 16C550C Communication Controller with on-chip hardware flow control, no data loss
- ✓ Windows NT/95/98 device drivers and *PCComm* serial comm tool
- ✓ Bus interface: 32-bit PCI
- ✓ Number of ports: 8
- ✓ I/O address: Assigned by PCI BIOS
- ✓ IRQ: Assigned by PCI BIOS
- ✓ Data bits: 5, 6, 7, 8
- ✓ Stop bits: 1, 1.5, 2
- ✓ Parity: None, even, odd, space, mark
- ✓ UART: 8»ë16C550C or compatible



- ✓ Speed (bps): 50 ~ 921.6K
- ✓ Connectors: 8×DB25/DB9, male or female
- ✓ Data signals: RS232×TxD, RxD, RTS, CTS, DTR, DSR, DCD, GND  
RS422×TxD+(B), TxD-(A), RxD+(B), RxD-(A), GND  
(Opt8J:RTS+(B), RTS-(A), CTS+(B), CTS-(A))  
RS485×Data+(B), Data-(A), GND
- ✓ Operating temp: 0 ~ 55 °C
- ✓ Power requirement: 180mA max. (+5V), 110mA max. (+12V), 160mA max. (-12V)
- ✓ Dimensions: 123 mm×100 mm
- ✓ Popular O.S. Support:

	C168H/PCI
Windows NT	✓
Windows 95/98	✓
Dos	R

- ✓ : Driver supported by Moxa and shipped with product
- R : Driver supported by Moxa and shipped by request
- Note: You can download the latest versions of drivers for above O.S. from the MOXA FTP service. For other O.S. drivers (other than O.S. listed above), please check out MOXA web site to see whether they are available.

## Check List

Upon unpacking the *Smartio* C168H/PCI, you should find the following items in the package,

- ✓ *Smartio* C168H/PCI 8 port serial board
- ✓ Device driver diskettes:
  - 1 **Windows NT** and **Windows 95/98** ×1
  - 1 **PCComm Lite** ×1
- ✓ *Smartio* C168H/PCI User's Manual (This manual)
- ✓ One of the following connection options:

### Opt8A/Opt8B/Opt8S

- ✓ RS-232 connection box with 8 DB25 female/male ports (surge protection for Opt8S).
- ✓ 1.5 meter DB62 to DB62 cable.

---

### **Opt8C/Opt8D**

- ✓ RS-232 octopus cable with 8 port male connectors, DB25 for Opt8C or DB9 for Opt8D (1 meter long).

### **Opt8F/Opt8Z**

- ✓ RS-422 connection box with 8 port female DB25 connectors (isolation protection for Opt8F).
- ✓ 1.5 meter DB62 to DB62 cable.
- ✓ 110V or 220V adapter included.

### **Opt8J**

- ✓ RS-422/485 connection box with 8 port female DB25 connectors.
- ✓ 1.5 meter DB62 to DB62 cable.
- ✓ 110V or 220V adapter included.

## Installation Guide

This section gives a brief summary of how to install the *Smartio* C168H/PCI under each supported operating system. Installation is simple and involves the following stages:

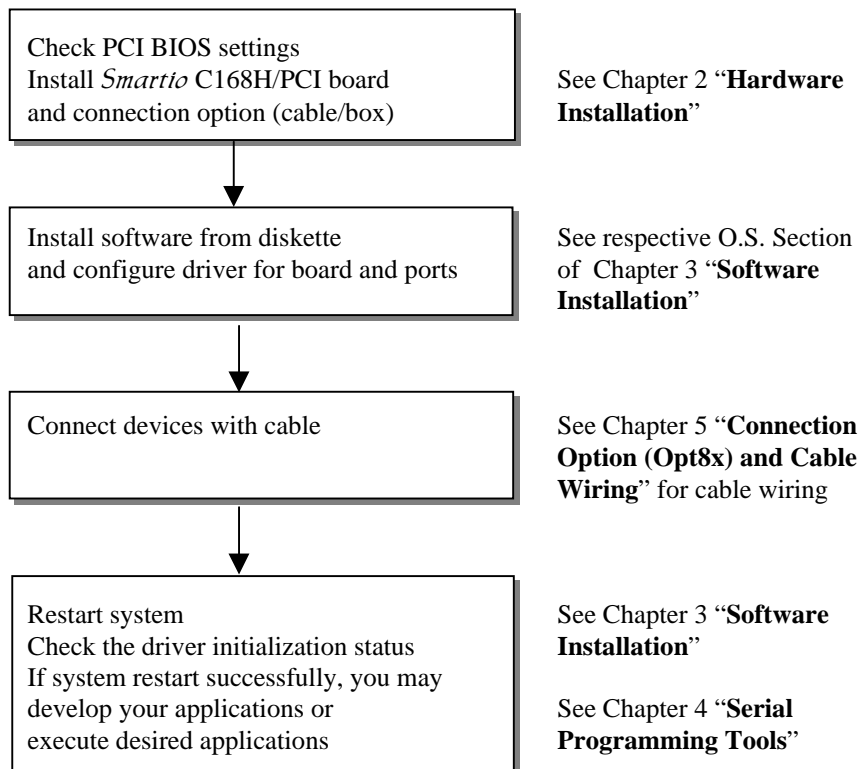



# 2

## Hardware Installation

The installation of the *Smartio* C168H/PCI consists of hardware and software installation. The respective sections of the operating systems in the next chapter will discuss more about the software installation. The hardware installation is described in this chapter.

The no-switch-no-jumper *Smartio* C168H/PCI board hardware configuration for IRQ number and I/O addresses is automatically assigned by the PCI BIOS. Hence, the board **MUST** be plugged first before installing the software driver.

### Installing the Smartio C168H/PCI Board

**Step 1:** Power off the PC.

<p><b>Warning!</b> Make sure your system is switched off before you start installing any board. If you don't, you may risk damaging your system and the board.</p>
--

**Step 2:** Remove the PC cover.

**Step 3:** Remove the slot cover bracket if there is any.

**Step 4:** Plug the *Smartio* C168H/PCI(s) in the free PCI expansion slot(s) of the PC.

**Step 5:** Fasten the holding screw to fix the control board in place.

**Step 6:** Replace the system cover.

---

**Step 7:** Connect one of the connection box/cable (also adapter if required) detailed in the next section.

**Step 8:** Power on PC and BIOS will automatically set the IRQ and memory address.

**Note !**

**Each board must occupy one unique IRQ and one unique memory address, which are assigned by PCI BIOS automatically.** However, you may select the free IRQ number manually via PC's BIOS setup for PCI slot, but normally this method is not available for memory. The possible IRQ numbers are 2, 3, 4, 5, 9, 10, 11, 12, and 15. The possible I/O addresses are from 0x0000 to 0xFFFF.

**Step 9:** Proceed with software installation detailed in the next Chapter “**Software Installation**”.

## Installing Connection Option Opt8x

Connect the *Smartio* C168H/PCI with the one of the following connection options. Then you can connect your modem, serial printer, PC COM1/2, bar code reader, POS, instrument or any other serial devices to the DB25/DB9 connectors. Refer to Chapter “**Connection Option (Opt8x) and Cable Wiring**” for RS-232/RS-422/RS-485 cable wiring.

### Opt8A/Opt8B/Opt8S

Hold one end of the DB62 cable and plug it into the DB62 connector on the bracket of the *Smartio* C168H/PCI. Carefully screw it until it is tight. Then plug the other end of the cable to the RS-232 connection box's DB62 connector. Both ends of the cable are identical.

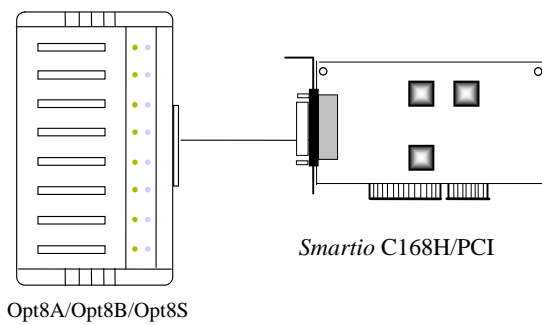

### Opt8C/Opt8D

Hold one end of the DB62 cable and plug it into the DB62 connector on the bracket of the *Smartio* C168H/PCI. Screw it carefully until it fits.

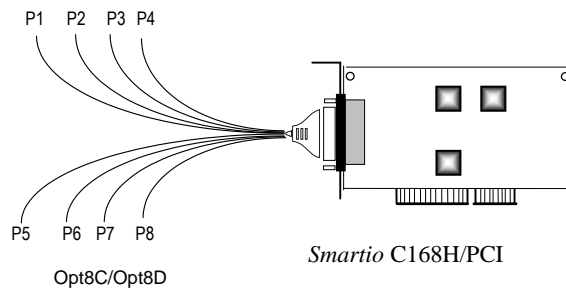

---

## Opt8J/Opt8F/Opt8Z

Hold one end of the DB62 cable and plug it into the DB62 connector on the bracket of the *Smartio* C168H/PCI. Carefully screw it until it is tight. Then plug the other end of the cable to the RS-422/RS-485 connection box's DB62 connector. Both ends of the cable are identical. After that, don't forget to apply power via the adapter to the Opt8J/F/Z.

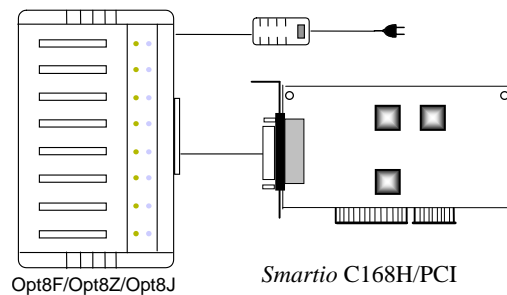

Refer to Chapter “**Connection Option (Opt8x) and Cable Wiring**” for RS-232/RS-422/RS-485 cable wiring. And also to Chapter “**Serial Programming Tools**” for RS-232/RS-422/RS-485 programming details.

## Operating Opt8J

**Opt8J** is the RS-422/485 connection box with 8 port female DB25 connectors for MOXA 8 port boards, including the *Smartio* C168H/PCI. There are 8-DIP switches on the side of the Opt8J. Each switch controls the communication mode (RS-422 or RS-485) of each port respectively.



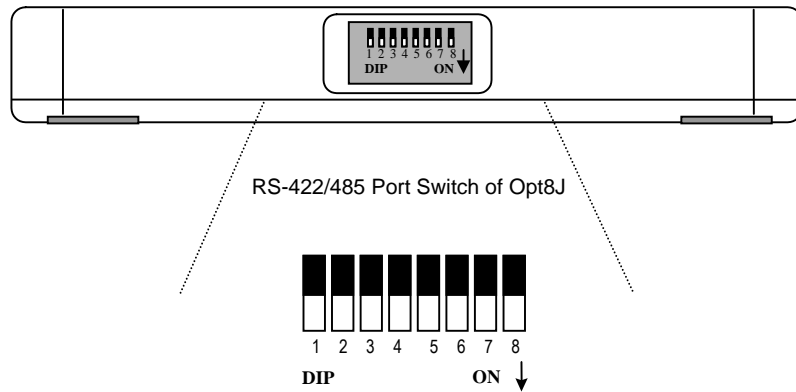

**RS-422 Mode**

Set the respective switch to **OFF** position to use RS-422 interface. This means the port is always ready to transmit and receive data simultaneously (full-duplex).

**RS-485 Mode**

The Opt8J supports only 2-wire RS-485 communication. Set the respective switch to **ON** position to use RS-485 interface. This means the port can transmit data only when RTS is asserted, and receive data only when RTS is not asserted (half-duplex).

Refer to Chapter “**Connection Option (Opt8x) and Cable Wiring**” for RS-422/RS-485 cable wiring, and also to Chapter “**Serial Programming Tools**” for Opt8J RS-485 programming details.



# 3

## Software Installation

In this chapter, the software driver installation, configuration and driver update/removal procedures are described for various operating systems, including Windows NT, and Windows 95/98. Before proceeding with the software installation, complete the hardware installation first.

If it is required to develop your own applications, please refer to the next chapter, “**Serial Programming Tools**” for serial programming issues.

### Windows NT

Windows NT supports up to **256** serial ports, from **COM1** to **COM256**. To fully utilize the advanced features of Windows NT, multi-process, multi-thread, and pure 32-bit Windows NT device drivers are developed for the *Smartio* C168H/PCI and other MOXA multiport boards. The drivers conform to Win32 COMM API standard.

To install the driver for the very first time, please go directly to Section “**Installing Driver**”.

To re-configure the board and port for installed boards, please refer to Section “**Configuring Board and Port**”.

To update the driver for installed boards, please refer to Section “**Updating Driver**”.

To remove the driver, please go to Section “**Removing Driver**”.

---

## Installing Driver

### First Time Installing Driver

Following is the procedures for installing the *Smartio* C168H/PCI driver for the first time under Windows NT 3.51/4.0. Make sure the board (s) has (have) already been plugged in the system PCI slot (s).

1. Please log in NT as Administrator.
2. Open [Control Panel], click [Network] icon and select [Adapters] tab.
3. Click [Add] button, then [Have Disk...] button in [Select Network Adapter] dialog box.
4. Specify the exact path of the driver diskette, A:\WINDOWS.NT. Then click [OK] button.

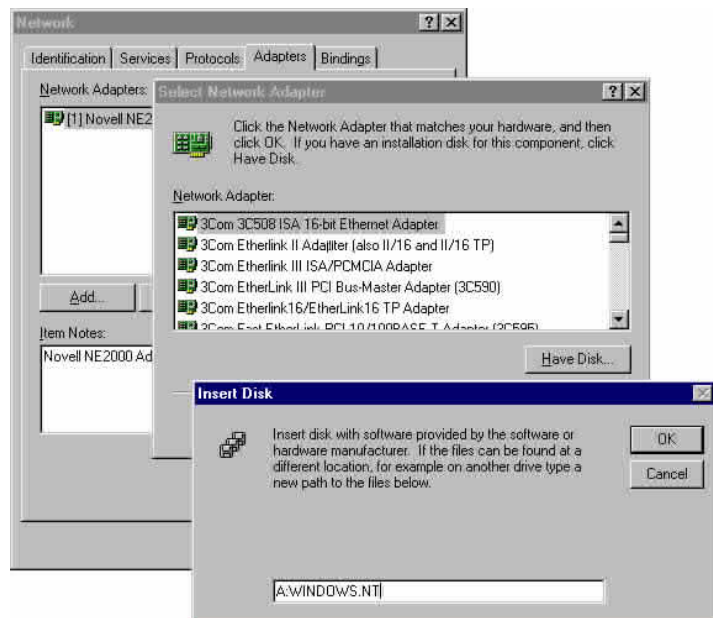

5. Select **MOXA Smartio/Industio Family multiport board** in **Select OEM Option** dialog box, and click **[OK]** to start driver installation.

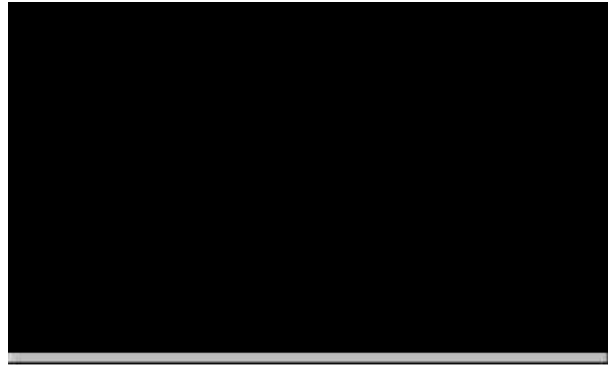

**Moxa Smartio/Industio Configuration Panel** dialog box appears.

6. Click **[Add]** button to open **Property** dialog box to change port setting and advanced FIFO configuration done automatically by the system.

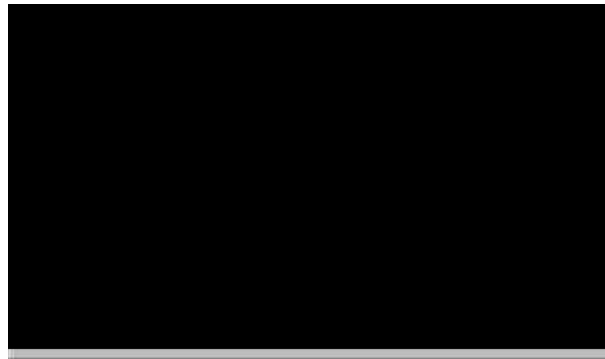

7. Select the newly plugged C168H/PCI board from the **Board Type** pull-down list.
8. Click on a specific port Item.
9. Click **[Port Setting]** button to open **Port X** dialog box.

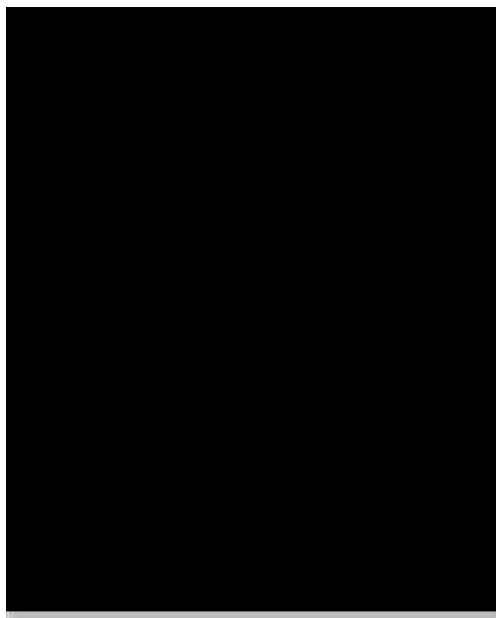

10. Select a COM number for the specific port from **Port Number** pull-down list.

**Note!** Step 11 is optional, if you want to assign COM numbers to ports manually.

11. Check **Auto Enumerating COM Number** check-box then the subsequent ports are mapped to continuous COM numbers. For example, if COM 3 is assigned to Port 1, then COM 4 will be automatically assigned to Port 2.

**Note!** You may skip Step 12 to 15, if the system doesn't require a special performance tuning.

12. Select an Rx FIFO Trigger from **Rx FIFO Trigger** pull-down list.

Rx FIFO trigger levels, at 1, 4, 8 or 14 bytes, are available, and the default value is 14 bytes.

13. Check **Set the change to all ports** check-box then if desire to apply Rx FIFO Trigger just defined to all ports.
14. Select a Tx FIFO Size from **Tx FIFO Size** pull-down list.

Tx FIFO sizes from 1 to 16 bytes are available, and the default value is 16 bytes.

15. Check **Set the change to all ports** check-box then the if desire to apply Tx FIFO Size just defined to all ports.

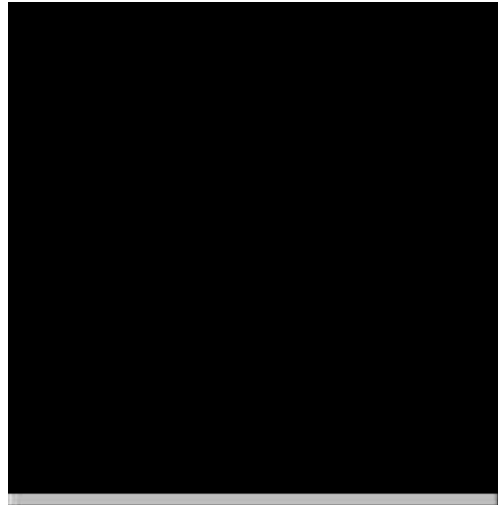

16. Click [**OK**] button in **Port X** dialog box to confirm the port setting.
17. Click [**OK**] button in **Property** dialog box to complete the port setting and return to **Moxa Smartio/Industio Configuration Panel** dialog box.

Now the configured C168H/PCI board item will be shown in **Moxa Smartio/Industio Configuration Panel** dialog box.

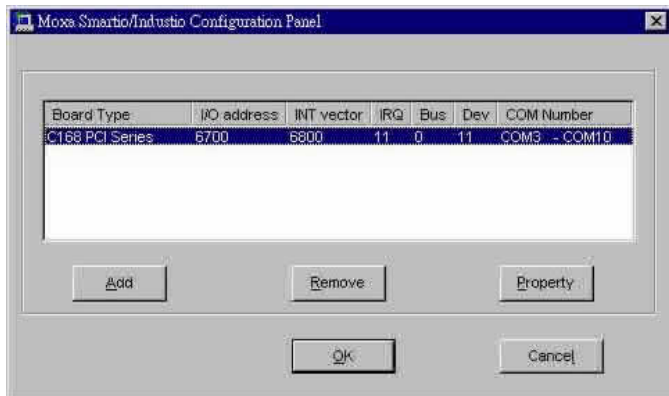

18. Click [OK] button in **Moxa Smartio/Industio Configuration Panel** to return to Network dialog box.
19. Click [OK] button in to exit **Network** dialog box.
20. Restart the PC.

**Note!** The driver configuration will NOT take effect until you restart the PC.

**Note!** Double check if all the *Smartio* C168H/PCI components – the control board and one of the connection options – are connected and fastened tightly to make sure that the system and the driver start successfully.

Once the system restarts, you may check the event log issued by the MOXA driver to see if the ports of the board are initialized successfully.

21. Enter the [Administrative] group, click [Event Viewer] icon and select [Log] and [System] to check a message similar to “**MOXA C168PCI series, with first serial port COM3, has been enabled**” for each configured board.



**Note!**

If an error message similar to “**Cannot find any configured MOXA Smartio/Industio series board!**” pops up, refer to the Troubleshooting chapter for solutions.

Once the board and the driver are installed and the driver restarts successfully, you can start to develop applications with the *PComm* library (See “**Serial Programming Tools**”) or the Microsoft Win32 API. You can also execute any ready-made applications, such as *PComm* utility Terminal emulator (See “**Serial Programming Tools**”) or HyperTerminal to transmit/receive data, as well as Remote Access Service to provide dial-up networking capabilities.

---

## Configuring Board and Port

### Re-configure Port Setting

If the driver is installed and only desire to re-configure the ports, please refer to the following procedures. Except procedures listed below, it is also allowed to do so by clicking [Start] è [Program Files] è [MOXA Utility] è [Moxa Smartio/Industio Configuration Panel] è [Property] and then refer to Step 6-21 in the previous section “First Time Installing Driver” of “Windows NT” section.

1. Open [Control Panel], click [Network] icon and select [Adapters] tab.
2. Click on **MOXA Smartio/Industio Family Adapter** in **Network Adapters** list
3. Click [Properties] button to open **Moxa Smartio/Industio Configuration Panel** dialog box to change port setting and advanced FIFO configuration.

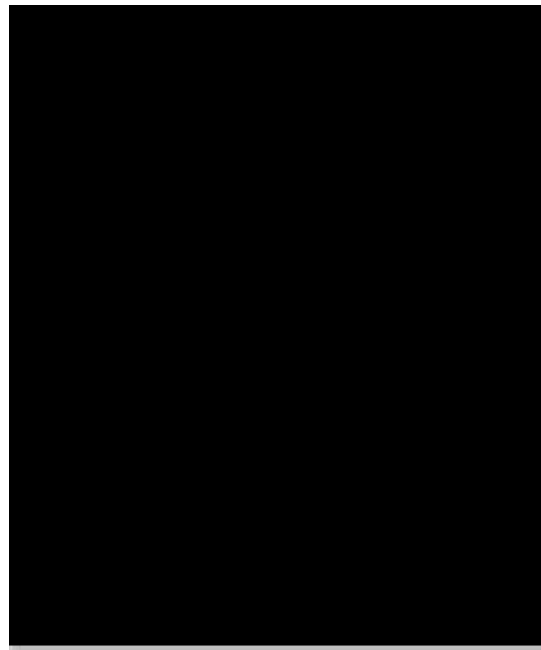

4. Click [**Property**] button in **Moxa Smartio/Industio Configuration Panel** dialog box to open **Property** dialog box.

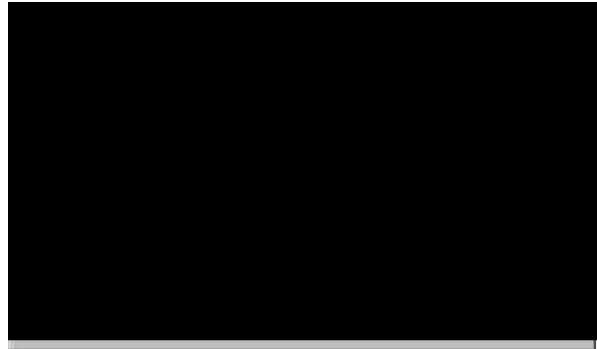

5. Then please refer to Step 6 to 21 in “**First Time Installing Driver**” of “**Windows NT**” section.

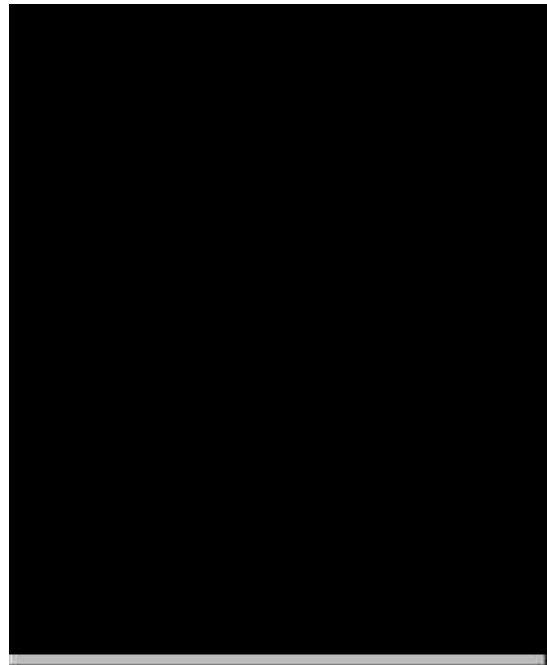

---

## Add Another C168H/PCI Board Configuration

If another MOXA C168H/PCI board is plugged and needed to be configured, please see this section for details. Up to four C168H/PCI board can be installed in ONE system under Windows NT as long as the system sources is sufficient.

Except procedures listed below, it is also allowed to do so by clicking [**Start**] è [**Program Files**] è [**MOXA Utility**] è [**Moxa Smartio/Industio Configuration Panel**] and then also refer to step 6-21 in the previous section “**First Time Installing Driver**” of “**Windows NT**” section.

1. Open [**Control Panel**], click [**Network**] icon and select [**Adapters**] tab.
2. Click on **MOXA Smartio/Industio Family Adapter** in **Network Adapters** list.
3. Click [**Properties**] button to open **Moxa Smartio/Industio Configuration Panel** dialog box.

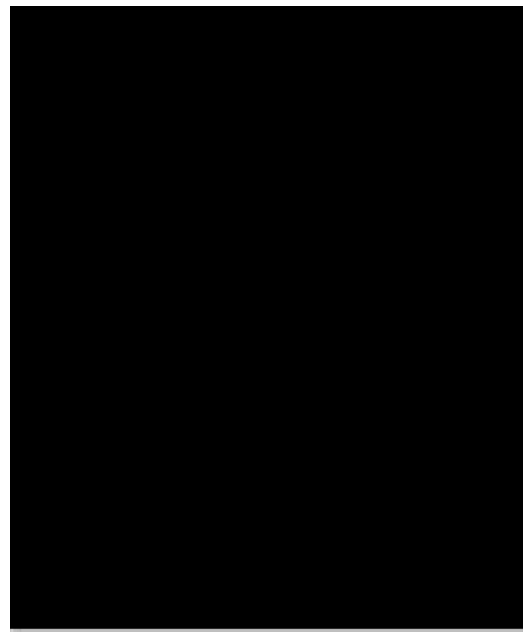

4. Then please refer to Step 6 to 21 in “**First Time Installing Driver**” of “**Windows NT**” section.

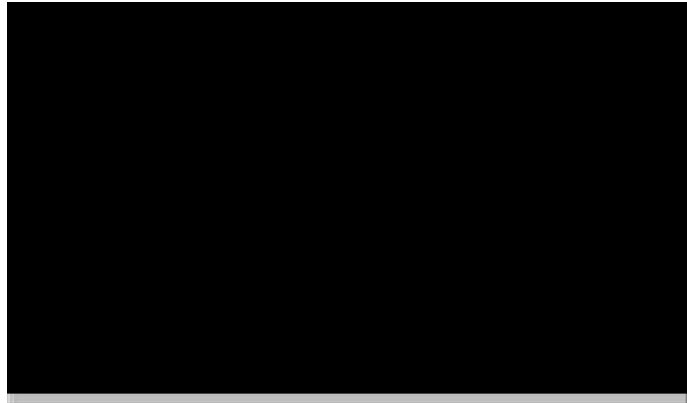

### **Remove Existing C168H/PCI Board Configuration**

By unplugging C168H/PCI board, the system will automatically remove the configuration. Therefore, there is no need to do removal action from **Moxa Smartio/Industio Configuration Panel** dialog box.

### **Updating Driver**

To update the driver for the *Smartio* C168H/PCI board, simply follow the following procedures.

1. Open [**Control Panel**], click [**Network**] icon, and select [**Adapters**] tab.
2. Click on **MOXA Smartio/Industio Family Adapter** in the **Network Adapter** list.
3. Click [**Remove**] button in **Network** dialog box.
4. Click [**Close**] button in **Network** dialog box.
5. Restart the system.

- 
6. Please refer to Step 1 to 21 in “**First Time Installing Driver**” of “**Windows NT**” section to install the new driver.

## Removing Driver

To remove the driver for the *Smartio* C168H/PCI board,

1. Open [**Control Panel**], click [**Network**] icon, and select [**Adapters**] tab.
2. Click on **MOXA Smartio/Industio Family Adapter** in the **Network Adapter** list.
3. Click [**Remove**] button in **Network** dialog box.



4. Click [**Close**] button to exit **Network** dialog box.
5. Restart the system to activate the new configuration.

## Windows 95/98

Windows 95/98 driver supports up to **128** serial ports, from **COM1** to **COM128**. To fully utilize the advanced features of Windows 95/98, multi-process, multi-thread and pure 32-bit Windows 95/98 virtual device port drivers (VxD) compliant with communication drivers (VCOMM) are developed for the *Smartio* C168H/PCI and other MOXA multiport boards. The drivers conform to the Win32 COMM API standard.

To install the driver for the first time, or to add more boards, please go directly to Section “**Installing Driver**”.

To re-configure the ports for installed boards, please refer to Section “**Configuring Board and Port**”.

To update the driver, please go to Section “**Updating Driver**”.

To remove the driver, please go to Section “**Removing Driver**”.

## Installing Driver

You can easily plug the *Smartio* C168H/PCI board and work right away with very little installation efforts under Windows 95/98 supporting **Plug and Play** capability. Windows 95/98 will automatically detect the presence of the newly plugged board and prompt you to install the software driver for the first time. In this case, you need the driver diskette.

At most 4 *Smartio* C168H/PCI boards can be installed in ONE system as long as the I/O addresses and IRQ number resources are sufficient and available in the system.

The following flow chart illustrates the driver installation stages of the *Smartio* C168H/PCI boards. Each stage will be discussed later.

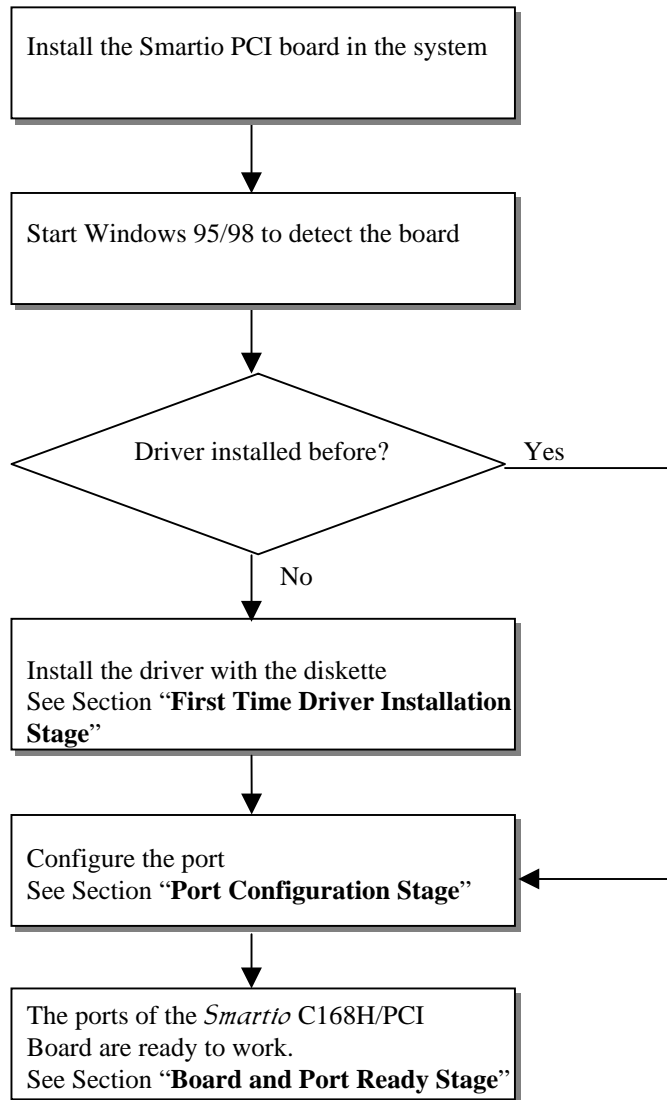



## First Time Driver Installation Stage

This stage presents the steps for installing the driver for the first time of the first *Smartio* C168H/PCI board. The installation of the *Smartio* C168H/PCI board for Windows 95 and Windows 98 are slightly different and will be described in two columns. Follow the steps in the left column for Windows 95 or the right column for Windows 98 respectively.

If one MOXA C168H/PCI board had been previously installed and another MOXA C168H/PCI board was plugged, the system will prompt you to do **Port Configuration Stage** discussed in the next section and skips this stage.

1. Upon detecting **the first new *Smartio* C168H/PCI board**, Windows 95/98 will automatically display a **New hardware found** message box, and then pop up the following dialog boxes. Click **Next** button.

Windows 95



2. Click [**Other Locations**] button.

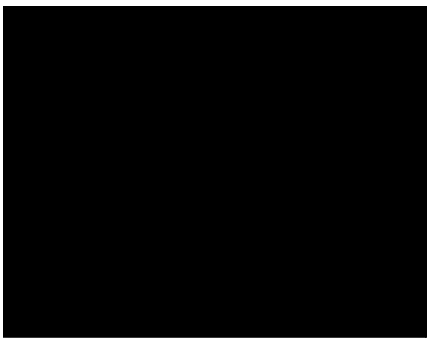

Windows 98



2. Select [**Display a list...**] and click **Next** button.



- 
3. Type A:\Windows.95 in the Location field, and click **[OK]** button in **Select Other Location** dialog box. The system will start reading the files from the diskette.

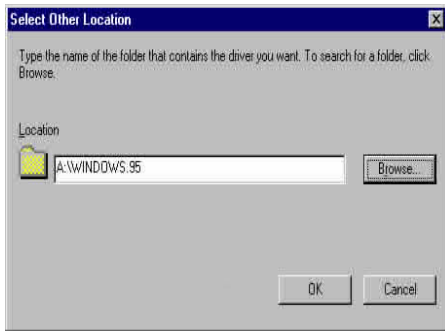

4. Click **[Finish]** button.



3. Select **Other Devices** and click **[Next]** button.

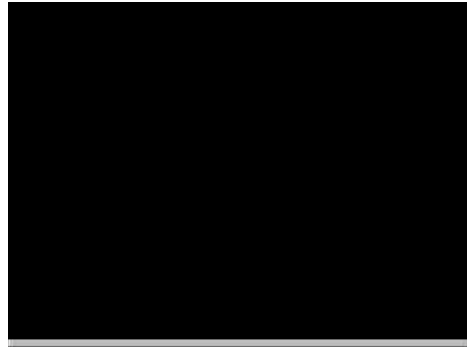

4. Click **[Have Disk]** button.

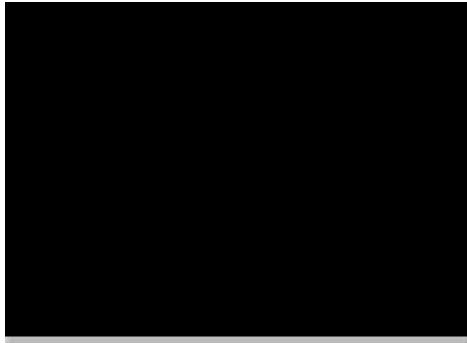

5. Type A:\Windows.95 and click **[OK]** button. The system will start reading the files from the diskette.

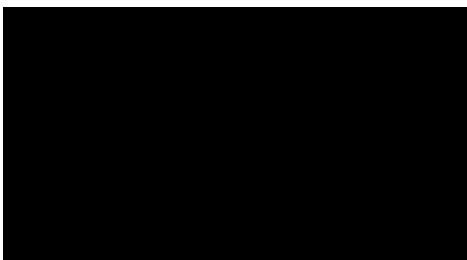

6. Click [**Next**] button.

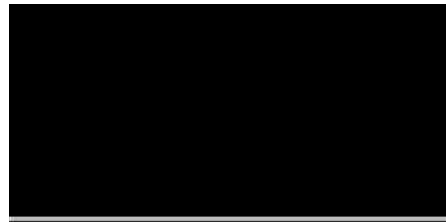

7. Click [**Next**] button.



### **Port Configuration Stage**

After the driver is installed, **C168 PCI Series Installation** dialog box will be displayed automatically and the port mapping is automatically done by the system.

If one MOXA C168H/PCI board had installed previously and another MOXA C168H/PCI board was plugged, the system will prompt you to do port configuration directly discussed in this section.

1. Click on a specific port.
2. Click [**Port Setting**] button to open **Port X** dialog box.

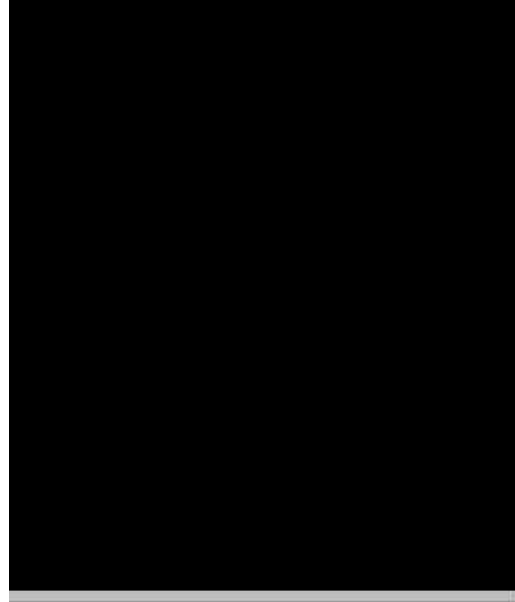

3. Select a COM number for the specific port from **Port Number** pull-down list.

**Note!** Step 4 is optional, if you want to assign COM numbers to Ports manually.

4. Check **Auto Enumerating COM Number** check-box then the subsequent ports are mapped to continuous COM numbers. For example, if COM 3 is assigned to Port 1, then COM 4 will be automatically assigned to Port 2.

**Note!** You may skip Step 5 to 8, if the system doesn't require a special performance tuning.

5. Select an Rx FIFO Trigger from **Rx FIFO Trigger** pull-down list.

Rx FIFO trigger levels, at 1, 4, 8 or 14 bytes, are available, and the default value is 14 bytes.

6. Check **Set the change to all ports** check-box then if desire to apply Rx FIFO Trigger just defined to all ports.

7. Select a Tx FIFO Size from Tx FIFO Size pull-down list.

Tx FIFO sizes from 1 to 16 bytes are available, and the default value is 16 bytes.

8. Check **Set the change to all ports** check-box then the if desire to apply Tx FIFO Size just defined to all ports.

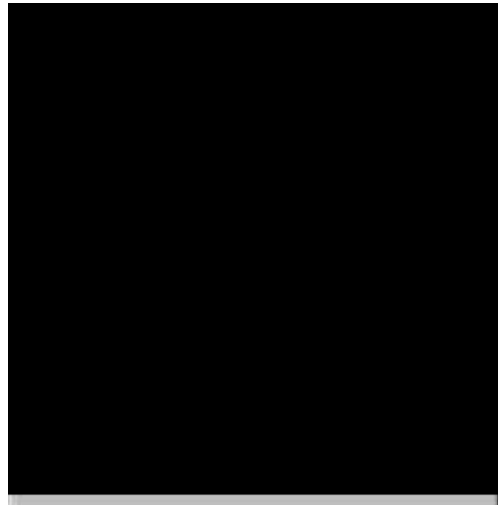

9. Click **[OK]** button in **Port X** dialog box to confirm the port setting.

10. Click **[OK]** button in **Property** dialog box to complete the port setting.

---

## Board and Port Ready Stage

**Board and Port Ready Stage** for Windows 95 and Windows 98 is a slight different.

In this last stage, you will complete the driver installation.

### Windows 95

After the port configuration, you can immediately use the COM ports of the *Smartio* C168H/PCI board without restarting Windows 95.

### Windows 98

After the port configuration, click [**Finish**] button. The COM ports of the *Smartio* C168H/PCI board can be used without restarting Windows 98.

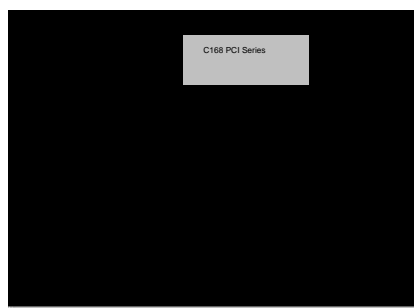

### Note!

If an error message similar to “**C168 PCI (BusNo=x, DevNo=x, Port1=COMx) interrupt number is invalid!**” pops up, refer to “Troubleshooting” chapter for solutions.

If you want to add more boards while the driver has been installed, simply plug the *Smartio* C168H/PCI board and Windows 95/98 will automatically detect the newly plugged board and skip to **Port Configuration stage** to do port setting.

Up to now, the driver installation of the *Smartio* C168H/PCI is complete and successful, including the board and port configuration. However, if changes of the board and port configuration are needed, please refer to the next section, “**Configuring Board and Port**”, for more configuration details.

Once the board and the driver are installed and the driver restarts successfully, you can start to develop applications with the *PComm* library (See “**Serial Programming Tools**”) or the Microsoft Win32 API. You can also execute any ready-made applications, such as *PComm* utility Terminal emulator (See “**Serial Programming Tools**”) or HyperTerminal to transmit/receive data, as well as Remote Access

Service to provide dial-up networking capabilities.

## Configuring Board and Port

If desire to re-configure the COM number for the ports of installed boards and drivers under Windows 95/98, please follow procedures listed below.

Instead of following procedures listed below, it is also allowed to do so by clicking **[Start] è [Program Files] è [MOXA Utility] è [Moxa Smartio/Industio Configuration Panel] è [Property] è [Port Setting]**.

For this is a PCI board, once the board is added or unplugged, the configuration will be automatically added or removed by the system. Thus, it saves your effort to do add or remove action.

1. Open **[Control Panel]**, click **[System]** icon, select **[Device Manager]** tab, and then select Moxa Smartio/Industio multiport board.
2. Click on desired C168H/PCI board entry, and click **[Properties]** button.

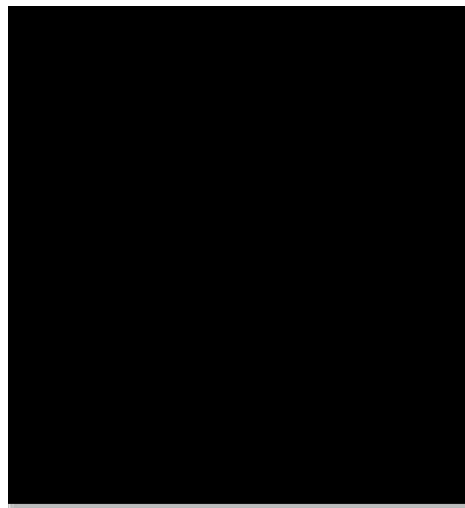

3. Select **[Ports Configuration]** tab.

- 
- Click on the specific port and click [**Port Setting**] button to re-assign the desired COM number for the *Smartio* C168H/PCI port mapping.

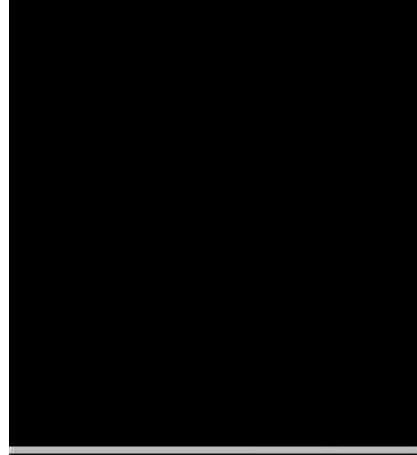

**Note!** Step 5 is optional, if you want to assign COM numbers to Port manually.

- Check **Auto Enumerating COM Name** check-box to assign continuous COM numbers for subsequent ports. For example, if COM 3 is assigned to Port 1, then COM 4 will be automatically assigned to Port 2.

**Note!** Step 6 and 7 are optional, if the system doesn't require a special performance tuning.

- Re-assign the Rx FIFO Trigger by selecting a number from the pull-down list. Check **Set the change to all ports** check-box if desire to apply this setting to all ports.

Rx FIFO trigger levels, at 1, 4, 8 or 14 bytes, are available, and the default value is 14 bytes.

- Re-assign the Tx FIFO Size by selecting a number from the pull-down list. Check **Set the change to all ports** check-box if desire to apply this setting to



all ports.

Tx FIFO sizes from 1 to 16 bytes are available, and the default value is 16 bytes.

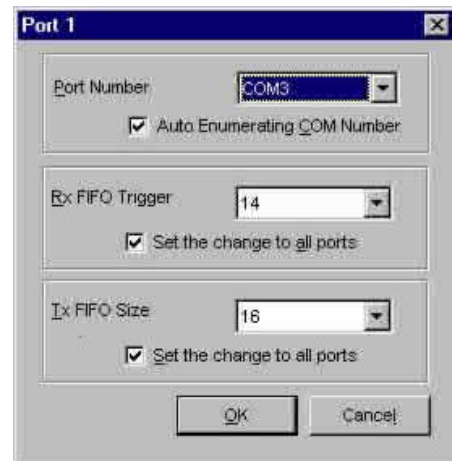

8. Click [OK] button in **Port X** dialog box.
9. Click [OK] button in **C168 PCI Series Properties** dialog box.
10. Click [OK] button in **Device Manager** tab.
11. Restart the system to activate the latest configuration.

## Updating Driver

This section will discuss how to update the Windows 95/98 driver to enhance the function of the board.

1. Open [Control Panel], click [System] icon, and select [Device Manager] tab.
2. Click on **MOXA C168 PCI Series** and click [Properties] button

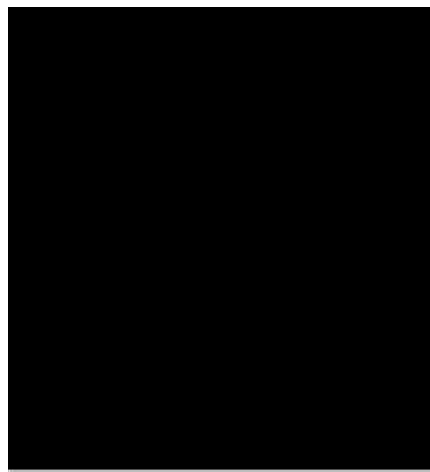

3. Select [**Driver**] tab.
4. Click [**Update Driver...**] button.

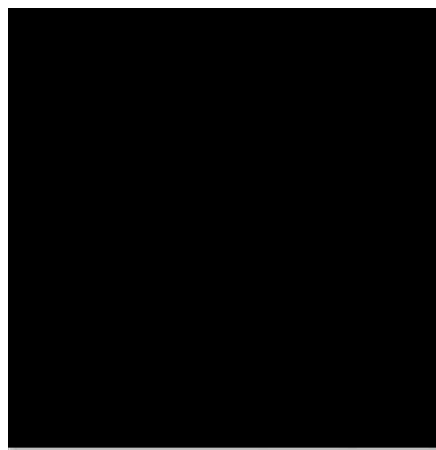

5. Click [**Have Disk...**] button and type the path of the new driver.
6. Insert the source diskette in the floppy drive if there is any.

7. Click [**OK**] button in **Install from Disk** dialog box.
8. The system will automatically prompt you to restart the system, click [**Yes**] button to restart the system. Or [**No**] button if you want to reboot the system later.

## Removing driver

This section explains how to remove the *Smartio* C168H/PCI board driver.

1. Open [**Control Panel**] icon, double click [**Add/Remove Programs**] icon, and then select [**Install/Uninstall**] tab.
2. Click on **MOXA Smartio/Industio Driver** option and then click [**Add/Remove**] button to start the driver removal.



3. Click [**Yes**] button in the following shown message box to confirm the driver removal.

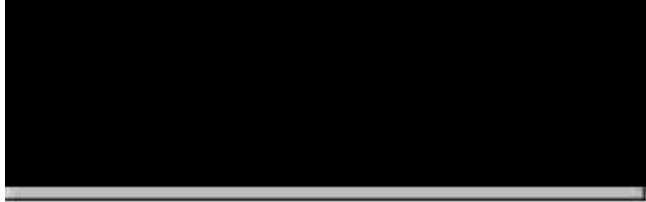

4. Click **[OK]** button in **Add/Remove Programs Properties** dialog box.

# 4

## Serial Programming Tools

Moxa supports some easy but powerful serial programming libraries and communication troubleshooting utilities under Windows NT and Windows 95/98. It will save your developing time with the MOXA Serial Programming Tools.

The following sections will detail the installation, the library and the utilities for various platforms.

*PComm*, the professional serial comm tool for PC, is a software package for **Windows NT** and **Windows 95/98** consisting of:

- 1 a powerful serial communication library for easy programming in the most popular languages. The serial communication library is useful for developing an application for data communication, remote access, data acquisition or industrial control in Windows NT or Windows 95/98 environment. Also it is an easier solution compared to the more complex Windows Win32 COMM API.
- 1 useful utilities such as diagnostic, monitor and terminal emulator,
- 1 illustrative sample programs and
- 1 comprehensive on-line documents.

### *PComm* Installation

To install *PComm*, run **\Setup.exe** from the diskette enclosed in the package. Please note that the *PComm* diagnostic and monitor utilities are for MOXA boards only; therefore, these two utilities won't work on other serial boards but only on MOXA boards.

After *PComm* is successfully installed, simply click **[Start]** and select **[Program Files]** and the **[PComm Lite]** group to select a list of utilities and documents.

---

## *PComm* Programming Library

The serial communication library helps you to develop programs for serial communications **for any COM port** complying with Microsoft Win32 API. It facilitates the implementation of multi-process and multi-thread serial communication programs and hence remarkably reduces developing time.

This serial communication library provides a complete library function and sample programs for Visual C++, Visual Basic and Delphi. To view the detailed function description and sample programs, please click [**Start**]è [**Program Files**] è [*PComm Lite*]è [*PComm Lib Help*], [*PComm Porting Notes*] or [*PComm Programming Guide*] or refer to the sample programs in the *PComm* directory.

## Utility

The followings are brief descriptions of each utility. For more information about each utility, please see the on-line help in the diskette.

### **Diagnostic (for MOXA boards only)**

A convenient diagnostic program ONLY for MOXA boards and ports provides internal and external testing including IRQ, TxD/RxD, UART, CTS/RTS, DTR/DSR, DTR/DCD testing, etc. It will verify if both the software and hardware function correctly.

To run Diagnostic program, click [**Start**] and select [**Program Files**] and [**PCComm Lite**] and [**Diagnostic**].



---

## Monitor (for MOXA boards under Windows NT Only)

A useful port status monitoring program allows you to watch over the selected MOXA COM ports. It monitors data transmitting/receiving throughput and communication line status that are updated and displayed on the screen at time intervals. By clicking on the specific displayed port, you can visualize the current communication parameters and status of that port.

To run Monitor program, click [Start] and select [Program Files] and [*PComm Lite*] and [Monitor].

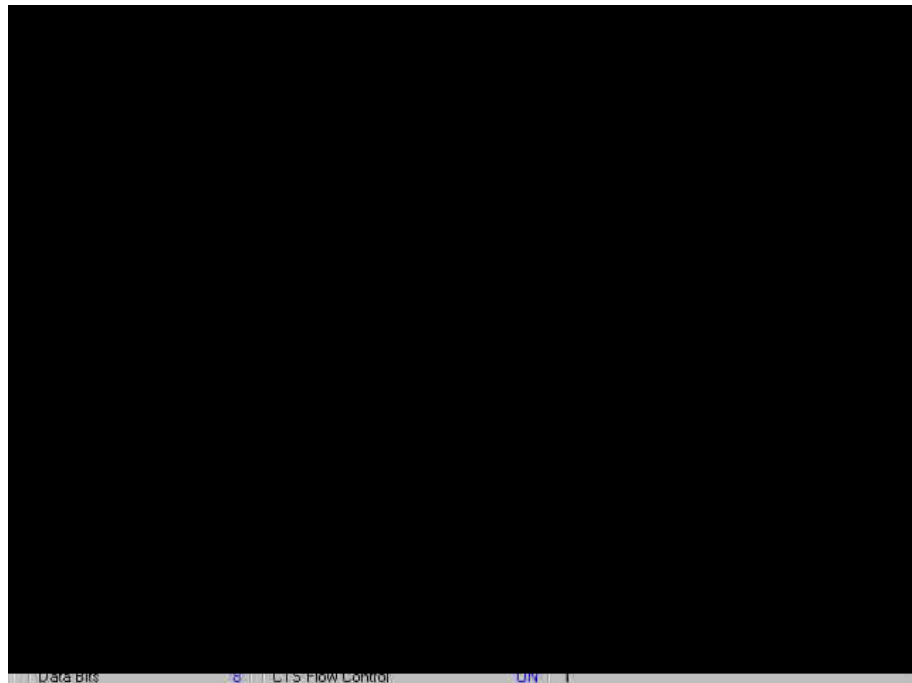



## Terminal Emulator

The **Terminal Emulator** obviously serves as an emulator to “connect” various ports to see if the transmission functions correctly. It features multi-windows and supports terminal types of VT100 and ANSI. It allows you to transfer data interactively, send pattern periodically or transfer file using ASCII, XMODEM, YMODEM, ZMODEM and KERMIT protocols.

To run Terminal Emulator program, click [**Start**] and select [**Program Files**] and [**PComm Lite**] and [**Terminal Emulator**].



---

## RS-485 Programming for Opt8J

If you intend to do RS-485 communication with Opt8J, please follow the RS-485 programming guide below and also refer to Chapter “**Connection Option (Opt8x) and Cable Wiring**” for more Opt8J RS-485 operation details.

The Opt8J supports **only 2-wire half-duplex RS-485 communication**. Data+/- pins are served for both data transmitting and receiving, depending on the RTS signal.

The port switch of each port should be set to **On** position. The port is for transmitting data if **RTS is asserted** and for receiving data if **RTS is not asserted**.

**RTS** scheme is suitable for any system, including Windows NT and Windows 95/98, DOS, or UNIX, that permits RTS control from application programs.

### How to transmit and receive data under Windows NT and Windows 95/98

We recommend you to configure *Smartio* C168H/PCI ports as follows in order to acquire precise timing control in RS-485 2-wire transmission.

There are 2 solutions to control RS-485 2-wire transmission.

#### Solution 1

The following model is common in RS-485 2-wire transmission.

```
sio_SetWriteTimeouts(port, 0);    /* Set sio_write() into block mode */
sio_RTS(port, 1);                /* Turn on RTS signal. The RS-485 port is ready for t
ransmitting data. */
sio_write(port, buff, 10);        /* Write 10 byte characters in "buff". The function bl
ocks until last character transmitted */
sio_RTS(port, 0);                /* Turn off RTS signal. The RS-485 port is ready for
receiving data. */
sio_read(port, buff, 10);         /* Read 10 bytes */
```

**Solution 2**

There's a dedicated RS-485 function in *PComm* library. It integrates the above functions of solution 1 regarding sending data as one.

```
sio_putb_x(port, buff, tick ); /*
```

1. Turn on RTS and ready for transmitting data.
2. Send data.
3. Wait for tick time.
4. Turn off RTS and ready for receiving data. \*/

For more information on these functions, please refer to *PComm* library on-line Help file for Windows NT and Windows 95/98.



# 5

## Connection Option (Opt8x) & Cable Wiring

In serial data communications, the term **DTE** is for Data Terminal Equipment like terminal or PC COM1/2. The term **DCE** is for Data Communication Equipment like modem. Their precise pinouts and cable wiring are as follows.

### RS-232 Cable Wiring for Opt8A/B/C/D/S

RS-232 8-port connection boxes/octopus cable designed for *Smartio* C168H/PCI are:

**Opt8A:** 8-port RS-232 DB25 female connection box

**Opt8B:** 8-port RS-232 DB25 male connection box

**Opt8C:** Octopus cable with 8 male RS-232 DB25 ports

**Opt8D:** Octopus cable with 8 male RS-232 DB9 ports

**Opt8S:** 8-port RS-232 DB25 surge protected female connection box

---

The followings are pin assignments for various connection options:

**Opt8A/S**  
**(DCE, DB25 Female)**

---

- 2 RxD
- 3 TxD
- 4 CTS
- 5 RTS
- 6 DTR
- 7 GND
- 8 DCD
- 20 DSR

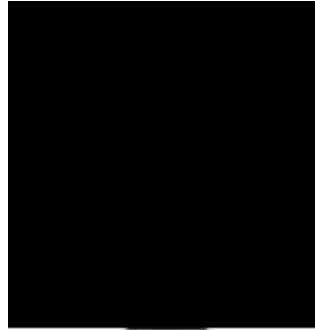

**Opt8B/C**  
**(DTE, DB25 Male)**

---

- 2 TxD
- 3 RxD
- 4 RTS
- 5 CTS
- 6 DSR
- 7 GND
- 8 DCD
- 20 DTR

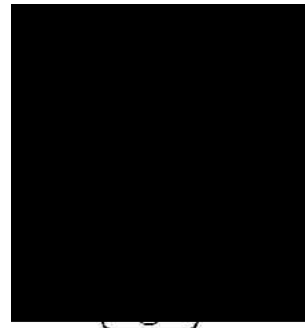

**Opt8D**  
**(DTE, DB9 Male)**

---

- 1 DCD
- 2 RxD
- 3 TxD
- 4 DTR
- 5 GND
- 6 DSR
- 7 RTS
- 8 CTS

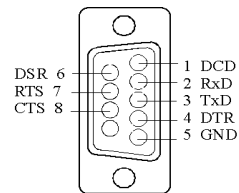

**Type 1: To connect *Smartio* C168H/PCI to a DTE device.**

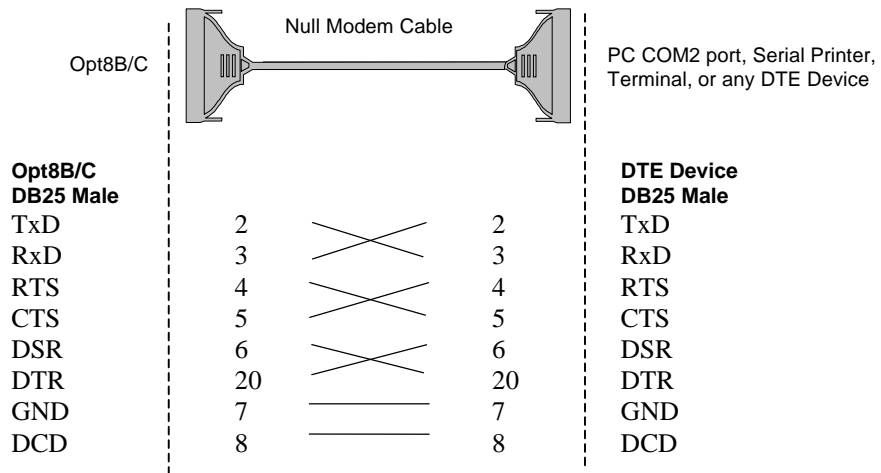
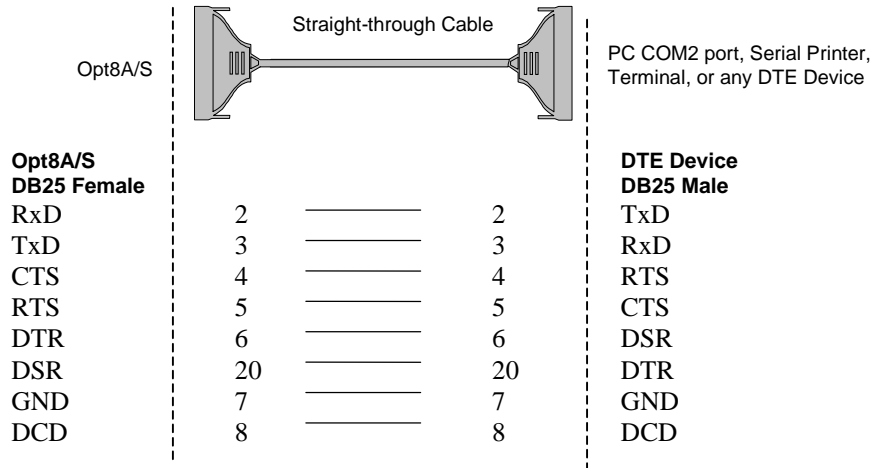

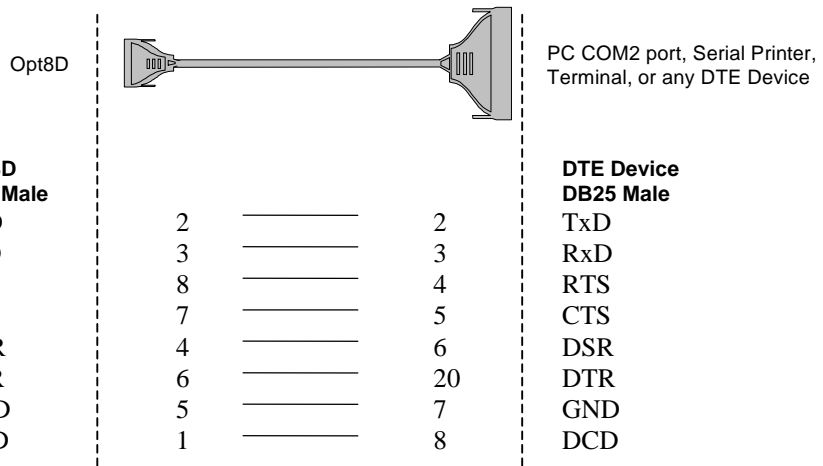

**Type 2: To connect *Smartio C168H/PCI* to a DCE device.**

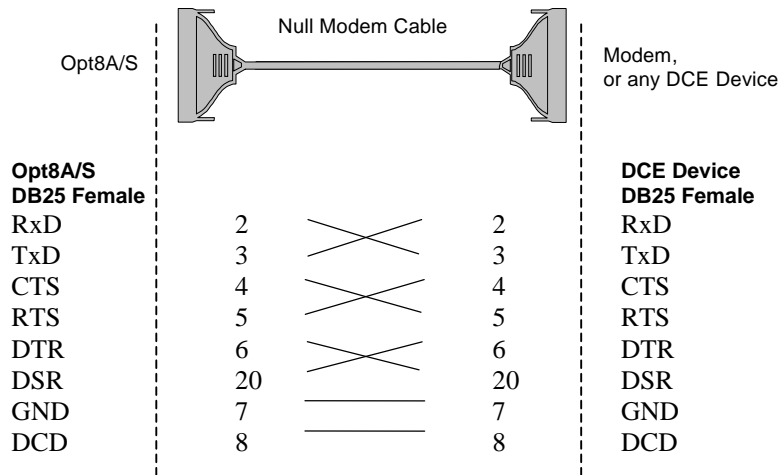



Connection Option (Opt8x) and Cable Wiring

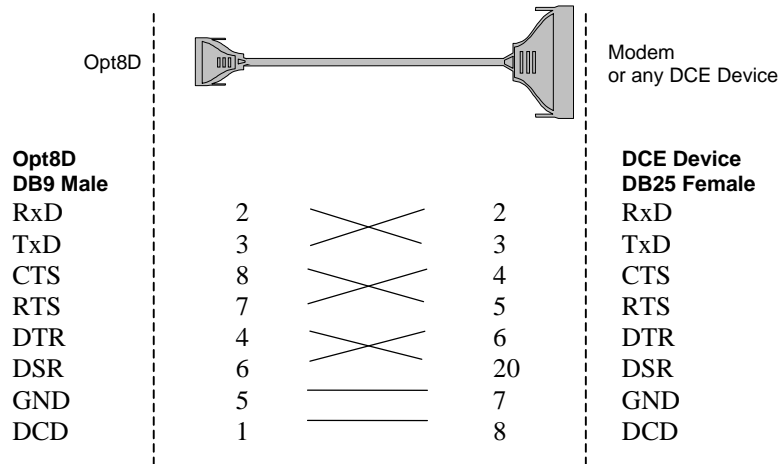
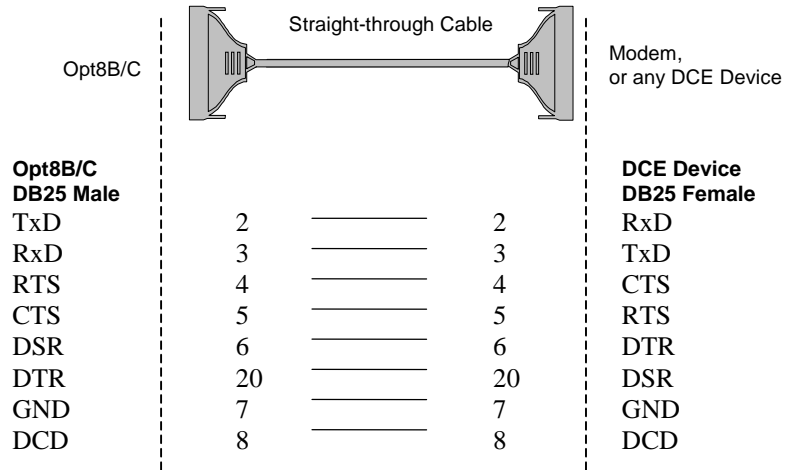

**Type 3: To connect *Smartio C168H/PCI* to a DTE with 3-pin wiring.**

If the “**Hardware flow control**” feature is set to “**ON**”, you must loop back (or short) the RTS with CTS and DSR with DTR, DCD on MOXA site, indicated in dash-lines of the following diagrams. If the “**Hardware flow control**” feature is set to “**OFF**”, you could just leave RTS, CTS, DSR, DTR, DCD open, ignoring the connection indicated in dash-lines.

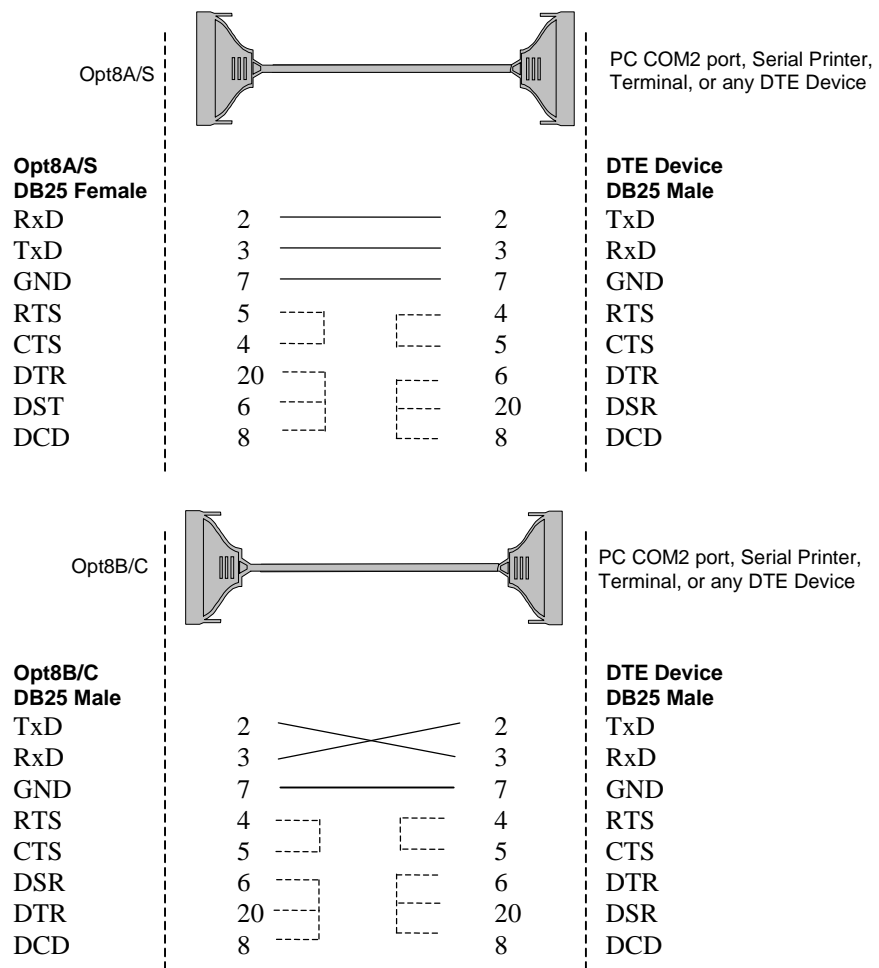

Connection Option (Opt8x) and Cable Wiring

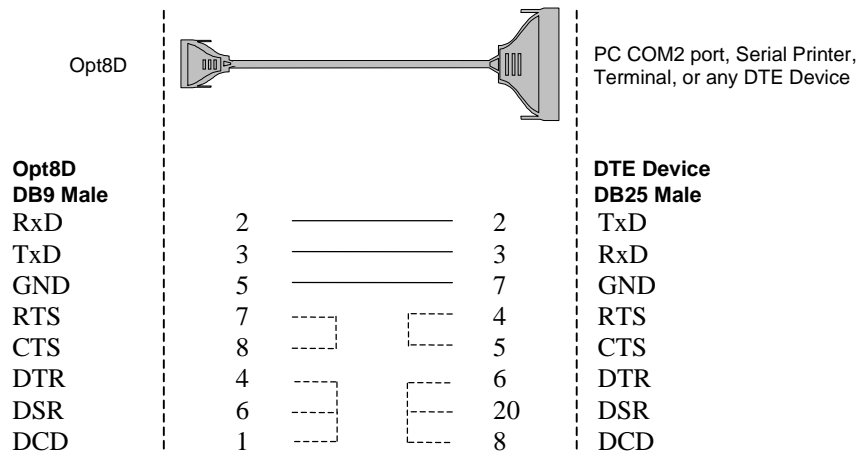

---

## RS-422 Cable Wiring for Opt8J/F/Z

RS-422 connection boxes designed for *Smartio* C168H/PCI boards are:

**Opt8J:** Connection box with 8 female RS-422/485 DB25 ports. Set the port switch to **OFF** position (RS-422) for the desired port(s).

**Opt8F:** Connection box with 8 female RS-422 DB25 ports and Max. 500V DC isolation protection which prevents damage caused by high potential voltage.

**Opt8Z:** Connection box with 8 female RS-422 DB25 ports but without isolation protection.

### RS-422 Pinouts for Opt8J/F/Z: pt8J/F/Z

---

2	RxD+(B)	} <b>Opt8J only</b>
3	TxD+(B)	
14	RxD-(A)	
16	TxD-(A)	
7	GND	
4	CTS+(B)	
5	RTS+(B)	
13	RTS-(A)	
19	CTS-(A)	

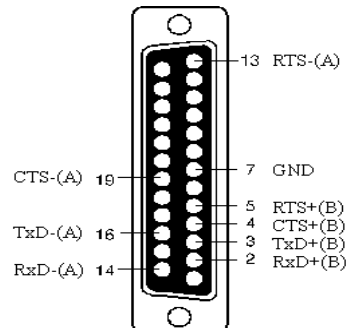

The RS-422 transmission distance can reach as long as 4000ft. The connection box needs an external power adapter to supply 5V DC power. Either 110V or 220V AC power adapter is selectable.

The followings are operation modes for RS-422:

**RS-422 Point-to-point**

Opt8F/Z	RS-422 Device
3 TxD+(B)	RxD+(B)
16 TxD-(A)	RxD-(A)
2 RxD+(B)	TxD+(B)
14 RxD-(A)	TxD-(A)
7 GND	GND

**RS-422 Broadcasting**

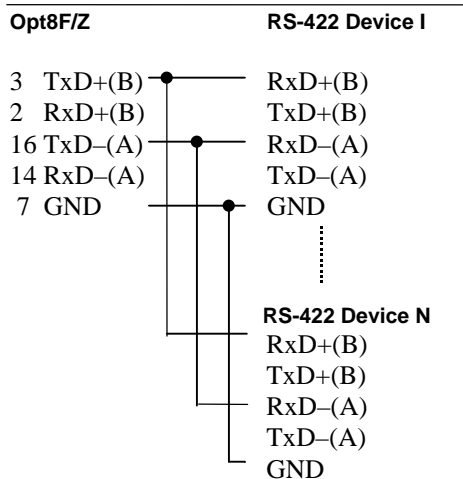

**Opt8J RS-422 with Handshaking**

Opt8J	RS-422 Device
3 TxD+(B)	RxD+(B)
16 TxD-(A)	RxD-(A)
2 RxD+(B)	TxD+(B)
14 RxD-(A)	TxD-(A)
7 GND	GND
5 RTS+(B)	CTS+(B)
13 RTS-(A)	CTS-(A)
4 CTS+(B)	RTS+(B)
19 CTS-(A)	RTS-(A)

## RS-485 Cable Wiring for Opt8J

One RS-485 connection box designed for *Smartio* C168H/PCI is:

**Opt8J:** Connection box with 8 female RS-422/485 DB25 ports. Set the port switch to **ON** position.

The Opt8J supports **only 2-wire half-duplex RS-485 communication**. **Data+/-** pins are served for both data transmitting and receiving, depending on the RTS signal.

RS-485 Pinouts for Opt8J:

Opt8J	
3	Data+(B)
7	GND
16	Data-(A)

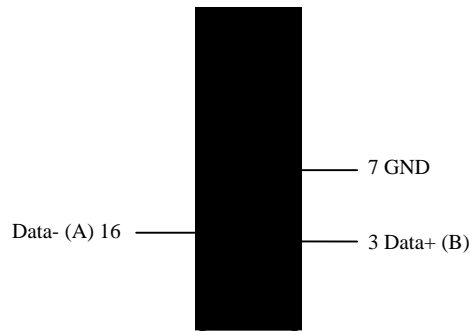

Multidrop RS-485 Half-duplex

Point-to-Point RS-485 Half-duplex

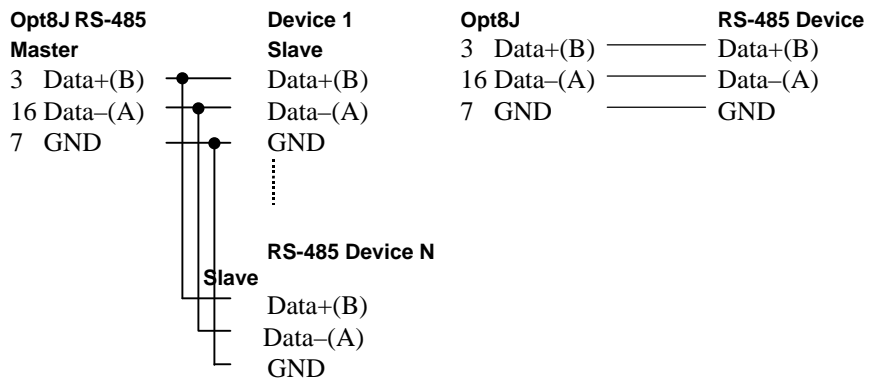





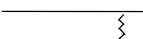
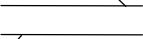

See Section “**RS-485 Programming**” of Chapter “**Serial Programming Tools**” for more Opt8J RS-485 programming details.

## RS-422/485 Impedance Matching

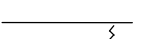
For RS-422/485 serial communications, when an electrical signal travels through two different resistance junctions in a transmission line, the impedance mismatch will sometimes cause signal reflection. Signal reflection causes signal distortion, which in turn will contribute communication errors. The solution to this problem is to establish the same impedance at the line ends as in the line itself by terminating them with resistors.

The value of the termination resistor should equal the characteristic impedance of the transmission line. The resistors should be added **near the receiving side**.

Opt8J/F/Z		RS-422/485 Device	
3	TxD+(B)		RxD+(B)
16	TxD-(A)		RxD-(A)
2	RxD+(B)		TxD+(B)
14	RxD-(A)		TxD-(A)
5	RTS+(B)		CTS+(B)
13	RTS-(A)		CTS-(A)
4	CTS+(B)		RTS+(B)
19	CTS-(A)		RTS-(A)

} **Opt8J only**

**Note:**

1.  Stands for termination resistor near the receiving side
2. The suggested termination resistor for AWG #26 cable is 100 ohm.
3. The suggested termination resistor for phone cable is 600 ohm.





# 6

## Troubleshooting

Common *Smartio* C168H/PCI errors and possible corresponding solutions are listed below. If the problem still cannot be solved by following solutions given, contact dealers or Moxa for help or use the **Problem Report Form** at the end of this manual to report problems to your dealer at once for faster technical support.

### General Troubleshooting

1. **The MOXA PCI board cannot be detected by the MOXA driver while installing the driver.**

#### Hardware causes and solutions:

- A. The board is not installed or missing (absent). Please install it.
- B. The board is not properly plugged in the system. If that is the case, re-plug the board in a 32-bit PCI slot this time. Sometimes the slot for plugging the board is malfunctioned. In this case, try other slots until you find a good one.
- C. The motherboard does not have an available IRQ for the C168H/PCI board. Please enter BIOS and make sure there are available IRQ in PCI/PnP settings.

2. **The MOXA board and driver are activated but cannot transfer (transmitting/receiving) data.**

#### Hardware Causes and Solutions:

- A. Check if cable wiring is connected correctly. Please refer to the “**Connection Option (Opt8x) and Cable Wiring**” chapter for correct cable connection.

- 
- B. The cable or the board are probably defective. Please try other ports, cables or boards to verify it. Or use *PComm* Diagnostic utility testing MOXA boards and port conditions. If Diagnostic reports error, replace the malfunctioned faulty components.

**Software Causes and Solutions:**

- A. Smartio C168H/PCI board will check the line status (CTS) before transmitting data if the RTS/CTS flow control feature is set to Enable in the configuration or application program. Please refer to the “**Connection Option (Opt8x) and Cable Wiring**” chapter for proper wiring and check the line status of the suspected port using the diagnostic LED indicators on the mini tester.
- B. The board controlling application might not be correctly written according to the corresponding API of the operating system. To verify the problem, please run another existing and known good application or the utilities provided by Moxa. Such as *Pcomm* Terminal emulator or HyperTerminal under Windows NT and Windows 95/98.

## Windows NT

This section is specific for troubleshooting under Windows NT. For general problems and solutions, please see the previous section, General Troubleshooting.

1. **After the system reboots, the error message Another driver in the system, which did not report its resources, has already claimed the interrupt used by xxx. appears in the Event Log.**

This indicates the MOXA board is found, but the IRQ is conflicting with another adapter. Please check the PCI BIOS IRQ settings first and then select an IRQ that is available.

2. **After the system reboots, the error message “Cannot find any configured MOXA Smartio/Industio series board!” appears in the Event Log.**

Please make sure the PCI board is seated firmly in the expansion slot.

3. **The COM number of the *Smartio* C168H/PCI (Bus No=x Dev No=x, Port1=COMx), with device number xx, conflicts with others.**

The COM numbers for different boards are conflicting. Change the COM number mappings for MOXA boards.

**4. Windows NT system panic (blue screen).**

The possible reason is an IRQ or I/O address conflict with other ISA Bus adapters, like LAN and SCSI boards, or the system BIOS. Please refer to the corresponding problem in the previous section “**General Troubleshooting**” for solutions.

## Windows 95/98

This section is specific for troubleshooting under Windows 95/98. For general problems and solutions, please see the previous section, “**General Troubleshooting**”.

**1. The system fails to find the *Smartio* C168H/PCI board!**

- The board(s) is(are) not plugged properly.

- The slot with boards plugging in is defective, please try another slot until you find a good one.

- The board might be defective.

**2. After the system reboots, the error message “C168H/PCI (BusNo=x, DevNo=x, Port1=COMx) interrupt number is invalid!” appears.**

This indicates that the MOXA board is found, but the IRQ is conflicting with other adapter. Make sure MOXA board’s IRQ is not conflicting with other adapter’s. Check the PCI BIOS IRQ settings and select an available IRQ for MOXA boards.



# A

## Technical Reference

### Specification

- √ Bus interface: 32-bit PCI (PCI Spec. 2.1 compliance)
- √ Number of ports: 8
- √ Max. boards: 4
- √ IRQ: Assigned by PCI BIOS
- √ I/O address: Assigned by PCI BIOS
- √ Speed (bps): 50 ~ 921.6K
- √ Data bits: 5, 6, 7, 8
- √ Stop bits: 1, 1.5, 2
- √ Parity: none, even, odd, space, mark
- √ UART: 8 »ë16C550C or compatible
- √ Data signals: RS-232»ëTxD, RxD, RTS, CTS, DTR, DSR, DCD, GND  
RS-422»ëTxD+/-, RxD+/-, GND (Opt8J: RTS+/-, CTS+/-)  
RS-485»ëData+/-, GND
- √ Connectors: 8 »ëDB25/DB9 male/female (DTE/DCE)
- √ Operating temp: 0 ~ 55 ¼[
- √ Power requirement: 180mA (+5V), 110mA (+12V), 160mA (-12V)
- √ Dimensions: 123mm»ë100mm
- √ Operating Systems: Window NT/95/98 and DOS

### PCI

The 32-bit *Smartio* C168H/PCI board complies with the PCI specifications 2.1. Hardware configuration for IRQ and I/O addresses is automatically assigned by the PCI BIOS. Hence, you must **first plug the board** before installing the software driver.

Unlike ISA slots, different PCI slots in the same PC may have different bus numbers and device numbers with respect to the PCI specifications. The same PCI board will have different system configurations if switching to a different PCI slot,

---

which may be called **slot-sensitive** or **slot-dependent**. This may also apply to PCI slots in PC with different motherboard, which may use **different device number sets**. For example, some use 17, 18, 19, and 20 for identifying the respective PCI slots but some use 11, 12, 13 and 14.

Due to the **slot-dependency**, it is necessary to **re-configure the software driver** once the board is plugged in different PCI slots.

Up to 4 *Smartio* C168H/PCI boards are allowed in one system. When installing more than one boards, **please remember the order of boards** for distinguishing the installed boards.

## UART 16C550C

The UART chip **16C550C** is an intelligent asynchronous controller supporting one full duplex channel that simultaneously transfers data at **921.6 Kbps** speed. To increase the overall data throughput, special features such as on-chip FIFO and on-chip hardware flow control are used to reduce the number of interrupts to the onboard CPU and to prevent any loss of valuable data.

## DB62 Connector Pinouts

The following lists the pin assignments of the **DB62** connector on the bracket.

Pin No.	Signal	Pin No.	Signal	Pin No.	Signal
1	TxD1	22	RxD1	43	CTS1
2	DTR1	23	DSR1	44	RTS1
		24	DCD1	45	GND
3	RxD2	25	TxD2	46	CTS2
4	DSR2	26	DTR2	47	RTS2
5	DCD2				
6	TxD3	27	RxD3	48	CTS3
7	DTR3	28	DSR3	49	RTS3
		29	DCD3	50	GND
8	RxD4	30	TxD4	51	CTS4
9	DSR4	31	DTR4	52	RTS4
10	DCD4	32	GND		
11	RxD5	33	TxD5	53	CTS5
12	DSR5	34	DTR5	54	RTS5
13	DCD5			55	GND
14	TxD6	35	RxD6	56	CTS6
15	DTR6	36	DSR6	57	RTS6
		37	DCD6	58	GND
16	RxD7	38	TxD7	59	CTS7
17	DSR7	39	DTR7	60	RTS7
18	DCD7	40	GND		
19	RxD8	41	TxD8	61	CTS8
20	DSR8	42	DTR8	62	RTS8
21	DCD8				





# Problem Report Form

## *Smartio C168H/PCI*

Customer name:	
Company:	
Tel:	Fax:
Email:	Date:

1. **Moxa Product:**  C168H/PCI Serial Number: \_\_\_\_\_
2. **Moxa Driver version:** \_\_\_\_\_
3. **Moxa hardware settings:** PCI Slot number \_\_\_\_\_
4. **Operating System:**  DOS  Windows 95/98  
 Windows NT 3.51  Windows NT 4.0  
 Others
5. **PC Host:** Make \_\_\_\_\_ Model \_\_\_\_\_
6. **CPU:** Speed \_\_\_\_\_ MHz Make \_\_\_\_\_ Model \_\_\_\_\_
7. **BIOS:** Make \_\_\_\_\_ Version \_\_\_\_\_
8. **PCI IRQ Configuration in BIOS:**

Slot no.	1	2	3	4
IRQ no				

9. **Problem Description:** Please describe the symptom as clear as possible including the error message you see. We may have to follow your description to reproduce the symptom.  
 Board not found.  Board found, but can't transfer data.  
 Can transfer data, but lose data  Can transfer data but with garbled data.  
 Others. Detailed error message description is recommended:

# Return Procedure

For product repair, exchange or refund, the customer must:

- ✓ Provide evidence of original purchase
- ✓ Obtain a Product Return Agreement (PRA) from the sales representative or dealer
- ✓ Fill out the Problem Report Form (PRF) as detailed as possible for shorter product repair time.
- ✓ Carefully pack the product in anti-static package, and send it, pre-paid, to the dealer. The PRA should show on the outside of the package, and include a description of the problem along with the return address and telephone number of a technical contact.