

TEC

TEC Thermal Printer

B-670/680-QQ SERIES

Owner's Manual

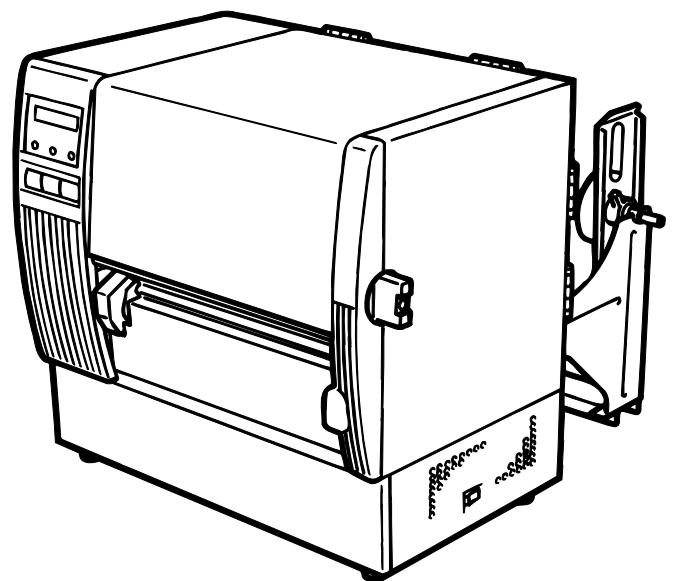

TOSHIBA TEC CORPORATION

This equipment has been tested and found to comply with the limits for a Class A digital device, pursuant to Part 15 of the FCC Rules. These limits are designed to provide reasonable protection against harmful interference when the equipment is operated in a commercial environment. This equipment generates, uses, and can radiate radio frequency energy and, if not installed and used in accordance with the instruction manual, may cause harmful interference to radio communications. Operations of this equipment in a residential area is likely to cause harmful interference in which case the user will be required to correct the interference at his own expense. (for USA only)

Changes or modifications not expressly approved by manufacturer for compliance could void the user's authority to operate the equipment.

"This Class A digital apparatus meets all requirements of the Canadian Interference-Causing Equipment Regulations."

"Cet appareil numérique de la classe A respecte toutes les exigences du Règlement sur le matériel brouilleur de Canada."

(for CANADA only)

WARNING!

This is a Class A product. In a domestic environment this product may cause radio interference in which case the user may be required to take adequate measures.

CAUTION:

Do not touch moving parts. To reduce the risk that fingers, jewelry, clothing, etc., be drawn into the moving parts, push the switch in the "OFF" position to stop movement.

As an ENERGY STAR® Partner, TOSHIBA TEC has determined that this product meets the ENERGY STAR® guidelines for energy efficiency.



-- Outline of the International ENERGY STAR® Office Equipment Program --

The International ENERGY STAR® Office Equipment Program is an international program that promotes energy saving through the penetration of energy efficient computers and other office equipment. The program backs the development and dissemination of products with functions that effectively reduce energy consumption. It is an open system in which business proprietors can participate voluntarily. The targeted products are office equipment such as computers, monitors, printers, facsimiles, copiers, scanners, and multifunction devices. Their standards and logos are uniform among participating nations.

ENERGY STAR is a U.S. registered mark.

Safety Summary

Personal safety in handling or maintaining the equipment is extremely important. Warnings and Cautions necessary for safe handling are included in this manual. All warnings and cautions contained in this manual should be read and understood before handling or maintaining the equipment. Do not attempt to effect repairs or modifications to this equipment. If a fault occurs that cannot be rectified using the procedures described in this manual, turn off the power, unplug the machine, then contact your authorized TOSHIBA TEC representative for assistance.

Meanings of Each Symbol



This symbol indicates warning items (including cautions). Specific warning contents are drawn inside the \triangle symbol. (The symbol on the left indicates a general caution.)



This symbol indicates prohibited actions (prohibited items). Specific prohibited contents are drawn inside or near the \circ symbol. (The symbol on the left indicates "no disassembling".)



This symbol indicates actions which must be performed. Specific instructions are drawn inside or near the \bullet symbol. (The symbol on the left indicates "disconnect the power cord plug from the outlet".)



WARNING

This indicates that there is the risk of **death or serious injury** if the machines are improperly handled contrary to this indication.



Any other than the specified AC voltage is prohibited.

■ Do not use voltages other than the voltage (AC) specified on the rating plate, as this may cause **fire** or **electric shock**.

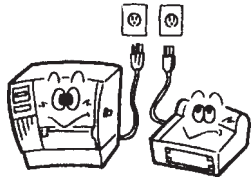

Prohibited

■ Do not plug in or unplug the power cord plug with wet hands as this may cause **electric shock**.

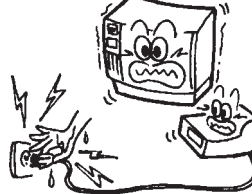

Prohibited

■ If the machines share the same outlet with any other electrical appliances which consume large amounts of power, the voltage will fluctuate widely each time these appliances operate. Be sure to provide an exclusive outlet for the machine as this may cause the machines to **malfunction**.



Prohibited

■ Do not place metal objects or water-filled containers such as flower vases, flower pots or mugs, etc. on top of the machines. If metal objects or spilled liquid enter the machines, this may cause **fire** or **electric shock**.

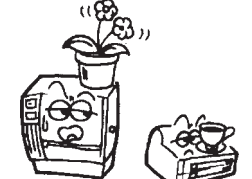

Prohibited

■ Do not insert or drop metal, flammable or other foreign objects into the machines through the ventilation slits, as this may cause **fire** or **electric shock**.

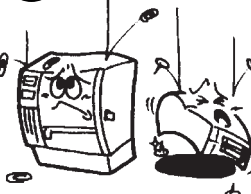

Prohibited

■ Do not scratch, damage or modify the power cords. Also, do not place heavy objects on, pull on, or excessively bend the cords, as this may cause **fire** or **electrical shock**.

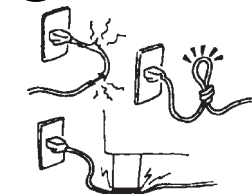

Disconnect the plug.







■ If the machines are dropped or their cabinets damaged, first turn off the power switches and disconnect the power cord plugs from the outlet, and then contact your authorized TOSHIBA TEC representative for assistance. Continued use of the machine in that condition may cause **fire** or **electric shock**.

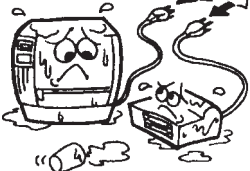

Disconnect the plug.

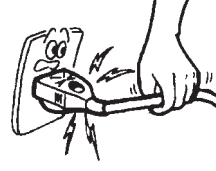
■ Continued use of the machines in an abnormal condition such as when the machines are producing smoke or strange smells may cause **fire** or **electric shock**. In these cases, immediately turn off the power switches and disconnect the power cord plugs from the outlet. Then, contact your authorized TOSHIBA TEC representative for assistance.

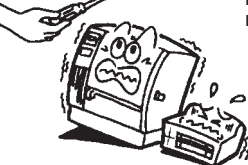

 <p>Disconnect the plug.</p>  <p>■ If foreign objects (metal fragments, water, liquids) enter the machines, first turn off the power switches and disconnect the power cord plugs from the outlet, and then contact your authorized TOSHIBA TEC representative for assistance. Continued use of the machine in that condition may cause fire or electric shock.</p>	 <p>Disconnect the plug.</p>  <p>■ When unplugging the power cords, be sure to hold and pull on the plug portion. Pulling on the cord portion may cut or expose the internal wires and cause fire or electric shock.</p>
 <p>Connect a grounding wire.</p>  <p>■ Ensure that the equipment is properly grounded. Extension cables should also be grounded. Fire or electric shock could occur on improperly grounded equipment.</p>	 <p>No disassembling.</p>  <p>■ Do not remove covers, repair or modify the machine by yourself. You may be injured by high voltage, very hot parts or sharp edges inside the machine.</p>



CAUTION This indicates that there is the risk of personal **Injury** or **damage** to objects if the machines are improperly handled contrary to this indication.

Precautions

The following precautions will help to ensure that this machine will continue to function correctly.

- Try to avoid locations that have the following adverse conditions:
 - * Temperatures out of the specification
 - * Direct sunlight
 - * High humidity
 - * Shared power source
 - * Excessive vibration
 - * Dust/Gas
- The cover should be cleaned by wiping with a dry cloth or a cloth slightly dampened with a mild detergent solution. NEVER USE THINNER OR ANY OTHER VOLATILE SOLVENT on the plastic covers.
- USE ONLY TOSHIBA TEC SPECIFIED paper and ribbons.
- DO NOT STORE the paper or ribbons where they might be exposed to direct sunlight, high temperatures, high humidity, dust, or gas.
- Ensure the printer is operated on a level surface.
- Any data stored in the memory of the printer could be lost during a printer fault.
- Try to avoid using this equipment on the same power supply as high voltage equipment or equipment likely to cause mains interference.
- Unplug the machine whenever you are working inside it or cleaning it.
- Keep your work environment static free.
- Do not place heavy objects on top of the machines, as these items may become unbalanced and fall causing **injury**.
- Do not block the ventilation slits of the machines, as this will cause heat to build up inside the machines and may cause **fire**.
- Do not lean against the machine. It may fall on you and could cause **injury**.
- Care must be taken not to injure yourself with the printer paper cutter.
- Unplug the machine when it is not used for a long period of time.

Request Regarding Maintenance

- Utilize our maintenance services.
After purchasing the machine, contact your authorized TOSHIBA TEC representative for assistance once a year to have the inside of the machine cleaned. Otherwise, dust will build up inside the machines and may cause a **fire** or a **malfunction**. Cleaning is particularly effective before humid rainy seasons.
- Our preventive maintenance service performs the periodic checks and other work required to maintain the quality and performance of the machines, preventing accidents beforehand. For details, please consult your authorized TOSHIBA TEC representative for assistance.
- Using insecticides and other chemicals
Do not expose the machines to insecticides or other volatile solvents. This will cause the cabinet or other parts to deteriorate or cause the paint to peel.

TABLE OF CONTENTS

	Page
1. INTRODUCTION	1- 1
1.1 APPLICABLE MODEL	1- 1
1.2 ACCESSORIES	1- 1
2. SPECIFICATIONS	2- 1
2.1 PRINTER	2- 1
2.2 OPTIONS	2- 2
2.3 MEDIA	2- 3
2.4 RIBBON	2- 3
3. OVERVIEW	3- 1
3.1 FRONT/REAR VIEW	3- 1
3.2 OPERATION PANEL	3- 1
4. DIP SWITCH FUNCTIONS	4- 1
5. SET UP PROCEDURE	5- 1
5.1 REQUIREMENTS FOR OPERATION	5- 1
5.2 SETTING UP THE PRINTER	5- 1
6. INSTALLING THE PRINTER	6- 1
6.1 CONNECTING THE POWER CORD AND CABLES	6- 1
6.2 HOLDER STAND INSTALLATION	6- 1
7. LOADING THE RIBBON	7- 1
8. LOADING THE MEDIA	8- 1
9. INSERTING THE OPTIONAL FLASH MEMORY CARD	9- 1
10. INSERTING THE OPTIONAL PCMCIA CARD	10- 1
11. CARE/HANDLING OF THE MEDIA AND RIBBON	11- 1
12. GENERAL MAINTENANCE	12- 1
12.1 CLEANING	12- 1
12.2 UNDER THE MEDIA GUIDES	12- 3
12.3 COVERS AND PANELS	12- 3
12.4 REMOVING JAMMED MEDIA	12- 4
12.5 THRESHOLD SETTING	12- 6
13. TROUBLESHOOTING	13- 1

CAUTION:

1. *This manual may not be copied in whole or in part without prior written permission of TOSHIBA TEC.*
2. *The contents of this manual may be changed without notification.*
3. *Please refer to your local Authorized Service representative with regard to any queries you may have in this manual.*

1. INTRODUCTION

Thank you for choosing the TEC B-672/682 Series thermal/transfer printer. This new generation high performance/quality printer is equipped with the latest hardware including the newly developed high density (12 dot/mm, 305 dot/inch) edge print head. This will allow very clear print at a maximum speed of 203.2 mm/sec. (8 inch/sec.). Other standard features include an external media supply. Optional features include a strip mechanism and Cutter mechanism.

This manual contains general set-up and maintenance information and should be read carefully to help gain maximum performance and life from your printer. For most queries please refer to this manual and keep it safe for future reference.

1.1 APPLICABLE MODEL

- B-672-QQ
- B-682-TS10-QQ
- B-682-TS10-QQ-US

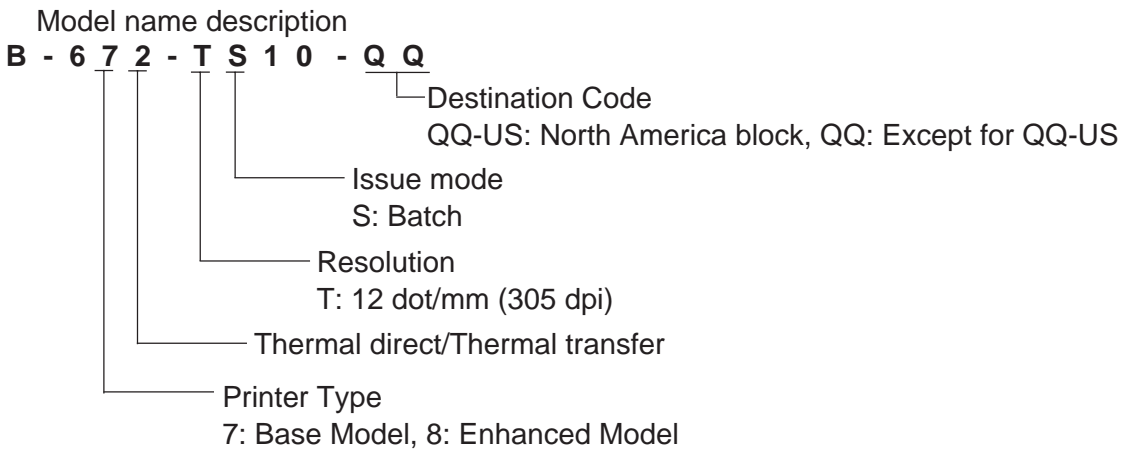

1.2 ACCESSORIES

Owner's Manual
(EO1-33015)



Power Cord

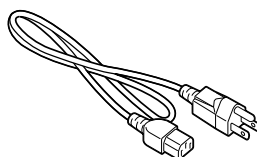

Print Head Cleaner
(24089500013)



Media Holder

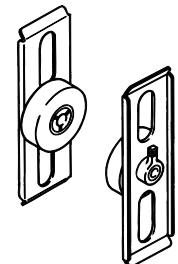

Holder Shaft



Left/Right Side Holder

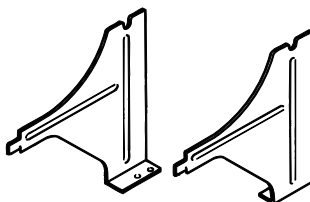

Holder Base

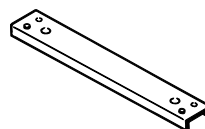

Thumbscrew
(M-4x6)

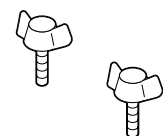

Quality control report

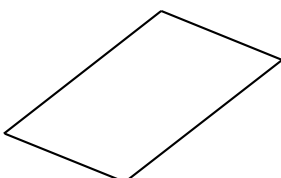

2. SPECIFICATIONS

2.1 PRINTER

Item	Model	B-672/682-QQ
Supply voltage		Universal (automatic switching) 85-138 V, 50/60 Hz 187-276 V, 50/60 Hz Be sure to use a power cord which meets the standard.
Power consumption		3.5 A, 260 W maximum (standby: 360 mA, 20 W maximum)
Operating temperature range		5°C ~ 40°C
Relative humidity		25% ~ 85%RH (no condensation)
Print head		Thermal print head 12 dots per mm (305 dots per inch)
Printing methods		Thermal direct or Thermal transfer
Print speeds		76.2 mm/sec. (3 inch/sec.), 101.6 mm/sec. (4 inch/sec.), 203.2 mm/sec. (8 inch/sec.)
Maximum print width		170.6 mm (6.72 inches)
Dispensing modes		Batch (Continuous), Strip (On-demand) and Cut modes (Both cut and strip modes are available only when their respective modules are fitted.)
Message display		20 characters x 1 line
Dimensions		437 mm (width) x 282 mm (depth) x 395 mm (height)
Weight		B-672: 25 kg (without media and ribbon) B-682: 26 kg (without media and ribbon)
Available bar-code types		JAN8, JAN13, EAN8, EAN8 + 2 digits, EAN8 + 5 digits EAN13, EAN13 + 2digits, EAN13 + 5 digits UPC-E, UPC-E + 2 digits, UPC-E + 5 digits UPC-A, UPC-A + 2 digits, UPC-A + 5 digits MSI, ITF, NW-7, CODE39, CODE93, CODE128 EAN128, Industrial 2 to 5, Customer Bar Code, POSTNET, KIX CODE, RM4SCC (ROYAL MAIL 4STATE CUTOMER CODE),
Two-dimensional code		Data Matrix, PDF417, QR Code, Maxi Code, Micro PDF417, CP Code (B-672 only)
Fonts		Times Roman (6 sizes), Helvetica (6 sizes), Presentation (1 size), Letter Gothic (1 size), Prestige Elite (2 sizes), Courier (2 sizes), OCR (2 types), Writable characters (40 types, 2-byte character is available: B682 only), Outline font (B-672: 1 type, B-682: 4 types), Price font (3 types: B-682 only)
Rotations		0°, 90°, 180°, 270°
Standard interfaces		Serial interface (RS-232C) Parallel interface (Centronics) Expansion I/O interface
Optional interface		Flash memory card interface (B-672 only) PCMCIA interface (B-682 only)

* *Data Matrix™* is a trademark of International Data Matrix, Inc.
PDF417 is a trademark of Symbol Technologies, Inc.

2.2 OPTION

Option Name	Type	Description	Source
Cutter module	B-4208-QM	A stop and cut swing cutter	See NOTE 1.
Strip module	B-4908-H-QM	This module strips the label from the backing paper with the take-up block and strip block.	See NOTE 1.
D-RAM PC Board (B-672 only)	FMBC0067801	A 2MB RAM upgrade which enhances the image handling capability of the printer.	See NOTE 2.
Flash memory card (B-672 only)	—————	A flash ROM card (1MB and 4MB) for storing logos, writable characters and formats.	See NOTE 3.
PCMCIA interface board (B-682 only)	B-8700-PC-QM	This board enables the following PCMCIA cards to be used. * LAN card: 3 COM EtherLink®III (recommended) * ATA card: Conforming to PC card ATA standard * Flash memory card: 4MB card (See Page 10-1.)	See NOTE 1.

- NOTES:**
1. Available from your nearest TOSHIBA TEC representative or TOSHIBA TEC Head Quarters.
 2. Available from TOSHIBA TEC Parts Center.
 3. When purchasing flash memory card locally, select one having the specifications described at page 9-1.

2.3 MEDIA

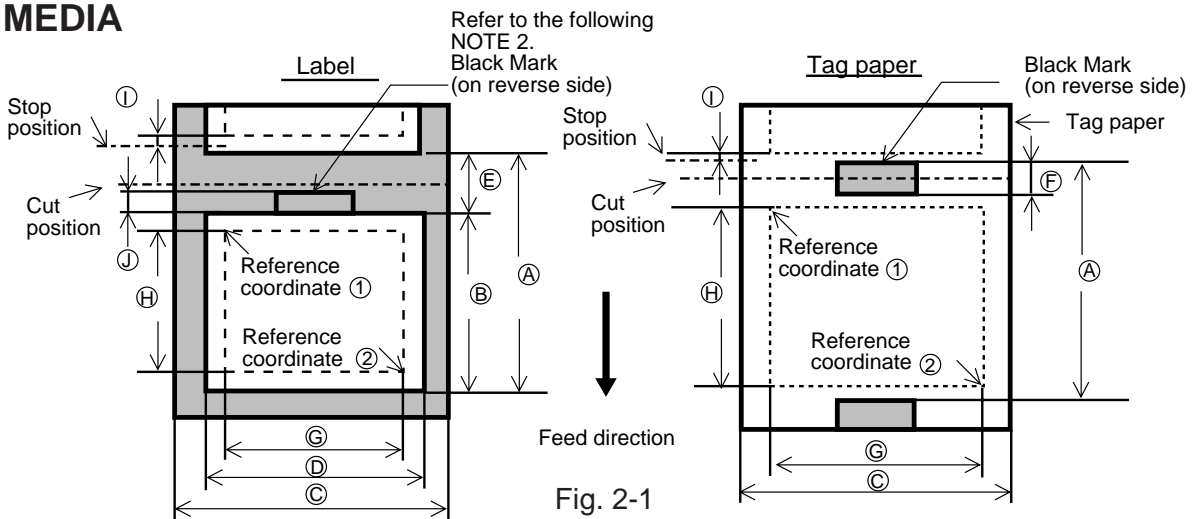

Fig. 2-1

[Unit: mm]

Label dispensing mode		Batch mode	Strip mode	Cut mode		
A: Span of one label/tag	B-672	10.00 ~ 999.0	25.4 ~ 999.0	Label: 38 ~ 999.0 Tag: 25.4 ~ 999.0		
	B-682	10.00 ~ 1709.0	25.4 ~ 1709.0	Label: 38 ~ 1709.0 Tag: 25.4 ~ 1709.0		
B: Label length	B-672	7.5 ~ 996.5	22.9 ~ 996.5	25.0 ~ 993.0		
	B-682	7.5 ~ 1707.0	22.9 ~ 1707.0	25.0 ~ 1703.0		
C: Width including backing paper		84.0 ~ 175.0 (See NOTE 3.)				
D: Label width		81.0 ~ 172.0				
E: Gap length		2.5 ~ 20.0	2.5 ~ 20.0	6.0 ~ 20.0		
F: Black mark length (Tag paper)		2.5 ~ 10.0				
G: Effective print width		10.0 ~ 170.6				
H: Effective print length	Label	Standard	B-672	5.5 ~ 298.6	20.9 ~ 298.6	23.0 ~ 298.6
			B-682	5.5 ~ 1705.0	20.9 ~ 1705.0	23.0 ~ 1705.0
		Max. memory	B-672	5.5 ~ 981.3	20.9 ~ 981.3	23.0 ~ 981.3
	Tag	Standard	B-672	8.0 ~ 298.6	23.4 ~ 298.6	23.4 ~ 298.6
			B-682	8.0 ~ 1705.0	—	23.4 ~ 1705.0
		Max. memory	B-672	8.0 ~ 981.3	23.4 ~ 981.3	23.4 ~ 981.3
I: Print speed up/slow down area		1.0				
J: Black mark length (Label)		Refer to the following NOTE 2.				
Maximum effective length for on the fly issue	Standard	B-672	149.3			
		B-682	852.0			
	Max. memory	B-672	490.6			
Outer roll diameter		Ø200 Max.				
Thickness	Label	0.13 ~ 0.17				
	Tag	0.10 ~ 0.17				

NOTES:

- The media specification other than above are unchanged.
- When marking black marks on label rolls, the following requirements must be satisfied.
When the gap length is less than 4 mm:
The black mark length should be longer than the gap length.
When the gap length is 4 mm or more:
The black mark should not overlap the gap for more than 4 mm and the following label.
- When the print speed is 8"/sec., the width including backing paper will be 84 to 150 mm. When the optional cutter module or strip module is used, the width including backing paper will be 101.6 to 175 mm.
- If the label used is smaller than specified, the print head life may be shortened.
- When issuing thermal labels at 8"/sec., the print stop position should be set to a minimum of 1 mm inside the label.

2.4 RIBBON

Type	Spool type
Width	115 mm ~ 185 mm (See NOTE 5.)
Length	300 m
Outer diameter	Ø72 mm (max.)

NOTES:

- "On the fly issue" means that the printer can draw and print without stopping between labels.
- To ensure print quality and print head life use only TOSHIBA TEC specified media and ribbons.
- When using the cutter ensure that label length B plus inter label gap length E exceeds 35 mm. (i.e. label pitch should be greater than 35 mm.)
- To avoid ribbon wrinkles use the ribbon which is wider than media by 5mm or more. However, too much difference in width between the two may cause wrinkles.
- When the print speed is 8"/sec., the width will be 115 to 160 mm.

3. OVERVIEW

3.1 FRONT/REAR VIEW

Front View

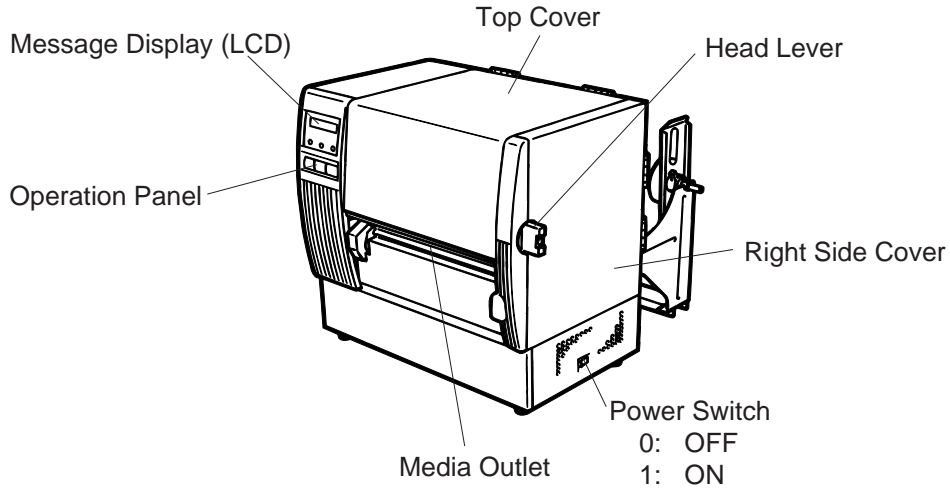

Rear View

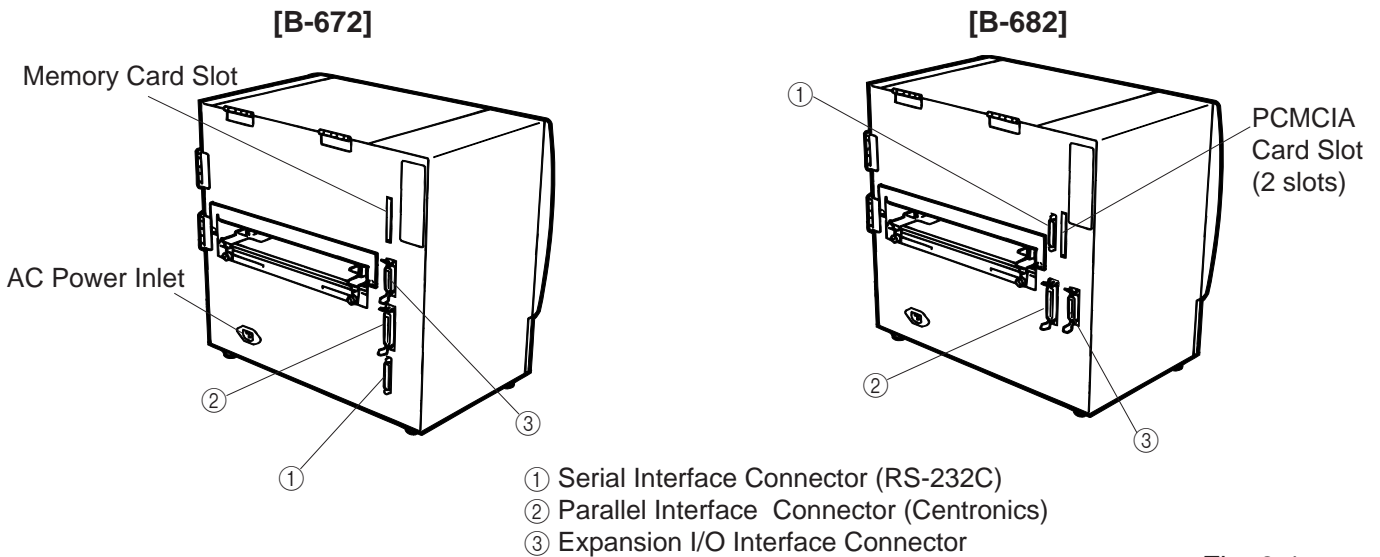

Fig. 3-1

3.2 OPERATION PANEL

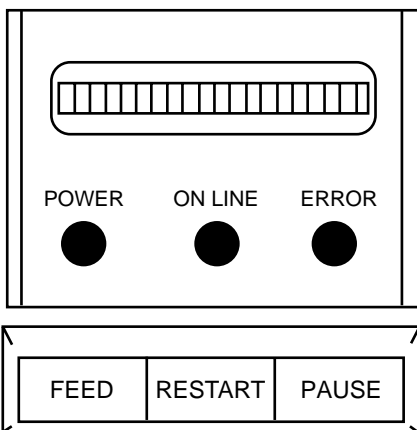

Fig. 3-2

MESSAGE DISPLAY (LCD)

When power is turned on and it is ready to print, "ON LINE" is displayed.

POWER LED (Green)

Lights when the power is turned on.

ON-LINE LED (Green)

- 1) Flashes when communicating with a host computer.
- 2) On while printing.

ERROR LED (Red)

Lights when a communication error occurs, when the media/ribbon ends or the printer does not operate correctly.

FEED Key

Feeds paper.

RESTART Key

Resets the printer when paused or when an error occurs. Used to set the threshold. (Refer to page 12-6)

PAUSE Key

Pauses printing. Message display shows "PAUSE" and an unprinted count. Used to set the threshold. (Refer to page 12-6)

4. DIP SWITCH FUNCTIONS (B-672 only)

The DIP switches are located to the right of the Guide Wheel.

WARNING!
Turn the **POWER OFF** before switching the functions.

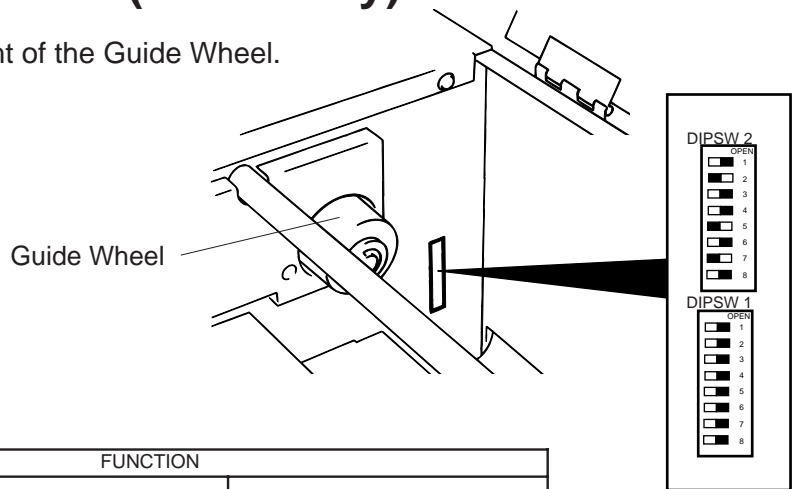

(1) DIP SW 2

No.	ON/OFF		FUNCTION		
	1	2			
1	OFF	OFF	2400 BPS	Transmission speed	
	ON	OFF	4800 BPS		
	OFF	ON	9600 BPS		
	ON	ON	19200 BPS		
3	OFF		1 bit	Stop bit length	
	ON		2 bits		
4	OFF		7 bits	Data length	
	ON		8 bits		
5	OFF		Without	Parity check	
	ON		With		
6	OFF		EVEN	Parity check (effective when DIP SW #5 is set to ON.)	
	ON		ODD		
7		7	8	Data protocol	
	OFF	OFF			XON/XOFF (No XON is output at the power on time.) (No XOFF is output at the power off time.)
	ON	OFF			READY/BUSY (DTA) (No XON is output at the power on time.) (No XOFF is output at the power off time.) READY/BUSY (RTS) (No XON is output at the power on time.) (No OFF is output at the power off time.)
	OFF	ON			XON/XOFF+READY/BUSY (XON is output at the power on time.) (XOFF is output at the power off time.)
8	ON	ON		XON/XOFF (XON is output at the power on time.) (XOFF is output at the power off time.)	

Fig. 4-1

(2) DIP SW 1

No.	ON/OFF			FUNCTION	
	2	3	4		
1	OFF			Must be set to OFF	
	ON				
2	OFF	OFF	OFF	English	
	ON	OFF	OFF	German	
	OFF	ON	OFF	French	
	ON	ON	OFF	Dutch	
3	OFF	OFF	ON	Spanish	
	ON	OFF	ON	Japanese	
	OFF	ON	ON	Italian	
4	ON	ON	ON	Not used	
	OFF			Without	Auto media feed after a cut issue (See page 8-4)
ON			With		
6	OFF			Must be set to OFF	
	ON				
7	OFF			Fixed type	
	ON			Movable type	
8	OFF			Must be set to OFF	
	ON				

NOTES: The Shaded settings are the factory default settings. "OFF" means "OPEN".

5. SET UP PROCEDURE

5.1 REQUIREMENTS FOR OPERATION

The B-672/682 has the following requirements:

- The host computer must have a serial port or centronics parallel port.
- To communicate with host, either an RS-232C cable or Centronics cable is required.
 - (1) RS-232C cable 25 pins
 - (2) Centronics cable 36 pins
- To print the format, create the complete program using the interface/communication manual.

■ Interface Cables

To prevent radiation and reception of electrical noise, the interface cables must meet the following requirements:

- Fully shielded and fitted with metal or metalised connector housings.
- Kept as short as possible.
- Should not be bundled tightly with power cords.
- Should not be tied to power line conduits.

■ RS-232C Cable description

The serial data cable used to connect the printer to the host computer should be one of the following two types:

NOTE: Use an RS-232C cable with imperial (inch) connector securing screws.

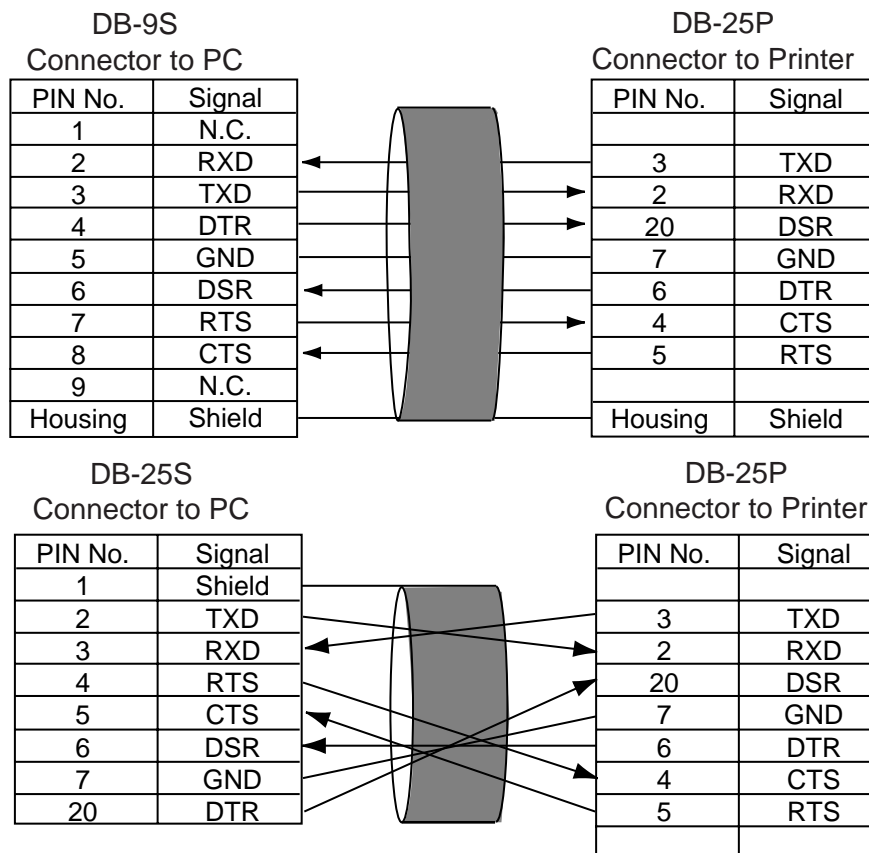

Fig. 5-1

5.2 SETTING UP THE PRINTER

- Place the printer on a flat, stable surface.
- Use a grounded electrical outlet do not use adapter plug.
- Be sure there is adequate room around the printer for easy operation and maintenance.
- Keep your work environment static free.

6. INSTALLATION PROCEDURE

6.1 CONNECTING THE POWER CORD AND CABLES

WARNING!
Turn the **POWER SWITCH** to **OFF** before connecting the power cord or cables.

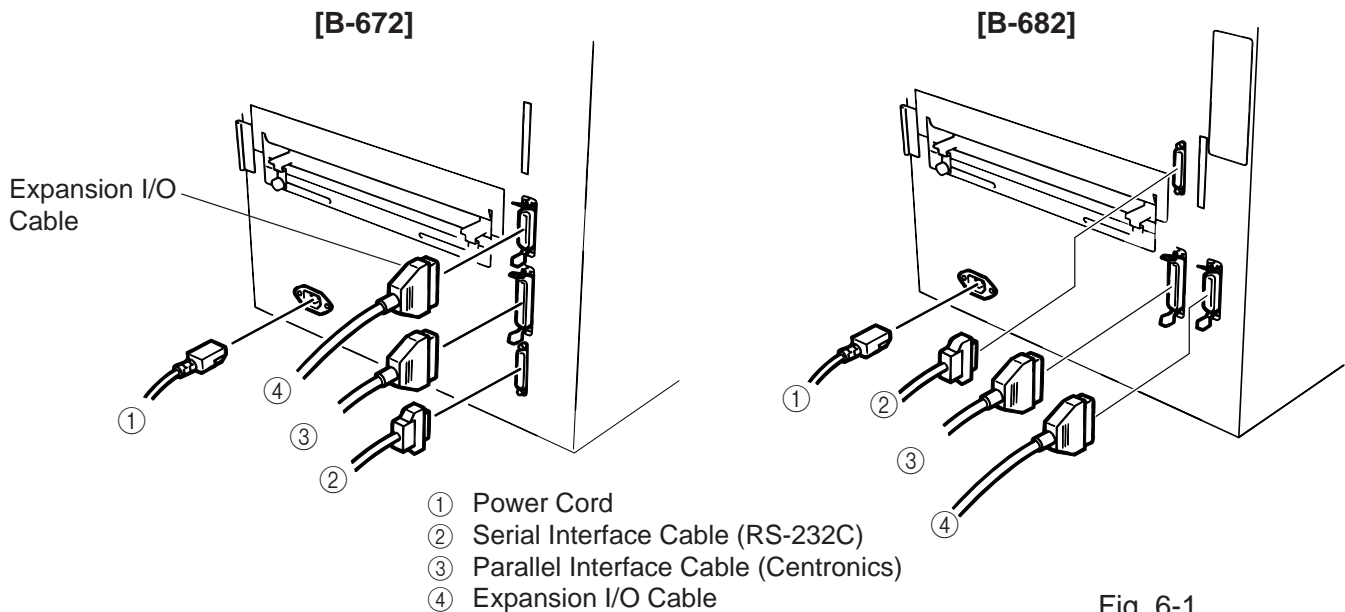

Fig. 6-1

NOTES: Different cables cannot be used at the same time.

6.2 HOLDER STAND INSTALLATION

Fit the left and right side holders into the dowels of the holder base and fasten the side holders to the holder base with the thumbscrews.

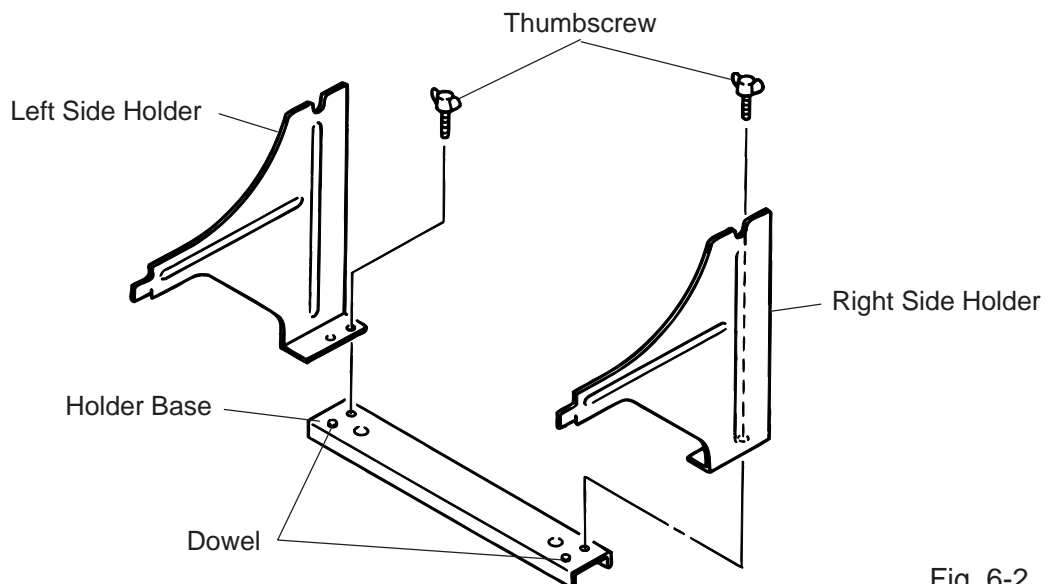

Fig. 6-2

7. LOADING THE RIBBON

WARNING!

1. Do not touch moving parts. To reduce the risk that fingers, jewelry, clothing, etc., be drawn into the moving parts, push the switch in the "OFF" position to stop movement.
2. To avoid injury, be careful not to catch or jam your fingers while opening or closing the cover.

There are two types of media available for printing on, these are standard media and direct thermal media (a chemically treated surface). **DO NOT LOAD** a ribbon when using a direct thermal media.

1. Turn the power off and open both the top cover and the right side cover.
2. Set the head lever to the "OPEN" position and release the head lock plate.

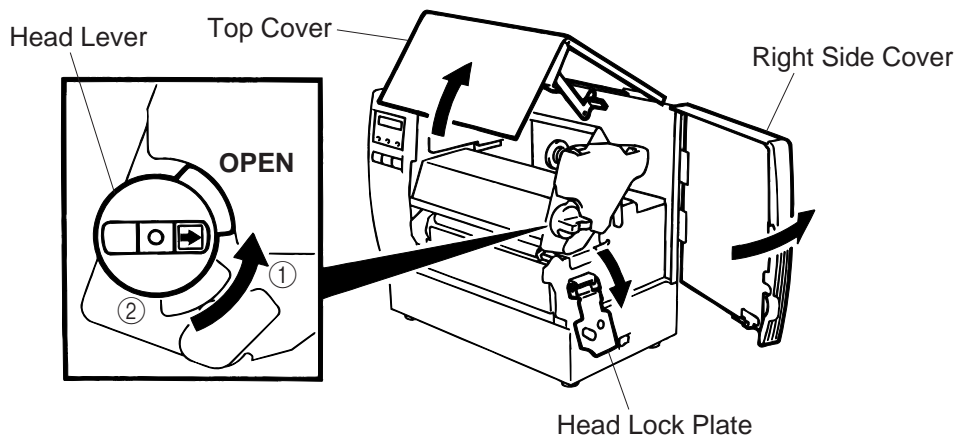

Fig. 7-1

Head Lever Position

- ①: Labels or thin tag paper
- ②: Thick tag paper
- OPEN: Ribbon/media replacement

3. As Fig. 7-2 shows, unroll and loosen the ribbon a little.
4. Insert the ribbon under the print block so that the ribbon supply end is positioned backside of the printer.

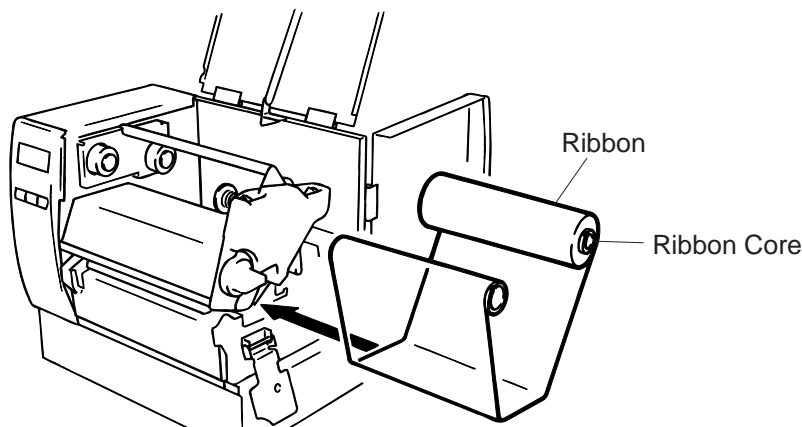

Fig. 7-2

5. Push the ribbon core against the spring guide wheel, align the protrusion of the guide wheel with the notch of the ribbon core, then set the ribbon.
6. To remove the slack of the ribbon, turn the ribbon core in the direction indicated by the arrow.
7. If the ribbon wrinkles while printing, move the ribbon levers back or forth until the wrinkle is removed.

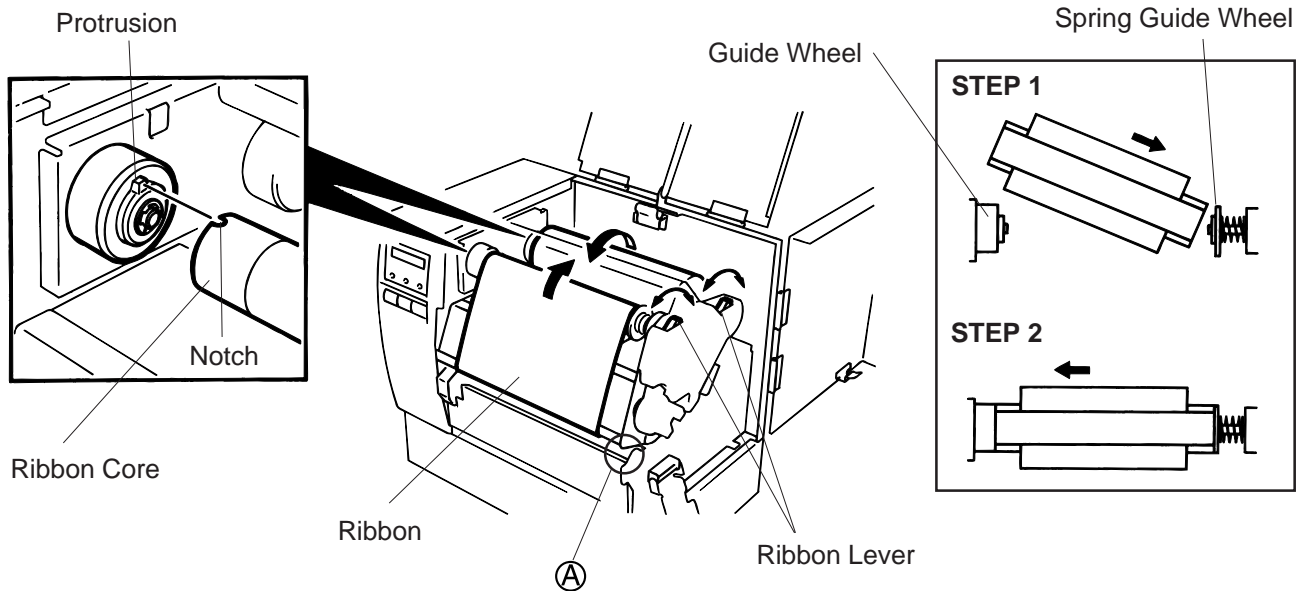

Fig. 7-3

NOTE: When removing the ribbon, be careful not to snag the ribbon on the part ①.

8. Set the head lock plate.
9. Turn the head lever to the proper position depending on the used media. (Refer to Fig. 7-1)
 - ①: Labels or thin tag paper
 - ②: Thick tag paper

CAUTION: When using labels ensure that the head lever is set to position ①.

8. LOADING THE MEDIA

WARNING!

1. Do not touch moving parts. To reduce the risk that fingers, jewelry, clothing, etc., be drawn into the moving parts, push the switch in the "OFF" position to stop movement.
2. To avoid injury, be careful not to catch or jam your fingers while opening or closing the cover.

1. Install the holder stand on the rear of the printer.
2. Loosen the screw (A) and slide the media guides outside.

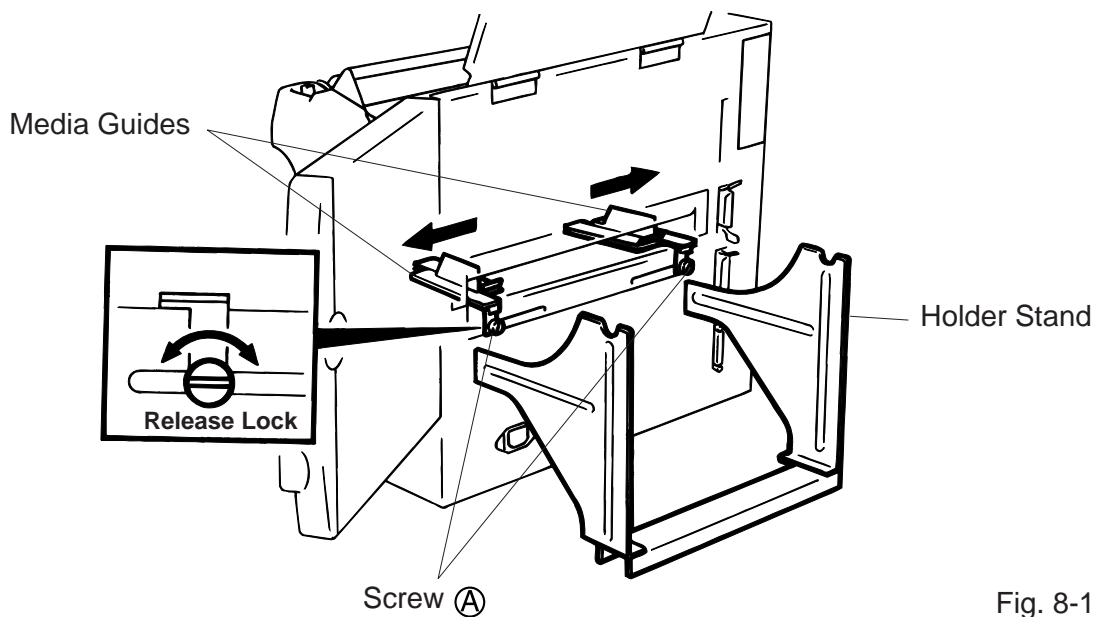

Fig. 8-1

CAUTION:

DO NOT MOVE the Media Guides using the screw (A).

3. Lock the Media Holder securely with the Lock Lever.
4. Pass the Holder Shaft through the Media, then set one of the Media Holders and lock it securely with the Lock Lever.

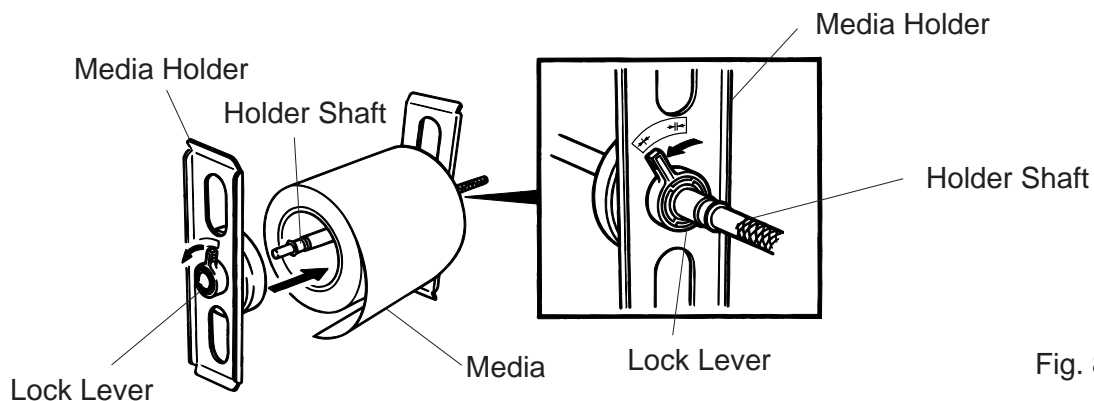

Fig. 8-2

5. Turn the Lock Levers of the Media Holders to the unlock position and readjust the Media position to the center. Then lock the Media Holders securely with the Lock Levers. Fit the Media Guides to the Media. Tighten the screw (A) firmly.

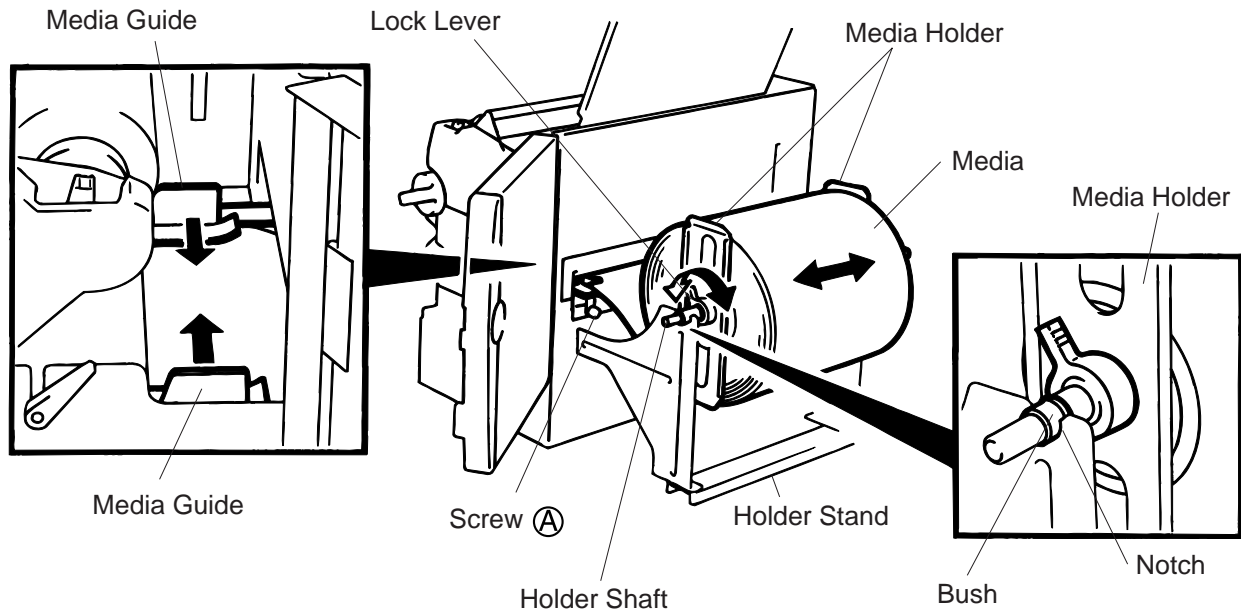

Fig. 8-3

NOTE: Set in the bushes of the Holder Shaft into notches of the Holder Stand securely.

6. The black mark/feed gap sensor is selectable between the fixed type and the movable type by changing the DIP switch setting on the B-672. For the B-682, contact your authorized TOSHIBA TEC representative to change the Operation Panel setting. When the fixed type is selected, the black mark sensor is located at the center of the media and the feed gap sensor is at 10 mm left to the black mark sensor. The movable sensor can be located anywhere between the left end of the effective print width and the fixed sensor. After changing the sensor type, the sensitivity of the sensor must be adjusted. In this case call a TOSHIBA TEC authorized service representative.

7. Set the black mark/feed gap sensor to the correct position by turning the adjusting knob. Turning the knob right will move the sensor towards the center of the media while turning left will move it away from the center of the media.

■ An easy way to set the black mark sensor position

- ① Pull the media about 500 mm out of the front of the printer, turn the media back on it's self and feed it under the print head past the sensor so that the black mark can be seen from above.
- ② Adjust the sensor position to that of the black mark (the upper hole indicates the position of the black mark sensor).

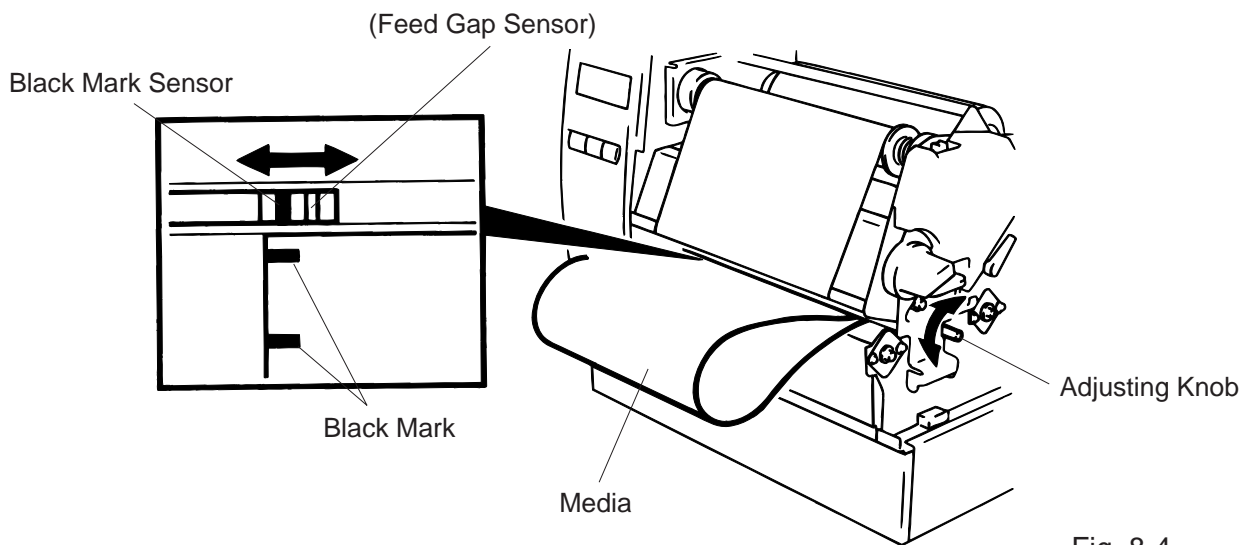

Fig. 8-4

NOTE: Make sure to set the sensor to detect the center of the black mark, otherwise a paper jam error could occur.

■ Setting the feed gap sensor position

Adjust the sensor to detect on the gap (the lower hole indicates the position of the feed gap sensor).

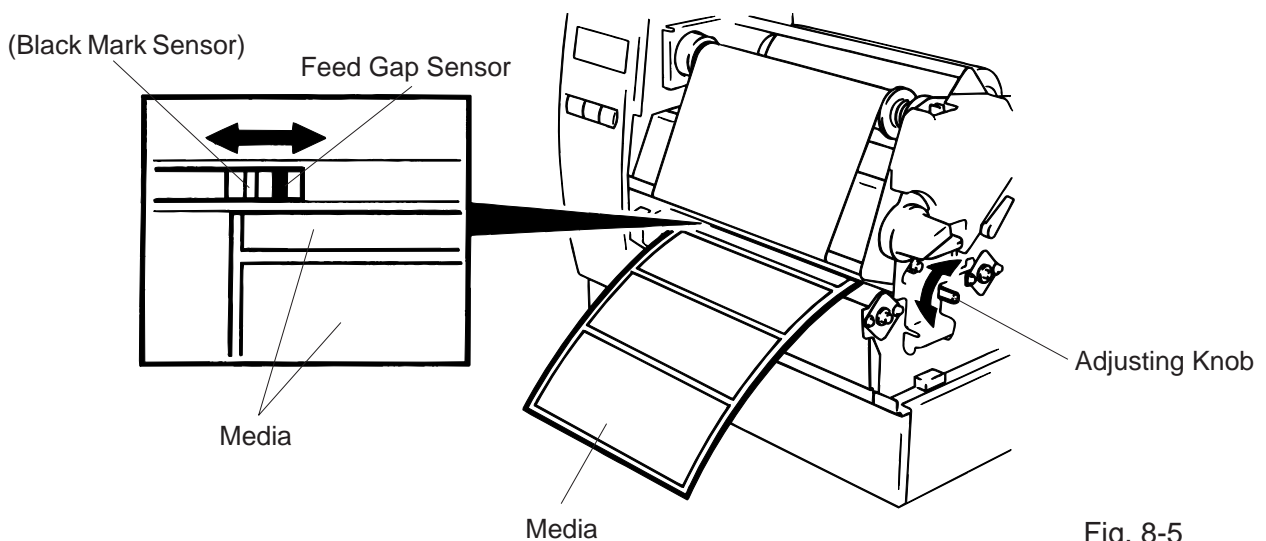

Fig. 8-5

8. The media is now loaded and the sensor position is set.

Batch type:

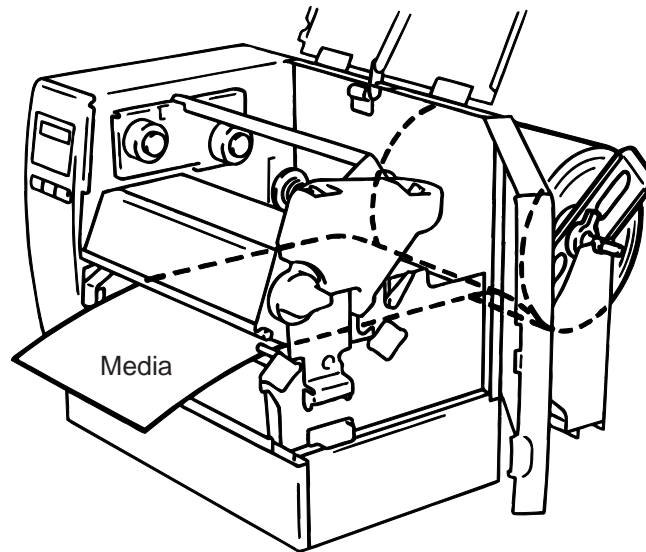

Fig. 8-6

Cutter type: Where a cutter is fitted load the media as standard and feed it through the cutter module.

- NOTES:**
1. Be sure to cut the backing paper of label. Cutting label will cause the glue to stick to the cutter, which may affect the cutter quality and shorten the cutter life.
 2. If the top edge of label winds onto the platen in cut issue, set the DIP SW 1-5 of the B-672 to ON. For the B-682, contact your authorized TOSHIBA TEC representative to change the Operation Panel setting.
 3. Use of tag paper with the thickness exceeding the specified value may affect the cutter life.

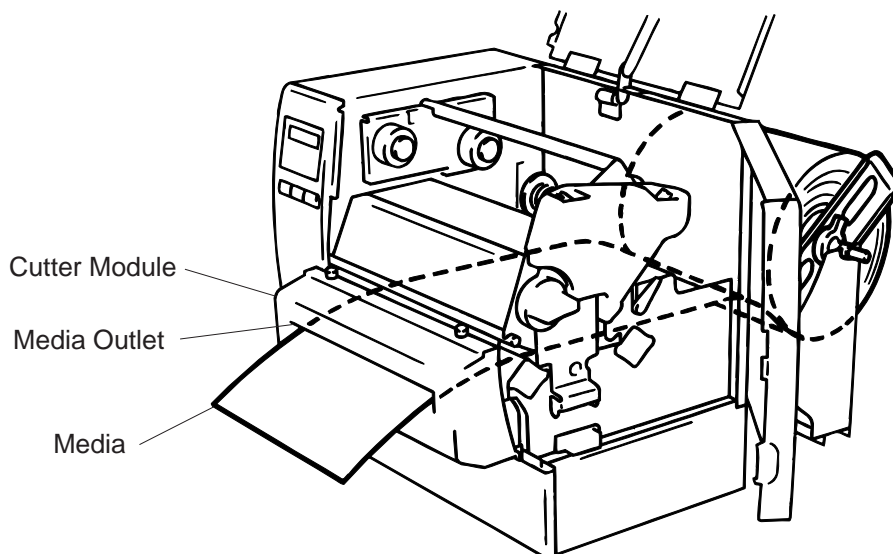

Fig. 8-7

Strip type:

- ① Strip labels from the backing paper for about 200-mm long from the top edge of the label roll.
- ② Lower the backing paper release bar.
- ③ Pass the backing paper between the strip roller and the backing paper holder. After taking up any slack of the media, set the backing paper release bar in position.

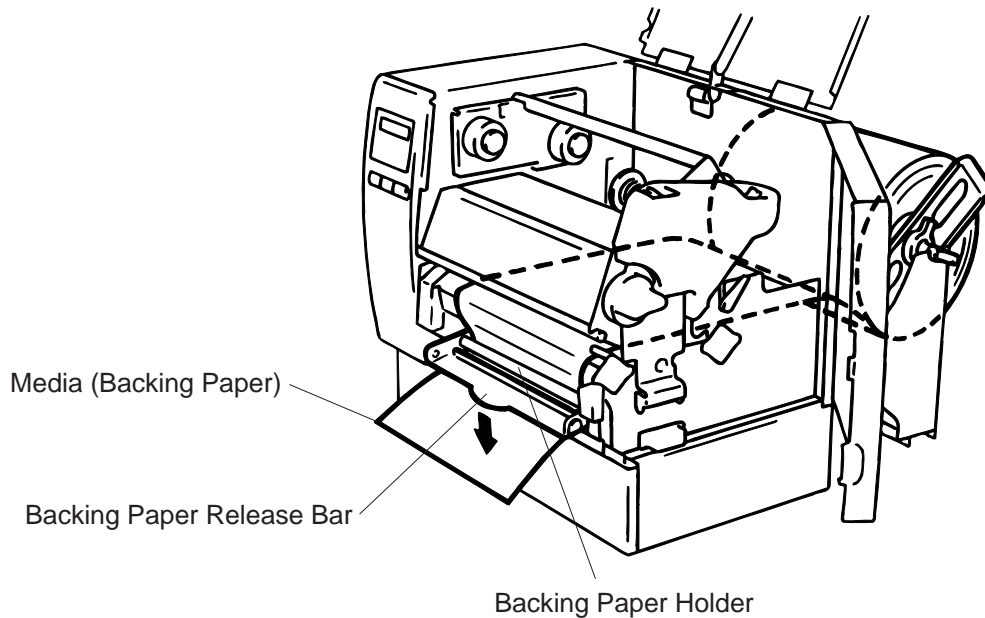

Fig. 8-8

9. Turn the head lever to the proper position depending on the used media. (Refer to Fig. 7-1)
 - ①: Labels or thin tag paper
 - ②: Thick tag paper

CAUTION: When using labels ensure that the head lever is set to position ①.

10. Close the top and right side covers.

9. INSERTING THE OPTIONAL FLASH MEMORY CARD (B-672 only)

WARNING!

Turn the power OFF when inserting or removing the flash memory card.

CAUTION:

To protect memory cards, discharge static electricity from your body by touching the printer rear cover prior to touching the memory cards.

1. Turn the power off.
2. Insert the flash memory card into the memory card slot on the rear of the printer.
3. Turn the power on.

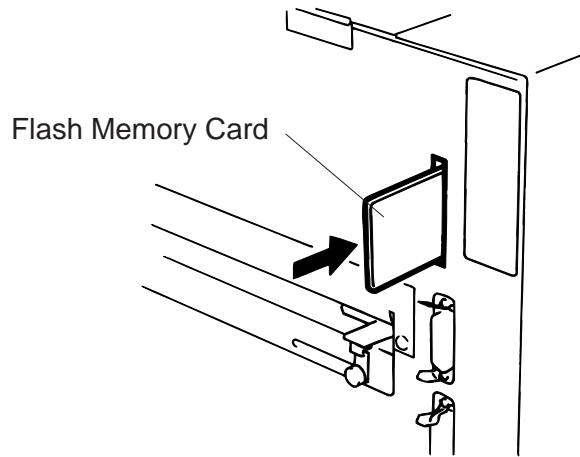

Fig. 9-1

- NOTES:**
1. Be sure to protect a flash memory card when not in use in the printer by putting it in its protective cover.
 2. Do not subject the card to any shocks or excessive forces.
 3. Do not expose the card to extremes of heat by either storing in direct sunlight or close to a heater.
 4. Do not expose the card to excessive humidity by wiping it with a wet cloth or storing it in a damp place.
 5. Before inserting or removing the card, make sure that the power switch is turned off.
 6. The following flash cards can be used. (The 1MB-card is read only and the 4MB card can read/write.)

Capacity	Maker	Type	Device code	Maker code
1M Byte	Maxell	EF-1M-TB [AA]	D0H	1CH
	Mitsubishi	MF81M1-GBDAT01		
4M Byte	Maxell	EF-4M-TB [CC]	88H	B0H
	Maxell	EF-4M-TB [DC]	ADH	04H
	Centennial Technologies INC.	FL04M-15-11119-03		01H
	INTEL	IMC004FLSA	A2H	89H
	Simple TECHNOLOGY	STI-FL/4A		
	Mitsubishi	MF84M1-G7DAT01		
	PC Card KING MAX	FJN-004M6C		
	Centennial Technologies INC.	FL04M-20-11138-67		
	PC Card	FJP-004M6R	A0H	89H
	Mitsubishi	MF84M1-GMCAV01	AAH	

10. INSERTING THE OPTIONAL PCMCIA CARD (B-682 only)

WARNING:

Turn the power OFF when inserting or removing the PCMCIA card.

CAUTION:

To protect PCMCIA cards, discharge static electricity from your body by touching the printer rear cover prior touching the PCMCIA cards.

1. Turn the power off.
2. Insert the PCMCIA card into the card slot at the rear of the printer.
3. Turn the power on.

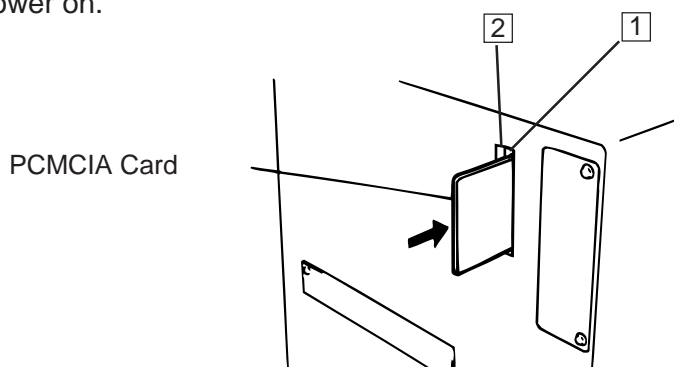

Fig. 10-1

- NOTES:**
1. Be sure to protect a PCMCIA card when not in use in the printer by putting it in its protective cover.
 2. Do not subject the card to any shocks or excessive forces.
 3. Do not expose the card to extremes of heat by either storing in direct sunlight or close to a heater.
 4. Do not expose the card to excessive humidity by wiping it with a wet cloth or storing it in a damp place.
 5. Before inserting or removing the card, make sure that the power switch is turned off.
 6. The following PCMCIA cards can be used.

Type	Maker	Description	Remarks
ATA Card		A card conforming to the PC card ATA standard	_____
LAN Card	3 COM	Ether Link III 3C589D PC card	Install into the slot (2) only. (This card installed into the slot (1) will not work.)
Flash Memory Card (4 MB)	Maxell	EF-4M-TB <input type="checkbox"/> CC	_____
		EF-4M-TB <input type="checkbox"/> DC	

7. Install the LAN card into the slot (2).

11. CARE/HANDLING OF THE MEDIA AND RIBBON

CAUTION:

Be sure to read carefully and understand the Supply Manual. Use only media and ribbon which meet specified requirements. Use of non-specified media and ribbon may shorten the head life and result in problems with bar code readability or print quality. All media and ribbon should be handled with care to avoid any damage to the media, ribbon or printer. Read the following guideline carefully.

- Do not store the media and ribbon for longer than the manufactures recommended shelf life.
- Store media rolls on the flat end, do not store them on the curved sides as this might flatten that side causing erratic media advance and poor print quality.
- Store the media in plastic bags and always reseal after opening. Unprotected media can get dirty and the extra abrasion from the dust and dirt particles will shorten the print head life.
- Store the media and ribbon in a cool, dry place. Avoid areas where they would be exposed to direct sunlight, high temperature, high humidity, dust or gas.
- The thermal paper used for direct thermal printing must not have the specifications which exceed Na⁺ 800 ppm, K⁺ 250 ppm and CL⁻ 500 ppm.
- Some ink used on pre-printed labels may contain ingredients which shorten the print head's product life. Do not use labels pre-printed with ink which contain hard substances such as carbonic calcium (CaCO₃) and kaolin (Al₂O₃, 2SiO₂, 2H₂O).

For further information please contact your local distributor or your media and ribbon manufacturer.

12. GENERAL MAINTENANCE

WARNING!

1. Be careful when handling the print head as it becomes very hot.
2. Care must be taken not to injure yourself with the printer paper cutter.
3. Do not touch moving parts. To reduce the risk that fingers, jewelry, clothing, etc., be drawn into the moving parts, push the switch in the "OFF" position to stop movement.
4. To avoid injury, be careful not to catch or jam your fingers while opening or closing the cover.

12.1 CLEANING

WARNING!

1. Be sure to disconnect the power cord prior to performing any maintenance.
2. Do not use any tool that may damage the print head.
3. **DO NOT POUR WATER** directly onto the printer.

To help retain the high quality and performance of your printer it should be regularly cleaned. The greater the usage of the printer, the more frequent the cleaning. (i.e. low usage=weekly : high usage=daily).

1. Turn the power off.
2. Open the top cover and right side cover.
3. Turn the head lever to raise the print head.
4. Remove the ribbon and media.
5. Clean the element of print head with print head cleaner.
6. Clean the platen with an alcohol moistened cloth.

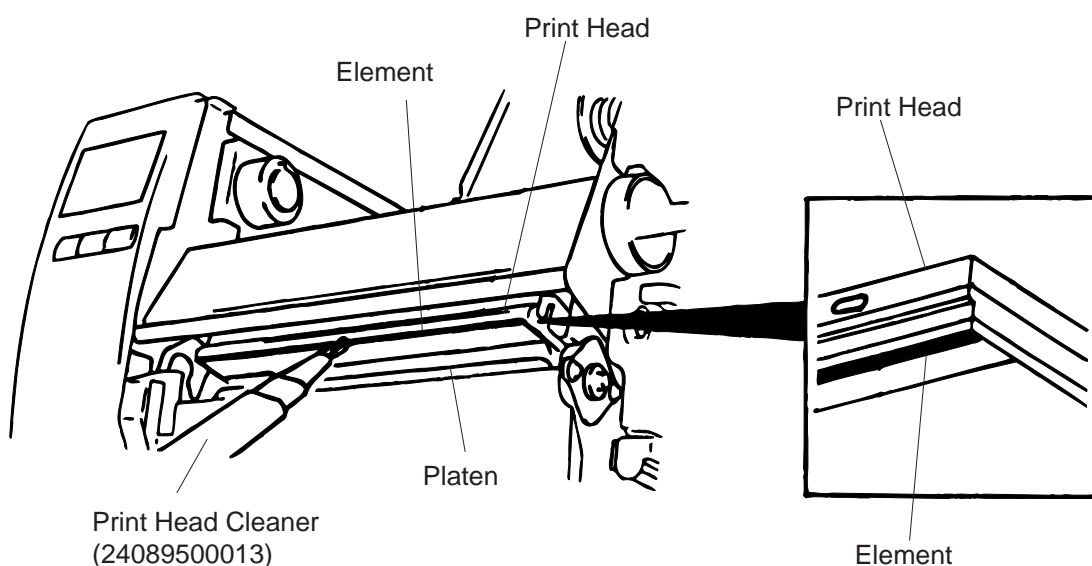

Fig. 12-1

7. Turn the pinch roller lever to the right.
8. Remove the white screw and detach the ribbon end sensor plate.

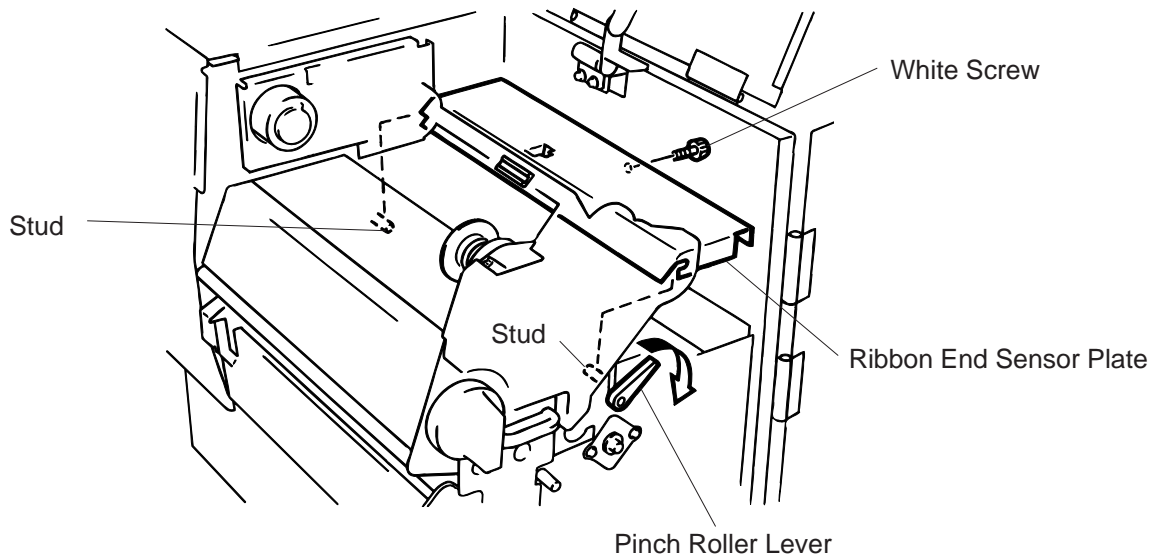

Fig. 12-2

NOTE: When installing the ribbon end sensor plate, be sure to fit both studs in the notches of the ribbon end sensor plate.

9. Remove the pinch roller block, then clean the roller belt and feed roller with cloth moistened by alcohol.

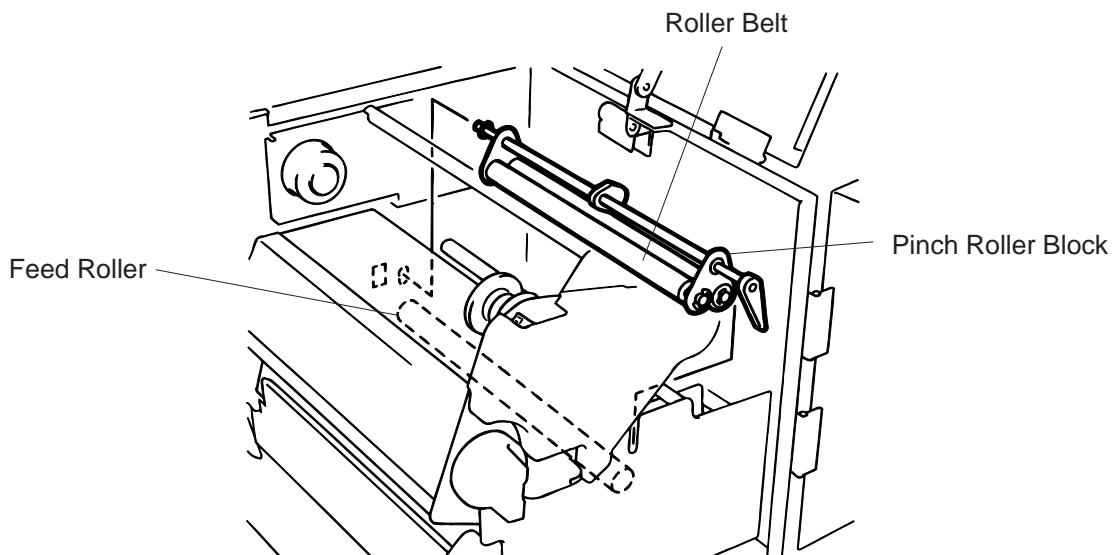

Fig. 12-3

10. Reassemble the pinch roller block in the reverse order of removal.

12.2 UNDER THE MEDIA GUIDES

1. Remove the Media Guides.

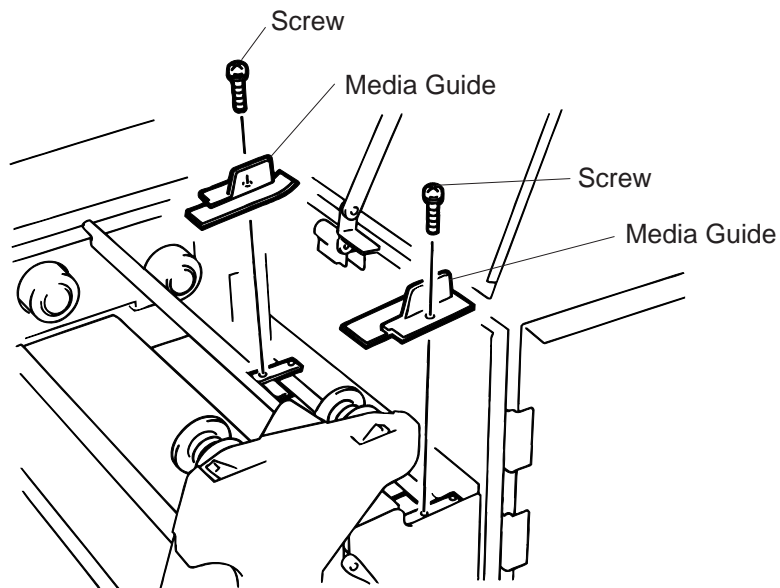

Fig. 12-4

2. Remove the jammed Media.
3. Clean "dust and glue" on the Media Guides with a soft cloth moistened with alcohol.
4. Remount the Media guides using the screws.

NOTE: Be careful **NOT TO LOSE** the screw.

12.3 COVERS AND PANELS

The covers should be cleaned by wiping with a dry cloth or a cloth slightly dampened with a mild detergent solution.

NOTE: Clean printer cover with an electrostatic free cleaner for automated office equipment.

WARNING!

1. **DO NOT POUR WATER** directly onto the printer.
2. **DO NOT APPLY** cleaner or detergent directly onto any cover or panel.
3. **NEVER USE THINNER OR OTHER VOLATILE SOLVENT** on the plastic covers.
4. **DO NOT** clean the panel covers or the supply window with alcohol as it may cause them to discolor, loose their shape or develop structural weakness.

12.4 REMOVING JAMMED MEDIA

1. Turn the power off.
2. Open the top cover, and right side cover.
3. Turn the head lever to position "OPEN," then release the head lock plate.
4. Remove the white screw, unclamp and disconnect the connector of the media guide plate, and then detach the media guide plate. (See Fig. 12-5.)
5. Remove the ribbon and media.
6. Remove the jammed media. **DO NOT USE** any sharp implement or tool as these could damage the printer.
7. Clean the print head and platen, then remove any further dust or foreign substances.
8. Place the portion ② of the media guide plate on the media sensor. Secure the media guide plate with the white screw.

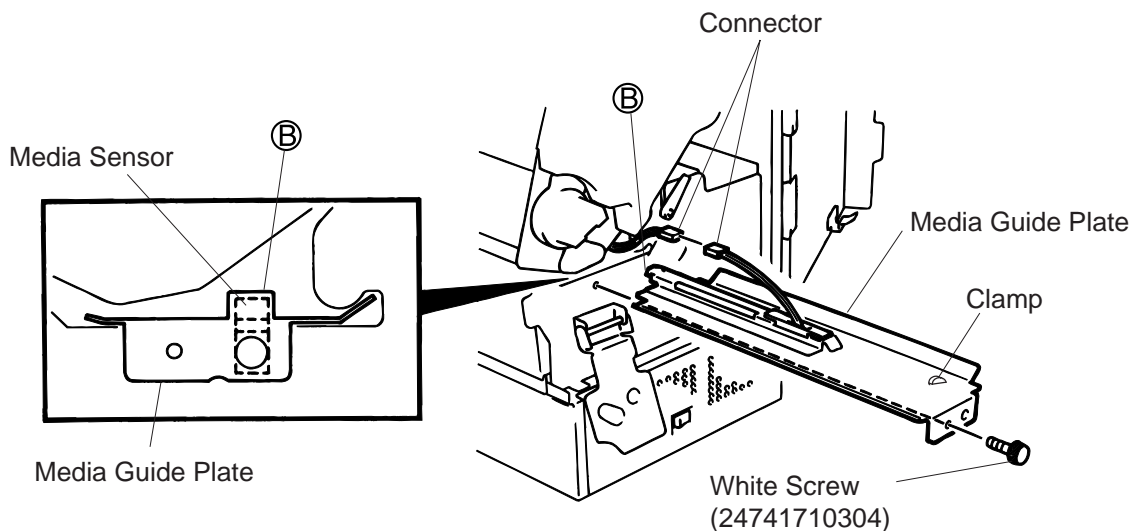

Fig. 12-5

9. Media jams in the cutter unit can be caused by wear or residual glue from label stock on the cutter. Do not use none specified media in the cutter. If you get frequent jams in the cutter contact your Authorized Service representative.

■ Cleaning the Cutter Unit

WARNING!

1. Be sure to turn the power off before cleaning the cutter unit.
2. The cutters are sharp and care should be taken not to injure yourself when cleaning.

1. Loosen two screws and remove the cutter cover.
2. Remove the white screw and media guide.
3. Remove the jammed paper and trash.
4. Clean the cutter with dry cloth.

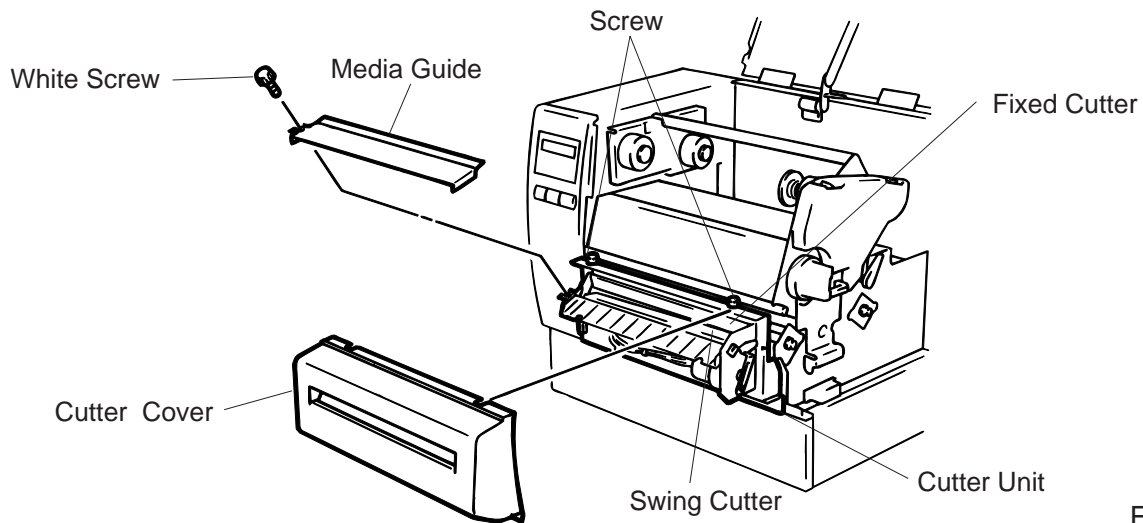

Fig. 12-7

5. Assembling is reverse order of removal.

■ Cleaning the strip unit

WARNING!

Be sure to turn the power off before cleaning the strip unit.

1. Lower the backing paper release bar to remove the jammed media.
2. Clean the strip roller and backing paper holder with ethyl alcohol.

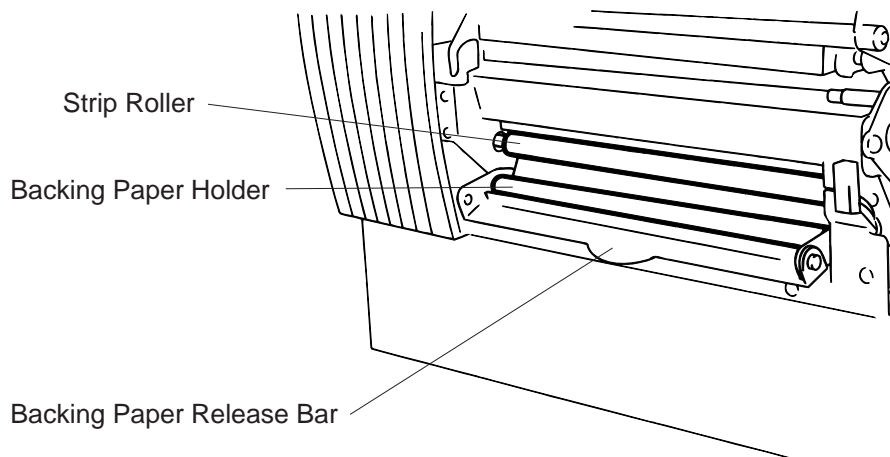
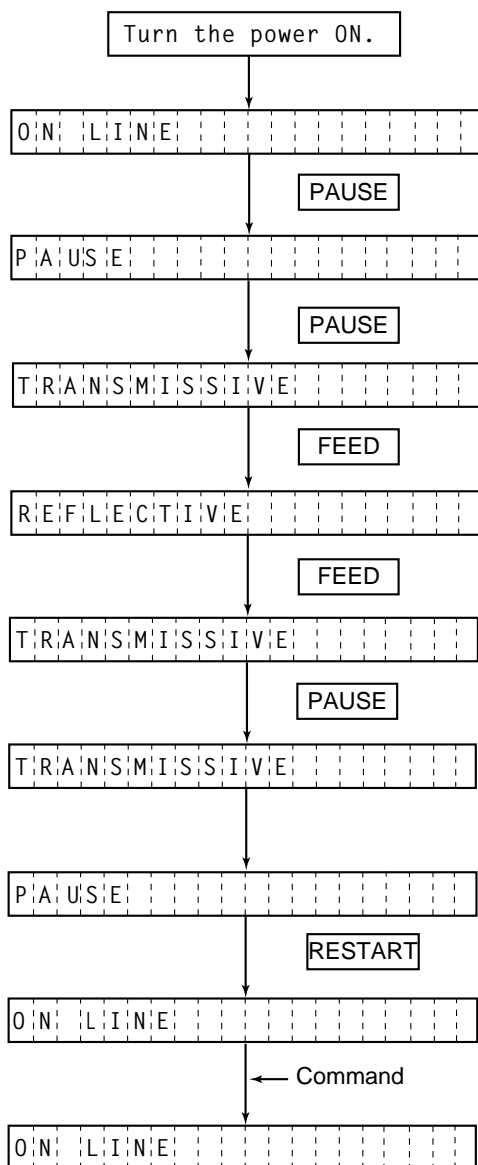

Fig. 12-8

12.5 THRESHOLD SETTING

For the printer to maintain a constant print position it uses the transmissive sensor to detect the gap between labels by measuring the amount of light passing through the media. When the media is pre-printed, the darker (or more dense) inks can interfere with this process causing paper jam errors. To get around this problem a minimum threshold can be set for the sensor in the following way.

■ Threshold setting procedure



- (1) The printer is in stand-by.
- (2) Load a media roll in the usual way.
- (3) Press the **[PAUSE]** key.
- (4) The printer enters the pause mode.
- (5) Press and hold the **[PAUSE]** key for at least 3 seconds in the pause state.
- (6) The sensor type is displayed.
- (7) Press the **[FEED]** key.
- (8) The reflective sensor (black mark sensor) is selected.
- (9) Press the **[FEED]** key again.
- (10) The transmissive sensor (feed gap sensor) is selected.
- (11) Press and hold the **[PAUSE]** key.
- (12) The media is advanced until the **[PAUSE]** key is released.
- (13) Release the **[PAUSE]** key when more than 1.5 labels (tags) are advanced.
(Threshold setting is completed by this operation.)
- (14) Press the **[RESTART]** key.
- (15) The printer is in stand-by.
- (16) Send an issue command from the PC to the printer.

NOTES:

1. If the **[PAUSE]** key is released within 3 seconds whilst in pause state, paper will not feed.
2. Failure to feed more than 1.5 to 2 labels may result in an incorrect threshold setting.
3. While the print head is raised, the **[PAUSE]** key does not work.
4. Error such as paper end and cutter error are not detected during paper feed.
5. Selecting the transmissive sensor (for pre-printed labels) within software commands allows the printer to detect the proper print start position correctly even when using pre-printed labels.
6. If the printer continues to print out of position after setting the threshold, adjust the feed gap sensor in the system mode. Reset the threshold again. Make sure that the transmissive sensor (for pre-printed labels) is selected in the feed and issue commands.

13. TROUBLESHOOTING

WARNING!

If you cannot solve a problem with the following solutions, do not attempt to repair it yourself. Turn the power off, unplug the printer, then contact your TOSHIBA TEC representative for assistance.

Error Message	Problem	Solution
PAPER JAM ****	<ol style="list-style-type: none"> The media is not fitted correctly. The media path is jammed and does not feed smoothly. The installed media type does not match the selected sensor. The black mark position on the media does not match the sensor position. The installed media size is different from the programmed size. The feed gap sensor cannot see the difference between the print area and the gap. 	<ol style="list-style-type: none"> Re-fit the media correctly. → Press the RESTART key. Remove the cause of the jam and replace the media correctly. → Press the RESTART key. Turn the power off then on again. Select the correct sensor. → Feed the media. Adjust the sensor position. → Press the RESTART key. Turn the power off then on again. Set the correct media size. → Feed the media. Set the threshold (see page 12-6). Else Turn the power off and call your Authorized Service representative.
HEAD OPEN ****	Feed or printing has been attempted while the print head is raised or the pinch roller lever is depressed.	Lower the print head or raise the pinch roller lever. → Press the RESTART key.
NO PAPER ****	The media has run out.	Load new media. → Press the RESTART key.
NO RIBBON ****	The ribbon has run out.	Load a new ribbon. → Press the RESTART key.

Error Message	Problem	Solution
EXCESS HEAD TEMP.	The print head is too hot.	Turn the power off and decrease the print head temperature.
HEAD ERROR	This message is displayed when sending the head broken check command ([ESC] HD001 [LF] [NUL]) and the print head has a broken element.	<ol style="list-style-type: none"> Restart the printing by pressing the RESTART key. Replace the print head.
RIBBON ERROR ****	There is a fault with the ribbon sensor.	Turn the power off. Contact your Authorized Service representative.
CUTTER ERROR ****	Media is jammed in the cutter.	<p>Remove the jammed media and feed the undamaged media through the cutter.</p> <p>→ Press the RESTART key.</p> <p>Else Turn the power off and contact your Authorized Service representative.</p>
FLASH WRITE ERROR	An error has occurred when loading data onto a flash memory card or ATA card.	<ol style="list-style-type: none"> Turn the power off, re-seat the flash memory card or ATA card and try again. Replace the flash memory card or ATA card and retry. Turn the power off and contact your Authorized Service representative.
FORMAT ERROR	An error has occurred while formatting a flash memory card or ATA card.	<ol style="list-style-type: none"> Turn the power off, re-seat the flash memory card or ATA card and try again. Replace the flash memory card or ATA card and retry. Turn the power off and contact your Authorized Service representative.
FLASH MEMORY FULL	No more data can be saved in the flash memory card or ATA card.	<p>Replace the card with a new one and re-send data.</p> <p>(In case of flash memory card, only 1MB and 4MB cards can be used. B-682: 4 MB only)</p>
COMMUNICATION ERROR	A communication error has occurred with the host.	<p>Turn the power off then on again or press the RESTART key.</p> <p>Check the program data.</p> <p>→ Call your Authorized Service representative if necessary.</p>

Error Message	Problem	Solution
example) PC001;0A00, ↑ Command error 0300, 2, 2	When an error is detected in a command 20 bytes of the command are displayed. (ESC, LF, NUL are not displayed.)	Correct the command and re-send it again.
Other Error Message	Hardware or software trouble.	Turn the power off then on again. If the problem still exists turn the power off and contact your Authorized Service representative.
<p>NOTE: If an error is not cleared by pressing the RESTART key, the power must be switched off then on again. After the power has been switched off and on, all print data in the printer is cleared. **** denotes a remaining count of unprinted labels.</p>		

Problem	Solution
No print.	<ol style="list-style-type: none"> 1. Check that the media and the ribbon is loaded correctly. 2. Check whether the print head is set correctly or not. 3. Check the cabling between the printer and the host.
Dots missing in the print.	Dirty print head. → Clean the print head. Call your Authorized Service representative if necessary.
Unclear (or blurred) printing.	<ol style="list-style-type: none"> 1. Dirty print head. → Clean the print head. 2. Bad or faulty ribbon. → Replace ribbon. 3. Poor media quality. → Change media type.
Power does not come on.	<ol style="list-style-type: none"> 1. Plug power cord into an AC socket. 2. Check the circuit breakers or fuses. 3. Plug another appliance into the AC socket to check if there is power supplied. Call your Authorized Service representative if necessary.
Printer does not cut.	Check for a paper jam in the cutter. Call your Authorized Service representative if necessary.
You see a raised nap where the media has been cut.	<ol style="list-style-type: none"> 1. Clean the cutter blades. 2. The blades are worn. → Call your Authorized Service representative.

