

PCI-DAS1002

Multifunction Analog and Digital I/O

User's Guide

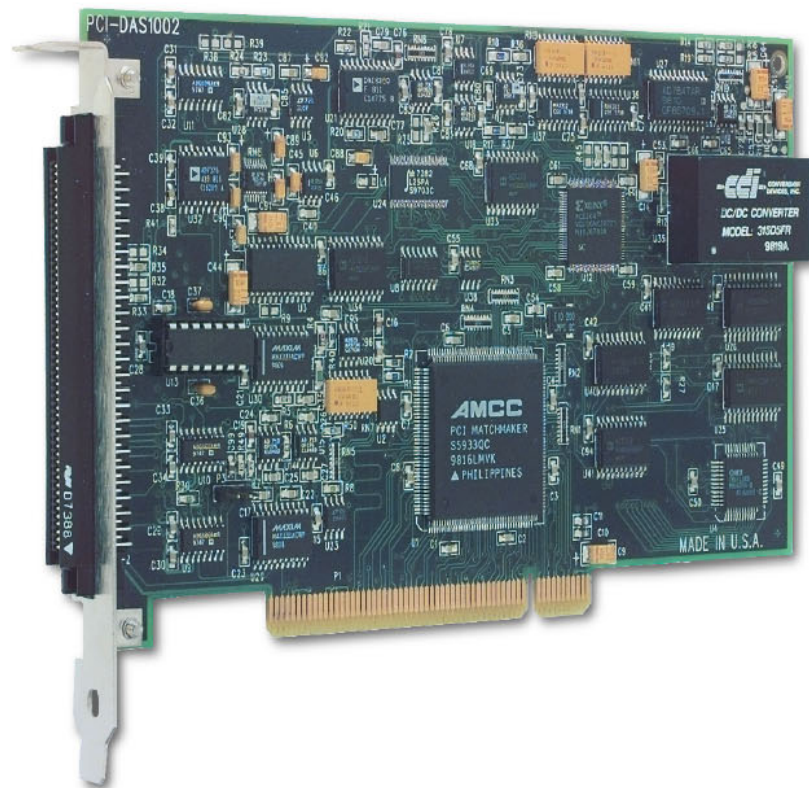

PCI-DAS1002

Multifunction Analog & Digital I/O

User's Guide



**MEASUREMENT
COMPUTING™**

Document Revision 4, July, 2007

© Copyright 2007, Measurement Computing Corporation

Your new Measurement Computing product comes with a fantastic extra —

Management committed to your satisfaction!

Refer to www.mccdaq.com/execteam.html for the names, titles, and contact information of each key executive at Measurement Computing.

Thank you for choosing a Measurement Computing product—and congratulations! You own the finest, and you can now enjoy the protection of the most comprehensive warranties and unmatched phone tech support. It's the embodiment of our mission:

- To provide PC-based data acquisition hardware and software that will save time and save money.

Simple installations minimize the time between setting up your system and actually making measurements. We offer quick and simple access to outstanding live FREE technical support to help integrate MCC products into a DAQ system.

Lifetime warranty: Every hardware product manufactured by Measurement Computing Corporation is warranted against defects in materials or workmanship for the life of the product. Products found defective are repaired or replaced promptly.

Lifetime Harsh Environment Warranty®: We will replace any product manufactured by Measurement Computing Corporation that is damaged (even due to misuse) for only 50% of the current list price. I/O boards face some tough operating conditions, some more severe than the boards are designed to withstand. When a board becomes damaged, just return the unit with an order for its replacement at only 50% of the current list price. We don't need to profit from your misfortune. By the way, we honor this warranty for any manufacturer's board that we have a replacement for.

30 Day Money Back Guarantee: You may return any Measurement Computing Corporation product within 30 days of purchase for a full refund of the price paid for the product being returned. If you are not satisfied, or chose the wrong product by mistake, you do not have to keep it. Please call for an RMA number first. No credits or returns accepted without a copy of the original invoice. Some software products are subject to a repackaging fee.

These warranties are in lieu of all other warranties, expressed or implied, including any implied warranty of merchantability or fitness for a particular application. The remedies provided herein are the buyer's sole and exclusive remedies. Neither Measurement Computing Corporation, nor its employees shall be liable for any direct or indirect, special, incidental or consequential damage arising from the use of its products, even if Measurement Computing Corporation has been notified in advance of the possibility of such damages.

Trademark and Copyright Information

TracerDAQ, Universal Library, Harsh Environment Warranty, Measurement Computing Corporation, and the Measurement Computing logo are either trademarks or registered trademarks of Measurement Computing Corporation.

Windows, Microsoft, and Visual Studio are either trademarks or registered trademarks of Microsoft Corporation

LabVIEW is a trademark of National Instruments.

CompactFlash is a registered trademark of SanDisk Corporation.

XBee and XBee-PRO are trademarks of MaxStream, Inc.

All other trademarks are the property of their respective owners.

Information furnished by Measurement Computing Corporation is believed to be accurate and reliable. However, no responsibility is assumed by Measurement Computing Corporation neither for its use; nor for any infringements of patents or other rights of third parties, which may result from its use. No license is granted by implication or otherwise under any patent or copyrights of Measurement Computing Corporation.

All rights reserved. No part of this publication may be reproduced, stored in a retrieval system, or transmitted, in any form by any means, electronic, mechanical, by photocopying, recording, or otherwise without the prior written permission of Measurement Computing Corporation.

Notice

Measurement Computing Corporation does not authorize any Measurement Computing Corporation product for use in life support systems and/or devices without prior written consent from Measurement Computing Corporation. Life support devices/systems are devices or systems which, a) are intended for surgical implantation into the body, or b) support or sustain life and whose failure to perform can be reasonably expected to result in injury. Measurement Computing Corporation products are not designed with the components required, and are not subject to the testing required to ensure a level of reliability suitable for the treatment and diagnosis of people.

Table of Contents

Preface	
About this User's Guide	7
What you will learn from this user's guide	7
Conventions in this user's guide	7
Where to find more information	7
Chapter 1	
Introducing the PCI-DAS1002	8
Overview: PCI-DAS1002 features	8
Software features	8
PCI-DAS1002 block diagram	9
Chapter 2	
Installing the PCI-DAS1002	10
What is included with your PCI-DAS1002	10
Hardware	10
Additional documentation	10
Optional components	10
Unpacking the PCI-DAS1002	11
Installing the software	11
Installing the hardware	11
Configuring the hardware	12
Differential input mode	12
Single-ended input mode	12
Connecting the board for I/O operations	12
Connectors, cables – main I/O connector	12
Pinout – main I/O connector	13
Cables	15
Field wiring and signal termination	15
Chapter 3	
Programming and Developing Applications	16
Programming languages	16
Packaged applications programs	16
Register-level programming	16
Chapter 4	
Calibrating the Board	17
Introduction	17
Calibration theory	17
Chapter 5	
Specifications	18
Analog input	18
Accuracy	19
Crosstalk	19
Noise performance	19
Analog output	20
Absolute accuracy	20
Calibrated accuracy components	20
Counters	21
Digital input/output	22
Interrupts	22

Miscellaneous	22
Power consumption	22
Environmental	22
Mechanical	22
Connector and pin out.....	23
8-channel differential mode pin out	23
16-channel single-ended mode pin out.....	24
Declaration of Conformity	25

About this User's Guide

What you will learn from this user's guide

This user's guide explains how to install, configure, and use the PCI-DAS1002 so that you get the most out of its analog, digital, and timing I/O features.

This user's guide also refers you to related documents available on our web site, and to technical support resources.

Conventions in this user's guide

For more information on ...

Text presented in a box signifies additional information and helpful hints related to the subject matter you are reading.

Caution! Shaded caution statements present information to help you avoid injuring yourself and others, damaging your hardware, or losing your data.

<#:#> Angle brackets that enclose numbers separated by a colon signify a range of numbers, such as those assigned to registers, bit settings, etc.

bold text **Bold** text is used for the names of objects on the screen, such as buttons, text boxes, and check boxes. For example:

1. Insert the disk or CD and click the **OK** button.

italic text *Italic* text is used for the names of manuals and help topic titles, and to emphasize a word or phrase. For example:

The *InstaCal*® installation procedure is explained in the *Quick Start Guide*.
Never touch the exposed pins or circuit connections on the board.

Where to find more information

The following electronic documents provide relevant information to the operation of your PCI-DAS1002.

- MCC's *Specifications: PCI-DAS1002* (the PDF version of the Electrical Specification Chapter in this guide) is available on our web site at www.mccdaq.com/pdfs/PCI-DAS1002.pdf.
- MCC's *Quick Start Guide* is available on our web site at www.mccdaq.com/PDFmanuals/DAQ-Software-Quick-Start.pdf.
- MCC's *Guide to Signal Connections* is available on our web site at www.mccdaq.com/signals/signals.pdf.
- MCC's *Universal Library User's Guide* is available on our web site at www.mccdaq.com/PDFmanuals/sm-ul-user-guide.pdf.
- MCC's *Universal Library Function Reference* is available on our web site at www.mccdaq.com/PDFmanuals/sm-ul-functions.pdf.
- MCC's *Universal Library for LabVIEW™ User's Guide* is available on our web site at www.mccdaq.com/PDFmanuals/SM-UL-LabVIEW.pdf.

PCI-DAS1002 User's Manual (this document) is also available on our web site at www.mccdaq.com/PDFmanuals/PCI-DAS1002.pdf.

Introducing the PCI-DAS1002

Overview: PCI-DAS1002 features

This manual explains how to install and use the PCI-DAS1002. This board is a multifunction analog and digital I/O board designed for the PCI bus.

The PCI-DAS1002 provides either 16 single-ended or eight differential analog inputs. Input ranges are software-selectable as either bipolar or unipolar.

Analog input ranges for the PCI-DAS1002 are software programmable for the following ranges:

- Bipolar: ± 10 V, ± 5 V, ± 2.5 V, and ± 1.25 V
- Unipolar: 0 to 10 V, 0 to 5 V, 0 to 2.5 V and 0 to 1.25 V

The PCI-DAS1002 provides a 200 kHz sample rate.

The PCI-DAS1002 also provides two channels of 12-bit analog output. Analog output ranges are ± 10 V and ± 5 V (bipolar) and 0-10 V, 0-5 V (unipolar).

The PCI-DAS1002 offers 24-bits of parallel, digital I/O (two 8-bit ports and two 4-bit ports). You can configure each port independently as input or output.

This board has an 82C54 counter chip which has three user-accessible 16-bit counters. Clock, gate, and output signals from two of three counters are available on a 100-pin connector. The third counter is used internally.

The PCI-DAS1002 is fully plug-and-play. All addresses and interrupt channels are set with software.

Software features

For information on the features of *InstaCal* and the other software included with your PCI-DAS1002, refer to the *Quick Start Guide* that shipped with your device. The *Quick Start Guide* is also available in PDF at www.mccdaq.com/PDFmanuals/DAQ-Software-Quick-Start.pdf.

Check www.mccdaq.com/download.htm for the latest software version.

PCI-DAS1002 block diagram

PCI-DAS1002 functions are illustrated in the block diagram shown here.

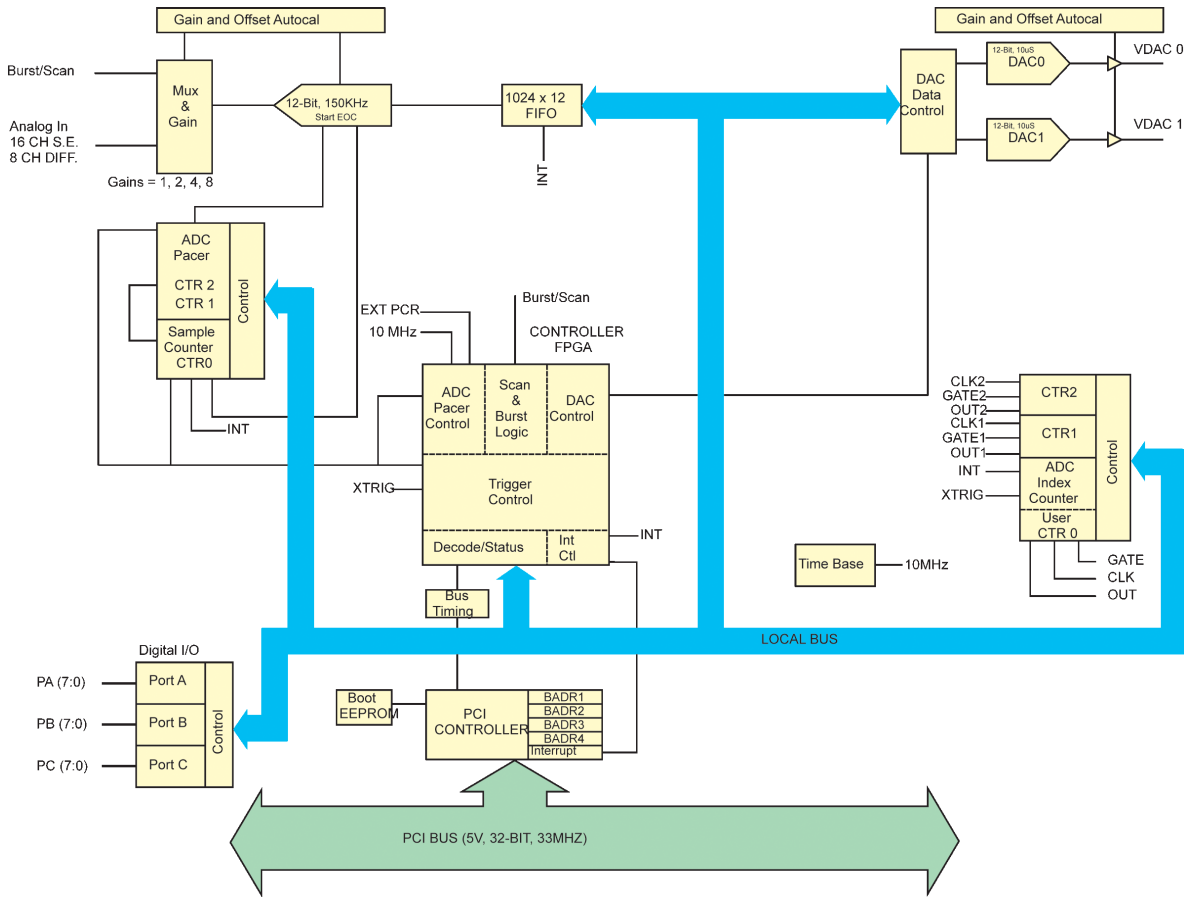

Figure 1. PCI-DAS1002 functional block diagram

Installing the PCI-DAS1002

What is included with your PCI-DAS1002

As you unpack your board, make sure each of the items shown below is included:

Hardware

- PCI-DAS1002

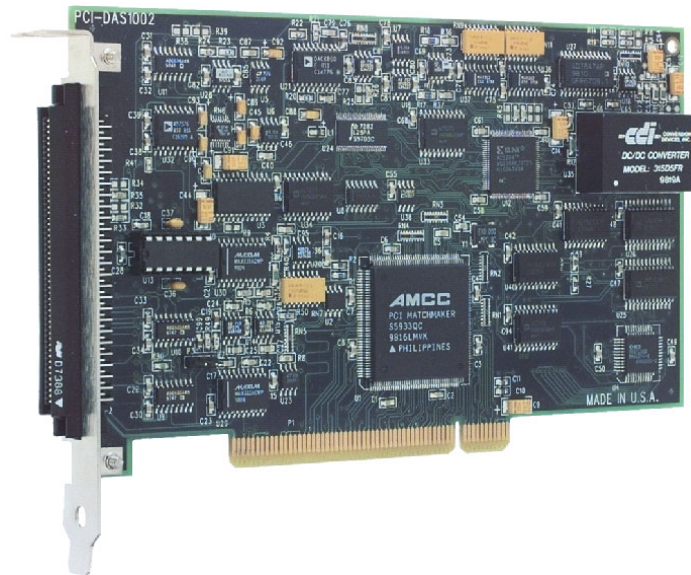

Additional documentation

In addition to this hardware user's guide, you should also receive the *Quick Start Guide* (available in PDF at www.mcdaq.com/PDFmanuals/DAQ-Software-Quick-Start.pdf). This booklet supplies a brief description of the software you received with your PCI-DAS1002 and information regarding installation of that software. Please read this booklet completely before installing any software or hardware.

Optional components

If you ordered any of the following products with your board, they should be included with your shipment.

- C100FF-x cable

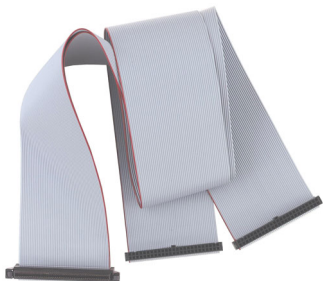

- Signal termination and conditioning accessories
MCC provides signal termination and conditioning products for use with the PCI-DAS1002. Refer to the "[Field wiring and signal termination](#)" section for a complete list of compatible accessory products.

Unpacking the PCI-DAS1002

As with any electronic device, you should take care while handling to avoid damage from static electricity. Before removing the PCI-DAS1002 from its packaging, ground yourself using a wrist strap or by simply touching the computer chassis or other grounded object to eliminate any stored static charge.

If any components are missing or damaged, notify Measurement Computing Corporation immediately by phone, fax, or e-mail:

- Phone: 508-946-5100 and follow the instructions for reaching Tech Support.
- Fax: 508-946-9500 to the attention of Tech Support
- Email: techsupport@mccdaq.com

Installing the software

Refer to the *Quick Start Guide* for instructions on installing the software on the *Measurement Computing Data Acquisition Software CD*. This booklet is available in PDF at www.mccdaq.com/PDFmanuals/DAQ-Software-Quick-Start.pdf.

Installing the hardware

The PCI-DAS1002 board is completely plug-and-play. There are no switches or jumpers to set on the board. Configuration is controlled by your system's BIOS. To install your board, follow the steps below.

Install the MCC DAQ software before you install your board

The driver needed to run your board is installed with the MCC DAQ software. Therefore, you need to install the MCC DAQ software before you install your board. Refer to the *Quick Start Guide* for instructions on installing the software.

1. Turn your computer off, open it up, and insert your board into an available PCI slot.
2. Close your computer and turn it on.

If you are using an operating system with support for plug-and-play (such as Windows 2000 or Windows XP), a dialog box opens as the system loads, indicating that new hardware has been detected. The information file for this board should have already been loaded onto your PC when you installed the *Measurement Computing Data Acquisition Software CD* supplied with your board, and should be detected automatically by Windows. If you have not installed this software, cancel the dialog and install it now.

3. To test your installation and configure your board, run the *InstaCal* utility installed in the previous section. Refer to the *Quick Start Guide* that came with your board for information on how to initially set up and load *InstaCal*.

Allow your computer to warm up for at least 15 minutes before acquiring data with this board. The high speed components used on the board generates heat, and it takes this amount of time for a board to reach steady state if it has been powered off for a significant amount of time.

Configuring the hardware

All hardware configuration options on the PCI-DAS1002 are software controlled. You can select some of the configuration options using *InstaCal*, such as the analog input configuration (16 single-ended or eight differential channels), and the source for the two independent counters. Once selected, any program that uses the Universal Library will initialize the hardware according to these selections.

For general information regarding analog signal connection and configuration, refer to the *Guide to Signal Connections* (available on our web site at www.mccdaq.com/signals/signals.pdf).

Differential input mode

When all channels are configured for differential input mode, eight analog input channels are available. In this mode, the input signal is measured with respect to the low input. The input signal is delivered through three wires:

- The wire carrying the signal to be measured connects to CH# IN HI.
- The wire carrying the reference signal connects to CH# IN LO.
- The third wire, typically a system ground, connects to LLGND.

Single-ended input mode

When all channels are configured for single-ended input mode, 16 analog input channels are available. In this mode, the input signal is referenced to the board's signal ground (LLGND). The input signal is delivered through two wires:

- The wire carrying the signal to be measured connects to CH# IN HI.
- The second wire connects to LLGND.

Connecting the board for I/O operations

Connectors, cables – main I/O connector

The table below lists the board connectors, applicable cables, and compatible accessory boards for the PCI-DAS1002.

Board Connectors, cables, accessory equipment

Connector type	100 pin high density Robinson Nugent connector
Compatible cables	C100FF-x, unshielded ribbon cable. x = length in feet (Figure 2 on page 15)
Compatible accessory products (with the C100FF-x cable)	ISO-RACK16/P ISO-DA02/P CIO-ERB08 (DADP-5037 adaptor required *) CIO-ERB24 (DADP-5037 adaptor required *) SSR-RACK08 (DADP-5037 adaptor required *) SSR-RACK24 (DADP-5037 adaptor required *) BNC-16SE BNC-16DI CIO-MINI50 (2 required) CIO-TERM100 (1 required) SCB-50 (1 required)
* Details on the DADP-5037 adaptor board are available on our web site at www.mccdaq.com/cbicatalog/cbiproduct.asp?dept_id=103&pf_id=1381 .	

Pinout – main I/O connector

8-channel differential mode

Signal Name	Pin		Pin	Signal Name
GND	100	••	50	GND
N/C	99	••	49	N/C
N/C	98	••	48	PC +5V
N/C	97	••	47	N/C
N/C	96	••	46	N/C
A/D Int. Pacer Output	95	••	45	A/D External Trigger
N/C	94	••	44	N/C
N/C	93	••	43	N/C
PC -12V	92	••	42	A/D External Pacer
PC GND	91	••	41	CTR4 OUT
PC +12V	90	••	40	CTR4 GATE
PC GND	89	••	39	CTR4 CLK
N/C	88	••	38	D/A OUT 1
CTR5 OUT	87	••	37	D/A GND 1
CTR5 GATE	86	••	36	D/A OUT 0
CTR5 CLK	85	••	35	D/A GND 0
N/C	84	••	34	N/C
N/C	83	••	33	N/C
CTR6 OUT	82	••	32	N/C
CTR6 GATE	81	••	31	N/C
CTR6 CLK	80	••	30	N/C
N/C	79	••	29	N/C
N/C	78	••	28	N/C
N/C	77	••	27	N/C
N/C	76	••	26	N/C
N/C	75	••	25	N/C
FIRSTPORTC Bit 7	74	••	24	N/C
FIRSTPORTC Bit 6	73	••	23	N/C
FIRSTPORTC Bit 5	72	••	22	N/C
FIRSTPORTC Bit 4	71	••	21	N/C
FIRSTPORTC Bit 3	70	••	20	N/C
FIRSTPORTC Bit 2	69	••	19	N/C
FIRSTPORTC Bit 1	68	••	18	LLGND
FIRSTPORTC Bit 0	67	••	17	CH7 IN LO
FIRSTPORTB Bit 7	66	••	16	CH7 IN HI
FIRSTPORTB Bit 6	65	••	15	CH6 IN LO
FIRSTPORTB Bit 5	64	••	14	CH6 IN HI
FIRSTPORTB Bit 4	63	••	13	CH5 IN LO
FIRSTPORTB Bit 3	62	••	12	CH5 IN HI
FIRSTPORTB Bit 2	61	••	11	CH4 IN LO
FIRSTPORTB Bit 1	60	••	10	CH4 IN HI
FIRSTPORTB Bit 0	59	••	9	CH3 IN LO
FIRSTPORTA Bit 7	58	••	8	CH3 IN HI
FIRSTPORTA Bit 6	57	••	7	CH2 IN LO
FIRSTPORTA Bit 5	56	••	6	CH2 IN HI
FIRSTPORTA Bit 4	55	••	5	CH1 IN LO
FIRSTPORTA Bit 3	54	••	4	CH1 IN HI
FIRSTPORTA Bit 2	53	••	3	CH0 IN LO
FIRSTPORTA Bit 1	52	••	2	CH0 IN HI
FIRSTPORTA Bit 0	51	••	1	LLGND
PCI slot ↓				

16-channel single-ended mode

Signal Name	Pin		Pin	Signal Name
GND	100	••	50	GND
N/C	99	••	49	N/C
N/C	98	••	48	PC +5V
N/C	97	••	47	N/C
N/C	96	••	46	N/C
A/D Int. Pacer Output	95	••	45	A/D External Trigger In
N/C	94	••	44	N/C
N/C	93	••	43	N/C
PC -12V	92	••	42	A/D External Pacer
PC GND	91	••	41	CTR4 OUT
PC +12V	90	••	40	CTR4 GATE
PC GND	89	••	39	CTR4 CLK
N/C	88	••	38	D/A OUT 1
CTR5 OUT	87	••	37	D/A GND 1
CTR5 GATE	86	••	36	D/A OUT 0
CTR5 CLK	85	••	35	D/A GND 0
N/C	84	••	34	N/C
N/C	83	••	33	N/C
CTR6 OUT	82	••	32	N/C
CTR6 GATE	81	••	31	N/C
CTR6 CLK	80	••	30	N/C
N/C	79	••	29	N/C
N/C	78	••	28	N/C
N/C	77	••	27	N/C
N/C	76	••	26	N/C
N/C	75	••	25	N/C
FIRSTPORTC Bit 7	74	••	24	N/C
FIRSTPORTC Bit 6	73	••	23	N/C
FIRSTPORTC Bit 5	72	••	22	N/C
FIRSTPORTC Bit 4	71	••	21	N/C
FIRSTPORTC Bit 3	70	••	20	N/C
FIRSTPORTC Bit 2	69	••	19	N/C
FIRSTPORTC Bit 1	68	••	18	LLGND
FIRSTPORTC Bit 0	67	••	17	CH15 IN
FIRSTPORTB Bit 7	66	••	16	CH7 IN
FIRSTPORTB Bit 6	65	••	15	CH14 IN
FIRSTPORTB Bit 5	64	••	14	CH6 IN
FIRSTPORTB Bit 4	63	••	13	CH13 IN
FIRSTPORTB Bit 3	62	••	12	CH5 IN
FIRSTPORTB Bit 2	61	••	11	CH12 IN
FIRSTPORTB Bit 1	60	••	10	CH4 IN
FIRSTPORTB Bit 0	59	••	9	CH11 IN
FIRSTPORTA Bit 7	58	••	8	CH3 IN
FIRSTPORTA Bit 6	57	••	7	CH10 IN
FIRSTPORTA Bit 5	56	••	6	CH2 IN
FIRSTPORTA Bit 4	55	••	5	CH9 IN
FIRSTPORTA Bit 3	54	••	4	CH1 IN
FIRSTPORTA Bit 2	53	••	3	CH8 IN
FIRSTPORTA Bit 1	52	••	2	CH0 IN
FIRSTPORTA Bit 0	51	••	1	LLGND
PCI slot ↓				

Cables

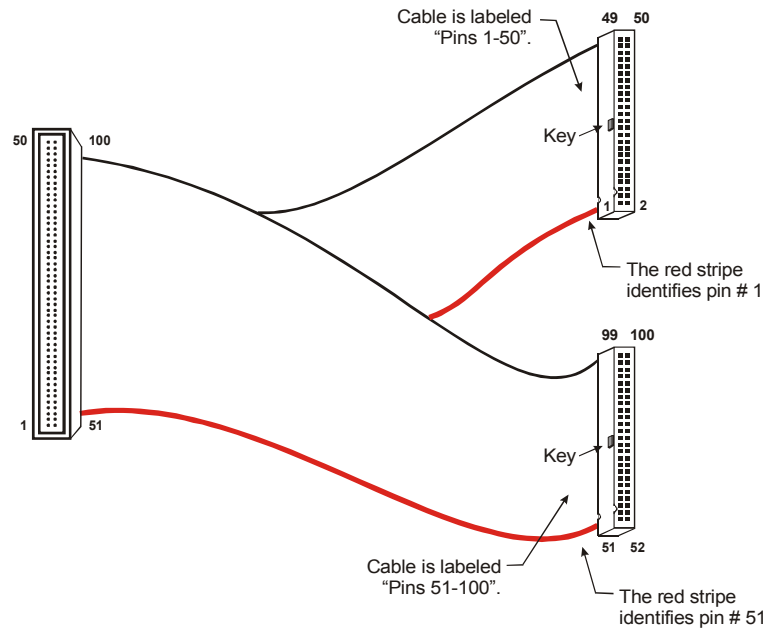

Figure 2. C100FF-x cable

Field wiring and signal termination

The following MCC screw terminal and signal conditioning boards are compatible with the PCI-DAS1002:

- **SCB-50** – 50-conductor, shielded signal connection box. Details on this product are available on our web site at www.mccdaq.com/cbicatalog/cbiproduct.asp?dept_id=196&pf_id=1168.
- **CIO-MINI50** – 50-pin universal screw terminal accessory. Details on this product are available on our web site at www.mccdaq.com/cbicatalog/cbiproduct.asp?dept_id=102&pf_id=258.
- **ISO-RACK16/P** – 16-channel isolation module mounting rack. Details on this product are available on our web site at www.mccdaq.com/cbicatalog/cbiproduct.asp?dept_id=127&pf_id=1111.
- **ISO-DA02/P** – Two-channel 5B module rack. Details on this product are available on our web site at www.mccdaq.com/cbicatalog/cbiproduct.asp?dept_id=128&pf_id=710.
- **BNC-16SE** – 16-channel single-ended BNC connector box. Details on this product are available on our web site at www.mccdaq.com/cbicatalog/cbiproduct.asp?dept_id=101&pf_id=713.
- **BNC-16DI** – Eight-channel differential BNC connector box. Details on this product are available on our web site at www.mccdaq.com/cbicatalog/cbiproduct.asp?dept_id=101&pf_id=714.
- **SSR-RACK24*** – 24-position solid state relay rack. Details on this product are available on our web site at www.mccdaq.com/cbicatalog/cbiproduct.asp?dept_id=122&pf_id=1193.
- **SSR-RACK08*** – Eight-channel solid state relay rack. Details on this product are available on our web site at www.mccdaq.com/cbicatalog/cbiproduct.asp?dept_id=122&pf_id=620.
- **CIO-ERB24*** – 24-channel electromechanical relay accessory for digital I/O boards. Details on this product are available on our web site at www.mccdaq.com/cbicatalog/cbiproduct.asp?dept_id=123&pf_id=241.
- **CIO-ERB08*** – Eight-channel electromechanical relay accessory for digital I/O boards. Details on this product are available on our web site at www.mccdaq.com/cbicatalog/cbiproduct.asp?dept_id=123&pf_id=241.

* The SSR-RACK24, SSR-RACK08, CIO-ERB24, and CIO-ERB08 boards require the **DADP-5037** PCI-DAS-to-37-pin SSR and ERB adapter. Details on this product are available on our web site at www.mccdaq.com/cbicatalog/cbiproduct.asp?dept_id=103&pf_id=1381.

Programming and Developing Applications

After following the installation instructions in [Chapter 2](#), your board should now be installed and ready for use. Although the board is part of the larger DAS family, in general there may be no correspondence among registers for different boards. Software written at the register level for other DAS models will not function correctly with your board.

Programming languages

Measurement Computing's Universal Library[®] provides access to board functions from a variety of Windows programming languages. If you are planning to write programs, or would like to run the example programs, refer to the *Universal Library User's Guide* (available on our web site at www.mccdaq.com/PDFmanuals/sm-ul-user-guide.pdf).

Packaged applications programs

Many packaged application programs now have drivers for your board. If the package you own does not have drivers for the board, please fax or e-mail the package name and the revision number from the install disks. We will research the package for you and advise how to obtain drivers.

Some application drivers are included with the Universal Library package, but not with the application package. If you have purchased an application package directly from the software vendor, you may need to purchase our Universal Library and drivers. Please contact us by phone, fax, or e-mail:

- Phone: 508-946-5100 and follow the instructions for reaching Tech Support.
- Fax: 508-946-9500 to the attention of Tech Support
- Email: techsupport@mccdaq.com

Register-level programming

You should use the Universal Library or one of the packaged application programs mentioned above to control your board. Only experienced programmers should perform register-level programming.

If you need to program at the register level in your application, refer to the *Register Map for the PCI-DAS1000 Series* (available at www.mccdaq.com/registermaps/RegMapSTC1000.pdf).

Calibrating the Board

Introduction

Calibrate the board using the *InstaCal* utility after the board has fully warmed up. The recommended warm-up time is 15 minutes. For best results, calibrate the board immediately before making critical measurements. The high resolution analog components on the board are sensitive to temperature. Pre-measurement calibration ensures that your board is operating at optimum calibration values.

Calibration theory

The PCI-DAS1002 is shipped fully calibrated from the factory with calibration coefficients stored in nvRAM. When using Universal Library at run time, these calibration factors are loaded into system memory and are automatically retrieved each time a different DAC/ADC range is specified.

The analog input circuits are calibrated for both offset and gain (Figure 3).

- Offset calibration for the analog input is performed directly on the input amplifier (PGIA) with coarse and fine trim DACs acting on the amplifier.
- For input gain calibration, a precision calibration reference is used with coarse and fine trim DACs acting on the ADC.

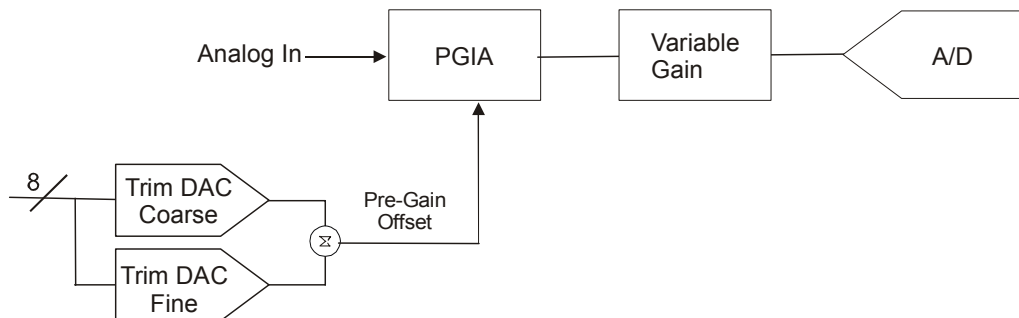

Figure 3. Analog input circuit calibration

The analog output circuits are calibrated for both offset and gain (Figure 4). This circuit is duplicated for both DAC0 and DAC1.

- Offset adjustments are made in the output buffer section. The tuning range of this adjustment allows for max DAC and output buffer offsets.
- Gain calibration is performed via DAC reference adjustments.

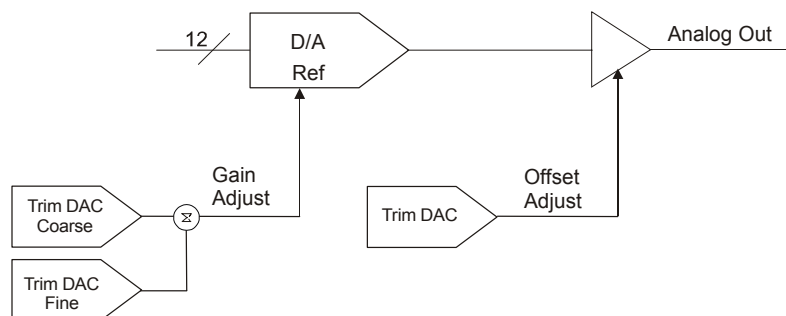

Figure 4. Analog output circuit calibration

Specifications

Typical for 25 °C unless otherwise specified.

Specifications in *italic text* are guaranteed by design.

Analog input

Table 1. Analog input specifications

Parameter	Specification
A/D converter type	ADS7800 or equivalent
Resolution	12 bits
Number of channels	16 single-ended / 8 differential, software selectable
Input ranges	± 10 V, ± 5 V, ± 2.5 V, ± 1.25 V, 0 to 10 V, 0 to 5V, 0 to 2.5 V, 0 to 1.25 V software programmable
A/D pacing (software programmable)	Internal counter - 82C54. External source (A/D External Pacer) software programmable for rising or falling edge Software polled
A/D trigger sources	External edge trigger (A/D EXTERNAL TRIGGER)
A/D triggering modes	Rising edge trigger
A/D pre-trigger mode	Unlimited pre- and post-trigger samples. Total number of samples must be greater than 512.
Burst mode	Software selectable option, burst rate = 150 kHz
Data transfer	From 1024 sample FIFO via REPINSW Programmed I/O
<i>A/D conversion time</i>	<i>3 μs max</i>
<i>Analog front end settling time</i>	<i>6 μs for a full scale step to 1 LSB</i>
Calibrated throughput	200 kHz
Calibration	Auto-calibration, calibration factors for each range stored on board in nonvolatile RAM
A/D full-scale gain drift	± 0.25 LSB/°C max
A/D zero drift	± 0.25 LSB/°C max
Common mode range	± 10 V min
CMRR @ 60 Hz	-70 dB min
<i>Input leakage current</i>	<i>± 20 nA max</i>
<i>Input impedance</i>	<i>10 MOhms min</i>
<i>Absolute maximum input voltage</i>	<i>± 35 volts</i>
<i>Warm-up time</i>	<i>15 minutes</i>

Accuracy

Accuracies are listed for a 200 kHz sampling rate, 100 sample average, single channel operation, a 15 minute warm-up, and operational temperatures within ± 2 °C of internal calibration temperature. The calibrator test source high side is tied to Channel 0 In and the low side is tied to AGND.

Table 2. Absolute accuracy specifications (analog input)

Range	Absolute Accuracy
± 10.00 V	± 2.5 LSB max
± 5.000 V	± 2.5 LSB max
± 2.500 V	± 2.5 LSB max
± 1.250 V	± 2.5 LSB max
0 to 10.00 V	± 2.5 LSB max
0 to 5.000 V	± 2.5 LSB max
0 to 2.500 V	± 2.5 LSB max
0 to 1.250 V	± 2.5 LSB max

Each PCI-DAS1002 is tested at the factory to assure the board's overall error does not exceed accuracy limits described in Table 2 above.

Table 3. Calibrated accuracy components (in LSB)

Range	Gain Error	Offset Error	DLE	ILE
All ranges	± 1.0 max	± 1.0 max	± 0.75 max	± 0.5 max

As shown in Table 3, total board error is a combination of gain, offset, differential linearity and integral linearity error. The theoretical worst-case error of the board may be calculated by summing these component errors. Worst case errors are realized only in the unlikely event that each of the component errors are at their maximum level, and causing error in the same direction.

Crosstalk

Crosstalk is defined here as the influence of one channel upon another when scanning two channels at the maximum rate. A full scale 100 Hz triangle wave is input on channel 1; Channel 0 is tied to analog ground at the 100-pin user connector. The table below summarizes the influence of channel 1 on channel 0 with the effects of noise removed. The residue on channel zero is described in LSB's.

Table 4. Crosstalk specifications

Condition	Crosstalk	Per channel Rate	ADC Rate
All ranges	2 LSB _{pk-pk}	100 kHz	200 kHz

Noise performance

Table 5 below summarizes the noise performance for the PCI-DAS1002. Noise distribution is determined by gathering 50 K samples at 200 kHz with inputs tied to ground at the user connector.

Table 5. Board noise performance

Range	% within ± 2 LSB	% within ± 1 LSB	LSBs	LSBrms*
0 to 1.250 V	100%	99%	4	0.61
All other ranges	100%	100%	3	0.45

* RMS noise is defined as the peak-to-peak bin spread divided by 6.6.

Analog output

Table 6. Analog output specifications

D/A converter type	AD7847AR or equivalent
Resolution	12 bits
Number of channels	2
Configuration	Voltage output, single-ended
Output range	± 10 V, ± 5 V, 0 to 10 V, or 0 to 5 V. Software selectable. Each channel independently programmable.
D/A pacing	Software
Data transfer	Programmed I/O
<i>Monotonicity</i>	<i>Guaranteed monotonic over temperature</i>
Overall analog output drift	± 0.03 LSB/ $^{\circ}$ C max
Settling time	4 μ s to 0.01% of 10 V step
Slew rate	7 V/ μ s min
Current drive	± 5 mA min
<i>Output short-circuit duration</i>	<i>Indefinite @25 mA</i>
Output coupling	DC
Output impedance	0.1 Ohm, max
Miscellaneous	<i>Double buffered output latches</i>
	Output voltage on power up and reset: ± 200 mV

Absolute accuracy

Table 7. Absolute accuracy specifications (analog output)

All ranges	± 3 LSB
------------	-------------

Calibrated accuracy components

Table 8. Calibrated accuracy specifications (analog output)

Gain error	± 1.0 LSB max
Offset error	± 0.5 LSB max
Integral linearity error	± 1.0 LSB max
<i>Differential linearity error</i>	<i>± 1.0 LSB max</i>

Each PCI-DAS1002 is tested at the factory to assure absolute accuracy.

Total analog output error is a combination of gain, offset, integral linearity and differential linearity error. The theoretical worst-case error of the board may be calculated by summing these component errors. Worst case error is realized only in the unlikely event that each of the component errors are at their maximum level, and causing error in the same direction. Although an examination of the chart and a summation of the maximum theoretical errors shows that the board could theoretically exhibit a ± 3.5 LSB error, our testing assures this error is never realized in a board that we ship.

Counters

Table 9. Counter specifications

Parameter		Specification
<i>Counter type</i>		<i>82C54</i>
<i>Configuration</i>		<i>Two 82C54 devices. 3 down counters per 82C54, 16 bits each</i>
82C54A:	Counter 0 - ADC residual sample counter	Source: ADC Clock Gate: Internal programmable source Output: End-of-Acquisition interrupt
	Counter 1 - ADC pacer lower divider	Source: 10 MHz oscillator Gate: Tied to counter 2 gate, programmable source Output: Chained to counter 2 clock
	Counter 2 - ADC pacer upper divider	Source: Counter 1 output Gate: Tied to counter 1 gate, programmable source Output: ADC pacer clock (if software selected). Available at user connector.
82C54B:	Counter 0 - pretrigger mode	Source: ADC clock Gate: External trigger Output: End-of-Acquisition interrupt
	Counter 0 - user counter 4 (when in non-pretrigger mode)	Source: User input at 100-pin connector (CTR4 CLK) or internal 10 MHz (software selectable) Gate: User input at 100-pin connector (CTR4 GATE) Output: Available at 100-pin connector (CTR4 OUT)
	Counter 1 - user counter 5	Source: User input at 100-pin connector (CTR5 CLK) Gate: User input at 100-pin connector (CTR5 GATE) Output: Available at 100-pin connector (CTR5 OUT)
	Counter 2 - user counter 6	Source: User input at 100-pin connector (CTR6 CLK) Gate: User input at 100-pin connector (CTR6 GATE) Output: Available at 100-pin connector (CTR6 OUT)
<i>Clock input frequency</i>		<i>10 MHz max</i>
<i>High pulse width (clock input)</i>		<i>30 ns min</i>
<i>Low pulse width (clock input)</i>		<i>50 ns min</i>
<i>Gate width high</i>		<i>50 ns min</i>
<i>Gate width low</i>		<i>50 ns min</i>
<i>Input low voltage</i>		<i>0.8 V max</i>
<i>Input high voltage</i>		<i>2.0 V min</i>
<i>Output low voltage</i>		<i>0.4 V max</i>
<i>Output high voltage</i>		<i>3.0 V min</i>
Crystal oscillator frequency		10 MHz
Frequency accuracy		50 ppm

Digital input/output

Table 10. DIO specifications

Digital type	82C55
Number of I/O	24 (FIRSTPORTA Bit 0 through FIRSTPORTC Bit 7)
Configuration	2 banks of 8 and 2 banks of 4 or
	3 banks of 8 or
	2 banks of 8 with handshake
Input high voltage	2.0 V min, 5.5 V absolute max
Input low voltage	0.8 V max, -0.5 V absolute min
Output high voltage ($I_{OH} = -2.5 \text{ mA}$)	3.0 V min
Output low voltage ($I_{OL} = 2.5 \text{ mA}$)	0.4 V max
Power-up / reset state	Input mode (high impedance)

Interrupts

Table 11. Interrupt specifications

Interrupts	PCI INTA# – mapped to IRQn via PCI BIOS at boot-time
Interrupt enable	Programmable. Default = disabled.
Interrupt sources	Residual sample counter A/D End-of-channel-scan A/D FIFO-not-empty A/D FIFO-half-full A/D Pacer

Miscellaneous

Table 12. Miscellaneous specifications

+5 Volts	Available at I/O connector (PC +5V)
+12 Volts	Available at I/O connector (PC +12V)
-12 Volts	Available at I/O connector (PC -12V)

Power consumption

Table 13. Power consumption specifications

+5 V	0.8 A typical, 1.0 A max
------	--------------------------

Environmental

Table 14. Environmental specifications

Operating temperature range	0 to 70 °C
Storage temperature range	-40 to 100 °C
Humidity	0 to 95% non-condensing

Mechanical

Table 15. Mechanical specifications

Card dimensions	PCI half card: 174.63 mm (L) x 106.86 mm (H) x 14.48 mm (D)
-----------------	-------------------------------------------------------------

Connector and pin out

Table 16. Main connector specifications

Connector type	100-pin high-density Robinson Nugent	
Compatible cable	C100FF-x, unshielded ribbon cable. x = length in feet	
Compatible accessory products (with C100FF-x cable)	ISO-RACK16/P ISO-DA02/P CIO-ERB24 (DADP-5037 adaptor required) CIO-SERB24/FD (DADP-5037 adaptor required) SSR-RACK24 (DADP-5037 adaptor required)	BNC-16SE BNC-16DI CIO-MINI50 (2 required) CIO-TERM100 (1 required) SCB-50 (1 required)

8-channel differential mode pin out

Pin	Signal Name	Pin	Signal Name
1	LLGND	51	FIRSTPORTA Bit 0
2	CH0 HI	52	FIRSTPORTA Bit 1
3	CH0 LO	53	FIRSTPORTA Bit 2
4	CH1 HI	54	FIRSTPORTA Bit 3
5	CH1 LO	55	FIRSTPORTA Bit 4
6	CH2 HI	56	FIRSTPORTA Bit 5
7	CH2 LO	57	FIRSTPORTA Bit 6
8	CH3 HI	58	FIRSTPORTA Bit 7
9	CH3 LO	59	FIRSTPORTB Bit 0
10	CH4 HI	60	FIRSTPORTB Bit 1
11	CH4 LO	61	FIRSTPORTB Bit 2
12	CH5 HI	62	FIRSTPORTB Bit 3
13	CH5 LO	63	FIRSTPORTB Bit 4
14	CH6 HI	64	FIRSTPORTB Bit 5
15	CH6 LO	65	FIRSTPORTB Bit 6
16	CH7 HI	66	FIRSTPORTB Bit 7
17	CH7 LO	67	FIRSTPORTC Bit 0
18	LLGND	68	FIRSTPORTC Bit 1
19	N/C	69	FIRSTPORTC Bit 2
20	N/C	70	FIRSTPORTC Bit 3
21	N/C	71	FIRSTPORTC Bit 4
22	N/C	72	FIRSTPORTC Bit 5
23	N/C	73	FIRSTPORTC Bit 6
24	N/C	74	FIRSTPORTC Bit 7
25	N/C	75	N/C
26	N/C	76	N/C
27	N/C	77	N/C
28	N/C	78	N/C
29	N/C	79	N/C
30	N/C	80	CTR6 CLK
31	N/C	81	CTR6 GATE
32	N/C	82	CTR6 OUT
33	N/C	83	N/C
34	N/C	84	N/C
35	D/A GND 0	85	CTR5 CLK
36	D/A OUT 0	86	CTR5 GATE
37	D/A GND 1	87	CTR5 OUT
38	D/A OUT 1	88	N/C
39	CTR4 CLK	89	GND
40	CTR4 GATE	90	+12V
41	CTR4 OUT	91	GND
42	A/D EXTERNAL PACER	92	-12V
43	N/C	93	N/C
44	N/C	94	N/C
45	A/D EXTERNAL TRIGGER IN	95	A/D INTERNAL PACER OUTPUT
46	N/C	96	N/C
47	N/C	97	N/C
48	PC +5V	98	N/C
49	N/C	99	N/C
50	GND	100	GND

16-channel single-ended mode pin out

Pin	Signal Name	Pin	Signal Name
1	LLGND	51	FIRSTPORTA Bit 0
2	CH0 HI	52	FIRSTPORTA Bit 1
3	CH8 HI	53	FIRSTPORTA Bit 2
4	CH1 HI	54	FIRSTPORTA Bit 3
5	CH9 HI	55	FIRSTPORTA Bit 4
6	CH2 HI	56	FIRSTPORTA Bit 5
7	CH10 HI	57	FIRSTPORTA Bit 6
8	CH3 HI	58	FIRSTPORTA Bit 7
9	CH11 HI	59	FIRSTPORTB Bit 0
10	CH4 HI	60	FIRSTPORTB Bit 1
11	CH12 HI	61	FIRSTPORTB Bit 2
12	CH5 HI	62	FIRSTPORTB Bit 3
13	CH13 HI	63	FIRSTPORTB Bit 4
14	CH6 HI	64	FIRSTPORTB Bit 5
15	CH14 HI	65	FIRSTPORTB Bit 6
16	CH7 HI	66	FIRSTPORTB Bit 7
17	CH15 HI	67	FIRSTPORTC Bit 0
18	LLGND	68	FIRSTPORTC Bit 1
19	N/C	69	FIRSTPORTC Bit 2
20	N/C	70	FIRSTPORTC Bit 3
21	N/C	71	FIRSTPORTC Bit 4
22	N/C	72	FIRSTPORTC Bit 5
23	N/C	73	FIRSTPORTC Bit 6
24	N/C	74	FIRSTPORTC Bit 7
25	N/C	75	N/C
26	N/C	76	N/C
27	N/C	77	N/C
28	N/C	78	N/C
29	N/C	79	N/C
30	N/C	80	CTR6 CLK
31	N/C	81	CTR6 GATE
32	N/C	82	CTR6 OUT
33	N/C	83	N/C
34	N/C	84	N/C
35	D/A GND 0	85	CTR5 CLK
36	D/A OUT 0	86	CTR5 GATE
37	D/A GND 1	87	CTR5 OUT
38	D/A OUT 1	88	N/C
39	CTR4 CLK	89	GND
40	CTR4 GATE	90	+12V
41	CTR4 OUT	91	GND
42	A/D EXTERNAL PACER	92	-12V
43	N/C	93	N/C
44	N/C	94	N/C
45	A/D EXTERNAL TRIGGER IN	95	A/D INTERNAL PACER OUTPUT
46	N/C	96	N/C
47	N/C	97	N/C
48	PC +5V	98	N/C
49	N/C	99	N/C
50	GND	100	GND

CE Declaration of Conformity

Manufacturer: Measurement Computing Corporation
Address: 10 Commerce Way
Suite 1008
Norton, MA 02766
USA

Category: Electrical equipment for measurement, control and laboratory use.

Measurement Computing Corporation declares under sole responsibility that the product

PCI-DAS1002

to which this declaration relates is in conformity with the relevant provisions of the following standards or other documents:

EU EMC Directive 89/336/EEC: Electromagnetic Compatibility, EN55022 (1995), EN55024 (1998)

Emissions: Group 1, Class B

- EN55022 (1995): Radiated and Conducted emissions.

Immunity: EN55024

- EN61000-4-2 (1995): Electrostatic Discharge immunity, Criteria A.
- EN61000-4-3 (1997): Radiated Electromagnetic Field immunity Criteria A.
- EN61000-4-4 (1995): Electric Fast Transient Burst immunity Criteria A.
- EN61000-4-5 (1995): Surge immunity Criteria A.
- EN61000-4-6 (1996): Radio Frequency Common Mode immunity Criteria A.
- EN61000-4-8 (1994): Power Frequency Magnetic Field immunity Criteria A.
- EN61000-4-11 (1994): Voltage Dip and Interrupt immunity Criteria A.

Declaration of Conformity based on tests conducted by Chomerics Test Services, Woburn, MA 01801, USA in September, 2001. Test records are outlined in Chomerics Test Report #EMI3053.01.

We hereby declare that the equipment specified conforms to the above Directives and Standards.



Carl Haapaoja, Director of Quality Assurance

Measurement Computing Corporation
10 Commerce Way
Suite 1008
Norton, Massachusetts 02766
(508) 946-5100
Fax: (508) 946-9500
E-mail: info@mccdaq.com
www.mccdaq.com