



NTI® NETWORK
TECHNOLOGIES
INCORPORATED

1275 Danner Dr Tel:330-562-7070
Aurora, OH 44202 Fax:330-562-1999
www.networktechinc.com

RACKMUX® Series

RACKMUX-T15-RS16/8

Rack Mount Console Terminal Drawer with Console Switch

Installation and Operation Manual



TRADEMARK

RACKMUX is a registered trademark of Network Technologies Inc in the U.S. and other countries.

COPYRIGHT

Copyright © 2003-2007 by Network Technologies Inc. All rights reserved. No part of this publication may be reproduced, stored in a retrieval system, or transmitted, in any form or by any means, electronic, mechanical, photocopying, recording, or otherwise, without the prior written consent of Network Technologies Inc, 1275 Danner Drive, Aurora, Ohio 44202.

CHANGES

The material in this guide is for information only and is subject to change without notice. Network Technologies Inc reserves the right to make changes in the product design without reservation and without notification to its users.

TABLE OF CONTENTS

INTRODUCTION	1
Console Terminal.....	1
Console Switch.....	2
MATERIALS	3
FEATURES AND FUNCTIONS	4
1. INSTALLATION	5
1.1 Rack Mounting Instructions.....	5
1.2 TERMINAL vs. SERIMUX Cable Connections.....	6
1.3 Connect Devices, Hosts, and Power.....	6
1.4 Connect the SERIMUX and TERMINAL to a Network.....	7
1.5 Power Up The RACKMUX.....	7
2. GETTING STARTED	8
2.1 Setup The TERMINAL.....	8
2.1.1 Entering TERMINAL Setup.....	8
2.1.2 Setup Directory.....	8
2.1.3 Changing The TERMINAL Operating Parameters.....	8
F2- Genrl SETUP Menu.....	9
F4- Comm SETUP Menu.....	9
2.1.4 Saving and Exiting Setup.....	9
2.2 Connect to the SERIMUX.....	9
3. USING THE SERIMUX CONSOLE SWITCH	11
3.1 Administrator Controls.....	12
3.1.1 Login as the administrator.....	12
3.1.2 Port List.....	13
3.1.3 Port Settings.....	14
3.1.3.1 Port serial settings.....	16
3.1.3.2 Modem settings.....	18
3.1.3.3 Port data buffer.....	19
3.1.4 User List.....	20
3.1.5 User Settings.....	21
3.1.5.1 Port access.....	22
3.1.5.2 Copy User Settings.....	22
3.1.6 Advanced Settings.....	23
3.1.6.1 Change administrator password.....	23
3.1.6.2 Firmware.....	24
3.2. User Controls.....	26
3.2.1 User "Accessible host list" screen.....	26
3.2.2 User main menu.....	27
3.2.3 Port List screen.....	28
3.2.4 User Terse mode.....	29
3.2.4.1 Terse mode commands.....	29
3.2.5 Initialize SERIMUX Console Switch to default settings.....	30
4. USING THE TERMINAL	32
4.1 How To Setup The TERMINAL.....	32
4.1.1 Entering TERMINAL Setup.....	32
4.1.2 Saving and Exiting Setup.....	32
4.1.3 Setup Directory.....	32
4.2 Changing The TERMINAL Operating Parameters.....	33
F1- Disp SETUP Menu.....	33
F2- Genrl SETUP Menu.....	33
F3- Keybd SETUP Menu.....	34
F4- Comm SETUP Menu.....	34
F5- Misc SETUP Menu.....	35
F6-Tabs SET-UP Menu.....	35

F7- FKeys SET-UP Definition Setup Menu	35
F8- Ansbk SET-UP Menu	36
F9- Lan Setup Menu	36
F10- Colr1 Set-up Menu	36
F11- Colr2 Set-up Menu	37
4.3 Local Keyboard Commands	40
4.4 TERMINAL Command Guide	41
4.4.1 Commands Supported in ASCII Personalities	41
4.4.2 Variable Values for Table 8 Commands	48
4.5 ANSI Command Guide	52
4.5.1 VT100, VT220 and Console ANSI Command Guide	52
4.5.2 VT52 Command Guide	59
4.6 Using Printer Server via Ethernet Connection	60
4.6.1 Basic Setup	60
4.6.2 Setup for LPD	61
4.6.3 LPD printing	62
4.6.4 Setup for TFTP	62
4.6.5 TFTP Printing	62
4.7 On-Screen Display (OSD)	63
4.7.1 Standard Controls	63
4.7.2 OSD Control Menu	63
4.7.2.1 OSD Main Menu	63
4.7.2.2 Brightness/Contrast Menu	64
4.7.2.3 Color Menu	64
4.7.2.4 Position Menu	64
4.7.2.5 Setup Menu	65
4.8 Keyboard Functions	66
4.8.1 Number Pad	67
5. HARDWARE INFORMATION	68
5.1 Hardware Specifications: TERMINAL	68
5.2 Hardware Specifications: SERIMUX	68
5.3 CPU-to-RACKMUX Ethernet Crossover Cable	69
5.4 Serial Port Cabling	69
5.5 Serial Port Pinouts	69
5.6 Cable Adapters	70
5.7 SERIMUX Ethernet Pinouts	71
5.8 TERMINAL Connector Pin Assignments	72
5.9 Dimensional Drawings	73
INDEX	74
WARRANTY INFORMATION	74

TABLE OF FIGURES

Figure 1- Mount RACKMUX to rack	5
Figure 2- Distinction of connections between TERMINAL and SERIMUX	6
Figure 3- Connect serial devices, printer, and power supply	6
Figure 4- Connect to a Local Area Network (LAN).....	7
Figure 5- Fields in the Setup menu display which function keys to press for submenus	8
Figure 6- Startup- Accessible host list	10
Figure 7- Administrator main menu.....	12
Figure 8- The Port list displays the status of all ports	13
Figure 9- The Port settings menu	14
Figure 10- Control Codes for in-band disconnect sequence.....	15
Figure 11- Port serial settings menu	16
Figure 12- Modem settings menu	18
Figure 13- Port data buffer	19
Figure 14- User List	20
Figure 15- User settings menu.....	21
Figure 16- Port access list for User 01	22
Figure 17- Administrator's Advanced settings menu.....	23
Figure 18- Firmware menu.....	24
Figure 19- The SERIMUX is waiting to save its firmware.....	25
Figure 20- A user with limited host port access	26
Figure 21- User main menu	27
Figure 22- A limited user accessible Port list	28
Figure 23- User port in Terse mode	29
Figure 24- Location of RESET button	30
Figure 25- Fields in the Setup menu display which function keys to press for submenus	32
Figure 26- OSD Controls	63
Figure 27- Keyboard Layout	66
Figure 28- Keys of the Number Pad	67

List of Tables

Table 1- Main Setup Menu (F12) Exit Functions.....	9
Table 2- SERIMUX Port Characteristics	31
Table 3- Main Setup Menu (F12) Exit Functions.....	32
Table 4- Programmable Keys	36
Table 5- Color Setup Menu.....	37
Table 6- Color Palettes	38
Table 7- Local Keyboard Commands in Native Mode.....	40
Table 8- Commands Supported in ASCII Personalities	41
Table 9 -Supported VT100,VT220 and Console ANSI Commands	52
Table 10- VT52 Mode Escape Sequences	59
Table 11- Number Pad Keys.....	67

INTRODUCTION

The RACKMUX-T15-RS16 Rackmount Console Terminal Drawer with 16 port Console Switch (RACKMUX) places a VT100/ANSI Terminal and a Console Switch right in the rack for space-saving, convenient control of SUN or PC-based headless servers, routers, and firewalls. The LCD monitor terminal drawer eliminates the need for an external laptop or table-top dumb terminal. The Console Switch delivers control of up to 16 serial devices via Ethernet, LAN or dial-up modem connections. It enables unlimited access to remote network management, providing optimum system performance and availability.

Optional:

- RACKMUX-T15-RS8 Rackmount Console Terminal Drawer with 8 port Console Switch
- Anti-glare protective glass for the LCD- Add G to the model number (i.e. RACKMUX-T15G-RS16)
- RL-T15-TEL- Mounting bracket for 2-post style Telco Rack

Console Terminal

The Console Terminal (TERMINAL) is easy to install and configure for either of the following communication modes:

- **RS232 Terminal** (using an RS-232 port for serial console connection). Use this configuration of the Console Terminal with the Console Switch to control multiple servers.
- **Telnet Terminal** (using an RJ45 10Base-T network port for Ethernet telnet console connection). The Ethernet connection can be used with any 10Mb-compatible Ethernet host adapter, but is most suited for use with SUN RSC (Remote System Control) Ethernet ports, since these provide the same functionality as serial (ttya) console ports. This connection supports up to 12 telnet sessions to different servers. The state of each server session is preserved by the terminal. Terminal sessions can be switched via hot-keys. When using the Ethernet telnet connection, the Terminal Drawer can be connected to multiple servers via an Ethernet switch. However, it is advisable that the network used to connect the server consoles remains private for security reasons.

Note: Both RS232 serial and Ethernet telnet connections cannot be active at the same time.

The TERMINAL is a general purpose character terminal drawer offering full transaction capabilities and is largely pre-configured for most applications. It was designed in conjunction with SUN Microsystems to ensure flawless compatibility with all SUN servers. It is also compatible with most racks, including the Sun StorEdge 72", Sun Fire, and most EIA 19" racks. This console drawer is the ideal solution for controlling web servers, DNS servers, mail servers and other equipment that lack video card capability, such as the SUN Netra systems and HP servers.

Features

- Entire unit is only 1U (1.75") high.
- High-quality metal construction (ideal for most industrial and commercial settings)
- 15" TFT Rack Mount LCD Monitor features a wide viewing angle.
- Screen size: 80x24 characters plus status line.
- Keyboard lock prevents unauthorized use
- 800x600 resolution.
- LCD Display controls (using on-screen menu).
- 83-key keyboard.
- Supports RSC capabilities.
- Serial and parallel slave-printer ports.
- Includes rack mount kit suitable for SUN and most EIA 19" racks
- Fits 22" to 36" rack depths via adjustable mounting brackets.
- Connects to 10BaseT Ethernet port

Multiple RS-232 Emulations:

- | | | |
|----------------|----------|----------|
| • ADDS A2 | • TV1925 | • WY-60 |
| • PC TERM | • VT52 | • WY-100 |
| • PCG Alpha | • VT100 | • WY-120 |
| • Console ANSI | • VT220 | • WY-325 |
| • TVI910+ | • WY-50+ | |

Compatibility

- Compatible with any SUN or PC-based headless server.
- Communicates with routers, bridges, firewalls, and hubs

Console Switch

The Console Switch (SERIMUX) includes a text-based menu for easy connection management for administrators. Using a terminal emulator the menu provides a quick means for user serial connection changes and device control.

The Console Switch (SERIMUX) is a serial port router that allows links (or connections) between multiple pairs of RS-232 asynchronous serial ports. The main purpose of the switch is to enable users to manage several serial devices from local or remote locations (using external modems). Devices include routers, DSU's, servers, switches or any other equipment allowing serial operation using RS232 interface. Users can work locally (using a VT100 or ANSI serial console or a CPU with a terminal program (i.e. HyperTerminal)) or from remote locations.

Each SERIMUX port has to be configured for serial communication (baud rate, parity, etc) within the specifications of the attached serial device, but the configurations of the two devices linked by the SERIMUX do not need to match. Various parameters (communication speed, hardware and/or software flow control, timeout, etc) can be selected for each SERIMUX port. Devices may be either locally connected or connected through attached modems.

Each SERIMUX port can be configured as either a host or user port. Serial hosts (such as servers, switches etc.) are connected to host ports, while serial user devices (such as a terminal or serial console) are connected to user ports.

The SERIMUX Console Switch supports two operator levels: user and administrator. Users login at user ports and connect to serial devices attached at host ports. The administrator (logged in at any user port) and users with administrative privileges can see and/or modify various port or user parameters.

Features

The SERIMUX provides secure, flexible management of servers, routers, switches, and other networked devices. Key features include:

- Eliminates the need to connect each device to an ASCII terminal or PC
- Connect up to 32 devices with different baud rates, parity, and character length. Each switch also has one RJ45 connector for the local terminal
- Provides out-of-band access to network devices (servers, routers, network switches, and any other network devices allowing console operation using RS232)
- No inadvertent "break" signals are generated to cause unintentional rebooting of SUN computers
- Available with an optional 48V DC-DC power converter for telecom environments
- Two operator levels (administrator and user)
- Switching is simplified with programmable device names and menu-driven device selection
- Built-in data buffers save the most RS232 console output from each connected device, which simplifies troubleshooting failures
- Local commands can be directed via VT52, VT100, ANSI serial console, a PC with a terminal emulation program, or any compliant terminal
- The SERIMUX can be power cycled without halting a SUN host computer
- Gain access to servers without interrupting service to end-users; maintain optimal up-time
- Manage server farms or data centers via serial ports and standard external modems

MATERIALS

Materials Supplied with the NTI RACKMUX-T15-RS16 Rackmount Console Terminal Drawer with Console Switch:



110-240VAC, 50 or 60Hz-12VDC/4A
AC Adapter



DB25M-RJ45F-C
Modem Adapter



DB9F-RJ45F
Serial Adapter



RJ45F-T – DB25M
Console Adapter



DB25F- RJ45F
Console Adapter



2 Keys for Lock



CD and Quick Start Guide



2 rear mounting brackets w/ 4 nuts



8- #10-32x3/4” screws and cage nuts

Materials Not Supplied, but REQUIRED:

Serial cable with at least one RJ45 male end for connection to the Console Switch from each device to be connected. See Interconnection Cable Wiring Method on page 29 for cable pinout.

Note: In order to comply with FCC standards, the SERIMUX requires the use of a shielded Category 5 cable connected to the Ethernet Interface

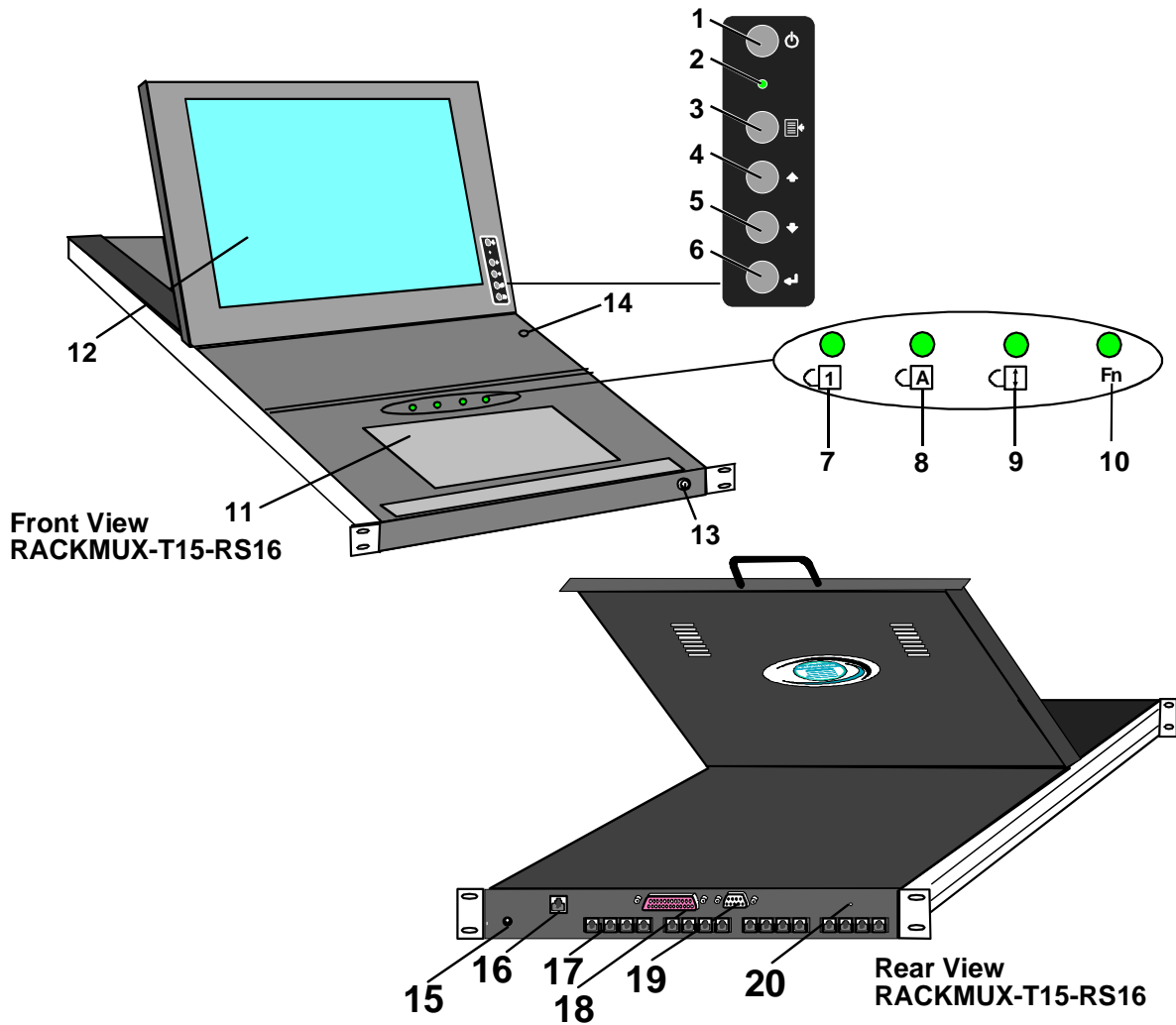

FEATURES AND FUNCTIONS

1. **Power Button**- press to turn the LCD monitor ON and OFF
2. **Power LED**- indicates operation status
Green=Power-On, Video Input Signal OK
Red = Suspend / Stand-by, or no Video Input Signal
3. **Menu Button**- press to turn ON the OSD menu
4. **Up Arrow Button**- press to move the cursor in the OSD menu up
5. **Down Arrow Button**- press to move the cursor in the OSD menu down
6. **Select Button**- press to select a menu item (when OSD menu is ON) or press to auto adjust the video quality (when OSD menu is OFF)
7. **NumLock LED**- illuminates when the number lock is ON
8. **CapsLock LED**- illuminates when the keyboard is locked to type all capital letters
9. **Scroll Lock LED**- illuminates when the Scroll Lock keyboard feature is ON.
10. **Fn LED**- illuminates when the number pad features are enabled.
11. **Keyboard**- for manual data entry and computer control
12. **LCD Display**- for viewing the video signal from the connected CPU
13. **Key Lock**- to secure the keyboard in a closed position preventing unauthorized use
14. **Auto Shut OFF Switch**- automatically shuts OFF the LCD display when the monitor is folded down
15. **12VDC- Power Socket**- for connection of 12VDC AC adapter
16. **Ethernet-RJ45 Connector**- Ethernet 10/100- for TERMINAL connection to Ethernet
17. **RJ45 Connectors**- for attaching CAT5 cables from serial devices
18. **Parallel**- Female SUB D 25 connector- for attaching local printer with parallel printer cable
19. **Serial**-Male SUB D 9 connector- for attaching a local printer serially
20. **Reset**- button to reset SERIMUX to factory default settings

1. INSTALLATION

1.1 Rack Mounting Instructions

The RACKMUX was designed to be mounted to a rack and includes mounting flanges to make attachment easy.

1. Determine the mounting height in the rack for the drawer. It should be a height comfortable to use the keyboard and see the LCD display. Mark holes in each of the 4 corner cabinet rails at points all level with each other.
2. Secure the rear brackets to the rear rack cabinet rails at the holes marked in step 1 using #10-32x3/4" screws and cage nuts (supplied). Be sure to tighten the screws securely.
3. Lift the keyboard into position and line the studs on the left and right sides up with the slotted openings in the rear bracket. Apply the nuts (supplied) to the studs but do not tighten the nuts yet.

FYI: There are 5 mounting studs provided on each side of the RACKMUX. Depending on the depth of the rack and distance apart of the cabinet rails, the position of the rear bracket may make all 5 studs available for use. In this case, apply the 2 nuts to the studs furthest apart from each other on each side.

4. Slide the drawer in until the top holes in the front bracket flanges line up with the holes marked in step 1. Secure the front brackets on the drawer to the front cabinet rails using #10-32x3/4" screws and cage nuts (supplied). Be sure to tighten the screws securely. Then tighten the nuts applied in step 3.

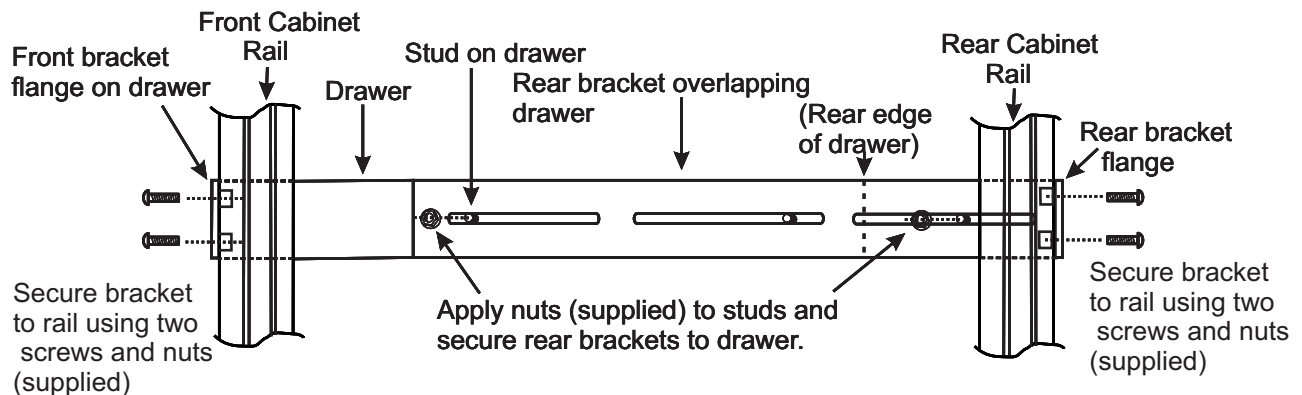

Figure 1- Mount RACKMUX to rack

1.2 TERMINAL vs. SERIMUX Cable Connections

The connectors on the rear of the RACKMUX are split between those for the TERMINAL connections, and those for the SERIMUX connections (see Fig. 2).

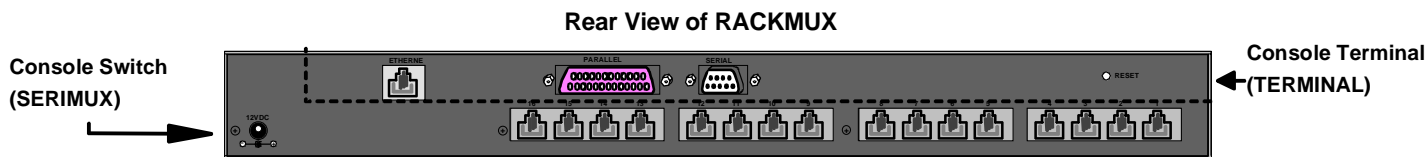

Figure 2- Distinction of connections between TERMINAL and SERIMUX

1.3 Connect Devices, Hosts, and Power

1. Connect each serial device or host to be connected by the SERIMUX to any port labeled "1" through "16" using a DTE or DCE type serial cable. It may be necessary to add one of the cable adapters (supplied) detailed in "Cable Adapters" (page 95) between the device port on the serial device or host and the RJ45 connector.

Note: There are two types of serial devices, data communication equipment (DCE)(i.e. modem) and data terminal equipment (DTE) (i.e. CPU), each having different connector pin assignments. The cable adapters (see Materials on page 3) make the proper connections.

2. If connecting a printer, connect either a serial printer cable to the remaining male SUB D 9 connector or a parallel printer cable to the female SUB D 25 connector (see Fig. 3).
3. Connect the 12VDC AC adapter to the power jack labeled "12VDC".

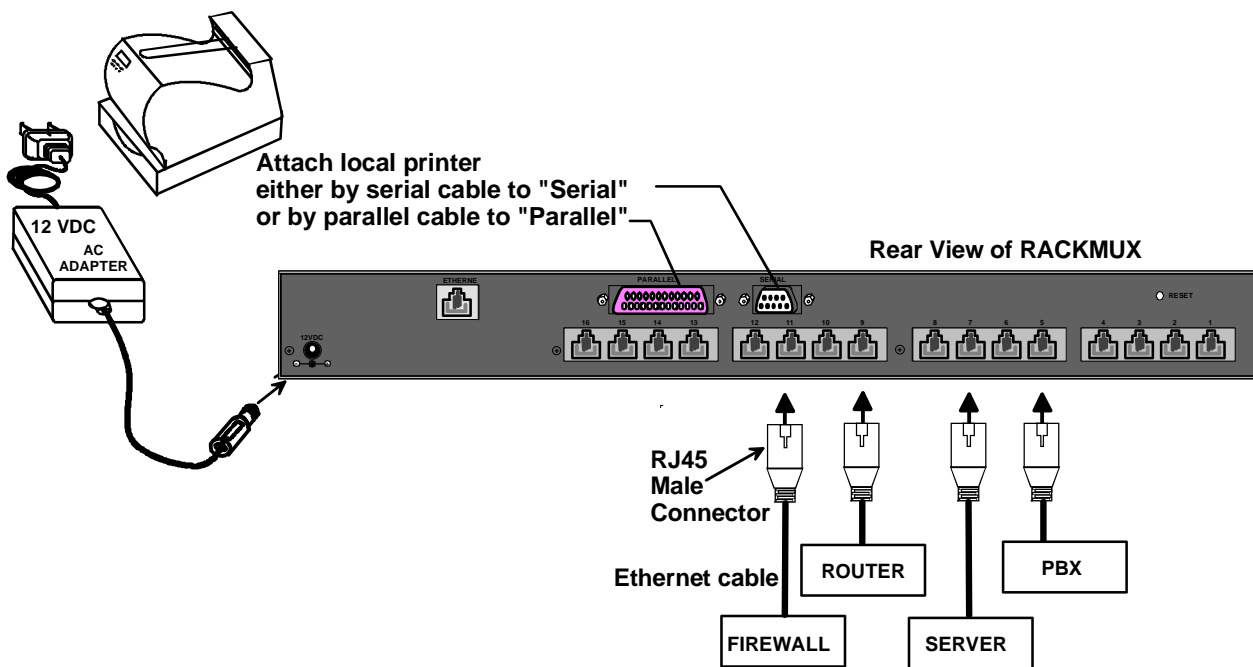

Figure 3- Connect serial devices, printer, and power supply

1.4 Connect the SERIMUX and TERMINAL to a Network

To control the SERIMUX and TERMINAL through a network connected PC, connect a CAT5 Ethernet network cable to the connector marked "ETHERNET". Then connect the other end of the Ethernet cable to a Local Area Network (LAN) through a 10/100 BaseT switch or hub. (See Fig. 4.)

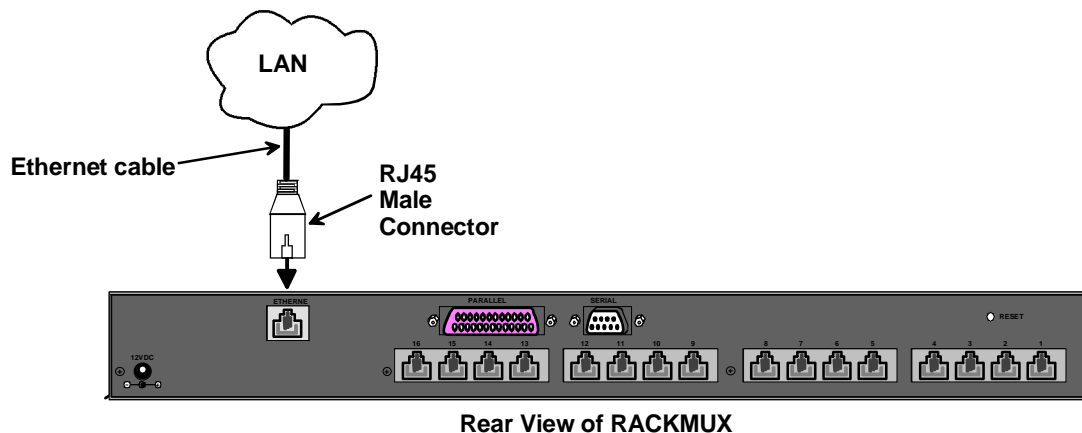

Figure 4- Connect to a Local Area Network (LAN)

Alternatively, the RACKMUX may be directly connected to PC using a CAT5 Crossover cable. See page 67 for specifications.

1.5 Power Up The RACKMUX

1. Connect the AC adapter to a power source.
2. Using the key, unlock the drawer and slide the keyboard and LCD Display out far enough to raise the display to a comfortable viewing angle.
3. Press the Power button (page 4, item 1) on the LCD monitor.
4. Adjust the screen's brightness and contrast with the controls located on the LCD monitor— as needed. See page 45 for more on OSD controls.

2. GETTING STARTED

Introduction

This chapter covers basic configuration topics. Included is information on setting up the TERMINAL to control the SERIMUX.

1. Using the instruction under "Setup The Terminal" below (or more detailed instruction on page 31), setup the TERMINAL to make connection to the SERIMUX. Configure the terminal as follows:
 - Ethernet Mode set to OFF (F4 menu)
 - Baud rate at 9600 bps (F4 menu)
 - 8 bits (F4 menu)
 - no parity (F4 menu)
 - 1 stop bit (F4 menu)
 - no flow control (F4 menu)
 - ANSI or VT100 terminal mode (F2 menu).

Within the SERIMUX firmware, the "CONSOLE" port is the internal connection between the TERMINAL and the SERIMUX. For consistency, when Port 0 is mentioned within this manual, it refers to the connection made by the TERMINAL.

2.1 Setup The TERMINAL

To control the SERIMUX some initial settings must be configured in the TERMINAL.

2.1.1 Entering TERMINAL Setup

Hold down the <ALT> key and press the <Esc> key to enter Setup mode. When entering Setup, any text on the screen temporarily disappears, and the main SETUP directory appears (See Figure 5). When leaving the Setup mode, the main SETUP directory disappears, and any text that was on the screen will reappear.

2.1.2 Setup Directory

The fields at the bottom of the screen show the various setup menus where the terminal's operating parameters can be changed and the function key to press to immediately display any menu.

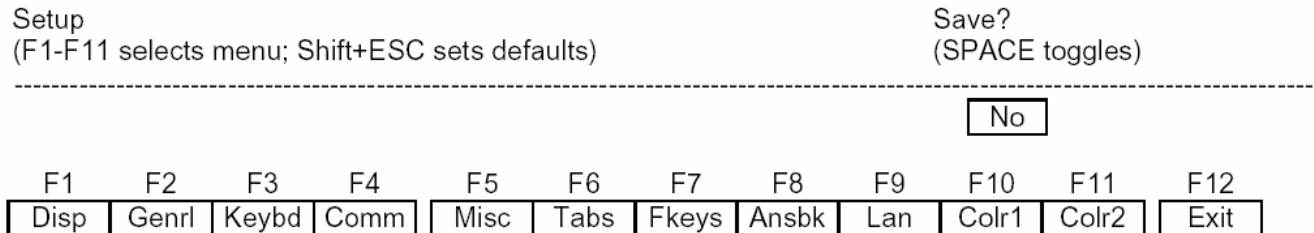

Figure 5- Fields in the Setup menu display which function keys to press for submenus

2.1.3 Changing The TERMINAL Operating Parameters

To select one of the setup menus shown, press the indicated function key.

- The screen for that menu appears with the name highlighted.
- The fields at the middle of the screen indicate the parameters that can be changed in that menu.
- The top line identifies the keys to press to highlight the parameter fields and change the settings.

- The procedure is: (1) Use arrow key to highlight the parameter field to be changed.
 (2) Use the Spacebar to change the parameter.

<F12> always returns the user to the top menu.

The following lists only what is necessary to connect to SERIMUX. For a complete list of features, see page 30.

F2- Genrl SETUP Menu

Personality set to Digital Equipment VT-100 or Console ANSI

F4- Comm SETUP Menu

Baud Rate set to 9600

Ethernet Mode set to OFF to set the communication routing by Serial Port.

Data / Stop Bits set to send and receive 8-bits data with one stop bit

Xmt Handshake set to None

Parity set to none

2.1.4 Saving and Exiting Setup

The first menu seen when entering Setup serves as a directory to the other Setup menus. To exit Setup or any submenu, press <F12>. Pressing <F12> will return the display to the main Setup directory and with another press of <F12> the user will exit Setup.

The highlighted field at the right of the screen gives the user the choice of saving or not saving parameter changes into memory before returning the TERMINAL to the normal operating mode. Settings changed will effect the operating environment until the TERMINAL is powered-down. Setting changes will only be restored at power-up if they are saved before exiting Setup.

NOTE: If settings are not saved before exiting Setup, any new selections will be lost when the RACKMUX is powered-down.

To save Setup selections, depress the Spacebar to change the save field at the right side of the screen from NO to YES before exiting Setup. (Table 1 describes your options for exiting Setup.)

Depress <F12> to leave Setup and return to the normal display mode.

Table 1- Main Setup Menu (F12) Exit Functions

Option	Function
No	Returns terminal to normal operating mode without saving parameters changes for power up
Yes	Saves all changes (operating parameter, tabs, key definition, and answerback message); returns terminal To its normal operating mode.
Shift + Esc	Restores all setting (operating parameters, tabs, key definitions, and answerback message) to their factory default values.

For changes to the TERMINAL settings to take effect, the RACKMUX must be power cycled. Disconnect power from the AC adapter and reconnect.

2.2 Connect to the SERIMUX

1. Press [Enter] on the keyboard to be recognized as the default SERIMUX user. The "Accessible host list" for "User01", logged in at "Port00" will be displayed (see Fig 6). By default, all ports are configured as Host ports and all are accessible.

NOTE: If the user menu does not display re-initialize the SERIMUX following the "Initialize SERIMUX Console Switch to default settings" instructions on page 30.

- To connect to an attached CPU, enter the number of the port the CPU is connected to and press [Enter].

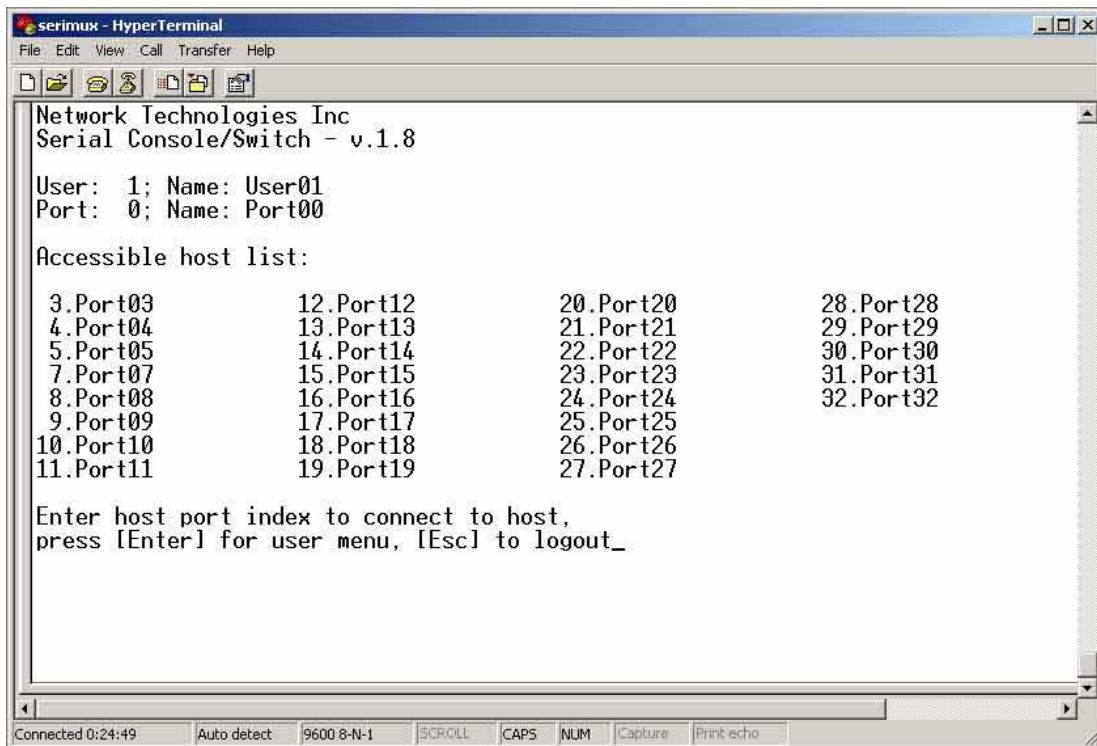

Figure 6- Startup- Accessible host list

3. USING THE SERIMUX CONSOLE SWITCH

The SERIMUX Console Switch is controlled using the TERMINAL and menu-driven integrated software.

The SERIMUX can be easily configured using the TERMINAL with a keyboard-controlled menu to modify various parameters and options for each port to be connected to a device. The administrator menu can be accessed by the administrator for full feature control, or the user menu, by any user, for more restricted control of port connections.

The SERIMUX supports 2 operator levels, administrator and user, each with separate password protection for security.

- The administrator logs in using an administrator password (see next page for login procedure)

administrator name : ADMINISTRATOR or ROOT (all capital letters)

default administrator password : NTI (all capital letters)

- Users login using a password set by the administrator

FYI: Users may be granted administrative access rights by the administrator.

The administrator and any user with administrative rights is able to:

- view / modify port parameters;
- view / modify user parameters and user access rights to ports;
- disconnect ports, logout users etc.

The administrator name cannot be changed.

To change the administrator password, see page 23.

3.1 Administrator Controls

3.1.1 Login as the administrator

1. The TERMINAL must first be configured (and is typically delivered preconfigured) as described on page 8 under "Getting Started".

Note: *The administrator can only login from the TERMINAL connection (serially). Be sure that the Ethernet Mode is set to OFF (page 9) before trying to login as administrator.*

2. Press [Enter] on the keyboard and the port will open to the "Accessible host list" for "User01", logged in at "Port00".
3. Press [Esc] to logout, and [Y] to confirm. A message will be displayed "Disconnecting user now"
4. Press [Spacebar] or [Enter]. A prompt requesting a Username will appear.
5. Enter **ADMINISTRATOR** or **ROOT** (all capital letters) and press [Enter]. A prompt for a password will appear.
6. Enter **NTI** (all capital letters) and press [Enter]. The Administrator main menu will appear for user ROOT on port 0.

Note: *This will only enter the administrator mode if the administrator password has not yet been changed from "NTI".*
FYI: *If SERIMUX is not at initial power-ON, omit steps 2 and 3 above to login.*

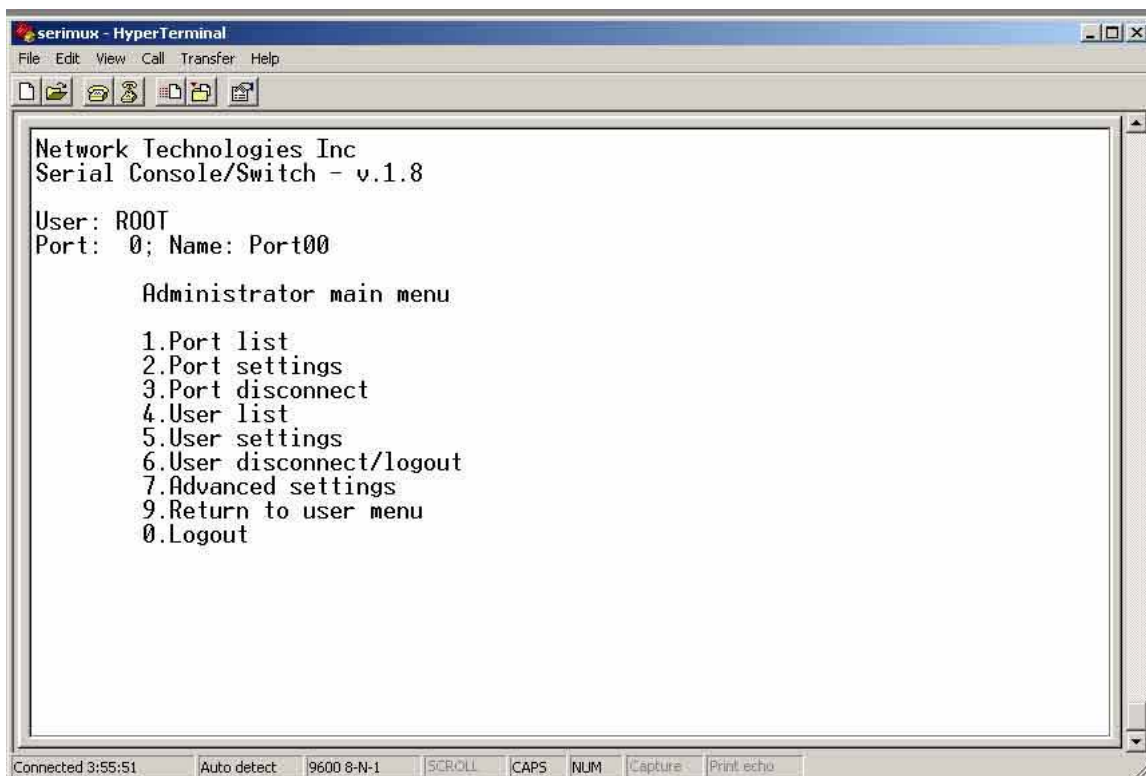

Figure 7- Administrator main menu

FYI: *The Administrator main menu will also appear if a user with administrative privileges presses [4] from the User main menu.*

From the Administrator main menu, the following options are possible:

Function	Description	Keystroke
Port List	Display the port list	[1]
Port settings	View or modify any port settings	[2]
Port disconnect	Disconnect any port and logout the user logged in or connected to the port	[3] + [port number]
User list	Display the user list	[4]
User settings	View or modify user settings	[5]
User disconnect/logout	Disconnect and logout any user connected to a port	[6]
Advanced settings	View or modify advanced administrative settings (pg 17)	[7]
Return to user menu	Leave the administrative menu and return to the User main menu	[9]
Logout	Logout from SERIMUX	[0]

3.1.2 Port List

From the Administrator main menu, press [1] to display the Port List.

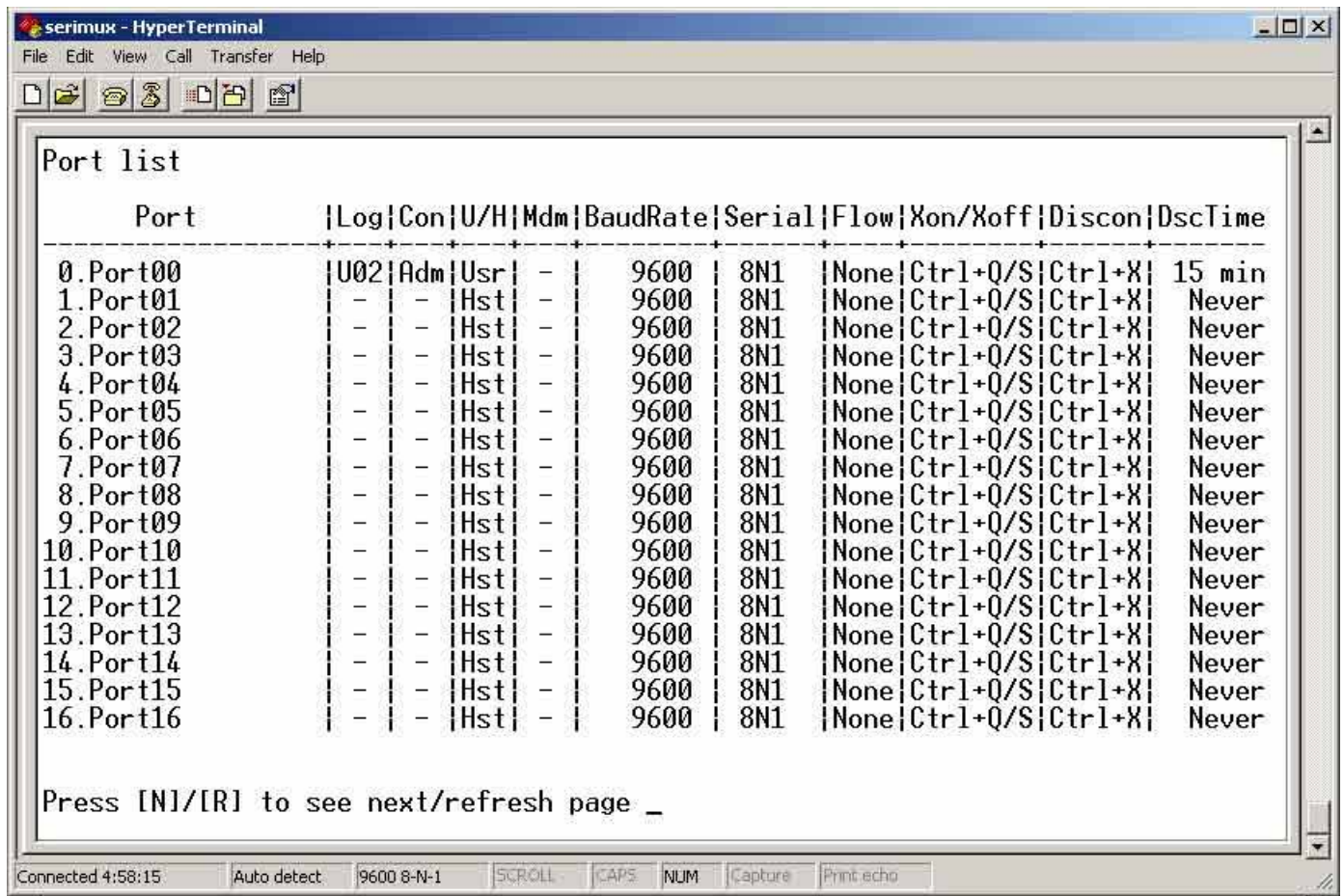

Figure 8- The Port list displays the status of all ports

The Port list displays the following information:

Column Heading	Description
Port	Port number and name
Log	Index number of the user logged in at the port
Con	The number of another port (Pxx) connected to that port . If the administrator is logged in, "Adm" will be displayed
U/H	Port type- User or Host
Mdm	Modem connection status: Y if modem is connected , - if not
BaudRate	Port transmitter and receiver speed
Serial	Character size, parity, and stop bit number
Flow	Flow control method- hard (RTS/CTS), soft (Xon/Xoff), both, or none
Xon/Xoff	Special characters used as soft flow control sequence
Discon	In-band disconnect sequence (1 character, 3 character, or none)
DscTime	Remaining time until self-disconnection due to port receiver inactivity (see below)

FYI: RE: DscTime (Disconnect Time)

The value shown in the Port list is derived from various sources depending on the type of connection active at the time.

- If a user is logged into a port as just a user, the time shown will be the remaining time based on the user's timeout setting.
 - If a user is logged in with administrative privileges and performing administrative tasks, the time will be based on the administrator's timeout setting, not based on the user's timeout setting.
 - If two ports are connected to each other, and one port has a lower timeout setting than the other, the lower setting will be shown in the DscTime column and control the connection.
- Press [N] to display port information for ports greater than 16, and then [P] to see the previous page.
 - Press [R] to refresh the information displayed
 - Press [Esc] or [Spacebar] to return to the Administrator main menu

3.1.3 Port Settings

From the Administrator main menu, press [2]-[x]-[Enter] where x is the number of the port to display the port settings for.

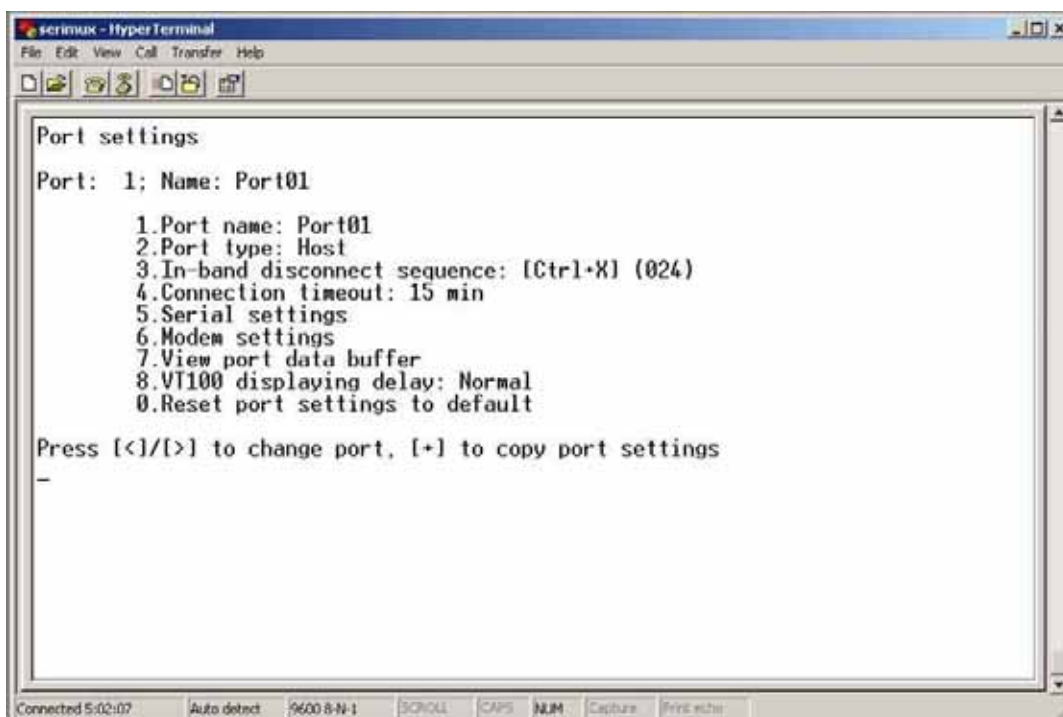

Figure 9- The Port settings menu

From the Port settings menu, the configuration of each port can be viewed and changed.

Setting	Description	Value
Port name	Change the port name	Max. 15 characters
Port type	Host or User	H or U
In-band disconnect sequence	Select characters to use for in-band disconnect sequence	1 + code for 1-character sequence (see Fig. 6 below) 3 + desired characters for 3-character sequence 0- for no disconnect sequence T- display Control code list
Connection Timeout	Time left before connection will be broken due to receiver inactivity	0-90 minutes. If 0 is selected, the connection will never timeout.
Serial settings	Display serial settings menu	N/a
Modem settings	Display modem settings menu	N/a
View port data buffer	View the last 1016 characters received and transmitted to/from the port	N/a
VT100 displaying delay	Modify the displaying extra delay	0 = None, 1 = normal, 2 = double, or 3 = triple "None" value can be used if the display is faster (i.e. with a terminal emulator, like HyperTerminal, running on a PC); the other values are useful if real terminals or slower serial devices are used as user/administrator consoles.
Reset Port settings to default	Restores factory default port settings	A confirmation "Y" will be required

When [3] is pressed to change the in-band disconnect sequence, the choices provided are 0, 1, 3, or T. Pressing a [T] will bring up a Control code list containing key sequences used for 1-character sequences, and the ASCII codes associated with each. (See Fig 6) To set a 1-character sequence, press [1], then the code from the table associated with the desired sequence.

Note: If the 3-character disconnect sequence is enabled, the string: [CR][LF]<3-char sequence>[CR][LF] has to be received to break the connection (7 characters). The [CR] and [LF] ASCII characters stand for 13 and 10 decimal codes (ASCII Carriage Return and Line Feed) respectively.

FYI: If the 1-character sequence is selected, the connected device will not receive the disconnect character. If the 3-character sequence is selected, it will be sent to the connected device, prior to breaking the connection.

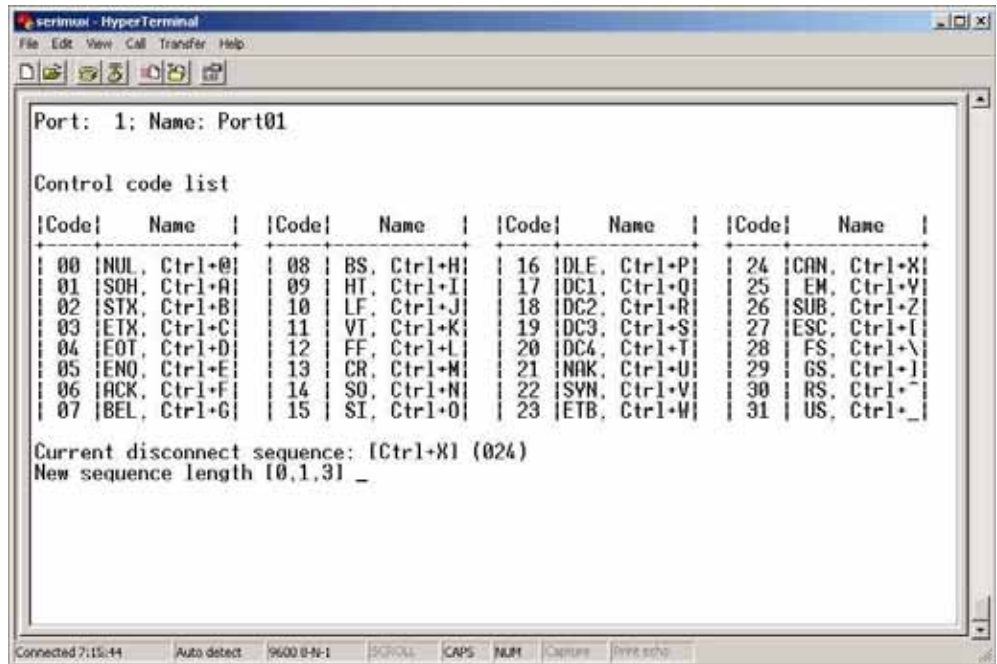

Figure 10- Control Codes for in-band disconnect sequence

- When selecting each new port setting values, press [Esc] or [Spacebar] to cancel, or press [Enter] to save.
- Press [>] (greater than symbol) to display the current settings for the next port.
- Press [<] (less than symbol) to display the current settings for the previous port
- Press [Esc] or [Spacebar] to return to the "Administrator main menu"

3.1.3.1 Port serial settings

From the "Port settings" menu, press [5] to display the "Port serial settings" menu. Using this menu, the administrator can adjust the serial settings of each port, or copy the current port serial settings and paste them to another port or to all ports.

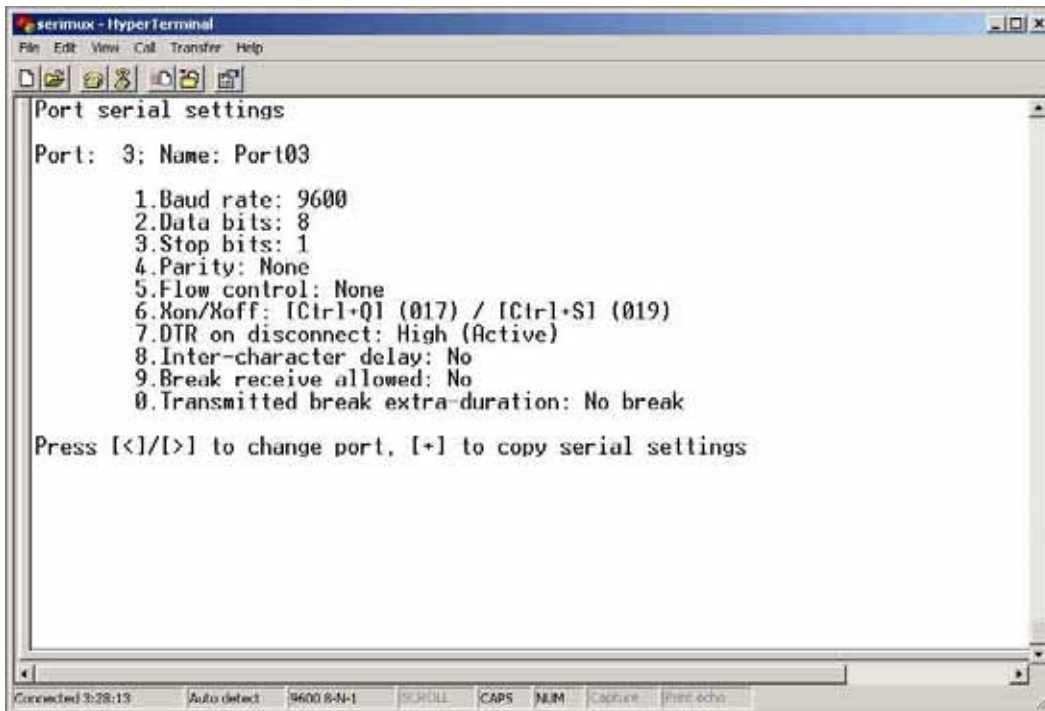

Figure 11- Port serial settings menu

3.1.3.1.1 Baud rate

Any baud rate (serial speed) between 50 bps - 128Kbps can be selected, (except for port 0, between 300 bps - 115.2 Kbps). To modify the port serial speed (baud rate);

- press [1],
- enter the new value or press [T] for a table listing standard baud rates supported,
- and press [Enter]. A confirmation will be required for non-standard baud rate values.

3.1.3.1.2 Data bit

The data bit number can be 5, 6, 7, 8, (except for port 0: 7 or 8).

To modify the data bit number;

- press [2],
- then the bit number: 5, 6, 7, 8

3.1.3.1.3 Stop Bit

The stop bit number can be 1, 2, 1.5 or 2.5, (except for port 0: 1 or 2 stop bits).

To modify the stop bit number;

- press [3],
- then [1] or [2] or [A] or [B] to select 1, 2, 1.5 or 2.5 stop bits respectively.

3.1.3.1.4 Parity

Parity is set by pressing [4], then [N] for none, [E] for even, or [O] for odd.

3.1.3.1.5 Flow Control

The flow control (hand shaking) can be hardware (RTS/CTS or out-band), software (Xon/Xoff or in-band), both or none.

To select the flow control;

- press [5],
- then [H] or [S] or [B] or [N] respectively.

Note: If "N" for "none" is selected, data may be lost when sending large (greater than 1000 byte) data packets.

Note: If a modem is attached to the port, and hardware and/or software flow control is used, the appropriate command may be added to the modem initialization string:

Flow control	Command 1	Command 2
None	–	–
RTS/CTS (hardware)	&K3	\Q3
Xon/Xoff (software)	&K4	\Q1
Both	&K6	
disable flow control (not necessary)	&K0	\Q0

Consult your modem user manual or the modem AT command manual to find the suitable command.

3.1.3.1.6 Xon or Xoff Characters

Any non-printable character (ASCII codes between 0 and 31) can be used as flow control Xon or Xoff character. The software flow control is transparent, so the special character is not passed to the connected device. If the Xon and Xoff characters are equal, a toggle mode is automatically used in the software flow control: whenever the special flow control character is received, the current state of flow control is toggled.

To change the Xon or Xoff character;

- press [6],
- then [0] for Xoff or [1] for Xon,
- enter the new value,
- then press [Enter] to save it, [Esc] or [Space] to cancel.

FYI: Press [T] after [6] to display a control codes table.

3.1.3.1.7 DTR line behavior

If a modem is not attached to the serial port, the DTR port line behavior on port disconnection can be selected as follows: the DTR line can be held high (active), low (inactive) or pulsed for 0.5 seconds and then held high. When a modem is attached to the port, the DTR line will be pulsed on port disconnection, disregarding this parameter value.

To modify the DTR line behavior on port disconnection;

- press [8],
- then [H] or [L] or [P] respectively.

3.1.3.1.8 Inter-character delay

An inter-character delay (1 - 60 ms) may be defined, each time a character sequence is transmitted from the port. Using this command, a minimum pause will appear between transmitted characters; for example, certain types of electro-mechanical devices (like teletype equipment) cannot process received characters continuously at their specified baud rate.

To select an inter-character delay;

- press [8],
- enter the new value (0 for no delay),
- and press [Enter] to save it, [Esc] or [Space] to cancel.

FYI: This parameter is not available for port 0.

3.1.3.1.9 Line-break receive or transmit

It is possible to accept the line-break received from a port, and to send it from the connected port. The break condition (when received) is defined as zero data with zero parity and no stop bits.

To allow or not the line-break receive;

- press [9],
- then [Y] for allowed,
- [Esc] or [Space] to cancel, any other character to deny.

To define the transmitted line-break extra-duration (this is added to the 1-character transmission time);

- press [0],
- then enter the new value (1 - 999 ms) or 0 to disable it,
- and press [Enter] to save it, [Esc] or [Space] to cancel.

FYI: These parameters are not available for port 0.

3.1.3.1.10 Copy Port Serial Settings

- Press [+] to select the current port as source in a port settings copy-paste process (except port 0).
- Then, press [*] to paste the port settings.
- Press [Y] to paste the selected port settings to the current port, [A] to paste to all ports, [S] to specify the destination port, or press any other key to cancel.

3.1.3.1.11 Display serial settings for different port number

Press [>] (greater than symbol) to display the next higher port serial settings, or press [<] (less than symbol) to display the previous port serial settings.

Press [Esc] or [Space] to return to the "Port settings" menu.

3.1.3.2 Modem settings

From the "Port settings" menu, press [6] to display the "Modem settings" menu.

Remote connections are possible if modems are used, usually by the users. The remote modem may call in to a local modem attached to a SERIMUX port. A minimum number of port modem settings can be adjusted in the SERIMUX to control the connection (try the default values first; refer to the manual(s) for the modems otherwise).

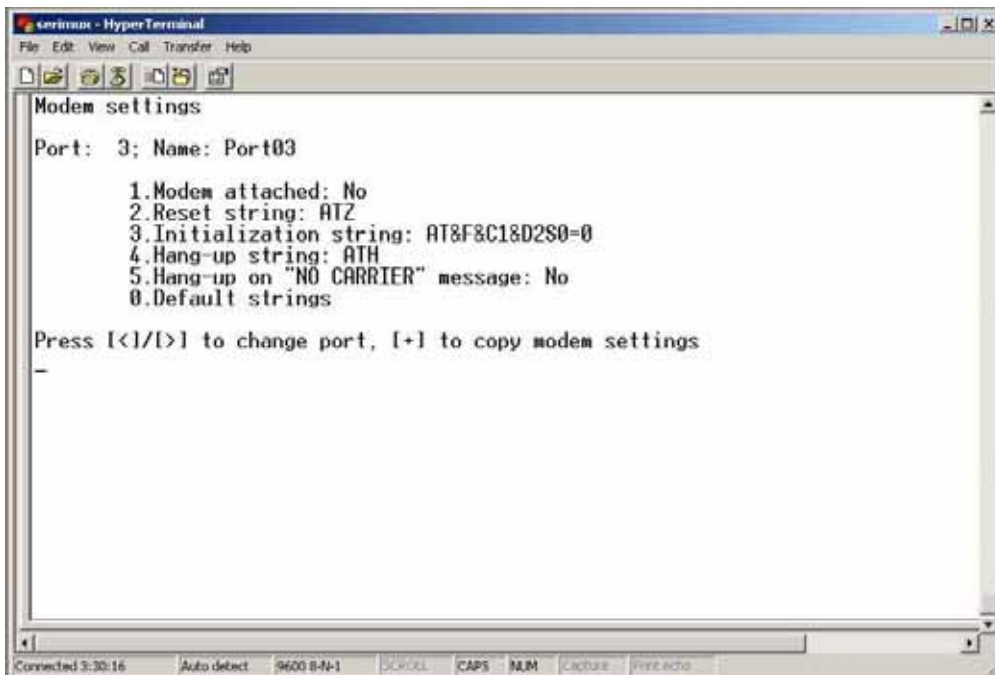

Figure 12- Modem settings menu

The administrator can initialize a modem attached to a SERIMUX port, or disconnect the modem. To control the modem connection from the "Modem settings" menu, the following functions are possible:

Function	Keystroke
Attach and initialize a modem	[1] - [A]
Disconnect a modem	[1] - [D]
Change the modem reset string	[2]
Change the initialization string	[3]
Change the hangup string	[4]
Enable hangup on "NO CARRIER"	[5]
Save the changes	[Enter]
Cancel the command	[Esc]
Reset to default values	[0]-[Y]

FYI: If an old modem is attached to a SERIMUX port, it may be necessary to enable the "Hang-up on "NO CARRIER" message" option, in order to hang-up and disconnect the attached modem when receiving this message. Press [5], then [Y] to enable or any other key to disable this option. Usually, this option should remain disabled.

- Press [+] to select the current port as source in a port modem settings copy-paste process (except port 0).
- Then, press [*] to paste the port settings.
- Press [Y] to paste the selected port settings to the current port, [A] to paste to all ports, [S] to specify the destination port, or press any other key to cancel.

Display modem settings for different port number

Press [>] (greater than symbol) to display the next port (next higher port index) modem settings, or press [<] (less than symbol) to display the previous port modem settings.

Press [Esc] or [Space] to return to the "Port settings " menu.

3.1.3.3 Port data buffer

From the "Port settings" menu, press [7] to view the port data buffer. In this display the administrator can see the last 1016 characters received and transmitted to/from any port. This way the administrator can verify that data was transferred properly between ports.

```

serimux - HyperTerminal
File Edit View Call Transfer Help

Port data buffer

Port: 2; Name: Port02

Received characters:
FF80: 00 00 ED 38 5C 4F 41 F9 00 01 1E C2 4E B9 00 00 ...8\0A. ....N...
FF90: 29 30 41 F9 00 01 1E 00 4E B9 00 00 29 30 13 FC )0A..... N...)0..
FFA0: 00 3D 00 21 12 A8 60 00 2E 5E 0C 03 00 20 67 00 .=.!...' ^....g.
FFB0: EB BE 0C 03 00 1B 67 00 EB B6 0C 03 00 31 67 1E .....g. ....1g.
FFC0: 0C 03 00 32 67 18 4A 39 00 21 12 6C 67 00 2E 38 ...2g.J9 !.lg..8
FFD0: 0C 03 00 41 67 08 0C 03 00 42 66 00 2E 2A 10 03 ...Ag... .Bf...*.
FFE0: 4E B9 00 00 2A 46 70 00 10 03 04 80 00 00 00 31 N...*Fp. ....1
FFF0: 67 10 53 80 67 10 51 80 5F 80 0D 32 60 1B 20 0D g.S.g.Q. ...2' .

Transmitted characters:
FF80: 74 69 6E 67 73 0D 0A 09 36 2E 55 73 65 72 20 64 tings... 6.User d
FF90: 69 73 63 6F 6E 6E 65 63 74 2F 6C 6F 67 6F 75 74 isconnec t/logout
FFA0: 0D 0A 09 37 2E 41 64 76 61 6E 63 65 64 20 73 65 ...7.Adv anced se
FFB0: 74 74 69 6E 67 73 0D 0A 09 39 2E 52 65 74 75 72 ttings.. .9.Return
FFC0: 6E 20 74 6F 20 75 73 65 72 20 6D 65 6E 75 0D 0A n to use r menu..
FFD0: 09 30 2E 4C 6F 67 6F 75 74 0D 0A 0D 0A 0A 44 69 .0.Logou t....Di
FFE0: 73 63 6F 6E 6E 65 63 74 69 6E 67 20 61 64 6D 69 sconnect ing admi
FFF0: 6E 69 73 74 72 61 74 6F 72 20 6E 6F 77 0D 0A 0A nistrato r now...

Press [<]/[>] to change port, [N]/[P]/[R] to see next/prev./refresh page

Connected 4:18:25 Auto detect 9600 8-N-1 SCROLL CAPS NUM Capture Print echo

```

Figure 13- Port data buffer

Press [P] to see the previous (older) 128-character page information; press [N] to see the next (newer) 128-character page information.

Up to 1016 received characters and 1016 transmitted characters (8 pages) can be inspected, for each port.

Press [>] (greater than symbol) or [<] (less than symbol) to change the current port.

Press [Esc] or [Space] to return to the "Port settings " menu.

FYI: Only the "ROOT" administrator is able to access the port data buffer.

3.1.4 User List

From the administrator main menu, press [4] to display the User list.

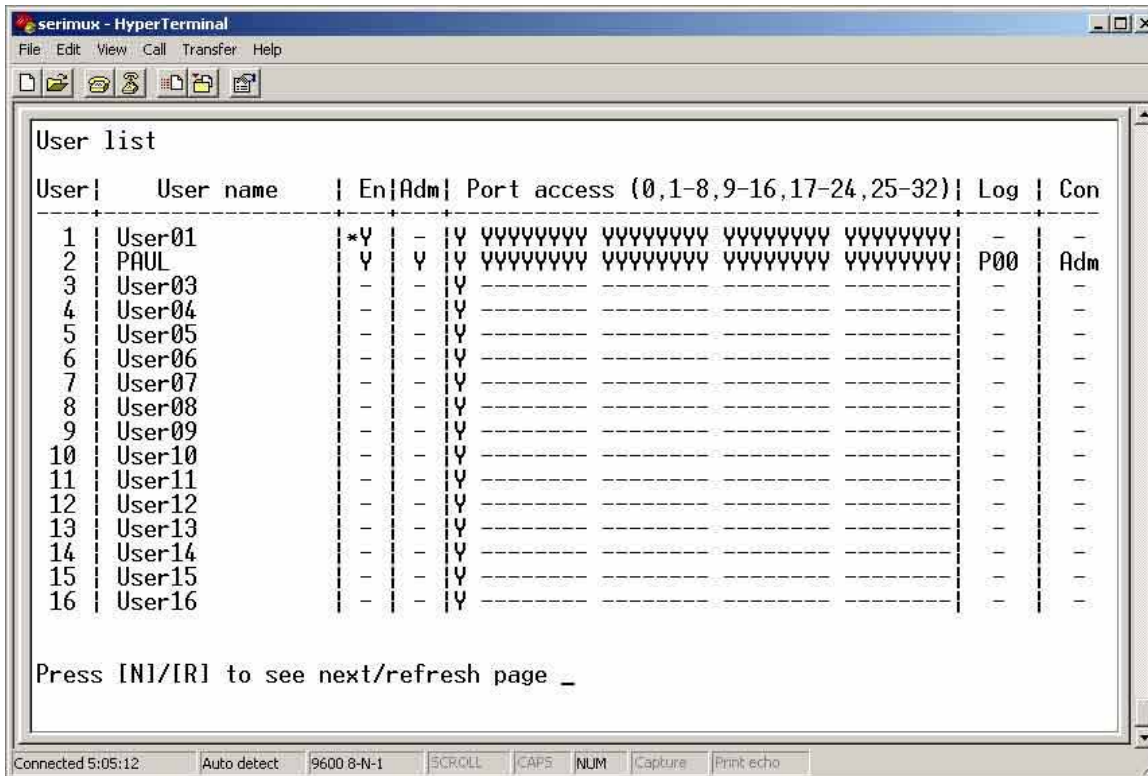

Figure 14- User List

Column Heading	Description
User	User Index number
User Name	User name associated with the index number
En	User status- "Y" = enabled " - " = not enabled
Adm	Displays if user has administrative rights "Y" = yes " - " = no
Port access	Displays what ports the user has access to
Log	Identifies what port the user is logged into, if any
Con	Identifies what port the user is connected to (Pxx) Or if the user is logged in as an administrator (Adm) Or if the user is just logged in (Usr)

- Press [R] to refresh the information and repaint the screen.
- Press [N] to see the next page; press [P] to see the first page.
- Press [Esc] or [Space] to return to the "Administrator main menu".

3.1.5 User Settings

From the "Administrator main menu", press [5], enter the user index number, then press [Enter]. The screen will show the current user number and name and the user settings menu:

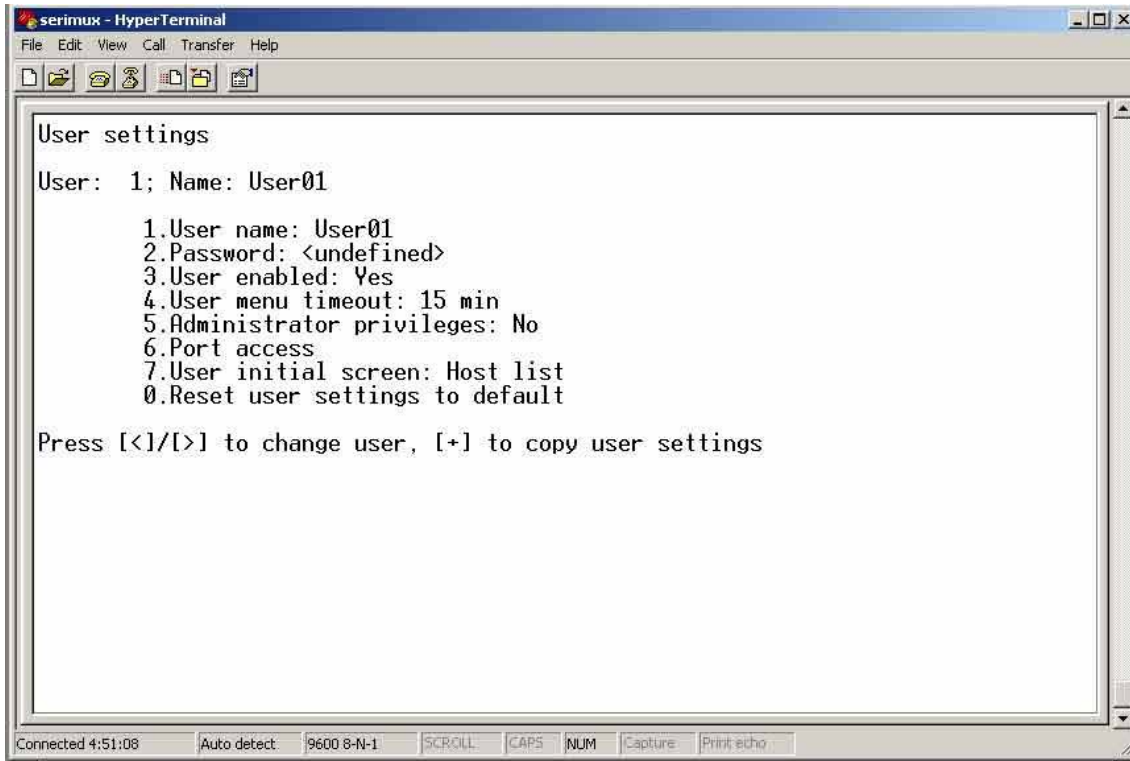

Figure 15- User settings menu

Setting	Description	Value
User name	Change the user name	Max. 15 characters, use backspace to delete
Password	Define the user password, if any	Max. 31 characters, use backspace to delete
User enabled	Enable or disable user	Y to enable, any other character to disable
User menu timeout	Time interval of user inactivity before auto logout of the user will occur	0-90 minutes 0 = never
Administrator privileges	Enable administrative privileges for user	Y to enable, any other character to disable
Port access	Define ports user has access to. Displays user's Port access list (Fig.16)	1 + port number to grant access to a port 0 + port number to deny access to a port < or > to change to different user access list
User initial screen	Select the initial user menu to display upon user login	M = User main menu H = Accessible host list T = Terse mode
Reset user settings to default	Restores factory default user settings	A confirmation "Y" will be required

- When selecting each new user setting values, press [Esc] or [Spacebar] to cancel, or press [Enter] to save.
- Press [>] to display the current settings for the next port.
- Press [<] to display the current settings for the previous port
- Press [Esc] or [Spacebar] to return to the Administrator main menu

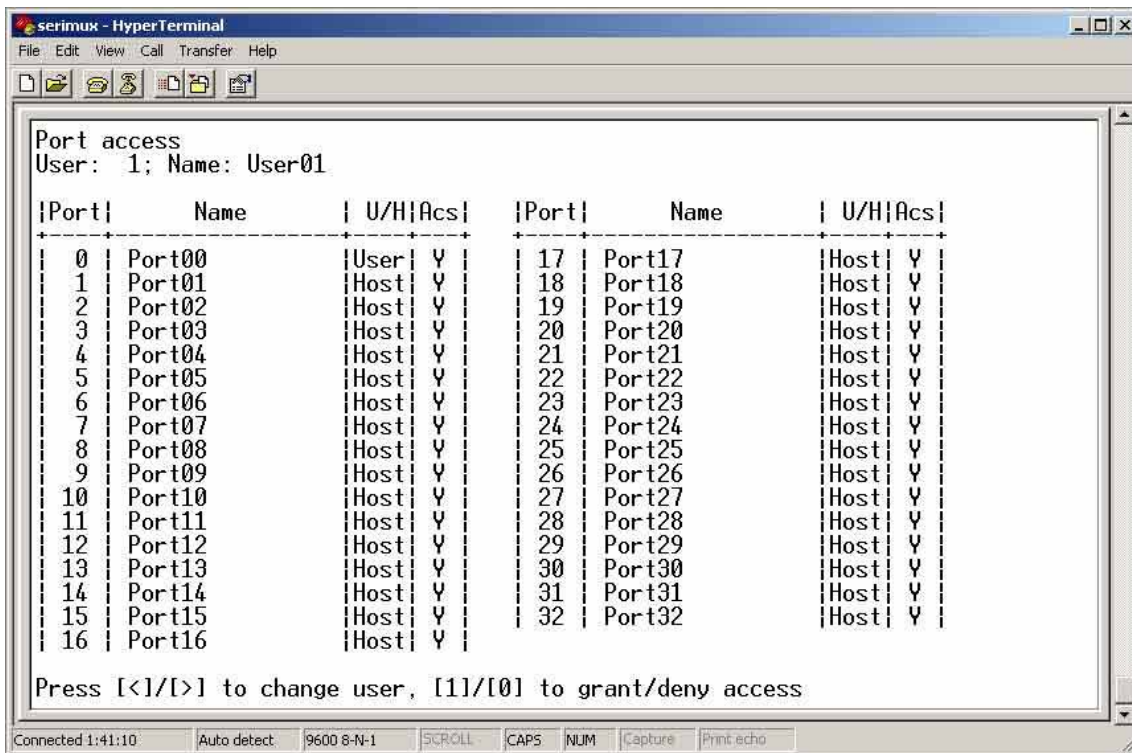

Figure 16- Port access list for User 01

3.1.5.1 Port access

To quickly grant/deny user access to multiple ports, the use of a dash (-) and/or comma may be used in conjunction with the [1] (to grant) or [0] (to deny) command.

i.e. [1] - [1-4,7,9,15] will grant access to ports 1 through 4, 7, 9, and 15, all in one command string

3.1.5.2 Copy User Settings

From the User settings menu,
 press [+] to copy the current user's user settings to memory
 press [*] (asterisk) to start the paste function. Three options are available:

Option	Description
Y	apply the settings in memory to the current user shown
A	apply the user settings in memory to all users
Sxx	where xx is 01-16- apply the user settings in memory to a specific user

The "Y" option is particularly useful if the administrator wants to place a particular user's settings into memory and move around to other users (using the [<] or [>] keys) to review their settings before pasting the settings into memory over them.

The "S" option will allow the administrator to paste settings into memory to a specific user without having to view that user's settings list.

3.1.6 Advanced Settings

From the "Administrator main menu", press [7] to display the "Advanced settings" menu.



Figure 17- Administrator's Advanced settings menu

From the "Advanced settings" menu the administrator can perform the following functions:

Setting	Description	Value
Administrator Password	Define the password to be used by the administrator	Max. 31 characters. This can only be changed if old password is known. (If SERIMUX is re-initialized, the password will change back to 'NTI')
Administrator Timeout	the time interval of administrator inactivity, prior to logging out.	0-90 minutes 0 = Never
Unit name	Name assigned to the SERIMUX	Max. 40 characters
User to auto login	User assigned to automatically login at power up without a password.	Index number of any enabled user that has access to the port being used for the user port
Connect two host ports	Connect two host ports together	Enter host port index number, press [Enter], second host port index number, and press [Enter] again
Firmware	Display the firmware menu	See pg. 24

FYI: If at powerup the auto-login user does not have access to port being used, a login by a valid user with access rights will be required.

3.1.6.1 Change administrator password

For security purposes the administrator should change the factory default administrator password to a unique password. This will prevent unauthorized access to switch functions and CPUs. The password is needed to log in from any device, connected to any SERIMUX port in buffer mode.

To change the administrator password, from the Administrator main menu;

- press [7] to choose Advanced settings and press [Enter]. The Advanced settings menu will appear (Fig. 17)
- press [1] and a prompt for the old password will appear
- enter the old password (factory default password is "NTI") and press [Enter]
- enter a new password (maximum 31 ASCII characters), using the [Backspace] key to erase any characters entered in error, and press [Enter]
- re-enter the password to confirm it, and press [Enter]
- a message "OK" will appear, press any key to return to the Advanced settings menu

NOTE: The password entered will be case sensitive so be sure to note what characters are used and what case they are in if any are alphabetical. The password characters are displayed as "*" (asterisk) characters while entering them.

NOTE: If the administrator password is not known, the administrator must re-initialize the SERIMUX following the "Initialize SERIMUX Console Switch to default settings" instructions on page 26.

3.1.6.2 Firmware

From the Advanced settings menu, press [6] to display the Firmware menu. (From Administrator main menu press [7]-[6])

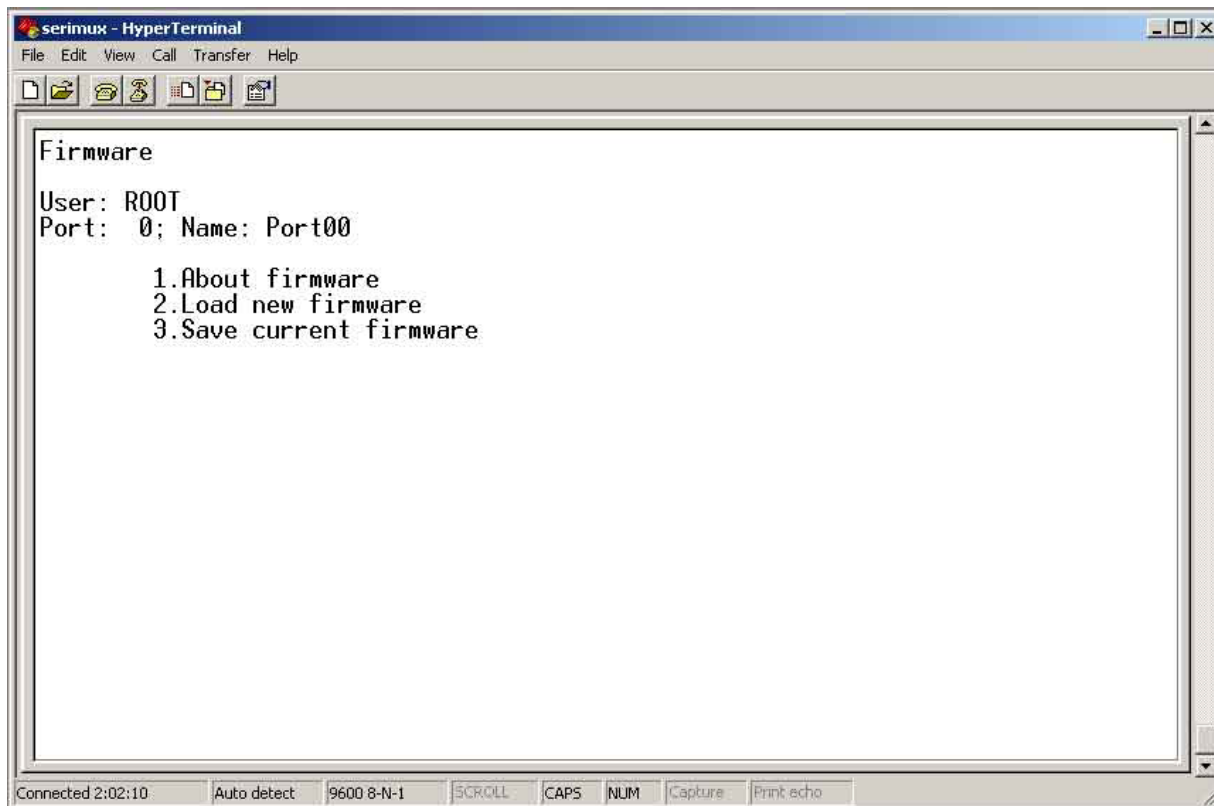

Figure 18- Firmware menu

The Firmware menu has three possible functions:

Function	Description
1. About Firmware	Provides information about SERIMUX including revision number, code length, and CRC
2. Load new firmware	Initiate firmware upgrade (not available at this time)
3. Save current firmware	Save present firmware in SERIMUX to binary file

3.1.6.2.1 Load new firmware

To upgrade the firmware that controls the Console Switch, as soon as improved versions become available, download the firmware file (from the NTI website at www.networktechinc.com) to a local CPU, and follow the instructions under "Firmware Upgrade" to install it.

Note: *Firmware upgrades are not available as of this publication.*

3.1.6.2.2 Save current firmware

In order to save the firmware currently in SERIMUX, from the Firmware menu:

press [3] for Save current firmware. The message shown in Fig.19 will appear.

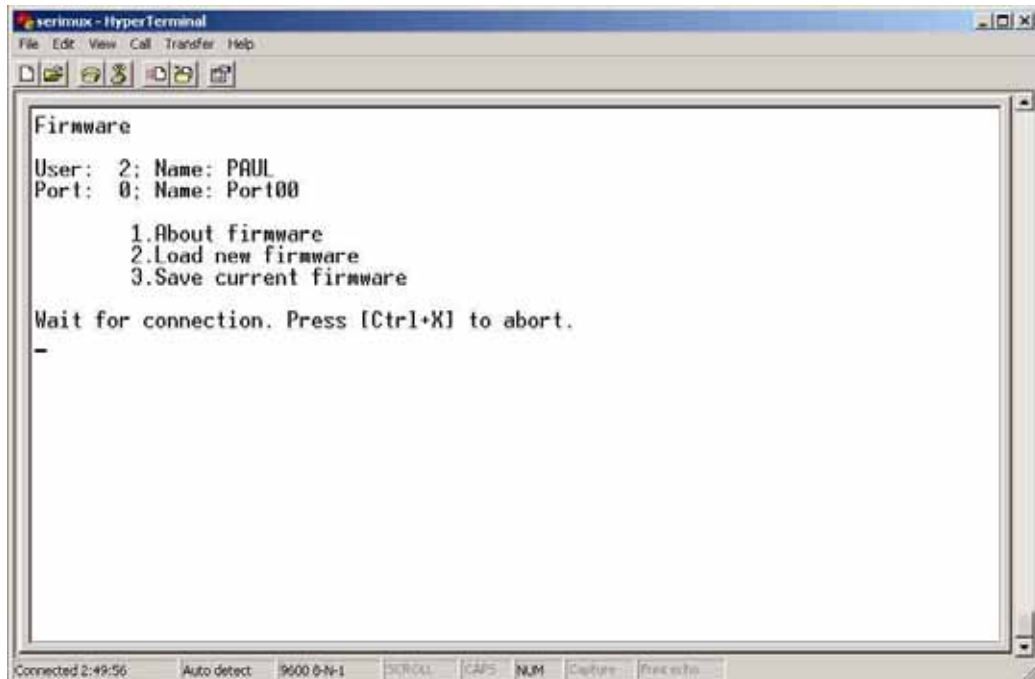

Figure 19- The SERIMUX is waiting to save its firmware

Using the terminal program, configured for Xmodem protocol, receive the binary file (for example the HyperTerminal for Windows Transfer -> Receive File command) to transfer the SERIMUX firmware to a binary file. When saving the file, choose a directory to place the file in and a name that will identify it with the extension ".bin" (i.e. SERIMUX1_8.bin). With the file saved, it can be restored to the SERIMUX at any time if desired.

3.2. User Controls

Users can connect only to accessible ports as defined by the administrator. A list of those ports will be displayed with a successful login. Connection can be made using the TERMINAL, or a serial terminal with an emulator (e.g. Windows HyperTerminal) connected to the SERIMUX at an allowed user port

To login, press the [Spacebar] or [Enter] key. Users can login by entering a valid name and password, assigned by the administrator. When prompted for a "User name:", type the administrator assigned user name and press [Enter]. When prompted for the "Password:", type the administrator assigned password and press [Enter].

Note: *User names and passwords are case sensitive. It is important to know what characters must be capitalized and what characters must not.*

FYI: *The administrator may select a user that will automatically login at power up (User 1 is setup by default). In this case, neither name nor password will be required, just press [Spacebar] or [Enter] after power ON the TERMINAL or opening the connected terminal emulator.*

After login, the user may connect to an allowed host port, or view host status and parameters. The user is unable to modify port parameters unless the user has been granted administrative privileges.

3.2.1 User "Accessible host list" screen

After successful login, the "Accessible host list" will be displayed. The administrator may choose another initial screen to be displayed, following user's preferences. The Accessible host list includes:

- user index number and name
- index number and name of the login port
- index numbers and names of accessible hosts

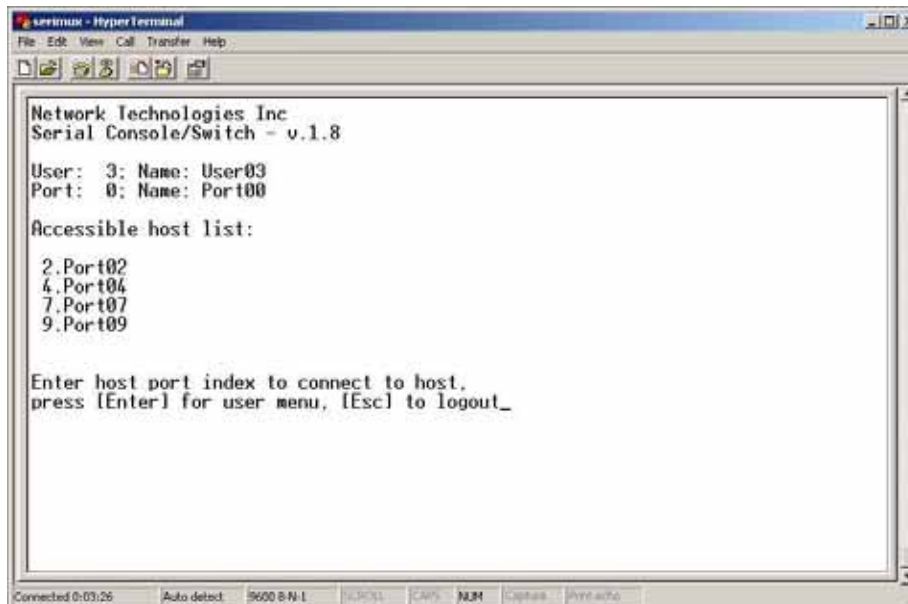

Figure 20- A user with limited host port access

From the "Accessible host list", the user can perform the following functions:

Function	Keystroke
Connect to host	[xx] - [Enter] (where xx is the port index number)
Refresh the screen	[Spacebar]
Logout	[Esc] or [Ctrl]+[X] , then [Y] to confirm

FYI: *The port index numbers are 2-digit decimal numbers. If the wrong number is entered, simply enter the correct number. Only the last two numbers entered before the [Enter] key is pressed will be accepted. The [Enter] key validates the command; [Esc] or [Spacebar] cancels it.*

3.2.2 User main menu

The User main menu includes:

- user index number and name
- index number and name of the login port
- user command list

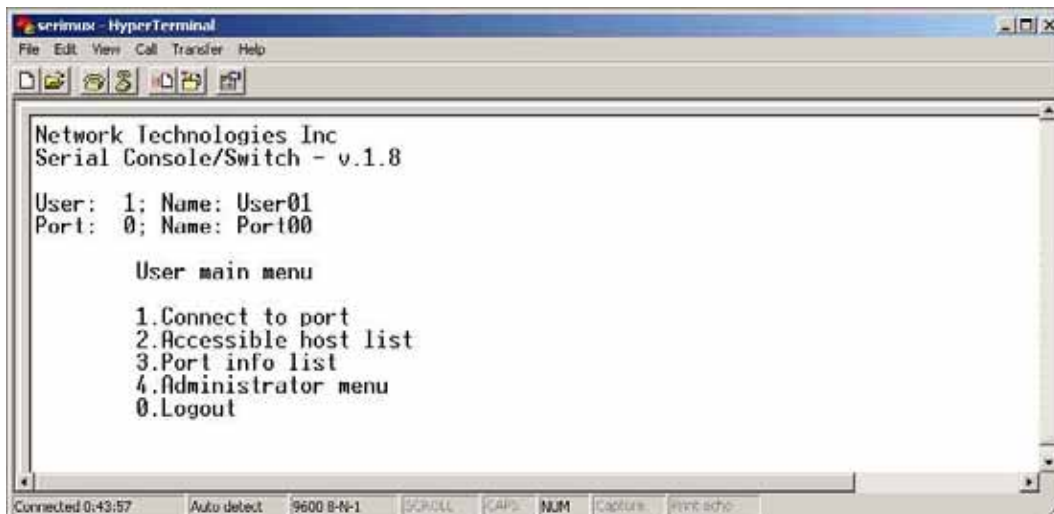

Figure 21- User main menu

From the "User main menu" the following functions are possible:

Function	Keystroke
Connect to host port	[1]-[xx]-[Enter] (where xx is the port index number)
Display Accessible host list	[2]-[Enter]
Display accessible host and user ports and info about each	[3]-[Enter]
Login as administrator	[4]-[Enter] (only works if user has administrative rights)
Logout	[0] then [Y] to confirm
Refresh the screen	[Spacebar]

A user can only connect to the hosts the user has been allowed access to by the administrator. Press [2] to display a list of accessible hosts.

3.2.3 Port List screen

From the "User main menu", press [3] to display the list of user accessible ports and information about these ports. Only the administrator can change the communication settings.

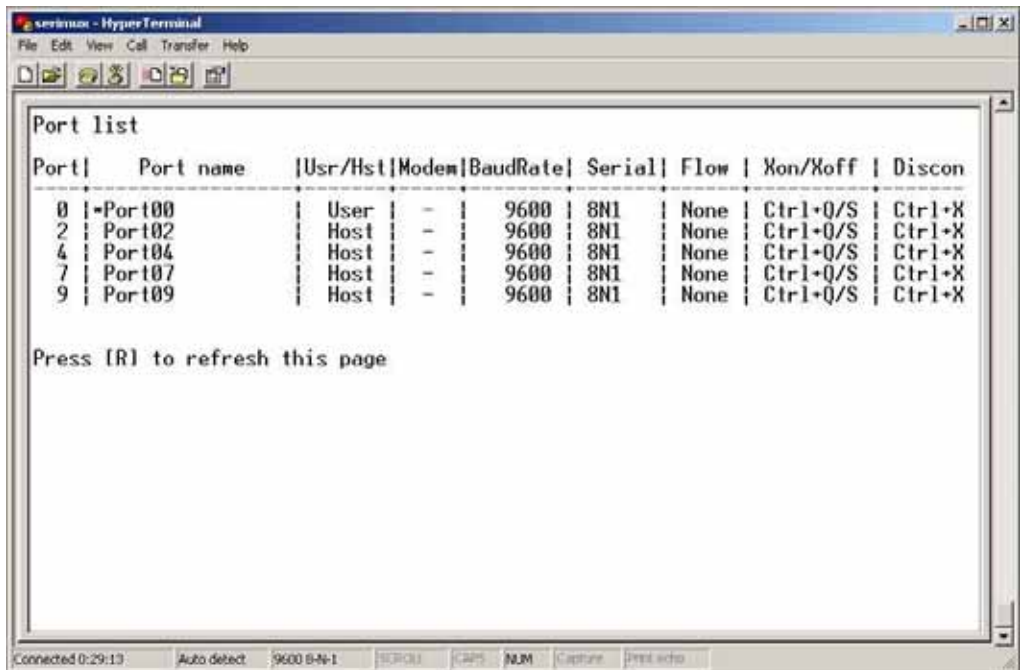

Figure 22- A limited user accessible Port list

On consecutive columns, the following are displayed:

Column	Description
Port	index number of the port
Port Name	Name assigned to the port
Usr/Hst	Port type, user or host
Modem	Yes if modem is attached, - if not
BaudRate	Receiving and transmitting speed of the port
Serial	Character size, parity, and stop bit number
Flow	Defines flow control method <ul style="list-style-type: none"> • Hard (RTS/CTS or outband) • Soft (Xon/Xoff or inband) • Both • None
Xon/Xoff	Characters used for Xon and Xoff flow control
Discon	In-band disconnect sequence (1-3 characters, or none)

Press [R] to refresh and re-display the information on the screen.

If the number of user accessible ports is greater than 17,
 press [N] to see the next page,
 press [P] to see the first page.

Press [Esc] or [Space] to return to the "User main menu".

3.2.4 User Terse mode

This mode is especially useful when the SERIMUX is directly controlled by external software from a serial console (as a user without administrative privileges), rather than being controlled by a user from a keyboard interface.

Entering short command strings performs functions similar to the user main menu commands. A [CR] – [LF] sequence ends every string. The commands are not echoed; the SERIMUX returns to the serial console a specific answer if the command is successfully accomplished or an error message otherwise.

Terse mode can be used only if the administrator configures a user port to enter into Terse mode at login. If a keyboard-based user logs into a port intended for Terse mode operation, the following image will appear:

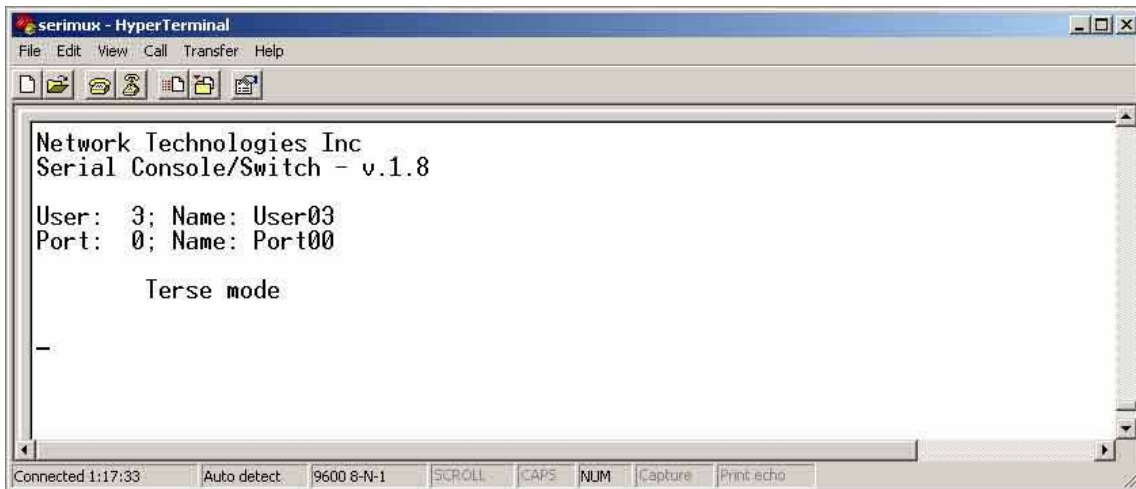

Figure 23- User port in Terse mode

From Terse mode, a limited number of functions are possible;

3.2.4.1 Terse mode commands

> Connect to port

Send or type in:

[C] **xx** [Enter]

where **xx** is the port index number. The answer will be:

OK [CR][LF][LF][FF]

If an error occurs (i.e. the port is not accessible), the answer will be:

Err [CR][LF]

> Accessible host list

Send or type in:

[H] [Enter]

The answer may be, for example:

02,03,04,05,06,07,08,09,10,11,12,13,14,15,16 [CR][LF]

(the accessible hosts, separated by commas)

> Port info

Send or type in:

[P] **xx** [Enter]

where **xx** is the accessible port index number. The answer may be, for example:

04,H, 9600,8N1 ,N,QS,1X [CR][LF]

where the comma separated fields stand for:

- port index number;
- port type: U or H for User or Host;
- port baud rate;
- data bits (5..7), parity (N, E, O for None, Even, Odd), stop bits (1, 1.5, 2, 2.5);
- flow control (N, H, S, B for None, Hard, Soft, Both respectively);
- in-band (soft) flow control Xon and Xoff characters (in this example Xon = [Ctrl+Q] and Xoff = [Ctrl+S]);
- disconnect sequence length and sequence (i.e. "0 " for none, "1X " for 1-char [Ctrl+X] sequence, "3"" for 3-char "" sequence);

If the port is not accessible to the user, the answer will be:

Err [CR][LF]

➤ **Verbose mode**

Send or type in:

[V] [Enter]

The answer will be:

OK [CR][LF]

and the Terse mode will be terminated. The “Accessible host list” or the “User main menu” will be displayed.

Note: Once a user configured for Terse mode login exits Terse mode to enter Verbose mode, Terse mode login will no longer be available at login. To return to Terse mode, the administrator must re-configure the user settings to enter Terse mode at login.

➤ **User Logout**

Send or type in:

[L] [Enter]

The answer will be:

OK [CR][LF]

With the next login of the same user, Terse mode will resume.

FYI: Buttons pressed in sequence on the keypad to enter commands must be pressed within 5 seconds of each other for the SERIMUX to respond. Otherwise, the sequence will need to be repeated from the beginning.

➤ **Login the administrator**

Note: In order to login the administrator to a port other than port 0, the administrator must first configure the desired port as a user port (see page 15). By default, all ports, other than 0, are configured as host ports.

3.2.5 Initialize SERIMUX Console Switch to default settings

SERIMUX can be reset to default settings by using the "RESET" button

The RACKMUX should be OFF before pressing the "RESET" button.

1. Press and hold the "RESET" button using a small object that will fit through the hole in the back of the SERIMUX. (See Fig. 21).
2. Turn ON the RACKMUX.
3. Wait 3 seconds.
4. Release the button.

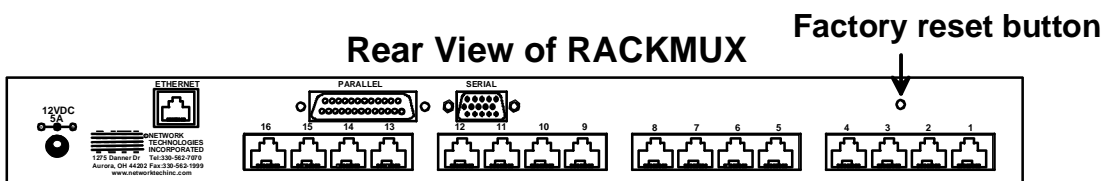

Figure 24- Location of RESET button

Caution: During initialization, the customer modified parameter values will be replaced with the factory default values (for default values, see Table 2, page 31), user names and passwords will be erased.

Every port is defined through the following parameters:

Table 2- SERIMUX Port Characteristics

Description	Acceptable Value	Default Value
Number	0-8/16/24/32	Same (not changeable)
Name	Up to 15 characters	"Port00" to "Port32"
Type – port 0	User	User (not changeable)
Type – except port 0	User or Host	Host
Baud rate – port 0	300-115200	9600
Baud rate – except port 0	50-128000	9600
Data bits per character – port 0	7,8	8
Data bits per character – except port 0	5,6,7,8	8
Stop bits – port 0	1, 2	1
Stop bits – except port 0	1, 1-1/2, 2, 2-1/2	1
Parity	No parity, even, odd	No parity
Handshake mode (flow control)	Xon / Xoff (or in-band, or software), RTS/CTS (or out-band or hardware), Both, None	None
Xon character	any ASCII nonprintable character (0-31 range)	Ctrl+Q (17)
Xoff character	any ASCII nonprintable character (0-31 range)	Ctrl+S (19)
Inter-character delay – except port 0 (no delay allowed on port 0)	1-60 milliseconds, none	None
Line break receive allowance – except port 0 (no allowance for port 0)	Yes or No	No
Transmitted line break extra duration (added to 1 character transmission time) – except port 0 (no extra duration for port 0)	No break transmitted, 1-999 milliseconds	No break transmitted
In-band disconnect sequence	0 (disabled), 1, or 3 characters sequence	1-char sequence
1 character disconnect sequence	Any ASCII nonprintable character (0-31 range)	Ctrl+X (24)
3 character disconnect sequence	Any 3 ASCII characters	``` (3 back quotes)
Connection timeout	1-90 minutes, never	15 minutes
DTR output upon disconnect	Low, high, or pulsed for 0.5 seconds and then held high	High
Modem Reset string	Up to 41 characters	ATZ
Modem Initialization string	Up to 41 characters	AT&F&C1&D2S0=0
Modem Disconnect string	Up to 41 characters	ATH

4. USING THE TERMINAL

4.1 How To Setup The TERMINAL

The TERMINAL is compatible with most CPUs and application packages. A menu driven setup system is provided to select and save the settings required by the CPU and application. To control the CPU, or in this case the SERIMUX, a user must be familiar with the requirements of the SERIMUX in order to setup the TERMINAL.

4.1.1 Entering TERMINAL Setup

Hold down the <ALT> key and then depress the <Esc> key to enter Setup mode. When entering Setup, any text on the screen temporarily disappears, and the main SETUP directory appears (See Figure 25). When leaving the Setup mode, the main SETUP directory disappears, and any text that was on the screen will reappear.

4.1.2 Saving and Exiting Setup

The first menu seen when entering Setup serves as a directory to the other Setup menus. To exit Setup or any submenu, press <F12>. Pressing <F12> will return the display to the main Setup directory and with another press of <F12> the user will exit Setup.

The highlighted field at the right of the screen gives the user the choice of saving or not saving parameter changes into memory before returning the terminal to the normal operating mode. Settings changed will effect the operating environment until the TERMINAL is powered-down. Setting changes will only be restored at power-up if they are saved before exiting Setup.

NOTE: If settings are not saved before exiting Setup, any new selections will be lost when the RACKMUX is powered-down.

To save Setup selections, depress the Spacebar to change the save field at the right side of the screen from NO to YES before exiting Setup. (Table 3 describes your options for exiting Setup.)

Depress <F12> to leave Setup and return to the normal display mode.

Table 3- Main Setup Menu (F12) Exit Functions

Option	Function
No	Returns terminal to normal operating mode without saving parameters changes for power up
Yes	Saves all changes (operating parameter, tabs, key definition, and answerback message); returns terminal To its normal operating mode.
Shift + Esc	Restores all setting (operating parameters, tabs, key definitions, and answerback message) to their factory default values.

4.1.3 Setup Directory

The fields at the bottom of the screen show the various setup menus where the terminal's operating parameters can be changed and the function key to press to immediately display any menu.

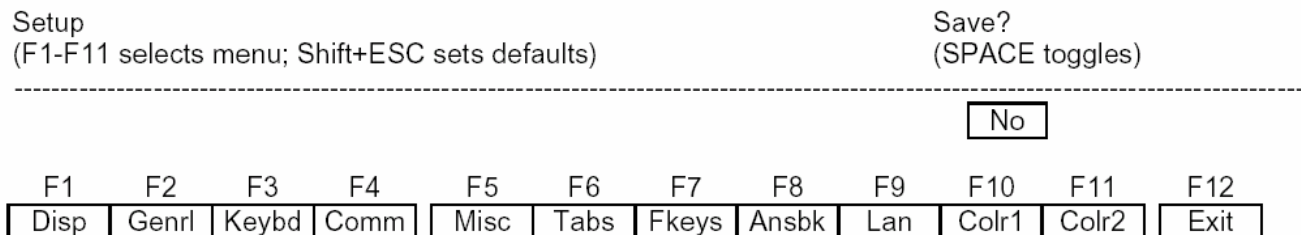

Figure 25- Fields in the Setup menu display which function keys to press for submenus

4.2 Changing The TERMINAL Operating Parameters

To select one of the setup menus shown, press the indicated function key.

- The screen for that menu appears with the name highlighted.
- The fields at the middle of the screen indicate the parameters that can be changed in that menu.
- The top line identifies the keys to press to highlight the parameter fields and change the settings.

The procedure is: (1) Use arrow key to highlight the parameter field to be changed.

(2) Use the Spacebar to change the parameter.

<F12> always returns the user to the top menu.

The following tables list the parameters for each menu and explain their settings. Default settings are listed first unless otherwise noted.

F1- Disp SETUP Menu

Columns sets the screen display for 80 columns, 132 columns, or Econ-80 (80 columns with more pages of memory).

Lines sets the screen display for 24, 25, 42, or 43 lines. (24 lines are normally required for VT emulation, 25 lines for PC Term.)

Auto Page on causes a new page of memory to move onto the screen when the cursor reaches the top or bottom of the page.

Display CRT/LCD selects which kind of monitor be used. If LCD monitor is selected, the display columns only support 80 columns on Econ-80 columns. Must be set to LCD.

Cursor sets the cursor display to blink or steady, block or underline.

Background sets the screen display to Dark (light chars. on a dark background) or Light (dark chars. on a light background).

Width Change Clear causes the terminal to clear the screen when executing a command to change the number of columns.

Screen Saver OFF, 1, 2, 3, 4, 5, 6. Sets the screen saver to activate after the specified number of minutes.

Page Length sets the length of a page of display memory to:

- 1 x Lines: Equal to the number of lines selected in the lines parameter (this value must be set when using multiple sessions)
- 2 x Lines: Two times the value of the lines parameter
- 4 x Lines: Four times the value of the lines parameter, or
- *: Equal to the value of the lines parameter, with a second page containing the rest of the lines remaining in memory.

ANSI Reverse OFF/ON. Control function ANSI, VT-100 and VT-220:

- "OFF" means, when SGR command ESC [3? m and ESC [4? m select background and foreground color change respectively.
- "ON" means, when SGR command ESC [3? m and ESC [4? m select foreground and background color change respectively. (?)
- can be 0,1,2,...,7)

F2- Genrl SETUP Menu

Personality sets the terminal's operating mode to Wyse 325, Wyse 120/Wyse 60 (native mode), Wyse 50+ (WY-50, WY-50+, WY-100, ADM 31/5/3a), TeleVideo TVI 925, TVI910+ (includes 910), ADDS A2, Digital Equipment VT-100, VT-220 7 bits, VT-220 8 bits, VT-52, Console ANSI, PC TERM, PCG Alpha.

Scroll Speed sets the display scroll rate to Jump (the rate data is received), Smooth-8 (eight lines per second), Smooth-4, Smooth-2, or Smooth-1.

Rcvd CR causes the cursor to move to the beginning of the current line (CR) or the beginning of the next line (CRLF) when the terminal receives an ASCII CR.

Enhance allows the terminal to recognize an enhanced set of codes when the terminal is not in the native personality.

Auto Scroll causes the data to scroll up a line when the cursor moves past the last line of the page.

Monitor causes the terminal to display symbols for escape sequences and control codes without acting on them (test feature).

Status Line sets the top line of the screen as the status line.

End of Line Wrap causes the cursor to move to the start of the next line when additional characters are entered at the end of a line.

Attribute sets display attributes to be assigned to each character as it is entered (Char), to be active to the end of the line (Line), or to be active to the end of the page (Page).

F3- Keybd SETUP Menu

Keyclick sets the terminal to sound a muted beep each time a key is pressed or repeated.

Margin Bell sets the terminal's bell to ring when the cursor reaches the column where the bell is set (default is column 72 in 80-column mode or 124 in 132-column mode).

NRC ON/OFF determines the communication and keyboard national character set.

DEL Keypad Dot/Del or Comma/Del. Determines whether numlock DEL generates dot or comma.

Key Repeat OFF, 1, ..., 8. Defines key repeat rate after a key has been depressed for about 1/2 second.

Language sets correct terminal operation for the language of the keyboard connected to it: US, UK, Danish, German, Spanish, Swedish, Norwegian, Italian, French, Belgian, Swiss/French, and Swiss/German. Should be set to US.

Bell Volume OFF, 1, 2, 3 (3 different volumes)

Limit Xmt causes the terminal to send data through the HOST port as fast as the baud rate allows (None), or at a maximum rate of 60 cps or 150 cps. In older systems limiting character rate is necessary to prevent loss of data.

Key Code sets the terminal to send normal ASCII characters (ASCII) or PC-type scan codes for every key up / down (Scan). Scan is only required for the PC Term personality.

Num Start ON/OFF. When the terminal powers ON, this field determines whether the numeric pad starts as Numeric (NUM ON) or Function (NUM OFF).

F4- Comm SETUP Menu

Baud Rate sets the host port baud rate to 50, 110, 134.5, 200, 300, 600, 1200, 2400, 4800, 7200, 9600, 19200, 38400, 57600, 76800, or 115200.

Rcv Hndshake allows the terminal to control the receipt of data from a device connected to the SERIAL1 port with no handshaking (None), Xon / Xoff handshaking, DTR handshaking, DTR / Xoff handshaking

XPC Hndshake ON/OFF to set XPC code handshake, only possible when the personality parameter is set to PC Term.

Ethernet Mode ON/OFF to set the communication routing by Ethernet Network / or Serial Port.

Data / Stop Bits through the SERIAL1 port, the terminal to send and receive 8-bits data with one stop bit or two stop bits, or 7-bits data with one stop or two stops bits.

Xmt Handshake causes the terminal, when sending data to a device connected to the SERIAL1 port, to ignore all incoming software handshaking signals (None) or to control data output in responds to Xon/Xoff handshaking.

Printer

Parallel : sends data to a parallel printer connected to the parallel port.

Serial : sends data to a serial printer connected to the serial 2 port.

OFF : ignores the print command.

Auto Connect OFF/ON selects whether a return character is required to establish an Ethernet connection.

Parity sets the terminal send data to the SERIAL1 port with none, odd, mark, even, or space parity.

Comm Mode sets the SERIAL1 port communication mode to full duplex (FDX), block (BLK), half duplex (HDX), or half duplex block (HBLK).

Multiple Sessions defines whether an Ethernet connection supports multiple sessions function.

ON : indicates the terminal supports multiple sessions. Each session only has one display page. In 80 or 132 column mode, 8 simultaneous sessions are supported. In Econ-80 column mode, 12 simultaneous sessions are supported.

OFF : indicates the terminal only has single session. In this mode page length greater than one page can be defined.

F5- Misc SETUP Menu

Wprt Intensity sets the write protect attribute: normal, blank, dim, blank/dim.

Block End causes the terminal to send a block of data to the CPU with a line terminator as an ASCII US character and block terminator as an ASCII CR character (US / CR), or with line terminators as ASCII CR and LF characters and the block terminator as an ASCII ETX character (CRLF / ETX).

Ptr Parity causes the terminal to send the data to the SERIAL 2 (printer) port with none, odd, mark, even, or space parity.

Printer RCV ON/OFF

Wprt Reverse sets the write-protected characters to appear in reverse (dark characters on a light background).

Ptr Baud rate sets the SERIAL 2 (printer) port baud rate to 75, 150, 300, 600, 1200, 2400, 4800, 7200, 9600, 19200, 38400, 57600, 76800, 115200, 230400, 460800.

Ptr Rcv Hndshake sets the printer receive handshake through SERIAL 2 to be none, DTR, Xon / Xoff, DTR/Xoff .

Wprt Underline sets the write-protected characters to appear underlined.

Ptr Data/Stop Bits sets the data and stop bits through the SERIAL 2 (printer) port.

Ptr Xmt Hndshake sets the printer handshake to be none, DSR, Xon / Xoff, or Both .

F6-Tabs SET-UP Menu

On the tabs setup menu screen, the terminal's current tab stops are indicated by uppercase T's displayed along a line of periods that mark each column position.

(1) A tab stop in columns 2 through 78 is shown as a T in the upper line of periods

(2) A tab stop in columns 79 through 132 is shown as a T in the lower line of periods

The user can easily determine where tabs are set by moving the cursor across the line and reading the column number displayed on the right side of the screen. Clear and set tabs anywhere on the line, as follows:

(1) To move the cursor across the line, press <→> (right arrow) or <←> (left arrow)

(2) To either clear or set (toggle) an individual tab stop at the cursor position, press <Spacebar>

(3) To clear all tabs, press <Home>

(4) To set tabs to the default setting (every eighth column), press <Backspace>

Note: A tab stop cannot be set to column 1.

F7- FKeys SET-UP Definition Setup Menu

The function keys and many of the editing keys can be redefined to send a unique character string of up to 64 characters. Keys that are not programmed will send a default sequence, which is determined by the personality selected. Table 4 lists the programmable keys.

To redefine a key:

1. Select the key to be redefined by pressing that key together with <Ctrl>. This highlights the key's definition field.
2. Press <↑> (up arrow) to select the shifted or unshifted key definition field.
3. Enter the key definition (up to 62 characters) at the cursor position. Correct errors by pressing <←> (left arrow) to delete characters or <Home> to clear the definition.
4. If the user wants to change the key's direction, press <Enter> (on the numeric pad) until the desired choice appears. Direction determines where the key data is transmitted:
 - Remote: Sends data to the CPU only, regardless of the terminal's communication mode. (Until redefined, the direction of all the programmable keys is remote.)
 - Local: Sends data to the terminal only, regardless of the terminal's communication mode
 - Normal: Sends data to the CPU and / or the terminal, depending on the terminal's communication mode

Table 4- Programmable Keys

Enhanced PC-Style Keyboard	Enhanced PC-Style Keyboard
F1 through F12	ENTER (Both ENTER keys are programmable)
↑ (UP ARROW)	ESCAPE
↓ (DOWN ARROW)	HOME
← (LEFT ARROW)	INSERT
→ (RIGHT ARROW)	PAGE DOWN
BACKSPACE	PAGE UP
DELETE	PRINT SCREEN
END	TAB

F8- Ansbk SET-UP Menu

A message of up to 20 characters can be programmed to identify the terminal to the CPU. Enter the message at the cursor position. Correct errors by pressing < ← > (left arrow) to delete characters or <Home> to clear the message.

CONCEAL hides the answerback message, so it is not displayed in setup mode.

To save the message in nonvolatile memory, exit Setup mode with the **YES** option.

F9- Lan Setup Menu

This menu configures the terminal for Ethernet communication. Use of Ethernet communications provides the additional ability to open multiple sessions (applications) on one or more CPUs/servers at the same time. Support of these extended features requires the server to be configured to accept telnet connections.

Note: The Ethernet option in the F4 setup menu must be set to ON for the terminal to work in an Ethernet environment.

Local IP Address is the IP address assigned to this terminal. This must be a unique IP address. An example of this address is 200.200.200.10.

Netmask is a value generated by the system based on the IP address. The system administrator would have this information. An example is 255.255.255.0

Gateway This IP address is used to communicate with other networks. If a gateway is not being used this option should be blank.

Remote IP 0...B Address are for any remote CPU, or devices, that the terminal will communicate with for a specific session. These twelve remote IP addresses should all be identical if all communications will be with only one CPU. If Multiple sessions-ON in the F4 menu has been selected, and there is more than one CPU on the system, the user must specify which CPU each session will communicate with. To communicate with a different CPU for a future session, these settings must be changed.

Note 1: The Multiple session option allows 8 separate sessions if any emulation other than ECON-80 is selected. If ECON-80 emulation is selected, the Multiple session option will then allows 12 separate sessions.

Note 2: Port 23 Is the telnet service by default.

Note 3: The terminal must be powered cycled after saving for these parameters to take effect.

Term Type allows definition of the terminal with up to 40 characters. If Term Type is empty the default type is sent to the CPU by the system.

Ethernet Node ID displays the serial number of the hardware Ethernet interface device. This is a default value of the manufacturer of the hardware device and should not be changed.

F10- Colr1 Set-up Menu

Selects the color palette to be used for each screen attribute. A text sample of the selected colored is displayed next to each selection. Attribute selections are listed below.

Normal	Undl.
Dim	Undl. Blank
Blank	Undl. Blink
Blink	Undl. Blink Blank
Blink Blank	Undl. Rev
Rev	Undl. Rev Blank
Rev Blank	Undl. Rev Blink
Rev Blink	Undl. Rev Blink Blank
Rev Blink Blank	

F11- Colr2 Set-up Menu

The color functionality differs with emulation. In general VT100, VT220 and ANSI Console work with applications, which control the color directly. The remaining personalities associate colors based on existing monochrome video attributes. This section will define parameter selection based on personality selected.

Background = Will determine the color of the background screen under some conditions (16 colors).

Normal F.G. \ Normal B.G. = These fields allow the user to select the character and background color (16 colors) for data entered on the display before the application defines the color display remotely.

Border Color = The color of the border around the edge of the screen.

Cursor = Will select the color of the cursor (16 colors).

Intensity F.G. \ Intensity B.G. = These fields allow the user to select the character and background color (16 colors) for data entered on the display as Dim in ASCII emulation's and Bold in VT\ANSI emulation's before the application defines the color display remotely.

Attribute = Bold/Blink

Color mode = Is automatically selected based on the emulation selected.

Color map = Applies in WY325 mode only and determines if the monochrome attribute Reverse or Blank will be used to map monochrome attributes to color.

Color Association = OFF/ON

Table 5- Color Setup Menu

Option	ASCII (NOT WY325)	WY325 *	VTXXX	ANSI CONSOLE
Background =	The whole data area of the screen will be displayed in this color, when the application hasn't entered character or spaces with the Normal or Intensity B.G. color. Changes in Background color will affect Normal and Intensity B.G. Any clear screen commands will clear to this color.	No Function	Same as ASCII	Same as ASCII
Cursor =	Selects Cursor color	Selects Cursor color	Selects Cursor color	Selects Cursor color
Normal F.G. =	Selects color of Normal F.G.	No Function	Initial color selection at power up	Initial color selection at power up
Normal B.G. =	Selects color of Normal B.G.	No Function	Initial color selection at power up	Initial color selection at power up
Intensity F.G. =	Selects color of Intensity F.G.	No Function	Initial color selection at power up	Initial color selection at power up
Intensity B.G. =	Selects color of Intensity B.G.	No Function	Initial color selection at power up	Initial color selection at power up
Color Mode = Normal/Palette	Automatic	Automatic	Automatic	Automatic
Color Map =	No Function	See Above	No Function	No Function

* When the WY 325 personality is selected holding the Ctrl key down and depressing either the 0, 1, ..., 9 or (.) period keys in the numeric pad change the assignment of color on the screen. Each selection is called a palette and is described in Table 6.

Table 6- Color Palettes

Palette	Display Attribute	Foreground Color	Background Color
0	Normal	Green	Black
	Reverse (or blank)*1	Black	Yellow
	Intensity*2	Blue	Black
	Intensity*2 and reverse (or blank)*1	Black	Blue
	Underline	Cyan	Black
	Underline and reverse(or blank)*1	Black	Cyan
	Underline and intensity*2,*3	Red	Black
	Underline, intensity, *2 and reverse (or blank)*1	Black	Red
1	Normal	Green	Black
	Reverse (or blank)*1	Black	Red
	Intensity*2	Yellow	Black
	Intensity*2 and reverse (or blank)*1	Black	Yellow
	Underline	Cyan	Black
	Underline and reverse (or blank)*1	Black	Cyan
	Underline and intensity*2,*3	White	Black
	Underline, intensity, *2 and reverse (or blank)*1	Black	White
2	Normal	Cyan	Black
	Reverse (or blank)*1	Black	White
	Intensity*2	Red	Black
	Intensity*2 and reverse (or blank)*1	Black	Red
	Underline	Magenta	Black
	Underline and reverse (or blank)*1	Black	Magenta
	Underline and intensity*2,*3	Blue	Black
	Underline, intensity, *2 and reverse (or blank)*1	Black	Blue
3	Normal	Cyan	Black
	Reverse (or blank)*1	Black	Blue
	Intensity*2	White	Black
	Intensity*2 and reverse (or blank)*1	Black	White
	Underline	Magenta	Black
	Underline and reverse (or blank)*1	Black	Magenta
	Underline and intensity*2,*3	Yellow	Black
	Underline, intensity, *2 and reverse (or blank)*1	Black	Yellow
4	Normal	Magenta	Black
	Reverse (or blank)*1	Black	Cyan
	Intensity*2	Blue	Black
	Intensity*2 and reverse (or blank)*1	Black	Blue
	Underline	Green	Black
	Underline and reverse (or blank)*1	Black	Green
	Underline and intensity*2,*3	Red	Black
	Underline, intensity, *2 and reverse (or blank)*1	Black	Red
5	Normal	Magenta	Yellow
	Reverse (or blank)*1	Black	Black
	Intensity*2	White	White
	Intensity*2 and reverse (or blank)*1	Black	Black
	Underline	Green	Green
	Underline and reverse (or blank)*1	Black	Black
	Underline and intensity*2,*3	Cyan	Black
	Underline, intensity, *2 and reverse (or blank)*1	Black	Cyan

Table 6- Color Palettes (Cont'd)

Palette	Display Attribute	Foreground Color	Background Color
6	Normal	Yellow	Black
	Reverse (or blank)* ₁	Black	Yellow
	Intensity* ₂	Red	Black
	Intensity* ₂ and reverse (or blank)* ₁	Black	Red
	Underline	Cyan	Black
	Underline and reverse (or blank)* ₁	Black	Cyan
	Underline and intensity* ₂ ,* ₃	Magenta	Black
	Underline, intensity, * ₂ and reverse (or blank)* ₁	Black	Magenta
7	Normal	Red	Black
	Reverse (or blank)* ₁	Yellow	Red
	Intensity* ₂	Magenta	Black
	Intensity* ₂ and reverse (or blank) * ₁	Black	Magenta
	Underline	Cyan	Black
	Underline and reverse (or blank)* ₁	Black	Cyan
	Underline and intensity* ₂ ,* ₃	Green	Black
	Underline, intensity, * ₂ and reverse (or blank) * ₁	Black	Green
8	Normal	White	Black
	Reverse (or blank)* ₁	Black	White
	Intensity* ₂	Red	Black
	Intensity* ₂ and reverse (or blank)* ₁	Black	Red
	Underline	Yellow	Black
	Underline and reverse (or blank)* ₁	Black	Yellow
	Underline and intensity* ₂ ,* ₃	Magenta	Black
	Underline, intensity, * ₂ and reverse (or blank)* ₁	Black	Magenta
9	Normal	White	Black
	Reverse (or blank)* ₁	Black	White
	Intensity* ₂	Yellow	Black
	Intensity* ₂ and reverse (or blank)* ₁	Black	Yellow
	Underline	Blue	Black
	Underline and reverse (or blank)* ₁	Black	Blue
	Underline and intensity* ₂ ,* ₃	Cyan	Black
	Underline, intensity, * ₂ and reverse (or blank)* ₁	Black	Cyan
10 (Soft Palette)	Normal	Green	Black
	(soft Reverse (or blank)* ₁ palette) Intensity* ₂	Black	Yellow
	Intensity* ₂ and reverse (or blank)* ₁	Blue	Black
	Underline	Black	Blue
	Underline	Cyan	Black
	Underline and reverse (or blank)* ₁	Black	Cyan
	Underline and intensity* ₂ ,* ₃	Red	Black
	Underline, intensity, * ₂ and reverse (or blank)* ₁	Black	Red

*1. Whether the reverse or blank attribute is mapped to the colors shown depends on an escape sequence or the setting of the Color Map setup parameter on the Attribute menu. The default is *reverse*. When the *blank* attribute is mapped, only the background is visible.

*2. The intensity is *dim* in ASCII personalities and *bold* in ANSI personalities. (The intensity attribute is not supported in the following personalities: Wyse 50+, ADDS A2, TVI 910+, TVI925, and VT52.) The attribute can be disabled by an escape sequence or in setup mode (Intensity Attribute parameter).

*3. In each palette, the status line displays the same foreground and background colors as shown here for the underline-and-intensity attribute.

4.3 Local Keyboard Commands

Table 7 lists local keyboard commands in the terminal's native mode.

Table 7- Local Keyboard Commands in Native Mode

Key Sequence by keyboard Style

Command	Enhanced PC
Toggle CAPS LOCK on/off	CAPS LOCK
Toggle NUM LOCK on/off	NUM LOCK
Put terminal in SETUP mode	ALT ESC
Partially reset terminal, including communication unlock keyboard, turn off all print modes	ALT PAUSE
Send break* ₁	BREAK* ₂
Toggle between block and full-duplex modes	SHIFT BREAK
Print Screen formatted	PRINT SCREEN
Turn auxiliary print mode on/off	SHIFT SYS REQ* ₃
Turn monitor mode on/off	CTRL SHIFT 1 (kpd)
Turn status line display on/off	CTRL
Speed scrolling rate	CTRL SHIFT
Slow scrolling rate	CTRL SHIFT
Home cursor and clear page	CTRL SHIFT HOME
Display page 0	CTRL 0kpd
Display page 1	CTRL 1kpd
Display next page (or active other window) * ₄	PAGE DOWN
Display previous page (or active other window) * ₅	PAGE UP
Toggle between split screen* ₅ and full screen format	CTRL SHIFT –kpd
Toggle Session 0* ₆	ALT F1
Toggle Session 1* ₆	ALT F2
Toggle Session 2* ₆	ALT F3
Toggle Session 3* ₆	ALT F4
Toggle Session 4* ₆	ALT F5
Toggle Session 5* ₆	ALT F6
Toggle Session 6* ₆	ALT F7
Toggle Session 7* ₆	ALT F8
Toggle Session 8* ₆	ALT F9
Toggle Session 9* ₆	ALT F10
Toggle Session A* ₆	ALT F11
Toggle Session B* ₆	ALT F12
Close the active Session by Local Terminal* ₆	CTRL SHIFT. Kpd

*1. To MODEM port only when configured as data port: has no effect on AUX port.

*2. [BREAK] = [PAUSE] pressed together with [CTRL].

*3. [SYS REQ] = [PRINT SCREEN] pressed together with [CTRL].

*4. If screen is split.

*5. Splits screen at line 12.

*6. Only active at Ethernet mode ON.

4.4 TERMINAL Command Guide

4.4.1 Commands Supported in ASCII Personalities

Table 8 lists all the ASCII commands recognized by the terminal. The native mode code for the command is given in the second column. (The native mode includes WY-325,WY-120 and WY-60.) The remaining columns show the support for the command in other ASCII personalities according to the following notations:

Same

Same as native code (code is native to other terminal also)

Wyse

Same as native code (Wyse enhancement- code not native to other terminal)

ENH

Same as native code when enhance mode is ON (Wyse enhancement - code not native to other terminal) A code listed under a nonnative personality indicates that the related terminal's native code is supported.

A blank in any column indicates that the command is not supported.

Variables are shown in italics. Their values are listed in alphabetical order at the end of the table. Footnotes are found at the end of Table 8 on page 46.

Table 8- Commands Supported in ASCII Personalities

FUNCTION	Command				
	Native Mode	Wyse WY-50+	ADDS VP A2	TVI 910+/925	PC Term
Monitor Mode					
Monitor mode on	ESC U	Same		Same	Same
Monitor mode off	ESC u or ESC X	Same		Same	Same
Selecting Personalities					
Enhance mode off	ESC ~ SPACE	Same	ENH	ENH	ESC v SPACE
Enhance mode on	ESC ~ !	Same	ENH	ENH	ESC v !
Select WY-50+ mode	ESC ~ "	Same	ENH	Wyse	ESC v "
Select TVI 910+ mode	ESC ~ #	Same	ENH	Wyse	ESC v #
Select TVI 925 mode	ESC ~ \$	Same	ENH	Wyse	ESC v \$
Select ADDS VP A2 mode	ESC ~ %	Same	ENH	Wyse	ESC v %
Select Console ANSI mode	ESC ~ A	Same	ENH	Wyse	ESC v A
Select Native mode	ESC ~ 4	Same	ENH	Wyse	ESC v 4
Select PC Term mode	ESC ~ 5	Same	ENH	Wyse	ESC v 5
Select VT52 mode	ESC ~ 6	Same	ENH	Wyse	ESC v 6
Select VT100 mode	ESC ~ ;	Same	ENH	Wyse	ESC v ;
Select PCGRAPHIC mode* ₁	ESC ~ I	Same	ENH	Wyse	ESC v I
Select VT220-7 mode	ESC ~ <	Same	ENH	Wyse	ESC v <
Select VT220-8 mode	ESC ~ =	Same	ENH	Wyse	ESC v =
Select WY-325 mode* ₃	ESC ~ B	Same	ENH	Wyse	ESC v B
Communicating with the computer					
Enable transmission	CTRL Q	Same	Same	Same	Same
Stop transmission Disconnect	CTRL S	Same	Same	Same	Same
Send ACK (if ACK mode on)	CTRL E	Same		Wyse	Same

Table 8- Commands Supported in ASCII Personalities (Cont'd)

FUNCTION	Command				
	Native Mode	Wyse WY-50+	ADDS VP A2	TVI 910+/925	PC Term
ACK mode off	ESC e 6	Same		ENH	
ACK mode on	ESC e 7	Same		ENH	
Full-duplex mode on	ESC C ESC D F	Same		Same	ESC }
Half-duplex mode on	ESC C ESC D H	Same		Same	ESC {
Block mode on	ESC B	Same		Same	Same
Block mode off (conversation)					ESC C
Half-duplex block mode on	ESC D H ESC B	Same		Same	ENH
Set Serial 1 port receive handshaking protocol	ESC c 2 <i>hndshk</i>	Same	ENH		
Set Serial 1 port transmit handshaking protocol	ESC c 4 <i>hndshk</i>	Same	ENH		
Set maximum data transmission speed for host port	ESC c 6 <i>max</i>				
Set Serial 1 port operating parameters	ESC c 0 <i>baud stop parity word</i>				
Set Serial 2 port operating parameters	ESC c 1 <i>baud stop parity word</i>				
Enable DTR Serial port 1 Handshaking			CTRL N	CTRL N	CTRL N
Enable X-on/X-off Serial port 1			CTRL O	CTRL O	CTRL O
Program answerback message	ESC c; <i>answer</i> CTRL Y	Same	ENH		
Conceal answerback message	ESC c =	Same	ENH		
Send answerback message	ESC c <	Same	ENH		
Turn answerback mode off	ESC e SP	Same	ENH		
Turn answerback mode on	ESC e !	Same	ENH		
Controlling the Terminal and Keyboard					
Sound bell	CTRL G	Same	Same	Same	Same
Select <i>bell volume</i>	ESC c \ <i>volume</i>	Same	ENH		
Unlock keyboard	CTRL N or ESC"	Same	CTRL B	ESC "	ESC "
Lock keyboard	CTRL O or ESC#	Same	CTRL D	Same	ESC #
CAPS LOCK off	ESC e '	ENH	ENH	ENH	ESC SP M
CAPS LOCK on	ESC e &	ENH	ENH	ENH	ESC SP L
NUM LOCK off	ESC e @	ENH	ENH	ENH	ESC SP K
NUM LOCK on	ESC e A	ENH	ENH	ENH	ESC SP J
SCROLL LOCK off	ESC e B	ENH	ENH	ENH	ESC SP O
SCROLL LOCK on	ESC e C	ENH	ENH	ENH	ESC SP N
Keyclick off	ESC e \$	Same	ENH	ESC <	ESC <
Keyclick on	ESC e %	Same	ENH	ESC >	ESC >
Margin bell off	ESC e L	Same	ENH	ENH	ESC n
Margin bell on	ESC e M	Same	ENH	ENH	ESC o
Set margin bell at curs position	ESC ' J	Same	ENH		
Select standard ASCII key code mode	ESC e H	Same	ENH		
Select PC scan code mode	ESC e I	Same	ENH		
Key repeat off	ESC e ,	Same	ENH	ENH	
Key repeat on	ESC e -	Same	ENH	ENH	
Read keyboard status					ESC [
Redefining the keys					
Clear function key definition	ESC z <i>fkey</i> DEL	Same			
Clear key direction and definition	ESC Z <i>dir key/fkey</i> DEL	Same	ENH		

Table 8- Commands Supported in ASCII Personalities (Cont'd)

FUNCTION	Command				
	Native Mode	Wyse WY-50+	ADDS VP A2	TVI 910+/925	PC Term
Program function key definition	ESC z <i>fkey sequence</i> DEL	Same	ENH	ENH	
Program key direction and definition	ESC Z <i>dir key/fkey sequence</i> DEL	Same		Wyse	ESC <i>p1 p2 sequence</i> CTRL Y
Read key direction and definition	ESC Z <i>~key</i> or ESC Z <i>~fkey</i>	Same			
Screen and Cursor Display					
Screen display off	ESC ` 8	Same	ENH	ESC o	ESC O
Screen display on	ESC ` 9	Same	ENH	ESC n	ESC N
Screen saver off	ESC e P	Same	ENH	ENH	
Screen saver on	ESC e Q	Same	ENH	ENH	
Set reverse screen	ESC ^ 1	Same	ENH	ESC b	
Restore normal screen	ESC ^ 0	Same	ENH	ESC d*4	
Set scrolling speed and type	ESC ` <i>scroll</i>	Same	ENH		
Smooth scrolling on				ESC 8*5	
Smooth scrolling off				ESC 9*5	
Set cursor display features	ESC ` <i>cursor</i>	Same	ENH	ESC . <i>cursor1</i>	ESC . <i>cursor1</i>
Cursor display off	ESC ` 0	Same	CTRL W		
Cursor display on	ESC ` 1	Same	CTRL X		
25th line display off				ESC e	
Displaying the Message Fields					
Extended status line on	ESC ` a	Same	ENH		
Standard status line on	ESC ` b	Same	ENH		
Status line off	ESC ` c	Same	ENH		
Program/display CPU message on status line	ESC F <i>message</i> CR	Same	ENH		
Program CPU message on unshifted label line*6	ESC z (<i>text</i> CR	Same	ENH	ESC f*5 <i>text</i> CR	ESC f <i>text</i> CR
Program CPU message on shifted label line	ESC z) <i>text</i> CR	Same	ENH		
Turn off shifted label line	ESC z DEL	Same	ENH	ENH	
Clear unshifted label line	ESC z (CR	Same	ENH		
Clear shifted label line	ESC z) CR	Same	ENH	ENH	
Program/display function key label	ESC z <i>field label</i> CR	Same	ENH	ENH	
Clear function key label	ESC z <i>field</i> CR	Same	ENH	ENH	
Defining the data Area					
Select 80-column display	ESC ` :	Same	ENH		
Select 132-column display	ESC ` ;	Same	ENH		
Economy 80-column mode off	ESC e F	Same	ENH		
Economy 80-column mode on	ESC e G	Same	ENH		
Width-change-clear mode off	ESC e .	Same	ENH		
Width-change-clear mode on	ESC e /	Same	ENH		
Display 24 data lines*7	ESC e (Same	ENH		
Display 25 data lines*7	ESC e)	Same	ENH		ESC ^

Table 8- Commands Supported in ASCII Personalities (Cont'd)

FUNCTION	Command				
	Native Mode	Wyse WY-50+	ADDS VP A2	TVI 910+/925	PC Term
Display Memory/Split Screen					
Divide memory into pages	ESC w <i>length</i>	Same	ENH		
Display previous page	ESC w B or ESC J*8	Same	ENH	ESC J	
Display next page	ESC w C or ESC K*8	Same	ENH	ESC K	
Display page n	ESC w <i>page</i>	Same	ENH		
Split screen horizontally (simple split)	ESC x A <i>line</i>	Same			
Split screen horizontally (simple split) and clear pages	ESC x 1 <i>line</i>	Same			
Split screen horizontally (adjustable split) and clear pages	ESC x 3 <i>line</i>	Same			
Split screen horizontally (adjustable split)	ESC x C <i>line</i>	Same			
Activate upper window	ESC]	Same			
Activate lower window	ESC }	Same			
Activates other window (or page *8)	ESC J or ESC K	Same	ESC J+5		
Lower horizontal split	ESC x P	Same			
Raise horizontal split	ESC x R	Same			
Roll window up in page	ESC w E	Same			
Roll window down in page	ESC w F	Same			
Redefine screen as one window	ESC x @	Same			
Redefine screen as one window and clear pages	ESC x 0	Same			
Display Attributes					
Assign display attribute to a message field	ESC A <i>mf attr</i>	Same	ESC \+4		
Assign character display attribute	ESC G <i>attr</i>	Same	ENH	Same	Same
Character attribute mode off	ESC e 0				
Character attribute mode on	ESC e 1				
Page attribute mode on	ESC e 2	Same			
Line attribute mode on	ESC e 3	Same			
Assign write-protected character display attribute	ESC ` <i>wpc</i>	Same	ESC 0 <i>wpc</i>		
Clear unprotected page to display attribute	ESC !	ENH <i>attr</i>	Wyse		
Assign line attribute	ESC G <i>latr</i>	Same	ENH		
Redefine color map values*9	ESC d y <i>fcolor</i> <i>bcolor map</i>				
Set tag protect attribute			CTRL N		
Reset tag protect attribute			CTRL O		
Select a predefined color palette*9	ESC d z <i>palette</i>				
Map blank attribute*9	ESC d {				
Map reverse attribute*9	ESC d				
Protecting Data					
Write-protect mode off	ESC (Same	CTRL O	Same	Same
Write-protect mode on	ESC)	Same	CTRL N	Same	Same
Clear cursor column to write-protected spaces	ESC V	Same	ENH	Same	
Protect mode off	ESC ,	Same	ENH	Same	Same
Protect mode on	ESC &	Same	ENH	Wyse	Same

Table 8- Commands Supported in ASCII Personalities (Cont'd)

FUNCTION	Command				
	Native Mode	Wyse WY-50+	ADDS VP A2	TVI 910+/925	PC Term
Graphics Characters					
Graphics mode on	ESC H	CTRL B	Same	ESC \$	ESC \$
Graphics mode off	ESC H	CTRL C	Same	ESC %	ESC %
Display graphics character	ESC H <i>ldraw</i>	Same			
Controlling the Cursor					
Cursor left (backspace)	CTRL H	Same	Same	Same or CTRL U	Same
Cursor right	CTRL L	Same	CTRL F	Same	Same
Cursor up; no scroll	CTRL K	Same	CTRL Z	Same	Same
Cursor up; scroll (reverse linefeed)	ESC j	Same	ENH	Same*10	Same
Cursor down; no scroll				CTRL V	CTRL V
Cursor down; scroll (Linefeed)	CTRL J	Same	Same	Same	Same
Cursor to start of line	CTRL M		Same	Same	Same
Cursor to start of next line	CTRL _	Same	ENH	Same	Same
Home cursor	ESC { or CTRL ^	Same	ENH or CTRL A	Wyse Same	CTRL ^
Cursor to specific column			CTRL P <i>col</i>	ESC] *11	
Cursor to specific line			CTRL K <i>line</i>	ESC [
End-of-line wrap off	ESC d .	Same	ENH		ESC 0
End-of line wrap on	ESC d /	Same	ENH		ESC ~
Received CR mode off	ESC e 4	Same	ENH	ENH	ESC 9
Received CR mode on	ESC e 5	Same	ENH	ENH	ESC 8
Autopage mode off	ESC d *	Same	ENH	ESC w	
Autopage mode on	ESC d +	Same	ENH	ESC v	
Autoscrolling mode off	ESC N	Same	ENH		
Autoscrolling mode on	ESC O	Same	ENH		
Address cursor in current 80-column page	ESC = <i>line col</i>	Same	ENH or ESC Y	Same	Same
Address cursor in specific 80-column page	ESC w @ <i>page line col</i>	Same	ENH	ESC - <i>page line col</i>	
Address cursor in specific 80-column window/page*8	ESC - <i>wnd/ page line col</i>	Same	ENH		Same
Address cursor in specific 80/132-column current page	ESC a <i>lll R</i>	Same	ENH		Same
Read cursor line and column address in 80-column current page	<i>ccc C</i>	Same	ENH	Same	Same
Read 80-column page number and cursor address	ESC ?	Same	ENH	Same	Same
Read 80-column window/page number and cursor address	ESC w □	Same	ENH		
Read cursor address in 80/132-column page	ESC /	Same	ENH	Same	Same
Editing					
Clear all tab stops	ESC 0	Same	ENH	ESC 3	ESC 3
Set tab stop	ESC 1	Same	ENH	Same	Same
Clear tab stop	ESC 2	Same	ENH	Same	Same
Tabulate cursor	ESC i or CTRL I	Same	ENH	CTRL I	CTRL I
Backtab	ESC I	Same	ENH	Same	Same
Field tab				ESC I	ESC i
Insert mode on, replace mode off	ESC q	Same	ENH	ENH	ESC Z
Insert mode off, replace mode on	ESC r	Same	ENH	ENH	Same
Insert space character	ESC Q	Same	ENH	Same	Same

Table 8- Commands Supported in ASCII Personalities (Cont'd)

FUNCTION	Command				
	Native Mode	Wyse WY-50+	ADDS VP A2	TVI 910+/925	PC Term
Editing (Cont'd)					
Insert line of spaces	ESC E	Same	ENH	Same	Same
Delete cursor character	ESC W	Same	ENH	Same	Same
Delete cursor line	ESC R	Same	ESC I	Same	Same
Clearing Data					
Clear page to nulls	ESC *	Same	ENH	Same	Same
Clear page to spaces	ESC +	Same	ENH		
Clear page to write-protected spaces	ESC ,	Same	ENH		Same
Clear unprotected page to spaces	ESC ; or CTRL Z	Same	ESC ; ENH	ESC ; or ESC +	Same
Clear unprotected page to nulls	ESC :	Same	ENH	Same	Same
Clear unprotected page to a specific character	ESC . <i>char</i>	Same	ENH		
Clear unprotected page to protected spaces				ESC ,	
Clear unprotected page to display attribute		ESC ! <i>attr</i>	ENH	ENH	
Clear unprotected page to spaces from cursor	ESC Y	Same	ESC k	Same	Same
Clear unprotected page to nulls from cursor	ESC y	Same	ENH	Same	Same
Clear unprotected line to spaces from cursor	ESC T	Same	ESC K	Same	Same
Clear unprotected line to nulls from cursor	ESC t	Same	ENH	Same	Same
Fill page with H's					ESC F
Sending data					
Begin print / send at top of page	ESC d'	Same	ENH		
Begin print / send at top of screen	ESC d&	Same	ENH		
Send cursor character	ESC M	Same			
Send line through cursor	ESC 6	Same	Same	ESC 6	
Send unprotected line through cursor	ESC 4	Same	Same	ESC 4	
Send page through cursor	ESC 7	Same	ENH	Same	ESC 7
Send unprotected page through cursor	ESC 5	Same	Same	ESC 5	
Mark block beginning	ESC 8	Same	ENH		
Mark block end	ESC 9	Same	ENH		
Send entire block	ESC s	Same	ENH	Same	Same
Send unprotected	ESC S	Same	ENH	Same	Same
Report terminal status					ESC [
Report attribute under cursor					ESC D

Table 8- Commands Supported in ASCII Personalities (Cont'd)

FUNCTION	Command				
	Native Mode	Wyse WY-50+	ADDS VP A2	TVI 910+/925	PC Term
Print Functions					
Print formatted page	ESC P	Same	ENH	Same	Same
Print formatted unprotected page	ESC @	Same	ENH		
Print unformatted page	ESC p or ESC L	Same	ESC p	ESC L*11	
Select Parallel printer	ESC d (Same	Same		
Select Serial printer	ESC d)	Same	Same		
Auxiliary print mode off	CTRL T	Same	Same	ESC A	ESC A
Auxiliary print mode on	CTRL R	Same	Same	ESC @	
Transparent print mode off	CTRL T	Same	ESC 4	ESC a	ESC a
Transparent print mode on	ESC d #	Same	ESC 3	ESC `	ESC `
Bi-directional mode off	ESC d \$			CTRL T	CTRL T
Bi-directional mode on	ESC d %			CTRL	CTRL R
Auxiliary receive mode off	ESC d SPACE				
Auxiliary receive mode on	ESC d !				
Set print terminator				ESC p	ESC p
Define delimiters				ESC x	ESC x
Character Sets					
Select primary character set	ESC c D	Same			
Select secondary character set	ESC c E	Same			
Define primary character set	ESC c B <i>bank</i>	Same			
Define secondary character set	ESC c C <i>bank</i>	Same			
Load font bank with predefined	ESC c @ <i>bank set</i>	Same			
Clear font bank	ESC c ? <i>bank</i>	Same			
Define and load character	ESC c A <i>bank pp bb...bb</i> CTRL Y	Same			

*1. PCG ALPHA in Mono. Text Model machine.

*3. Valid only in Color Model machine.

*4. With enhance mode off.

*5. With enhance mode on.

*6. Automatically display in native mode. May be hidden by assigning blank attribute (ESC A I I).

*7. Screen cleared.

*8. If screen is not split.

*9. In WY-325 only

*10. In TeleVideo 925 only

*11. In TeleVideo 910+ only

5.4.2 Variable Values for Table 8 Commands

answer Up to 20 characters to define answerback message

attr	Display Attributes	attr	Display Attributes
SPACE	Space character	p	Dim
0	Normal	q	Dim and invisible
1	Blank	r	Dim and blink
2	Blink	s	Dim, blink, invisible
3	Blink and Blank	t	Dim and reverse
4	Reverse	u	Dim, reverse, invisible
5	Reverse and invisible	v	Dim, reverse, blink
6	Reverse and blink	w	Dim, reverse, blink invisible
7	Reverse, blink, invisible	x	Dim and underline
8	Underline	y	Dim, underline, invisible
9	Underline and invisible	z	Dim, underline, blink
:	Underline and blink	{	Dim, underline, blink invisible
;	Underline, blink, invisible		Dim, underline, reverse
<	Underline and reverse	}	Dim, underline, reverse invisible
=	Underline, reverse, invisible	~	Dim, underline, reverse blink
>	Underline, reverse, blink	DEL	Dim, underline, reverse blink, invisible
?	Underline, reverse, blink invisible		

bank	Font Bank^a	bank	Font Bank^a
0	Font bank 0	2	Font bank 2
1	Font bank 1	3	Font bank 3

^a Holds predefined character set

baud	Baud Rate	baud	Baud Rate	baud	Baud Rate	baud	Baud Rate
0	115200	4	19200	8	2400	<	200
1	76800	5	9600	9	1200	=	134.5
2	57600	6	7200	:	600	>	110
3	38400	7	4800	;	300	?	50

bb...bb 32-byte character string defining bit pattern of character

bcolor	Background Color	bcolor	Background Color
1	Black	5	Red
2	Blue	6	Magenta
3	Green	7	Yellow
4	Cyan	8	White

ccc One-to three-decimal value of column relative to home

char Character that replaces unprotected characters

col See line/col

color	color	color	color	color	color
1	Black	6	Magenta	D	Dim cyan
2	Blue	7	Yellow	E	Dim red
3	Green	8	White	F	Dim magenta
4	Cyan	B	Dim blue	G	Dim yellow
5	Red	C	Dim green	H	Dim white

cursor	Cursor Display	cursor	Cursor Display
0	Cursor display off	3	Blinking line cursor
1	Cursor display on	4	Steady line cursor
2	Steady block cursor	5	Blinking block cursor

dir	Direction
0	Normal
1	Remote
2	Local

Variable Values for Table 8 Commands (Cont'd)

<i>fcolor</i>	Foreground Color	<i>fcolor</i>	Foreground Color
1	Black	5	Red
2	Blue	6	Magenta
3	Green	7	Yellow
4	Cyan	8	White

<i>Key</i>	<i>field</i> Unshifted	<i>field</i> shifted	<i>Key</i>	<i>field</i> Unshifted	<i>field</i> shifted
F1	0	P	F7	6	V
F2	1	Q	F8	7	W
F3	2	R	F9	8	X
F4	3	S	F10	9	Y
F5	4	T	F11	:	Z
F6	5	U	F12	;	[

Function	<i>fkey</i>	<i>fkey</i>	Function	<i>fkey</i>	<i>fkey</i>
Key	Unshifted	Shifted	Key	Unshifted	Shifted
F1	@	`	F7	F	f
F2	A	a	F8	G	g
F3	B	b	F9	H	h
F4	C	c	F10	I	i
F5	D	d	F11	J	j
F6	E	e	F12	K	k

<i>hndshk</i>	Handshaking Protocol Receive	Transmit
0	None (default)	None (default)
1	XON/XOFF	XON/XOFF
2	DTR	
3	Both	

Keyboard Style

<i>key</i>	Enhanced PC	<i>key</i>	Enhanced PC	<i>key</i>	Enhanced PC
SPACE	ESC	&	SHIFT TAB →	\$	RETURN
%	SHIFT ESC	"	← BACKSPACE)	SHIFT RETURN
!	TAB →	'	SHIFT← BACKSPACE	*	HOME
/	SHIFT HOME	3	SHIFT →	6	SHIFT DELETE
+	↑	s	ENTER kpd	R	PRINT SCREEN
0	SHIFT ↑	4	SHIFT ENTER kpd	X	SHIFT PRINT SCREEN
,	↓	q	INSERT	\	END
1	SHIFT ↓	p	SHIFT INSERT]	SHIFT END
-	←	r	PAGE DOWN	:	PAGE UP
2	SHIFT ←	w	SHIFT PAGE DOWN	;	SHIFT PAGE UP
.	→	5	DELETE		

label 9 characters (80 columns); 7 characters (132 columns)

lattr **Line Attribute**

@	Single-high, single-wide characters
A	Single-high, double-wide characters.
B	Top half of double-high, single-wide characters
C	Bottom half of double-high, single-wide characters
D	Top half of double-high, double-wide characters
E	Bottom half of double-high, double-wide characters

<i>ldraw</i>	Graphics Character	<i>ldraw</i>	Graphics Character	<i>ldraw</i>	Graphics Character	<i>ldraw</i>	Graphics Character
0	┌	4	┐	8	┑	=	┓
1	└	5	┘	9	┒	>	□
2	┌	6	┘	:	━	?	■
3	└	7	■	;	■		

Variable Values for Table 8 Commands (Cont'd)

length	Multiple	Length of Page
G	1xlines	Equal to the number of data lines
H	2xlines	Double the number of data lines
l*b	4xlines	Four times the number of data lines

*b Available only in WY-50+ personality.

Line/Column	line/col _c	Line/Column	line/col _c	Line/Column	line/col _c	Line/Column	line/col _c
1	Space	25	8	49	P	73	h
2	!	26	9	50	Q	74	i
3	"	27	:	51	R	75	j
4	#	28	;	52	S	76	k
5	\$	29	<	53	T	77	l
6	%	30	=	54	U	78	m
7	&	31	>	55	V	79	n
8	'	32	?	56	W	80	o
9	(33	@	57	X	81	p
10)	34	A	58	Y	82	q
11	*	35	B	59	Z	83	r
12	+	36	C	60	[84	s
13	,	37	D	61	\	85	t
14	-	38	E	62]	86	u
15	.	39	F	63	^	87	v
16	/	40	G	64	_	88	w
17	0	41	H	65	`	89	x
18	1	42	I	66	a	90	y
19	2	43	J	67	b	91	z
20	3	44	K	68	c	92	{
21	4	45	L	69	d	93	
22	5	46	M	70	e	94	}
23	6	47	N	71	f	95	~
24	7	48	O	72	g	96	DEL/RUB

*c Native codes also recognized in WY-50+, TVI 910+/925, and PC Term personalities, and in ADDS VP A2 personality absolute cursor addressing.

/// One- to three-decimal value of line relative to home

map	Definition	map	Definition
1	Normal	5	Underline
2	Reverse (or blank*d)	6	Underline and reverse (or blank*d)
3	Intensity	7	Underline and intensity
4	Intensity and reverse (or blank*d)	8	Underline, intensity, and reverse (or blank*d)

*d. Colors mapped to reverse or blank depending on the setting of the Color Map setup parameter or the equivalent escape sequences.

Max	Maximum Speed
1	60 characters per second
2	No limit (default)
3	150 characters per second

message 46 characters (80 columns); 98 characters (132 columns)

mf	Screen Area_e	mf	Screen Area_e
0	Data area	2	Terminal message field
1	Function key label line	3	Computer message field

*e In native mode, only the reverse attribute can be assigned to the data area.

Variable Values for Table 8 Commands (Cont'd)

p1	Function Key	p1	Function Key
1	F1	6	F6
2	F2	7	F7
3	F3	8	F8
4	F4	9	F9
5	F5	0	F10

p2	Direction
1	Remote
2	Local
3	Normal

page	Page	
0	page 0	In the 80 columns mode: There have 4 pages of display memory.
1	page 1	In the 132 columns mode: There have 3 pages of display memory.
2	page 2	In the Econ-80 columns mode: There have 7 pages of display memory.
3	page 3	
4	page 4	
5	page 5	
6	page 6	

palette	Color Palette	palette	Color palette	palette	Color palette
0	Palette 0	4	Palette 4	8	Palette 8
1	Palette 1	5	Palette 5	9	Palette 9
2	Palette 2	6	Palette 6	.	Palette 10
3	Palette 3	7	Palette 7		

parity	Parity Bits	parity	Parity Bits
0	None	2	Mark
1	Odd	3	Even

pp 2-byte hex value of character position*_f.

*_f In the illustrations, DEC = decimal value; HEX = hexadecimal value. Read across, then down.

Scroll	Scrolling Type	Speed(lps)
@	Jump scroll	
<	Smooth scroll	1
=	Smooth scroll	2
>	Smooth scroll	4
?	Smooth scroll	8

sequence Up to 64 bytes to be loaded in function key

set	Predefined Character Set
@	Native Mode
A	PC Multinational
B	Standard ASCII
D	PC Standard
G	Standard ANSI

stop	stopbits
0	1
1	2

text 78 characters (80 columns); 130 characters (132 columns)

volume	BELL Volume	volume	BELL Volume
#	Loud	!	Low
"	Medium	SP	Off

Variable Values for Table 8 Commands (Cont'd)

wnd/page **Window or Page**
 0 Page 0 or upper window
 1 Page 1 or lower window

word **Data Word**
 0 7 bits
 1 8 bits

wpca Write-Protected Display Attribute	wpca Write-Protected Display Attribute
6 Reverse* _g	C Invisible on
7 Dim* _g	E Underline on
A Normal* _g	F Reverse on
B Blink on	G Dim on

*_g Clears other write-protected attributes

<i>wpca1</i>	Display Attribute	<i>wpca1</i>	Write-Protected Display Attribute
@	Normal	H	Normal
A	Dim	I	Dim
B	Blink	J	Blink
C	Dim/Blink	K	Dim/Blink
D	Invisible	L	Invisible
P	Reverse (Rev)	X	Reverse (Rev)
Q	Rev/Dim	Y	Rev/Dim
R	Rev/Blink	Z	Rev/Blink
S	Rev/Dim/Blink	[Rev/Dim/Blink
T	Rev/Invisible	\	Rev/Invisible
.	Underline (UL)	h	Underline (UL)
a	UL/Dim	i	UL/Dim
b	UL/Blink	j	UL/Blink
c	UL/Dim/Blink	k	UL/Dim/Blink
p	UL/Rev	x	UL/Rev
q	UL/Rev/Dim	y	UL/Rev/Dim
r	UL/Rev/Blink	z	UL/Rev/Blink
s	UL/Rev/Dim/Blink	{	UL/Rev/Dim/Blink

4.5 ANSI Command Guide

4.5.1 VT100, VT220 and Console ANSI Command Guide

Table 9 -Supported VT100,VT220 and Console ANSI Commands

FUNCTION	Command	
	VT100, VT220	Console ANSI
Controlling Functional modes*₁		
Lock keyboard	CSI 2 h	Same
Unlock keyboard	CSI 2 l	Same
Monitor mode on * ₂	CSI 3 h	Same
Monitor mode off	CSI 3 l	Same
Insert mode on	CSI 4 h	Same
Insert mode off	CSI 4 l	Same
Local echo off	CSI 12 h	Same
Local echo on	CSI 12 l	Same
New line mode on	CSI 20 h	Same
New line mode off	CSI 20 l	Same
Cursor keys send application-dependent codes	CSI ?1 h	Same
Cursor keys send cursor movement codes	CSI ?1 l	Same
VT100 mode on	CSI ?2 h or CSI 61 "p	Same
VT52 mode on	CSI ?2 l	Same
National character set mode on	CSI ?42 h	Same
National character set mode off	CSI ?42 l	Same

Table 9- Supported VT100, VT220 and Console ANSI Commands, Cont'd

Command			
FUNCTION		VT100, VT220	Console ANSI
132-column display		CSI ?3 h	Same
80-column display		CSI ?3 l	Same
Smooth scrolling on		CSI ?4 h	Same
Jump scrolling on		CSI ?4 l	Same
Reverse screen video on		CSI ?5 h	Same
Normal screen video on		CSI ?5 l	Same
Line 1 is top of scrolling region		CSI ?6 h	Same
Line 1 is top of display area		CSI ?6 l	Same
Autowrap on		CSI ?7 h	Same
Autowrap off		CSI ?7 l	Same
Autorepeat on		CSI ?8 h	Same
Autorepeat off		CSI ?8 l	Same
Block mode on		CSI ?10 h	Same
Block mode off		CSI ?10 l	Same
Send form feed after print screen operation		CSI ?18 h	Same
No form feed sent after print screen operation		CSI ?18 l	Same
Print full screen		CSI ?19 h	Same
Print scrolling region		CSI ?19 l	Same
Display cursor		CSI ?25 h	Same
Cursor off		CSI ?25 l	Same
Blank screen		CSI 30 h	Same
Display screen		CSI 30 l	Same
Display status line		CSI 31 h	Same
Blank status line		CSI 31 l	Same
Screen saver		CSI 32 h	Same
Screen saver off		CSI 32 l	Same
Cursor steady (nonblinking)		CSI 33 h	Same
Cursor blinking		CSI 33 l	Same
Underline cursor on		CSI 34 h	Same
Block cursor on		CSI 34 l	Same
Don't clear screen after width change		CSI 35 h	Same
Clear screen after width change		CSI 35 l	Same
Send erasable and nonerasable characters		CSI 37 h	Same
Send only erasable characters		CSI 37 l	Same
Send full screen		CSI 38 h	Same
Send scrolling region		CSI 38 l	Same
Turn 25th line on		CSI 40 h	Same
Turn 25th line off		CSI 40 l	Same
Select standard ANSI key codes		CSI 54 h	Same
Select PC scan codes		CSI 54 l	Same
VT220 8-bit mode on		CSI 62;2"p	Same
VT220 7-bit mode on		CSI 62;1"p	Same
8-bit transmission mode on (VT220)		ESC space G	
7-bit transmission mode on (VT220)		ESC space F	
Select next page			CSI U
Select preceding page			CSI V
Select page 0			CSI 0 z
Select page 1			CSI 1 z
Character Set Selection		ESC Ps final	Same
Ps	Label assigned	Ps	Label assigned
(G0	*	G2(VT220 only)
)	G1	+	G3(VT220 only)

Table 9- Supported VT100, VT220 and Console ANSI Commands, Cont'd

<i>final</i>	Final character	<i>final</i>	Final character
A	Designating UK ANSI character set	<	Designating DEC supplemental(VT220 only)
B	Designating ASCII character set	DSCS*	Designating Down-line loadable character set
0	Designating DEC special graphics		

* DSCS can consist of zero, one or two intermediate character and a final character. Intermediate characters are in the range of 2/0 to 2/15. Final characters are in the range of 3/0 to 7/14

FUNCTION	Command	
	VT100, VT220	Console ANSI
Load G0 character set into GL	CTRL O	Same
Load G1 character set into GL	CTRL N	Same
Load G1 character set into GR	ESC ~	Same
Load G2 character set into GL	ESC n	Same
Load G2 character set into GR	ESC }	Same
Load G3 character set into GL	ESC o	Same
Load G3 character set into GR	ESC	Same
Shift G2 character set into GL for one character only	ESC N	Same
Shift G3 character set into GL for one character only	ESC O	Same

Controlling Character, Field, and Line Attributes

Define character attributes₃ **CSI Ps m** **Same**

<i>Ps</i>	Character Attribute	<i>Ps</i>	Character Attribute
0	Normal (all attributes off)	25	Blink off
1	Bold (blank off)	27	Reverse off
4	Underline	28	Blank off
5	Blink	30	Black character
7	Reverse	31	Red character
8	Blank (bold off)	32	Green character
22	Normal intensity	33	Brown character (Bold on = Yellow)
24	Underline off	34	Blue character

Command			
FUNCTION	VT100, VT220		Console ANSI
	<i>Ps</i>	Character Attribute	<i>Ps</i>
35	Magenta character	43	Brown background (Bold on = Yellow)
36	Cyan character	44	Blue background
37	White character	45	Magenta background
40	Black background	46	Cyan background
41	Red background	47	White background
42	Green background		

Select Graphic Rendition (Console ANSI mode only) **CSI ps m**

<i>ps</i>	Function
10	Select Primary Font
11	Select First Alternate Font. Allows ASCII characters less than 32 to be displayed as ROM character.
12	Select Second Alternate Font. Toggles high bit of extended ASCII code before displaying as ROM character.

Set bold background bit	ESC[= <i>Pn</i> E	same
Pn = 0: set bit 7 of attribute byte as B/G intensity 1: set bit 7 of attribute byte as B/G blink		
Set normal foreground color	ESC[= <i>Psn</i> F	same
Set normal background color	ESC[= <i>Psn</i> G	same
Set reverse foreground color	ESC[= <i>Psn</i> H	same
Set reverse background color	ESC[= <i>Psn</i> I	same
Set graphic foreground color	ESC[= <i>Psn</i> J	same
Set graphic background color	ESC[= <i>Psn</i> K	same
Set border color	ESC[= <i>Psn</i> A	same

Table 9- Supported VT100, VT220 and Console ANSI Commands, Cont'd

FUNCTION				Command			
				VT100, VT220		Console ANSI	
<i>Psn</i>	Color	<i>Psn</i>	Color	<i>Psn</i>	Color	<i>Psn</i>	Color
0	Black	4	Red	8	Gray	12	Lt. Red
1	Blue	5	Magenta	9	Lt. Blue	13	Lt. Magenta
2	Green	6	Brown	10	Lt. Green	14	Yellow
3	Cyan	7	White	11	Lt. Cyan	15	Lt. White
Access alternate graphic set						CSI Png	
Define erasable character				CSI 0 "q or CSI 2 "q		Same	
Define non-erasable character				CSI 1 "q		Same	
Define top half of double-high, double-wide line				ESC # 3		Same	
Define bottom half of double-high, double-wide line				ESC # 4		Same	
Define single-high, single-wide line				ESC # 5		Same	
Define single-high, double-wide line				ESC # 6		Same	
Define top half of double-high, single-wide line				ESC # :		Same	
Define bottom half of double-high, single-wide line				ESC # ;		Same	
Controlling the Cursor							
Display cursor				CSI ?25 h		Same	
Cursor off				CSI ?25 l		Same	
Cursor steady (nonblinking)				CSI 33 h		Same	
Cursor blinking				CSI 33 l		Same	
Underline cursor on				CSI 34 h		Same	
Block cursor on				CSI 34 l		Same	
Cursor keys send application-dependent codes				CSI ?1 h		Same	
Cursor keys send cursor movement codes				CSI ?1 l		Same	
Move cursor to n column				CSI n G or CSI n `		Same	
Move cursor up n lines				CSI n A		Same	
Move cursor down n lines				CSI n B or CSI n e		Same	
Move cursor right n columns				CSI n C or CSI n a		Same	
Move cursor left n columns				CSI n D		Same	
Move cursor down cursor n line to column 1				CSI n E		Same	
Move cursor up n lines to column 1				CSI n F		Same	
Move cursor to line n				CSI n d		Same	
Move cursor to line n1, column n2				CSI n1; n2 H or CSI n1; n2 f		Same	
Move cursor down one line in current column, scroll up if at bottom line				IND or ESC D		Same	
Move cursor down one line in current column, execute CR if linefeed mode is on				CTRL J or CTRL K or CTRL L		Same	
Move cursor up one line in current column, scroll down if at top line				RI or ESC M		Same	
Move cursor down one line to column 1				NEL or ESC E		Same	
Save display attributes, cursor position, character sets, wrap flag and origin mode status				ESC 7 or CSI s		Same	
Restore last saved display attributes, cursor position, character set, wrap flag, and origin mode status				ESC 8 or CSI u		Same	
Backspace cursor				CTRL H		Same	
Move cursor to next tab stop				CTRL I		Same	
Move cursor to column 1 of current line				CTRL M		Same	
Editing Functions							
Erase from cursor to end of display				CSI 0 J		Same	
Erase from start of display to cursor				CSI 1 J		Same	
Erase entire display				CSI 2 J		Same	
Erase from cursor to end of line				CSI 0 K		Same	
Erase from start of line to cursor				CSI 1 K		Same	
Erase entire line				CSI 2 K		Same	
Erase erasable characters from cursor to end of display				CSI ?0 J		Same	

Table 9- Supported VT100, VT220 and Console ANSI Commands, Cont'd

FUNCTION	Command	
	VT100, VT220	Console ANSI
Editing Functions (Cont'd)		
Erase erasable characters from start of display to cursor	CSI ?1 J	Same
Erase erasable characters in entire display	CSI ?2 J	Same
Erase erasable characters from cursor to end of line	CSI ?0 K	Same
Erase erasable characters from start of line to cursor	CSI ?1 K	Same
Erase erasable characters from entire line	CSI ?2 K	Same
Erase n characters beginning at cursor	CSI n X	Same
Insert n blank characters beginning at cursor	CSI n @	Same
Insert n blank lines beginning at cursor line	CSI n L	Same
Delete n line beginning at cursor line	CSI n M	Same
Delete n characters beginning at cursor	CSI n P	Same
Controlling Margins		
Set top/bottom margins of scrolling	CSI t;b r	Same
<p>t: Top line number b: Bottom line number (optional; if omitted, treated as bottom screen line)</p>		
Controlling Tabs		
Clear tab stop at cursor	CSI 0 g or CSI 2 W	CSI 2W
Clear all tab stops	CSI 3 g or CSI 5 W	CSI 5W
Set tab stop at cursor	CSI 0 W or ESC H	Same
Set tab stop every 8th column	CSI ?5 W	Same
Move forward n tab stops	CSI n I	Same
Move backward n tab stops	CSI n Z	Same
Move cursor to next tab stop	CTRL I	Same
Controlling Scrolling		
Smooth scrolling on	CSI ?4 h	Same
Jump scrolling on	CSI ?4 l	Same
Set 0 lps smooth scrolling speed	CSI 0 z	
Set 1 lps smooth scrolling speed	CSI 1 z	
Set 2 lps smooth scrolling speed	CSI 2 z	
Set 4 lps smooth scrolling speed	CSI 3 z	
Set 8 lps smooth scrolling speed	CSI 4 z	
Program function keys		
	DCS c;kl kc/hc ST	ESC Q Fn "string"
1. VT100 mode:		
c	Clear	kl
0	Clear all key definitions	0
1	Clear keys only as they are redefined	1
kc	Shifted function key	kc
12	F1	18
13	F2	19
14	F3	20
15	F4	21
16	F5	23
17	F6	24
		F7
		F8
		F9
		F10
		F11
		F12

Table 9- Supported VT100, VT220 and Console ANSI Commands, Cont'd

FUNCTION	Command	
	VT100, VT220	Console ANSI
Program function keys	DCS c;k kcl/hc ST	ESC Q Fn "string"
1. VT100 mode (cont'd):		
kc	Unshifted function key	kc
6	F1	38
7	F2	39
8	F3	40
9	F4	41
10	F5	43
37	F6	44
		44
		F12

hc Hexadecimal representation of character string assigned to the function key.

Note: Multiple function key definitions can be programmed by entering the <kc>/<hc> parameters for each, separated by semicolons (;).

2. Console ANSI mode:

Redefine keys with string

Function: Define Specific Programmable Function key or Numeric keypad with String.

Format: ESC Q Fn " string "

Parameters: Fn

0 - F1	< - S_F1	H - C_F1	T - C_S_F1
1 - F2	= - S_F2	I - C_F2	U - C_S_F2
2 - F3	> - S_F3	J - C_F3	V - C_S_F3
3 - F4	? - S_F4	K - C_F4	W - C_S_F4
4 - F5	@ - S_F5	L - C_F5	X - C_S_F5
5 - F6	A - S_F6	M - C_F6	Y - C_S_F6
6 - F7	B - S_F7	N - C_F7	Z - C_S_F7
7 - F8	C - S_F8	O - C_F8	[- C_S_F8
8 - F9	D - S_F9	P - C_F9	\ - C_S_F9
9 - F10	E - S_F10	Q - C_F10] - C_S_F10
: - F11	F - S_F11	R - C_F11	^ - C_S_F11
; - F12	G - S_F12	S - C_F12	_ - C_S_F12

for numeric keypad:

` - '7' key	c - '-' key	f - '6' key	i - '2' key
a - '8' key	d - '4' key	g - '+' key	j - '3' key
b - '9' key	e - '5' key	h - '1' key	k - '0' key

Notes:

- The string should not include the delimiter, or unexpected conditions maybe occur.
- The defined contents of F1 ~F12 will be transmitted out by keying F1~F12.
The defined contents of S_F1~S_F12 will be transmitted out by multi-keying the Shift and Function key.
The defined contents of C_F1~C_F12 will be transmitted out by multi-keying the Ctrl and Function key.
The defined contents of C_S_F1~C_S_F12 will be transmitted out by multi-keying the Ctrl, Shift and Function key.

Examples: Define Function Key F1 to the character ABC123: ESC Q 0"ABC123"

FUNCTION	Command	
	VT100, VT220	Console ANSI
Auxiliary Keypad Modes		
Auxiliary keypad numeric mode on	ESC >	Same
Auxiliary keypad application mode on	ESC =	Same

Table 9- Supported VT100, VT220 and Console ANSI Commands, Cont'd

FUNCTION	Command	
	VT100, VT220	Console ANSI
Transmission/Printer Control		
Transmit through cursor position	CSI 16 h	Same
Transmit to end of line or end of display	CSI 16 l	Same
Send form feed after print screen operation	CSI ?18 h	Same
No form feed sent after print screen operation	CSI ?18 l	Same
Print full screen	CSI ?19 h	Same
Print scrolling region	CSI ?19 l	Same
Print screen	CSI 0 i or CSI i	Same
Send screen	CSI 2 i	Same
Transparent print mode off	CSI 4 i	Same
Transparent print mode on	CSI 5 i	Same
PR port receive mode off	CSI 6 i	Same
PR port receive mode on	CSI 7 i	Same
Select parallel printer	CSI 8 i	Same
Select serial printer	CSI 9 i	Same
Print line	CSI ?1 i	Same
Send line	CSI ?3 i	Same
Copy print mode off	CSI ?4 i	Same
Copy print mode on	CSI ?5 i	Same
Transmit form feed after send screen operation	CSI 1	Same
No form feed after send screen operation	CSI 0	Same
Send characters at cursor	ESC 5	Same
Send answerback message	CTRL E	Same
Suspend transmission	CTRL S	Same
Resume transmission	CTRL Q	Same
More Terminal Control Commands		
Display screen adjustment pattern	ESC # 8	Same
Sound bell, if enabled	BEL (CTRL G)	Same
Abort escape sequence; no character displayed ³	CAN (CTRL X)	Same
Abort escape sequence; display reverse question mark [^]	SUB (CTRL Z)	Same
Initiate escape sequence	ESC (CTRL [])	Same
Next Page	CSI U	Same
Preceding Page	CSI V	Same
Terminal Resets		
Soft terminal reset	CSI ! p	Same
Hard terminal reset	ESC c	Same
Terminal Status Reports		
Request primary attributes report	CSI 0 c or ESC Z	Same
Request secondary attributes report	CSI > 0 c	Same
Respond with current revision	CSI > 1; 20; 0c	Same
Request terminal status report	CSI 5 n	Same
Respond terminal functioning and ready	CSI 0 n	Same
Request cursor position report	CSI 6 n	Same
Respond cursor at line l, column c	CSI l; c R	Same
Request printer status report	CSI ?15 n	Same
Respond printer ready	CSI ?10 n	Same
Respond printer not ready	CSI ?11 n	Same
Respond printer not connected	CSI ?13 n	Same
Request function key status report	CSI ?25 n	Same
Respond key definitions not locked	CSI ?20 n	Same
Respond key definitions locked	CSI ?21 n	Same

Table 9- Supported VT100, VT220 and Console ANSI Commands, Cont'd

FUNCTION	Command	
	VT100, VT220	Console ANSI
Request keyboard status report	CSI ? 26 n	Same
Respond with keyboard language	CSI ? 27; Ps n	Same

Ps	Keyboard Language	Ps	Keyboard Language
1	U. S.	6	Spanish
2	U. K.	7	Swedish
3	Danish	8	Norwegian
4	German	9	Italian
5	French		

- *1. More than one mode, but less than 17, may be set with one sequence. Enter multiple numeric parameters separated by semicolons (;). However you cannot combine sequences containing "?" with those that don't contain "?", nor can you combine sequences ending with "h" with those ending with "l".
- *2. To toggle monitor mode from the keyboard, press CTRL SHIFT 1 (use the 1 on the numeric keypad).
- *3. In VT52 or VT100 modes, displays checkerboard character.

4.5.2 VT52 Command Guide

Table 10- VT52 Mode Escape Sequences

Command	VT52
Move cursor up one line	ESC A
Move cursor down one line	ESC B
Move cursor right one column	ESC C
Move cursor left one column	ESC D
Move cursor to home position	ESC H
Move cursor up one line with scroll	ESC I
Move cursor to line <i>line</i> , column <i>col</i>	ESC Y <i>line col</i>
Select graphics character set	ESC F
Select U.S. ASCII character set	ESC G
Erase from cursor to end of display	ESC J
Erase from cursor to end of line	ESC K
Print cursor line	ESC V
Print display	ESC]
Transparent print mode on	ESC W
Transparent print mode off	ESC X
Copy print mode on	ESC ^
Copy print mode off	ESC _
Keypad application mode on	ESC =
Keypad application mode off	ESC >
Enter VT100 mode	ESC <
Identify terminal	ESC Z

4.6 Using Printer Server via Ethernet Connection

Introduction

In order to send print jobs to a network-based printer, the Ethernet Print Terminal function in the TERMINAL must be used. To use this function, the Telnet Terminal communication option described on page 1 is available. For this option to work, an Ethernet cable must be connected as described on page 6.

There are two ways to send the print jobs to a network-connected printer: 1) through LPD protocol, and 2) through TFTP protocol.

- The LPD method is more suitable for printing environments with a large number of users because the LPD protocol has a queue process so print jobs will be kept in the print queues in the CPU.
- TFTP does not implement the print queue concept; if the printer port is not ready for accepting new print jobs, TFTP will be terminated. Consequently, the user must send the print job again. As a result, the TFTP protocol is suitable for printing small jobs, in an environment with a small number of users, or for testing purposes.

LPD is a built-in printing protocol in the BSD type of UNIX and is also available in most other UNIX systems. With LPD, users do not need to install additional software to the CPU to print the jobs. Most implementations of the LPD protocol send out the data file before the control file. However, since Ethernet Print Terminal must print the data file immediately upon receiving it, the print option specified in the control file cannot take effect.

To install the printer server function of Ethernet Print Terminal, the first step is Basic setup. Whichever printing protocol will be used, it is necessary to run basic setup first. If LPD will be used to print jobs, go through the Setup for LPD procedures. If TFTP will be used, go through the Setup for TFTP procedures.

4.6.1 Basic Setup

Because the TCP/IP world uses IP addressing to communicate with each other, the purpose of Basic Setup is to assign an IP address to the Ethernet Print Terminal.

For the purpose of this explanation, assume the following:

- (1) Login to the UNIX CPU as root
- (2) The Ethernet Print Terminal is on the same network segment that the printer resides.

Step 1. Add the Print Server to /etc/hosts

Create a new entry in the /etc/hosts file on all UNIX CPUs that are slated to work with Ethernet Print Terminal. To create a new entry, add the following line:

```
IP_Address PS_NAME # comment
```

where: IP_Address is an IP address.
PS_NAME is a CPU name of a print server.
The statement after # is the comment for the new entry.

e.g. 90.3.2.2 ETPS1 # Ethernet Terminal

This example assigns the name ETPS1 to the Ethernet Print Terminal with IP address 90.3.2.2.

NOTE: The IP address is defined in setup Screen of Ethernet Print Terminal, as a Local IP address. Use the same one.

Step 2. Check to see if above steps are completed

To verify if the IP address of print Server function is installed successfully, issue the following ping command:

```
ping PS_NAME [Enter]
```

e.g. ping ETPS1 [Enter]

4.6.2 Setup for LPD

Follow those steps from step 1 to step 2 described in Basic Setup. The following steps are dependent on the operating system. Please refer to the UNIX administration guide. The following illustrated steps are under BSD system.

Step 3. Create a spooling directory

Use mkdir command to create a directory for spooling.

e.g. mkdir/usr/spool/ETPS1

Step 4. Make the directory available to LPD main process

Basically, the method has the following three procedures:

- 1) Assign the spooling daemon as the owner of this directory.
- 2) Allow the spooling daemon to be able to read from or write to the directory.
- 3) Enable the group of LPD main processes to be able to read from or write to the directory.

e.g. If it works on a BSD UNIX host and makes the directory /usr/ spool/ETPS1 (created in step 3) available, then follow these three procedures:

```
chown daemon /usr/spool/ETPS1
chmod 775 /usr/spool/ETPS1
chgrp daemon /usr/spool/ETPS1
```

Step 5. Add a remote printer

To add a remote printer, insert a block similar to the following in the /etc/printcap file.

```
Printer_name|Remote Printer on Ethernet Terminal:\
:lp=\
:rm=PS_NAME:\
:rp=Logic_Printer_name:\
:sd=<full path of spooler directory name>:\
```

e.g. If Ethernet Print Terminal works on a BSD UNIX host, then insert the following block into /etc/printcap file.

```
ETPS1|Remote Printer on Ethernet Terminal:\
:lp=\
:rm=ETPS1:\
:rp=L1:\
:sd=/usr/spool/ETPS1:\
```

Step 6. Start CPU's print mechanism for BSD version UNIX system

Typing: lpc start printer_name [Enter]

e.g. lpc start ETPS1 [Enter]

Now the Ethernet Print Terminal is configured to accept LPD printing..

4.6.3 LPD printing

LPD protocol is built-in to most of the UNIX system. However, detailed implementation of LPD differs among UNIX systems. Please refer to the UNIX administration guide for reference. The following illustrated printing command is under BSD system or System V version.

For BSD system: `lpr -P <printer_name><filename>`
For System V version: `lp -d <printer_name><filename>`

This command is to print selected file to the selected printer.

e.g. `lpr -PETPS1 /etc/hosts` (BSD version) or `lp -dETPS1 /etc/hosts` (System V version)
This example is to print the `/etc/hosts` file to the Ethernet Print Terminal printer.

4.6.4 Setup for TFTP

When working on the BSD UNIX system, run the setup procedure under Setup for LPD on page 61. Otherwise run the Setup for LPD omitting step 6.

4.6.5 TFTP Printing

Before using TFTP printing, the Ethernet Print Terminal needs to be installed completely by Setup for TFTP (above). TFTP Printing lets the user send print jobs to the printers directory. There are no spooling mechanisms involved. Consequently, if that printer is not ready, the TFTP process will be terminated immediately without sending print jobs to printers. The user must make sure the printer is ready to print before issuing the TFTP command to have a successful result.

Log into the Ethernet Print Terminal with this command:

```
tftp <PS_NAME>
```

and then type:

```
put <file Name> Ln
```

where Ln is a logic printer for L1 to L8

e.g. `tftp ETPS1`
`tftp > put /etc/hosts L1`

This example prints the `/etc/hosts` file to the logic printer 1 of Ethernet Print Terminal printer ETPS1.

4.7 On-Screen Display (OSD)

4.7.1 Standard Controls

The RACKMUX LCD has 5 standard control buttons and a power LED. The 5 standard control buttons operate as follows:

- The **Power** button turns the RACKMUX LCD and backlight ON and OFF as desired.
- The **Power LED** located immediately below the Power button is a dual color LED. It will illuminate with a green color when the RACKMUX is powered ON and working properly. It will illuminate with a red color if the RACKMUX is powered ON but there is no input signal detected. The LED will illuminate red only momentarily just before turning OFF.
- The **Menu** button is used to bring up the OSD menu where the various settings of the LCD display can be adjusted. Once the OSD screen is displayed, the Menu button is used to make selections within the menus. See "OSD Control Menu " (below) for more on LCD display settings.
- The **Up and Down Arrow** buttons are used to navigate through the menus. Move the cursor up or down as desired to highlight an item for selection. Once an item is highlighted, pressing the Menu button will select it.

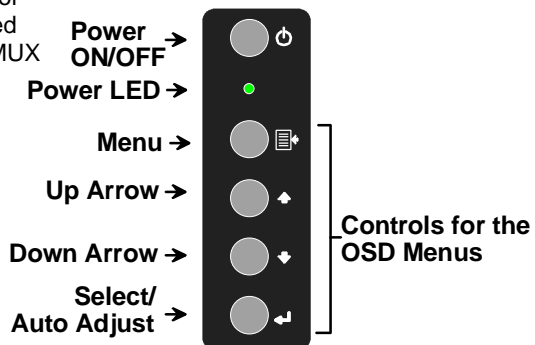

Figure 26- OSD Controls

- The **Select** button is used to make selections within the OSD menus when the OSD menu is ON. When the OSD menu is OFF, the Select button will act as an **Auto Adjust** button to keep the user from having to use the menus to adjust the quality of the image on the monitor.

4.7.2 OSD Control Menu

The OSD (On Screen Display) Menu enables the user to select the desired characteristics of the LCD display. To activate the OSD Menu, press the Menu button (above). To turn the Menu back OFF, either select "EXIT" from the main menu or just wait 10-60 seconds and it will automatically be cleared from the screen.

4.7.2.1 OSD Main Menu

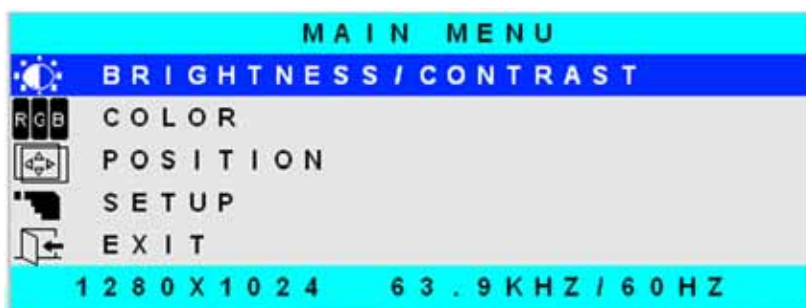

Selection	Purpose	Range
Brightness/Contrast	Increase/decrease panel brightness/contrast level	1-100
Color	R,G,B color temperature control	1-100
Position	<ul style="list-style-type: none"> • Auto Adjust • Video Image horizontal and vertical position control • Clock setting • Phase control 	1-100
Setup	<ul style="list-style-type: none"> • Control OSD Image position on screen • Set time OSD will stay on screen before auto shutoff • Select the language of the OSD menu 	-- 10 to 60 seconds Several languages (see page 40)
Exit	Exit from the OSD control menu	

4.7.2.2 Brightness/Contrast Menu

Selecting the Brightness/Contrast menu will bring up a screen in which the user can adjust the brightness and contrast levels of the LCD display. With either the BRIGHTNESS or CONTRAST sections highlighted, (use the Up or Down arrow to move between them), press the Select button to choose the option to adjust. Then use the Up or Down Arrow to adjust the setting. Select EXIT when finished to return to the Main Menu.



4.7.2.3 Color Menu

Selecting the Color menu will bring up a screen in which the user can adjust the Red, Green, and Blue color levels (values from 1-100) of the LCD display. With either the RED, GREEN, or BLUE sections highlighted, (use the Up or Down arrow to move between them), press the Select button to choose the option to adjust. Then use the Up or Down Arrow to adjust the setting. Select EXIT when finished to return to the Main Menu.

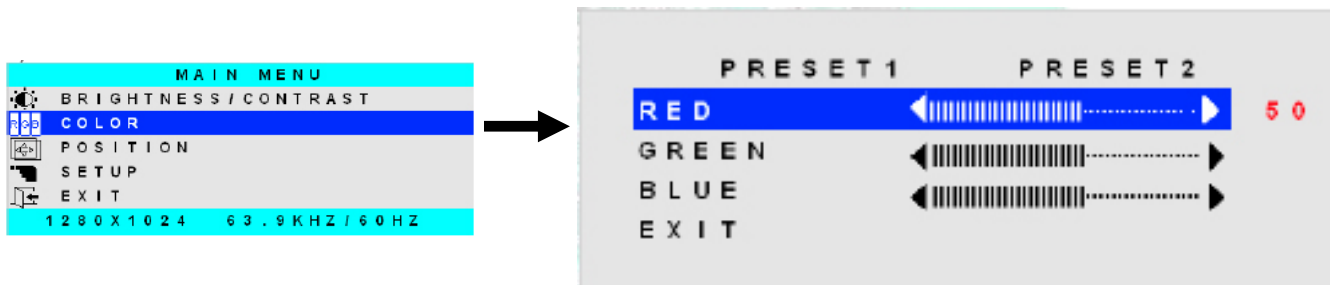

4.7.2.4 Position Menu

Selecting the Position menu will bring up a screen in which the user can select AUTO ADJUST to automatically adjust the horizontal and vertical position of the displayed image on the monitor, as well as adjust the clock and phase settings if they are not correct. The user can also individually adjust these settings if so desired. With either of the sections highlighted, (use the Up or Down arrow to move between them), press the Select button to choose the option to adjust. Then use the Up or Down Arrow to adjust the setting as needed. Select EXIT when finished to return to the Main Menu.

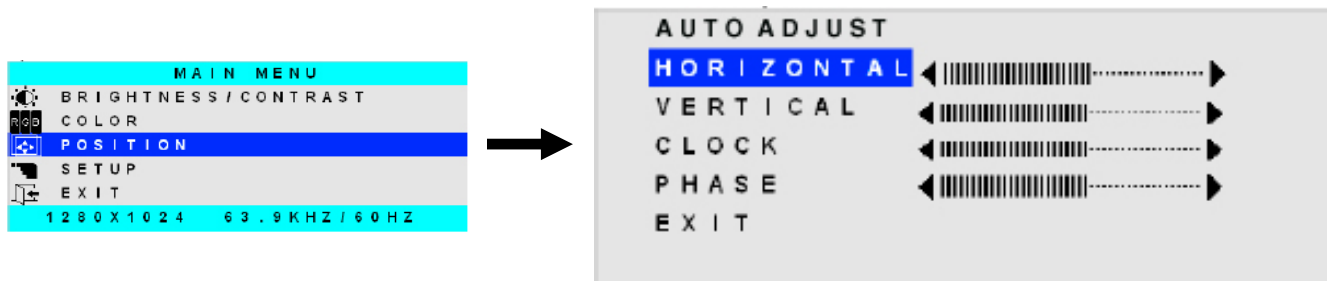

4.7.2.5 Setup Menu

Selecting the Setup menu will bring up a screen in which the user can adjust

- OSD POSITION-the position of the OSD menus on the LCD display
- OSD TIME-the length of time the user can be idle before the OSD menu automatically exits (adjustable from 10 to 60 seconds)
- LANGUAGE-the language that the OSD menus will be presented in

With the item highlighted, (use the Up or Down arrow to move between them), press the Select button to choose the option to adjust. Then use the Up or Down Arrow to adjust the setting as needed. Select EXIT when finished to return to the Main Menu.

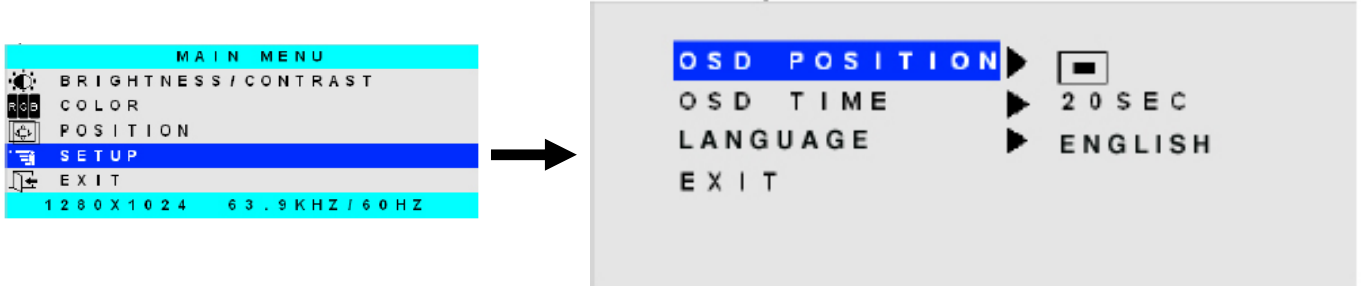

OSD Image can be moved to different points on the display

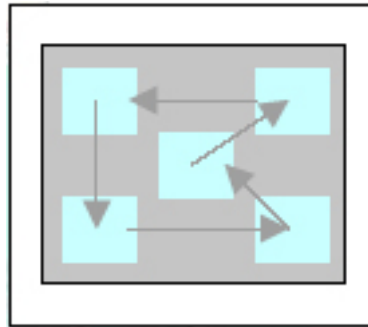

4.8 Keyboard Functions

The keyboard on the RACKMUX has a standard condensed Windows format. To reduce the keyboard size, some keys have been assigned multiple functions, accessible via the "Fn" key. This section will describe which keys have multiple functions and how to enable them.

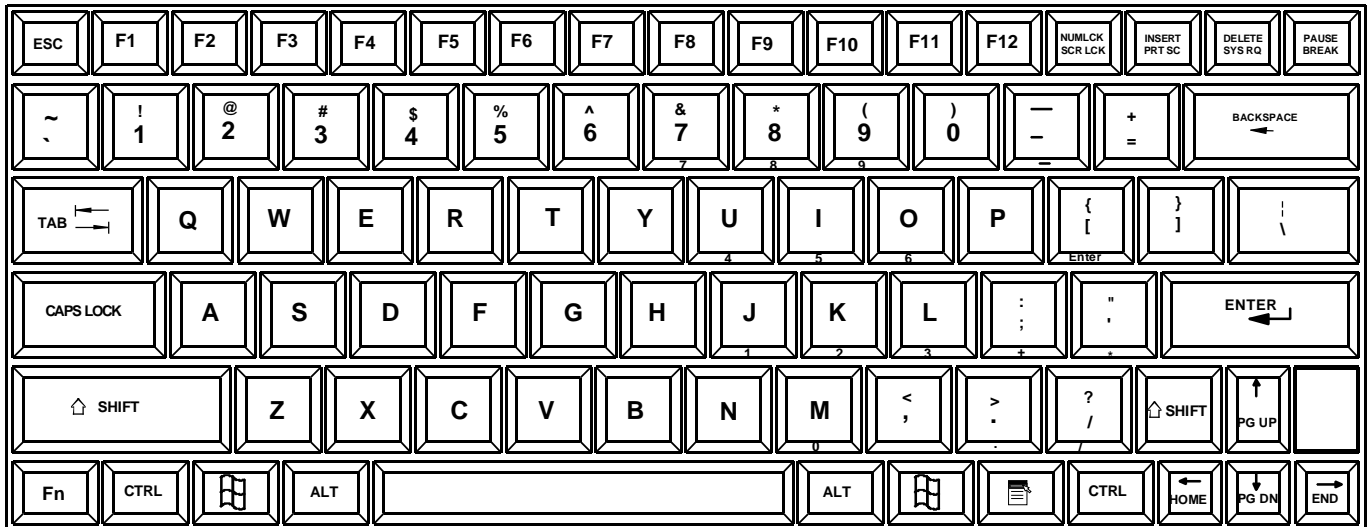

↑
"Fn" Key to enable additional key functions

Figure 27- Keyboard Layout

4.8.1 Number Pad

The functionality of a Number Pad on a standard Windows keyboard has been incorporated into this keyboard. To substitute the keys of the Number Pad

1. Press the "NumLock" key. The NumLock LED () will illuminate.
2. Press the "Fn" key. This will lock the "Fn" key (until pressed again). The "Fn" LED will illuminate.

With the Fn and NumLock LEDs illuminated, pressing some standard keys will result in displaying characters as indicated in the chart below.

Table 11- Number Pad Keys

Standard Key	Displayed when NumLock is ON	Function when NumLock is OFF
j	" 1 "	End
k	" 2 "	Down Arrow
l	" 3 "	Page Down
u	" 4 "	Left Arrow
i	" 5 "	
o	" 6 "	Right Arrow
7	" 7 "	Home
8	" 8 "	Up Arrow
9	" 9 "	Page Up
m	" 0 "	Insert
.	" . "	Delete
(period)	(period)	
/	" / "	---
(forward slash)	(forward slash)	
;	" + "	---
(semicolon)	(plus sign)	
'	" * "	---
(apostrophe)	(asterisk)	
-	-	---
(hyphen)	(minus sign)	
[ENTER (function)	---
(left bracket)		

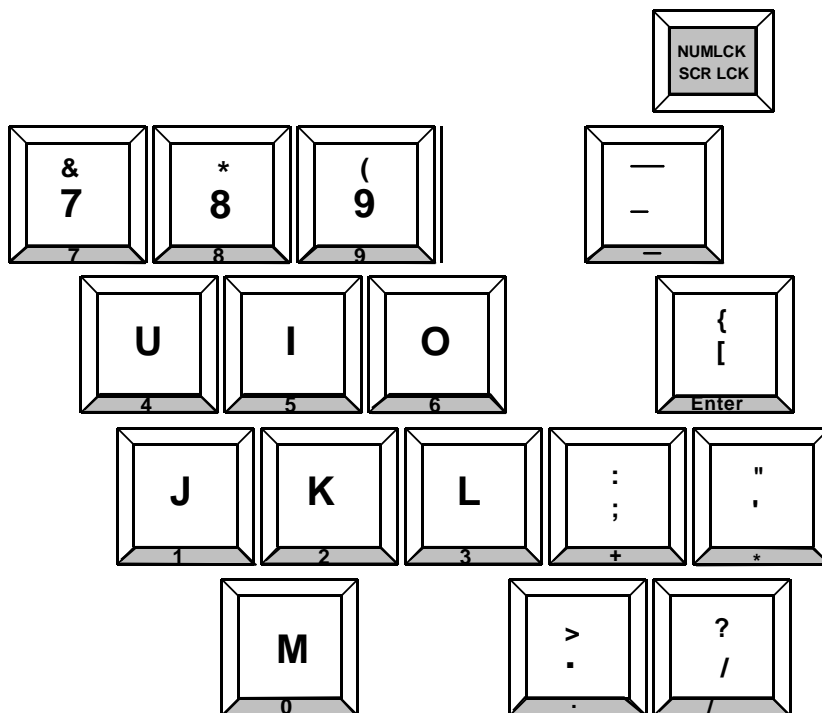

Figure 28- Keys of the Number Pad

5. HARDWARE INFORMATION

Introduction

This chapter provides information on hardware specifications, pinouts for the Ethernet cable, pinouts for port connectors, and pinouts for the cable adapters.

5.1 Hardware Specifications: TERMINAL

Physical	
Size (In.) WxDxH	19x18.4x1.75
Weight	23.3 lbs.
Temperature	0°~38°C operating, -30°~60°C storage
Humidity	17% to 96% non condensing
Power Supply	Auto -ranging 90-262 VAC, 47-63Hz
Power Consumption	60W (max), <25W (standby)
Cables Included	Power (IEC320), 5 foot DC power supply
Rack mount kit	Included for Sun & most EIA 19" racks
LCD Panel Specifications	
Screen size	15.1" visible diagonal
Resolution	800x600
Controls	contrast, brightness, auto-adjust, color temperature
Brightness	250cd/m (typical)
Contrast	500:1 (typical)
Viewing Angle	140° H / 125° V
Keyboard Specifications	
Type	83 key
Layout	US
Terminal Emulation	
Emulations	VT52, VT100, VT220, Console ANSI, PC TERM, TVI910+/925, WY-50+, WY-60, WY-100, WY-120, WY-325, PCG Alpha
Character matrix	7x12 dot matrix in 10x16 cell with 3 dot descenders
Screen size	80x25
Page length	1, 2, or 4 screens (multiple screen page length reduces maximum number of possible telnet sessions)
Cursor	Blink or steady, block or underline
Modes	Full duplex, half duplex, block mode, half block mode
Color modes	16 foreground and 16 background colors
Communication Ports	
Network port	One RJ45 10Base-T Ethernet port
Local printer ports	One DB25F Parallel and one DB9M RS232 port
Serial baud rates	50 to 115,200 bps
Data format	7 or 8 data bits with or without parity, 1 or 2 stop bits
Serial handshake	XON/XOFF, XPC, and hardware DTR
Communications options	Single RS232 server connection, or up to 16 Ethernet telnet sessions to predefined IP addresses. Both serial and Ethernet connections can not be used concurrently.

5.2 Hardware Specifications: SERIMUX

Attribute	Value
Operating temperature	40°F to 120°F (5°C to 50°C)
Storage temperature	-20°F to 140°F (-29°C to 60°C)
Humidity	10% to 90% non-condensing
Power supply External	100 - 240VAC, 50/60 Hz, 1.0A (max)
Power consumption	DC input: 0.8A/5VDC, 4.5 W (typical), 8W (max)
Operating system	Linux Hard Hat embedded
SDRAM	64 megabytes
Flash memory	8 megabytes

5.3 CPU-to-RACKMUX Ethernet Crossover Cable

In order to make a direct connection between a CPU and the ETHERNET connector of the RACKMUX, a crossover cable must be used. The cable is made with CAT5 cable terminated with RJ45 connectors and wired according to the chart below.

Pin assignment at Standard End	Wire Color	Pin assignment at Crossed End
1	White/Orange	3
2	Orange	6
3	White/Green	1
4	Blue	4
5	White/Blue	5
6	Green	2
7	White/Brown	7
8	Brown	8

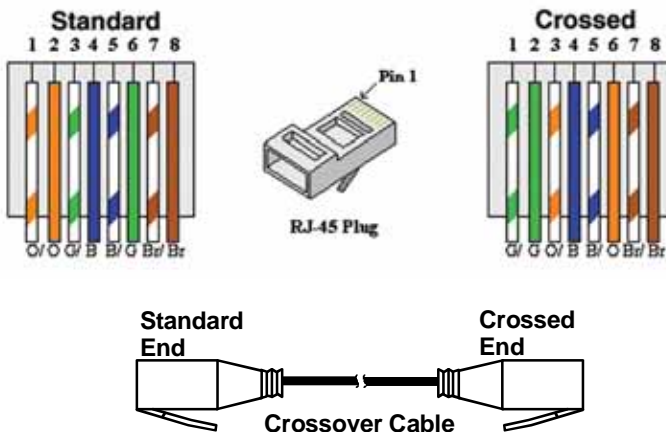

5.4 Serial Port Cabling

The SERIMUX simplifies cabling. The RJ45 8-pin configuration matches all SUN and Cisco RJ45 console port configurations, enabling CAT 5 cabling without pinout concerns. Three DB-25 and one DB-9 adapters come in the package. A DB-25 male, a DB-25 female, and a DB-9 adapter support console management applications. A DB-25 male adapter provides a modem connection. See the cable adapter information that follows later in this chapter.

Note: The cable length restrictions common to RS-232 cables apply to the SERIMUX serial cable as well.

5.5 Serial Port Pinouts

The SERIMUX uses an RJ45 connector for serial ports. Pin assignments are as follows:

SERIMUX Ports

Pin	Description
1	CTS
2	DSR
3	RxD
4	GND
5	DCD: Note Inbound signal can also be used as a second ground.
6	TxD
7	DTR
8	RTS

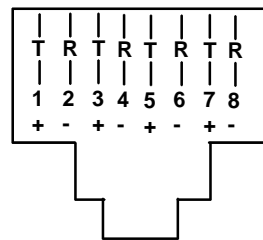

Mating face of an RJ45 Female

5.6 Cable Adapters

The SERIMUX comes with four cable adapters. The following illustrations show cable adapter pin outs. Additional adapters can be purchased from NTI.

DB-25 Male Console Adapter (NTI P/N DB25M-RJ45F-T)

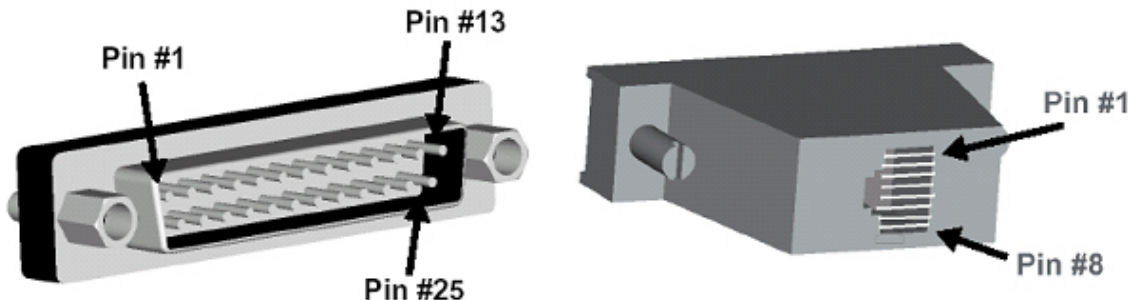

DB-25 Male to RJ45 Connector Pin Assignments

RJ45	Signal	Connected to	DB-25M	Signal
1	CTS	Connected to	4	RTS
2	DSR		20	DTR
5	DCD			
3	RxD	Connected to	2	TxD
4	GND	Connected to	7	GND
6	TxD	Connected to	3	RxD
7	DTR	Connected to	6	DCD
			8	DSR
8	RTS	Connected to	5	CTS

DB-9 Female Console Adapter (NTI P/N DB9F-RJ45F)

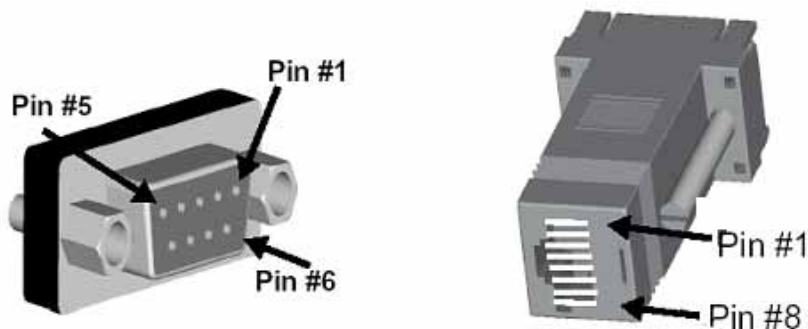

DB-9 Female to RJ45 Pin Assignments

RJ45	Signal	Connected to	DB-9F	Signal
1	CTS	Connected to	7	RTS
2	DSR		4	DTR
5	DCD			
3	RxD	Connected to	3	TxD
4	GND	Connected to	5	GND
6	TxD	Connected to	2	RxD
7	DTR	Connected to	1	DCD
			6	DSR
8	RTS	Connected to	8	CTS

DB-25 Female Console Adapter (NTI P/N DB25F-RJ45F)

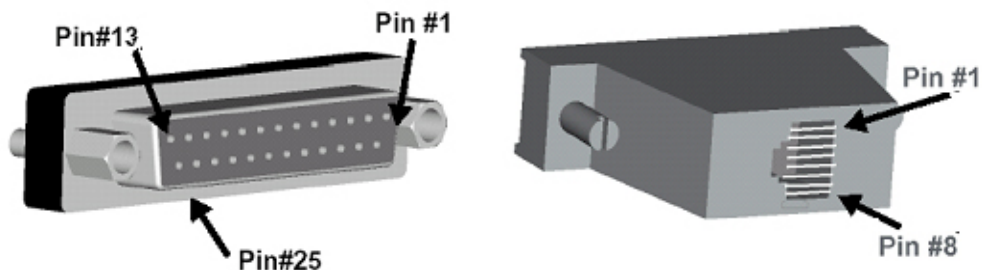

DB-25 Female to RJ45 Pin Assignments

RJ45	Signal		DB-25F	Signal
1	CTS	Connected to	4	RTS
2	DSR	Connected to	20	DTR
5	DCD			
3	RxD	Connected to	2	TxD
4	GND	Connected to	7	GND
6	TxD	Connected to	3	RxD
7	DTR	Connected to	6	DCD
			8	DSR
8	RTS	Connected to	5	CTS

DB-25 Male Modem Adapter (NTI P/N DB25M-RJ45F-C)

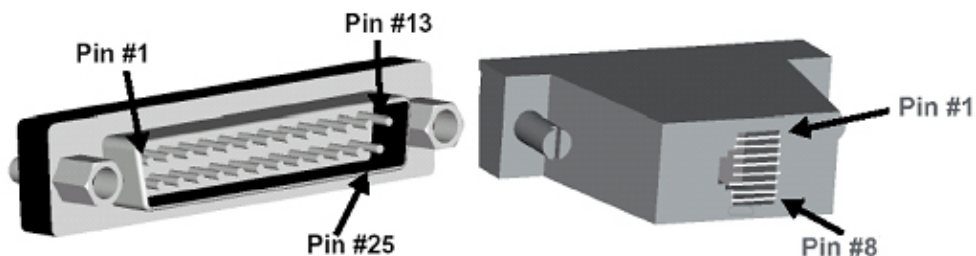

DB-25 Male Modem to RJ45 Pin Assignment

RJ45	Signal		DB-25M	Signal
1	CTS	Connected to	5	CTS
2	DSR	Connected to	6	DSR
3	RxD	Connected to	3	RxD
4	GND	Connected to	7	GND
5	DCD	Connected to	8	DCD
6	TxD	Connected to	2	TxD
7	DTR	Connected to	20	DTR
8	RTS	Connected to	4	RTS

5.7 SERIMUX Ethernet Pinouts

The SERIMUX uses a standard Ethernet connector for device connections, that is a shielded and compliant with AT&T 258 specifications.

Pin	Description
1	Tx+
2	Tx-
3	Rx+
4	NC
5	NC
6	Rx-
7	NC
8	NC

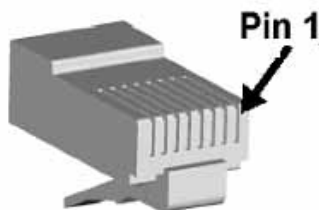

5.8 TERMINAL Connector Pin Assignments

Serial Port (Serial 2) Connector Pin Assignments (RS232C 9-pin connector)

Pin	Signal	Mnemonic Direction
1	Data carrier detect	DCD In
2	Receive data	RxD In
3	Transmit data	TxD Out
4	Data terminal ready	DTR Out
5	Signal ground	SGND
6	Data set ready	DSR In
7	Request to send	RTS Out
8	Clear to send	CTS In

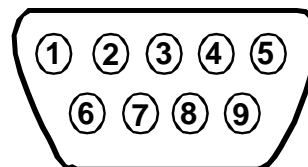

Mating Face of 9D Male

Printer Port Connector Pin Assignments (Compatible with the IBM PC parallel port)

Pin	Signal	Mnemonic Direction
1	-Strobe	Out
2	Data bit 0	Out
3	Data bit 1	Out
4	Data bit 2	Out
5	Data bit 3	Out
6	Data bit 4	Out
7	Data bit 5	Out
8	Data bit 6	Out
9	Data bit 7	Out
10	-Acknowledge	In
11	Busy	In
12	Paper end	In
13	Slct	In
14	-Auto feed XT	Out
15	-Error	In
16	-Init	Out
17	-Slctn	Out
18-25	Ground	Out

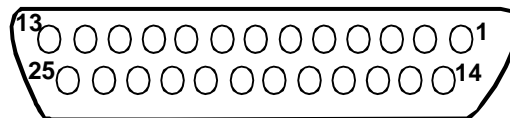

SUB-D 25 female connector

Ethernet Connector Pin Assignments (RJ45 8 pin female connector)

Pin	Signal	Direction
1	Transmit +	Out
2	Transmit -	Out
3	Receive +	In
6	Receive -	In

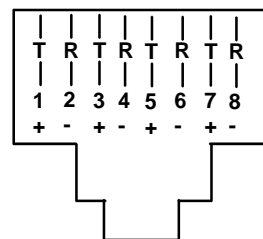

Mating face of an RJ45 Female

5.9 Dimensional Drawings

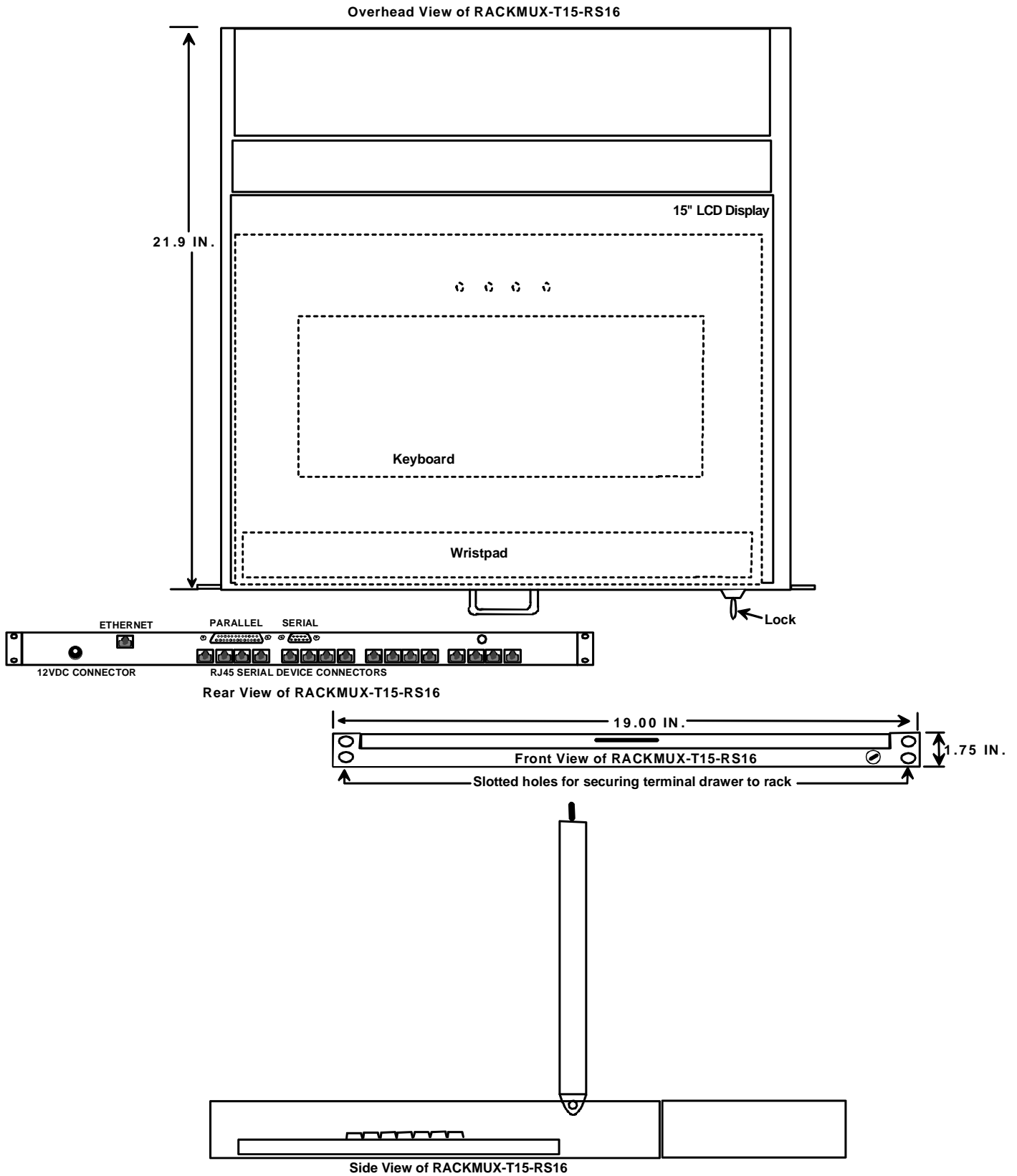

INDEX

- access to ports, 22
- Administrator password**, 23
- ASCII commands, 41
- BSD UNIX system, 62
- cable adapters, 70
- cabling, 69
- change administrator password, 23
- Configure the terminal**, 8
- connect to SERIMUX.
- connectors, 6
- Console Terminal**, 1
- control buttons, 63
- crossover cable, 69
- Crossover cable, 7
- Default settings**, 9,30, 33
- dimensional drawings, 73
- ENH, 41
- Ethernet, 7
- Ethernet Print Terminal, 60
- Firmware menu, 24
- Fn key, 66
- host list, 26
- keyboard, 66
- Keyboard commands**, 40
- LAN, 7
- login, 11, 12
- login-user, 26
- LPD method, 60
- materials supplied, 3
- Modem settings**, 18
- mount to a rack, 5
- Number Pad**, 67
- OSD menus, 63
- password**, 11
- port access, 22
- Port List, 13
- Port serial settings**, 16
- port settings, 14
- printer connection, 6
- programmable keys, 36
- quick start, 8
- Remote System Control**, 1
- reset button, 4, 30
- ROOT**, 12
- RS-232 Emulations, 1
- setup directory, 8
- Specifications**, 68
- SSH Console Switch, 2
- SUN Microsystems, 1
- telnet, 1
- terminal drawer, 1
- TERMINAL setup, 8, 32
- Terse mode, 29
- TFTP printing, 62
- user list, 20
- User main menu**, 27
- user settings, 21
- VT100, 52
- VT220, 52
- VT52, 59
- Wyse, 41

WARRANTY INFORMATION

The warranty period on this product (parts and labor) is one (1) year from the date of purchase. Please contact Network Technologies Inc at **(800) 742-8324** (800-RGB-TECH) or **(330) 562-7070** or visit our website at <http://www.networktechinc.com> for information regarding repairs and/or returns. A return authorization number is required for all repairs/returns.