

**F<sup>2</sup>MC FAMILY**  
**PARALLEL COMMUNICATIONS ADAPTER**  
**MB2142-03**  
**HARDWARE MANUAL**



**F<sup>2</sup>MC FAMILY**  
**PARALLEL COMMUNICATIONS ADAPTER**  
**MB2142-03**  
**HARDWARE MANUAL**



# PREFACE

## ■ Objectives and Intended Readers

The MB2142-03 support tool (parallel communications adapter) is designed to enable the development and evaluation of products based on the F<sup>2</sup>MC\* family.

The MB2142-03 is connected to the main unit (MB2141A).

This enables the main unit to perform parallel communication with the host machine (such as a personal computer).

This manual describes the handling and connection of the MB2142-03. It is aimed at engineers responsible for the development of products based on the F<sup>2</sup>MC, using the MB2142-03.

Refer to the following related manual as necessary:

- Related manual

F<sup>2</sup>MC FAMILY MB2140series MAIN UNIT (MB2141A) HARDWARE MANUAL

\*: F<sup>2</sup>MC stands for FUJITSU Flexible Microcontroller.

## ■ Structure of This Manual

This manual consists of the following two chapters. Familiarize yourself with the contents of this manual before attempting to use the adapter.

### **CHAPTER 1 "HANDLING AND SPECIFICATIONS OF THE PRODUCT"**

Describes the handling and specifications of the parallel communications adapter.

### **CHAPTER 2 "CONNECTIONS"**

Describes the connections and the power-on and power-off sequences of the parallel communications adapter.

1. The contents of this document are subject to change without notice. Customers are advised to consult with FUJITSU sales representatives before ordering.
2. The information and circuit diagrams in this document are presented as examples of semiconductor device applications, and are not intended to be incorporated in devices for actual use. Also, FUJITSU is unable to assume responsibility for infringement of any patent rights or other rights of third parties arising from the use of this information or circuit diagrams.
3. The contents of this document may not be reproduced or copied without the permission of FUJITSU, Ltd.
4. FUJITSU semiconductor devices are intended for use in standard applications (computers, office automation and other office equipment, industrial, communications, and measurement equipment, personal or household devices, etc.).

**CAUTION:**

*Customers considering the use of our products in special applications where failure or abnormal operation may directly affect human lives or cause physical injury or property damage, or where extremely high levels of reliability are demanded (such as aerospace systems, atomic energy controls, sea floor repeaters, vehicle operating controls, medical devices for life support, etc.) are requested to consult with FUJITSU sales representatives before such use. The company will not be responsible for damages arising from such use without prior approval.*

5. Any semiconductor devices have an inherent chance of failure. You must protect against injury, damage or loss from such failures by incorporating safety design measures into your facility and equipment such as redundancy, fire protection, and prevention of over-current levels and other abnormal operating conditions.
6. If any products described in this document represent goods or technologies subject to certain restrictions on export under the Foreign Exchange and Foreign Trade Law of Japan, the prior authorization by Japanese government will be required for export of those products from Japan.

# CONTENTS

<b>CHAPTER 1</b>	<b>HANDLING AND SPECIFICATIONS OF THE PRODUCT</b>	<b>1</b>
1.1	Packing List	2
1.2	Parallel Communications Adapter Specifications	4
1.2.1	Electrical Characteristics of I/O Signal Lines	5
1.2.2	Connector Pin Assignment	6
1.3	IF Cable Specifications	8
1.4	Notes on Use	10
<b>CHAPTER 2</b>	<b>CONNECTIONS</b>	<b>11</b>
2.1	System Configuration	12
2.2	Connection to Main Unit	13
2.3	Connection to Host Machine	15
2.4	Power-on Sequence	17
2.5	Power-off Sequence	18
<b>INDEX</b>		<b>19</b>





# CHAPTER 1    HANDLING AND SPECIFICATIONS OF THE PRODUCT

---

**This chapter explains the handling and specifications of the parallel communications adapter. Read this chapter and check the contents of the package before attempting to use the parallel communications adapter.**

---

- 1.1 "Packing List"
- 1.2 "Parallel Communications Adapter Specifications"
- 1.3 "IF Cable Specifications"
- 1.4 "Notes on Use"

## 1.1 Packing List

---

**Before first using the parallel communications adapter, check that the package contains the following components:**

- **Parallel communications adapter x 1**
  - **IF cable x 1**
- 

### ■ Appearance and Names of Parts

Figure 1.1-1 "Parallel Communications Adapter" illustrates the parallel communications adapter. For details of the connections, see CHAPTER 2 "CONNECTIONS."

The function of each part is described below:

IF connector: Used to connect the IF cable.

Parallel communications connector: Used to connect the printer cable.

Obtain a printer cable that is suitable for the host machine (such as a personal computer).

Figure 1.1-1 Parallel Communications Adapter

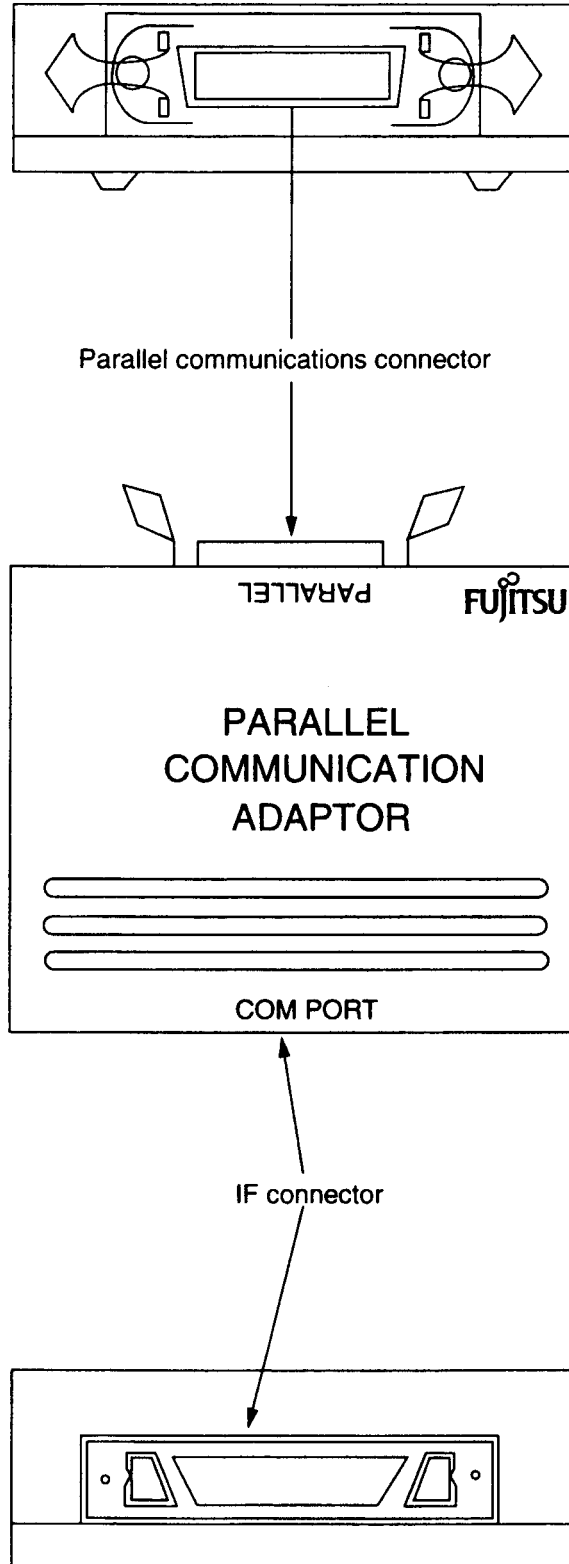

## 1.2 Parallel Communications Adapter Specifications

**Table 1.2-1 "Parallel Communications Adapter Specifications" lists the specifications of the parallel communications adapter.**

### ■ Parallel Communications Adapter Specifications

Table 1.2-1 "Parallel Communications Adapter Specifications" lists the specifications of the parallel communications adapter.

**Table 1.2-1 Parallel Communications Adapter Specifications**

Item	Contents
Name	Parallel communications adaptor
Model	MB2142-03
Power supply	Voltage: +5 V plus or minus 5% Current: 1A (max.) <sup>*1</sup>
Operating temperature	0 to +55 degrees Celsius
Operating humidity	30% to 80% (non-condensing)
Dimensions	120mm (W) x 90mm (D) x 26mm (H) <sup>*2</sup>
Weight	200g approx.

\*1: Power is supplied from the main unit.

\*2: Not including projections.

### ■ Parallel Communications Specifications

The parallel communications format conforms to the Centronics interface.

An Amphenol 36P connector is used as the parallel communications connector.

The electrical characteristics of the I/O signal lines are described in Section 1.2.1 "Electrical Characteristics of I/O Signal Lines"

## 1.2.1 Electrical Characteristics of I/O Signal Lines

Figure 1.2-1 "Electrical Characteristics of I/O Signal Lines" shows the electrical characteristics of the I/O signal lines.

### ■ Electrical Characteristics of I/O Signal Lines

The signal levels of the I/O signal lines are indicated below. Figure 1.2-1 "Electrical Characteristics of I/O Signal Lines" shows the electrical characteristics.

"L": 0 to +0.4 V

"H": +2.4 to +5.0 V

The power supply signal is directly connected to +5 V.

Figure 1.2-1 Electrical Characteristics of I/O Signal Lines

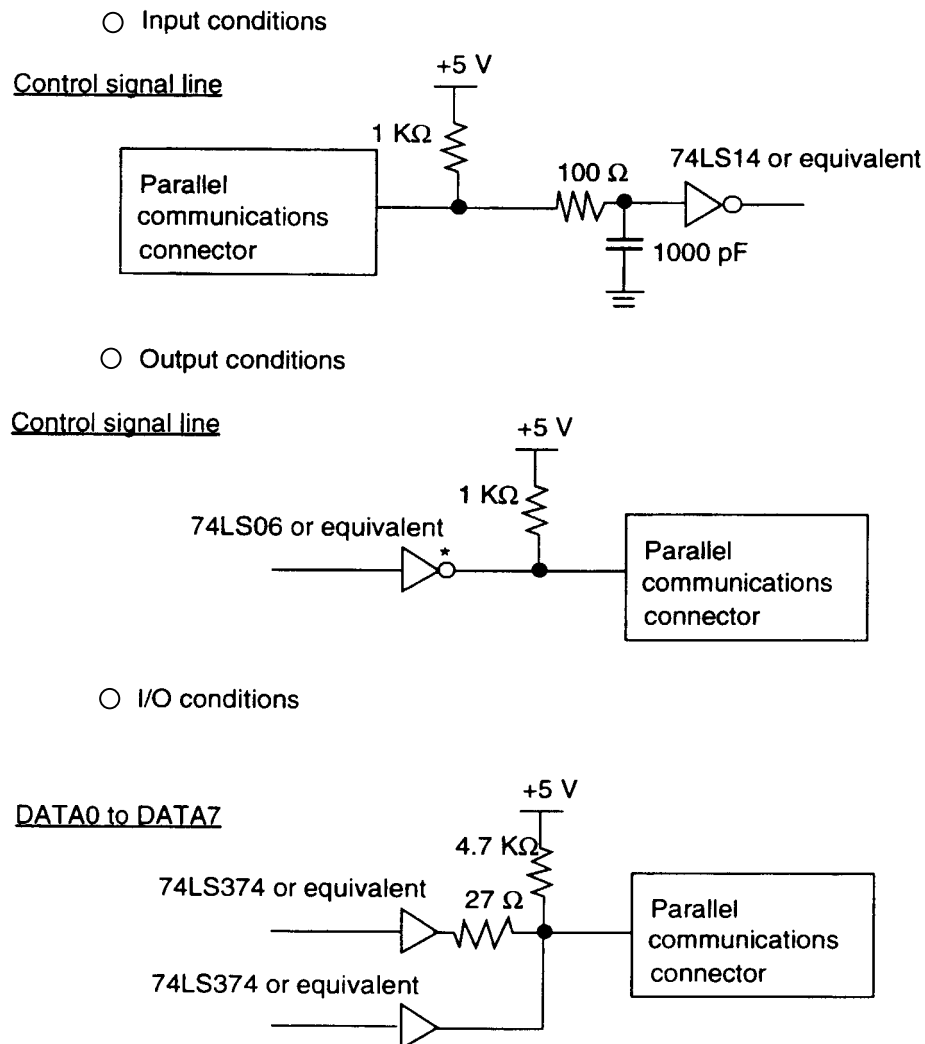

## 1.2.2 Connector Pin Assignment

---

An Amphenol 36P connector is used as the parallel communications connector. Table 1.2-2 "Parallel Communications Connector Signal Line Names" lists the connector signal line names.

---

### ■ Connector Pin Assignment

The model and pin assignment of the connector are described below.

- Connector model  
57LE-40360-7700 (D12) Manufactured by DDK, or equivalent  
(Generally referred to as Amphenol 36P)
- Connector pin assignment <viewed from the cable insertion side>

Figure 1.2-2 "Parallel Communications Connector Pin Assignment" shows the pin assignment. Table 1.2-2 "Parallel Communications Connector Signal Line Names" lists the signal line names.

**Figure 1.2-2 Parallel Communications Connector Pin Assignment**

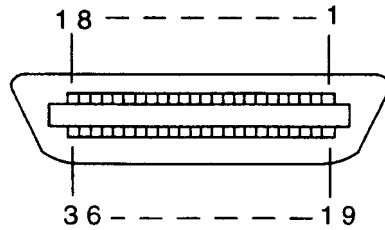

## 1.2 Parallel Communications Adapter Specifications

**Table 1.2-2 Parallel Communications Connector Signal Line Names**

No.	Signal line	I/O	Function	No.	Signal line	I/O	Function
1	$\overline{\text{DSTB}}$	I	Data strobe signal	19	GND	-	Signal grounding
2	DATA 0	I/O	Data	20	GND	-	Signal grounding
3	DATA 1	I/O	Data	21	GND	-	Signal grounding
4	DATA 2	I/O	Data	22	GND	-	Signal grounding
5	DATA 3	I/O	Data	23	GND	-	Signal grounding
6	DATA 4	I/O	Data	24	GND	-	Signal grounding
7	DATA 5	I/O	Data	25	GND	-	Signal grounding
8	DATA 6	I/O	Data	26	GND	-	Signal grounding
9	DATA 7	I/O	Data	27	GND	-	Signal grounding
10	$\overline{\text{ACK}}$	O	Acknowledge signal	28	GND	-	Signal grounding
11	BUSY	O	Busy signal	29	GND	-	Signal grounding
12	PE	O	No paper	30	GND	-	Signal grounding
13	SLCT	O	Select signal, output	31	$\overline{\text{INIT}}$	I	Reset signal
14	NC	-	Unused	32	$\overline{\text{ERR}}$	O	Error signal
15	NC	-	Unused	33	NC	-	Unused
16	GND	-	Signal grounding	34	NC	-	Unused
17	FG	-	Frame grounding	35	NC	-	Unused
18	+5 V	O	Power supply signal	36	$\overline{\text{SLCTIN}}$	I	Select signal, input

## 1.3 IF Cable Specifications

---

Table 1.3-1 "IF Cable Components" lists the IF cable components, Table 1.3-2 "IF Cable General Specifications" lists the general specifications of the IF cable, and Figure 1.3-1 "IF Cable Dimensions" shows the dimensions of the IF cable.

---

### ■ IF Cable Specifications

For details of the connection to the main unit, see Section 2.2 "Connection to Main Unit."

**Table 1.3-1 IF Cable Components**

Part Name	Remarks
FCN-237R068-G/E connector x 2	Fujitsu
FCN-230C068-C/E cover x 2	Fujitsu

**Table 1.3-2 IF Cable General Specifications**

Item		Contents
Rated current		DC1A
Temperature	Operating	-10 to +60 degrees
	Storage	-10 to +60 degrees



Figure 1.3-1 IF Cable Dimensions

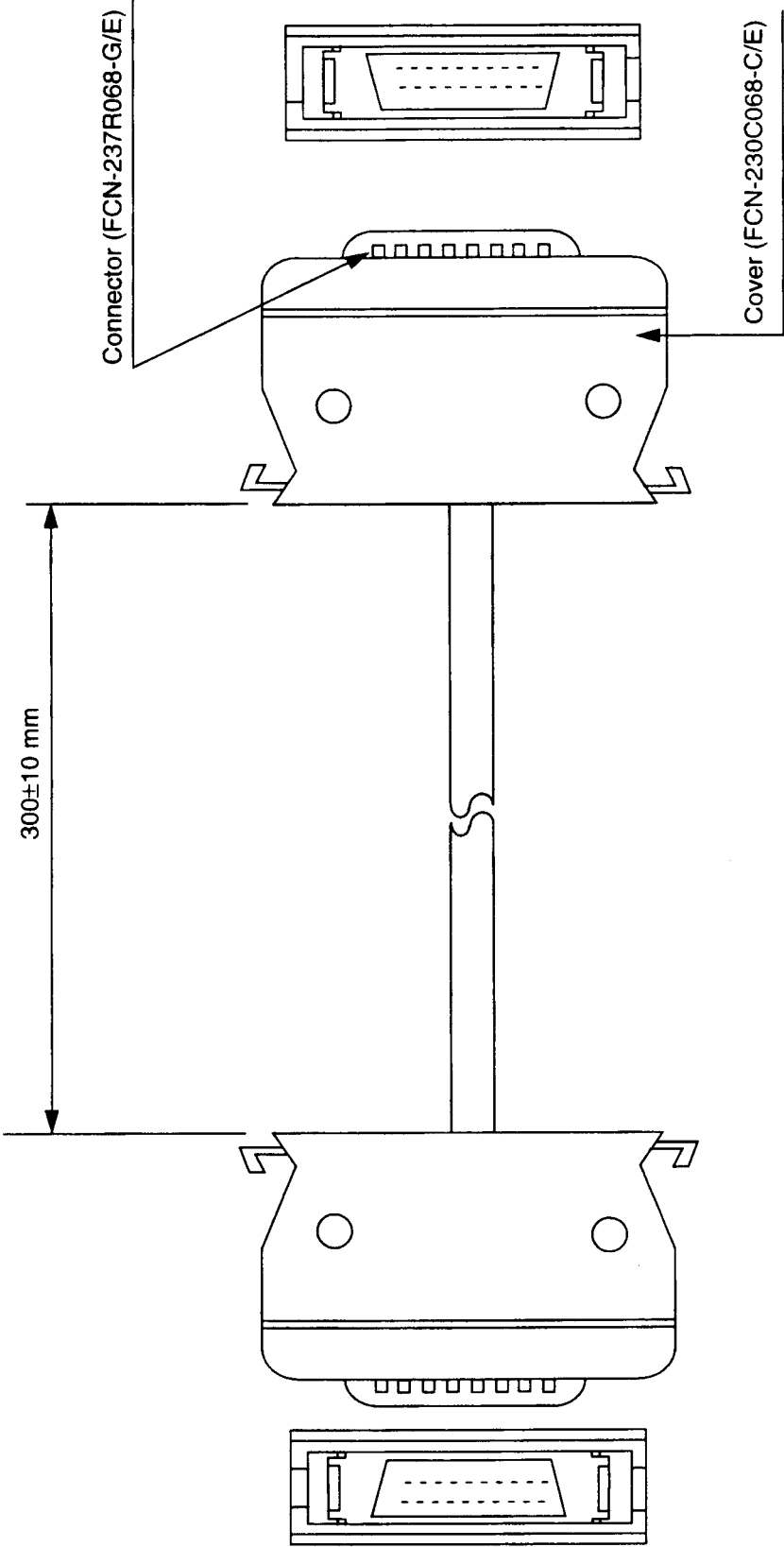

## 1.4 Notes on Use

---

**When using the parallel communications adapter, keep the following notes in mind.**

---

### ■ Notes on Use

When using the parallel communications adapter, keep the following notes in mind:

- Turn off the power before connecting or removing a cable.
- To remove a cable, do not pull the cable itself; grasp and pull the connector.
- To prevent electrostatic destruction, be careful not to touch the connector pins, and prevent the connector pins from touching any objects.
- Refer to this manual for details of setting and usage.

### ■ Storage

When storing the parallel communications adapter, keep the following notes in mind:

- Take whatever measures are necessary to prevent the parallel communications adapter from being jolted or jarred in storage.
- Do not expose the parallel communications adapter to direct sunlight, high temperatures, high humidity, or condensation.
- Do not keep the parallel communications adapter in an intense electrical or magnetic field for an extended period.

Table 1.4-1 "Storage Environment" lists the storage temperature and humidity.

**Table 1.4-1 Storage Environment**

<b>Storage temperature</b>	<b>Storage humidity</b>
-20 to +70 degrees	20% to 90% (non-condensing)

# CHAPTER 2 CONNECTIONS

---

**This chapter describes how to connect, turn on, and turn off the parallel communications adapter. Familiarize yourself with the contents of this chapter before turning on the adapter.**

---

- 2.1 "System Configuration"
- 2.2 "Connection to Main Unit"
- 2.3 "Connection to Host Machine"
- 2.4 "Power-on Sequence"
- 2.5 "Power-off Sequence"

## 2.1 System Configuration

---

Connecting the parallel communications adapter to the host machine enables parallel communication with the host machine.

---

### ■ System Configuration

Connecting the parallel communications adapter to the host machine enables parallel communication with the host machine.

Figure 2.1-1 "System Configuration" shows the hardware system configuration when using the parallel communications adapter.

Figure 2.1-1 System Configuration

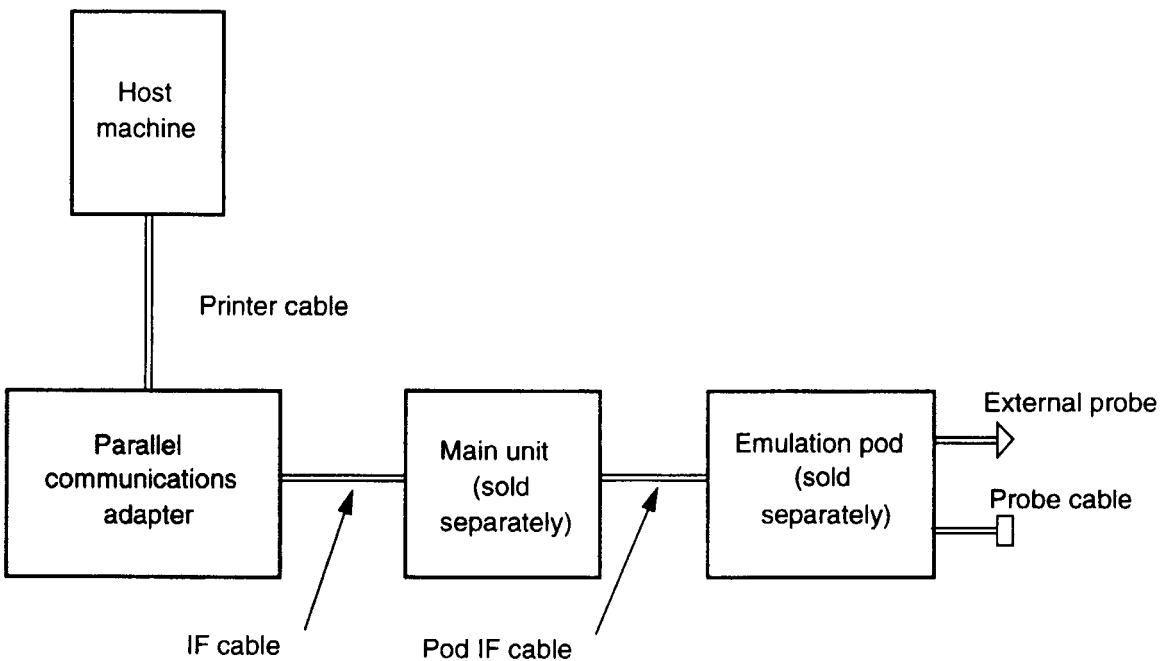

## 2.2 Connection to Main Unit

---

As shown in Figure 2.2-1 "IF Cable Connection", use an IF cable to connect the parallel communications adapter to the main unit (sold separately).

---

### ■ Connection to Main Unit

As shown in Figure 2.2-1 "IF Cable Connection", use an IF cable to connect the parallel communications adapter to the main unit (sold separately).

For details of connecting the IF cable to the main unit, refer to the 2140 Main Unit MB2141 Emulator User's Manual.

### ■ Notes

When connecting the parallel communications adapter to the main unit (sold separately), keep the following points in mind:

- Turn off the power before connecting or removing a cable. Attempting to connect or remove a cable while the power is turned on may cause a malfunction.
- To remove a cable, do not pull the cable itself; grasp and pull the connector. Pulling the cable itself may cause a conductor inside the cable to break.

Figure 2.2-1 IF Cable Connection

Parallel communications adapter

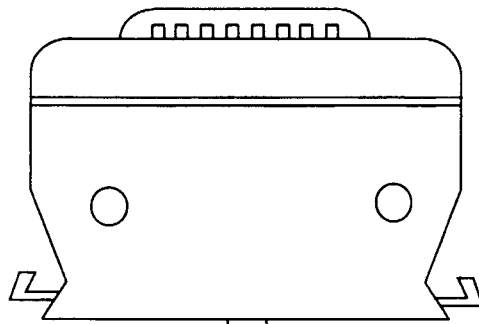
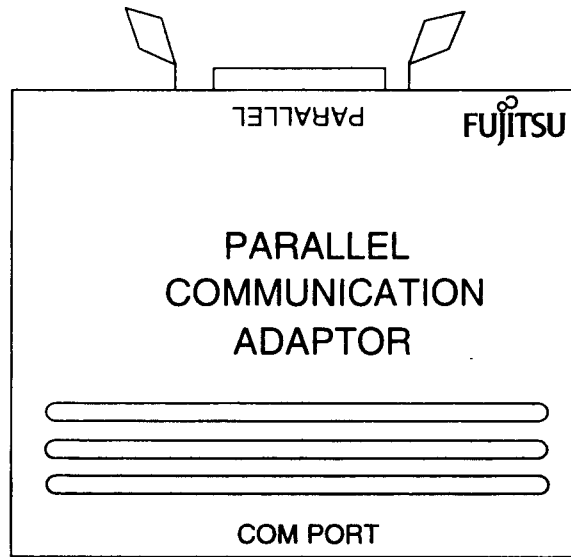

IF cable

Main unit

## 2.3 Connection to Host Machine

---

As shown in Figure 2.3-1 "Printer Cable Connection", use the printer cable (sold separately) to connect the parallel communications adapter to the host machine.

---

### ■ Connection to Host Machine

As shown in Figure 2.3-1 "Printer Cable Connection", use the printer cable (sold separately) to connect the parallel communications adapter to the host machine.

For details of how to connect the printer cable (sold separately) to the host machine, refer to the manual for the host machine.

### ■ Notes

When connecting the parallel communications adapter to the host machine, keep the following notes in mind:

- Turn off the power before connecting or removing a cable. Attempting to connect or remove a cable while the power is turned on may cause a malfunction.
- To remove a cable, do not pull the cable itself; grasp and pull the connector. Pulling the cable itself may cause a conductor inside the cable to break.

Figure 2.3-1 Printer Cable Connection

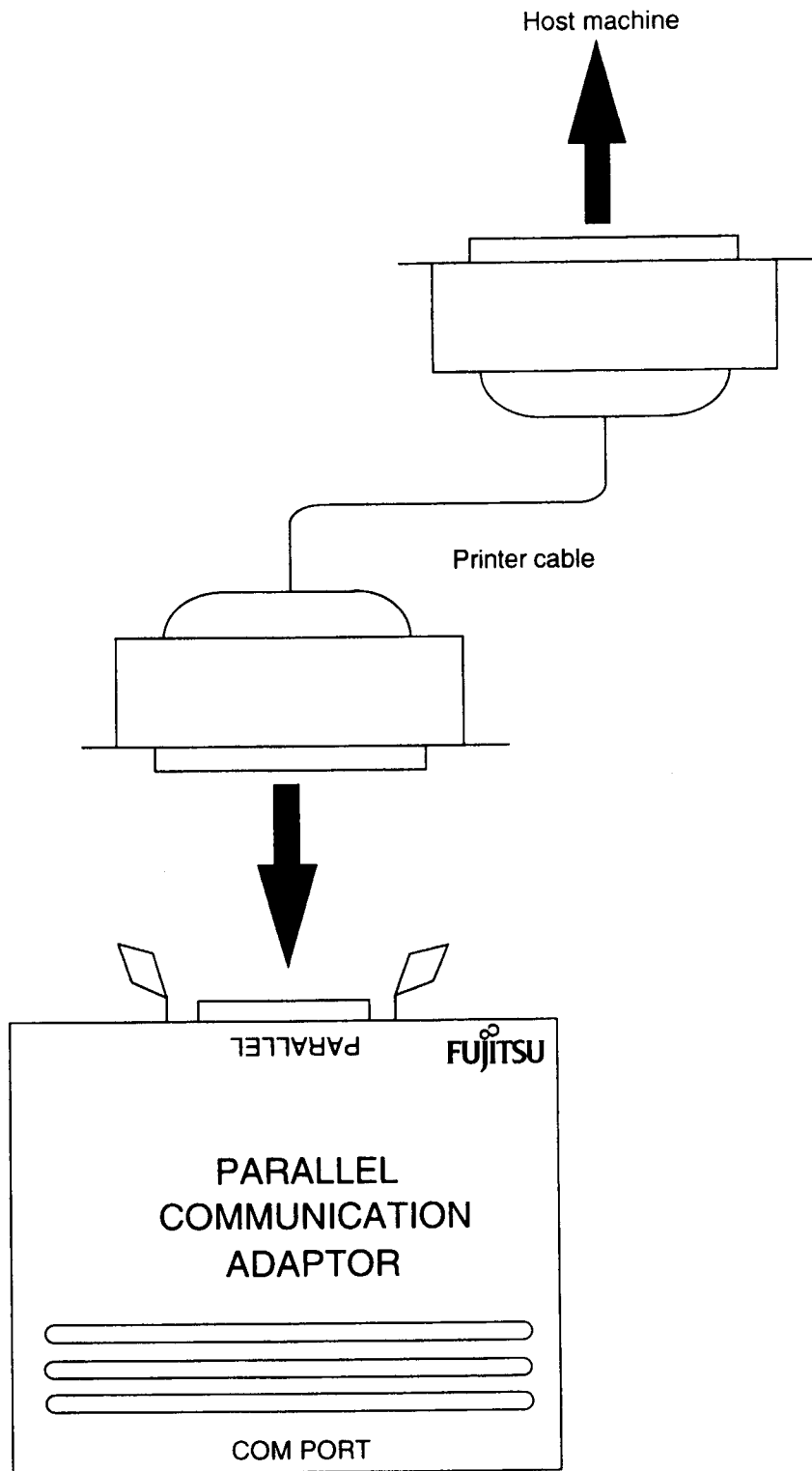

Parallel communications adapter



## 2.4 Power-on Sequence

---

**Before turning on the power, ensure that all connections are complete. Then, turn on the power in the order of the host machine, the main unit, then the target (user system).**

---

### ■ Power-on Sequence

Before turning on the power, ensure that all connections are complete. Then, turn on the power in the order of the host machine, the main unit, then the target (user system).

To turn on the power, set the power switch on the rear panel of the main unit to "1". Turning on the main unit also turns on the parallel communications adapter.

## 2.5 Power-off Sequence

---

**Turn off the power in the order of the target (user system), the main unit, then the host machine.**

---

### ■ Power-off Sequence

Turn off the power in the order of the target (user system), the main unit, then the host machine.

To turn off the power, set the power switch on the rear panel of the main unit to "0". Turning off the main unit also turns off the parallel communications adapter.

# INDEX

---

**The index follows on the next page.  
This is listed in alphabetic order.**

---

# Index

<b>A</b>		<b>N</b>	
appearance and name of part .....	2	note .....	13, 15
		note on use .....	10
<b>C</b>		<b>P</b>	
connection to host machine .....	15	parallel communication adapter specification .....	4
connection to main unit .....	13	parallel communication specification .....	4
connector pin assignment .....	6	power-off sequence .....	18
		power-on sequence .....	17
<b>E</b>		<b>S</b>	
electrical characteristic of I/O signal line .....	5	storage .....	10
		system configuration .....	12
<b>I</b>		<b>U</b>	
I/O signal line, electrical characteristic of .....	5	use, note on .....	10
IF cable specification .....	8		

CM41-00413-2E

---

**FUJITSU SEMICONDUCTOR • CONTROLLER MANUAL**  
F<sup>2</sup>MC FAMILY  
PARALLEL COMMUNICATIONS ADAPTER  
MB2142-03  
HARDWARE MANUAL

---

January 2001 the second edition

Published **FUJITSU LIMITED** Electronic Devices

Edited Technical Communication Dept.

---

FUJITSU



FUJITSU SEMICONDUCTOR F<sup>2</sup>MC FAMILY PARALLEL COMMUNICATIONS ADAPTER MB2142-03 HARDWARE MANUAL