

## User's Manual



**Cable Cubby® 200**  
**Cable Cubby® 300C**  
**Cable Cubby® 300S**  
**Cable Cubby® 600**  
**Cable Cubby® 800**

**Surface Access Products for Cables, AAPs, and Power Outlets**



www.extron.com

**Extron Electronics, USA**  
1230 South Lewis Street  
Anaheim, CA 92805  
USA  
714.491.1500  
Fax 714.491.1517

**Extron Electronics, Europe**  
Beeldschemweg 6C  
3821 AH Amersfoort  
The Netherlands  
+31.33.453.4040  
Fax +31.33.453.4050

**Extron Electronics, Asia**  
135 Joo Seng Road, #04-01  
PM Industrial Building  
Singapore 368363  
+65.6383.4400  
Fax +65.6383.4664

**Extron Electronics, Japan**  
Kyodo Building  
16 Ichibancho  
Chiyoda-ku, Tokyo 102-0082 Japan  
+81.3.3511.7655  
Fax +81.3.3511.7656

## 安全须知 • 中文



这个符号提示用户该设备用户手册中的操作和维护说明。



这个符号警告用户该设备机壳内暴露的危险电压，有触电危险。

### 注意

**阅读说明书** • 用户使用该设备前必须阅读并理解有安全和使用说明。

**保存说明书** • 用户应保存安全说明书以备将来使用。  
**遵守警告** • 用户应遵守产品和用户指南上的所有安全和操作说明。

**避免追加** • 不要使用该产品厂商没有推荐的工具或追加设备，以避免危险。

### 警告

**电源** • 该设备只能使用产品上标明的电源。设备必用有地线供电系统供电。第三条线（地线）是安设施，不能不用或跳过。

**拔掉电源** • 为安全地从设备拔掉电源，请拔掉所有设备后或桌面电源的电源线，或任何接到市电系统电源线。

**电源线保护** • 妥善布线，避免被踩踏，或重物挤压。

**维护** • 所有维修必须由认证的维修人员进行。设备部没有用户可以更换的零件。为避免出现触电危险不要自己试图打开设备盖子维修该设备。

**通风孔** • 有些设备机壳上有通风槽或孔，它们是用防止机内敏感元件过热。不要用任何东西挡住通风孔。

**锂电池** • 不正确的更换电池会有爆炸的危险。必须使与厂家推荐的相同或相近型号的电池。按照生产厂的议处理废弃电池。

# Table of Contents

---

<b>Chapter One • Introduction</b> .....	1-1
About the Cable Cubby® Products .....	1-2
Features .....	1-5
<b>Chapter Two • Installation</b> .....	2-1
Installation Overview.....	2-2
Preparing the Routing Template .....	2-3
Preparing the Table.....	2-4
Preparing the table with a router.....	2-4
Preparing the table with a hole saw (Cable Cubby 300C only) .....	2-6
Installing the Cables and AAPs .....	2-7
AAP shelf brackets (CC 300, 600, 800) .....	2-7
Installing the power module (CC 300, 600, 800).....	2-8
Installing the cables.....	2-8
Installing the AAPs.....	2-9
Installing the shelf assembly (CC 300, 600, 800).....	2-10
Adjusting the cable position (CC 200) .....	2-10
Mounting the Cable Cubby .....	2-11
<b>Chapter 3 • Maintenance and Modifications</b> .....	3-1
Removing and Replacing the Cable Cubby .....	3-2
Replacing Cables or an AAP .....	3-5
Adding an Additional Power Module (CC 600 and CC 800).....	3-6
<b>Appendix A • Reference Information</b> .....	A-1
Specifications .....	A-2
Cable Cubby Part Numbers .....	A-7
Included Parts .....	A-8
Replacement/Modification Part Numbers .....	A-9
Routing Template Part Numbers .....	A-11
Top Plate Dimensions .....	A-11
<b>Appendix B • Packaging for Shipment</b> .....	B-1



# 1 Chapter One

## **Introduction**

About the Cable Cubby® Products

Features

68-701-01 Rev. F  
06 06

*All trademarks mentioned in this manual are the properties of their respective owners.*

## About the Cable Cubby® Products

The Extron Cable Cubbies are furniture-mounted, architectural solutions for inconspicuous cable access and connection points. When cables are not in use, they can be stored out of the way while remaining connected to the presentation system.

Most US/domestic Cable Cubby models provide two unswitched USA AC power outlets. The US/domestic Cable Cubby 200 provides one outlet. Each of the international versions provides a single unswitched AC power outlet appropriate to the region where the Cable Cubby is sold. Several different types of power receptacles are available for the international version, including UK, French, Israeli, Australian, Indian, European, and Swiss receptacles.

The four different sizes of Cable Cubbies provide room for the indicated number of Extron's Architectural Adapter Plates (AAPs):

- **Cable Cubby 800 USA/domestic model** — Eight single-space (single-height) AAPs
- **Cable Cubby 800 (international model)** — Seven single-space (single-height) AAPs
- **Cable Cubby 600 USA/domestic model** — Six single-space AAPs
- **Cable Cubby 600 (international model)** — Five single-space AAPs
- **Cable Cubby 300 USA/domestic model** — Three single-space AAPs
  - **Cable Cubby 300S** — Square cover (figure 1-1)
  - **Cable Cubby 300C** — Circular (round) cover
- **Cable Cubby 300 (international model)** — Two single-space AAPs
  - **Cable Cubby 300S** — Square cover
  - **Cable Cubby 300C** — Circular (round) cover
- **Cable Cubby 200 (all models)** — Two single-space AAPs

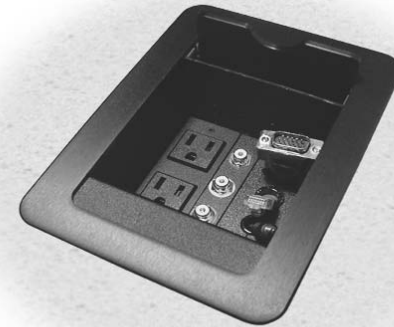

**Figure 1-1 — Cable Cubby 300S US domestic enclosure**

The AAP spaces inside the cubbies allow you to customize the enclosure to meet your unique needs, with the included split double space AAPs and Extron's full line of optional passive AAPs. The split AAPs can store almost any type of cable you might encounter. The line of passive AAPs allows you to customize the AAP with almost any kind of pass-through connectivity you may need.

The elevation of the AAPs inside the cubby and the arrangement of the AAPs and the power outlets are adjustable to suit cable lengths and connector types.

**NOTE** *The elevation and arrangement of the power outlet and AAPs in the Cable Cubby 200 are fixed and not customizable.*

## Introduction, cont'd

The installed Cable Cubbies fit nearly flush within a table or podium top, storing the AAPs and cables out of the way and out of sight. To access the AAPs and connectors, lift the lid (figure 1-2). Half-moon cutouts in the lid allow you to run cables in or out and then close the lid. For Cable Cubby 300s, 600s, and 800s, you can lower the lid into its recessed position.

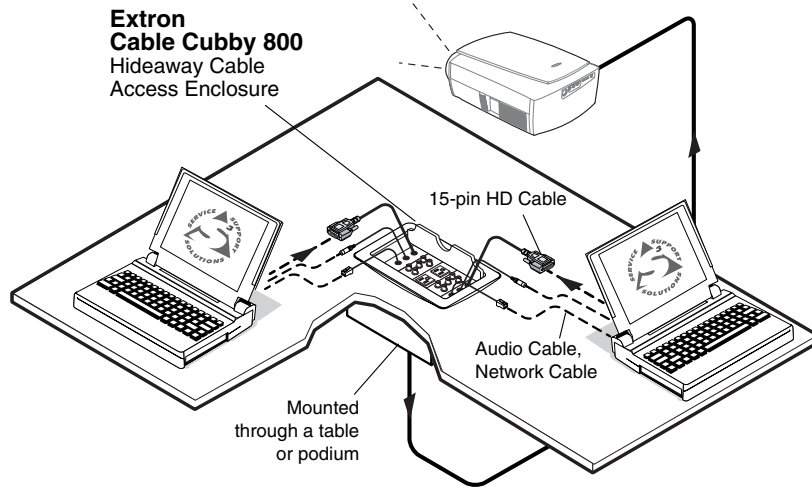

**Figure 1-2 — Typical Cable Cubby 800 application**

The Cable Cubby 300 is available with either a round or a rectangular top. The other cubbies all have rectangular tops only. Preparing the table to install a Cable Cubby 300C (round) requires simply drilling a hole in the table with a 6-inch hole saw (figure 1-3). Preparing the table to install a square cubby requires routing a square hole in the table top. Sheet metal routing templates are available on request for all models at no cost.

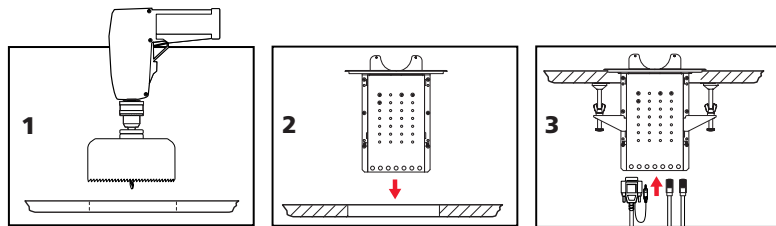

**Figure 1-3 — Cable Cubby 300C mounting**

## Features

- Easy access to cables and AAPs
- Durable mechanical movement
- Cable Cubby 300, 600, and 800 available in a variety of surface finishes
- Compact size
- Flexible installation of Extron passive AAPs
- Grounded AC receptacle(s)
- UL/CUL listing
- CSA certification



# 2 Chapter Two

## **Installation**

Installation Overview

Preparing the Routing Template

Preparing the Table

Installing the Cables and AAPs

Mounting the Cable Cubby

## Installation Overview

Install and set up the Cable Cubby enclosures as follows:

- 1 If you plan to use a mounting template that has not been prepared, prepare the template. See *Preparing the Routing Template*, later in this chapter.
- 2 Cut a hole in the surface where the enclosure will be installed. See *Preparing the Table*, later in this chapter.
- 3 Run all cables necessary to support the AC connector, the cables stored in the cubby, and all planned AAP connectors. Leave enough slack in the cables to connect or route them before the cubby is installed in the table.
- 4 If applicable, install the power module. If your location requires electrical conduit, install an Extron flexible conduit kit. Refer to the *Flexible Conduit Kit Installation Guide*, Extron part #68-734-01.
- 5 Install all desired cables into the cable pass-through (split) AAPs and install the AAPs into the Cable Cubby. See *Installing the Cables and AAPs*, later in this chapter.
- 6 If applicable, connect cables to the rear connectors on the passive AAPs and install the AAPs in the cubby. See *Installing the AAPs*, later in this chapter.
- 7 Mount the Cable Cubby in the table. See *Mounting the Cable Cubby*, later in this chapter.
- 8 Peel the protective film from the top surface.
- 9 Connect the Cable Cubby power cord.

## Preparing the Routing Template

Extron provides metal templates for the Cable Cubbies at no charge. See *Routing Template Part Numbers*, in appendix A, *Reference Information*, for part numbers. Extron recommends using this template as a guide to cut the hole in the table where the cubby will be installed.

**NOTE** *The metal routing template is reusable. Do not discard this template when the installation is complete. Save it for installing Cable Cubby models of the same size.*

- 1 Cut 1/2" x 4" strips of soft, finished lumber at least long enough to span the distance between the desired installation location on the mounting surface and the edges of the mounting surface (figure 2-1).

These strips raise the routing template above the mounting surface to provide room for the router's collar, protect the mounting surface, and extend the routing template's reach so that it can be clamped to the edge of the surface.

**CAUTION** *Do not allow the wood screws to protrude through the bottom of the wooden strips. Protruding screws will mar the table when the template is used.*

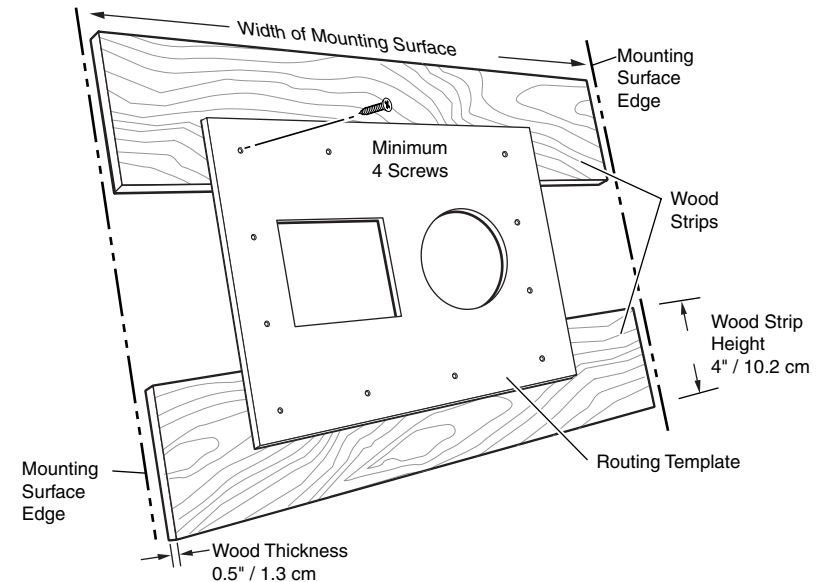

**Figure 2-1 — Prepared CC 300 mounting template**

- 2 Using four or more short wood screws, secure the mounting template to the lumber strips.



### Preparing the Table

The preferred and recommended method for preparing the table for square Cable Cubbies and one of two preferred methods for the Cable Cubby 300C is to use the appropriate Extron routing template and a router.

For the Cable Cubby 300C, another preferred method is to use a 6" hole saw.

Alternatively, for any model, you can use a paper cut-out template (see appendix A) and a sabre saw or keyhole saw, but this method is not recommended.

**CAUTION** *The opening in the table for the Cable Cubby should be cut only by licensed and bonded craftspeople. Exercise care to prevent scarring or damaging the furniture.*

*The surfaces of the Cable Cubby enclosure have screws and other protruding hardware that could damage fine furniture. Do not rest the enclosure on unprotected furniture.*

### Preparing the table with a router

Prepare the table with a router as follows:

**CAUTION** *The routing templates for the various Cable Cubbies are not interchangeable. If you use the wrong template, you will cut an improperly-sized hole. If you use a larger template than required, the cut will result in gaps in the table surface on either side of the enclosure.*

**CAUTION** *Ensure that only the wooden strips on the routing template contact the furniture. Failure to do so may mar the furniture.*

**NOTE** *The metal routing template is reusable. Do not discard the template when the installation is complete. Save it for installing other Cable Cubbies of the same size.*

1. Locate the desired mounting location on the tabletop or other installation surface. Mark the location.
2. Place the mounting template assembly on the table, centered on the mounting location. Angle the template for the optimum positioning. If necessary, use a square to ensure that the template is properly positioned. Extron is not responsible for improperly positioned Cable Cubbies.
3. Once the template assembly is positioned properly, secure the assembly to the table with C-clamps.

**WARNING** *Wear safety glasses when operating the router. Failure to comply can result in eye injury.*

4. Using a router with a 5/8" (or 16 mm) outside diameter guide bushing and a 1/2" (or 12 mm or 12.7 mm) diameter straight router bit, carefully cut the opening in the surface (figure 2-2).

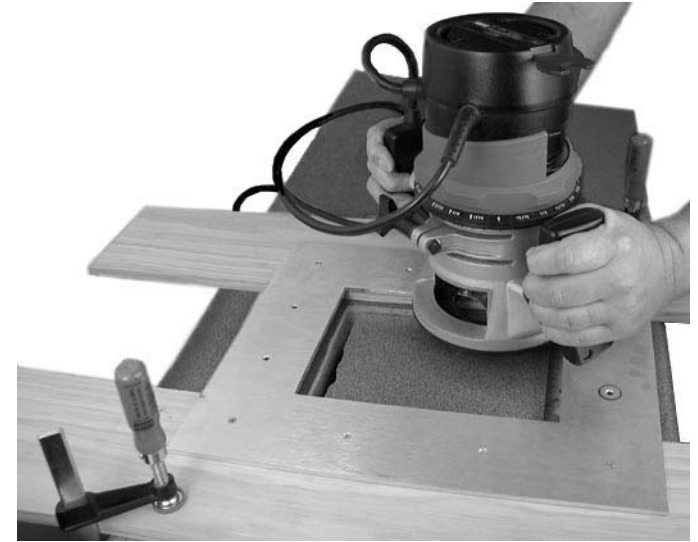

**Figure 2-2 — Cutting the opening with a router**

5. Remove the C-clamps and the routing template.

### Preparing the table with a hole saw (Cable Cubby 300C only)

Prepare the table with a hole saw as follows:

1. On the tabletop or other installation surface, mark the 6" circle, then find and mark the center of the circle.

**WARNING** *Wear safety glasses when operating the drill. Failure to comply can result in eye injury.*

2. Using a portable drill with a 6" (or 152 mm) hole saw, carefully cut the opening in the table surface at the desired location (figure 2-3). Extron is not responsible for improperly positioned Cable Cubbies.

**CAUTION** *Use a portable drill with sufficient power to handle the 6" hole saw. Exercise caution when handling the drill and hole saw. Take care to protect the mounting surface from damage.*

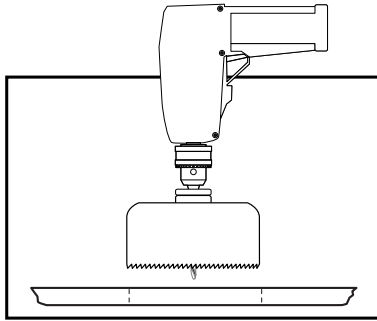

**Figure 2-3 — Cutting the opening with a hole saw**

### Installing the Cables and AAPs

Each Cable Cubby 300, 600, and 800 model ships with one or two moveable AAP shelf assemblies. The Cable Cubby 200's AAP shelf is fixed in place.

#### AAP shelf brackets (CC 300, 600, 800)

Each shipped AAP shelf assembly consists of a set of shelf brackets and a number of cable pass-through (split) AAPs. Depending on the Cable Cubby model, each set of shelf brackets supports either two, three, or four single-space AAPs (figure 2-4).

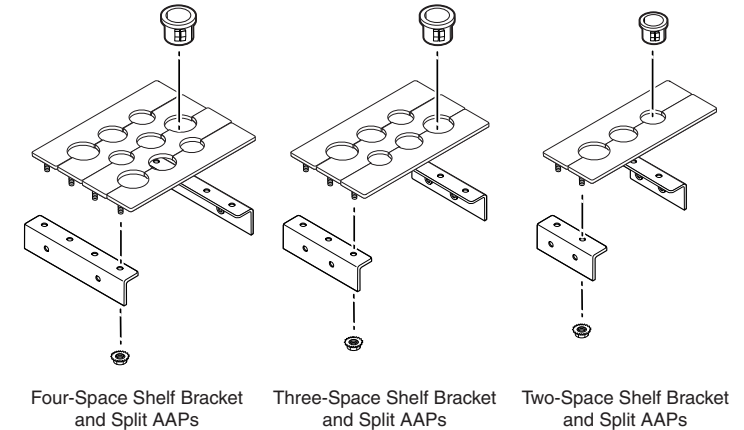

**Figure 2-4 — Shelf brackets**

The simplest way to install the cables and AAPs in the Cable Cubby 300, 600, and 800 is to populate the shelf brackets with split and/or standard AAPs outside the cubby and then install the populated AAP shelf assembly into the cubby.

**NOTE** *Cable cubby 300, 600, and 800 only — On US/domestic models, the power module takes up two AAP spaces. On IEC, EU, Swiss, UK, Israeli, and Australian models, the power module takes up three AAP spaces. Cable pass-through AAPs take two, three, or four AAP spaces. Consider the arrangement of the Cable Cubby AAPs when you install them so that you do not waste AAP space.*

### Installing the power module (CC 300, 600, 800)

From the underside of the Cable Cubby, gently push the power module into the desired position at the desired elevation. Secure the power module into position with four Phillips head screws.

### Installing the cables

Three half-moon cutouts in each set of cable pass-through (split) AAPs loosely channel three cables in the cubby. Each channel is padded with a split grommet to prevent cable wear. Each channel and each associated split grommet is a different size (figure 2-5).

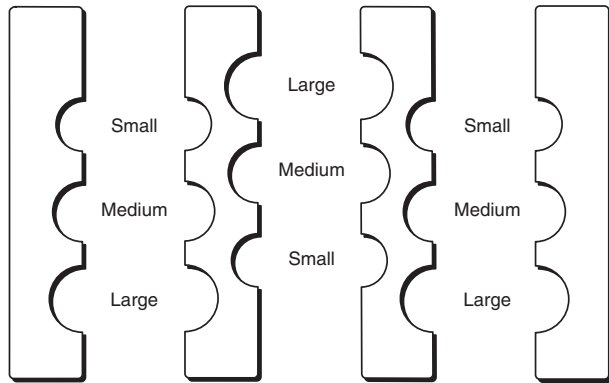

Cable hole	Hole size	Grommet size
Large	0.625" (1.59 cm)	0.453" (1.15 cm)
Medium	0.562" (1.43 cm)	0.390" (0.99 cm)
Small	0.5" (1.27 cm)	0.312" (0.79 cm)

**Figure 2-5 — Cable pass-through AAPs**

A typical installation consists of a VGA cable, an audio cable, and a network cable. In a typical installation, the VGA cable runs in the largest channel, the network cable runs in the middle (medium) channel, and the audio cable runs in the smaller channel. In a non-standard installation, just match the diameter of the cable to the size of the channel as best you can.

Install cables in the channels as follows:

1. Remove a segment of a set of split AAPs by unscrewing the nuts on the underside of the bracket that fastens the plate to the shelf (CC 200) or shelf bracket (CC300, 600, or 800) (figure 2-4, on page 2-7).
2. Rest the cables in the half-moon cutouts of the split AAP segment still mounted on the shelf (CC 200) or shelf brackets (CC 300, 600, and 800). Place the cables so that the connectors that require inside Cable Cubby access protrude from the front (black side) of the split AAP segment.
3. Insert the screws of the split AAP segment that you removed in step 1 through the holes in the shelf bracket. Ensure that the cables are free in the channels that the two split AAP segments form without being pinched where the two segments meet.
4. Secure the split AAP segment to the shelf (CC 200) or shelf brackets (CC 300, 600, and 800) with the provided captive washers and #4-40 nuts.
5. Slip the appropriate size split grommet over each cable with the flange of the grommet toward the connector that will be accessible inside the Cable Cubby. Snap the grommets into the channels.
6. If applicable, snap the included hole plugs into unused channels in place of the split grommets.

### Installing the AAPs

The split AAPs can be replaced with passive Extron AAPs.

Replace a set of split AAPs as follows:

1. Remove the set of split AAPs to be replaced by unscrewing the nuts on the underside the shelf (CC 200) or shelf bracket (CC 300, 600, and 800) that fasten the plates to the bracket (figure 2-4, on page 2-7).
2. Cable the rear of the AAP(s) to be installed before attaching the AAPs to the enclosure.
3. Insert the screws of the AAPs through the holes in the shelf or shelf bracket. Secure the AAPs to the shelf brackets with the provided captive washers and #4-40 nuts.

### Installing the shelf assembly (CC 300, 600, 800)

From the underside of the Cable Cubby, gently push the AAP shelf assembly into the desired position at the desired elevation. Ensure there is enough space above the AAP assembly for the Cable Cubby lid to close completely. Secure the AAP shelf assembly into position with four Phillips head screws.

**NOTE** *If the AAP shelf assembly does not slide easily into the cubby, loosen the AAP mounting nuts. Retighten the AAP mounting nuts once the AAP shelf assembly is installed in position.*

### Adjusting the cable position (CC 200)

The Cable Cubby 200 has three cable stand-offs (figure 2-6) that allow you to set the height of the cables inside the enclosure. Adjust the cable height as follows:

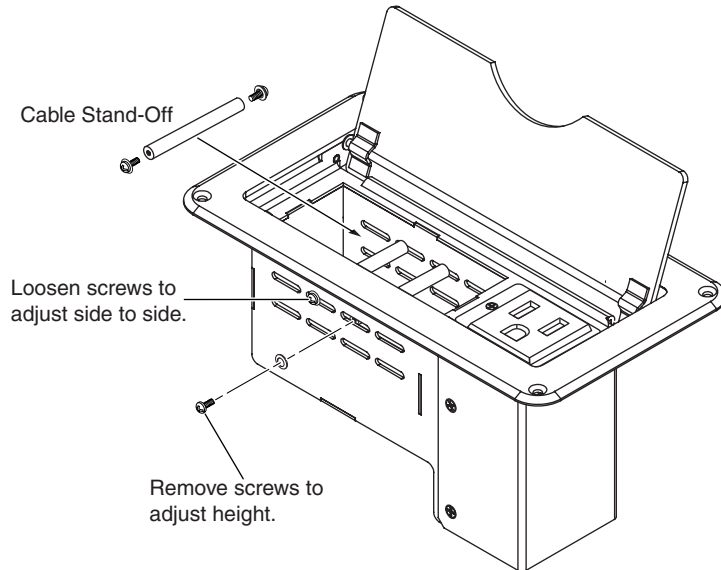

**Figure 2-6 — Cable Cubby 200 height adjustment**

1. Insert the stand-off into the Cable Cubby and align the stand-off with one set of horizontal slots in the side of the enclosure. Choose the adjustment height that best lifts the cable connectors off of the cable pass-through AAP and yet still allows the lid to be closed.
2. Loosely install the Phillips head screws and washers as shown in figure 2-6.

3. Install a second stand-off, in accordance with steps 1 and 2.
4. Slide the stand-offs back and forth in the horizontal slots to position them so that the cables easily rise and lower but do not fall below the stand-offs.
5. Tighten the Phillips head screws to lock the stand-offs into position.
6. Install and position the third stand-off, in accordance with steps 1 and 2 and 4 and 5 to secure the remaining cables.

### Mounting the Cable Cubby

**WARNING** *The flanged edges of the top of the surface enclosure are sharp. Exercise caution when the cubby is not installed in a table to prevent personal injury.*

**CAUTION** *The flanged edges of the top of the cubby are bevelled to an ultra-fine thickness of less than 0.04 (4/100)" (approximately 1 mm). These edges are soft and can be easily nicked or bent. Exercise caution when handling and mounting the enclosure. Mishandling can damage the appearance of the enclosure.*

1. **Cable Cubby 300, 600, and 800** — If screw clamps are installed, remove them from both sides of the enclosure (figure 2-7 on page 2-12).

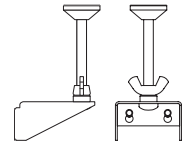

**NOTE** *Figure 2-7 shows the installation of a Cable Cubby 300C. Cable Cubby 300S, 600, and 800 installations are similar.*

2. Remove the plastic strips that protect the corners of the enclosure and the plastic film on the finished surfaces. If a sticky residue remains, remove it with an appropriate metal cleaning product.

**CAUTION** *Do not use isopropyl alcohol or other solvents to clean the Cable Cubby. Strong solvents will ruin some finishes.*

## Installation, cont'd

- Carefully lower the Cable Cubby into the hole to test the fit. If necessary, remove the enclosure and use a file or rasp to enlarge or smooth the edges of the opening (figure 2-7).

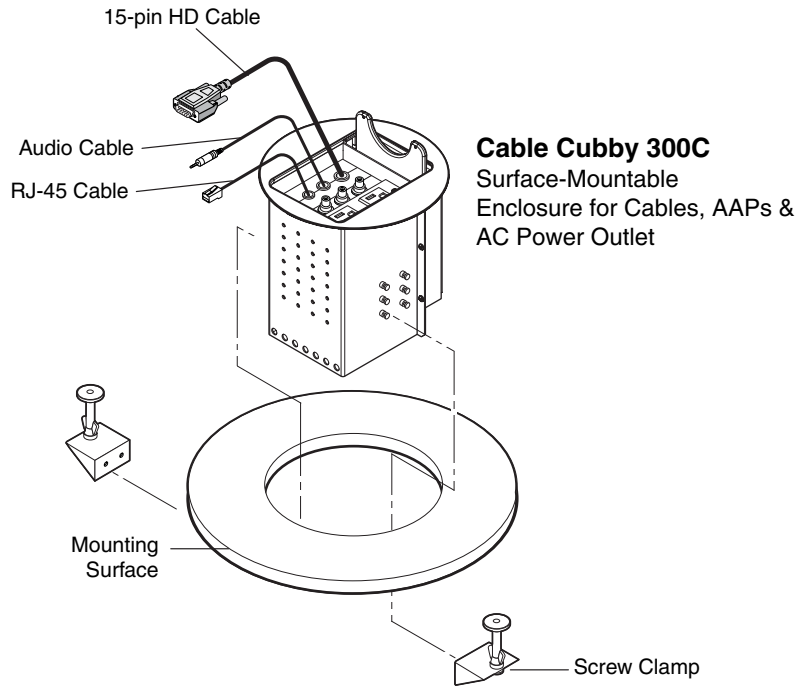

**Figure 2-7 — Cable Cubby 300C, installation view**

- Cable Cubby 300, 600, and 800** — From the underside of the table, reinstall the screw clamps on the enclosure at a height at which the clamp will reach the underside of the tabletop.

**CAUTION** Do not overtighten the Phillips head screws on the screw clamps. Overtightening can bend the horizontal flange of the screw clamp.

- Cable Cubby 300, 600, and 800** — Snugly tighten the Phillips head screws on the screw clamps to secure the enclosure to the surface.
- Cable Cubby 300, 600, and 800** — Tighten the locking thumbscrews on the screw clamps to lock the clamp in position.
- Cable Cubby 200** — Drill 1/8" (3 mm) pilot holes 1/2" (12 mm) deep into the table in the mounting holes at each of the four corners of the cubby.

- Cable Cubby 200** — Use the four included 6-32 x 1/2" screws to fasten the Cable Cubby 200 to the table (figure 2-8).

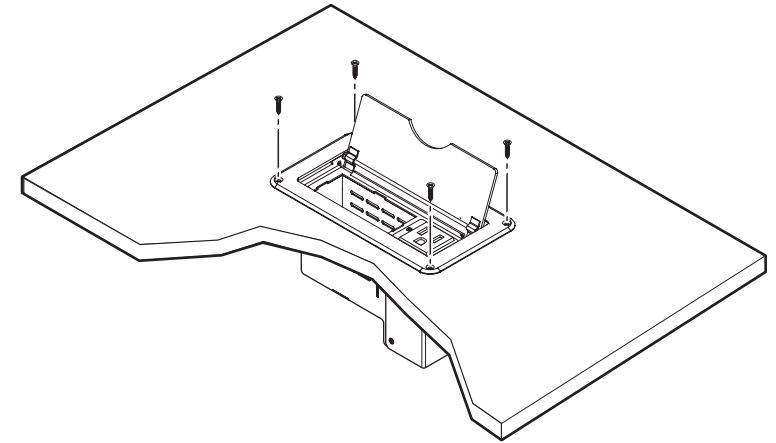

**Figure 2-8 — Cable Cubby, installation view**



# 3

## **Chapter 3**

### **Maintenance and Modifications**

Removing and Replacing the Cable Cubby

Replacing Cables or an AAP

Adding an Additional Power Module (CC 600, CC 800)

## Maintenance and Modifications

The Cable Cubby can be modified in the future to change cables, to replace an AAP, or to add a second power module. These modification may require removing the cubby from the table.

### Removing and Replacing the Cable Cubby

You may need to remove the cubby from the table in which it is mounted to replace cables or AAPs, to adjust the height of the AAP assemblies, or to install a second power module. Figure 3-1 shows removal of the Cable Cubby 300, 600, or 800 from the table and removal of the AAP shelf assembly and power module.

**NOTE** *The Cable Cubby 200 is screwed to the top surface of the table. Its shelves are fixed in position and not removable.*

Remove and replace the Cable Cubby for maintenance as follows:

**WARNING** *Ensure that AC power is disconnected before servicing the Cable Cubby.*

1. **Cable Cubby 300, 600, and 800** — Loosen the locking thumbscrews on the screw clamps to unlock the clamp (figure 3-1).
2. **Cable Cubby 300, 600, and 800** — Loosen the screw clamps.
3. **Cable Cubby 300, 600, and 800** — Remove the screw clamps on both sides of the enclosure.

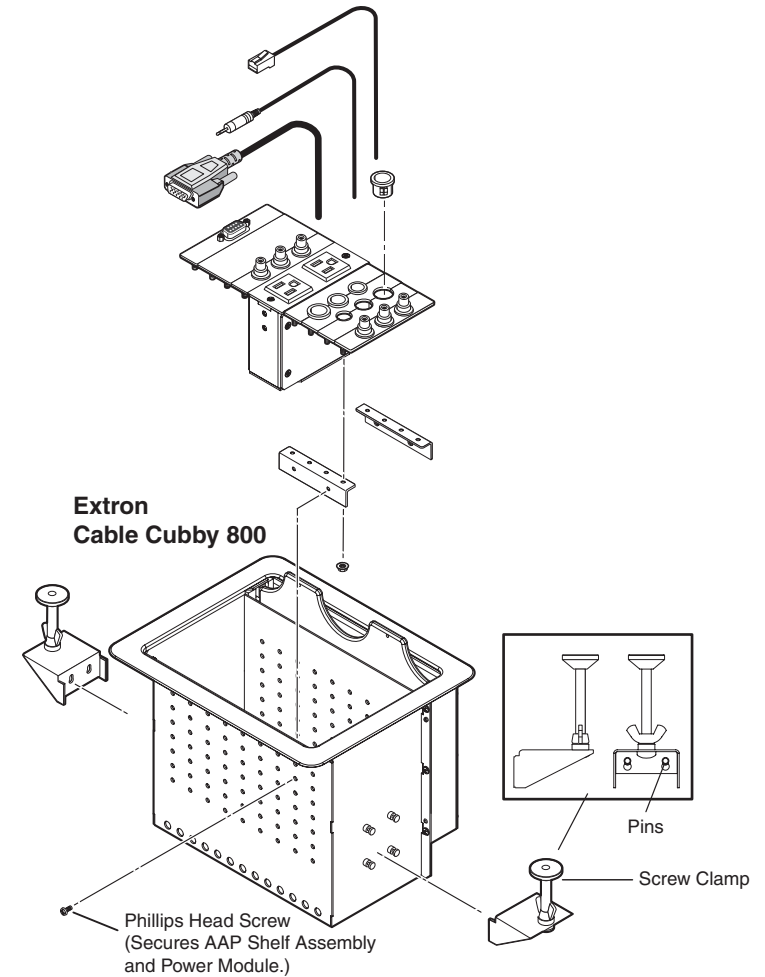
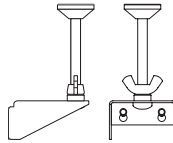

**Figure 3-1 — Removing the cubby and its shelves**

4. **Cable Cubby 200** — Remove the screws at the four corners that secure the cubby to the table (figure 3-2).

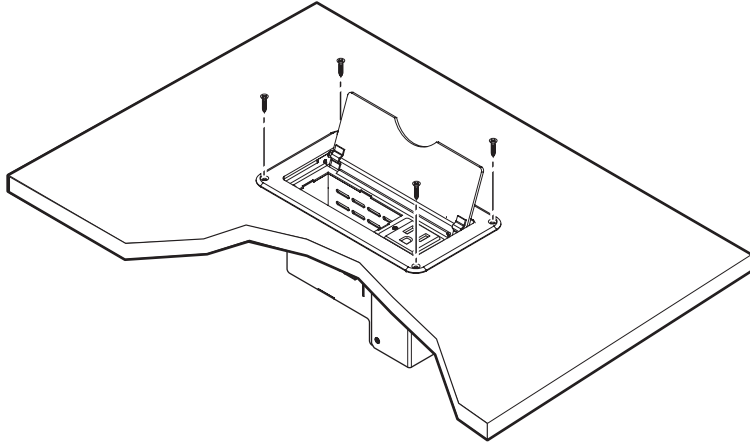

**Figure 3-2 — Removing the Cable Cubby 200**

5. Lift the enclosure from the table.

**WARNING** *The flanged edges of the top of the surface enclosure are sharp. Exercise caution when the cubby is not installed in a table to prevent personal injury.*

**CAUTION** *The flanged edges of the top of the cubby are bevelled to an ultra-fine thickness of less than 0.04 (4/100)" (approximately 1 mm). These edges are soft and can be easily nicked or bent. Exercise caution when handling and mounting the enclosure. Mishandling can damage the appearance of the enclosure.*

6. Remove the AAP shelf assembly(s) or power module by removing the four Phillips head screws on the front and rear of the Cable Cubby and gently pushing the assembly out through the bottom of the cubby.
7. Perform the desired maintenance procedure.
8. Carefully lower the Cable Cubby into the hole in the table.
9. **Cable Cubby 300, 600, and 800** — From the underside of the table, reinstall the screw clamps on the enclosure at a height at which the clamp will reach the underside of the tabletop.

**CAUTION** *Do not overtighten the Phillips head screws on the screw clamps. Overtightening can bend the horizontal flange of the screw clamp*

10. **Cable Cubby 300, 600, and 800** — Snugly tighten the Phillips head screws on the screw clamps to secure the enclosure to the surface.
11. **Cable Cubby 300, 600, and 800** — Tighten the locking thumbscrews on the screw clamps to lock the clamp in position.
12. **Cable Cubby 200** — Fasten the Cable Cubby 200 to the table with the four 6-32 x 1/2" screws removed in step 4 (figure 3-2).

### Replacing Cables or an AAP

Before you change the cables inside the cubby or replace one or more AAPs on Cable Cubby 300, 600, and 800 models, you must remove the AAP shelf assembly from the Cable Cubby. Use the following guidelines as applicable:

1. **Cable Cubby 300, 600, and 800** — If the Phillips head screws on the front and rear of the cubby are blocked by the table, remove the cubby from the table. See *Removing and Replacing the Cable Cubby*, steps 1 through 4, earlier in this chapter.
2. **Cable Cubby 300, 600, and 800** — Remove the AAP shelf assembly(s) by removing the four Phillips head screws on the front and rear of the Cable Cubby and gently pushing the assembly out through the bottom of the cubby.
3. Change the cables and/or AAPs the same way you installed them. See *Installing the Cables and AAPs* in chapter 2, *Installation*.
4. **Cable Cubby 300, 600, and 800** — If you removed the cubby from the table, reinstall the surface mount enclosure. See *Removing and Replacing the Cubby*, steps 8 through 11, earlier in this chapter.



### Adding an Additional Power Module (CC 600 and CC 800)

Each additional power module occupies two (USA/domestic models) or three (international models) of the cubby's AAP spaces, reducing the amount of AAP space available in the cubby for cable pass through (split) or passive AAPs. Use the following guidelines as applicable:

- 1 Replacement two-space, three-space, and four-space shelf brackets and cable pass-through (split) AAPs are available from Extron, and may be required to maximize the remaining available space if you add a power module.
  - **Cable Cubby 200 models** — Adding a second power module is **not** possible.
  - **Cable Cubby 300 models** — Adding a second power module is **not** recommended. Depending on the model, with a second power module, there is room left for either only a single one-space AAP or no AAP space left at all.
  - **Cable Cubby 600 and 800 international models** — In general, you probably **do not** need replacement shelf brackets when you add an international module to an international Cable Cubby, because the power module replaces a three-space shelf that is standard in all international cubbies.

Figure 3-3 shows typical configurations before and after you add a second power module to an international Cable Cubby 600.

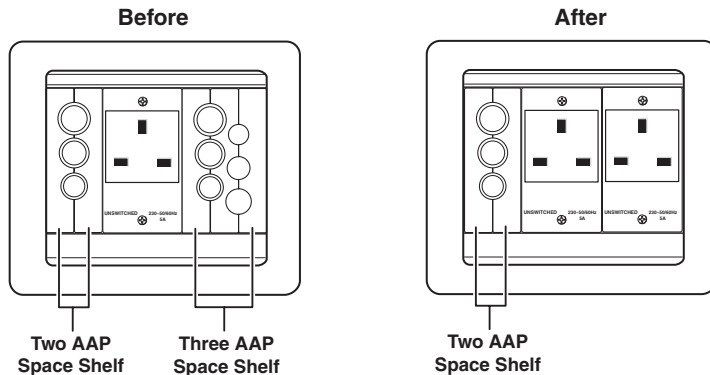

**Figure 3-3 — International Cable Cubby 600 with second power module**

Figure 3-4 shows typical configurations before and after you add a second power module to an international Cable Cubby 800.

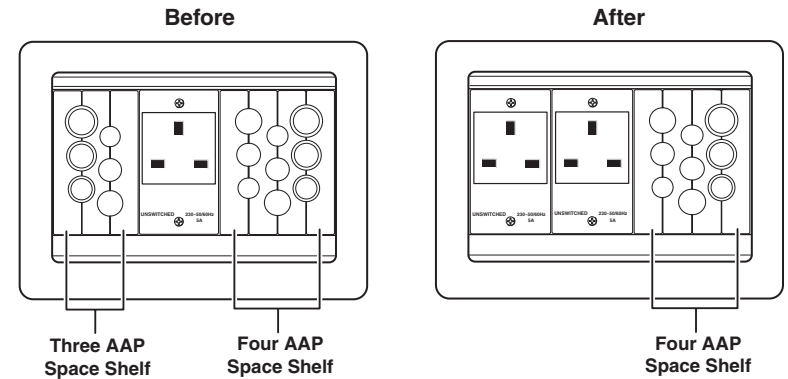
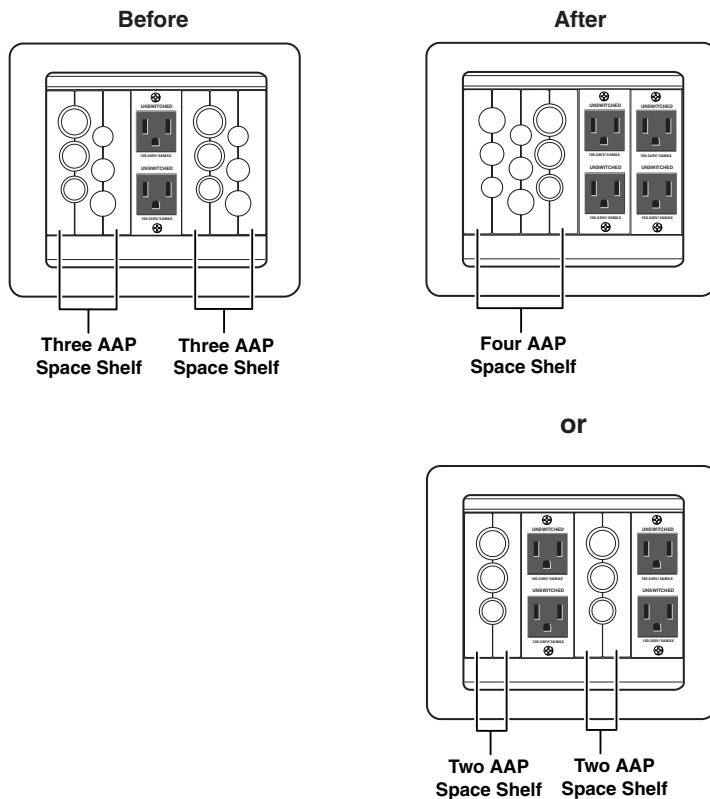

**Figure 3-4 — International Cable Cubby 800 with second power module**

## Maintenance and Modifications, cont'd

- **Cable Cubby 600 and 800 US/Domestic models** — You probably **do** need replacement shelf brackets when you add a US/Domestic power module to a US/Domestic Cable Cubby, because the power module takes up two spaces in a cubby that, in its standard configuration, is equipped with three-space (Cable Cubby 600) or four-space (Cable Cubby 800) shelves.

Figure 3-5 shows typical configurations before and after you add a second US/Domestic power module to a US/domestic Cable Cubby 600 and suggests rack shelf configurations to replace the shelf space removed.



**Figure 3-5 — Cable Cubby 600 with second power module**

Figure 3-6 shows typical configurations before and after you add a second US/Domestic power module to a US/domestic Cable Cubby 800 and suggests rack shelf configurations to replace the lost shelf space.

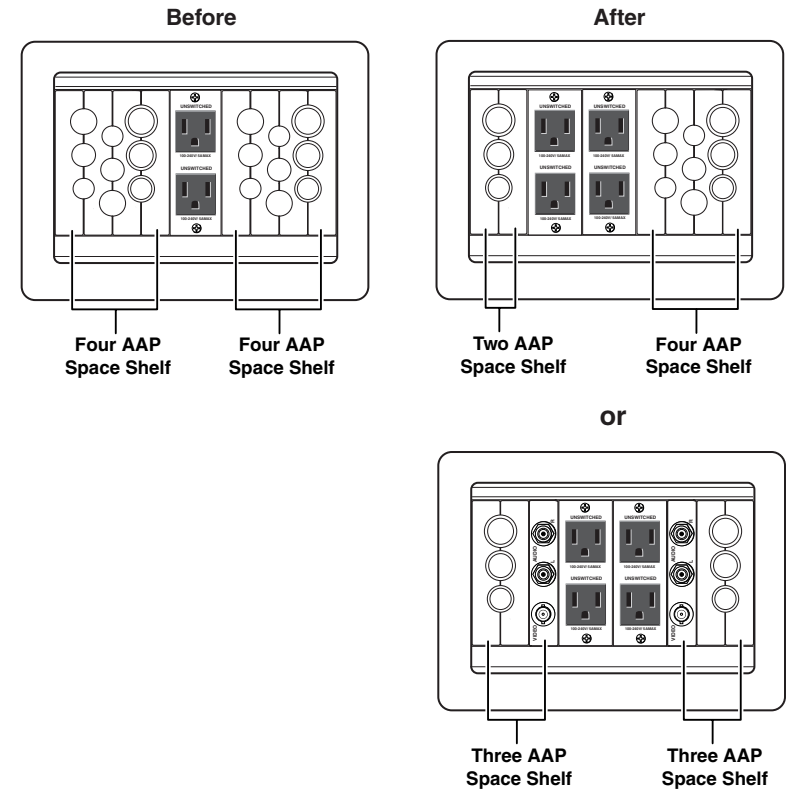

**Figure 3-6 — Cable Cubby 800 with second power module**

- 2 If the Phillips head screws on the front and rear of the cubby are blocked by the table, remove the cubby from the table. See *Removing and Replacing the Cable Cubby*, steps 1 through 4, earlier in this chapter.
- 3 Before you add an additional power module, you must make room for the Cable Cubby by eliminating two or three AAP spaces and the AAP shelf brackets that support them. Remove the Phillips head screws on the front and rear of the Cable Cubby and gently pushing the assembly(s) out through the bottom of the cubby.

- From the underside of the Cable Cubby, gently push the additional power module into the desired position at the desired elevation. Secure the power module into position with the included four Phillips head screws (figure 3-7).

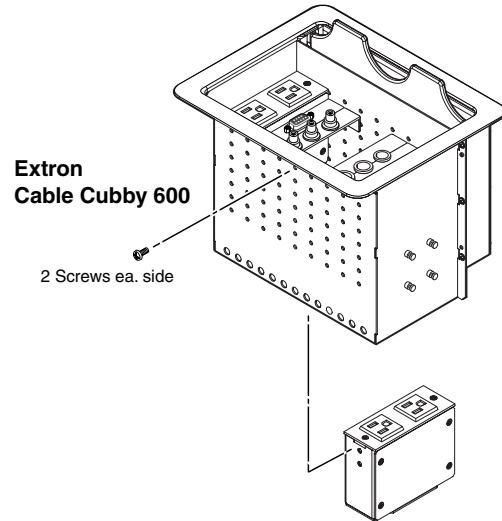

**Figure 3-7 — Installing the power module**

- If desired, assemble and install replacement AAP shelf assemblies. Remember that the cable pull function of the Cable Cubby requires at least two AAPs. See *Installing the Cables and AAPs* in chapter 2, *Installation*.
- If you removed the cubby from the table, reinstall the surface mount enclosure. See *Removing and Replacing the Cable Cubby*, steps 8 through 11, earlier in this chapter.



**Cable Cubby® Products**

# Appendix A

## Reference Information

Specifications

Cable Cubby Part Numbers

Included Parts

Replacement/Modification Part Numbers

Routing Template Part Numbers

Top Plate Dimensions

# Reference Information

## Specifications

### General

Rack mount ..... No, but furniture mountable  
 Enclosure type ..... Metal

### Enclosure dimensions

**CAUTION** Use the appropriate metal Extron routing template or refer to the surface cutout dimensions here before cutting a hole in the furniture or other surface. Pay special attention to the direction the unit will face; the unit's AAP and connector access side is underlined. Extron is not responsible for miscut mounting holes.

**NOTE** Architectural Adapter Plates (AAPs) are shown in the diagrams that follow and in photographs as examples only. AAPs are optional accessories for the Cable Cubby products. AAPs and cables must be ordered separately.

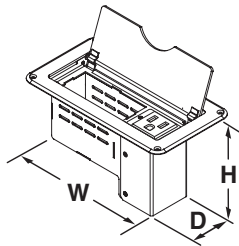

**Cable Cubby 200**

<b>Cable Cubby 200</b>	
Top plate (outer rim).....	8.000" W x 4.394" D (20.32 cm W x 11.16 cm D)
Surface cutout (inside rim) .....	7.185 ±0.0325" W x 3.155 ±0.0325" D (18.25 ±0.083 cm W x 8.01 ±0.083 cm D)
Box (under surface) .....	4.000" H x <u>7.120</u> " W (front/rear of unit) x 2.974" D (10.16 cm H x <u>18.08</u> cm W x 7.55 cm D)

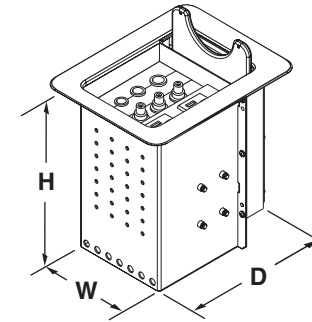

**Cable Cubby 300S**

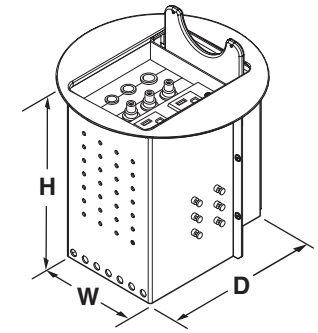

**Cable Cubby 300C**

<b>Cable Cubby 300S</b>	
Top plate (outer rim).....	5.130" W x 6.470" D (13.0 cm W x 16.4 cm D)
Surface cutout (inside rim) .....	<u>4.625</u> ±0.0325" W x 5.970 ±0.0325" D ( <u>11.75</u> ±0.083 cm W x 15.16 ±0.083 cm D)
Box (under surface) .....	6.410" H x <u>4.320</u> " W (front/rear of unit) x 4.750" D <b>without clamps</b> (16.28 cm H x <u>10.97</u> cm W x 12.07 cm D) <b>without clamps</b> 6.410" H x <u>6.57</u> " W x 4.750" D <b>with clamps</b> (16.28 cm H x <u>16.68</u> cm W x 12.07 cm D) <b>with clamps</b>
<b>Cable Cubby 300C</b>	
Top plate (outer rim) .....	6.500" (16.51 cm) diameter circle
Surface cutout (inside rim) .....	6.000 ±0.0325" (15.24 ±0.083 cm) diameter circle
Box (under surface) .....	6.410" H x <u>4.320</u> " W (front/rear of unit) x 4.750" D <b>without clamps</b> (16.28 cm H x <u>10.97</u> cm W x 12.07 cm D) <b>without clamps</b> 6.410" H x <u>6.57</u> " W x 4.750" D <b>with clamps</b> (16.28 cm H x <u>16.68</u> cm W x 12.07 cm D) <b>with clamps</b>

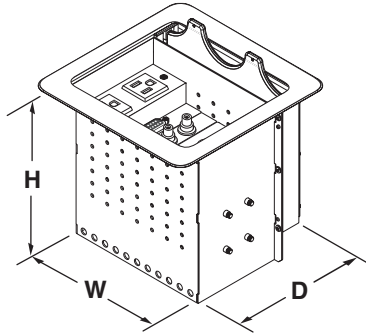

**Cable Cubby 600**

**Cable Cubby 600**

Top plate (outer rim) .....	<u>6.960</u> " W x 6.960" D ( <u>17.68</u> cm W x 17.68 cm D)
Surface cutout (inside rim) .....	<u>6.460</u> ±0.0325" W x 6.460 ±0.0325" D ( <u>16.41</u> ±0.083 cm W x 16.41 ±0.083 cm D)
Box (under surface) .....	6.410" H x <u>6.400</u> " W (front/rear of unit) x 4.750" D <b>without clamps</b> (16.28 cm H x <u>16.26</u> cm W x 12.07 cm D) <b>without clamps</b> 6.410" H x <u>8.67</u> " W x 4.750" D <b>with clamps</b> (16.28 cm H x <u>22.02</u> cm W x 12.07 cm D) <b>with clamps</b>

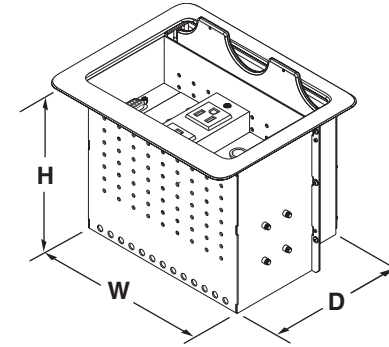

**Cable Cubby 800**

**Cable Cubby 800**

Top plate (outer rim) .....	<u>8.360</u> " W x 6.820" D ( <u>21.23</u> cm W x 17.32 cm D)
Surface cutout (inside rim) .....	<u>7.860</u> ±0.0325" W x 6.320 ±0.0325" D ( <u>19.96</u> ±0.083 cm W x 16.05 ±0.083 cm D)
Box (under surface) .....	6.410" H x <u>7.800</u> " W (front/rear of unit) x 4.750" D <b>without clamps</b> (16.28 cm H x <u>19.81</u> cm W x 12.07 cm D) <b>without clamps</b> 6.410" H x <u>10.07</u> " W x 4.750" D <b>with clamps</b> (16.28 cm H x <u>25.58</u> cm W x 12.07 cm D) <b>with clamps</b>

Cable AAP cable hole diameters

Large cable hole.....	0.63" (1.60 cm)
Large grommet .....	0.45" (1.14 cm)
Medium cable hole.....	0.56" (1.42 cm)
Medium grommet .....	0.39" (0.99 cm)
Small cable hole.....	0.50" (1.27 cm)
Small grommet .....	0.31" (0.79 cm)

Product weight

Cable Cubby 200 .....	2.5 lbs (1.1 kg)
Cable Cubby 300S/300C ..	5.0 lbs (2.3 kg)
Cable Cubby 600.....	9.0 lbs (4.1 kg)
Cable Cubby 800.....	13.0 lbs (5.9 kg)

## Packaging for Shipment, cont'd

### Shipping weight

Cable Cubby 200.....	4 lbs (2 kg)
Cable Cubby 300S .....	8 lbs (4 kg)
Cable Cubby 300C.....	8 lbs (4 kg)
Cable Cubby 600.....	12 lbs (6 kg)
Cable Cubby 800.....	15 lbs (7 kg)

Vibration ..... ISTA 1A in carton  
(International Safe Transit Association)

Listings, certifications..... UL, CUL, CSA C/US

Compliances..... CE

Warranty ..... 3 years parts and labor

**NOTE** Specifications are subject to change without notice.

## Cable Cubby Part Numbers

Cable Cubby 200	Part number
Cable Cubby 200 US/domestic (powder coat finish)	60-716-01
Cable Cubby 200S international (powder coat finish)	60-717- <i>nn</i>

Cable Cubby 300S	Part number
Cable Cubby 300S US/domestic (black anodized finish)	60-526-01
Cable Cubby 300S international	60-712- <i>nn</i>

Cable Cubby 300C	Part number
Cable Cubby 300C/domestic (black anodized finish)	60-527-01
Cable Cubby 300C international	60-713- <i>nn</i>

Cable Cubby 600	Part number
Cable Cubby 600 US/domestic (black anodized finish)	60-525-01
Cable Cubby 600 international	60-714- <i>nn</i>

Cable Cubby 800	Part number
Cable Cubby 800 US/domestic (black anodized finish)	60-524-01
Cable Cubby 800 international	60-715- <i>nn</i>

**NOTE** For the international versions, the *nn* in the part number identifies the AC power connector and finish (black anodized, brushed aluminum, polished aluminum, and brushed brass). Specify the desired power connector and finish when ordering.

**NOTE** All Cable Cubby 200 models are available in a powder coat finish only.

**NOTE** The USA versions of the Cable Cubby 300, 600, and 800 are also available in brushed aluminum, polished aluminum, and brushed brass finishes. Visit the Extron web site, [www.extron.com](http://www.extron.com) for more part numbers.

Included Parts

The Cable Cubby includes the Cable Cubby® Products manual and a selection of shelf brackets, cable pass through AAPs, grommets, and hole plugs that vary depending on the Cable Cubby model. See the table below for included parts:

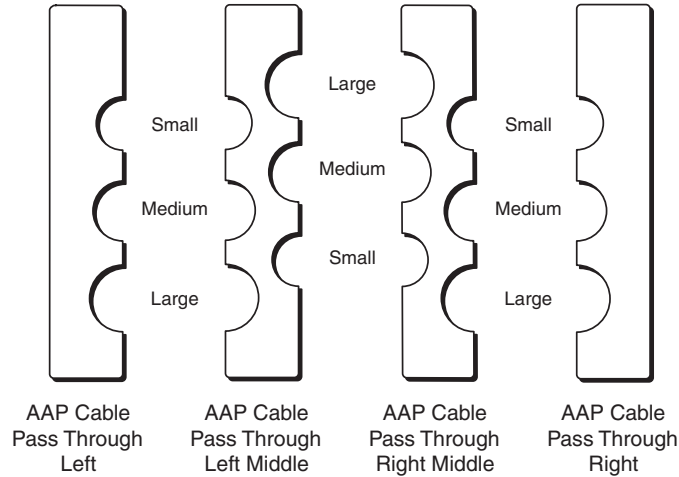

Model	AAP Shelf brackets			Pass through AAPs*				Grommets†			Plugs†		
	2 Pos.	3. Pos	4. Pos	L	L-M	R-M	R	L	M	S	L	M	S
CC 200 US	0*	0	0	1	0	0	1	1	1	1	1	1	1
CC 200 Int.	0*	0	0	1	0	0	1	1	1	1	1	1	1
CC 300* US	0	2	0	2	1	0	0	2	2	2	2	2	2
CC 300* Int.	2	0	0	1	0	0	1	1	1	1	1	1	1
CC 600 US	0	4	0	1	2	2	1	5	5	5	5	5	5
CC 600 Int.	2	2	0	2	2	1	0	4	4	4	4	4	4
CC 800 US	0	0	4	1	3	3	1	7	7	7	7	7	7
CC 800 Int.	0	2	2	2	3	2	0	6	6	6	6	6	6

- \* L = left, L-M = left-middle, R-M = right middle, R = right
- † L = large, M = medium, S = small
- ☆ Fixed two position shelf incorporated into the enclosure
- ❖ CC 300 S and CC 300 C have the same AAP configuration

Replacement/Modification Part Numbers

Power modules (CC 300, 600, 800)	Part number
Cable Cubby AC power module–USA	70-261-01
Cable Cubby AC power module–Swiss	70-262-01
Cable Cubby AC power module–Israel	70-388-01
Cable Cubby AC power module–Europe	70-264-01
Cable Cubby AC power module–Australia	70-265-01
Cable Cubby AC power module–UK	70-266-01
Cable Cubby AC power module–France	70-389-01
Cable Cubby AC power module–India	70-390-01

Cable pass-through AAPs	Part number
<b>NOTE</b> Each AAP cable pass-through kit listed below includes three grommets; one large, one medium, and one small.	
AAP cable pass through (right) (figure A-1)	70-267-01
AAP cable pass through (right-middle) (figure A-1)	70-268-01
AAP cable pass through (left-middle) (figure A-1)	70-269-01
AAP cable pass through (left) (figure A-1)	70-270-01

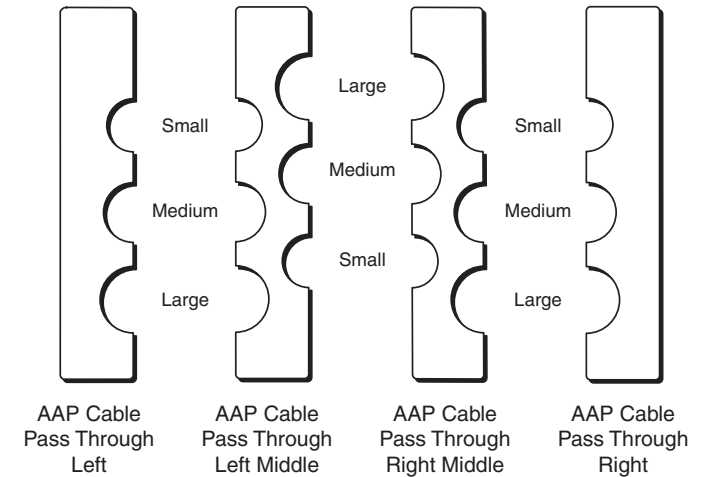
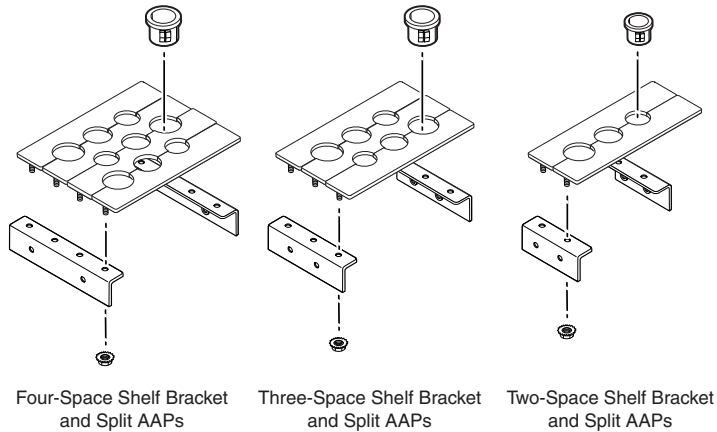

Figure A-1 — Cable pass through AAPs

## Packaging for Shipment, cont'd

AAP shelf brackets (CC 300, 600, 800)	Part number
Four-space AAP Cable Cubby bracket (set of 2) (figure A-2)	70-273-01
Three-space AAP Cable Cubby bracket (set of 2) (figure A-2)	70-272-01
Two-space AAP Cable Cubby bracket (set of 2) (figure A-2)	70-271-01
Single-space AAP Cable Cubby bracket (set of 2) (figure A-2)	70-392-01



**Figure A-2 — Shelf brackets**

Grommet and plug kit	Part number
<b>NOTE</b> The kit listed below includes three grommets; one large, one medium, and one small.	
Grommet and hole plug kit	70-387-01

## Routing Template Part Numbers

The following reusable sheet metal routing templates are recommended for installation and are available **at no charge**.

Template	Part number
Cable Cubby 200 routing template	70-384-01
Cable Cubby 300S/300C routing template	70-237-01
Cable Cubby 600 routing template	70-239-01
Cable Cubby 800 routing template	70-240-01

## Top Plate Dimensions

There are two **preferred** and **recommended** methods for cutting the table: either use the appropriate metal routing template (figure A-3 and chapter 2, *Installation*) and a router or use a hole saw (Cable Cubby 300C only). The templates (see *Routing Template Part Numbers*, for part numbers) are available at no cost.

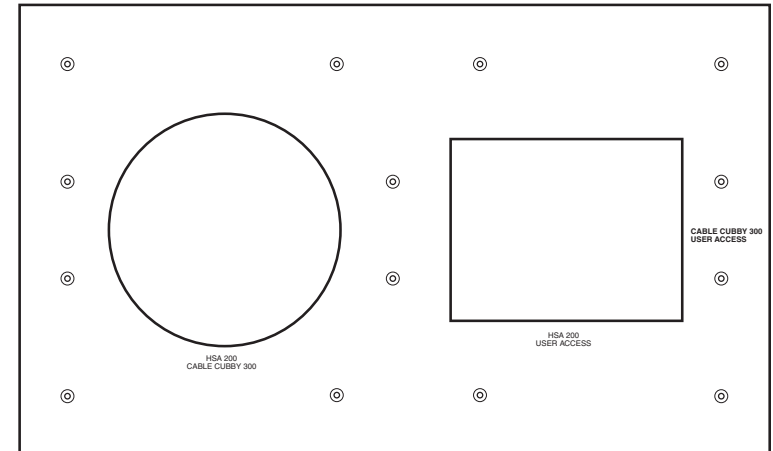

**Figure A-3 — CC 300S/300C metal routing template**

If you choose not to use Extron's metal routing templates, the cut-out templates (figure A-4, figure A-5, figure A-6, figure A-7, and figure A-8) will help you properly prepare the mounting surface. The cutout templates are **not to scale** and are **for reference only**. The surface cut-out area dimensions for the template are **marked in bold type**.

For full size paper templates, visit the Extron Web site (<http://www.extron.com>) or call the Extron S<sup>3</sup> Sales & Technical Support Hotline.



Cut-Out Template for Extron's  
**Cable Cubby 200**

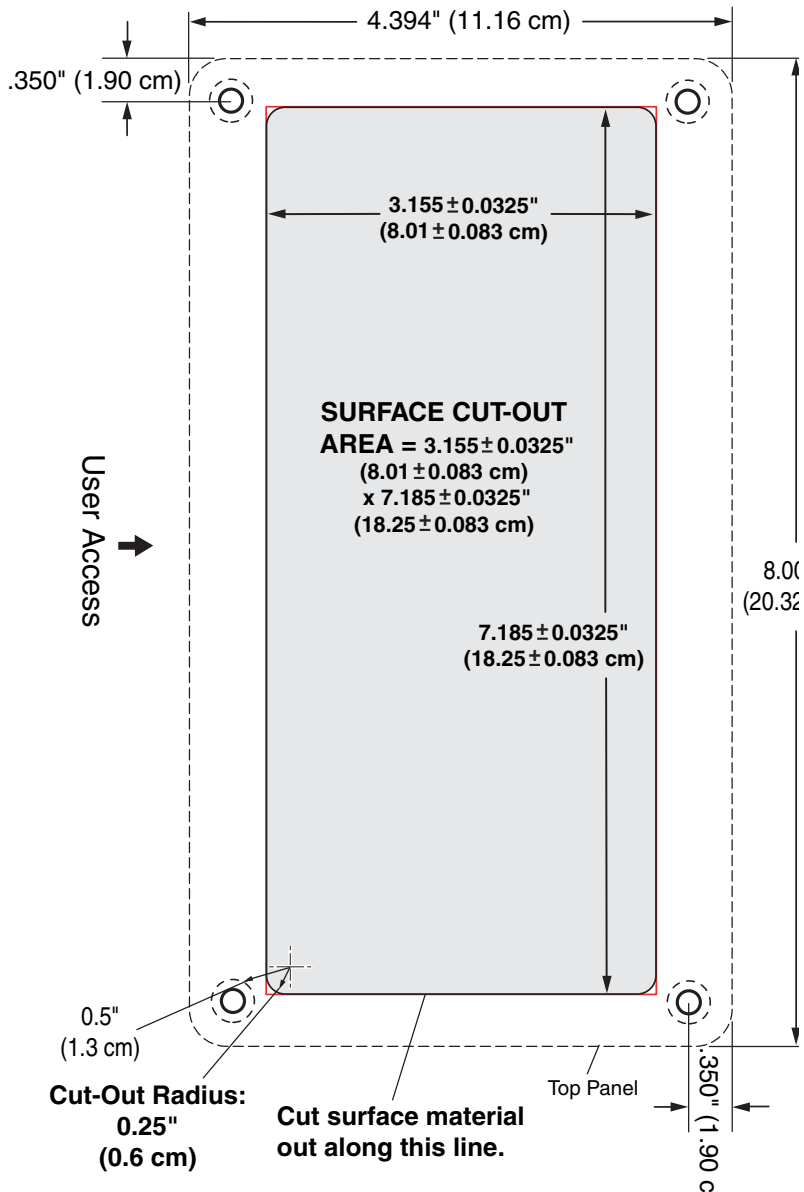

Figure A-4 — Cable Cubby 200 cut-out template

Cut-Out Template for Extron's  
**Cable Cubby 300S**

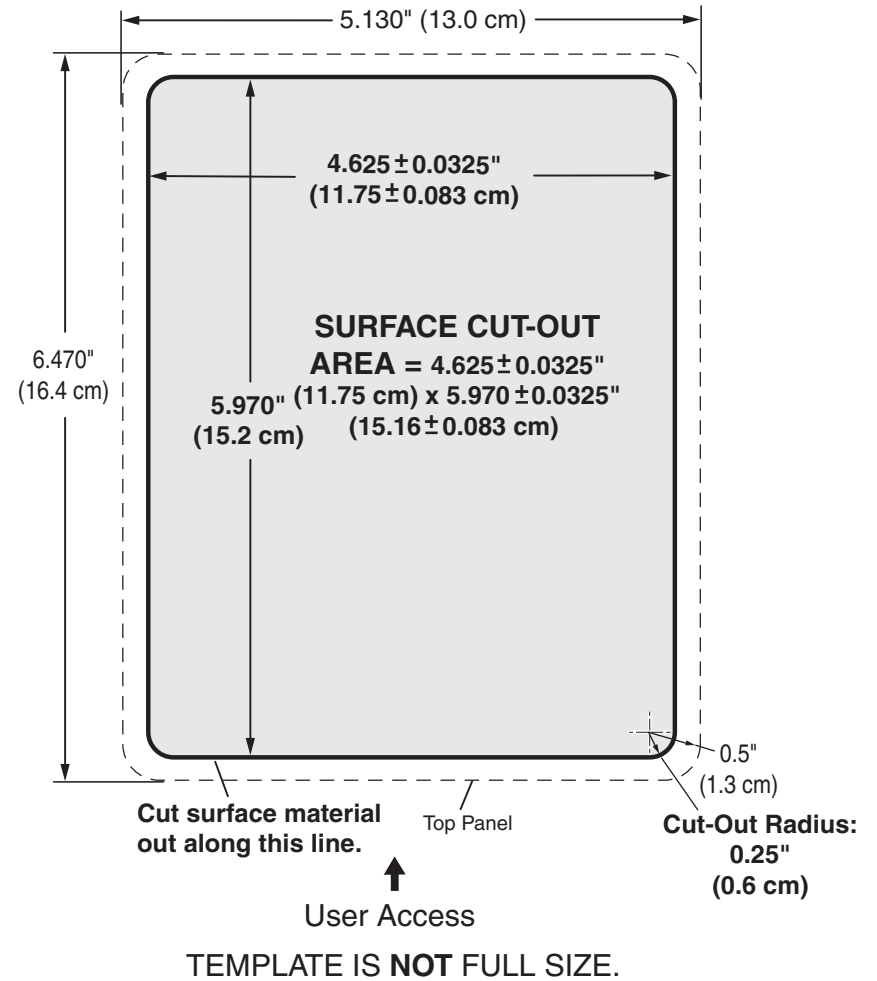
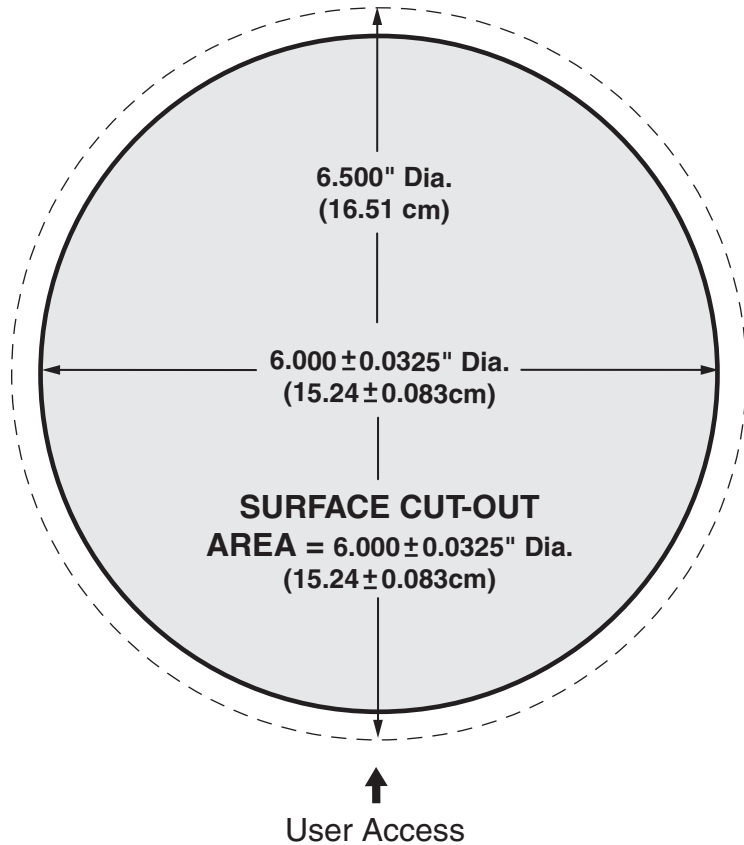

Figure A-5 — Cable Cubby 300S cut-out template

Cut-Out Template for Extron's  
**Cable Cubby 300C**



TEMPLATE IS **NOT** FULL SIZE.

**Figure A-6 — Cable Cubby 300C cut-out template**

Cut-Out Template for Extron's  
**Cable Cubby 600**

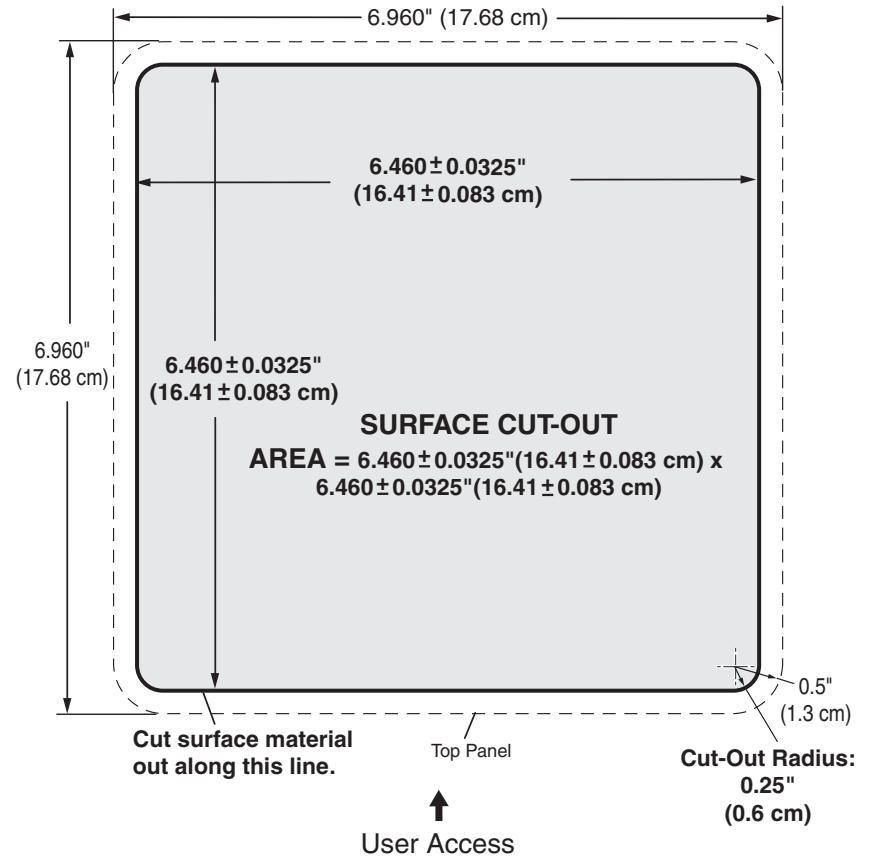

TEMPLATE IS **NOT** FULL SIZE.

**Figure A-7 — Cable Cubby 600 cut-out template**



Cut-Out Template for Extron's  
**Cable Cubby 800**

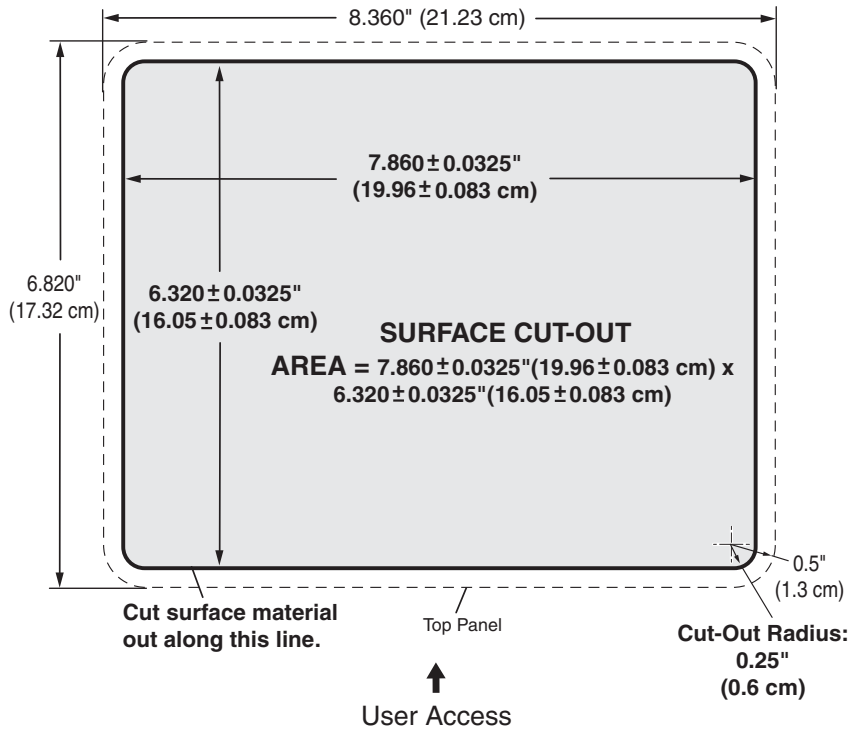

TEMPLATE IS NOT FULL SIZE.

**Figure A-8 — Cable Cubby 800 cut-out template**

# Appendix B

## Packaging for Shipment

## Packaging for Shipment

The Cable Cubby's ultra-fine machined surfaces and moving parts make them vulnerable to damage caused by mishandling during shipment if they are improperly packaged. If, for any reason, you need to return a Cable Cubby to Extron, first contact Extron to obtain a return kit. The return kit, which reduces the chances of damage during shipment, includes a sturdy shipping carton and foam that can be fitted to each Cable Cubby model (figure B-1).



**Figure B-1 — Cable Cubby return kit**

Package a Cable Cubby for shipment as follows:

1. Contact the Extron S<sup>3</sup> Sales & Technical Support Hotline to obtain a return kit. Extron will send the return kit to the location you specify.

**WARNING** *The flanged edges of the top of the surface enclosure are sharp when the Cable Cubby is removed from the table. Exercise caution when handling to prevent personal injury.*

**CAUTION** *The flanged edges of the top of the surface enclosure are bevelled to an ultra-fine thickness of less than 0.04 (4/100)'' (approximately 1 mm). These edges are soft and can be easily nicked or bent. Exercise caution when handling and mounting the enclosure. Mishandling can damage the appearance of the enclosure.*

2. Disconnect and retain all cables, remove and retain the AAP shelf assembly(s) (CC 300, 600, 800) and remove the Cable Cubby from the table or desk. See *Removing and Replacing the Cubby*, steps 1 through 4, in chapter 3, *Maintenance and Modifications*.

**NOTE** *For Cable Cubby 300, 600, and 800 models, retain the screw clamps.*

3. Install the plastic strips that protect the flanged edges of the top of the surface enclosure (figure B-2).



**Figure B-2 — Installing protective strips**

**NOTE** *For Cable Cubby 200 models proceed to step 13. For Cable Cubby 300, 600, and 800 models, continue to step 4, below.*

4. Remove and retain the top foam pad from the carton.
5. **CC 300, 600, 800 only** — Remove and discard the center foam section of the cushion in the carton (figure B-3). **If you are returning a Cable Cubby 300 model, this is the correct fit. Proceed to step 8.**

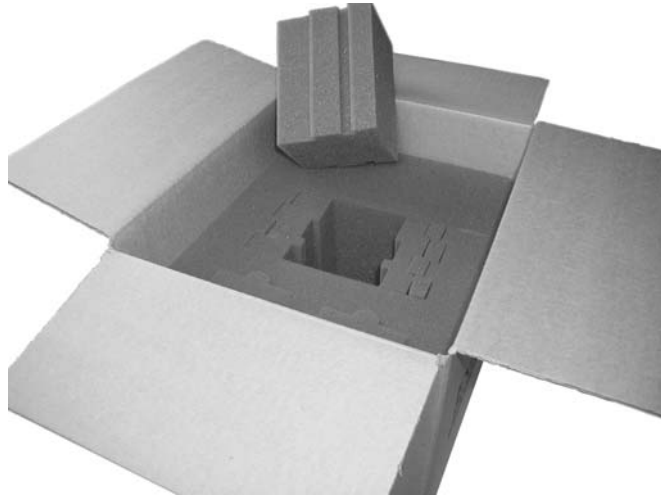

**Figure B-3 — Removing center foam**

6. **CC 600, 800 only** — Remove and discard the inner side foam sections of the cushion in the carton (figure B-4). **If you are returning a Cable Cubby 600 model, this is the correct fit.** Proceed to step 8.

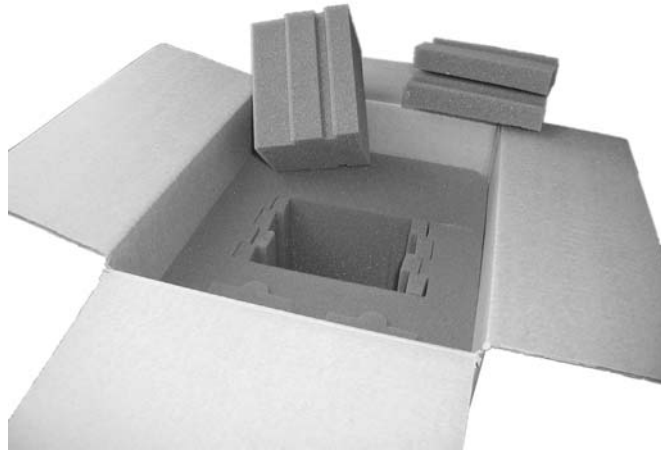

**Figure B-4 — Removing inner side foams**

7. **CC 800 only** — Remove and discard the outer side foam sections of the cushion in the carton (figure B-5). **This is the correct fit for a Cable Cubby 800 model.** Proceed to step 8.

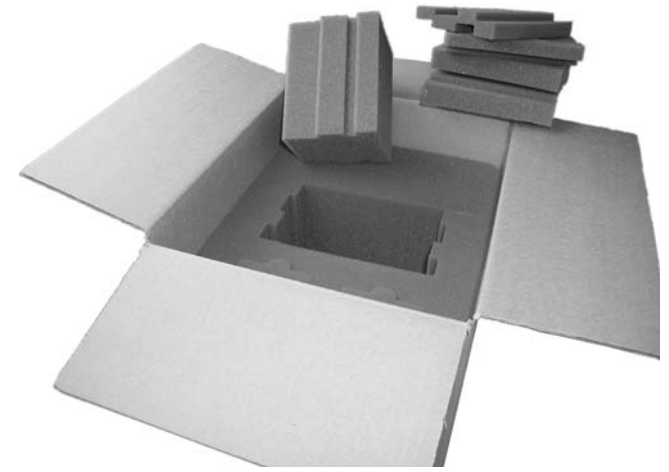

**Figure B-5 — Removing outer side foams**

8. **If you will not install a replacement Cable Cubby in this location,** remove and retain one of the small foam sections to the front or rear of the cubby opening in the cushion in the carton (figure B-6).

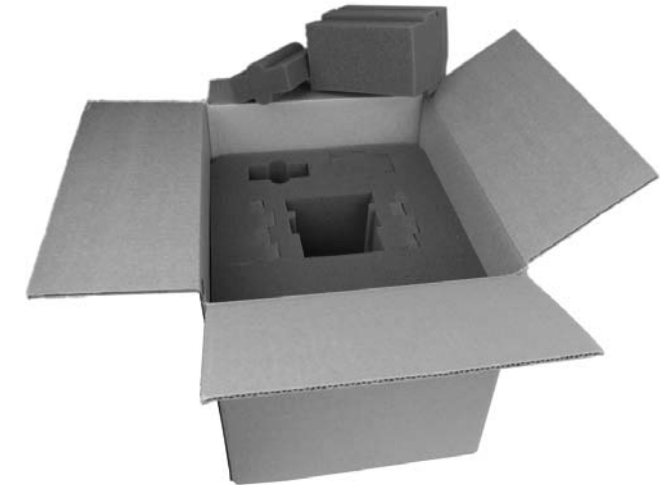

**Figure B-6 — Removing screw clamp area foam**

9. **CC 300, 600, 800 only** — Place the two screw clamps from step 2 into the screw clamp opening in the foam cushion in the carton.

## Packaging for Shipment, cont'd

---

10. **CC 300, 600, 800 only** — Stuff the foam section removed in step 8 into the screw clamp opening in the foam cushion in the carton.
11. **CC 300, 600, 800 only** — Lower the Cable Cubby, with the top closed, into the foam cushion in the shipping carton (figure B-7).

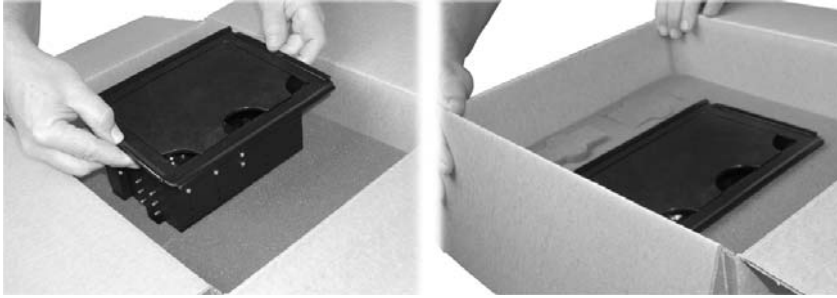

**Figure B-7 — Placing the cubby in the carton**

12. **CC 200 only** — Insert the Cable Cubby 200 into the foam shell (figure B-8). Firmly push the Cable Cubby into the foam shell to completely suspend the Cable Cubby.



**Figure B-8 — Installing the foam shell**

13. **CC 200 only** — Lower the Cable Cubby and foam into the shipping carton.
14. Place the top foam pad, removed in step 4, on top of the Cable Cubby.
15. Close the shipping carton and seal it with high quality shipping tape.
16. Ship the Cable Cubby to Extron using a reputable shipping company.



## **Packaging for Shipment**

---



# Precautions

## Safety Instructions • English



This symbol is intended to alert the user of important operating and maintenance (servicing) instructions in the literature provided with the equipment.



This symbol is intended to alert the user of the presence of uninsulated dangerous voltage within the product's enclosure that may present a risk of electric shock.

## Caution

**Read Instructions** • Read and understand all safety and operating instructions before using the equipment.

**Retain Instructions** • The safety instructions should be kept for future reference.

**Follow Warnings** • Follow all warnings and instructions marked on the equipment or in the user information.

**Avoid Attachments** • Do not use tools or attachments that are not recommended by the equipment manufacturer because they may be hazardous.

## Consignes de Sécurité • Français



Ce symbole sert à avertir l'utilisateur que la documentation fournie avec le matériel contient des instructions importantes concernant l'exploitation et la maintenance (réparation).



Ce symbole sert à avertir l'utilisateur de la présence dans le boîtier de l'appareil de tensions dangereuses non isolées posant des risques d'électrocution.

## Attention

**Lire les instructions** • Prendre connaissance de toutes les consignes de sécurité et d'exploitation avant d'utiliser le matériel.

**Conservier les instructions** • Ranger les consignes de sécurité afin de pouvoir les consulter à l'avenir.

**Respecter les avertissements** • Observer tous les avertissements et consignes marqués sur le matériel ou présents dans la documentation utilisateur.

**Eviter les pièces de fixation** • Ne pas utiliser de pièces de fixation ni d'outils non recommandés par le fabricant du matériel car cela risquerait de poser certains dangers.

## Sicherheitsanleitungen • Deutsch



Dieses Symbol soll dem Benutzer in der im Lieferumfang enthaltenen Dokumentation besonders wichtige Hinweise zur Bedienung und Wartung (Instandhaltung) geben.



Dieses Symbol soll den Benutzer darauf aufmerksam machen, daß im Inneren des Gehäuses dieses Produktes gefährliche Spannungen, die nicht isoliert sind und die einen elektrischen Schock verursachen können, herrschen.

## Achtung

**Lesen der Anleitungen** • Bevor Sie das Gerät zum ersten Mal verwenden, sollten Sie alle Sicherheits- und Bedienungsanleitungen genau durchlesen und verstehen.

**Aufbewahren der Anleitungen** • Die Hinweise zur elektrischen Sicherheit des Produktes sollten Sie aufbewahren, damit Sie im Bedarfsfall darauf zurückgreifen können.

**Befolgen der Warnhinweise** • Befolgen Sie alle Warnhinweise und Anleitungen auf dem Gerät oder in der Benutzerdokumentation.

**Keine Zusatzgeräte** • Verwenden Sie keine Werkzeuge oder Zusatzgeräte, die nicht ausdrücklich vom Hersteller empfohlen wurden, da diese eine Gefahrenquelle darstellen können.

## Instrucciones de seguridad • Español



Este símbolo se utiliza para advertir al usuario sobre instrucciones importantes de operación y mantenimiento (o cambio de partes) que se desean destacar en el contenido de la documentación suministrada con los equipos.



Este símbolo se utiliza para advertir al usuario sobre la presencia de elementos con voltaje peligroso sin protección aislante, que puedan encontrarse dentro de la caja o alojamiento del producto, y que puedan representar riesgo de electrocución.

## Precaución

**Leer las instrucciones** • Leer y analizar todas las instrucciones de operación y seguridad, antes de usar el equipo.

**Conservar las instrucciones** • Conservar las instrucciones de seguridad para futura consulta.

**Obedecer las advertencias** • Todas las advertencias e instrucciones marcadas en el equipo o en la documentación del usuario, deben ser obedecidas.

**Evitar el uso de accesorios** • No usar herramientas o accesorios que no sean específicamente recomendados por el fabricante, ya que podrían implicar riesgos.

## Warning

**Power sources** • This equipment should be operated only from the power source indicated on the product. This equipment is intended to be used with a main power system with a grounded (neutral) conductor. The third (grounding) pin is a safety feature, do not attempt to bypass or disable it.

**Power disconnection** • To remove power from the equipment safely, remove all power cords from the rear of the equipment, or the desktop power module (if detachable), or from the power source receptacle (wall plug).

**Power cord protection** • Power cords should be routed so that they are not likely to be stepped on or pinched by items placed upon or against them.

**Servicing** • Refer all servicing to qualified service personnel. There are no user-serviceable parts inside. To prevent the risk of shock, do not attempt to service this equipment yourself because opening or removing covers may expose you to dangerous voltage or other hazards.

**Slots and openings** • If the equipment has slots or holes in the enclosure, these are provided to prevent overheating of sensitive components inside. These openings must never be blocked by other objects.

**Lithium battery** • There is a danger of explosion if battery is incorrectly replaced. Replace it only with the same or equivalent type recommended by the manufacturer. Dispose of used batteries according to the manufacturer's instructions.

## Avertissement

**Alimentations** • Ne faire fonctionner ce matériel qu'avec la source d'alimentation indiquée sur l'appareil. Ce matériel doit être utilisé avec une alimentation principale comportant un fil de terre (neutre). Le troisième contact (de mise à la terre) constitue un dispositif de sécurité : n'essayez pas de la contourner ni de la désactiver.

**Déconnexion de l'alimentation** • Pour mettre le matériel hors tension sans danger, déconnectez tous les cordons d'alimentation de l'arrière de l'appareil ou du module d'alimentation de bureau (s'il est amovible) ou encore de la prise secteur.

**Protection du cordon d'alimentation** • Acheminer les cordons d'alimentation de manière à ce que personne ne risque de marcher dessus et à ce qu'ils ne soient pas écrasés ou pincés par des objets.

**Réparation-maintenance** • Faire exécuter toutes les interventions de réparation-maintenance par un technicien qualifié. Aucun des éléments internes ne peut être réparé par l'utilisateur. Afin d'éviter tout danger d'électrocution, l'utilisateur ne doit pas essayer de procéder lui-même à ces opérations car l'ouverture ou le retrait des couvercles risquent de l'exposer à de hautes tensions et autres dangers.

**Fentes et orifices** • Si le boîtier de l'appareil comporte des fentes ou des orifices, ceux-ci servent à empêcher les composants internes sensibles de surchauffer. Ces ouvertures ne doivent jamais être bloquées par des objets.

**Lithium Batterie** • Il a danger d'explosion s'il y a remplacement incorrect de la batterie. Remplacer uniquement avec une batterie du même type ou d'un type équivalent recommandé par le constructeur. Mettre au rebut les batteries usagées conformément aux instructions du fabricant.

## Vorsicht

**Stromquellen** • Dieses Gerät sollte nur über die auf dem Produkt angegebene Stromquelle betrieben werden. Dieses Gerät wurde für eine Verwendung mit einer Hauptstromleitung mit einem geerdeten (neutralen) Leiter konzipiert. Der dritte Kontakt ist für einen Erdschluss, und stellt eine Sicherheitsfunktion dar. Diese sollte nicht umgangen oder außer Betrieb gesetzt werden.

**Stromunterbrechung** • Um das Gerät auf sichere Weise vom Netz zu trennen, sollten Sie alle Netzkabel aus der Rückseite des Gerätes, aus der externen Stromversorgung (falls dies möglich ist) oder aus der Wandsteckdose ziehen.

**Schutz des Netzkabels** • Netzkabel sollten stets so verlegt werden, daß sie nicht im Weg liegen und niemand darauf treten kann oder Objekte darauf- oder unmittelbar dagegen gestellt werden können.

**Wartung** • Alle Wartungsmaßnahmen sollten nur von qualifiziertem Servicepersonal durchgeführt werden. Die internen Komponenten des Gerätes sind wartungsfrei. Zur Vermeidung eines elektrischen Schocks versuchen Sie in keinem Fall, dieses Gerät selbst öffnen, da beim Entfernen der Abdeckungen die Gefahr eines elektrischen Schlags und/oder andere Gefahren bestehen.

**Schlitze und Öffnungen** • Wenn das Gerät Schlitze oder Löcher im Gehäuse aufweist, dienen diese zur Vermeidung einer Überhitzung der empfindlichen Teile im Inneren. Diese Öffnungen dürfen niemals von anderen Objekten blockiert werden.

**Lithium-Batterie** • Explosionsgefahr, falls die Batterie nicht richtig ersetzt wird. Ersetzen Sie verbrauchte Batterien nur durch den gleichen oder einen vergleichbaren Batterietyp, der auch vom Hersteller empfohlen wird. Entsorgen Sie verbrauchte Batterien bitte gemäß den Herstelleranweisungen.

## Advertencia

**Alimentación eléctrica** • Este equipo debe conectarse únicamente a la fuente/tipo de alimentación eléctrica indicada en el mismo. La alimentación eléctrica de este equipo debe provenir de un sistema de distribución general con conductor neutro a tierra. La tercera pata (puesta a tierra) es una medida de seguridad, no puentearla ni eliminarla.

**Desconexión de alimentación eléctrica** • Para desconectar con seguridad la acometida de alimentación eléctrica al equipo, desenchufar todos los cables de alimentación en el panel trasero del equipo, o desenchufar el módulo de alimentación (si fuera independiente), o desenchufar el cable del receptáculo de la pared.

**Protección del cables de alimentación** • Los cables de alimentación eléctrica se deben instalar en lugares donde no sean pisados ni apretados por objetos que se puedan apoyar sobre ellos.

**Reparaciones/mantenimiento** • Solicitar siempre los servicios técnicos de personal calificado. En el interior no hay partes a las que el usuario deba acceder. Para evitar riesgo de electrocución, no intentar personalmente la reparación/mantenimiento de este equipo, ya que al abrir o extraer las tapas puede quedar expuesto a voltajes peligrosos u otros riesgos.

**Ranuras y aberturas** • Si el equipo posee ranuras o orificios en su caja/alojamiento, es para evitar el sobrecalentamiento de componentes internos sensibles. Estas aberturas nunca se deben obstruir con otros objetos.

**Batería de litio** • Existe riesgo de explosión si esta batería se coloca en la posición incorrecta. Cambiar esta batería únicamente con el mismo tipo (o su equivalente) recomendado por el fabricante. Desachar las baterías usadas siguiendo las instrucciones del fabricante.

# Extron's Warranty

Extron Electronics warrants this product against defects in materials and workmanship for a period of three years from the date of purchase. In the event of malfunction during the warranty period attributable directly to faulty workmanship and/or materials, Extron Electronics will, at its option, repair or replace said products or components, to whatever extent it shall deem necessary to restore said product to proper operating condition, provided that it is returned within the warranty period, with proof of purchase and description of malfunction to:

**USA, Canada, South America, and Central America:**

Extron Electronics  
1001 East Ball Road  
Anaheim, CA 92805, USA

## Asia:

Extron Electronics, Asia  
135 Joo Seng Road, #04-01  
PM Industrial Bldg.  
Singapore 368363

**Europe, Africa, and the Middle East:**

Extron Electronics, Europe  
Beeldschermweg 6C  
3821 AH Amersfoort  
The Netherlands

## Japan:

Extron Electronics, Japan  
Kyodo Building  
16 Ichibancho  
Chiyoda-ku, Tokyo 102-0082  
Japan

This Limited Warranty does not apply if the fault has been caused by misuse, improper handling care, electrical or mechanical abuse, abnormal operating conditions or non-Extron authorized modification to the product.

*If it has been determined that the product is defective, please call Extron and ask for an Applications Engineer at (714) 491-1500 (USA), 31.33.453.4040 (Europe), 65.6383.4400 (Asia), or 81.3.3511.7655 (Japan) to receive an RA# (Return Authorization number). This will begin the repair process as quickly as possible.*

Units must be returned insured, with shipping charges prepaid. If not insured, you assume the risk of loss or damage during shipment. Returned units must include the serial number and a description of the problem, as well as the name of the person to contact in case there are any questions.

Extron Electronics makes no further warranties either expressed or implied with respect to the product and its quality, performance, merchantability, or fitness for any particular use. In no event will Extron Electronics be liable for direct, indirect, or consequential damages resulting from any defect in this product even if Extron Electronics has been advised of such damage.

Please note that laws vary from state to state and country to country, and that some provisions of this warranty may not apply to you.