

CMOS 4-BIT SINGLE CHIP MICROCOMPUTER

S1C63558

Technical Manual

S1C63558 Technical Hardware

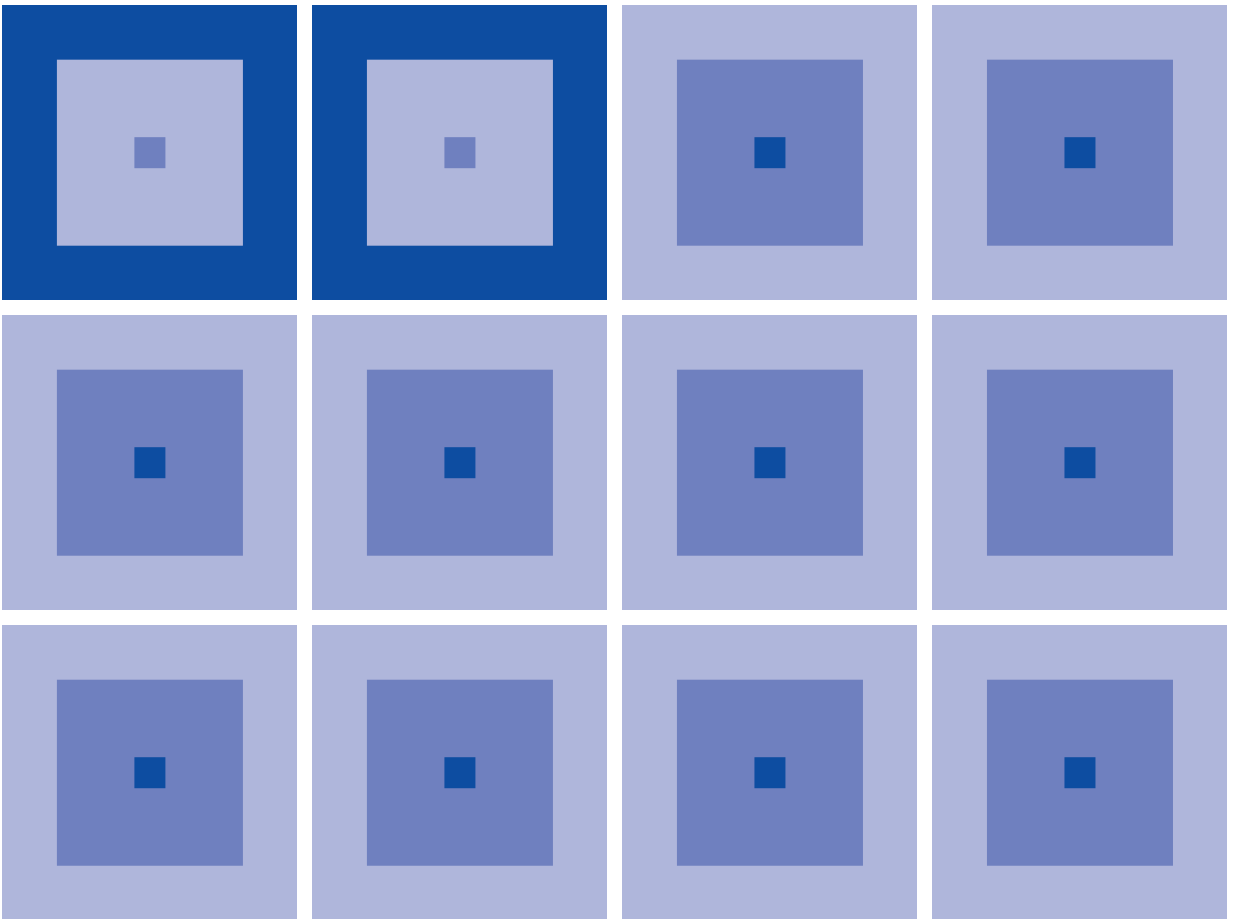

NOTICE

No part of this material may be reproduced or duplicated in any form or by any means without the written permission of Seiko Epson. Seiko Epson reserves the right to make changes to this material without notice. Seiko Epson does not assume any liability of any kind arising out of any inaccuracies contained in this material or due to its application or use in any product or circuit and, further, there is no representation that this material is applicable to products requiring high level reliability, such as medical products. Moreover, no license to any intellectual property rights is granted by implication or otherwise, and there is no representation or warranty that anything made in accordance with this material will be free from any patent or copyright infringement of a third party. This material or portions thereof may contain technology or the subject relating to strategic products under the control of the Foreign Exchange and Foreign Trade Law of Japan and may require an export license from the Ministry of International Trade and Industry or other approval from another government agency.

Revisions and Additions for this manual

Chapter	Section	Page	Item	Contents
2	2.1.2	8	Table 2.1.2.1 LCD drive voltage when generated internally	The table was revised.
4	4.7.3	49	Table 4.7.3.1 LCD drive voltage when generated internally	The table was revised.

The information of the product number change

Starting April 1, 2001, the product number has been changed as listed below. Please use the new product number when you place an order. For further information, please contact Epson sales representative.

Configuration of product number

Devices

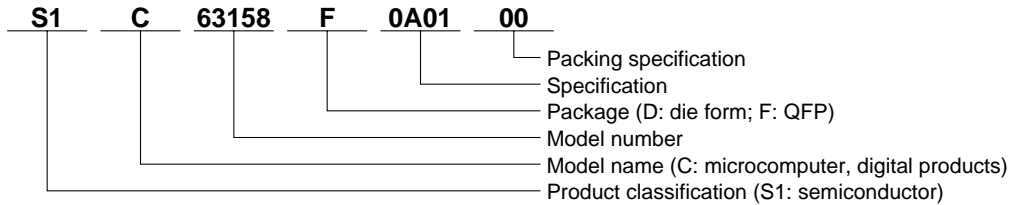

Development tools

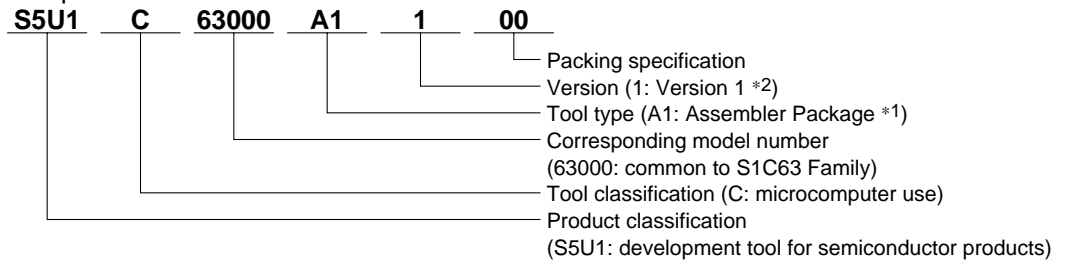

*1: For details about tool types, see the tables below. (In some manuals, tool types are represented by one digit.)

*2: Actual versions are not written in the manuals.

Comparison table between new and previous number

S1C63 Family processors

Previous No.	New No.
E0C63158	S1C63158
E0C63256	S1C63256
E0C63358	S1C63358
E0C63P366	S1C6P366
E0C63404	S1C63404
E0C63406	S1C63406
E0C63408	S1C63408
E0C63F408	S1C6F408
E0C63454	S1C63454
E0C63455	S1C63455
E0C63458	S1C63458
E0C63466	S1C63466
E0C63P466	S1C6P466

S1C63 Family peripheral products

Previous No.	New No.
E0C5250	S1C05250
E0C5251	S1C05251

Comparison table between new and previous number of development tools

Development tools for the S1C63 Family

Previous No.	New No.
ADP63366	S5U1C63366X
ADP63466	S5U1C63466X
ASM63	S5U1C63000A
GAM63001	S5U1C63000G
ICE63	S5U1C63000H1
PRC63001	S5U1C63001P
PRC63002	S5U1C63002P
PRC63004	S5U1C63004P
PRC63005	S5U1C63005P
PRC63006	S5U1C63006P
PRC63007	S5U1C63007P
URS63366	S5U1C63366Y

Development tools for the S1C63/88 Family

Previous No.	New No.
ADS00002	S5U1C88000X1
GWH00002	S5U1C88000W2
URM00002	S5U1C88000W1

CONTENTS

CHAPTER 1	OUTLINE	1
1.1	Features	1
1.2	Block Diagram	2
1.3	Pin Layout Diagram	3
1.4	Pin Description	4
1.5	Mask Option	5
CHAPTER 2	POWER SUPPLY AND INITIAL RESET	8
2.1	Power Supply	8
2.1.1	Voltage <VD1> for oscillation circuit and internal circuits	8
2.1.2	Voltage <VC1–VC5> for LCD driving	8
2.2	Initial Reset	9
2.2.1	Reset terminal ($\overline{\text{RESET}}$)	9
2.2.2	Simultaneous low input to terminals K00–K03	10
2.2.3	Internal register at initial resetting	10
2.2.4	Terminal settings at initial resetting	11
2.3	Test Terminal ($\overline{\text{TEST}}$)	11
CHAPTER 3	CPU, ROM, RAM	12
3.1	CPU	12
3.2	Code ROM	12
3.3	RAM	12
3.4	Data ROM	13
CHAPTER 4	PERIPHERAL CIRCUITS AND OPERATION	14
4.1	Memory Map	14
4.2	Watchdog Timer	23
4.2.1	Configuration of watchdog timer	23
4.2.2	Interrupt function	23
4.2.3	I/O memory of watchdog timer	24
4.2.4	Programming notes	24
4.3	Oscillation Circuit	25
4.3.1	Configuration of oscillation circuit	25
4.3.2	OSC1 oscillation circuit	25
4.3.3	OSC3 oscillation circuit	26
4.3.4	Switching the CPU operating clock	26
4.3.5	Clock frequency and instruction execution time	26
4.3.6	I/O memory of oscillation circuit	27
4.3.7	Programming notes	27
4.4	Input Ports (K00–K03 and K10–K13)	28
4.4.1	Configuration of input ports	28
4.4.2	Interrupt function	28
4.4.3	Mask option	29
4.4.4	I/O memory of input ports	30
4.4.5	Programming notes	32
4.5	Output Ports (R00–R03, R10–R13 and R20–R23)	33
4.5.1	Configuration of output ports	33
4.5.2	Mask option	33

4.5.3	High impedance control	34
4.5.4	Special output	34
4.5.5	I/O memory of output ports	37
4.5.6	Programming notes	40
4.6	I/O Ports (P00–P03, P10–P13, P20–P23 and P30–P33)	41
4.6.1	Configuration of I/O ports	41
4.6.2	Mask option	42
4.6.3	I/O control registers and input/output mode	42
4.6.4	Pull-up during input mode	42
4.6.5	Special outputs (CL, FR).....	43
4.6.6	I/O memory of I/O ports	44
4.6.7	Programming notes	48
4.7	LCD Driver (COM0–COM16, SEG0–SEG39)	49
4.7.1	Configuration of LCD driver	49
4.7.2	Mask option	49
4.7.3	Power supply for LCD driving.....	49
4.7.4	LCD display control (ON/OFF) and switching of duty.....	49
4.7.5	Display memory	51
4.7.6	LCD contrast adjustment	53
4.7.7	I/O memory of LCD driver	54
4.7.8	Programming notes	56
4.8	Clock Timer	57
4.8.1	Configuration of clock timer.....	57
4.8.2	Data reading and hold function	57
4.8.3	Interrupt function	58
4.8.4	I/O memory of clock timer	59
4.8.5	Programming notes	60
4.9	Stopwatch Timer	61
4.9.1	Configuration of stopwatch timer	61
4.9.2	Count-up pattern	61
4.9.3	Interrupt function	62
4.9.4	I/O memory of stopwatch timer	63
4.9.5	Programming notes	64
4.10	Programmable Timer	65
4.10.1	Configuration of programmable timer	65
4.10.2	Setting of initial value and counting down	66
4.10.3	Counter mode	67
4.10.4	Setting of input clock in timer mode	68
4.10.5	Interrupt function	69
4.10.6	Setting of TOUT output	69
4.10.7	Transfer rate setting for serial interface	70
4.10.8	I/O memory of programmable timer	71
4.10.9	Programming notes	76
4.11	Serial Interface	77
4.11.1	Configuration of serial interface	77
4.11.2	Mask option	78
4.11.3	Transfer modes	78
4.11.4	Clock source	80
4.11.5	Transmit-receive control	81
4.11.6	Operation of clock synchronous transfer.....	82
4.11.7	Operation of asynchronous transfer	86
4.11.8	Interrupt function	90
4.11.9	I/O memory of serial interface	92
4.11.10	Programming notes	99
4.12	Sound Generator	100
4.12.1	Configuration of sound generator	100
4.12.2	Buzzer output circuit	100

4.12.3 Control of buzzer output	101
4.12.4 Setting of buzzer frequency and sound level	102
4.12.5 Digital envelope	103
4.12.6 One-shot output	104
4.12.7 I/O memory of sound generator	105
4.12.8 Programming notes	108
4.13 SVD (Supply Voltage Detection) Circuit	109
4.13.1 Configuration of SVD circuit	109
4.13.2 Mask option	109
4.13.3 SVD operation	109
4.13.4 I/O memory of SVD circuit	110
4.13.5 Programming notes	111
4.14 Telephone Function (Tone/Pulse Dialer)	112
4.14.1 Configuration of tone/pulse dialer	112
4.14.2 Mask option	113
4.14.3 Operation of telephone function	113
4.14.4 Tone mode (DTMF)	116
4.14.5 Pulse mode (DP)	119
4.14.6 Pause	122
4.14.7 Flash	124
4.14.8 Hold-line	125
4.14.9 Interrupt	126
4.14.10 I/O memory of telephone function	127
4.14.11 Programming notes	135
4.15 FSK Demodulator	136
4.15.1 Configuration of FSK demodulator	136
4.15.2 Mask option	138
4.15.3 Ring/carrier detection and interrupt	139
4.15.4 Inputting FSK data	140
4.15.5 I/O memory of FSK demodulator	142
4.15.6 Programming notes	144
4.16 Interrupt and HALT	145
4.16.1 Interrupt factor	147
4.16.2 Interrupt mask	148
4.16.3 Interrupt vector	148
4.16.4 I/O memory of interrupt	149
4.16.5 Programming notes	151
CHAPTER 5 SUMMARY OF NOTES	152
5.1 Notes for Low Current Consumption	152
5.2 Summary of Notes by Function	153
5.3 Precautions on Mounting	157
CHAPTER 6 BASIC EXTERNAL WIRING DIAGRAM	159
CHAPTER 7 ELECTRICAL CHARACTERISTICS	160
7.1 Absolute Maximum Rating	160
7.2 Recommended Operating Conditions	160
7.3 DC Characteristics	161
7.4 Analog Circuit Characteristics and Power Current Consumption	162
7.5 Oscillation Characteristics	163
7.6 Serial Interface (1), (2) AC Characteristics	164
7.7 FSK Demodulator Characteristics	165

CONTENTS

7.8 Telephone Function Characteristics 166
7.9 Timing Chart 166
7.10 Characteristic Curves (reference value) 167

CHAPTER 8 PACKAGE 169

8.1 Plastic Package 169
8.2 Ceramic Package for Test Samples 170

CHAPTER 9 PAD LAYOUT 171

9.1 Diagram of Pad Layout 171
9.2 Pad Coordinates 172

CHAPTER 1 OUTLINE

The S1C63558 is a microcomputer which has a high-performance 4-bit CPU S1C63000 as the core CPU, ROM (8,192 words × 13 bits), RAM (5,120 words × 4 bits), serial interface, watchdog timer, programmable timer, time base counters (2 systems), SVD circuit, a dot-matrix LCD driver that can drive a maximum 40 segments × 17 commons, DTMF/DP generator, FSK demodulator and sound generator built-in. The S1C63558 features high speed operation and low current consumption in an operating voltage range (2.2 V to 5.5 V), this makes it suitable for applications working with batteries. It is also suitable for caller ID and portable data bank systems because it has a large capacity of RAM built-in.

1.1 Features

OSC1 oscillation circuit	32.768 kHz (Typ.) crystal oscillation circuit
OSC3 oscillation circuit	3.58 MHz (Typ.) ceramic oscillation circuit
Instruction set	Basic instruction: 46 types (411 instructions with all) Addressing mode: 8 types
Instruction execution time	During operation at 32.768 kHz: 61 μsec 122 μsec 183 μsec During operation at 3.58 MHz: 0.56 μsec 1.12 μsec 1.68 μsec
ROM capacity	Code ROM: 8,192 words × 13 bits Data ROM: 2,048 words × 4 bits (= 8K bits)
RAM capacity	Data memory: 5,120 words × 4 bits Display memory: 816 bits (192 words × 4 bits + 48 × 1 bit)
Input port	8 bits (Pull-up resistors may be supplemented *1)
Output port	12 bits (It is possible to switch the 8 bits to special output *2)
I/O port	16 bits (It is possible to switch the 2 bits to special output and the 4 bits to serial I/F input/output *2)
Serial interface	2 ch. (8-bit clock synchronous or asynchronous system is selectable)
LCD driver	40 segments × 8, 16 or 17 commons (*2)/48 segments × 8 commons (*1)
Time base counter	2 systems (Clock timer, stopwatch timer)
Programmable timer	Built-in, 2 inputs × 8 bits, with event counter function
Watchdog timer	Built-in
DTMF generator	Built-in
DP generator	Built-in
FSK demodulator	Built-in (Compatible with ITU-T V.23/Bell 202)
Sound generator	With envelope and 1-shot output functions
Supply voltage detection (SVD) circuit ..	12 values, programmable (2.20 V to 3.30 V) (It is possible to switch 1 value to the external voltage detection *1)
External interrupt	Input port interrupt: 2 systems
Internal interrupt	Clock timer interrupt: 4 systems Stopwatch timer interrupt: 2 systems Programmable timer interrupt: 2 systems Serial interface interrupt: 6 systems Dialer interrupt: 1 system FSK interrupt: 2 systems
Power supply voltage	2.2 V to 5.5 V
Operating temperature range	-20°C to 70°C
Current consumption (Typ.)	Low-speed operation (OSC1: crystal oscillation): During HALT (32 kHz) 3.0 V (LCD power OFF) 1.5 μA 3.0 V (LCD power ON) 4 μA During operation (32 kHz) 3.0 V (LCD power ON) 10 μA High-speed operation (OSC3: ceramic oscillation): During operation (3.58 MHz) 3.0 V (LCD power ON) 600 μA During FSK operation 5.5 V (LCD power ON) 1,800 μA
Package	QFP15-128pin (plastic) or chip *1: Can be selected with mask option *2: Can be selected with software

1.2 Block Diagram

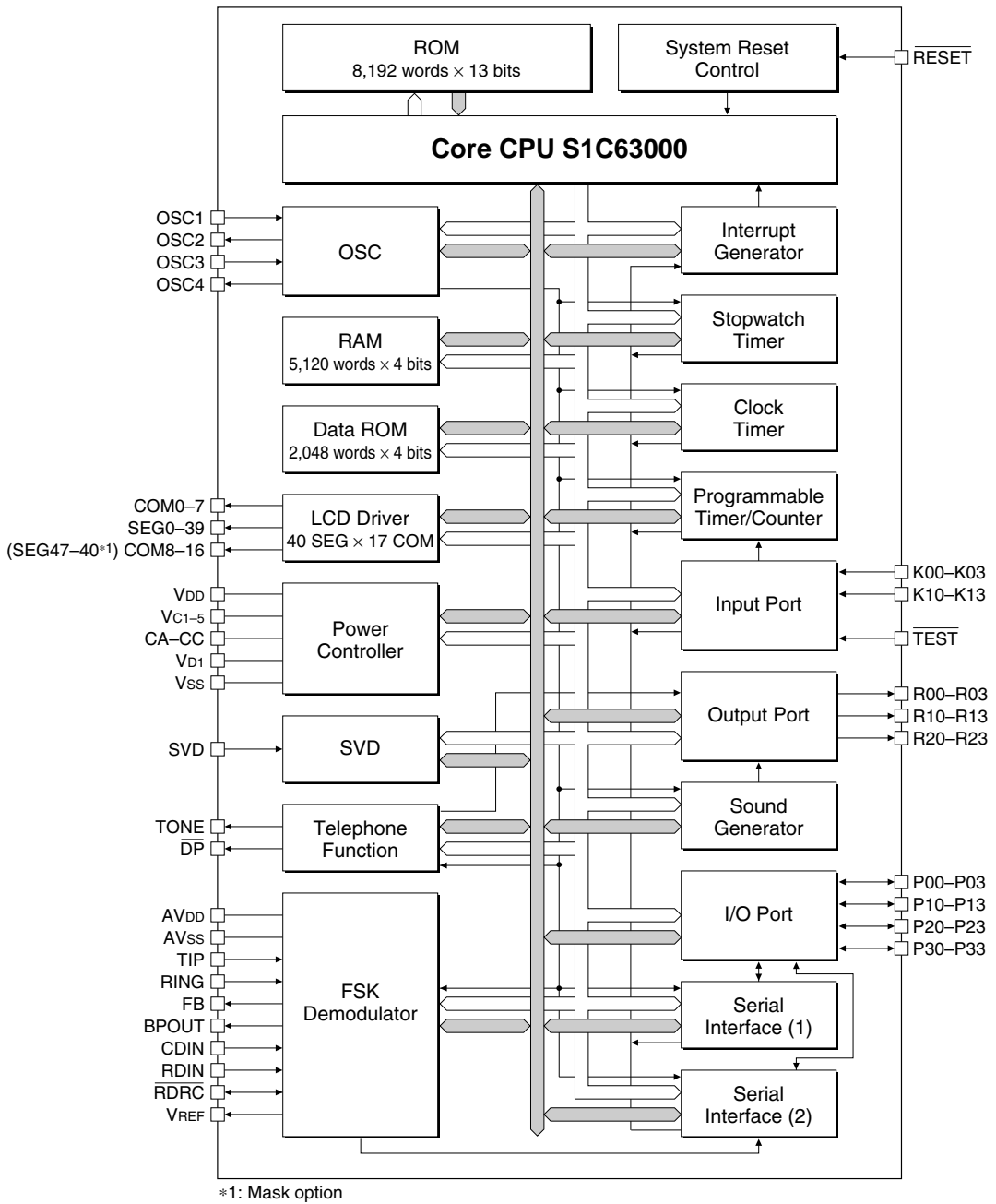
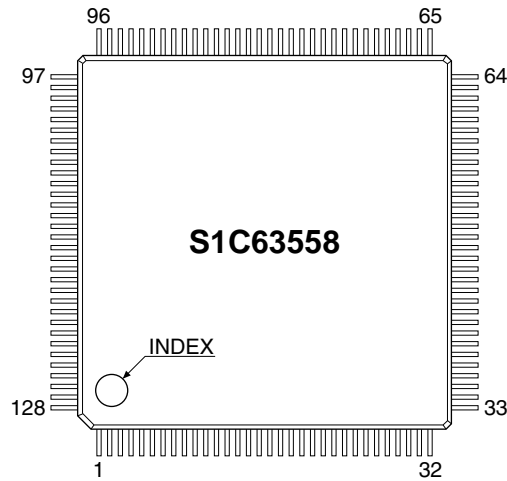

Fig. 1.2.1 Block diagram

1.3 Pin Layout Diagram

QFP15-128pin



No.	Pin name	No.	Pin name	No.	Pin name	No.	Pin name
1	N.C.	33	SEG4	65	N.C.	97	N.C.
2	SEG34	34	SEG3	66	R10	98	P00
3	SEG33	35	SEG2	67	R03	99	K13
4	SEG32	36	SEG1	68	R02	100	K12
5	SEG31	37	SEG0	69	R01	101	K11
6	SEG30	38	COM7	70	R00	102	K10
7	SEG29	39	COM6	71	CDIN	103	K03
8	SEG28	40	COM5	72	BPOUT	104	K02
9	SEG27	41	COM4	73	$\overline{\text{RDRC}}$	105	K01
10	SEG26	42	COM3	74	RDIN	106	K00
11	SEG25	43	COM2	75	VREF	107	SVD
12	SEG24	44	COM1	76	AVSS	108	Vc1
13	SEG23	45	COM0	77	FB	109	Vc23
14	SEG22	46	VSS	78	RING	110	Vc4
15	SEG21	47	OSC1	79	TIP	111	Vc5
16	SEG20	48	OSC2	80	AVDD	112	CC
17	SEG19	49	Vd1	81	P33	113	CB
18	SEG18	50	OSC3	82	P32	114	CA
19	SEG17	51	OSC4	83	P31	115	COM8/SEG47 *1
20	SEG16	52	VDD	84	P30	116	COM9/SEG47 *1
21	SEG15	53	$\overline{\text{RESET}}$	85	P23	117	COM10/SEG46 *1
22	SEG14	54	$\overline{\text{TEST}}$	86	P22	118	COM11/SEG45 *1
23	SEG13	55	TONE	87	P21	119	COM12/SEG44 *1
24	SEG12	56	$\overline{\text{DP}}$	88	P20	120	COM13/SEG43 *1
25	SEG11	57	R23	89	P13	121	COM14/SEG42 *1
26	SEG10	58	R22	90	P12	122	COM15/SEG41 *1
27	SEG9	59	R21	91	P11	123	COM16/SEG40 *1
28	SEG8	60	R20	92	P10	124	SEG39
29	SEG7	61	R13	93	P03	125	SEG38
30	SEG6	62	R12	94	P02	126	SEG37
31	SEG5	63	R11	95	P01	127	SEG36
32	N.C.	64	N.C.	96	N.C.	128	SEG35

*1: Mask option

N.C. : No Connection

Fig. 1.3.1 Pin layout diagram

1.4 Pin Description

Table 1.4.1 Pin description

Pin name	Pin No.	I/O	Function
VDD	52	–	Power (+) supply pin
VSS	46	–	Power (–) supply pin
V _{D1}	49	–	Oscillation system regulated voltage output pin
V _{C1} –V _{C5}	108–111	–	LCD system power supply pin (1/4 bias generated internally)
CA–CC	114–112	–	LCD system boosting/reducing capacitor connecting pin
OSC1	47	I	Crystal oscillation input pin
OSC2	48	O	Crystal oscillation output pin
OSC3	50	I	Ceramic oscillation input pin
OSC4	51	O	Ceramic oscillation output pin
K00–K03	106–103	I	Input port
K10–K13	102–99	I	Input port
P00–P03	98, 95–93	I/O	I/O port
P10–P13	92–89	I/O	I/O port (switching to serial I/F (1) input/output is possible by software)
P20	88	I/O	I/O port
P21	87	I/O	I/O port
P22	86	I/O	I/O port (switching to CL signal output is possible by software)
P23	85	I/O	I/O port (switching to FR signal output is possible by software)
P30–P33	84–81	I/O	I/O port (switching to serial I/F (2) input/output is possible by software)
R00	70	O	Output port (switching to XBZ signal output is possible by software)
R01	69	O	Output port (switching to BZ signal output is possible by software)
R02	68	O	Output port (switching to TOUT signal output is possible by software)
R03	67	O	Output port (switching to FOUT signal output is possible by software)
R10	66	O	Output port (switching to XTMUTE signal output is possible by software)
R11	63	O	Output port (switching to XRMUTE signal output is possible by software)
R12	62	O	Output port (switching to HDO signal output is possible by software)
R13	61	O	Output port (switching to HFO signal output is possible by software)
R20–R23	60–57	O	Output port
COM0–COM7	45–38	O	LCD common output pin (1/8, 1/16, 1/17 duty can be selected by software)
COM8–COM16 (SEG47–SEG40)	115–123	O	LCD common output pin or LCD segment output pin (mask option)
SEG0–SEG39	37–33, 31–2, 128–124	O	LCD segment output pin
SVD	107	I	SVD external voltage input pin
$\overline{\text{DP}}$	56	O	Dial pulse output pin
TONE	55	O	DTMF output pin
$\overline{\text{RESET}}$	53	I	Initial reset input pin
$\overline{\text{TEST}}$	54	I	Testing input pin
AVDD	80	–	Power (+) supply pin for FSK demodulator
AVSS	76	–	Power (–) supply pin for FSK demodulator
RDIN	74	I	Ring detection input pin
TIP	79	I	TIP input pin
RING	78	I	RING input pin
FB	77	O	Input amplifier output pin
BPOUT	72	O	Band-pass filter output pin
CDIN	71	I	Carrier detection input pin
$\overline{\text{RDRC}}$	73	I/O	I/O pin for connecting RC network
VREF	75	O	Reference voltage output pin (1/2 VDD)

1.5 Mask Option

Mask options shown below are provided for the S1C63558. Several hardware specifications are prepared in each mask option, and one of them can be selected according to the application. The function option generator FOG63558, that has been prepared as the development software tool of S1C63558, is used for this selection. Mask pattern of the IC is finally generated based on the data created by the FOG63558. Refer to the "S5U1C63558D Manual" for the FOG63558.

<Functions selectable with S1C63558 mask options>

(1) *External reset by simultaneous LOW input to the input port (K00–K03)*

This function resets the IC when several keys are pressed simultaneously. The mask option is used to select whether this function is used or not. Further when the function is used, a combination of the input ports (K00–K03), which are connected to the keys to be pressed simultaneously, can be selected. Refer to Section 2.2.2, "Simultaneous low input to terminals K00–K03", for details.

(2) *Time authorize circuit for the simultaneous LOW input reset function*

When using the external reset function (shown in 1 above), using the time authorize circuit or not can be selected by the mask option. The reset function works only when the input time of simultaneous LOW is more than the rule time if the time authorize circuit is being used. Refer to Section 2.2.2, "Simultaneous low input to terminals K00–K03", for details.

(3) *Input port pull-up resistor*

The mask option is used to select whether the pull-up resistor is supplemented to the input ports or not. It is possible to select for each bit of the input ports. Refer to Section 4.4.3, "Mask option", for details.

(4) *Output specification of the output port*

Either complementary output or N-channel open drain output can be selected as the output specification for the output ports. The selection is done in 1-bit units. Refer to Section 4.5.2, "Mask option", for details.

(5) *Output specification / pull-up resistor of the I/O ports*

Either complementary output or N-channel open drain output can be selected as the output specification when the I/O ports are in the output mode. The selection is done in 1-bit units.

Further, whether or not the pull-up resistors working in the input mode are supplemented can be selected. The selection is done in 1-bit units or 4-bit units depending on the I/O port.

1-bit unit: P20, P21, P22, P23

4-bit unit: P00–P03, P10–P13, P30–P33

Refer to Section 4.6.2, "Mask option", for details.

(6) *Configuration of the LCD segment*

The COM8–COM16 terminals allow selection of terminal specification between COM outputs and SEG45–SEG40 outputs.

Refer to Section 4.7.2, "Mask option", for details.

(7) *External voltage detection of SVD circuit*

External voltage (SVD terminal–Vss terminal) detection can be selected in addition to supply voltage (VDD terminal–Vss terminal) detection. The SVD terminal is used to input the external voltage to be detected.

Refer to Section 4.13.2, "Mask option", for details.

(8) Output specification of the \overline{DP} terminal

Either complementary output or N-channel open drain output can be selected as the output specification for the \overline{DP} (dial pulse output) terminal.
 Refer to Section 4.14.2, "Mask option", for details.

(9) Gain of FSK demodulator input amplifier

The gain of the FSK demodulator input amplifier can be either fixed at 1 using the internal feedback resistor or varied using external resistors.
 Refer to Section 4.15.2, "Mask option", for details.

(10) Output specification of other special output terminals

The following special output terminals are shared with the output (R) terminals or the I/O (P) terminals. Consequently, the output specification (complementary output or N-channel open drain output) of the shared terminal applies to the special output.

Special output signal	Shared port
XBZ, BZ, TOUT, FOUT	Output ports R00–R03
XRMUTE, XTMUTE, HDO, HFO	Output ports R10–R13
Serial interface input/output	I/O ports P10–P13
CL, FR	I/O ports P22, P23

<Mask option list>

The following is the option list for the S1C63558. Multiple selections are available in each option item as indicated in the option list. Refer to Chapter 4, "Peripheral Circuits and Operation", to select the specifications that meet the application system. Be sure to select the specifications for unused functions too, according to the instruction provided. Use fog63558 in the S5U1C63000A package for this selection. Refer to the "S5U1C63558D Manual" for details.

1. MULTIPLE KEY ENTRY RESET COMBINATION

- 1. Not Use
- 2. Use <K00, K01, K02, K03>
- 3. Use <K00, K01, K02>
- 4. Use <K00, K01>

2. MULTIPLE KEY ENTRY RESET TIME AUTHORIZE

- 1. Not Use
- 2. Use

3. INPUT PORT PULL UP RESISTOR

- | | | |
|-------|---|---|
| • K00 | <input type="checkbox"/> 1. With Resistor | <input type="checkbox"/> 2. Gate Direct |
| • K01 | <input type="checkbox"/> 1. With Resistor | <input type="checkbox"/> 2. Gate Direct |
| • K02 | <input type="checkbox"/> 1. With Resistor | <input type="checkbox"/> 2. Gate Direct |
| • K03 | <input type="checkbox"/> 1. With Resistor | <input type="checkbox"/> 2. Gate Direct |
| • K10 | <input type="checkbox"/> 1. With Resistor | <input type="checkbox"/> 2. Gate Direct |
| • K11 | <input type="checkbox"/> 1. With Resistor | <input type="checkbox"/> 2. Gate Direct |
| • K12 | <input type="checkbox"/> 1. With Resistor | <input type="checkbox"/> 2. Gate Direct |
| • K13 | <input type="checkbox"/> 1. With Resistor | <input type="checkbox"/> 2. Gate Direct |

4. OUTPUT PORT OUTPUT SPECIFICATION

- | | | |
|-------|---|---|
| • R00 | <input type="checkbox"/> 1. Complementary | <input type="checkbox"/> 2. Nch-OpenDrain |
| • R01 | <input type="checkbox"/> 1. Complementary | <input type="checkbox"/> 2. Nch-OpenDrain |
| • R02 | <input type="checkbox"/> 1. Complementary | <input type="checkbox"/> 2. Nch-OpenDrain |
| • R03 | <input type="checkbox"/> 1. Complementary | <input type="checkbox"/> 2. Nch-OpenDrain |
| • R10 | <input type="checkbox"/> 1. Complementary | <input type="checkbox"/> 2. Nch-OpenDrain |
| • R11 | <input type="checkbox"/> 1. Complementary | <input type="checkbox"/> 2. Nch-OpenDrain |
| • R12 | <input type="checkbox"/> 1. Complementary | <input type="checkbox"/> 2. Nch-OpenDrain |
| • R13 | <input type="checkbox"/> 1. Complementary | <input type="checkbox"/> 2. Nch-OpenDrain |
| • R20 | <input type="checkbox"/> 1. Complementary | <input type="checkbox"/> 2. Nch-OpenDrain |
| • R21 | <input type="checkbox"/> 1. Complementary | <input type="checkbox"/> 2. Nch-OpenDrain |
| • R22 | <input type="checkbox"/> 1. Complementary | <input type="checkbox"/> 2. Nch-OpenDrain |
| • R23 | <input type="checkbox"/> 1. Complementary | <input type="checkbox"/> 2. Nch-OpenDrain |

5. I/O PORT OUTPUT SPECIFICATION

- P00 1. Complementary 2. Nch-OpenDrain
- P01 1. Complementary 2. Nch-OpenDrain
- P02 1. Complementary 2. Nch-OpenDrain
- P03 1. Complementary 2. Nch-OpenDrain
- P10 1. Complementary 2. Nch-OpenDrain
- P11 1. Complementary 2. Nch-OpenDrain
- P12 1. Complementary 2. Nch-OpenDrain
- P13 1. Complementary 2. Nch-OpenDrain
- P20 1. Complementary 2. Nch-OpenDrain
- P21 1. Complementary 2. Nch-OpenDrain
- P22 1. Complementary 2. Nch-OpenDrain
- P23 1. Complementary 2. Nch-OpenDrain
- P30 1. Complementary 2. Nch-OpenDrain
- P31 1. Complementary 2. Nch-OpenDrain
- P32 1. Complementary 2. Nch-OpenDrain
- P33 1. Complementary 2. Nch-OpenDrain

6. I/O PORT PULL UP RESISTOR

- P0x 1. With Resistor 2. Gate Direct
- P1x 1. With Resistor 2. Gate Direct
- P20 1. With Resistor 2. Gate Direct
- P21 1. With Resistor 2. Gate Direct
- P22 1. With Resistor 2. Gate Direct
- P23 1. With Resistor 2. Gate Direct
- P3x 1. With Resistor 2. Gate Direct

7. DP PORT OUTPUT SPECIFICATION

- 1. Complementary 2. Nch-OpenDrain

8. SVD EXTERNAL VOLTAGE DETECTION

- 1. Not Use
- 2. Use

9. LCD DRIVER SPECIFICATION

- 1. 40 seg * 17 com
- 2. 48 seg * 8 com

10. FSK INTERNAL FEEDBACK RESISTOR

- 1. Use
- 2. Not Use

CHAPTER 2 POWER SUPPLY AND INITIAL RESET

2.1 Power Supply

The S1C63558 operating power voltage is as follows:

Supply voltage $V_{DD} = 2.2\text{ V to }5.5\text{ V}$

The S1C63558 operates by applying a single power supply within the above range between V_{DD} and V_{SS} . The S1C63558 itself generates the voltage necessary for all the internal circuits by the built-in power supply circuits shown in Table 2.1.1.

Table 2.1.1 Power supply circuits

Circuit	Power supply circuit	Output voltage
Oscillation and internal circuits	Oscillation system voltage regulator	V_{D1}
LCD driver	LCD system voltage circuit	$V_{C1}\text{--}V_{C5}$
FSK demodulator	Analog system power supply	AV_{DD}, AV_{SS}

- Note:
- Do not drive external loads with the output voltage from the internal power supply circuits.
 - See Chapter 7, "Electrical Characteristics", for voltage values and drive capability.

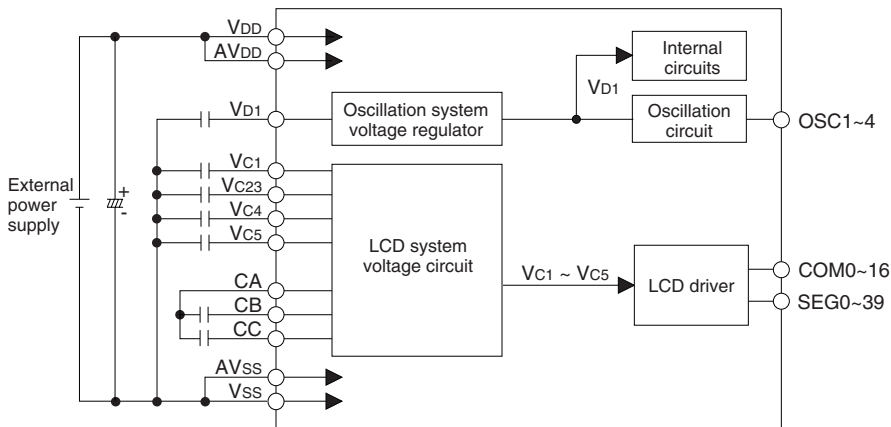

Fig. 2.1.1 Configuration of power supply

2.1.1 Voltage $\langle V_{D1} \rangle$ for oscillation circuit and internal circuits

V_{D1} is a voltage for the oscillation circuit and the internal logic circuits, and is generated by the oscillation system voltage regulator for stabilizing the oscillation. The V_{D1} voltage is fixed at 2.1 V, so it is not necessary to control by software.

2.1.2 Voltage $\langle V_{C1}\text{--}V_{C5} \rangle$ for LCD driving

V_{C1}, V_{C23}, V_{C4} and V_{C5} are the LCD (1/4 bias) drive voltages generated by the LCD system voltage circuit. These four output voltages can only be supplied to the externally expanded LCD driver. The LCD system voltage circuit generates V_{C23} with the voltage regulator built-in, and generates three other voltages by boosting or reducing the voltage of V_{C23} . Table 2.1.2.1 shows the V_{C1}, V_{C23}, V_{C4} and V_{C5} voltage values and boost/reduce status.

Table 2.1.2.1 LCD drive voltage when generated internally

LCD drive voltage	Boost/reduce status	Voltage value [V]
V_{C1}	$V_{C2} \times 0.5$	1.13
V_{C23}	V_{C2} (standard)	2.25
V_{C4}	$V_{C2} \times 1.5$	3.38
V_{C5}	$V_{C2} \times 2$	4.50

Note: The LCD drive voltage can be adjusted by the software (see Section 4.7.5). Values in the above table are typical values.

Refer to Section 4.7, "LCD Driver", for control of the LCD drive voltage.

2.2 Initial Reset

To initialize the S1C63558 circuits, initial reset must be executed. There are two ways of doing this.

- (1) External initial reset by the $\overline{\text{RESET}}$ terminal
- (2) External initial reset by simultaneous low input to terminals K00–K03 (mask option setting)

The circuits are initialized by either (1) or (2). When the power is turned on, be sure to initialize using the reset function. It is not guaranteed that the circuits are initialized by only turning the power on.

Figure 2.2.1 shows the configuration of the initial reset circuit.

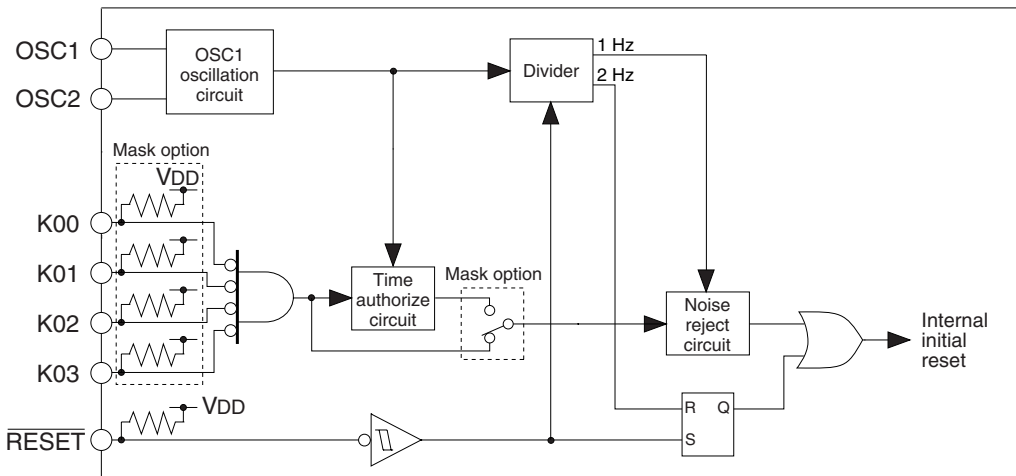

Fig. 2.2.1 Configuration of initial reset circuit

2.2.1 Reset terminal ($\overline{\text{RESET}}$)

Initial reset can be executed externally by setting the reset terminal to a low level (V_{SS}). After that the initial reset is released by setting the reset terminal to a high level (V_{DD}) and the CPU starts operating. The reset input signal is maintained by the RS latch and becomes the internal initial reset signal. The RS latch is designed to be released by a 2 Hz signal (high) that is divided by the OSC1 clock. Therefore in normal operation, a maximum of 250 msec (when $f_{OSC1} = 32.768 \text{ kHz}$) is needed until the internal initial reset is released after the reset terminal goes to high level. Be sure to maintain a reset input of 0.1 msec or more.

However, when turning the power on, the reset terminal should be set at a low level as in the timing shown in Figure 2.2.1.1.

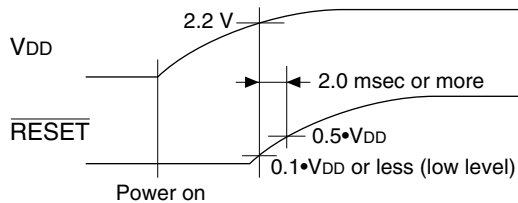

Fig. 2.2.1.1 Initial reset at power on

The reset terminal should be set to $0.1 \cdot V_{DD}$ or less (low level) until the supply voltage becomes 2.2 V or more. After that, a level of $0.5 \cdot V_{DD}$ or less should be maintained more than 2.0 msec.

2.2.2 Simultaneous low input to terminals K00–K03

Another way of executing initial reset externally is to input a low signal simultaneously to the input ports (K00–K03) selected with the mask option.

Since this initial reset passes through the noise reject circuit, maintain the specified input port terminals at low level for at least 1.5 msec (when the oscillation frequency f_{OSC1} is 32.768 kHz) during normal operation. The noise reject circuit does not operate immediately after turning the power on until the oscillation circuit starts oscillating. Therefore, maintain the specified input port terminals at low level for at least 1.5 msec (when the oscillation frequency f_{OSC1} is 32.768 kHz) after oscillation starts.

Table 2.2.2.1 shows the combinations of input ports (K00–K03) that can be selected with the mask option.

Table 2.2.2.1 Combinations of input ports

1	Not use
2	K00*K01*K02*K03
3	K00*K01*K02
4	K00*K01

When, for instance, mask option 2 (K00*K01*K02*K03) is selected, initial reset is executed when the signals input to the four ports K00–K03 are all low at the same time. When 3 or 4 is selected, the initial reset is done when a key entry including a combination of selected input ports is made.

Further, the time authorize circuit can be selected with the mask option. The time authorize circuit checks the input time of the simultaneous low input and performs initial reset if that time is the defined time (1 to 2 sec) or more.

If using this function, make sure that the specified ports do not go low at the same time during ordinary operation.

2.2.3 Internal register at initial resetting

Initial reset initializes the CPU as shown in Table 2.2.3.1.

The registers and flags which are not initialized by initial reset should be initialized in the program if necessary.

In particular, the stack pointers SP1 and SP2 must be set as a pair because all the interrupts including NMI are masked after initial reset until both the SP1 and SP2 stack pointers are set with software.

When data is written to the EXT register, the E flag is set and the following instruction will be executed in the extended addressing mode. If an instruction which does not permit extended operation is used as the following instruction, the operation is not guaranteed. Therefore, do not write data to the EXT register for initialization only.

Refer to the "S1C63000 Core CPU Manual" for extended addressing and usable instructions.

Table 2.2.3.1 Initial values

CPU core				Peripheral circuits		
Name	Symbol	Number of bits	Setting value	Name	Number of bits	Setting value
Data register A	A	4	Undefined	RAM	4	Undefined
Data register B	B	4	Undefined	Display memory	4	Undefined
Extension register EXT	EXT	8	Undefined	Other peripheral circuits	–	*
Index register X	X	16	Undefined			
Index register Y	Y	16	Undefined			
Program counter	PC	16	0110H			
Stack pointer SP1	SP1	8	Undefined			
Stack pointer SP2	SP2	8	Undefined			
Zero flag	Z	1	Undefined			
Carry flag	C	1	Undefined			
Interrupt flag	I	1	0			
Extension flag	E	1	0			
Queue register	Q	16	Undefined			

* See Section 4.1, "Memory Map".

2.2.4 Terminal settings at initial resetting

The output port (R) terminals and I/O port (P) terminals are shared with special output terminals and input/output terminals of the serial interface. These functions are selected by the software. At initial reset, these terminals are set to the general purpose output port terminals and I/O port terminals. Set them according to the system in the initial routine. In addition, take care of the initial status of output terminals when designing a system.

Table 2.2.4.1 shows the list of the shared terminal settings.

Table 2.2.4.1(a) List of shared terminal settings (Rxx)

Terminal name	Terminal status at initial reset	Special output							
		FOUT	TOUT	BZ	XBZ	HFO	HDO	XRMUTE	XTMUTE
R00	R00 (HIGH output)				XBZ				
R01	R01 (HIGH output)			BZ					
R02	R02 (HIGH output)		TOUT						
R03	R03 (HIGH output)	FOUT							
R10	R10 (HIGH output)								XTMUTE
R11	R11 (HIGH output)							XRMUTE	
R12	R12 (HIGH output)						HDO		
R13	R13 (HIGH output)					HFO			
R20–R23	R20–R23 (HIGH output)								

Table 2.2.4.1(b) List of shared terminal settings (Pxx)

Terminal name	Terminal status at initial reset	Special output		Serial I/F *2		
		CL	FR	Async.	Clk-sync. Master	Clk-sync. Slave
P00–P03	P00–P03 (Input & Pull-up *1)					
P10	P10 (Input & Pull-up *1)			SIN(I)	SIN(I)	SIN(I)
P11	P11 (Input & Pull-up *1)			SOUT(O)	SOUT(O)	SOUT(O)
P12	P12 (Input & Pull-up *1)				SCLK(O)	SCLK(I)
P13	P13 (Input & Pull-up *1)					SRDY(O)
P20	P20 (Input & Pull-up *1)					
P21	P21 (Input & Pull-up *1)					
P22	P22 (Input & Pull-up *1)	CL				
P23	P23 (Input & Pull-up *1)		FR			
P30	P30 (Input & Pull-up *1)			SIN(I)	SIN(I)	SIN(I)
P31	P31 (Input & Pull-up *1)			SOUT(O)	SOUT(O)	SOUT(O)
P32	P32 (Input & Pull-up *1)				SCLK(O)	SCLK(I)
P33	P33 (Input & Pull-up *1)					SRDY(O)

*1 When "with pull-up" is selected by mask option (high impedance when "gate direct" is selected)

*2 The P10–P13 I/O terminals are used for serial I/F (1) and the P30–P33 I/O terminals are for serial I/F (2).

For setting procedure of the functions, see explanations for each of the peripheral circuits.

2.3 Test Terminal ($\overline{\text{TEST}}$)

This is the terminal used for the factory inspection of the IC. During normal operation, connect the $\overline{\text{TEST}}$ terminal to VDD.

CHAPTER 3 CPU, ROM, RAM

3.1 CPU

The S1C63558 has a 4-bit core CPU S1C63000 built-in as its CPU part. Refer to the "S1C63000 Core CPU Manual" for the S1C63000.

Note: The SLP instruction cannot be used because the SLEEP operation is not assumed in the S1C63558.

3.2 Code ROM

The built-in code ROM is a mask ROM for loading programs, and has a capacity of 8,192 steps × 13 bits. The core CPU can linearly access the program space up to step FFFFH from step 0000H, however, the program area of the S1C63558 is step 0000H to step 1FFFH. The program start address after initial reset is assigned to step 0110H. The non-maskable interrupt (NMI) vector and hardware interrupt vectors are allocated to step 0100H and steps 0104H–010EH, respectively.

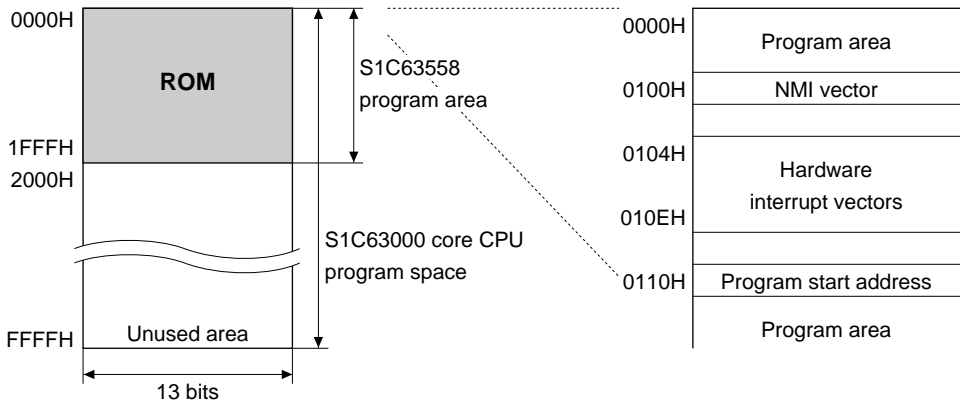

Fig. 3.2.1 Configuration of code ROM

3.3 RAM

The RAM is a data memory for storing various kinds of data, and has a capacity of 5,120 words × 4 bits. The RAM area is assigned to addresses 0000H to 13FFH on the data memory map. Addresses 0100H to 01FFH are 4-bit/16-bit data accessible areas and in other areas it is only possible to access 4-bit data. When programming, keep the following points in mind.

- (1) Part of the RAM area is used as a stack area for subroutine call and register evacuation, so pay attention not to overlap the data area and stack area.
- (2) The S1C63000 core CPU handles the stack using the stack pointer for 4-bit data (SP2) and the stack pointer for 16-bit data (SP1).

16-bit data are accessed in stack handling by SP1, therefore, this stack area should be allocated to the area where 4-bit/16-bit access is possible (0100H to 01FFH). The stack pointers SP1 and SP2 change cyclically within their respective range: the range of SP1 is 0000H to 03FFH and the range of SP2 is 0000H to 00FFH. Therefore, pay attention to the SP1 value because it may be set to 0200H or more exceeding the 4-bit/16-bit accessible range in the S1C63558 or it may be set to 00FFH or less. Memory accesses except for stack operations by SP1 are 4-bit data access.

After initial reset, all the interrupts including NMI are masked until both the stack pointers SP1 and SP2 are set by software. Further, if either SP1 or SP2 is re-set when both are set already, the interrupts including NMI are masked again until the other is re-set. Therefore, the settings of SP1 and SP2 must be done as a pair.

- (3) Subroutine calls use 4 words (for PC evacuation) in the stack area for 16-bit data (SP1). Interrupts use 4 words (for PC evacuation) in the stack area for 16-bit data (SP1) and 1 word (for F register evacuation) in the stack area for 4-bit data.

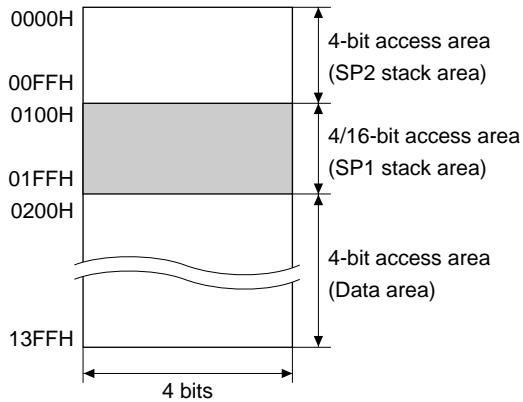

Fig. 3.3.1 Configuration of data RAM

3.4 Data ROM

The data ROM is a mask ROM for loading various static data such as a character generator, and has a capacity of 2,048 words \times 4 bits. The data ROM is assigned to addresses 8000H to 87FFH on the data memory map, and the data can be read using the same data memory access instructions as the RAM.

CHAPTER 4 PERIPHERAL CIRCUITS AND OPERATION

The peripheral circuits of S1C63558 (timer, I/O, etc.) are interfaced with the CPU in the memory mapped I/O method. Thus, all the peripheral circuits can be controlled by accessing the I/O memory on the memory map using the memory operation instructions. The following sections explain the detailed operation of each peripheral circuit.

4.1 Memory Map

The S1C63558 data memory consists of 5,120-word RAM, 2,048-word data ROM, 816-bit display memory and 97-word peripheral I/O memory. Figure 4.1.1 shows the overall memory map of the S1C63558, and Tables 4.1.1(a)–(h) the peripheral circuits' (I/O space) memory maps.

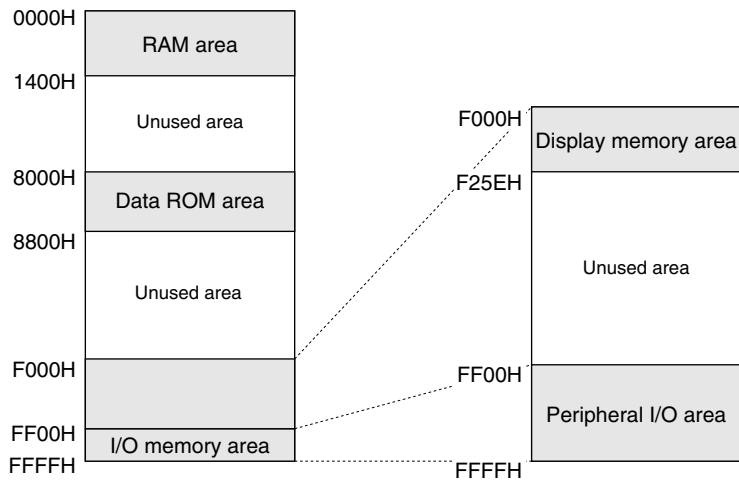

Fig. 4.1.1 Memory map

Note: Memory is not implemented in unused areas within the memory map. Further, some non-implementation areas and unused (access prohibition) areas exist in the display memory area and the peripheral I/O area. If the program that accesses these areas is generated, its operation cannot be guaranteed. Refer to Section 4.7.5, "Display memory", for the display memory, and the I/O memory maps shown in Tables 4.1.1 (a)–(h) for the peripheral I/O area.

Table 4.1.1 (a) I/O memory map (FF00H–FF18H)

Address	Register				Name	Init *1	1	0	Comment
	D3	D2	D1	D0					
FF00H	CLKCHG	OSCC	0	Dummy	CLKCHG	0	OSC3	OSC1	CPU clock switch
					OSCC	0	On	Off	OSC3 oscillation On/Off
	R/W		R	R/W	Dummy	0 *3	- *2		Unused
					Dummy	0			General-purpose register
FF04H	SVDS3	SVDS2	SVDS1	SVDS0	SVDS3	0			SVD criteria voltage setting [SVDS3-0] 0 1 2 3 4 5 6 7 Voltage(V) 2.20/1.05 2.20 2.20 2.20 2.20 2.30 2.40 2.50 [SVDS3-0] 8 9 10 11 12 13 14 15 Voltage(V) 2.60 2.70 2.80 2.90 3.00 3.10 3.20 3.30
					SVDS2	0			
	R/W				SVDS1	0			
					SVDS0	0			
FF05H	0	0	SVDDT	SVDON	0 *3	- *2			Unused
					0 *3	- *2			Unused
	R			R/W	SVDDT	0	Low	Normal	SVD evaluation data
					SVDON	0	On	Off	SVD circuit On/Off
FF06H	FOUTE	0	FOFQ1	FOFQ0	FOUTE	0	FOUT	DC	R03 output selection (R03 should be fixed at "1".)
					0 *3	- *2			Unused
	R/W	R	R/W		FOFQ1	0			FOUT frequency selection [FOFQ1, 0] 0 1 2 3 Frequency fosc1/64 fosc1/8 fosc1 fosc3
					FOFQ0	0			
FF07H	0	0	WDEN	WDRST	0 *3	- *2			Unused
					0 *3	- *2			Unused
	R		R/W	W	WDEN	1	Enable	Disable	Watchdog timer enable
					WDRST *3	Reset	Reset	Invalid	Watchdog timer reset (writing)
FF10H	TPS	0	MB	DRS	TPS	0	Pulse	Tone	Tone / pulse mode selection
					0 *3	- *2			Unused
	R/W	R	R/W		MB	0	33.3/66.6	40/60	Make : Break ratio selection
					DRS	0	20pps	10pps	Dialing pulse rate selection
FF11H	PTS3	PTS2	PTS1	PTS0	PTS3	0			Pause time selection (initial value: 4 sec) [PTS3-0] 0 1 2 3 4 5 6 7 Time(sec) × 1 2 3 4 5 6 7 [PTS3-0] 8 9 10 11 12 13 14 15 Time(sec) 8 9 10 11 12 13 14 15
					PTS2	1			
	R/W				PTS1	0			
					PTS0	0			
FF12H	FTS3	FTS2	FTS1	FTS0	FTS3	0			Flash time selection (initial value: 563 ms) [FTS3-0] 0 1 2 3 4 5 6 7 Time(ms) × 94 188 281 375 469 563 656 [FTS3-0] 8 9 10 11 12 13 14 15 Time(ms) 750 844 938 1031 1125 1219 1313 1406
					FTS2	1			
	R/W				FTS1	1			
					FTS0	0			
FF13H	CHFO	CHDO	CRMO	CTMO	CHFO	0	HFO	DC	R13 output selection (R13 should be fixed at "1".)
					CHDO	0	HDO	DC	R12 output selection (R12 should be fixed at "1".)
	R/W				CRMO	0	XRMUTE	DC	R11 output selection (R11 should be fixed at "1".)
					CTMO	0	XTMUTE	DC	R10 output selection (R10 should be fixed at "1".)
FF14H	HF	HOLD	PAUSE	FLASH	HF	0	Yes	No	Hand free
					HOLD	0	On	Off	Hold-line function
	R/W		W		PAUSE *3	0	Yes	No	Pause function
					FLASH *3	0	Yes	No	Flash function
FF15H	IDP3	IDP2	IDP1	IDP0	IDP3	1			Inter-digit pause selection for dial pulse (initial value: 750 ms) [IDP3-0] 0 1 2 3 4 5 6 7 Time(ms) × 94 188 281 375 469 563 656 [IDP3-0] 8 9 10 11 12 13 14 15 Time(ms) 750 844 938 1031 1125 1219 1313 1406
					IDP2	0			
	R/W				IDP1	0			
					IDP0	0			
FF16H	CTO	0	SINR	SINC	CTO	0	On	Off	Continuous tone output On/Off
					0 *3	- *2			Unused
	R/W	R	R/W		SINR	1	Enable	Disable	DTMF row frequency output enable
					SINC	1	Enable	Disable	DTMF column frequency output enable
FF17H	TCD3	TCD2	TCD1	TCD0	TCD3	0			Telephone code for dialing [TCD3-0] 0 1 2 3 4 5 6 7 DTMF (R1C4)(R1C1)(R1C2)(R1C3)(R2C2)(R2C3)(R3C1) DP × 1 2 3 4 5 6 7 [TCD3-0] 8 9 10 11 12 13 14 15 DTMF (R3C2)(R3C3)(R4C2)(R4C3)(R4C1)(R2C4)(R4C4)(R3C4) DP 8 9 10 11 12 13 14 15
					TCD2	0			
	R/W				TCD1	0			
					TCD0	0			
FF18H	HSON	0	CRMUT	CTMUT	HSON	0	Off	On	Hook switch On/Off
					0 *3	- *2			Unused
	R/W	R	R/W		CRMUT	1	Mute	0	Receive mute control
					CTMUT	1	Mute	0	Transmit mute control

Remarks

*1 Initial value at initial reset
*2 Not set in the circuit

*3 Constantly "0" when being read
*4 Depends on the input status of the RDIN terminal

Table 4.1.1 (b) I/O memory map (FF20H–FF42H)

Address	Register				Name	Init *1	1	0	Comment
	D3	D2	D1	D0					
FF20H	SIK03	SIK02	SIK01	SIK00	SIK03	0	Enable	Disable	K00–K03 interrupt selection register
					SIK02	0	Enable	Disable	
					SIK01	0	Enable	Disable	
					SIK00	0	Enable	Disable	
R/W									
FF21H	K03	K02	K01	K00	K03	–*2	High	Low	K00–K03 input port data
					K02	–*2	High	Low	
					K01	–*2	High	Low	
					K00	–*2	High	Low	
R									
FF22H	KCP03	KCP02	KCP01	KCP00	KCP03	1	↓	↑	K00–K03 input comparison register
					KCP02	1	↓	↑	
					KCP01	1	↓	↑	
					KCP00	1	↓	↑	
R/W									
FF24H	SIK13	SIK12	SIK11	SIK10	SIK13	0	Enable	Disable	K10–K13 interrupt selection register
					SIK12	0	Enable	Disable	
					SIK11	0	Enable	Disable	
					SIK10	0	Enable	Disable	
R/W									
FF25H	K13 (E/IN)	K12	K11	K10	K13	–*2	High	Low	K10–K13 input port data
					K12	–*2	High	Low	
					K11	–*2	High	Low	
					K10	–*2	High	Low	
R									
FF26H	KCP13	KCP12	KCP11	KCP10	KCP13	1	↓	↑	K10–K13 input comparison register
					KCP12	1	↓	↑	
					KCP11	1	↓	↑	
					KCP10	1	↓	↑	
R/W									
FF30H	R03HIZ	R02HIZ	R01HIZ	R00HIZ	R03HIZ	0	Hi-Z	Output	R03 (FOUTE=0)/FOUT (FOUTE=1) Hi-z control
					R02HIZ	0	Hi-Z	Output	R02 (PTOUT=0)/TOUT (PTOUT=1) Hi-z control
					R01HIZ	0	Hi-Z	Output	R01 (BZOUT=0)/BZ (BZOUT=1) Hi-z control
					R00HIZ	0	Hi-Z	Output	R00 (XBZOUT=0)/XBZ (XBZOUT=1) Hi-z control
R/W									
FF31H	R03 (FOUT)	R02 (TOUT)	R01 (BZ)	R00 (XBZ)	R03	1	High	Low	R03 output port data (FOUTE=0) Fix at "1" when FOUT is used.
					R02	1	High	Low	R02 output port data (PTOUT=0) Fix at "1" when TOUT is used.
					R01	1	High	Low	R01 output port data (BZOUT=0) Fix at "1" when BZ is used.
					R00	1	High	Low	R00 output port data (XBZOUT=0) Fix at "1" when XBZ is used.
R/W									
FF32H	R13HIZ	R12HIZ	R11HIZ	R10HIZ	R13HIZ	0	Hi-Z	Output	R13 (CHFO=0)/HFO (CHFO=1) Hi-z control
					R12HIZ	0	Hi-Z	Output	R12 (CHDO=0)/HDO (CHDO=1) Hi-z control
					R11HIZ	0	Hi-Z	Output	R11 (CRMO=0)/XRMUTE (CRMO=1) Hi-z control
					R10HIZ	0	Hi-Z	Output	R10 (CTMO=0)/XTMUTE (CTMO=1) Hi-z control
R/W									
FF33H	R13 (HFO)	R12 (HDO)	R11 (XRMUTE)	R10 (XTMUTE)	R13	1	High	Low	R13 output port data (CHFO=0) Fix at "1" when HFO is used.
					R12	1	High	Low	R12 output port data (CHDO=0) Fix at "1" when HDO is used.
					R11	1	High	Low	R11 output port data (CRMO=0) Fix at "1" when XRMUTE is used.
					R10	1	High	Low	R10 output port data (CTMO=0) Fix at "1" when XTMUTE is used.
R/W									
FF34H	R23HIZ	R22HIZ	R21HIZ	R20HIZ	R23HIZ	0	Hi-Z	Output	R20–R23 Hi-z control
					R22HIZ	0	Hi-Z	Output	
					R21HIZ	0	Hi-Z	Output	
					R20HIZ	0	Hi-Z	Output	
R/W									
FF35H	R23	R22	R21	R20	R23	1	High	Low	R20–R23 output port data
					R22	1	High	Low	
					R21	1	High	Low	
					R20	1	High	Low	
R/W									
FF40H	IOC03	IOC02	IOC01	IOC00	IOC03	0	Output	Input	P00–P03 I/O control register
					IOC02	0	Output	Input	
					IOC01	0	Output	Input	
					IOC00	0	Output	Input	
R/W									
FF41H	PUL03	PUL02	PUL01	PUL00	PUL03	1	On	Off	P00–P03 pull-up control register
					PUL02	1	On	Off	
					PUL01	1	On	Off	
					PUL00	1	On	Off	
R/W									
FF42H	P03	P02	P01	P00	P03	–*2	High	Low	P00–P03 I/O port data
					P02	–*2	High	Low	
					P01	–*2	High	Low	
					P00	–*2	High	Low	
R/W									

Table 4.1.1 (c) I/O memory map (FF44H–FF4DH)

Address	Register				Name	Init #1	1	0	Comment
	D3	D2	D1	D0					
FF44H	IOC13	IOC12	IOC11	IOC10	IOC13	0	Output	Input	P13 I/O control register General-purpose register when SIF (clock sync. slave) is selected
					IOC12	0	Output	Input	P12 I/O control register General-purpose register when SIF (clock sync.) is selected
	R/W				IOC11	0	Output	Input	P11 I/O control register (ESIF=0) General-purpose register when SIF is selected
	R/W				IOC10	0	Output	Input	P10 I/O control register (ESIF=0) General-purpose register when SIF is selected
FF45H	PUL13	PUL12	PUL11	PUL10	PUL13	1	On	Off	P13 pull-up control register General-purpose register when SIF (clock sync. slave) is selected
					PUL12	1	On	Off	P12 pull-up control register General-purpose register when SIF (clock sync. master) is selected
	R/W				PUL11	1	On	Off	SCLK (I) pull-up control register when SIF (clock sync. slave) is selected
	R/W				PUL10	1	On	Off	P11 pull-up control register (ESIF=0) General-purpose register when SIF is selected P10 pull-up control register (ESIF=0) SIN pull-up control register when SIF is selected
FF46H	P13 (XSRDY)	P12 (XSCLK)	P11 (SOUT)	P10 (SIN)	P13	– #2	High	Low	P13 I/O port data General-purpose register when SIF (clock sync. slave) is selected
					P12	– #2	High	Low	P12 I/O port data General-purpose register when SIF (clock sync.) is selected
	R/W				P11	– #2	High	Low	P11 I/O port data (ESIF=0) General-purpose register when SIF is selected
	R/W				P10	– #2	High	Low	P10 I/O port data (ESIF=0) General-purpose register when SIF is selected
FF48H	IOC23	IOC22	IOC21	IOC20	IOC23	0	Output	Input	P23 I/O control register (EXLCDC=0) General-purpose register when FR output is selected
					IOC22	0	Output	Input	P22 I/O control register (EXLCDC=0) General-purpose register when CL output is selected
	R/W				IOC21	0	Output	Input	P21 I/O control register
	R/W				IOC20	0	Output	Input	P20 I/O control register
FF49H	PUL23	PUL22	PUL21	PUL20	PUL23	1	On	Off	P23 pull-up control register (EXLCDC=0) General-purpose register when FR output is selected
					PUL22	1	On	Off	P22 pull-up control register (EXLCDC=0) General-purpose register when CL output is selected
	R/W				PUL21	1	On	Off	P21 pull-up control register
	R/W				PUL20	1	On	Off	P20 pull-up control register
FF4AH	P23 (FR)	P22 (CL)	P21	P20	P23	– #2	High	Low	P23 I/O port data (EXLCDC=0) General-purpose register when FR output is selected
					P22	– #2	High	Low	P22 I/O port data (EXLCDC=0) General-purpose register when CL output is selected
	R/W				P21	– #2	High	Low	P21 I/O port data
	R/W				P20	– #2	High	Low	P20 I/O port data
FF4CH	IOC33	IOC32	IOC31	IOC30	IOC33	0	Output	Input	P33 I/O control register General-purpose register when SIF (clock sync. slave) is selected
					IOC32	0	Output	Input	P32 I/O control register General-purpose register when SIF (clock sync.) is selected
	R/W				IOC31	0	Output	Input	P31 I/O control register (ESIFS=0) General-purpose register when SIF is selected
	R/W				IOC30	0	Output	Input	P30 I/O control register (ESIFS=0) General-purpose register when SIF is selected
FF4DH	PUL33	PUL32	PUL31	PUL30	PUL33	1	On	Off	P33 pull-up control register General-purpose register when SIF (clock sync. slave) is selected
					PUL32	1	On	Off	P32 pull-up control register General-purpose register when SIF (clock sync. master) is selected
	R/W				PUL31	1	On	Off	SCLK (I) pull-up control register when SIF (clock sync. slave) is selected
	R/W				PUL30	1	On	Off	P31 pull-up control register (ESIFS=0) General-purpose register when SIF is selected P30 pull-up control register (ESIFS=0) SIN pull-up control register when SIF is selected

Table 4.1.1 (d) I/O memory map (FF4EH–FF67H)

Address	Register				Name	Init *1	1	0	Comment
	D3	D2	D1	D0					
FF4EH	P33 (XSRDYS)	P32 (XSCLKS)	P31 (SOULTS)	P30 (SINS)	P33	–*2	High	Low	P33 I/O port data
					P32	–*2	High	Low	General-purpose register when SIF (clock sync. slave) is selected P32 I/O port data
	R/W				P31	–*2	High	Low	General-purpose register when SIF (clock sync.) is selected P31 I/O port data (ESIFS=0)
					P30	–*2	High	Low	General-purpose register when SIF is selected P30 I/O port data (ESIFS=0) General-purpose register when SIF is selected
FF58H	0	SMD1S	SMD0S	ESIFS	0 *3	–*2			Unused [SMD1S, 0S] 0 1
	R	R/W			SMD1S	0			Serial I/F (2) Mode Clk-sync. master Clk-sync. slave
					SMD0S	0			mode selection [SMD1S, 0S] 2 3
					ESIFS	0	SIF	I/O	Serial I/F (2) enable (P3x port function selection) Mode Async. 7-bit Async. 8-bit
FF59H	EPRS	PMDS	SCS1S	SCS0S	EPRS	0	Enable	Disable	Serial I/F (2) parity enable register
	R/W				PMDS	0	Odd	Even	Serial I/F (2) parity mode selection
					SCS1S	0			SIF (2) clock [SCS1S, 0S] 0 1 2 3
					SCS0S	0			source selection Mode 1200bps 600bps 2400bps PT
FF5AH	RXRTRGS	RXENS	TXRTRGS	TXENS	RXRTRGS	0	Run	Stop	Serial I/F (2) receive status (reading)
	R/W				RXENS	0	Enable	Disable	Serial I/F (2) receive trigger (writing)
					TXRTRGS	0	Run	Stop	Serial I/F (2) receive enable
					TXENS	0	Enable	Disable	Serial I/F (2) transmit status (reading) Serial I/F (2) transmit trigger (writing) Serial I/F (2) transmit enable
FF5BH	0	FERS	PERS	OERS	0 *3	–*2			Unused
	R	R/W			FERS	0	Error	No error	Serial I/F (2) framing error flag status (reading)
					PERS	0	Error	No error	Serial I/F (2) framing error flag reset (writing)
					OERS	0	Error	No error	Serial I/F (2) parity error flag status (reading) Serial I/F (2) parity error flag reset (writing) Serial I/F (2) overrun error flag status (reading) Serial I/F (2) overrun error flag reset (writing)
FF5CH	TRXD3S	TRXD2S	TRXD1S	TRXD0S	TRXD3S	–*2	High	Low	Serial I/F (2) transmit/receive data (low-order 4 bits) LSB
	R/W				TRXD2S	–*2	High	Low	
					TRXD1S	–*2	High	Low	
					TRXD0S	–*2	High	Low	
FF5DH	TRXD7S	TRXD6S	TRXD5S	TRXD4S	TRXD7S	–*2	High	Low	MSB Serial I/F (2) transmit/receive data (high-order 4 bits)
	R/W				TRXD6S	–*2	High	Low	
					TRXD5S	–*2	High	Low	
					TRXD4S	–*2	High	Low	
FF60H	LDUTY1	LDUTY0	Dummy	LPWR	LDUTY1	0			LCD drive duty [LDUTY1, 0] 0 1 2, 3 switch Duty 1/17 1/16 1/8 General-purpose register LCD power On/Off
	R/W				LDUTY0	0			
					Dummy	0			
LPWR	0	On	Off						
FF61H	EXLDCDC	ALOFF	ALON	LPAGE	EXLDCDC	0	Enable	Disable	Expanded LCD driver signal control
	R/W				ALOFF	1	All Off	Normal	LCD all Off control
					ALON	0	All On	Normal	LCD all On control
					LPAGE	0	F100-F15F	F000-F05F	Display memory area selection (when 1/8 duty is selected) General-purpose register when 1/16, 1/17 duty is selected
FF62H	LC3	LC2	LC1	LC0	LC3	–*2			LCD contrast adjustment [LC3–0] 0 – 15 Contrast Light – Dark
	R/W				LC2	–*2			
					LC1	–*2			
					LC0	–*2			
FF65H	0	0	BZOUT	XBZOUT	0 *3	–*2			Unused
	R				BZOUT	0	BZ	DC	Unused
					XBZOUT	0	XBZ	DC	R01 output selection (R01 should be fixed at "1"). R00 output selection (R00 should be fixed at "1").
FF66H	FSKON	0	RDET	CDET	FSKON	0	On	Off	FSK demodulator On/Off
	R/W				0 *3	–*2			Unused
					RDET	–*4	Ring	No Ring	Ring detection bit
CDET	0	Carrier	No Carrier	CDET	0			Carrier detection bit	
FF67H	0	0	RDETCP	CDETCP	0 *3	–*2			Unused
	R				0 *3	–*2			Unused
					RDETCP	0			RDET comparison register
CDETCP	0			CDETCP	0			CDET comparison register	

Table 4.1.1 (e) I/O memory map (FF6CH–FF7AH)

Address	Register				Name	Init #1	1	0	Comment
	D3	D2	D1	D0					
FF6CH	ENRTM	ENRST	ENON	BZE	ENRTM	0	1sec	0.5sec	Envelope releasing time selection
					ENRST*3	Reset	Reset	Invalid	Envelope reset (writing)
	R/W	W	R/W		ENON	0	On	Off	Envelope On/Off
					BZE	0	Enable	Disable	Buzzer output enable
FF6DH	0	BZSTP	BZSHT	SHTPW	0 *3	- *2			Unused
					BZSTP*3	0	Stop	Invalid	1-shot buzzer stop (writing)
					BZSHT	0	Trigger	Invalid	1-shot buzzer trigger (writing)
	R	W	R/W		SHTPW	0	Busy	Ready	1-shot buzzer status (reading)
FF6EH	0	BZFQ2	BZFQ1	BZFQ0	0 *3	- *2			Unused
					BZFQ2	0			Buzzer
					BZFQ1	0			frequency
	R	R/W			BZFQ0	0			selection
FF6FH	0	BDTY2	BDTY1	BDTY0	0 *3	- *2			Unused
					BDTY2	0			Buzzer signal duty ratio selection (refer to main manual)
					BDTY1	0			
	R	R/W			BDTY0	0			
FF70H	0	SMD1	SMD0	ESIF	0 *3	- *2			Unused
					SMD1	0			[SMD1, 0] 0 1
					SMD0	0			Serial I/F (1) Mode Clk-sync. master Clk-sync. slave
	R	R/W			ESIF	0	SIF	I/O	mode selection [SMD1, 0] 2 3 Mode Async. 7-bit Async. 8-bit
FF71H	EPR	PMD	SCS1	SCS0	EPR	0	Enable	Disable	Serial I/F (1) parity enable register
					PMD	0	Odd	Even	Serial I/F (1) parity mode selection
					SCS1	0			SIF (1) clock [SCS1, 0] 0 1 2 3
					SCS0	0			source selection Mode 1200bps 600bps 2400bps PT
FF72H	RXTRG	RXEN	TXTRG	TXEN	RXTRG	0	Run	Stop	Serial I/F (1) receive status (reading)
					RXEN	0	Trigger	-	Serial I/F (1) receive trigger (writing)
					TXTRG	0	Enable	Disable	Serial I/F (1) receive enable
					TXEN	0	Run	Stop	Serial I/F (1) transmit status (reading)
FF73H	0	FER	PER	OER	0 *3	- *2			Unused
					FER	0	Error	No error	Serial I/F (1) framing error flag status (reading)
					PER	0	Reset	-	Serial I/F (1) framing error flag reset (writing)
	R	R/W			OER	0	Error	No error	Serial I/F (1) overrun error flag status (reading)
FF74H	TRXD3	TRXD2	TRXD1	TRXD0	TRXD3	- *2	High	Low	Serial I/F (1) transmit/receive data (low-order 4 bits)
					TRXD2	- *2	High	Low	
					TRXD1	- *2	High	Low	
					TRXD0	- *2	High	Low	
FF75H	TRXD7	TRXD6	TRXD5	TRXD4	TRXD7	- *2	High	Low	Serial I/F (1) transmit/receive data (high-order 4 bits)
					TRXD6	- *2	High	Low	
					TRXD5	- *2	High	Low	
					TRXD4	- *2	High	Low	
FF76H	0	0	0	SIFTM	0 *3	- *2			Unused
					0 *3	- *2			Unused
					0 *3	- *2			Unused
					SIFTM	0			Serial I/F test mode (disabled. Do not change.)
FF78H	0	0	TMRST	TMRUN	0 *3	- *2			Unused
					0 *3	- *2			Unused
					TMRST*3	Reset	Reset	Invalid	Clock timer reset (writing)
					TMRUN	0	Run	Stop	Clock timer Run/Stop
FF79H	TM3	TM2	TM1	TM0	TM3	0			Clock timer data (16 Hz)
					TM2	0			Clock timer data (32 Hz)
					TM1	0			Clock timer data (64 Hz)
					TM0	0			Clock timer data (128 Hz)
FF7AH	TM7	TM6	TM5	TM4	TM7	0			Clock timer data (1 Hz)
					TM6	0			Clock timer data (2 Hz)
					TM5	0			Clock timer data (4 Hz)
					TM4	0			Clock timer data (8 Hz)

Table 4.1.1 (f) I/O memory map (FF7CH–FFCBH)

Address	Register				Name	Init *1	1	0	Comment
	D3	D2	D1	D0					
FF7CH	0	0	SWRST	SWRUN	0 *3 0 *3	- *2 - *2			Unused Unused
	R		W	R/W	SWRST*3 SWRUN	Reset 0	Reset Run	Invalid Stop	Stopwatch timer reset (writing) Stopwatch timer Run/Stop
FF7DH	SWD3	SWD2	SWD1	SWD0	SWD3 SWD2 SWD1 SWD0	0 0 0 0			Stopwatch timer data BCD (1/100 sec)
	R								
FF7EH	SWD7	SWD6	SWD5	SWD4	SWD7 SWD6 SWD5 SWD4	0 0 0 0			Stopwatch timer data BCD (1/10 sec)
	R								
FFC0H	0	EVCNT	FCSEL	PLPOL	0 *3 EVCNT FCSEL PLPOL	- *2 0 0 0			Unused Timer 0 counter mode selection Timer 0 function selection (for event counter mode) Timer 0 pulse polarity selection (for event counter mode)
	R	R/W					Event ct. With NR ↓	Timer No NR ↓	
FFC1H	CHSEL	PTOUT	CKSEL1	CKSEL0	CHSEL PTOUT CKSEL1 CKSEL0	0 0 0 0	Timer1 On	Timer0 Off	TOUT output channel selection TOUT output control Prescaler 1 source clock selection Prescaler 0 source clock selection
	R/W						OSC3 OSC3	OSC1 OSC1	
FFC2H	PTPS01	PTPS00	PTRST0	PTRUN0	PTPS01 PTPS00 PTRST0*3 PTRUN0	0 0 - *2 0			Prescaler 0 [PTPS01, 00] 0 1 2 3 Division ratio 1/1 1/4 1/32 1/256 Timer 0 reset (reload) Timer 0 Run/Stop
	R/W		W	R/W			Reset Run	Invalid Stop	
FFC3H	PTPS11	PTPS10	PTRST1	PTRUN1	PTPS11 PTPS10 PTRST1*3 PTRUN1	0 0 - *2 0			Prescaler 1 [PTPS11, 10] 0 1 2 3 Division ratio 1/1 1/4 1/32 1/256 Timer 1 reset (reload) Timer 1 Run/Stop
	R/W		W	R/W			Reset Run	Invalid Stop	
FFC4H	RLD03	RLD02	RLD01	RLD00	RLD03 RLD02 RLD01 RLD00	0 0 0 0			MSB Programmable timer 0 reload data (low-order 4 bits) LSB
	R/W								
FFC5H	RLD07	RLD06	RLD05	RLD04	RLD07 RLD06 RLD05 RLD04	0 0 0 0			MSB Programmable timer 0 reload data (high-order 4 bits) LSB
	R/W								
FFC6H	RLD13	RLD12	RLD11	RLD10	RLD13 RLD12 RLD11 RLD10	0 0 0 0			MSB Programmable timer 1 reload data (low-order 4 bits) LSB
	R/W								
FFC7H	RLD17	RLD16	RLD15	RLD14	RLD17 RLD16 RLD15 RLD14	0 0 0 0			MSB Programmable timer 1 reload data (high-order 4 bits) LSB
	R/W								
FFC8H	PTD03	PTD02	PTD01	PTD00	PTD03 PTD02 PTD01 PTD00	0 0 0 0			MSB Programmable timer 0 data (low-order 4 bits) LSB
	R								
FFC9H	PTD07	PTD06	PTD05	PTD04	PTD07 PTD06 PTD05 PTD04	0 0 0 0			MSB Programmable timer 0 data (high-order 4 bits) LSB
	R								
FFCAH	PTD13	PTD12	PTD11	PTD10	PTD13 PTD12 PTD11 PTD10	0 0 0 0			MSB Programmable timer 1 data (low-order 4 bits) LSB
	R								
FFCBH	PTD17	PTD16	PTD15	PTD14	PTD17 PTD16 PTD15 PTD14	0 0 0 0			MSB Programmable timer 1 data (high-order 4 bits) LSB
	R								

Table 4.1.1 (h) I/O memory map (FFF8H–FFFAH)

Address	Register				Name	Init *1	1	0	Comment
	D3	D2	D1	D0					
FFF8H	0	ISERS	ISTRS	ISRCS	0 *3	- *2	(R)	(R)	Unused
	R	R/W			ISERS	0	Yes	No	Interrupt factor flag (Serial I/F (2) error)
					ISTRS	0	(W)	(W)	Interrupt factor flag (Serial I/F (2) transmit completion)
					ISRCS	0	Reset	Invalid	Interrupt factor flag (Serial I/F (2) receive completion)
FFF9H	0	0	0	ID	0 *3	- *2	(R)	(R)	Unused
	R	R/W			0 *3	- *2	Yes	No	Unused
					0 *3	- *2	(W)	(W)	Unused
					ID	0	Reset	Invalid	Interrupt factor flag (Dialer)
FFFAH	0	0	IRDET	ICDET	0 *3	- *2	(R)	(R)	Unused
	R	R/W			0 *3	- *2	Yes	No	Unused
					IRDET	0	(W)	(W)	Interrupt factor flag (FSK demodulator ring detection)
					ICDET	0	Reset	Invalid	Interrupt factor flag (FSK demodulator carrier detection)

4.2 Watchdog Timer

4.2.1 Configuration of watchdog timer

The S1C63558 has a built-in watchdog timer that operates with a 256 Hz divided clock from the OSC1 as the source clock. The watchdog timer starts operating after initial reset, however, it can be stopped by the software. The watchdog timer must be reset cyclically by the software while it operates. If the watchdog timer is not reset in at least 3–4 seconds, it generates a non-maskable interrupt (NMI) to the CPU.

Figure 4.2.1.1 is the block diagram of the watchdog timer.

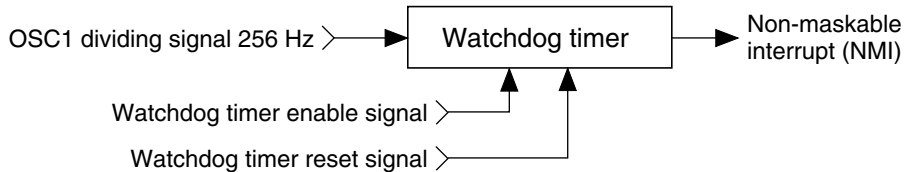

Fig. 4.2.1.1 Watchdog timer block diagram

The watchdog timer contains a 10-bit binary counter, and generates the non-maskable interrupt when the last stage of the counter (0.25 Hz) overflows.

Watchdog timer reset processing in the program's main routine enables detection of program overrun, such as when the main routine's watchdog timer processing is bypassed. Ordinarily this routine is incorporated where periodic processing takes place, just as for the timer interrupt routine.

The watchdog timer operates in the HALT mode. If a HALT status continues for 3–4 seconds, the non-maskable interrupt releases the HALT status.

4.2.2 Interrupt function

If the watchdog timer is not reset periodically, the non-maskable interrupt (NMI) is generated to the core CPU. Since this interrupt cannot be masked, it is accepted even in the interrupt disable status (I flag = "0"). However, it is not accepted when the CPU is in the interrupt mask state until SP1 and SP2 are set as a pair, such as after initial reset or during re-setting the stack pointer. The interrupt vector of NMI is assigned to 0100H in the program memory.

4.2.3 I/O memory of watchdog timer

Table 4.2.3.1 shows the I/O address and control bits for the watchdog timer.

Table 4.2.3.1 Control bits of watchdog timer

Address	Register								Comment
	D3	D2	D1	D0	Name	Init *1	1	0	
FF07H	0	0	WDEN	WDRST	0 *3	- *2			Unused
					0 *3	- *2			Unused
	R		R/W	W	WDEN	1	Enable	Disable	Watchdog timer enable
				WDRST*3	Reset	Reset	Invalid		Watchdog timer reset (writing)

*1 Initial value at initial reset

*2 Not set in the circuit

*3 Constantly "0" when being read

WDEN: Watchdog timer enable register (FF07H•D1)

Selects whether the watchdog timer is used (enabled) or not (disabled).

- When "1" is written: Enabled
- When "0" is written: Disabled
- Reading: Valid

When "1" is written to the WDEN register, the watchdog timer starts count operation. When "0" is written, the watchdog timer does not count and does not generate the interrupt (NMI).

At initial reset, this register is set to "1".

WDRST: Watchdog timer reset (FF07H•D0)

Resets the watchdog timer.

- When "1" is written: Watchdog timer is reset
- When "0" is written: No operation
- Reading: Always "0"

When "1" is written to WDRST, the watchdog timer is reset and restarts immediately after that. When "0" is written, no operation results.

This bit is dedicated for writing, and is always "0" for reading.

4.2.4 Programming notes

- (1) When the watchdog timer is being used, the software must reset it within 3-second cycles.
- (2) Because the watchdog timer is set in operation state by initial reset, set the watchdog timer to disabled state (not used) before generating an interrupt (NMI) if it is not used.

4.3 Oscillation Circuit

4.3.1 Configuration of oscillation circuit

The S1C63558 has two oscillation circuits (OSC1 and OSC3). OSC1 is a crystal oscillation circuit that supplies the operating clock to the CPU and peripheral circuits. OSC3 is a ceramic oscillation circuit. When processing with the S1C63558 requires high-speed operation, the CPU operating clock can be switched from OSC1 to OSC3 by the software. Figure 4.3.1.1 is the block diagram of this oscillation system.

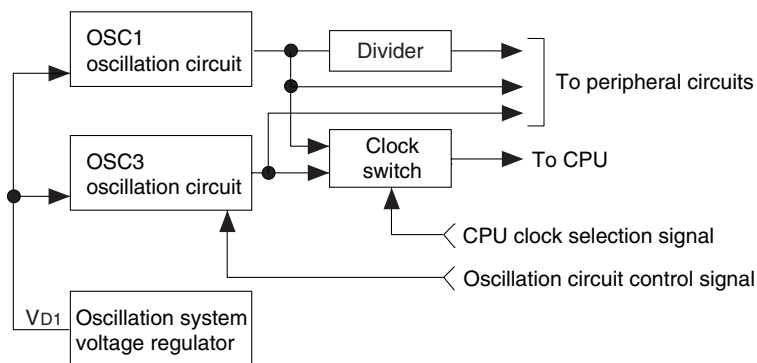

Fig. 4.3.1.1 Oscillation system block diagram

4.3.2 OSC1 oscillation circuit

The OSC1 crystal oscillation circuit generates the main clock for the CPU and the peripheral circuits. The oscillation frequency is 32.768 kHz (Typ.). Figure 4.3.2.1 is the block diagram of the OSC1 oscillation circuit.

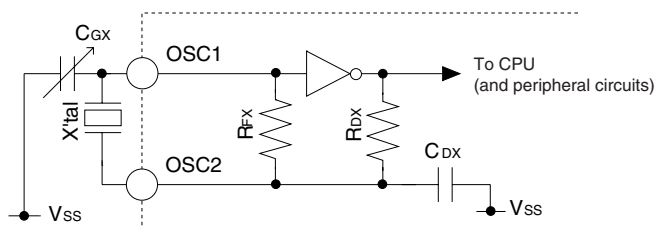

Fig. 4.3.2.1 OSC1 oscillation circuit

As shown in Figure 4.3.2.1, the crystal oscillation circuit can be configured simply by connecting the crystal oscillator (X'tal) of 32.768 kHz (Typ.) between the OSC1 and OSC2 terminals and the trimmer capacitor (CGX) between the OSC1 and Vss terminals.

4.3.3 OSC3 oscillation circuit

The S1C63558 has built-in the OSC3 oscillation circuit that generates the CPU's sub-clock (3.58 MHz) for high speed operation and the source clock for peripheral circuits needing a high speed clock (programmable timer, FOUT output). To configure a ceramic oscillation circuit, a ceramic oscillator and two capacitors (gate and drain capacitance) are required. Figure 4.3.3.1 is the block diagram of the OSC3 oscillation circuit.

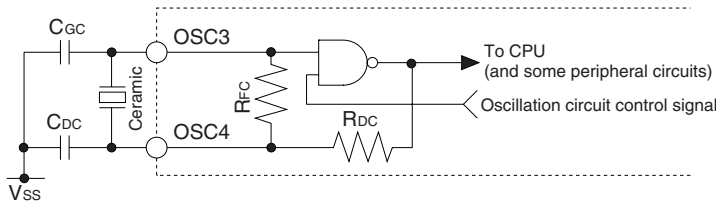

Fig. 4.3.3.1 OSC3 oscillation circuit

As shown in Figure 4.3.3.1, the ceramic oscillation circuit can be configured by connecting the ceramic oscillator (3.58 MHz) between the OSC3 and OSC4 terminals, capacitor CGC between the OSC3 and OSC4 terminals, and capacitor CDC between the OSC4 and VSS terminals. For both CGC and CDC, connect capacitors that are about 30 pF. To reduce current consumption of the OSC3 oscillation circuit, oscillation can be stopped by the software (OSCC register).

4.3.4 Switching the CPU operating clock

The CPU system clock is switched to OSC1 or OSC3 by the software (CLKCHG register). When OSC3 is to be used as the CPU system clock, first turn the OSC3 oscillation ON and switch the clock after waiting 5 msec or more for oscillation stabilization. When switching from OSC3 to OSC1, turn the OSC3 oscillation circuit OFF after switching the clock.

OSC1 → OSC3

1. Set OSCC to "1" (OSC3 oscillation ON).
2. Maintain 5 msec or more.
3. Set CLKCHG to "1" (OSC1 → OSC3).

OSC3 → OSC1

1. Set CLKCHG to "0" (OSC3 → OSC1).
2. Set OSCC to "0" (OSC3 oscillation OFF).

Note: When switching the clock form OSC3 to OSC1, use a separate instruction for switching the OSC3 oscillation OFF. An error in the CPU operation can result if this processing is performed at the same time by the one instruction.

4.3.5 Clock frequency and instruction execution time

Table 4.3.5.1 shows the instruction execution time according to each frequency of the system clock.

Table 4.3.5.1 Clock frequency and instruction execution time

Clock frequency	Instruction execution time (μsec)		
	1-cycle instruction	2-cycle instruction	3-cycle instruction
OSC1: 32.768 kHz	61	122	183
OSC3: 3.58 MHz	0.56	1.12	1.68

4.3.6 I/O memory of oscillation circuit

Table 4.3.6.1 shows the I/O address and the control bits for the oscillation circuit.

Table 4.3.6.1 Control bits of oscillation circuit

Address	Register								Comment
	D3	D2	D1	D0	Name	Init *1	1	0	
FF00H	CLKCHG	OSCC	0	Dummy	CLKCHG	0	OSC3	OSC1	CPU clock switch
					OSCC	0	On	Off	OSC3 oscillation On/Off
					0 *3	- *2			Unused
					Dummy	0			General-purpose register
	R/W		R	R/W					

*1 Initial value at initial reset

*2 Not set in the circuit

*3 Constantly "0" when being read

OSCC: OSC3 oscillation control register (FF00H•D2)

Controls oscillation ON/OFF for the OSC3 oscillation circuit.

When "1" is written: OSC3 oscillation ON

When "0" is written: OSC3 oscillation OFF

Reading: Valid

When it is necessary to operate the CPU at high speed, set OSCC to "1". At other times, set it to "0" to reduce current consumption.

At initial reset, this register is set to "0".

CLKCHG: CPU system clock switching register (FF00H•D3)

The CPU's operation clock is selected with this register.

When "1" is written: OSC3 clock is selected

When "0" is written: OSC1 clock is selected

Reading: Valid

When the CPU clock is to be OSC3, set CLKCHG to "1"; for OSC1, set CLKCHG to "0".

After turning the OSC3 oscillation ON (OSCC = "1"), switching of the clock should be done after waiting 5 msec or more.

At initial reset, this register is set to "0".

4.3.7 Programming notes

- (1) It takes at least 5 msec from the time the OSC3 oscillation circuit goes ON until the oscillation stabilizes. Consequently, when switching the CPU operation clock from OSC1 to OSC3, do this after a minimum of 5 msec have elapsed since the OSC3 oscillation went ON.
Further, the oscillation stabilization time varies depending on the external oscillator characteristics and conditions of use, so allow ample margin when setting the wait time.
- (2) When switching the clock form OSC3 to OSC1, use a separate instruction for switching the OSC3 oscillation OFF. An error in the CPU operation can result if this processing is performed at the same time by the one instruction.
- (3) The internal operating voltage of VD1 is fixed at 2.2 V. So it is not necessary to control the operating voltage regardless of the operating clock selected.

4.4 Input Ports (K00–K03 and K10–K13)

4.4.1 Configuration of input ports

The S1C63558 has eight bits general-purpose input ports. Each of the input port terminals (K00–K03, K10–K13) provides internal pull-up resistor. Pull-up resistor can be selected for each bit with the mask option.

Figure 4.4.1.1 shows the configuration of input port.

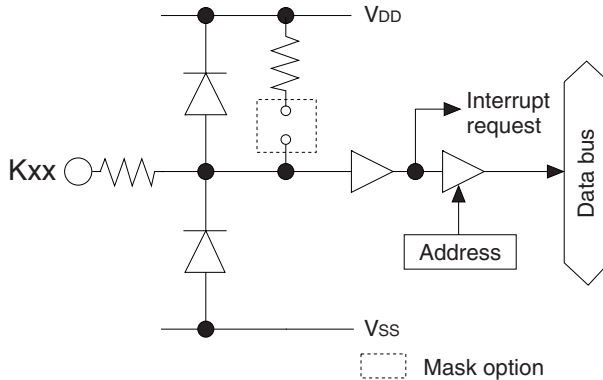

Fig. 4.4.1.1 Configuration of input port

Selection of "With pull-up resistor" with the mask option suits input from the push switch, key matrix, and so forth. When "Gate direct" is selected, the port can be used for slide switch input and interfacing with other LSIs.

4.4.2 Interrupt function

All eight bits of the input ports (K00–K03, K10–K13) provide the interrupt function. The conditions for issuing an interrupt can be set by the software. Further, whether to mask the interrupt function can be selected by the software.

Figure 4.4.2.1 shows the configuration of K00–K03 (K10–K13) interrupt circuit.

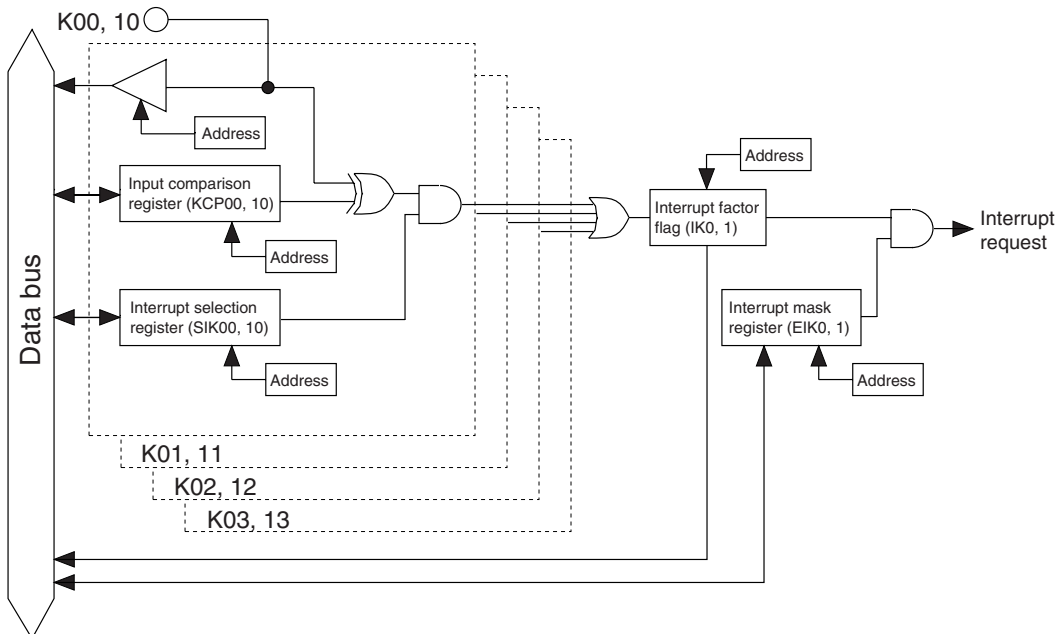

Fig. 4.4.2.1 Input interrupt circuit configuration

The interrupt selection register (SIK) and input comparison register (KCP) are individually set for the input ports K00–K03 and K10–K13, and can specify the terminals for generating interrupt and interrupt timing.

The interrupt selection registers (SIK00–SIK03, SIK10–SIK13) select what input of K00–K03 and K10–K13 to use for the interrupt. Writing "1" into an interrupt selection register incorporates that input port into the interrupt generation conditions. The changing the input port where the interrupt selection register has been set to "0" does not affect the generation of the interrupt.

The input interrupt timing can select that the interrupt be generated at the rising edge of the input or that it be generated at the falling edge according to the set value of the input comparison registers (KCP00–KCP03, KCP10–KCP13).

By setting these two conditions, the interrupt for K00–K03 or K10–K13 is generated when input ports in which an interrupt has been enabled by the input selection registers and the contents of the input comparison registers have been changed from matching to no matching.

The interrupt mask registers (EIK0, EIK1) enable the interrupt mask to be selected for K00–K03 and K10–K13.

When the interrupt is generated, the interrupt factor flag (IK0, IK1) is set to "1".

Figure 4.4.2.2 shows an example of an interrupt for K00–K03.

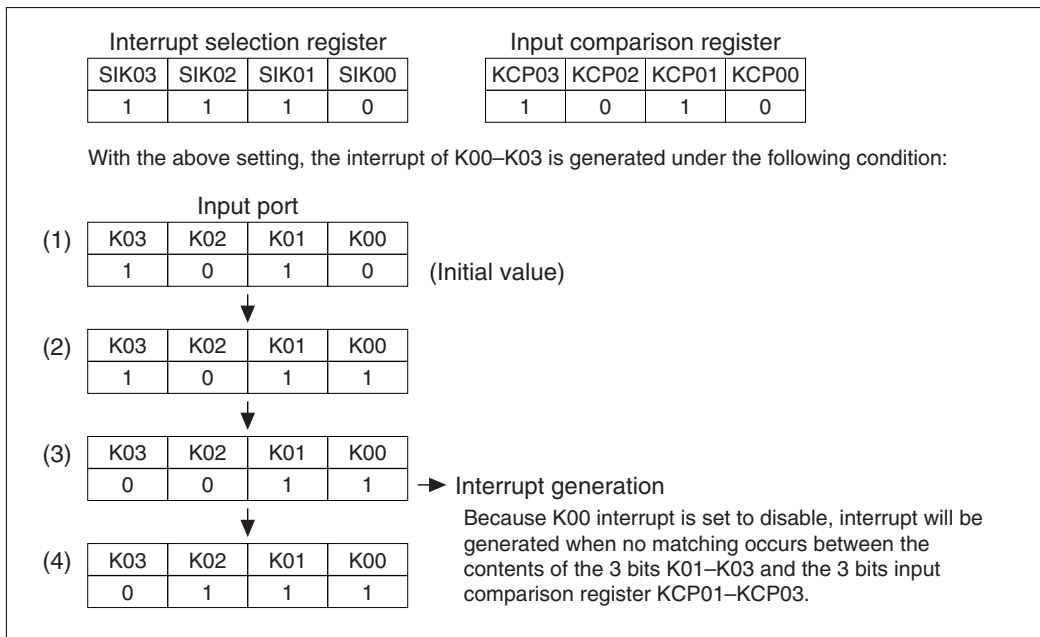

Fig. 4.4.2.2 Example of interrupt of K00–K03

K00 interrupt is disabled by the interrupt selection register (SIK00), so that an interrupt does not occur at (2). At (3), K03 changes to "0"; the data of the terminals that are interrupt enabled no longer match the data of the input comparison registers, so that interrupt occurs. As already explained, the condition for the interrupt to occur is the change in the port data and contents of the input comparison registers from matching to no matching. Hence, in (4), when the no matching status changes to another no matching status, an interrupt does not occur. Further, terminals that have been masked for interrupt do not affect the conditions for interrupt generation.

4.4.3 Mask option

Internal pull-up resistor can be selected for each of the eight bits of the input ports (K00–K03, K10–K13) with the input port mask option.

When "Gate direct" is selected, take care that the floating status does not occur for the input. Select "With pull-up resistor" for input ports that are not being used.

4.4.4 I/O memory of input ports

Table 4.4.4.1 shows the I/O addresses and the control bits for the input ports.

Table 4.4.4.1 Control bits of input ports

Address	Register				Name	Init *1	1	0	Comment
	D3	D2	D1	D0					
FF20H	SIK03	SIK02	SIK01	SIK00	SIK03	0	Enable	Disable	K00–K03 interrupt selection register
					SIK02	0	Enable	Disable	
					SIK01	0	Enable	Disable	
					SIK00	0	Enable	Disable	
R/W									
FF21H	K03	K02	K01	K00	K03	–*2	High	Low	K00–K03 input port data
					K02	–*2	High	Low	
					K01	–*2	High	Low	
					K00	–*2	High	Low	
R									
FF22H	KCP03	KCP02	KCP01	KCP00	KCP03	1	↓	↑	K00–K03 input comparison register
					KCP02	1	↓	↑	
					KCP01	1	↓	↑	
					KCP00	1	↓	↑	
R/W									
FF24H	SIK13	SIK12	SIK11	SIK10	SIK13	0	Enable	Disable	K10–K13 interrupt selection register
					SIK12	0	Enable	Disable	
					SIK11	0	Enable	Disable	
					SIK10	0	Enable	Disable	
R/W									
FF25H	K13	K12	K11	K10	K13	–*2	High	Low	K10–K13 input port data
					K12	–*2	High	Low	
					K11	–*2	High	Low	
					K10	–*2	High	Low	
R									
FF26H	KCP13	KCP12	KCP11	KCP10	KCP13	1	↓	↑	K10–K13 input comparison register
					KCP12	1	↓	↑	
					KCP11	1	↓	↑	
					KCP10	1	↓	↑	
R/W									
FFE4H	0	0	0	EIK0	0 *3	–*2			Unused
					0 *3	–*2			Unused
					0 *3	–*2			Unused
					EIK0	0	Enable	Mask	Interrupt mask register (K00–K03)
R/W									
FFE5H	0	0	0	EIK1	0 *3	–*2			Unused
					0 *3	–*2			Unused
					0 *3	–*2			Unused
					EIK1	0	Enable	Mask	Interrupt mask register (K10–K13)
R/W									
FFF4H	0	0	0	IK0	0 *3	–*2	(R)	(R)	Unused
					0 *3	–*2	Yes	No	Unused
					0 *3	–*2	(W)	(W)	Unused
					IK0	0	Reset	Invalid	Interrupt factor flag (K00–K03)
R/W									
FFF5H	0	0	0	IK1	0 *3	–*2	(R)	(R)	Unused
					0 *3	–*2	Yes	No	Unused
					0 *3	–*2	(W)	(W)	Unused
					IK1	0	Reset	Invalid	Interrupt factor flag (K10–K13)
R/W									

*1 Initial value at initial reset

*2 Not set in the circuit

*3 Constantly "0" when being read

K00–K03: K0 port input port data (FF21H)

K10–K13: K1 port input port data (FF25H)

Input data of the input port terminals can be read with these registers.

When "1" is read: High level

When "0" is read: Low level

Writing: Invalid

The reading is "1" when the terminal voltage of the eight bits of the input ports (K00–K03, K10–K13) goes high (VDD), and "0" when the voltage goes low (VSS).

These bits are dedicated for reading, so writing cannot be done.

SIK00–SIK03: K0 port interrupt selection register (FF20H)**SIK10–SIK13: K1 port interrupt selection register (FF24H)**

Selects the ports to be used for the K00–K03 and K10–K13 input interrupts.

When "1" is written: Enable

When "0" is written: Disable

Reading: Valid

Enables the interrupt for the input ports (K00–K03, K10–K13) for which "1" has been written into the interrupt selection registers (SIK00–SIK03, SIK10–SIK13). The input port set for "0" does not affect the interrupt generation condition.

At initial reset, these registers are set to "0".

KCP00–KCP03: K0 port input comparison register (FF22H)**KCP10–KCP13: K1 port input comparison register (FF26H)**

Interrupt conditions for terminals K00–K03 and K10–K13 can be set with these registers.

When "1" is written: Falling edge

When "0" is written: Rising edge

Reading: Valid

The interrupt conditions can be set for the rising or falling edge of input for each of the eight bits (K00–K03 and K10–K13), through the input comparison registers (KCP00–KCP03 and KCP10–KCP13).

For KCP00–KCP03, a comparison is done only with the ports that are enabled by the interrupt among K00–K03 by means of the SIK00–SIK03 registers. For KCP10–KCP13, a comparison is done only with the ports that are enabled by the interrupt among K10–K13 by means of the SIK10–SIK13 registers.

At initial reset, these registers are set to "0".

EIK0: K0 input interrupt mask register (FFE4H•D0)**EIK1: K1 input interrupt mask register (FFE5H•D0)**

Masking the interrupt of the input port can be selected with these registers.

When "1" is written: Enable

When "0" is written: Mask

Reading: Valid

With these registers, masking of the input port interrupt can be selected for each of the two systems (K00–K03, K10–K13).

At initial reset, these registers are set to "0".

IK0: K0 input interrupt factor flag (FFF4H•D0)**IK1: K1 input interrupt factor flag (FFF5H•D0)**

These flags indicate the occurrence of input interrupt.

When "1" is read: Interrupt has occurred

When "0" is read: Interrupt has not occurred

When "1" is written: Flag is reset

When "0" is written: Invalid

The interrupt factor flags IK0 and IK1 are associated with K00–K03 and K10–K13, respectively. From the status of these flags, the software can decide whether an input interrupt has occurred.

The interrupt factor flag is set to "1" when the interrupt condition is established regardless of the interrupt mask register setting. However, the interrupt does not occur to the CPU when the interrupt is masked.

These flags are reset to "0" by writing "1" to them.

After an interrupt occurs, the same interrupt will occur again if the interrupt enabled state (I flag = "1") is set or the RETI instruction is executed unless the interrupt factor flag is reset. Therefore, be sure to reset (write "1" to) the interrupt factor flag in the interrupt service routine before shifting to the interrupt enabled state.

At initial reset, these flags are set to "0".

4.4.5 Programming notes

- (1) When input ports are changed from low to high by pull-up resistors, the rise of the waveform is delayed on account of the time constant of the pull-up resistor and input gate capacitance. Hence, when fetching input ports, set an appropriate waiting time.

Particular care needs to be taken of the key scan during key matrix configuration.

Make this waiting time the amount of time or more calculated by the following expression.

$$10 \times C \times R$$

C: terminal capacitance 5 pF + parasitic capacitance ? pF

R: pull-up resistance 330 kΩ

- (2) The K13 terminal functions as the clock input terminal for the programmable timer, and the input signal is shared with the input port and the programmable timer. Therefore, when the K13 terminal is set to the clock input terminal for the programmable timer, take care of the interrupt setting.
- (3) After an interrupt occurs, the same interrupt will occur again if the interrupt enabled state (I flag = "1") is set or the RETI instruction is executed unless the interrupt factor flag is reset. Therefore, be sure to reset (write "1" to) the interrupt factor flag in the interrupt service routine before shifting to the interrupt enabled state.

4.5 Output Ports (R00–R03, R10–R13 and R20–R23)

4.5.1 Configuration of output ports

The S1C63558 has 12 bits general output ports.

Output specifications of the output ports can be selected individually with the mask option. Two kinds of output specifications are available: complementary output and N-channel open drain output.

Figure 4.5.1.1 shows the configuration of the output port.

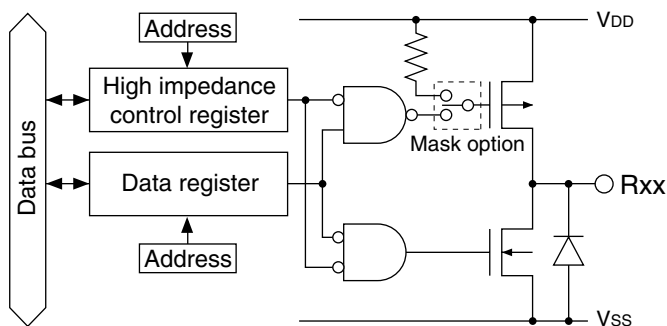

Fig. 4.5.1.1 Configuration of output port

The R00 to R03 output terminals are shared with the buzzer/clock outputs (XBZ, BZ, TOUT, FOUT). The R10 to R13 output terminals are shared with the tone/pulse dialer outputs (XTMUTE, XRMUTE, HDO, HFO). These functions are selected by the software.

At initial reset, these are all set to the general purpose output port.

Table 4.5.1.1 shows the setting of the output terminals by function selection.

Table 4.5.1.1 Function setting of output terminals

Terminal name	Terminal status at initial reset	Special output							
		FOUT	TOUT	BZ	XBZ	HFO	HDO	XRMUTE	XTMUTE
R00	R00 (HIGH output)	R00	R00	R00	XBZ	R00	R00	R00	R00
R01	R01 (HIGH output)	R01	R01	BZ	R01	R01	R01	R01	R01
R02	R02 (HIGH output)	R02	TOUT	R02	R02	R02	R02	R02	R02
R03	R03 (HIGH output)	FOUT	R03	R03	R03	R03	R03	R03	R03
R10	R10 (HIGH output)	R10	R10	R10	R10	R10	R10	R10	XTMUTE
R11	R11 (HIGH output)	R11	R11	R11	R11	R11	R11	XRMUTE	R11
R12	R12 (HIGH output)	R12	R12	R12	R12	R12	HDO	R12	R12
R13	R13 (HIGH output)	R13	R13	R13	R13	HFO	R13	R13	R13
R20–R23	R20–R23 (HIGH output)	R20–R23	R20–R23	R20–R23	R20–R23	R20–R23	R20–R23	R20–R23	R20–R23

When using the output port as the special output port, the data register must be fixed at "1" and the high impedance control register must be fixed at "0" (data output).

4.5.2 Mask option

Output specifications of the output ports can be selected with the mask option.

Either complementary output or N-channel open drain output can be selected individually (1-bit units).

However, when N-channel open drain output is selected, do not apply a voltage exceeding the power supply voltage to the output port.

4.5.3 High impedance control

The terminal output status of the output ports can be set to a high impedance status. This control is done using the high impedance control register (RxxHIZ) corresponding to each output port (Rxx). When "1" is written to the high impedance control register, the corresponding output port terminal goes into high impedance status. When "0" is written, the port outputs a signal according to the data register.

4.5.4 Special output

In addition to the regular DC output, special output can be selected for the output ports R00–R03 and R10–R13 as shown in Table 4.5.4.1 with the software.

Figure 4.5.4.1 shows the configuration of the R00–R03 and R10–R13 output ports.

Table 4.5.4.1 Special output

Terminal	Special output	Output control register
R13	HFO	CHFO
R12	HDO	CHDO
R11	XRMUTE	CRMO
R10	XTMUTE	CTMO
R03	FOUT	FOUTE
R02	TOUT	PTOUT
R01	BZ	BZOUT
R00	XBZ	XBZOUT

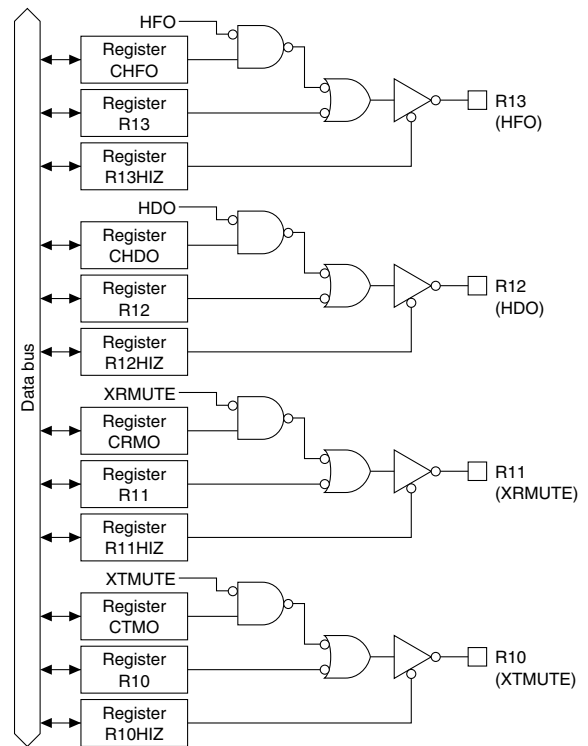
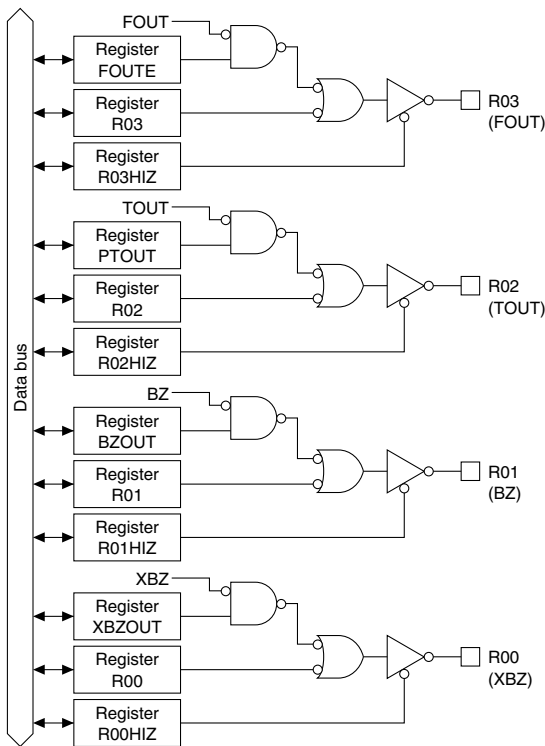

Fig. 4.5.4.1(a) Configuration of R00–R03 output ports

Fig. 4.5.4.1(b) Configuration of R10–R13 output ports

At initial reset, the output port data register is set to "1" and the high impedance control register is set to "0". Consequently, the output terminal goes high (VDD).

When using the output port (R00–R03, R10–R13) as the special output port, fix the data register (R00–R03, R10–R13) at "1" and the high impedance control register (R00HIZ–R03HIZ, R10HIZ–R13HIZ) at "0" (data output). The respective signal should be turned ON and OFF using the special output control register.

- Note:
- Be aware that the output terminal is fixed at a low (V_{SS}) level the same as the DC output if "0" is written to the R00–R03 and R10–R13 registers when the special output has been selected.
 - Be aware that the output terminal shifts into high impedance status when "1" is written to the high impedance control register (R00HIZ–R03HIZ, R10HIZ–R13HIZ).
 - A hazard may occur when the special output signal is turned ON and OFF by software.

• XBZ (R00)

The R00 terminal can output an XBZ signal.

The XBZ signal is the buzzer inverted signal that is output from the sound generator, and can be used to drive a piezoelectric buzzer with the BZ signal.

To output the XBZ signal, set the R00 port as the XBZ output by writing "1" to the XBZOUT register and fix the R00 register at "1" and the R00HIZ register at "0". Use the BZE register for controlling (ON/OFF) the XBZ signal output.

Refer to Section 4.12, "Sound Generator" for details of the buzzer signal and controlling method.

• BZ (R01)

The R01 terminal can output a BZ signal.

The BZ signal is the buzzer signal that is output from the sound generator.

To output the BZ signal, set the R01 port as the BZ output by writing "1" to the BZOUT register and fix the R01 register at "1" and the R01HIZ register at "0". Use the BZE register for controlling (ON/OFF) the BZ signal output.

Refer to Section 4.12, "Sound Generator" for details of the buzzer signal and controlling method.

• TOUT (R02)

The R02 terminal can output a TOUT signal.

The TOUT signal is the clock that is output from the programmable timer, and can be used to provide a clock signal to an external device.

To output the TOUT signal, fix the R02 register at "1" and the R02HIZ register at "0", and turn the signal ON and OFF using the PTOUT register. It is, however, necessary to control the programmable timer.

Refer to Section 4.10, "Programmable Timer" for details of the TOUT signal and controlling method.

• FOUT (R03)

The R03 terminal can output an FOUT signal.

The FOUT signal is a clock (f_{OSC1} or f_{OSC3}) that is output from the oscillation circuit or a clock that the f_{OSC1} clock has divided in the internal circuit, and can be used to provide a clock signal to an external device.

To output the FOUT signal, fix the R03 register at "1" and the R03HIZ register at "0", and turn the signal ON and OFF using the FOUTE register.

The frequency of the output clock may be selected from among 4 types shown in Table 4.5.4.2 by setting the FOFQ0 and FOFQ1 registers.

Table 4.5.4.2 FOUT clock frequency

FOFQ1	FOFQ0	Clock frequency
1	1	f_{OSC3}
1	0	f_{OSC1}
0	1	$f_{OSC1} \times 1/8$
0	0	$f_{OSC1} \times 1/64$

f_{OSC1} : Clock that is output from the OSC1 oscillation circuit

f_{OSC3} : Clock that is output from the OSC3 oscillation circuit

When f_{OSC3} is selected for the FOUT signal frequency, it is necessary to control the OSC3 oscillation circuit before output.

Refer to Section 4.3, "Oscillation Circuit", for the control and notes.

Figure 4.5.4.2 shows the output waveform of the FOUT signal.

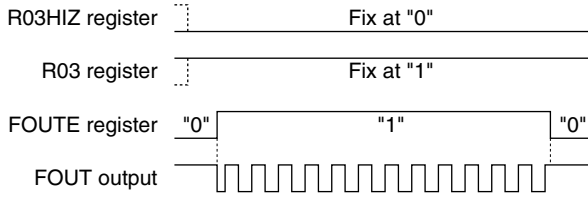

Fig. 4.5.4.2 Output waveform of FOUT signal

• **XTMUTE (R10)**

The R10 terminal can output an XTMUTE signal.

The XTMUTE signal is the transmitter mute signal used for the telephone function.

To output the XTMUTE signal, set the R10 port as the XTMUTE output by writing "1" to the CTMO register and fix the R10 register at "1" and the R10HIZ register at "0". Use the CTMUTE register for controlling the XTMUTE signal output.

Refer to Section 4.14, "Telephone Function" for details of the signal and controlling method.

• **XRMUTE (R11)**

The R11 terminal can output an XRMUTE signal.

The XRMUTE signal is the receiver mute signal used for the telephone function.

To output the XRMUTE signal, set the R11 port as the XRMUTE output by writing "1" to the CRMO register and fix the R11 register at "1" and the R11HIZ register at "0". Use the CRMUTE register for controlling the XRMUTE signal output.

Refer to Section 4.14, "Telephone Function" for details of the signal and controlling method.

• **HDO (R12)**

The R12 terminal can output a HDO signal.

The HDO signal is the hold line signal used for the telephone function.

To output the HDO signal, set the R12 port as the HDO output by writing "1" to the CHDO register and fix the R12 register at "1" and the R12HIZ register at "0". Use the HOLD register for controlling the HDO signal output.

Refer to Section 4.14, "Telephone Function" for details of the signal and controlling method.

• **HFO (R13)**

The R13 terminal can output a HFO signal.

The HFO signal is the hand free signal used for the telephone function.

To output the HFO signal, set the R13 port as the HFO output by writing "1" to the CHFO register and fix the R13 register at "1" and the R13HIZ register at "0". Use the HF register for controlling the HFO signal output.

Refer to Section 4.14, "Telephone Function" for details of the signal and controlling method.

4.5.5 I/O memory of output ports

Table 4.5.5.1 shows the I/O addresses and control bits for the output ports.

Table 4.5.5.1 Control bits of output ports

Address	Register								Comment
	D3	D2	D1	D0	Name	Init *1	1	0	
FF06H	FOUTE	0	FOFQ1	FOFQ0	FOUTE 0 *3	0	FOUT	DC	R03 output selection (R03 should be fixed at "1".) Unused FOUT frequency selection [FOFQ1, 0] 0 1 2 3 Frequency fosc1/64 fosc1/8 fosc1 fosc3
	R/W	R	R/W		FOFQ1 FOFQ0	0 0			
FF13H	CHFO	CHDO	CRMO	CTMO	CHFO	0	HFO	DC	R13 output selection (R13 should be fixed at "1".)
	R/W				CHDO	0	HDO	DC	R12 output selection (R12 should be fixed at "1".)
					CRMO	0	XRMUTE	DC	R11 output selection (R11 should be fixed at "1".)
	CTMO	0	XTMUTE	DC	R10 output selection (R10 should be fixed at "1".)				
FF30H	R03HIZ	R02HIZ	R01HIZ	R00HIZ	R03HIZ	0	Hi-Z	Output	R03 (FOUTE=0)/FOUT (FOUTE=1) Hi-z control
	R/W				R02HIZ	0	Hi-Z	Output	R02 (PTOUT=0)/TOUT (PTOUT=1) Hi-z control
					R01HIZ	0	Hi-Z	Output	R01 (BZOUT=0)/BZ (BZOUT=1) Hi-z control
	R00HIZ	0	Hi-Z	Output	R00 (XBZOUT=0)/XBZ (XBZOUT=1) Hi-z control				
FF31H	R03 (FOUT)	R02 (TOUT)	R01 (BZ)	R00 (XBZ)	R03	1	High	Low	R03 output port data (FOUTE=0) Fix at "1" when FOUT is used.
	R/W				R02	1	High	Low	R02 output port data (PTOUT=0) Fix at "1" when TOUT is used.
					R01	1	High	Low	R01 output port data (BZOUT=0) Fix at "1" when BZ is used.
	R00	1	High	Low	R00 output port data (XBZOUT=0) Fix at "1" when XBZ is used.				
FF32H	R13HIZ	R12HIZ	R11HIZ	R10HIZ	R13HIZ	0	Hi-Z	Output	R13 (CHFO=0)/HFO (CHFO=1) Hi-z control
	R/W				R12HIZ	0	Hi-Z	Output	R12 (CHDO=0)/HDO (CHDO=1) Hi-z control
					R11HIZ	0	Hi-Z	Output	R11 (CRMO=0)/XRMUTE (CRMO=1) Hi-z control
	R10HIZ	0	Hi-Z	Output	R10 (CTMO=0)/XTMUTE (CTMO=1) Hi-z control				
FF33H	R13 (HFO)	R12 (HDO)	R11 (XRMUTE)	R10 (XTMUTE)	R13	1	High	Low	R13 output port data (CHFO=0) Fix at "1" when HFO is used.
	R/W				R12	1	High	Low	R12 output port data (CHDO=0) Fix at "1" when HDO is used.
					R11	1	High	Low	R11 output port data (CRMO=0) Fix at "1" when XRMUTE is used.
	R10	1	High	Low	R10 output port data (CTMO=0) Fix at "1" when XTMUTE is used.				
FF34H	R23HIZ	R22HIZ	R21HIZ	R20HIZ	R23HIZ	0	Hi-Z	Output	R20-R23 Hi-z control
	R/W				R22HIZ	0	Hi-Z	Output	
					R21HIZ	0	Hi-Z	Output	
	R20HIZ	0	Hi-Z	Output					
FF35H	R23	R22	R21	R20	R23	1	High	Low	R20-R23 output port data
	R/W				R22	1	High	Low	
					R21	1	High	Low	
	R20	1	High	Low					
FF65H	0	0	BZOUT	XBZOUT	0 *3 0 *3	- *2 - *2			Unused Unused
	R		R/W		BZOUT	0	BZ	DC	R01 output selection (R01 should be fixed at "1".)
FFC1H	CHSEL	PTOUT	CKSEL1	CKSEL0	CHSEL	0	Timer1	Timer0	TOUT output channel selection
	R/W				PTOUT	0	On	Off	TOUT output control
					CKSEL1	0	OSC3	OSC1	Prescaler 1 source clock selection
	CKSEL0	0	OSC3	OSC1	Prescaler 0 source clock selection				

*1 Initial value at initial reset

*2 Not set in the circuit

*3 Constantly "0" when being read

R00HIZ–R03HIZ: R0 port high impedance control register (FF30H)

R10HIZ–R13HIZ: R1 port high impedance control register (FF32H)

R20HIZ–R23HIZ: R2 port high impedance control register (FF34H)

Controls high impedance output of the output port.

When "1" is written: High impedance

When "0" is written: Data output

Reading: Valid

By writing "0" to the high impedance control register, the corresponding output terminal outputs according to the data register. When "1" is written, it shifts into high impedance status.

When an output port (R00–R03, R10–R13) is used for special output, fix the corresponding high impedance control register at "0" (data output).

At initial reset, these registers are set to "0".

R00–R03: R0 output port data register (FF31H)

R10–R13: R1 output port data register (FF33H)

R20–R23: R2 output port data register (FF35H)

Set the output data for the output ports.

When "1" is written: High level output

When "0" is written: Low level output

Reading: Valid

The output port terminals output the data written in the corresponding data registers without changing it. When "1" is written to the register, the output port terminal goes high (VDD), and when "0" is written, the output port terminal goes low (VSS).

When an output port (R00–R03, R10–R13) is used for special output, fix the corresponding data register at "1".

At initial reset, these registers are all set to "1".

XBZOUT: R00 output selection register (FF65H•D0)

Selects the R00 terminal function.

When "1" is written: XBZ output

When "0" is written: General-purpose DC output

Reading: Valid

When using the R00 terminal for the XBZ output, write "1" to this register. Furthermore, fix the R00 register at "1" and the R00HIZ register at "0". Refer to Section 4.12, "Sound Generator", for controlling the XBZ output.

When using the R00 output port for a general-purpose output, fix this register at "0".

At initial reset, this register is set to "0".

BZOUT: R01 output selection register (FF65H•D1)

Selects the R01 terminal function.

When "1" is written: BZ output

When "0" is written: General-purpose DC output

Reading: Valid

When using the R01 terminal for the BZ output, write "1" to this register. Furthermore, fix the R01 register at "1" and the R01HIZ register at "0". Refer to Section 4.12, "Sound Generator", for controlling the BZ output.

When using the R01 output port for a general-purpose output, fix this register at "0".

At initial reset, this register is set to "0".

PTOUT: TOUT output control register (FFC1H•D2)

Controls the TOUT output.

When "1" is written: TOUT output ON

When "0" is written: TOUT output OFF

Reading: Valid

By writing "1" to the PTOUT register when the R02 register has been set to "1" and the R02HIZ register has been set to "0", the TOUT signal is output from the R02 terminal. When "0" is written, the R02 terminal goes high (VDD).

When using the R02 output port for general-purpose output, fix this register at "0".

At initial reset, this register is set to "0".

FOUTE: FOUT output control register (FF06H•D3)

Controls the FOUT output.

When "1" is written: FOUT output ON

When "0" is written: FOUT output OFF

Reading: Valid

By writing "1" to the FOUTE register when the R03 register has been set to "1" and the R03HIZ register has been set to "0", an FOUT signal is output from the R03 terminal. When "0" is written, the R03 terminal goes high (VDD).

When using the R03 output port for general-purpose output, fix this register at "0".

At initial reset, this register is set to "0".

FOFQ0, FOFQ1: FOUT frequency selection register (FF06H•D0, D1)

Selects a frequency of the FOUT signal.

Table 4.5.5.2 FOUT clock frequency

FOFQ1	FOFQ0	Clock frequency
1	1	fosc3
1	0	fosc1
0	1	fosc1 × 1/8
0	0	fosc1 × 1/64

At initial reset, this register is set to "0".

CTMO: R10 output selection register (FF13H•D0)

Selects the R10 terminal function.

When "1" is written: XTMUTE output

When "0" is written: General-purpose DC output

Reading: Valid

When using the R10 terminal for the XTMUTE output, write "1" to this register. Furthermore, fix the R10 register at "1" and the R10HIZ register at "0". Refer to Section 4.14, "Telephone Function", for controlling the XTMUTE output.

When using the R10 output port for a general-purpose output, fix this register at "0".

At initial reset, this register is set to "0".

CRMO: R11 output selection register (FF13H•D1)

Selects the R11 terminal function.

When "1" is written: XRMUTE output

When "0" is written: General-purpose DC output

Reading: Valid

When using the R11 terminal for the XRMUTE output, write "1" to this register. Furthermore, fix the R11 register at "1" and the R11HIZ register at "0". Refer to Section 4.14, "Telephone Function", for controlling the XRMUTE output.

When using the R11 output port for a general-purpose output, fix this register at "0".

At initial reset, this register is set to "0".

CHDO: R12 output selection register (FF13H•D2)

Selects the R12 terminal function.

When "1" is written: HDO output

When "0" is written: General-purpose DC output

Reading: Valid

When using the R12 terminal for the HDO output, write "1" to this register. Furthermore, fix the R12 register at "1" and the R12HIZ register at "0". Refer to Section 4.14, "Telephone Function", for controlling the HDO output.

When using the R12 output port for a general-purpose output, fix this register at "0".

At initial reset, this register is set to "0".

CHFO: R13 output selection register (FF13H•D3)

Selects the R13 terminal function.

When "1" is written: HFO output

When "0" is written: General-purpose DC output

Reading: Valid

When using the R13 terminal for the HFO output, write "1" to this register. Furthermore, fix the R13 register at "1" and the R13HIZ register at "0". Refer to Section 4.14, "Telephone Function", for controlling the HFO output.

When using the R13 output port for a general-purpose output, fix this register at "0".

At initial reset, this register is set to "0".

4.5.6 Programming notes

(1) When using an output port (R00–R03, R10–R13) for special output, fix the corresponding data register (R00–R03, R10–R13) at "1" and the high impedance control register (R00HIZ–R03HIZ, R10HIZ–R13HIZ) at "0" (data output).

Be aware that the output terminal is fixed at a low (Vss) level the same as the DC output if "0" is written to the data registers when the special output has been selected.

Be aware that the output terminal shifts into high impedance status when "1" is written to the high impedance control register.

(2) A hazard may occur when the TOUT, FOUT, BZ or XBZ signal is turned ON and OFF.

(3) When fosc3 is selected for the FOUT signal frequency, it is necessary to control the OSC3 oscillation circuit before output.

Refer to Section 4.3, "Oscillation Circuit", for the control and notes.

4.6 I/O Ports (P00–P03, P10–P13, P20–P23 and P30–P33)

4.6.1 Configuration of I/O ports

The S1C63558 has 16 bits general-purpose I/O ports. Figure 4.6.1.1 shows the configuration of the I/O port.

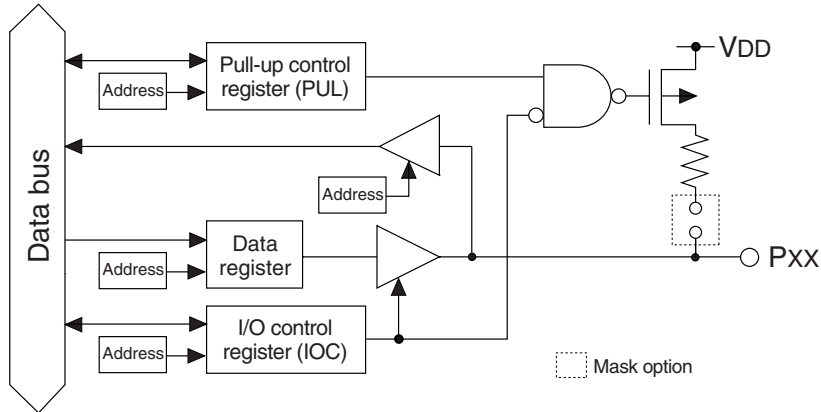

Fig. 4.6.1.1 Configuration of I/O port

The I/O port terminals P10–P13, P30–P33 are shared with the input/output terminals of the serial interface (1) and (2). The P22 and P23 terminals are shared with the special output (CL, FR) terminals. The software can select these functions to be used.

At initial reset, these are all set to the I/O port.

Table 4.6.1.1 shows the setting of the input/output terminals by function selection.

Table 4.6.1.1 Function setting of input/output terminals

Terminal name	Terminal status at initial reset	Special output		Serial I/F (1), (2)		
		CL	FR	Async.	Clk-sync. Master	Clk-sync. Slave
P00–P03	P00–P03 (Input & Pull-up *)	P00–P03	P00–P03	P00–P03	P00–P03	P00–P03
P10	P10 (Input & Pull-up *)	P10	P10	SIN(I)	SIN(I)	SIN(I)
P11	P11 (Input & Pull-up *)	P11	P11	SOUT(O)	SOUT(O)	SOUT(O)
P12	P12 (Input & Pull-up *)	P12	P12	P12	SCLK(O)	SCLK(I)
P13	P13 (Input & Pull-up *)	P13	P13	P13	P13	SRDY(O)
P20	P20 (Input & Pull-up *)	P20	P20	P20	P20	P20
P21	P21 (Input & Pull-up *)	P21	P21	P21	P21	P21
P22	P22 (Input & Pull-up *)	CL	P22	P22	P22	P22
P23	P23 (Input & Pull-up *)	P23	FR	P23	P23	P23
P30	P30 (Input & Pull-up *)	P30	P30	SIN(I)	SIN(I)	SIN(I)
P31	P31 (Input & Pull-up *)	P31	P31	SOUT(O)	SOUT(O)	SOUT(O)
P32	P32 (Input & Pull-up *)	P32	P32	P32	SCLK(O)	SCLK(I)
P33	P33 (Input & Pull-up *)	P33	P33	P33	P33	SRDY(O)

* When "with pull-up resistor" is selected by the mask option (high impedance when "gate direct" is set)

When these ports are used as I/O ports, the ports can be set to either input mode or output mode individually (in 1-bit unit). Modes can be set by writing data to the I/O control registers.

Refer to Section 4.11, "Serial Interface", for control of the serial interface.

4.6.2 Mask option

In the I/O ports, the output specification during output mode can be selected from complementary output and N-channel open drain output by mask option. They are selected in 1-bit units.

When N-channel open drain output is selected, do not apply a voltage exceeding the power supply voltage to the port.

The mask option also allows selection of whether the pull-up resistor is used or not during input mode. They are selected in 1-bit units or 4-bit units depending on the terminal group.

Ports to be selected in 1-bit units: P20, P21, P22, P23

Ports to be selected in 4-bit units: P00–P03, P10–P13, P30–P33

When "without pull-up" during the input mode is selected, take care that the floating status does not occur.

This option is effective even when I/O ports are used for special output or input/output of the serial interface.

4.6.3 I/O control registers and input/output mode

Input or output mode can be set for the I/O ports by writing data into the corresponding I/O control registers IOCxx.

To set the input mode, write "0" to the I/O control register. When an I/O port is set to input mode, it becomes high impedance status and works as an input port.

However, when the pull-up explained in the following section has been set by software, the input line is pulled up only during this input mode.

To set the output mode, write "1" is to the I/O control register. When an I/O port is set to output mode, it works as an output port, it outputs a high level (VDD) when the port output data is "1", and a low level (VSS) when the port output data is "0".

If perform the read out in each mode; when output mode, the register value is read out, and when input mode, the port value is read out.

At initial reset, the I/O control registers are set to "0", and the I/O ports enter the input mode.

The I/O control registers of the ports that are set as special output or input/output for the serial interface can be used as general purpose registers that do not affect the I/O control. (See Table 4.6.1.1.)

4.6.4 Pull-up during input mode

A pull-up resistor that operates during the input mode is built into each I/O port of the S1C63558. Mask option can set the use or non-use of this pull-up.

The pull-up resistor becomes effective by writing "1" to the pull-up control register PULxx that corresponds to each port, and the input line is pulled up during the input mode. When "0" has been written, no pull-up is done.

At initial reset, the pull-up control registers are set to "1".

The pull-up control registers of the ports in which "without pull-up" have been selected can be used as general purpose registers.

Even when "with pull-up" has been selected, the pull-up control registers of the ports, that are set as special output or output for the serial interface, can be used as general purpose registers that do not affect the pull-up control. (See Table 4.6.1.1.)

The pull-up control registers of the port, that are set as input for the serial interface, function the same as the I/O port.

4.6.5 Special outputs (CL, FR)

The I/O ports P22 and P23 can be used as special output ports that output CL and FR signals by switching the function with software. Since P22 and P23 are set to I/O port (input mode) at initial reset, when using the special outputs, select the special output function using the EXLCDC register.

The data registers, I/O control registers and pull-up control registers of the ports set in the special output can be used as general purpose registers that do not affect the output.

When "1" is written to the EXLCDC register, P22 is set to the CL output port and P23 is set to the FR output port.

The CL and FR signals are LCD synchronous signal (CL) and LCD flame signal (FR) for externally expanded LCD driver, and are output from the P22 terminal and P23 terminal when the functions are switched by the EXLCDC register.

The following tables show the frequencies of the CL and FR signals.

Table 4.6.5.1 CL signal frequency

OSC1 oscillation frequency	When 1/8 duty is selected	When 1/16 duty is selected	When 1/17 duty is selected
32.768 kHz	512 Hz	1,024 Hz	1,024 Hz

Table 4.6.5.2 FR signal frequency

OSC1 oscillation frequency	When 1/8 duty is selected	When 1/16 duty is selected	When 1/17 duty is selected
32.768 kHz	32 Hz	32 Hz	30.12 Hz

Refer to Section 4.7, "LCD Driver", for control of the LCD drive duty.

Note: A hazard may occur when the CL signal or FR signal is turned ON or OFF (when the port function is switched).

Figure 4.6.5.1 shows the output waveforms of CL and FR signals.

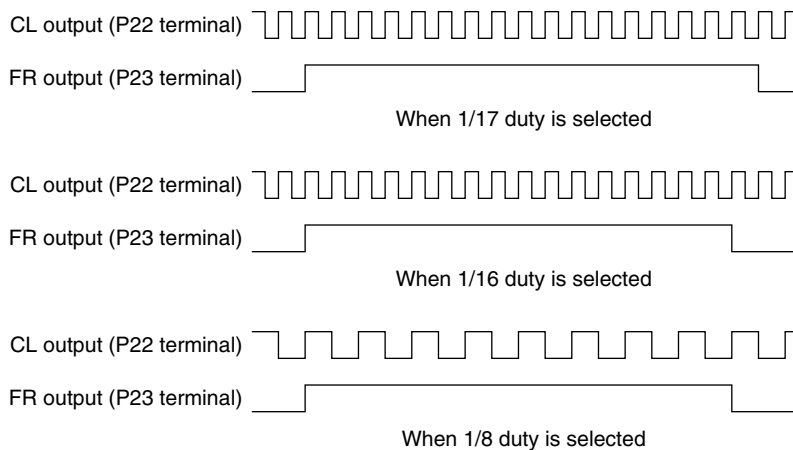

Fig. 4.6.5.1 Output waveforms of CL and FR signals

4.6.6 I/O memory of I/O ports

Tables 4.6.6.1(a) and (b) show the I/O addresses and the control bits for the I/O ports.

Table 4.6.6.1(a) Control bits of I/O ports

Address	Register								Comment
	D3	D2	D1	D0	Name	Init *1	1	0	
FF40H	IOC03	IOC02	IOC01	IOC00	IOC03	0	Output	Input	P00–P03 I/O control register
	R/W				IOC02	0	Output	Input	
					IOC01	0	Output	Input	
					IOC00	0	Output	Input	
FF41H	PUL03	PUL02	PUL01	PUL00	PUL03	1	On	Off	P00–P03 pull-up control register
	R/W				PUL02	1	On	Off	
					PUL01	1	On	Off	
					PUL00	1	On	Off	
FF42H	P03	P02	P01	P00	P03	–*2	High	Low	P00–P03 I/O port data
	R/W				P02	–*2	High	Low	
					P01	–*2	High	Low	
					P00	–*2	High	Low	
FF44H	IOC13	IOC12	IOC11	IOC10	IOC13	0	Output	Input	P13 I/O control register General-purpose register when SIF (clock sync. slave) is selected P12 I/O control register General-purpose register when SIF (clock sync.) is selected P11 I/O control register (ESIF=0) General-purpose register when SIF is selected P10 I/O control register (ESIF=0) General-purpose register when SIF is selected
	R/W				IOC12	0	Output	Input	
					IOC11	0	Output	Input	
					IOC10	0	Output	Input	
FF45H	PUL13	PUL12	PUL11	PUL10	PUL13	1	On	Off	P13 pull-up control register General-purpose register when SIF (clock sync. slave) is selected P12 pull-up control register General-purpose register when SIF (clock sync. master) is selected SCLK (I) pull-up control register when SIF (clock sync. slave) is selected P11 pull-up control register (ESIF=0) General-purpose register when SIF is selected P10 pull-up control register (ESIF=0) SIN pull-up control register when SIF is selected
	R/W				PUL12	1	On	Off	
					PUL11	1	On	Off	
					PUL10	1	On	Off	
FF46H	P13 (XSRDY)	P12 (XSCLK)	P11 (SOUT)	P10 (SIN)	P13	–*2	High	Low	P13 I/O port data General-purpose register when SIF (clock sync. slave) is selected P12 I/O port data General-purpose register when SIF (clock sync.) is selected P11 I/O port data (ESIF=0) General-purpose register when SIF is selected P10 I/O port data (ESIF=0) General-purpose register when SIF is selected
	R/W				P12	–*2	High	Low	
					P11	–*2	High	Low	
					P10	–*2	High	Low	
FF48H	IOC23	IOC22	IOC21	IOC20	IOC23	0	Output	Input	P23 I/O control register (EXLDCD=0) General-purpose register when FR output is selected P22 I/O control register (EXLDCD=0) General-purpose register when CL output is selected P21 I/O control register P20 I/O control register
	R/W				IOC22	0	Output	Input	
					IOC21	0	Output	Input	
					IOC20	0	Output	Input	
FF49H	PUL23	PUL22	PUL21	PUL20	PUL23	1	On	Off	P23 pull-up control register (EXLDCD=0) General-purpose register when FR output is selected P22 pull-up control register (EXLDCD=0) General-purpose register when CL output is selected P21 pull-up control register P20 pull-up control register
	R/W				PUL22	1	On	Off	
					PUL21	1	On	Off	
					PUL20	1	On	Off	
FF4AH	P23 (FR)	P22 (CL)	P21	P20	P23	–*2	High	Low	P23 I/O port data (EXLDCD=0) General-purpose register when FR output is selected P22 I/O port data (EXLDCD=0) General-purpose register when CL output is selected P21 I/O port data P20 I/O port data
	R/W				P22	–*2	High	Low	
					P21	–*2	High	Low	
					P20	–*2	High	Low	

*1 Initial value at initial reset

*3 Constantly "0" when being read

*2 Not set in the circuit

Table 4.6.6.1(b) Control bits of I/O ports

Address	Register				Name	Init *1	1	0	Comment	
	D3	D2	D1	D0						
FF4CH	IOC33	IOC32	IOC31	IOC30	IOC33	0	Output	Input	P33 I/O control register	
					IOC32	0	Output	Input	General-purpose register when SIF (clock sync. slave) is selected P32 I/O control register	
	R/W				IOC31	0	Output	Input	General-purpose register when SIF (clock sync.) is selected P31 I/O control register (ESIFS=0)	
					IOC30	0	Output	Input	General-purpose register when SIF is selected P30 I/O control register (ESIFS=0) General-purpose register when SIF is selected	
FF4DH	PUL33	PUL32	PUL31	PUL30	PUL33	1	On	Off	P33 pull-up control register	
					PUL32	1	On	Off	General-purpose register when SIF (clock sync. slave) is selected P32 pull-up control register	
	R/W				PUL31	1	On	Off	General-purpose register when SIF (clock sync. master) is selected SCLK (I) pull-up control register when SIF (clock sync. slave) is selected	
					PUL30	1	On	Off	P31 pull-up control register (ESIFS=0) General-purpose register when SIF is selected P30 pull-up control register (ESIFS=0) SIN pull-up control register when SIF is selected	
FF4EH	P33 (XSRDYS)	P32 (XSCLKS)	P31 (SOUTS)	P30 (SINS)	P33	-*2	High	Low	P33 I/O port data	
					P32	-*2	High	Low	General-purpose register when SIF (clock sync. slave) is selected P32 I/O port data	
	R/W				P31	-*2	High	Low	General-purpose register when SIF (clock sync.) is selected P31 I/O port data (ESIFS=0)	
					P30	-*2	High	Low	General-purpose register when SIF is selected P30 I/O port data (ESIFS=0) General-purpose register when SIF is selected	
FF58H	0	SMD1S	SMD0S	ESIFS	0 *3	-*2			Unused	
	R	R/W			SMD1S	0] Serial I/F (2) mode selection Serial I/F (2) enable (P3x port function selection)
					SMD0S	0				
					ESIFS	0	SIF	I/O		
FF61H	EXLCDC	ALOFF	ALON	LPAGE	EXLCDC	0	Enable	Disable	Expanded LCD driver signal control	
					ALOFF	1	All Off	Normal	LCD all Off control	
	R/W				ALON	0	All On	Normal	LCD all On control	
					LPAGE	0	F100-F15F	F000-F05F	Display memory area selection (when 1/8 duty is selected) General-purpose register when 1/16, 1/17 duty is selected	
FF70H	0	SMD1	SMD0	ESIF	0 *3	-*2			Unused	
	R	R/W			SMD1	0] Serial I/F (1) mode selection Serial I/F (1) enable (P1x port function selection)
					SMD0	0				
					ESIF	0	SIF	I/O		

*1 Initial value at initial reset

*2 Not set in the circuit

*3 Constantly "0" when being read

(1) Selection of port function

EXLCDC: Expanded LCD driver signal control register (FF61H•D3)

Sets P22 and P23 to the CL signal and the FR signal output ports.

When "1" is written: CL/FR signal output

When "0" is written: I/O port

Reading: Valid

When setting P22 to the CL (LCD synchronous signal) output and P23 to the FR (LCD frame signal) output, write "1" to this register and when they are used as I/O ports, write "0".

The CL and FR signals are output from the P22 terminal and P23 terminal immediately after the functions are switched by the EXLCDC register. In this case, the control registers for P22 and P23 can be used as general purpose registers that do not affect the output.

At initial reset, this register is set to "0".

ESIF: Serial interface (1) enable register (FF70H•D0)

Selects function for P10–P13.

When "1" is written: Serial interface (1) input/output port

When "0" is written: I/O port

Reading: Valid

When using the serial interface (1), write "1" to this register and when P10–P13 are used as the I/O port, write "0". The terminal configuration within P10–P13 that are used for the serial interface (1) is decided by the transfer mode (7-bit asynchronous, 8-bit asynchronous, clock synchronous slave, clock synchronous master) selected with the SMD1 and SMD0 registers.

In the clock synchronous slave mode, all the P10–P13 ports are set to the serial interface (1) input/output port. In the clock synchronous master mode, P10–P12 are set to the serial interface (1) input/output port and P13 can be used as the I/O port. In the 8/7-bit asynchronous mode, P10 and P11 are set to the serial interface (1) input/output port and P12 and P13 can be used as the I/O port.

At initial reset, this register is set to "0".

ESIFS: Serial interface (2) enable register (FF58H•D0)

Selects function for P30–P33.

When "1" is written: Serial interface (2) input/output port

When "0" is written: I/O port

Reading: Valid

When using the serial interface (2), write "1" to this register and when P30–P33 are used as the I/O port, write "0". The terminal configuration within P30–P33 that are used for the serial interface (2) is decided by the transfer mode (7-bit asynchronous, 8-bit asynchronous, clock synchronous slave, clock synchronous master) selected with the SMD1S and SMD0S registers.

In the clock synchronous slave mode, all the P30–P33 ports are set to the serial interface (2) input/output port. In the clock synchronous master mode, P30–P32 are set to the serial interface (2) input/output port and P33 can be used as the I/O port. In the 8/7-bit asynchronous mode, P30 and P31 are set to the serial interface (2) input/output port and P32 and P33 can be used as the I/O port.

At initial reset, this register is set to "0".

(2) I/O port control

P00–P03: P0 I/O port data register (FF42H)

P10–P13: P1 I/O port data register (FF46H)

P20–P23: P2 I/O port data register (FF4AH)

P30–P33: P3 I/O port data register (FF4EH)

I/O port data can be read and output data can be set through these registers.

• When writing data

When "1" is written: High level

When "0" is written: Low level

When an I/O port is set to the output mode, the written data is output unchanged from the I/O port terminal. When "1" is written as the port data, the port terminal goes high (VDD), and when "0" is written, the terminal goes low (VSS).

Port data can be written also in the input mode.

• When reading data

When "1" is read: High level

When "0" is read: Low level

The terminal voltage level of the I/O port is read out. When the I/O port is in the input mode the voltage level being input to the port terminal can be read out; in the output mode the register value can be read.

When the terminal voltage is high (V_{DD}) the port data that can be read is "1", and when the terminal voltage is low (V_{SS}) the data is "0".

When "with pull-up resistor" has been selected with the mask option and the PUL register is set to "1", the built-in pull-up resistor goes ON during input mode, so that the I/O port terminal is pulled up.

The data registers of the port, which are set for the special output (P22, P23) or input/output of the serial interface (P10–P13 or P30–P33), become general-purpose registers that do not affect the input/output.

Note: When in the input mode, I/O ports are changed from low to high by pull-up resistor, the rise of the waveform is delayed on account of the time constant of the pull-up resistor and input gate capacitance. Hence, when fetching input ports, set an appropriate wait time.

Particular care needs to be taken of the key scan during key matrix configuration.

Make this waiting time the amount of time or more calculated by the following expression.

$$10 \times C \times R$$

C: terminal capacitance 5 pF + parasitic capacitance ? pF

R: pull-up resistance 330 kΩ

IOC00–IOC03: P0 port I/O control register (FF40H)

IOC10–IOC13: P1 port I/O control register (FF44H)

IOC20–IOC23: P2 port I/O control register (FF48H)

IOC30–IOC33: P3 port I/O control register (FF4CH)

The input and output modes of the I/O ports are set with these registers.

When "1" is written: Output mode

When "0" is written: Input mode

Reading: Valid

The input and output modes of the I/O ports are set in 1-bit unit.

Writing "1" to the I/O control register makes the corresponding I/O port enter the output mode, and writing "0" induces the input mode.

At initial reset, these registers are all set to "0", so the I/O ports are in the input mode.

The I/O control registers of the port, which are set for the special output (P22, P23) or input/output of the serial interface (P10–P13 or P30–P33), become general-purpose registers that do not affect the input/output.

PUL00–PUL03: P0 port pull-up control register (FF41H)

PUL10–PUL13: P1 port pull-up control register (FF45H)

PUL20–PUL23: P2 port pull-up control register (FF49H)

PUL30–PUL33: P3 port pull-up control register (FF4DH)

The pull-up during the input mode are set with these registers.

When "1" is written: Pull-up ON

When "0" is written: Pull-up OFF

Reading: Valid

The built-in pull-up resistor which is turned ON during input mode is set to enable in 1-bit units. (The pull-up resistor is included into the ports selected by the mask option.)

By writing "1" to the pull-up control register, the corresponding I/O ports are pulled up (during input mode), while writing "0" turns the pull-up function OFF.

At initial reset, these registers are all set to "1", so the pull-up function is set to ON.

The pull-up control registers of the ports in which the pull-up resistor is not included become the general purpose register. The registers of the ports that are set as special output or output for the serial interface can also be used as general purpose registers that do not affect the pull-up control.

The pull-up control registers of the port that are set as input for the serial interface function the same as the I/O port.

4.6.7 Programming notes

- (1) When in the input mode, I/O ports are changed from low to high by pull-up resistor, the rise of the waveform is delayed on account of the time constant of the pull-up resistor and input gate capacitance. Hence, when fetching input ports, set an appropriate wait time.

Particular care needs to be taken of the key scan during key matrix configuration.

Make this waiting time the amount of time or more calculated by the following expression.

$$10 \times C \times R$$

C: terminal capacitance 5 pF + parasitic capacitance ? pF

R: pull-up resistance 330 k Ω

- (2) When special output (CL, FR) has been selected, a hazard may occur when the signal is turned ON or OFF.

4.7 LCD Driver (COM0–COM16, SEG0–SEG39)

4.7.1 Configuration of LCD driver

The S1C63558 has 17 common terminals (COM0–COM16) and 40 segment terminals (SEG0–SEG39), so that it can drive a dot matrix type LCD with a maximum of 680 (40 × 17) dots.

The driving method is 1/17 duty, 1/16 duty or 1/8 duty dynamic drive with four voltages (1/4 bias), VC1, VC23, VC4 and VC5.

LCD display ON/OFF can be controlled by the software.

4.7.2 Mask option

The COM8–COM16 terminals can be set as the SEG47–SEG40 terminals by mask option. In this case, only 1/8 drive duty can be selected, so a dot matrix type LCD with a maximum of 384 (48 × 8) dots can be driven. When 48 segments × 8 commons is selected, COM terminals change to SEG terminals as follows:
 COM16 → SEG40 COM15 → SEG41 COM14 → SEG42 COM13 → SEG43 COM12 → SEG44
 COM11 → SEG45 COM10 → SEG46 COM9 → SEG47 COM8 → SEG47

This option is valid on the PRC board, however, the SEG47–SEG40 terminals are separately provided. Therefore, be aware that the COM8–COM16 terminals cannot be changed to the SEG47–SEG40.

4.7.3 Power supply for LCD driving

VC1, VC23, VC4 and VC5 are the LCD (1/4 bias) drive voltages generated by the LCD system voltage circuit. These four output voltages can only be supplied to the externally expanded LCD driver. Turning the LCD system voltage circuit ON or OFF is controlled with the LPWR register. When LPWR is set to "1", the LCD system voltage circuit outputs the LCD drive voltages VC1, VC23, VC4 and VC5 to the LCD driver.

The LCD system voltage circuit generates VC23 with the voltage regulator incorporated in itself, and generates three other voltages by boosting or reducing the voltage VC23. Table 4.7.3.1 shows the VC1, VC23, VC4 and VC5 voltage values and boost/reduce status.

Table 4.7.3.1 LCD drive voltage when generated internally

LCD drive voltage	Boost/reduce status	Voltage value [V]
VC1	VC2 × 0.5	1.13
VC23	VC2 (standard)	2.25
VC4	VC2 × 1.5	3.38
VC5	VC2 × 2	4.50

Note: The LCD drive voltage can be adjusted by the software (see Section 4.7.6). Values in the table are typical values.

4.7.4 LCD display control (ON/OFF) and switching of duty

(1) Display ON/OFF control

The S1C63558 incorporates the ALON and ALOFF registers to blink display. When "1" is written to ALON, all the dots go ON, and when "1" is written to ALOFF, all the dots go OFF. At such a time, an ON waveform or an OFF waveform is output from SEG terminals. When "0" is written to these registers, normal display is performed. Furthermore, when "1" is written to both of the ALON and ALOFF, ALON (all ON) has priority over the ALOFF (all OFF).

(2) Switching of drive duty

In the S1C63558, the drive duty can be set to 1/17, 1/16 or 1/8 by the software. This setting is done using the LDUTY1 and LDUTY0 registers as shown in Table 4.7.4.1.

Table 4.7.4.1 LCD drive duty setting

LDUTY1	LDUTY0	Drive duty	Common terminal used	Maximum segment number	When 48 × 8 mask option is selected
1	*	1/8	COM0–COM7	320 (40 × 8)	384 (48 × 8)
0	1	1/16	COM0–COM15	640 (40 × 16)	Invalid
0	0	1/17	COM0–COM16	680 (40 × 17)	Invalid

When 48 segments × 8 commons is selected by mask option, COM8–COM16 are changed to SEG47–SEG40. Therefore, COM8–COM16 cannot be used. In this case, be sure to set the drive duty to 1/8 by the software.

Table 4.7.4.2 shows the frame frequencies corresponding to the OSC1 oscillation frequency and drive duty.

Table 4.7.4.2 Frame frequency

OSC1 oscillation frequency	When 1/8 duty is selected	When 1/16 duty is selected	When 1/17 duty is selected
32.768 kHz	32 Hz	32 Hz	30.12 Hz

Figure 4.7.4.1 shows the dynamic drive waveform for 1/4 bias.

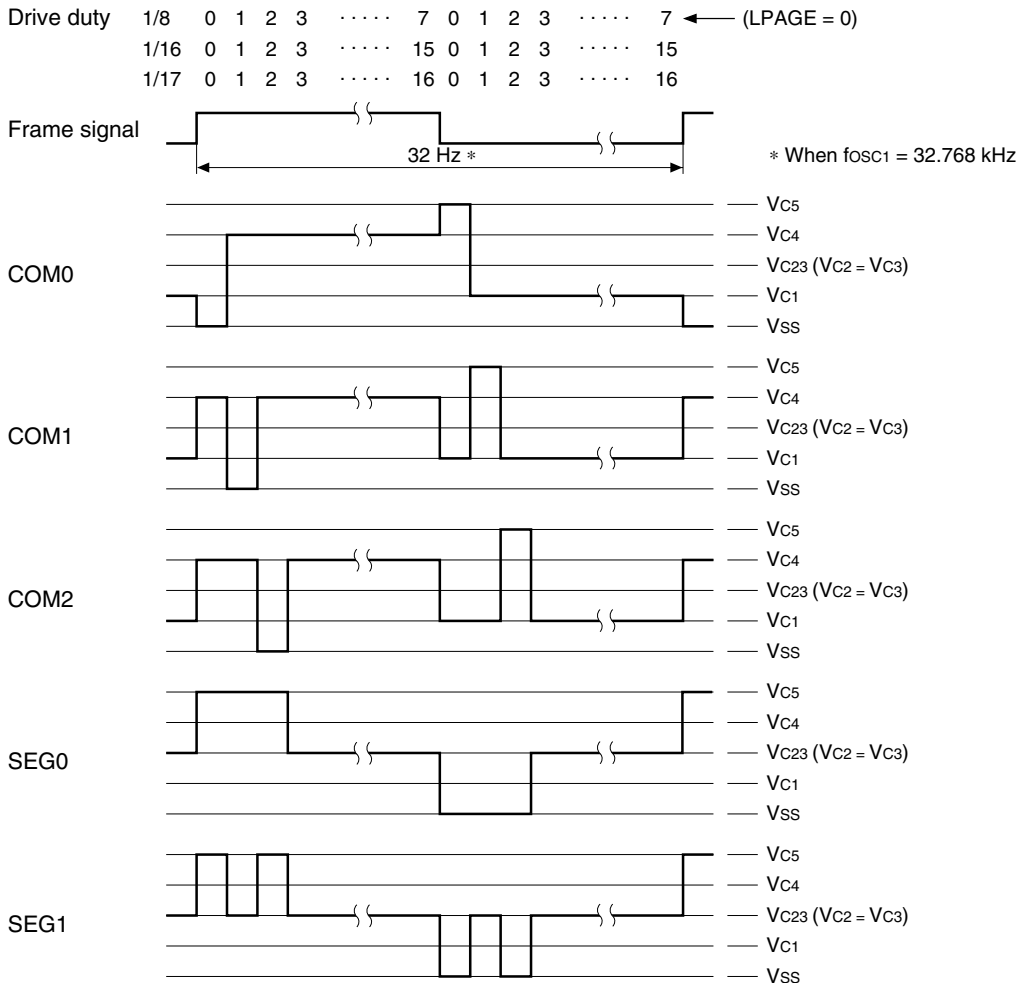
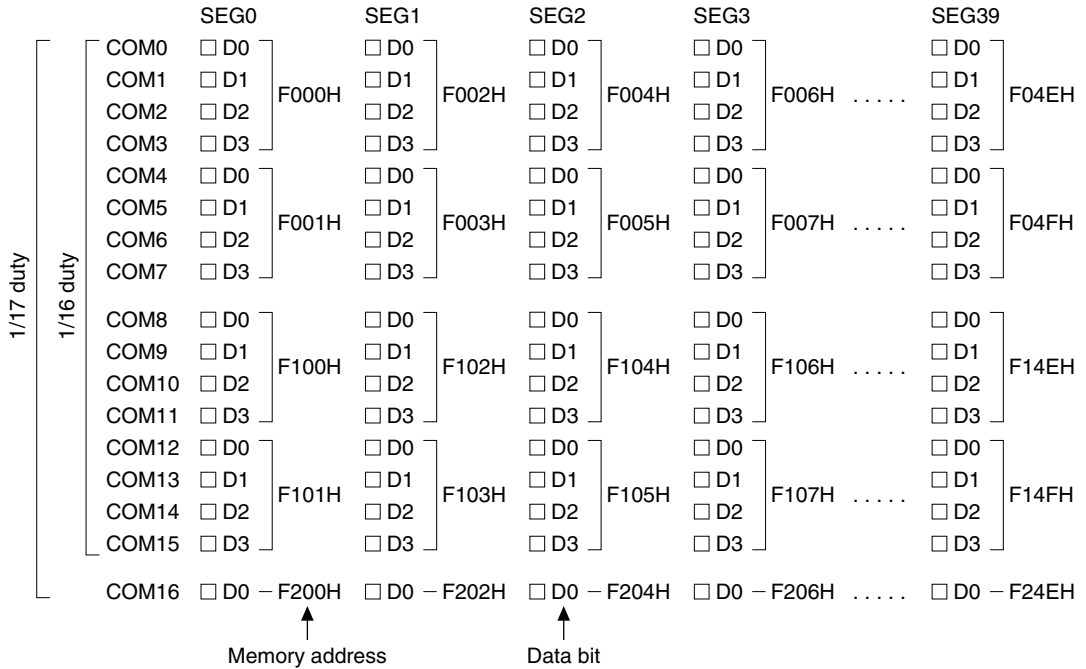

Fig. 4.7.4.1 Drive waveform for 1/4 bias

4.7.5 Display memory

The display memory is allocated to F000H–F25EH in the data memory area and the addresses and the data bits correspond to COM and SEG outputs as shown in Figure 4.7.5.1.



(a) When 1/17 or 1/16 duty is selected

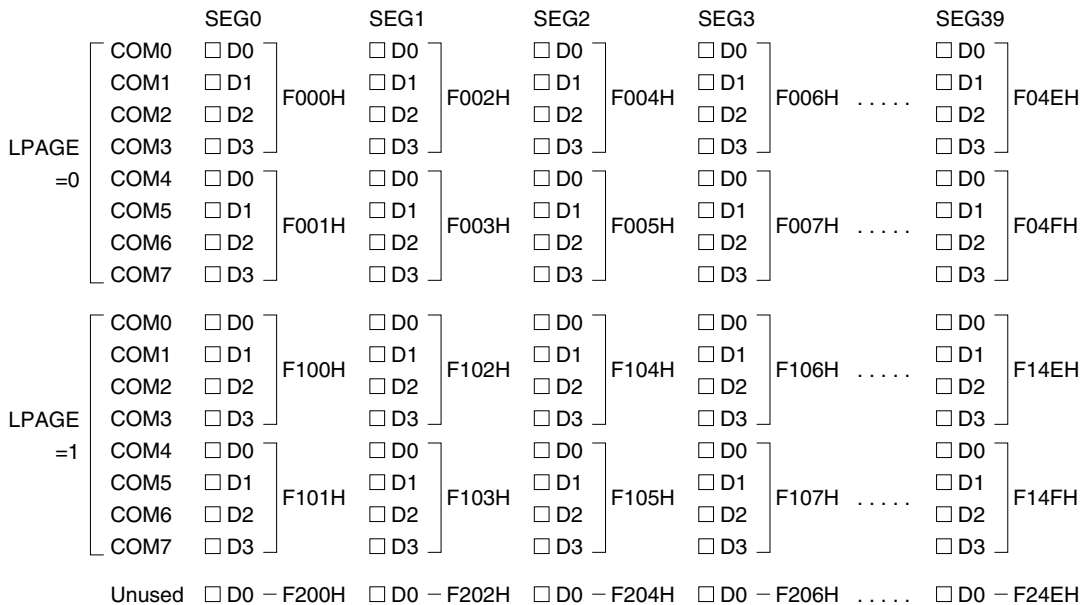

(b) When 1/8 duty is selected

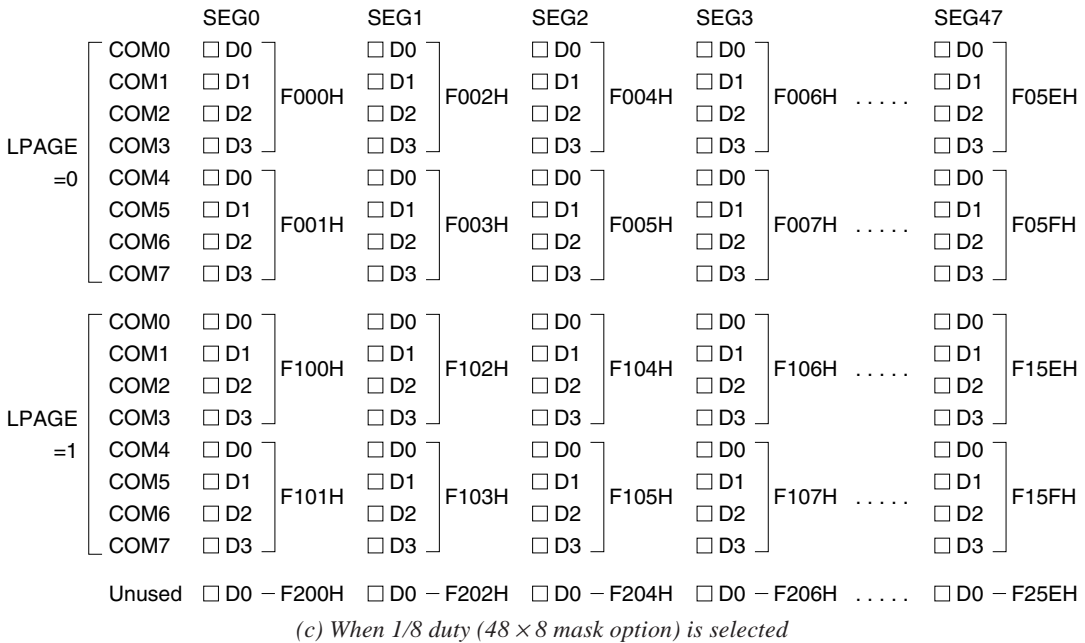

Fig. 4.7.5.1 Correspondence between display memory and LCD dot matrix

When a bit in the display memory is set to "1", the corresponding LCD dot goes ON, and when it is set to "0", the dot goes OFF.

At 1/17 (1/16) duty drive, all data of COM0–COM16 (15) is output.

At 1/8 duty drive, data only corresponding to COM0–COM7 is output. However, since the display memory has capacity for two screens, it is designed so that the memory for COM8–COM15 shown in Figure 4.7.5.1 (a) can also be used as COM0–COM15. Select either F000H–F05FH or F100H–F15FH for the area to be displayed (to be output from COM0–COM7 terminals) using the LPAGE register. It can switch the screen in an instant.

At initial reset, the data memory content becomes undefined hence, there is need to initialize using the software.

The display memory has read/write capability, and the addresses that have not been used for LCD display can be used as general purpose registers. F050H–F05FH, F150H–F15FH, F250H, F252H, F254H, . . . , F25EH can be used as general purpose registers except when 48 × 8 is selected by mask option.

Note: When a program that access no memory mounted area (F060H–F0FFH, F160H–F1FFH, F201H, F203H, . . . , F25FH) is made, the operation is not guaranteed.

4.7.6 LCD contrast adjustment

In the S1C63558, the LCD contrast can be adjusted by the software.

It is realized by controlling the voltages V_{C1} , V_{C23} , V_{C4} and V_{C5} output from the LCD system voltage circuit. When these voltages are supplied to the externally expanded LCD driver, the expanded LCD contrast is adjusted at the same time.

The contrast can be adjusted to 16 levels as shown in Table 4.7.6.1.

Table 4.7.6.1 LCD contrast

No.	LC3	LC2	LC1	LC0	Contrast
0	0	0	0	0	light
1	0	0	0	1	↑
2	0	0	1	0	
3	0	0	1	1	
4	0	1	0	0	
5	0	1	0	1	
6	0	1	1	0	
7	0	1	1	1	
8	1	0	0	0	
9	1	0	0	1	
10	1	0	1	0	
11	1	0	1	1	
12	1	1	0	0	
13	1	1	0	1	
14	1	1	1	0	↓
15	1	1	1	1	dark

Setting the LC3–LC0 register affects the V_{C23} voltage, and other voltages change according to the V_{C23} . As a result, the LCD contrast is adjusted.

The supply voltage V_{DD} within the range from 2.2 to 2.5 V affects the V_{C23} voltage. Ordinarily, V_{C23} is 2.4 V (when $V_{DD} = 2.5$ to 5.5 V) in the highest-contrast setting (No. 15 in Table 4.7.6.1), note, however, that V_{C23} will be $V_{DD} - 0.1$ V when $V_{DD} = 2.2$ to 2.5 V.

At room temperature, use setting number 7 or 8 as standard.

Since the contents of LC0–LC3 are undefined at initial reset, initialize it by the software.

4.7.7 I/O memory of LCD driver

Table 4.7.7.1 shows the I/O addresses and the control bits for the LCD driver. Figure 4.7.7.1 shows the display memory map.

Table 4.7.7.1 LCD driver control bits

Address	Register				Register				Comment
	D3	D2	D1	D0	Name	Init *1	1	0	
FF60H	LDUTY1	LDUTY0	Dummy	LPWR	LDUTY1	0			LCD drive duty switch General-purpose register LCD power On/Off
	R/W				LDUTY0	0			
					Dummy	0			
					LPWR	0	On	Off	
FF61H	EXLDCDC	ALOFF	ALON	LPAGE	EXLDCDC	0	Enable	Disable	Expanded LCD driver signal control LCD all Off control LCD all On control Display memory area selection (when 1/8 duty is selected) General-purpose register when 1/16, 1/17 duty is selected
	R/W				ALOFF	1	All Off	Normal	
					ALON	0	All On	Normal	
					LPAGE	0	F100-F15F	F000-F05F	
FF62H	LC3	LC2	LC1	LC0	LC3	- *2			LCD contrast adjustment Contrast Light - Dark
	R/W				LC2	- *2			
					LC1	- *2			
					LC0	- *2			

- *1 Initial value at initial reset
- *2 Not set in the circuit
- *3 Constantly "0" when being read

(a) When 40 × 17 is selected

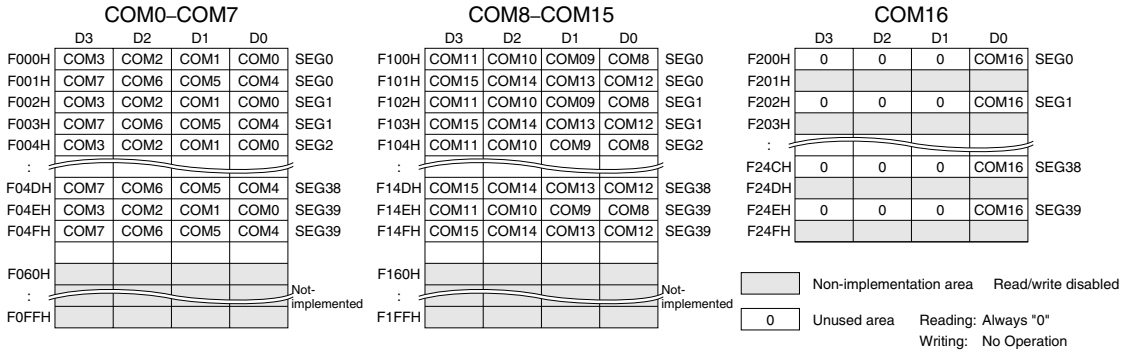

(b) When 48 × 8 is selected

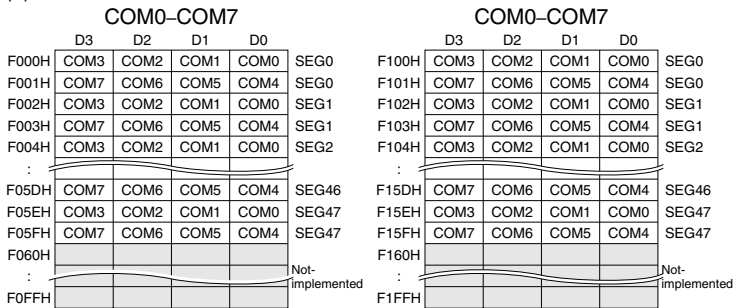

Fig. 4.7.7.1 Display memory map

LPWR: LCD power control (ON/OFF) register (FF60H•D0)

Turns the LCD system voltage circuit ON and OFF.

When "1" is written: ON

When "0" is written: OFF

Reading: Valid

When "1" is written to the LPWR register, the LCD system voltage circuit goes ON and generates the LCD drive voltage. When "0" is written, all the LCD drive voltages go to V_{SS} level.

It takes about 100 msec for the LCD drive voltage to stabilize after starting up the LCD system voltage circuit by writing "1" to the LPWR register.

At initial reset, this register is set to "0".

LDUTY0, LDUTY1: LCD drive duty switching register (FF60H•D2, D3)

Selects the LCD drive duty.

Table 4.7.7.2 Drive duty setting

LDUTY1	LDUTY0	Drive duty	Common terminal used	Maximum segment number	When 48 × 8 mask option is selected
1	*	1/8	COM0–COM7	320 (40 × 8)	384 (48 × 8)
0	1	1/16	COM0–COM15	640 (40 × 16)	Invalid
0	0	1/17	COM0–COM16	680 (40 × 17)	Invalid

At initial reset, this register is set to "0". When 48 × 8 is selected by mask option, reset to 1/8 duty.

ALON: LCD all ON control register (FF61H•D1)

Displays the all LCD dots ON.

When "1" is written: All LCD dots displayed

When "0" is written: Normal display

Reading: Valid

By writing "1" to the ALON register, all the LCD dots goes ON, and when "0" is written, it returns to normal display.

This function outputs an ON waveform to the SEG terminals, and does not affect the content of the display memory.

ALON has priority over ALOFF.

At initial reset, this register is set to "0".

ALOFF: LCD all OFF control register (FF61H•D2)

Fade outs the all LCD dots.

When "1" is written: All LCD dots fade out

When "0" is written: Normal display

Reading: Valid

By writing "1" to the ALOFF register, all the LCD dots goes OFF, and when "0" is written, it returns to normal display.

This function outputs an OFF waveform to the SEG terminals, and does not affect the content of the display memory.

At initial reset, this register is set to "1".

LPAGE: LCD display memory selection register (FF61H•D0)

Selects the display memory area at 1/8 duty drive.

When "1" is written: F100H–F14FH (when 40 × 17 is selected), F100H–F15FH (when 48 × 8 is selected)

When "0" is written: F000H–F04FH (when 40 × 17 is selected), F000H–F05FH (when 48 × 8 is selected)

Reading: Valid

By writing "1" to the LPAGE register, the data set in F100H–F14FH/F15FH (the second half of the display memory) is displayed, and when "0" is written, the data set in F000H–F04FH/F05FH (the first half of the display memory) is displayed.

This function is valid only when 1/8 duty is selected, and when 1/16 or 1/17 duty is selected, this register can be used as a general purpose register.

At initial reset, this register is set to "0".

LC3–LC0: LCD contrast adjustment register (FF62H)

Adjusts the LCD contrast.

LC3–LC0 = 0000B light

: :

LC3–LC0 = 1111B dark

At room temperature, use setting number 7 or 8 as standard.

At initial reset, LC3–LC0 are undefined.

4.7.8 Programming notes

- (1) When a program that access no memory mounted area (F060H–F0FFH, F160H–F1FFH, F201H, F203H, . . . , F25FH) is made, the operation is not guaranteed.
- (2) Because at initial reset, the contents of display memory and LC3–LC0 (LCD contrast) are undefined, there is need to initialize by the software. Furthermore, take care of the registers LPWR and ALOFF because these are set so that the display goes OFF.
- (3) The COM8–COM16 terminals can be set as the SEG47–SEG40 terminals by mask option. In this case, only 1/8 drive duty can be selected, so a dot matrix type LCD with a maximum of 384 (48 × 8) dots can be driven. When 48 segments × 8 commons is selected, COM terminals change to SEG terminals as follows:
 COM16 → SEG40 COM15 → SEG41 COM14 → SEG42 COM13 → SEG43 COM12 → SEG44
 COM11 → SEG45 COM10 → SEG46 COM9 → SEG47 COM8 → SEG47

This option is valid on the PRC board, however, the SEG47–SEG40 terminals are separately provided. Therefore, be aware that the COM8–COM16 terminals cannot be changed to the SEG47–SEG40.

4.8 Clock Timer

4.8.1 Configuration of clock timer

The S1C63558 has a built-in clock timer that uses OSC1 (crystal oscillator) as the source oscillator. The clock timer is configured of an 8-bit binary counter that serves as the input clock, fOSC1 divided clock output from the prescaler. Timer data (128–16 Hz and 8–1 Hz) can be read out by the software.

Figure 4.8.1.1 is the block diagram for the clock timer.

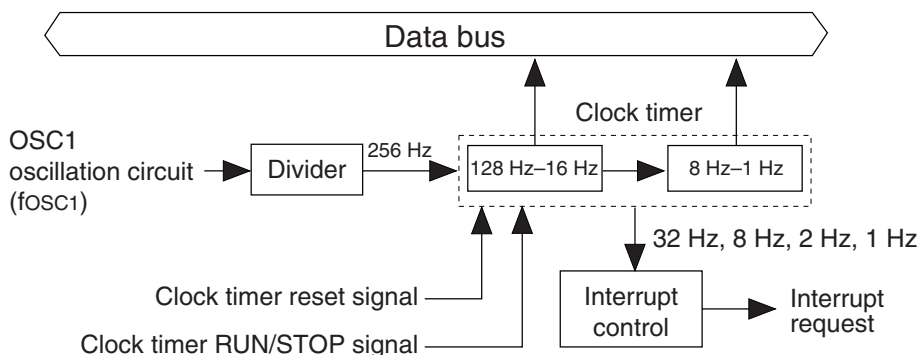

Fig. 4.8.1.1 Block diagram for the clock timer

Ordinarily, this clock timer is used for all types of timing functions such as clocks.

4.8.2 Data reading and hold function

The 8 bits timer data are allocated to the address FF79H and FF7AH.

<FF79H>	D0: TM0 = 128 Hz	D1: TM1 = 64 Hz	D2: TM2 = 32 Hz	D3: TM3 = 16 Hz
<FF7AH>	D0: TM4 = 8 Hz	D1: TM5 = 4 Hz	D2: TM6 = 2 Hz	D3: TM7 = 1 Hz

Since the clock timer data has been allocated to two addresses, a carry is generated from the low-order data within the count (TM0–TM3: 128–16 Hz) to the high-order data (TM4–TM7: 8–1 Hz). When this carry is generated between the reading of the low-order data and the high-order data, a content combining the two does not become the correct value (the low-order data is read as FFH and the high-order data becomes the value that is counted up 1 from that point).

The high-order data hold function in the S1C63558 is designed to operate to avoid this. This function temporarily stops the counting up of the high-order data (by carry from the low-order data) at the point where the low-order data has been read and consequently the time during which the high-order data is held is the shorter of the two indicated here following.

1. Period until it reads the high-order data.
2. 0.48–1.5 msec (Varies due to the read timing.)

Note: Since the low-order data is not held when the high-order data has previously been read, the low-order data should be read first.

4.8.3 Interrupt function

The clock timer can cause interrupts at the falling edge of 32 Hz, 8 Hz, 2 Hz and 1 Hz signals. Software can set whether to mask any of these frequencies.

Figure 4.8.3.1 is the timing chart of the clock timer.

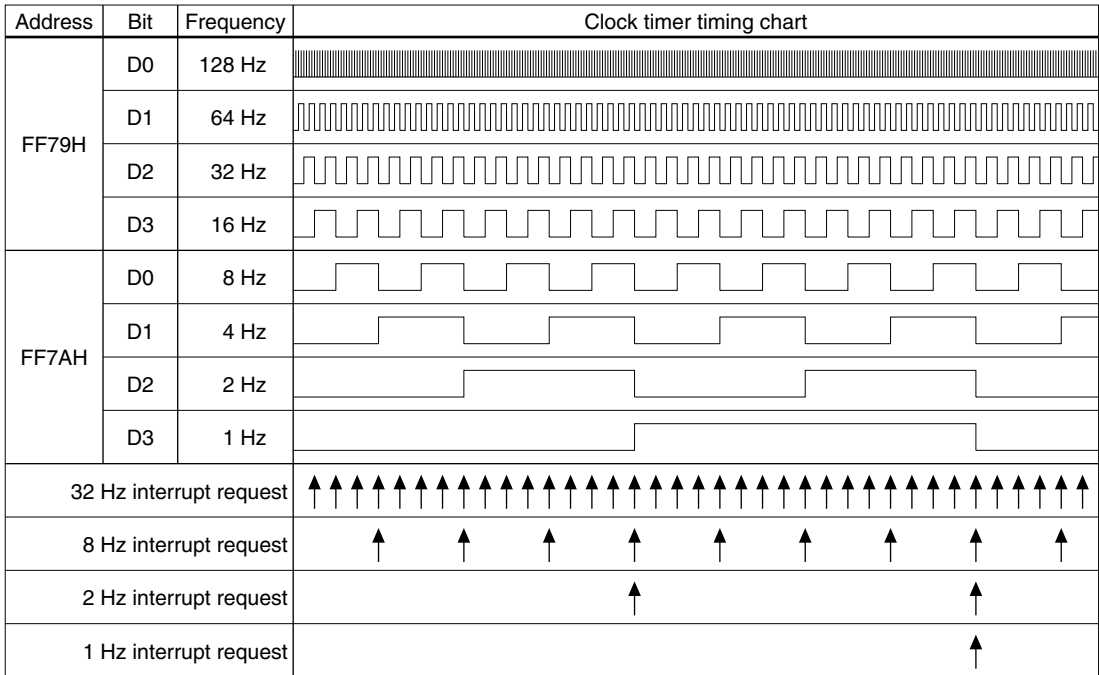

Fig. 4.8.3.1 Timing chart of clock timer

As shown in Figure 4.8.3.1, interrupt is generated at the falling edge of the frequencies (32 Hz, 8 Hz, 2 Hz, 1 Hz). At this time, the corresponding interrupt factor flag (IT0, IT1, IT2, IT3) is set to "1". Selection of whether to mask the separate interrupts can be made with the interrupt mask registers (EIT0, EIT1, EIT2, EIT3). However, regardless of the interrupt mask register setting, the interrupt factor flag is set to "1" at the falling edge of the corresponding signal.

4.8.4 I/O memory of clock timer

Table 4.8.4.1 shows the I/O addresses and the control bits for the clock timer.

Table 4.8.4.1 Control bits of clock timer

Address	Register				Name	Init #1	1	0	Comment
	D3	D2	D1	D0					
FF78H	0	0	TMRST	TMRUN	0 #3 - #2 0 #3 - #2				Unused Unused
	R		W	R/W	TMRST#3 TMRUN	Reset 0	Reset Run	Invalid Stop	Clock timer reset (writing) Clock timer Run/Stop
	TM3	TM2	TM1	TM0	TM3 TM2 TM1 TM0	0 0 0 0			Clock timer data (16 Hz) Clock timer data (32 Hz) Clock timer data (64 Hz) Clock timer data (128 Hz)
FF7AH	TM7	TM6	TM5	TM4	TM7 TM6 TM5 TM4	0 0 0 0			Clock timer data (1 Hz) Clock timer data (2 Hz) Clock timer data (4 Hz) Clock timer data (8 Hz)
	R								
	EIT3	EIT2	EIT1	EIT0	EIT3 EIT2 EIT1 EIT0	0 0 0 0	Enable Enable Enable Enable	Mask Mask Mask Mask	Interrupt mask register (Clock timer 1 Hz) Interrupt mask register (Clock timer 2 Hz) Interrupt mask register (Clock timer 8 Hz) Interrupt mask register (Clock timer 32 Hz)
FFE6H	IT3	IT2	IT1	IT0	IT3 IT2 IT1 IT0	0 0 0 0	(R) Yes (W) Reset	(R) No (W) Invalid	Interrupt factor flag (Clock timer 1 Hz) Interrupt factor flag (Clock timer 2 Hz) Interrupt factor flag (Clock timer 8 Hz) Interrupt factor flag (Clock timer 32 Hz)
	R/W								

*1 Initial value at initial reset

*2 Not set in the circuit

*3 Constantly "0" when being read

TM0–TM7: Timer data (FF79H, FF7AH)

The 128–1 Hz timer data of the clock timer can be read out with these registers. These eight bits are read only, and writing operations are invalid.

By reading the low-order data (FF79H), the high-order data (FF7AH) is held until reading or for 0.48–1.5 msec (one of shorter of them).

At initial reset, the timer data is initialized to "00H".

TMRST: Clock timer reset (FF78H•D1)

This bit resets the clock timer.

When "1" is written: Clock timer reset

When "0" is written: No operation

Reading: Always "0"

The clock timer is reset by writing "1" to TMRST. When the clock timer is reset in the RUN status, operation restarts immediately. Also, in the STOP status the reset data is maintained. No operation results when "0" is written to TMRST.

This bit is write-only, and so is always "0" at reading.

TMRUN: Clock timer RUN/STOP control register (FF78H•D0)

Controls RUN/STOP of the clock timer.

When "1" is written: RUN

When "0" is written: STOP

Reading: Valid

The clock timer enters the RUN status when "1" is written to the TMRUN register, and the STOP status when "0" is written. In the STOP status, the timer data is maintained until the next RUN status or the timer is reset. Also, when the STOP status changes to the RUN status, the data that is maintained can be used for resuming the count.

At initial reset, this register is set to "0".

EIT0: 32 Hz interrupt mask register (FFE6H•D0)

EIT1: 8 Hz interrupt mask register (FFE6H•D1)

EIT2: 2 Hz interrupt mask register (FFE6H•D2)

EIT3: 1 Hz interrupt mask register (FFE6H•D3)

These registers are used to select whether to mask the clock timer interrupt.

When "1" is written: Enabled

When "0" is written: Masked

Reading: Valid

The interrupt mask registers (EIT0, EIT1, EIT2, EIT3) are used to select whether to mask the interrupt to the separate frequencies (32 Hz, 8 Hz, 2 Hz, 1 Hz).

At initial reset, these registers are set to "0".

IT0: 32 Hz interrupt factor flag (FFF6H•D0)

IT1: 8 Hz interrupt factor flag (FFF6H•D1)

IT2: 2 Hz interrupt factor flag (FFF6H•D2)

IT3: 1 Hz interrupt factor flag (FFF6H•D3)

These flags indicate the status of the clock timer interrupt.

When "1" is read: Interrupt has occurred

When "0" is read: Interrupt has not occurred

When "1" is written: Flag is reset

When "0" is written: Invalid

The interrupt factor flags (IT0, IT1, IT2, IT3) correspond to the clock timer interrupts of the respective frequencies (32 Hz, 8 Hz, 2 Hz, 1 Hz). The software can judge from these flags whether there is a clock timer interrupt. However, even if the interrupt is masked, the flags are set to "1" at the falling edge of the signal.

These flags are reset to "0" by writing "1" to them.

After an interrupt occurs, the same interrupt will occur again if the interrupt enabled state (I flag = "1") is set or the RETI instruction is executed unless the interrupt factor flag is reset. Therefore, be sure to reset (write "1" to) the interrupt factor flag in the interrupt service routine before shifting to the interrupt enabled state.

At initial reset, these flags are set to "0".

4.8.5 Programming notes

- (1) Be sure to read timer data in the order of low-order data (TM0–TM3) then high-order data (TM4–TM7).
- (2) After an interrupt occurs, the same interrupt will occur again if the interrupt enabled state (I flag = "1") is set or the RETI instruction is executed unless the interrupt factor flag is reset. Therefore, be sure to reset (write "1" to) the interrupt factor flag in the interrupt service routine before shifting to the interrupt enabled state.

4.9 Stopwatch Timer

4.9.1 Configuration of stopwatch timer

The S1C63558 has 1/100 sec unit and 1/10 sec unit stopwatch timer built-in. The stopwatch timer is configured with a 2 levels 4-bit BCD counter which has an input clock approximating 100 Hz signal (signal divided from OSC1 to the closest 100 Hz) and data can be read in units of 4 bits by software. Figure 4.9.1.1 shows the configuration of the stopwatch timer.

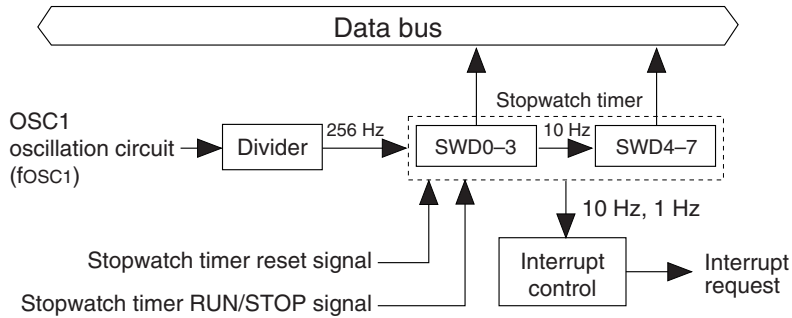

Fig. 4.9.1.1 Configuration of stopwatch timer

The stopwatch timer can be used as a separate timer from the clock timer. In particular, digital watch stopwatch functions can be realized easily with software.

4.9.2 Count-up pattern

The stopwatch timer is configured of 4-bit BCD counters SWD0–SWD3 and SWD4–SWD7. The counter SWD0–SWD3, at the stage preceding the stopwatch timer, has an approximated 100 Hz signal for the input clock. It counts up every 1/100 sec, and generates an approximated 10 Hz signal. The counter SWD4–SWD7 has an approximated 10 Hz signal generated by the counter SWD0–SWD3 for the input clock. In count-up every 1/10 sec, and generated 1 Hz signal.

Figure 4.9.2.1 shows the count-up pattern of the stopwatch timer.

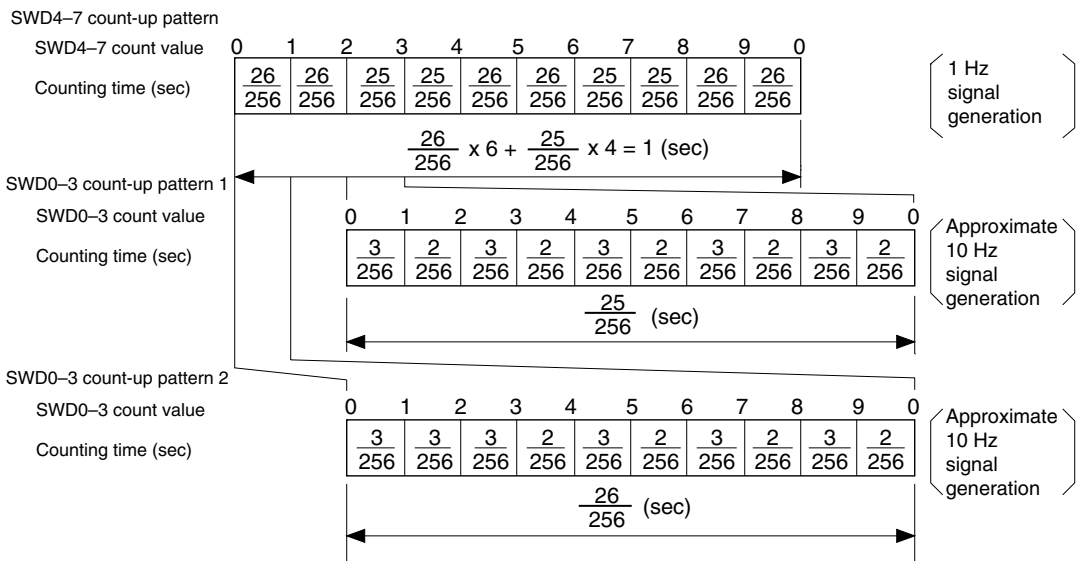

Fig. 4.9.2.1 Count-up pattern of stopwatch timer

SWD0–SWD3 generates an approximated 10 Hz signal from the basic 256 Hz signal (fOSC1 dividing clock). The count-up intervals are 2/256 sec and 3/256 sec, so that finally two patterns are generated: 25/256 sec and 26/256 sec intervals. Consequently, these patterns do not amount to an accurate 1/100 sec. SWD4–SWD7 counts the approximated 10 Hz signals generated by the 25/256 sec and 26/256 sec intervals in the ratio of 4 : 6, to generate a 1 Hz signal. The count-up intervals are 25/256 sec and 26/256 sec, which do not amount to an accurate 1/10 sec.

4.9.3 Interrupt function

The stopwatch timers SWD0–SWD3 and SWD4–SWD7, through their respective overflows, can generate 10 Hz (approximate 10 Hz) and 1 Hz interrupts.

Figure 4.9.3.1 shows the timing chart for the stopwatch timer.

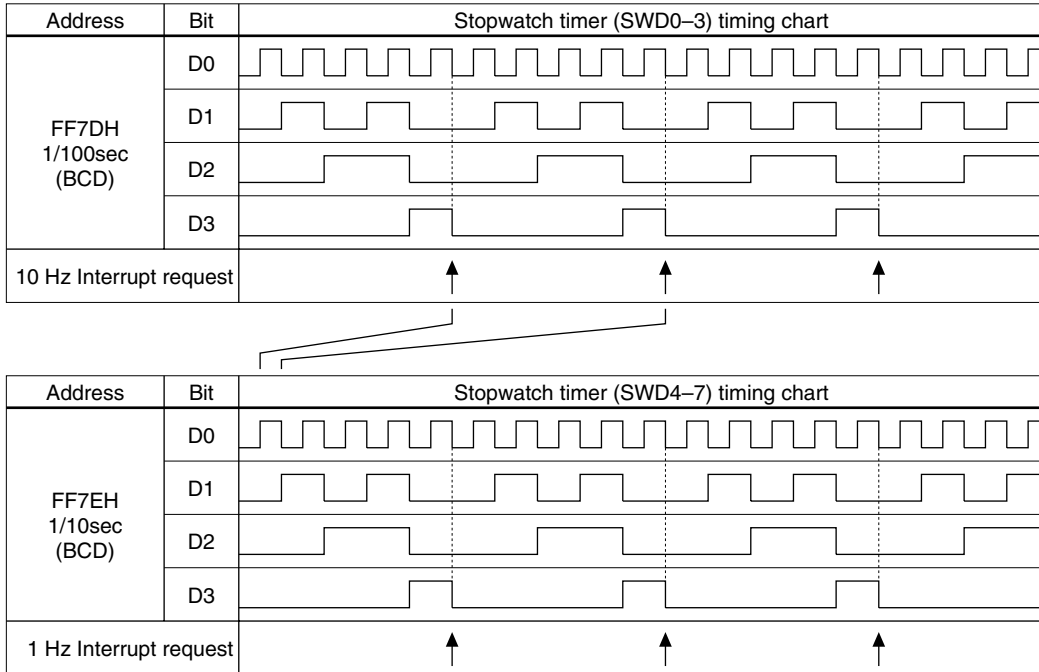

Fig. 4.9.3.1 Timing chart for stopwatch timer

The stopwatch interrupts are generated by the overflow of their respective counters SWD0–SWD3 and SWD4–SWD7 (changing "9" to "0"). At this time, the corresponding interrupt factor flags (ISW10 and ISW1) are set to "1".

The respective interrupts can be masked separately using the interrupt mask registers (EISW10 and EISW1). However, regardless of the setting of the interrupt mask registers, the interrupt factor flags are set to "1" by the overflow of their corresponding counters.

4.9.4 I/O memory of stopwatch timer

Table 4.9.4.1 shows the I/O addresses and the control bits for the stopwatch timer.

Table 4.9.4.1 Control bits of stopwatch timer

Address	Register								Comment
	D3	D2	D1	D0	Name	Init *1	1	0	
FF7CH	0	0	SWRST	SWRUN	0 *3	- *2			Unused
					0 *3	- *2			Unused
	R		W	R/W	SWRST*3	Reset	Reset	Invalid	Stopwatch timer reset (writing)
FF7DH	SWD3	SWD2	SWD1	SWD0	SWD3	0			Stopwatch timer data BCD (1/100 sec)
					SWD2	0			
	R				SWD1	0			
					SWD0	0			
FF7EH	SWD7	SWD6	SWD5	SWD4	SWD7	0			Stopwatch timer data BCD (1/10 sec)
					SWD6	0			
	R				SWD5	0			
					SWD4	0			
FFE7H	0	0	EISW1	EISW10	0 *3	- *2			Unused
					0 *3	- *2			Unused
	R		R/W		EISW1	0	Enable	Mask	Interrupt mask register (Stopwatch timer 1 Hz)
FFF7H	0	0	ISW1	ISW10	0 *3	- *2	(R)	(R)	Unused
					0 *3	- *2	Yes	No	Unused
	R		R/W		ISW1	0	(W)	(W)	Interrupt factor flag (Stopwatch timer 1 Hz)
				ISW10	0	Reset	Invalid	Interrupt factor flag (Stopwatch timer 10 Hz)	

*1 Initial value at initial reset

*2 Not set in the circuit

*3 Constantly "0" when being read

SWD0–SWD7: Stopwatch timer data (FF7DH, FF7EH)

The 1/100 sec and the 1/10 sec data (BCD) can be read from SWD0–SWD3 and SWD4–SWD7, respectively. These eight bits are read only, and writing operations are invalid.

At initial reset, the timer data is initialized to "00H".

SWRST: Stopwatch timer reset (FF7CH•D1)

When "1" is written: Stopwatch timer reset

When "0" is written: No operation

Reading: Always "0"

The stopwatch timer is reset by writing "1" to SWRST. All timer data is set to "0". When the stopwatch timer is reset in the RUN status, operation restarts immediately. Also, in the STOP status the reset data is maintained. No operation results when "0" is written to SWRST.

This bit is write-only, and so is always "0" at reading.

SWRUN: Stopwatch timer RUN/STOP control register (FF7CH•D0)

Controls RUN/STOP of the stopwatch timer.

When "1" is written: RUN

When "0" is written: STOP

Reading: Valid

The stopwatch timer enters the RUN status when "1" is written to the SWRUN register, and the STOP status when "0" is written.

In the STOP status, the timer data is maintained until the next RUN status or the timer is reset. Also, when the STOP status changes to the RUN status, the data that is maintained can be used for resuming the count.

When data of the counter is read at run mode, proper reading may not be obtained due to the carry from low-order digits (SWD0–SWD3) into high-order digits (SWD4–SWD7) (i.e., in case SWD0–SWD3 and SWD4–SWD7 reading span the timing of the carry). To avoid this occurrence, perform the reading after suspending the counter once and then set the SWRUN to "1" again.

Moreover, it is required that the suspension period not exceed 976 μ sec (1/4 cycle of 256 Hz).

At initial reset, this register is set to "0".

EISW10: 10Hz interrupt mask register (FFE7H•D0)

EISW1: 1Hz interrupt mask register (FFE7H•D1)

These registers are used to select whether to mask the stopwatch timer interrupt.

When "1" is written: Enabled

When "0" is written: Masked

Reading: Valid

The interrupt mask registers (EISW10, EISW1) are used to select whether to mask the interrupt to the separate frequencies (10 Hz, 1 Hz).

At initial reset, these registers are set to "0".

ISW10: 10 Hz interrupt factor flag (FFF7H•D0)

ISW1: 1 Hz interrupt factor flag (FFF7H•D1)

These flags indicate the status of the stopwatch timer interrupt.

When "1" is read: Interrupt has occurred

When "0" is read: Interrupt has not occurred

When "1" is written: Flag is reset

When "0" is written: Invalid

The interrupt factor flags ISW10 and ISW1 correspond to 10 Hz and 1 Hz stopwatch timer interrupts, respectively. The software can judge from these flags whether there is a stopwatch timer interrupt.

However, even if the interrupt is masked, the flags are set to "1" by the overflow of the corresponding counters.

These flags are reset to "0" by writing "1" to them.

After an interrupt occurs, the same interrupt will occur again if the interrupt enabled state (I flag = "1") is set or the RETI instruction is executed unless the interrupt factor flag is reset. Therefore, be sure to reset (write "1" to) the interrupt factor flag in the interrupt service routine before shifting to the interrupt enabled state.

At initial reset, these flags are set to "0".

4.9.5 Programming notes

- (1) When data of the counter is read at run mode, perform the reading after suspending the counter once and then set SWRUN to "1" again. Moreover, it is required that the suspension period not exceed 976 μ sec (1/4 cycle of 256 Hz).
- (2) After an interrupt occurs, the same interrupt will occur again if the interrupt enabled state (I flag = "1") is set or the RETI instruction is executed unless the interrupt factor flag is reset. Therefore, be sure to reset (write "1" to) the interrupt factor flag in the interrupt service routine before shifting to the interrupt enabled state.

4.10 Programmable Timer

4.10.1 Configuration of programmable timer

The S1C63558 has two 8-bit programmable timer systems (timer 0 and timer 1) built-in.

Timer 0 and timer 1 are composed of 8-bit presettable down counters and they can be used as 8-bit × 2 channel programmable timers. Timer 0 also has an event counter function using the K13 input port terminal.

Figure 4.10.1.1 shows the configuration of the programmable timer.

The programmable timer is designed to count down from the initial value set in the counter with software. An underflow according to the initial value occurs by counting down and is used for the following functions:

- Presetting the initial value to the counter to generate the periodical underflow signal
- Generating an interrupt
- Generating a TOUT signal output from the R02 output port terminal
- Generating the synchronous clock source for the serial interface (timer 1 underflow is used, and it is possible to set the transfer rate)

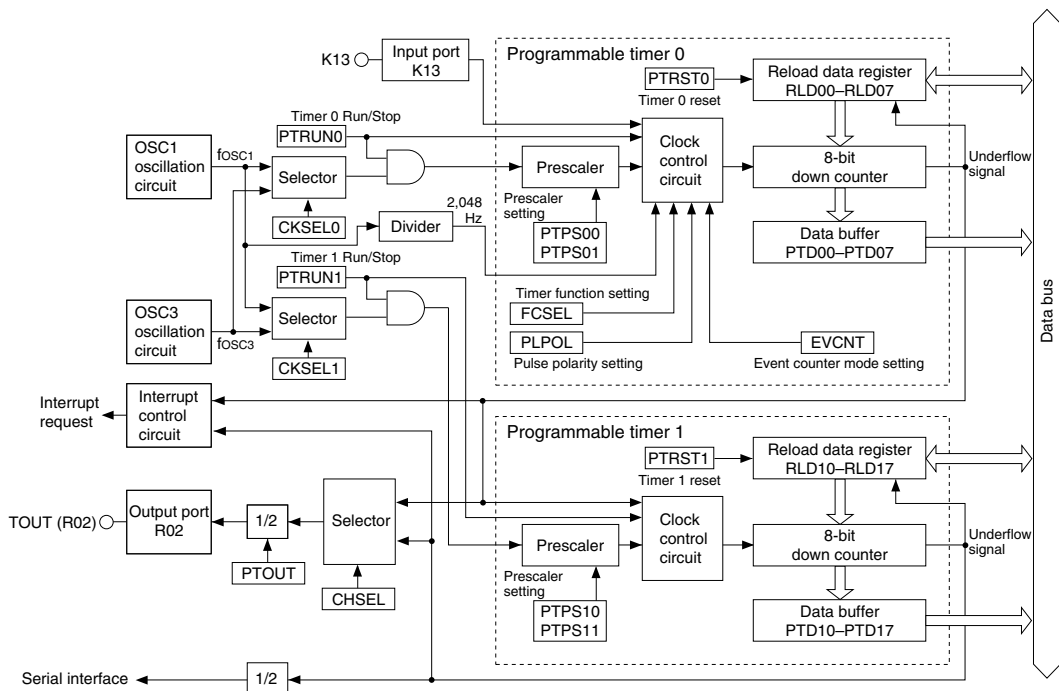

Fig. 4.10.1.1 Configuration of programmable timer

4.10.2 Setting of initial value and counting down

Timers 0 and 1 each have a down counter and reload data register.

The reload data registers RLD00–RLD07 (timer 0) and RLD10–RLD17 (timer 1) are used to set the initial value to the down counter.

By writing "1" to the timer reset bit PTRST0 (timer 0) or PTRST1 (timer 1), the down counter loads the initial value set in the reload register RLD. Therefore, down-counting is executed from the stored initial value by the input clock.

The registers PTRUN0 (timer 0) and PTRUN1 (timer 1) are provided to control the RUN/STOP for timers 0 and 1. By writing "1" to the register after presetting the reload data to the down counter, the down counter starts counting down. Writing "0" stops the input count clock and the down counter stops counting. This control (RUN/STOP) does not affect the counter data. The counter maintains its data while stopped, and can restart counting continuing from that data.

The counter data can be read via the data buffers PTD00–PTD07 (timer 0) and PTD10–PTD17 (timer 1) in optional timing. However, the counter has the data hold function the same as the clock timer, that holds the high-order data when the low-order data is read in order to prevent the borrowing operation between low- and high-order reading, therefore be sure to read the low-order data first.

The counter reloads the initial value set in the reload data register RLD when an underflow occurs through the count down. It continues counting down from the initial value after reloading.

In addition to reloading the counter, this underflow signal controls the interrupt generation, pulse (TOUT signal) output and clock supplying to the serial interface.

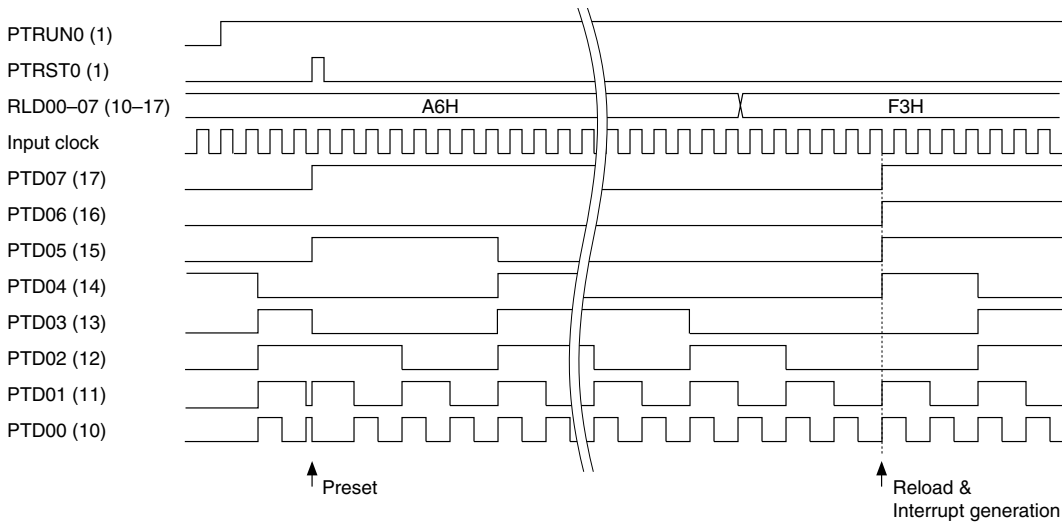

Fig. 4.10.2.1 Basic operation timing of down counter

4.10.3 Counter mode

The programmable timer can operate in two counter modes, timer mode and event counter mode. It can be selected by software.

(1) Timer mode

The timer mode counts down using the prescaler output as an input clock. In this mode, the programmable timer operates as a periodical timer using the OSC1 or OSC3 oscillation clock as a clock source. Timer 0 can operate in both the timer mode and the event counter mode. The mode can be switched using the timer 0 counter mode selection register EVCNT. When the EVCNT register is set to "0", timer 0 operates in the timer mode.

Timer 1 operates only in the timer mode.

At initial reset, this mode is set.

Refer to Section 4.10.2, "Setting of initial value and counting down" for basic operation and control.

The input clock in the timer mode is generated by the prescaler built into the programmable timer. The prescaler generates the input clock by dividing the OSC1 or OSC3 oscillation clock. Refer to the next section for setting the input clock.

(2) Event counter mode

The timer 0 has an event counter function that counts an external clock input to the input port K13. This function is selected by writing "1" to the timer 0 counter mode selection register EVCNT. The timer 1 operates only in the timer mode, and cannot be used as an event counter.

In the event counter mode, the clock is supplied to timer 0 from outside of the IC, therefore, the settings of the timer 0 prescaler division ratio selection registers PTPS00 and PTPS01 and the settings of the timer 0 source clock selection register CKSEL0 become invalid.

Count down timing can be selected from either the falling or rising edge of the input clock using the timer 0 pulse polarity selection register PLPOL. When "0" is written to the PLPOL register, the falling edge is selected, and when "1" is written, the rising edge is selected. The count down timing is shown in Figure 4.10.3.1.

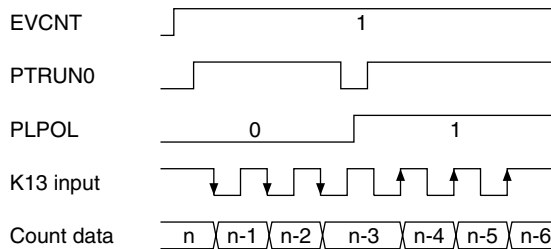

Fig. 4.10.3.1 Timing chart in event counter mode

The event counter mode also includes a noise reject function to eliminate noise such as chattering on the external clock (K13 input signal). This function is selected by writing "1" to the timer 0 function selection register FCSSEL.

When "with noise rejector" is selected, an input pulse width for both low and high levels must be 0.98 msec* or more to count reliably. The noise rejecter allows the counter to input the clock at the second falling edge of the internal 2,048 Hz* signal after changing the input level of the K13 input port terminal. Consequently, the pulse width of noise that can reliably be rejected is 0.48 msec* or less. (*: $f_{OSC1} = 32.768 \text{ kHz}$).

Figure 4.10.3.2 shows the count down timing with noise rejecter.

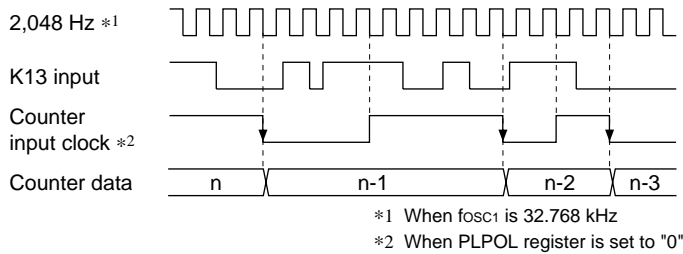

Fig. 4.10.3.2 Count down timing with noise rejecter

The operation of the event counter mode is the same as the timer mode except it uses the K13 input as the clock.

Refer to Section 4.10.2, "Setting of initial value and counting down" for basic operation and control.

4.10.4 Setting of input clock in timer mode

Timer 0 and timer 1 each include a prescaler. The prescalers generate the input clock for each timer by dividing the source clock supplied from the OSC1 or OSC3 oscillation circuit.

The source clock (OSC1 or OSC3) and the division ratio of the prescaler can be selected with software for timer 0 and timer 1 individually.

The set input clock is used for the count clock during operation in the timer mode. When the timer 0 is used in the event counter mode, the following settings become invalid.

The input clock is set in the following sequence.

(1) Selection of source clock

Select the source clock input to each prescaler from either OSC1 or OSC3. This selection is done using the source clock selection registers CKSEL0 (timer 0) and CKSEL1 (timer 1); when "0" is written to the register, OSC1 is selected and when "1" is written, OSC3 is selected.

When the OSC3 oscillation clock is selected for the clock source, it is necessary to turn the OSC3 oscillation ON, prior to using the programmable timer. However the OSC3 oscillation circuit requires a time at least 5 msec from turning the circuit ON until the oscillation stabilizes. Therefore, allow an adequate interval from turning the OSC3 oscillation circuit ON to starting the programmable timer. Refer to Section 4.3, "Oscillation Circuit", for the control and notes of the OSC3 oscillation circuit. At initial reset, the OSC3 oscillation circuit is set in the OFF state.

(2) Selection of prescaler division ratio

Select the division ratio for each prescaler from among 4 types. This selection is done using the prescaler division ratio selection registers PTPS00/PTPS01 (timer 0) and PTPS10/PTPS11 (timer 1). Table 4.10.4.1 shows the correspondence between the setting value and the division ratio.

Table 4.10.4.1 Selection of prescaler division ratio

PTPS11 PTPS01	PTPS10 PTPS00	Prescaler division ratio
1	1	Source clock / 256
1	0	Source clock / 32
0	1	Source clock / 4
0	0	Source clock / 1

By writing "1" to the register PTRUN0 (timer 0) or PTRUN1 (timer 1), the prescaler inputs the source clock and outputs the clock divided by the selected division ratio. The counter starts counting down by inputting the clock.

4.10.5 Interrupt function

The programmable timer can generate an interrupt due to an underflow of the timer 0 and timer 1. See Figure 4.10.2.1 for the interrupt timing.

An underflow of timer 0 and timer 1 sets the corresponding interrupt factor flag IPT0 (timer 0) or IPT1 (timer 1) to "1", and generates an interrupt. The interrupt can also be masked by setting the corresponding interrupt mask register EIPT0 (timer 0) or EIPT1 (timer 1). However, the interrupt factor flag is set to "1" by an underflow of the corresponding timer regardless of the interrupt mask register setting.

4.10.6 Setting of TOUT output

The programmable timer can generate a TOUT signal due to an underflow of timer 0 or timer 1. The TOUT signal is generated by dividing the underflows in 1/2. It is possible to select which timer's underflow is to be used by the TOUT output channel selection register CHSEL. When "0" is written to the CHSEL register, timer 0 is selected and when "1" is written, timer 1 is selected.

Figure 4.10.6.1 shows the TOUT signal waveform when the channel is changed.

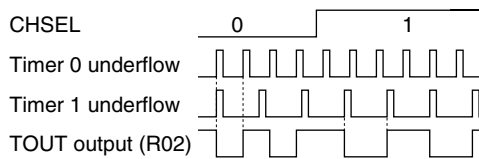

Fig. 4.10.6.1 TOUT signal waveform at channel change

The TOUT signal can be output from the R02 output port terminal. Programmable clocks can be supplied to external devices.

Figure 4.10.6.2 shows the configuration of the output port R02.

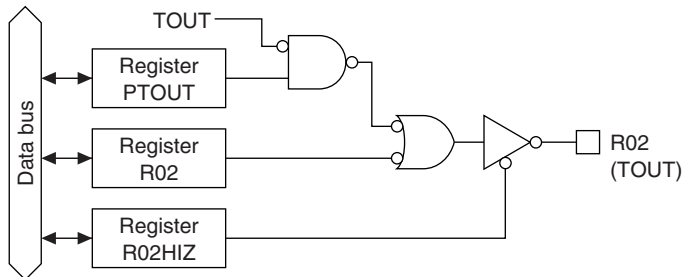

Fig. 4.10.6.2 Configuration of R02

The output of a TOUT signal is controlled by the PTOUT register. When "1" is written to the PTOUT register, the TOUT signal is output from the R02 output port terminal and when "0" is written, the terminal goes to a high (VDD) level. However, the data register R02 must always be "1" and the high impedance control register R02HIZ must always be "0" (data output state).

Since the TOUT signal is generated asynchronously from the PTOUT register, a hazard within 1/2 cycle is generated when the signal is turned ON and OFF by setting the register.

Figure 4.10.6.3 shows the output waveform of the TOUT signal.

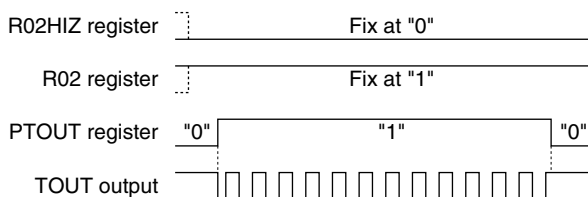

Fig. 4.10.6.3 Output waveform of the TOUT signal

4.10.7 Transfer rate setting for serial interface

The signal that is made from underflows of timer 1 by dividing them in 1/2, can be used as the clock source for the serial interface.

The programmable timer outputs the clock to the serial interface by setting timer 1 into RUN state (PTRUN = "1"). It is not necessary to control with the PTOUT register.

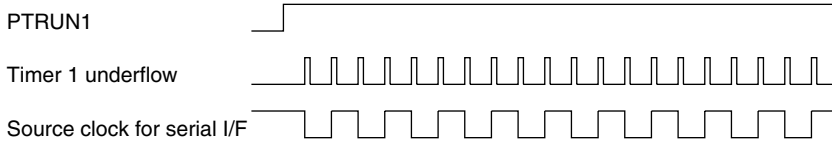

Fig. 4.10.7.1 Synchronous clock of serial interface

A setting value for the RLD1X register according to a transfer rate is calculated by the following expression:

$$RLD1X = f_{osc} / (32 * bps * \text{division ratio of the prescaler}) - 1$$

f_{osc}: Oscillation frequency (OSC1/OSC3)

bps: Transfer rate

(00H can be set to RLD1X)

Be aware that the maximum clock frequency for the serial interface is limited to 1 MHz when OSC3 is used as the clock source.

4.10.8 I/O memory of programmable timer

Table 4.10.8.1 shows the I/O addresses and the control bits for the programmable timer.

Table 4.10.8.1 Control bits of programmable timer

Address	Register				Name	Init *1	1	0	Comment
	D3	D2	D1	D0					
FFC0H	0	EVCNT	FCSEL	PLPOL	EVCNT 0 *3	- *2			Unused
	R	R/W			EVCNT	0	Event ct.	Timer	Timer 0 counter mode selection
		R/W			FCSEL	0	With NR	No NR	Timer 0 function selection (for event counter mode)
		R/W			PLPOL	0	↑	↓	Timer 0 pulse polarity selection (for event counter mode)
FFC1H	CHSEL	PTOUT	CKSEL1	CKSEL0	CHSEL	0	Timer1	Timer0	TOUT output channel selection
	R/W				PTOUT	0	On	Off	TOUT output control
	R/W				CKSEL1	0	OSC3	OSC1	Prescaler 1 source clock selection
	R/W				CKSEL0	0	OSC3	OSC1	Prescaler 0 source clock selection
FFC2H	PTPS01	PTPS00	PTRST0	PTRUN0	PTPS01	0			Prescaler 0 division ratio selection Division ratio 1/1 1/4 1/32 1/256
	R/W		W	R/W	PTPS00	0			
	R/W		W	R/W	PTRST0*3	- *2	Reset	Invalid	Timer 0 reset (reload)
	R/W		W	R/W	PTRUN0	0	Run	Stop	Timer 0 Run/Stop
FFC3H	PTPS11	PTPS10	PTRST1	PTRUN1	PTPS11	0			Prescaler 1 division ratio selection Division ratio 1/1 1/4 1/32 1/256
	R/W		W	R/W	PTPS10	0			
	R/W		W	R/W	PTRST1*3	- *2	Reset	Invalid	Timer 1 reset (reload)
	R/W		W	R/W	PTRUN1	0	Run	Stop	Timer 1 Run/Stop
FFC4H	RLD03	RLD02	RLD01	RLD00	RLD03	0			MSB
	R/W				RLD02	0			
	R/W				RLD01	0			Programmable timer 0 reload data (low-order 4 bits)
	R/W				RLD00	0			
FFC5H	RLD07	RLD06	RLD05	RLD04	RLD07	0			MSB
	R/W				RLD06	0			
	R/W				RLD05	0			Programmable timer 0 reload data (high-order 4 bits)
	R/W				RLD04	0			
FFC6H	RLD13	RLD12	RLD11	RLD10	RLD13	0			MSB
	R/W				RLD12	0			
	R/W				RLD11	0			Programmable timer 1 reload data (low-order 4 bits)
	R/W				RLD10	0			
FFC7H	RLD17	RLD16	RLD15	RLD14	RLD17	0			MSB
	R/W				RLD16	0			
	R/W				RLD15	0			Programmable timer 1 reload data (high-order 4 bits)
	R/W				RLD14	0			
FFC8H	PTD03	PTD02	PTD01	PTD00	PTD03	0			MSB
	R				PTD02	0			
	R				PTD01	0			Programmable timer 0 data (low-order 4 bits)
	R				PTD00	0			
FFC9H	PTD07	PTD06	PTD05	PTD04	PTD07	0			MSB
	R				PTD06	0			
	R				PTD05	0			Programmable timer 0 data (high-order 4 bits)
	R				PTD04	0			
FFCAH	PTD13	PTD12	PTD11	PTD10	PTD13	0			MSB
	R				PTD12	0			
	R				PTD11	0			Programmable timer 1 data (low-order 4 bits)
	R				PTD10	0			
FFCBH	PTD17	PTD16	PTD15	PTD14	PTD17	0			MSB
	R				PTD16	0			
	R				PTD15	0			Programmable timer 1 data (high-order 4 bits)
	R				PTD14	0			
FFE2H	0	0	EIPT1	EIPT0	0 *3	- *2			Unused
	R		R/W		0 *3	- *2			Unused
	R		R/W		EIPT1	0	Enable	Mask	Interrupt mask register (Programmable timer 1)
	R		R/W		EIPT0	0	Enable	Mask	Interrupt mask register (Programmable timer 0)
FFF2H	0	0	IPT1	IPT0	0 *3	- *2	(R)	(R)	Unused
	R		R/W		0 *3	- *2	Yes	No	Unused
	R		R/W		IPT1	0	(W)	(W)	Interrupt factor flag (Programmable timer 1)
	R		R/W		IPT0	0	Reset	Invalid	Interrupt factor flag (Programmable timer 0)

*1 Initial value at initial reset

*2 Not set in the circuit

*3 Constantly "0" when being read

CKSEL0: Prescaler 0 source clock selection register (FFC1H•D0)

CKSEL1: Prescaler 1 source clock selection register (FFC1H•D1)

Selects the source clock of the prescaler.

- When "1" is written: OSC3 clock
- When "0" is written: OSC1 clock
- Reading: Valid

The source clock for the prescaler is selected from OSC1 or OSC3. When "0" is written to the CKSEL0 register, the OSC1 clock is selected as the input clock for the prescaler 0 (for timer 0) and when "1" is written, the OSC3 clock is selected.

Same as above, the source clock for prescaler 1 is selected by the CKSEL1 register.

When the event counter mode is selected to timer 0, the setting of the CKSEL0 register becomes invalid. At initial reset, these registers are set to "0".

PTPS00, PTPS01: Timer 0 prescaler division ratio selection register (FFC2H•D2, D3)

PTPS10, PTPS11: Timer 1 prescaler division ratio selection register (FFC3H•D2, D3)

Selects the division ratio of the prescaler.

Two bits of PTPS00 and PTPS01 are the prescaler division ratio selection register for timer 0, and two bits of PTPS10 and PTPS11 are for timer 1. The prescaler division ratios that can be set by these registers are shown in Table 4.10.8.2.

Table 4.10.8.2 Selection of prescaler division ratio

PTPS11 PTPS01	PTPS10 PTPS00	Prescaler division ratio
1	1	Source clock / 256
1	0	Source clock / 32
0	1	Source clock / 4
0	0	Source clock / 1

When the event counter mode is selected to timer 0, the setting of the PTPS00 and PTPS01 becomes invalid.

At initial reset, these registers are set to "0".

EVCNT: Timer 0 counter mode selection register (FFC0H•D2)

Selects a counter mode for timer 0.

- When "1" is written: Event counter mode
- When "0" is written: Timer mode
- Reading: Valid

The counter mode for timer 0 is selected from either the event counter mode or timer mode. When "1" is written to the EVCNT register, the event counter mode is selected and when "0" is written, the timer mode is selected.

At initial reset, this register is set to "0".

FCSEL: Timer 0 function selection register (FFC0H•D1)

Selects whether the noise rejector of the clock input circuit will be used or not in the event counter mode.

When "1" is written: With noise rejector

When "0" is written: Without noise rejector

Reading: Valid

When "1" is written to the FCSEL register, the noise rejector is used and counting is done by an external clock (K13) with 0.98 msec* or more pulse width. The noise rejector allows the counter to input the clock at the second falling edge of the internal 2,048 Hz* signal after changing the input level of the K13 input port terminal. Consequently, the pulse width of noise that can reliably be rejected is 0.48 msec* or less. (*: fOSC1 = 32.768 kHz).

When "0" is written to the FCSEL register, the noise rejector is not used and the counting is done directly by an external clock input to the K13 input port terminal.

Setting of this register is effective only when timer 0 is used in the event counter mode.

At initial reset, this register is set to "0".

PLPOL: Timer 0 pulse polarity selection register (FFC0H•D0)

Selects the count pulse polarity in the event counter mode.

When "1" is written: Rising edge

When "0" is written: Falling edge

Reading: Valid

The count timing in the event counter mode (timer 0) is selected from either the falling edge of the external clock input to the K13 input port terminal or the rising edge. When "0" is written to the PLPOL register, the falling edge is selected and when "1" is written, the rising edge is selected.

Setting of this register is effective only when timer 0 is used in the event counter mode.

At initial reset, this register is set to "0".

RLD00–RLD07: Timer 0 reload data register (FFC4H, FFC5H)**RLD10–RLD17: Timer 1 reload data register (FFC6H, FFC7H)**

Sets the initial value for the counter.

The reload data written in this register is loaded to the respective counters. The counter counts down using the data as the initial value for counting.

Reload data is loaded to the counter when the counter is reset by writing "1" to the PTRST0 or PTRST1 register, or when counter underflow occurs.

At initial reset, these registers are set to "00H".

PTD00–PTD07: Timer 0 counter data (FFC8H, FFC9H)**PTD10–PTD17: Timer 1 counter data (FFCAH, FFCBH)**

Count data in the programmable timer can be read from these latches.

The low-order 4 bits of the count data in timer 0 can be read from PTD00–PTD03, and the high-order data can be read from PTD04–PTD07. Similarly, for timer 1, the low-order 4 bits can be read from PTD10–PTD13, and the high-order data can be read from PTD14–PTD17.

Since the high-order 4 bits are held by reading the low-order 4 bits, be sure to read the low-order 4 bits first.

Since these latches are exclusively for reading, the writing operation is invalid.

At initial reset, these counter data are set to "00H".

PTRST0: Timer 0 reset (reload) (FFC2H•D1)

PTRST1: Timer 1 reset (reload) (FFC3H•D1)

Resets the timer and presets reload data to the counter.

When "1" is written: Reset
When "0" is written: No operation
Reading: Always "0"

By writing "1" to PTRST0, the reload data in the reload register PLD00–PLD07 is preset to the counter in timer 0. Similarly, the reload data in PLD10–PLD17 is preset to the counter in timer 1 by PTRST1.

When the counter is preset in the RUN status, the counter restarts immediately after presetting. In the case of STOP status, the reload data is preset to the counter and is maintained.

No operation results when "0" is written.

Since these bits are exclusively for writing, always set to "0" during reading.

PTRUN0: Timer 0 RUN/STOP control register (FFC2H•D0)

PTRUN1: Timer 1 RUN/STOP control register (FFC3H•D0)

Controls the RUN/STOP of the counter.

When "1" is written: RUN
When "0" is written: STOP
Reading: Valid

The counter in timer 0 starts counting down by writing "1" to the PTRUN0 register and stops by writing "0".

In STOP status, the counter data is maintained until the counter is reset or is set in the next RUN status. When STOP status changes to RUN status, the data that has been maintained can be used for resuming the count.

Same as above, the timer 1 counter is controlled by the PTRUN1 register.

At initial reset, these registers are set to "0".

CHSEL: TOUT output channel selection register (FFC1H•D3)

Selects the channel used for TOUT signal output.

When "1" is written: Timer 1
When "0" is written: Timer 0
Reading: Valid

This register selects which timer's underflow (timer 0 or timer 1) is used to generate a TOUT signal. When "0" is written to the CHSEL register, timer 0 is selected and when "1" is written, timer 1 is selected.

At initial reset, this register is set to "0".

PTOUT: TOUT output control register (FFC1H•D2)

Turns TOUT signal output ON and OFF.

When "1" is written: ON
When "0" is written: OFF
Reading: Valid

PTOUT is the output control register for the TOUT signal. When "1" is written to the register, the TOUT signal is output from the output port terminal R02 and when "0" is written, the terminal goes to a high (VDD) level. However, the data register R02 must always be "1" and the high impedance control register R02HIZ must always be "0" (data output state).

At initial reset, this register is set to "0".

EIPT0: Timer 0 interrupt mask register (FFE2H•D0)**EIPT1: Timer 1 interrupt mask register (FFE2H•D1)**

These registers are used to select whether to mask the programmable timer interrupt or not.

When "1" is written: Enabled

When "0" is written: Masked

Reading: Valid

Timer 0 and timer 1 interrupts can be masked individually by the interrupt mask registers EIPT0 (timer 0) and EIPT1 (timer 1).

At initial reset, these registers are set to "0".

IPT0: Timer 0 interrupt factor flag (FFF2H•D0)**IPT1: Timer 1 interrupt factor flag (FFF2H•D1)**

These flags indicate the status of the programmable timer interrupt.

When "1" is read: Interrupt has occurred

When "0" is read: Interrupt has not occurred

When "1" is written: Flag is reset

When "0" is written: Invalid

The interrupt factor flags IPT0 and IPT1 correspond to timer 0 and timer 1 interrupts, respectively. The software can judge from these flags whether there is a programmable timer interrupt. However, even if the interrupt is masked, the flags are set to "1" by the underflows of the corresponding counters.

These flags are reset to "0" by writing "1" to them.

After an interrupt occurs, the same interrupt will occur again if the interrupt enabled state (I flag = "1") is set or the RETI instruction is executed unless the interrupt factor flag is reset. Therefore, be sure to reset (write "1" to) the interrupt factor flag in the interrupt service routine before shifting to the interrupt enabled state.

At initial reset, these flags are set to "0".

4.10.9 Programming notes

- (1) When reading counter data, be sure to read the low-order 4 bits (PTD00–PTD03, PTD10–PTD13) first. Furthermore, the high-order 4 bits (PTD04–PTD07, PTD14–PTD17) should be read within 0.73 msec (when fOSC1 is 32.768 kHz) of reading the low-order 4 bits (PTD00–PTD03, PTD10–PTD13).
- (2) The programmable timer actually enters RUN/STOP status in synchronization with the falling edge of the input clock after writing to the PTRUN0/PTRUN1 register. Consequently, when "0" is written to the PTRUN0/PTRUN1 register, the timer enters STOP status at the point where the counter is decremented (-1). The PTRUN0/PTRUN1 register maintains "1" for reading until the timer actually stops.

Figure 4.10.9.1 shows the timing chart for the RUN/STOP control.

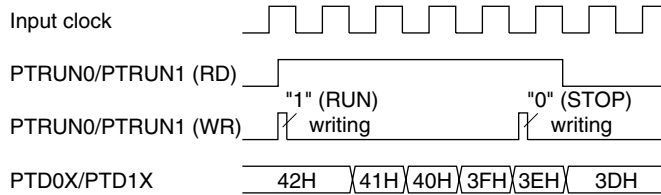

Fig. 4.10.9.1 Timing chart for RUN/STOP control

It is the same even in the event counter mode. Therefore, be aware that the counter does not enter RUN/STOP status if a clock is not input after setting the RUN/STOP control register (PTRUN0).

- (3) Since the TOUT signal is generated asynchronously from the PTOUT register, a hazard within 1/2 cycle is generated when the signal is turned ON and OFF by setting the register.
- (4) When the OSC3 oscillation clock is selected for the clock source, it is necessary to turn the OSC3 oscillation ON, prior to using the programmable timer. However the OSC3 oscillation circuit requires a time at least 5 msec from turning the circuit ON until the oscillation stabilizes. Therefore, allow an adequate interval from turning the OSC3 oscillation circuit ON to starting the programmable timer. Refer to Section 4.3, "Oscillation Circuit", for the control and notes of the OSC3 oscillation circuit. At initial reset, the OSC3 oscillation circuit is set in the OFF state.
- (5) After an interrupt occurs, the same interrupt will occur again if the interrupt enabled state (I flag = "1") is set or the RETI instruction is executed unless the interrupt factor flag is reset. Therefore, be sure to reset (write "1" to) the interrupt factor flag in the interrupt service routine before shifting to the interrupt enabled state.

4.11 Serial Interface

4.11.1 Configuration of serial interface

The S1C63558 incorporates 2 channels (SIF (1), SIF (2)) of full duplex serial interface circuits (when asynchronous system is selected) that allows the user to select either clock synchronous system or asynchronous system.

The data transfer method can be selected in software.

When the clock synchronous system is selected, 8-bit data transfer is possible.

When the asynchronous system is selected, either 7-bit or 8-bit data transfer is possible, and a parity check of received data and the addition of a parity bit for transmitting data can automatically be done by selecting in software.

Differences between SIF (1) and SIF (2)

SIF (1) and SIF (2) are independently separated serial interface blocks that have the same functions and circuit configurations. The serial I/O terminals and control registers are assigned as follows:

Serial I/O terminals: SIF (1) → P10–P13

SIF (2) → P30–P33

Control register addresses: SIF (1) → FF70H–FF75H, FFE3H, FFF3H

SIF (2) → FF58H–FF5DH, FFE8H, FFF8H

To distinguish the control bits of SIF (1) from SIF (2), "S" is added to the end of the name for the SIF (2) control bits.

Example: SIF (1) → ESIF, SIF (2) → ESIFS

When using the FSK demodulator, SIF (2) is used for data input. SIF (1) cannot be used for this purpose.

Note: Explanation made in this section is only for SIF (1). Be aware that "S" for the SIF (2) control bits is omitted. Further, the serial I/O terminal names are explained using P10–P13.

Figure 4.11.1.1 shows the configuration of the serial interface (1). The serial interface (2) has the same configuration except for the terminals.

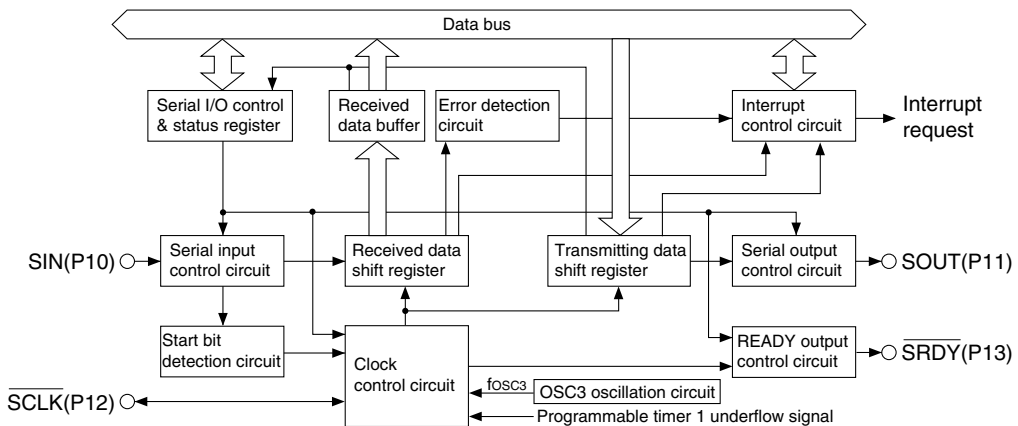

Fig. 4.11.1.1 Configuration of serial interface

Serial interface input/output terminals, SIN, SOUT, $\overline{\text{SCLK}}$ and $\overline{\text{SRDY}}$ are shared with the I/O ports P10–P13. In order to utilize these terminals for the serial interface input/output terminals, proper settings have to be made with registers ESIF, SMD0 and SMD1. (At initial reset, these terminals are set as I/O port terminals.)

The direction of I/O port terminals set for serial interface input/output terminals are determined by the signal and transfer mode for each terminal. Furthermore, the settings for the corresponding I/O control registers for the I/O ports become invalid.

Table 4.11.1.1 Configuration of input/output terminals

Terminal	When serial interface is selected
P10	SIN
P11	SOUT
P12	$\overline{\text{SCLK}}$
P13	$\overline{\text{SRDY}}$

* The terminals used may vary depending on the transfer mode.

SIN and SOUT are serial data input and output terminals which function identically in clock synchronous system and asynchronous system. $\overline{\text{SCLK}}$ is exclusively for use with clock synchronous system and functions as a synchronous clock input/output terminal. $\overline{\text{SRDY}}$ is exclusively for use in clock synchronous slave mode and functions as a send-receive ready signal output terminal.

When asynchronous system is selected, since $\overline{\text{SCLK}}$ and $\overline{\text{SRDY}}$ are superfluous, the I/O port terminals P12 and P13 can be used as I/O ports.

In the same way, when clock synchronous master mode is selected, since $\overline{\text{SRDY}}$ is superfluous, the I/O port terminal P13 can be used as I/O port.

4.11.2 Mask option

Since the input/output terminals of the serial interface is shared with the I/O ports (P10–P13), the mask option that selects the output specification for the I/O port is also applied to the serial interface.

The output specification of the terminals SOUT, $\overline{\text{SCLK}}$ (for clock synchronous master mode) and $\overline{\text{SRDY}}$ (for clock synchronous slave mode) that are used as output in the input/output port of the serial interface is respectively selected by the mask options of P11, P12 and P13. Either complementary output or N-channel open drain output can be selected as the output specification. However, when N-channel open drain output is selected, do not apply a voltage exceeding the power supply voltage to the terminal.

Furthermore, the pull-up resistor for the SIN terminal and the $\overline{\text{SCLK}}$ terminal (for clock synchronous slave mode) that are used as input terminals can be selected by the mask options of P10 and P12.

When "without pull-up" is selected, take care that the floating status does not occur.

4.11.3 Transfer modes

There are four transfer modes for the serial interface and mode selection is made by setting the two bits of the mode selection registers SMD0 and SMD1 as shown in the table below.

Table 4.11.3.1 Transfer modes

SMD1/SMD1S	SMD0/SMD0S	Mode
1	1	8-bit asynchronous
1	0	7-bit asynchronous
0	1	Clock synchronous slave
0	0	Clock synchronous master

Table 4.11.3.2 Terminal settings corresponding to each transfer mode

Mode	SIN	SOUT	$\overline{\text{SCLK}}$	$\overline{\text{SRDY}}$
Asynchronous 8-bit	Input	Output	P12	P13
Asynchronous 7-bit	Input	Output	P12	P13
Clock synchronous slave	Input	Output	Input	Output
Clock synchronous master	Input	Output	Output	P13

At initial reset, transfer mode is set to clock synchronous master mode.

Clock synchronous master mode

In this mode, the internal clock is utilized as a synchronous clock for the built-in shift registers, and 8-bit clock synchronous serial transfers can be performed with this serial interface as the master. The synchronous clock is also output from the $\overline{\text{SCLK}}$ terminal which enables control of the external (slave side) serial I/O device. Since the $\overline{\text{SRDY}}$ terminal is not utilized in this mode, it can be used as an I/O port.

Figure 4.11.3.1(a) shows the connection example of input/output terminals in the clock synchronous master mode.

Clock synchronous slave mode

In this mode, a synchronous clock from the external (master side) serial input/output device is utilized and 8-bit clock synchronous serial transfers can be performed with this serial interface as the slave.

The synchronous clock is input to the $\overline{\text{SCLK}}$ terminal and is utilized by this interface as the synchronous clock.

Furthermore, the $\overline{\text{SRDY}}$ signal indicating the transmit-receive ready status is output from the $\overline{\text{SRDY}}$ terminal in accordance with the serial interface operating status.

In the slave mode, the settings for registers SCS0 and SCS1 used to select the clock source are invalid. Figure 4.11.3.1(b) shows the connection example of input/output terminals in the clock synchronous slave mode.

7-bit asynchronous mode

In this mode, 7-bit asynchronous transfer can be performed. Parity check during data reception and addition of parity bit (odd/even/none) during transmitting can be specified and data processed in 7 bits with or without parity. Since this mode employs the internal clock, the $\overline{\text{SCLK}}$ terminal is not used. Furthermore, since the $\overline{\text{SRDY}}$ terminal is not utilized either, both of these terminals can be used as I/O ports.

Figure 4.11.3.1(c) shows the connection example of input/output terminals in the asynchronous mode.

8-bit asynchronous 8-bit mode

In this mode, 8-bit asynchronous transfer can be performed. Parity check during data reception and addition of parity bit (odd/even/none) during transmitting can be specified and data processed in 8 bits with or without parity. Since this mode employs the internal clock, the $\overline{\text{SCLK}}$ terminal is not used. Furthermore, since the $\overline{\text{SRDY}}$ terminal is not utilized either, both of these terminals can be used as I/O ports.

Figure 4.11.3.1(c) shows the connection example of input/output terminals in the asynchronous mode.

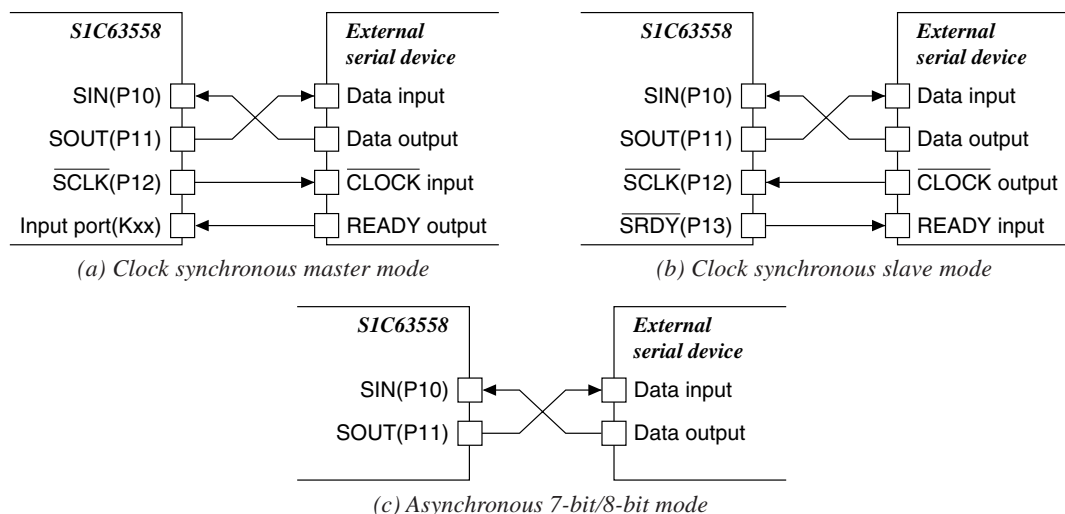

Fig. 4.11.3.1 Connection examples of serial interface I/O terminals

4.11.4 Clock source

There are four clock sources and selection is made by setting the two bits of the clock source selection register SCS0 and SCS1 as shown in table below.

Table 4.11.4.1 Clock source

SCS1	SCS0	Clock source
1	1	Programmable timer
1	0	fosc3 / 93 (2400 bps)
0	1	fosc3 / 372 (600 bps)
0	0	fosc3 / 186 (1200 bps)

This register setting is invalid in clock synchronous slave mode and the external clock input from the SCLK terminal is used.

When the "programmable timer" is selected, the programmable timer 1 underflow signal is divided by 1/2 and this signal used as the clock source. With respect to the transfer rate setting, see "4.10 Programmable Timer". At initial reset, the synchronous clock is set to "fosc3/186".

Whichever clock is selected, the signal is further divided by 1/16 and then used as the synchronous clock. Furthermore, external clock input is used as is for SCLK in clock synchronous slave mode.

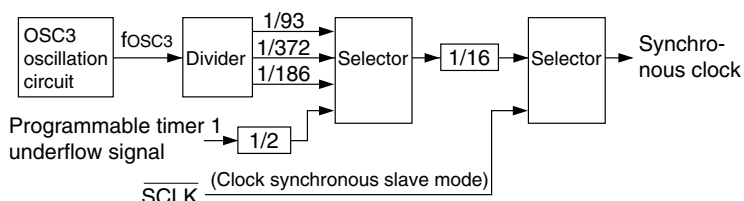

Fig. 4.11.4.1 Division of the synchronous clock

Table 4.11.4.2 shows an examples of transfer rates and OSC3 oscillation frequencies when the clock source is set to programmable timer.

Table 4.11.4.2 OSC3 oscillation frequencies and transfer rates

Transfer rate (bps)	fosc3 = 3.580 MHz	
	PSC1X	RLD1X
9,600	0 (1/1)	0CH
4,800	0 (1/1)	17H
2,400	0 (1/1)	2FH
1,200	0 (1/1)	5DH
600	0 (1/1)	BAH
300	1 (1/4)	5DH
150	1 (1/4)	BAH

When the demultiplied signal of the OSC3 oscillation circuit is made the clock source, it is necessary to turn the OSC3 oscillation ON, prior to using the serial interface.

A time interval of several msec to several 10 msec, from the turning ON of the OSC3 oscillation circuit to until the oscillation stabilizes, is necessary, due to the oscillation element that is used. Consequently, you should allow an adequate waiting time after turning ON of the OSC3 oscillation, before starting transmitting/receiving of serial interface. (The oscillation start time will vary somewhat depending on the oscillator and on the externally attached parts. Refer to the oscillation start time example indicated in Chapter 7, "Electrical Characteristics".)

At initial reset, the OSC3 oscillation circuit is set to OFF status.

4.11.5 Transmit-receive control

Below is a description of the registers which handle transmit-receive control. With respect to transmit-receive control procedures and operations, please refer to the following sections in which these are discussed on a mode by mode basis.

Shift register and receive data buffer

Exclusive shift registers for transmitting and receiving are installed in this serial interface. Consequently, duplex communication simultaneous transmit and receive is possible when the asynchronous system is selected.

Data being transmitted are written to TRXD0–TRXD7 and converted to serial through the shift register and is output from the SOUT terminal.

In the reception section, a receive data buffer is installed separate from the shift register.

Data being received are input to the SIN terminal and is converted to parallel through the shift register and written to the receive data buffer.

Since the receive data buffer can be read even during serial input operation, the continuous data is received efficiently.

However, since buffer functions are not used in clock synchronous mode, be sure to read out data before the next data reception begins.

Transmit enable register and transmit control bit

For transmit control, use the transmit enable register TXEN and transmit control bit TXTRG.

The transmit enable register TXEN is used to set the transmit enable/disable status. When "1" is written to this register to set the transmitting enable status, clock input to the shift register is enabled and the system is ready to transmit data. In the clock synchronous mode, synchronous clock input/output from the $\overline{\text{SCLK}}$ terminal is also enabled.

The transmit control bit TXTRG is used as the trigger to start transmitting data.

Data to be transmitted is written to the transmit data shift register, and when transmitting preparations are complete, "1" is written to TXTRG whereupon data transmitting begins.

When interrupt has been enabled, an interrupt is generated when the transmission is completed. If there is subsequent data to be transmitted it can be sent using this interrupt.

In addition, TXTRG can be read as a status bit. When set to "1", it indicates transmitting operation, and "0" indicates transmitting stop.

For details on timing, see the timing chart which gives the timing for each mode.

When not transmitting, set TXEN to "0" to disable transmission.

Receive enable register, receive control bit

For receiving control, use the receive enable register RXEN and receive control bit RXTRG.

Receive enable register RXEN is used to set receiving enable/disable status. When "1" is written into this register to set the receiving enable status, clock input to the shift register is enabled and the system is ready to receive data. In the clock synchronous mode, synchronous clock input/output from the $\overline{\text{SCLK}}$ terminal is also enabled.

With the above setting, receiving begins and serial data input from the SIN terminal goes to the shift register.

The operation of the receive control bit RXTRG is slightly different depending on whether a clock synchronous system or an asynchronous system is being used.

In the clock synchronous system, the receive control bit TXTRG is used as the trigger to start receiving data.

When received data has been read and the preparation for next data receiving is completed, write "1" into RXTRG to start receiving. (When "1" is written to RXTRG in slave mode, SRDY switches to "0".)

In an asynchronous system, RXTRG is used to prepare for next data receiving. After reading the received data from the receive data buffer, write "1" into RXTRG to signify that the receive data buffer is empty. If "1" is not written into RXTRG, the overrun error flag OER will be set to "1" when the next receiving operation is completed. (An overrun error will be generated when receiving is completed between reading the received data and the writing of "1" to RXTRG.)

In addition, RXTRG can be read as a status bit. In either clock synchronous mode or asynchronous mode, when RXTRG is set to "1", it indicates receiving operation and when set to "0", it indicates that receiving has stopped.

For details on timing, see the timing chart which gives the timing for each mode.

When you do not receive, set RXEN to "0" to disable receiving.

4.11.6 Operation of clock synchronous transfer

Clock synchronous transfer involves the transfer of 8-bit data by synchronizing it to eight clocks. The same synchronous clock is used by both the transmitting and receiving sides.

When the serial interface is used in the master mode, the clock signal selected using SCS0 and SCS1 is further divided by 1/16 and employed as the synchronous clock. This signal is then sent via the $\overline{\text{SCLK}}$ terminal to the slave side (external serial I/O device).

When used in the slave mode, the clock input to the $\overline{\text{SCLK}}$ terminal from the master side (external serial input/output device) is used as the synchronous clock.

In the clock synchronous mode, since one clock line ($\overline{\text{SCLK}}$) is shared for both transmitting and receiving, transmitting and receiving cannot be performed simultaneously. (Half duplex only is possible in clock synchronous mode.)

Transfer data is fixed at 8 bits and both transmitting and receiving are conducted with the LSB (bit 0) coming first.

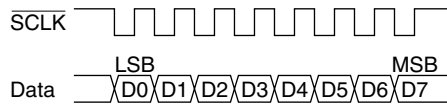

Fig. 4.11.6.1 Transfer data configuration using clock synchronous mode

Below is a description of initialization when performing clock synchronous transfer, transmit-receive control procedures and operations.

With respect to serial interface interrupt, see "4.11.8 Interrupt function".

Initialization of serial interface

When performing clock synchronous transfer, the following initial settings must be made.

(1) Setting of transmitting/receiving disable

To set the serial interface into a status in which both transmitting and receiving are disabled, "0" must be written to both the transmit enable register TXEN and the receive enable register RXEN. Fix these two registers to a disable status until data transfer actually begins.

(2) Port selection

Because serial interface input/output ports SIN, SOUT, $\overline{\text{SCLK}}$ and $\overline{\text{SRDY}}$ are set as I/O port terminals P10–P13 at initial reset, "1" must be written to the serial interface enable register ESIF in order to set these terminals for serial interface use.

(3) Setting of transfer mode

Select the clock synchronous mode by writing the data as indicated below to the two bits of the mode selection registers SMD0 and SMD1.

Master mode: SMD0 = "0", SMD1 = "0"

Slave mode: SMD0 = "1", SMD1 = "0"

(4) Clock source selection

In the master mode, select the synchronous clock source by writing data to the two bits of the clock source selection registers SCS0 and SCS1. (See Table 4.11.4.1.)

This selection is not necessary in the slave mode.

The parity enable register EPR is also assigned to this address, however, since parity is not necessary in the clock synchronous mode, parity check will not take place regardless of how they are set.

(5) Clock source control

When the master mode is selected and programmable timer for the clock source is selected, set transfer rate on the programmable timer side. (See "4.10 Programmable Timer".)

When the divided signal of OSC3 oscillation circuit is selected for the clock source, be sure that the OSC3 oscillation circuit is turned ON prior to commencing data transfer. (See "4.3 Oscillation Circuit".)

Note that the frequency of the serial interface clock is limited to a maximum of 1 MHz.

Data transmit procedure

The control procedure and operation during transmitting is as follows.

- (1) Write "0" in the transmit enable register TXEN and the receive enable register RXEN to reset the serial interface.
- (2) Write "1" in the transmit enable register TXEN to set into the transmitting enable status.
- (3) Write the transmitting data into TRXD0–TRXD7.
- (4) In case of the master mode, confirm the receive ready status on the slave side (external serial input/output device), if necessary. Wait until it reaches the receive ready status.
- (5) Write "1" in the transmit control bit TXTRG and start transmitting.

In the master mode, this control causes the synchronous clock to change to enable and to be provided to the shift register for transmitting and output from the \overline{SCLK} terminal.

In the slave mode, it waits for the synchronous clock to be input from the \overline{SCLK} terminal.

The transmitting data of the shift register shifts one bit at a time at each falling edge of the synchronous clock and is output from the SOUT terminal. When the final bit (MSB) is output, the SOUT terminal is maintained at that level, until the next transmitting begins.

The transmitting complete interrupt factor flag ISTR is set to "1" at the point where the data transmitting of the shift register is completed. When interrupt has been enabled, a transmitting complete interrupt is generated at this point. Set the following transmitting data using this interrupt.

- (6) Repeat steps (3) to (5) for the number of bytes of transmitting data, and then set the transmit disable status by writing "0" to the transmit enable register TXEN, when the transmitting is completed.

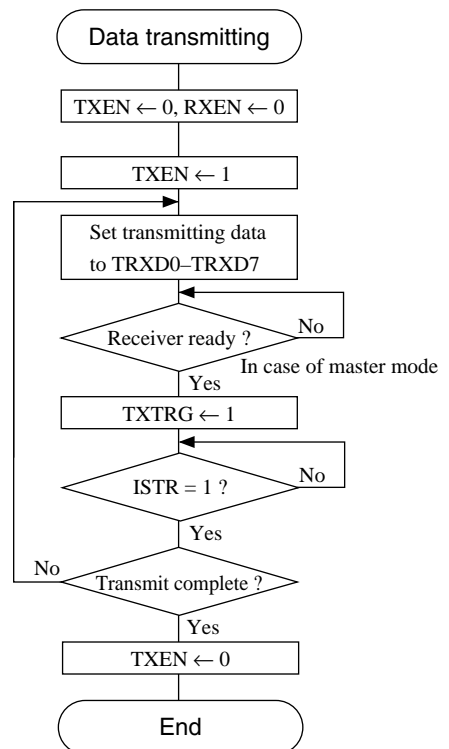

Fig. 4.11.6.2 Transmit procedure in clock synchronous mode

Data receive procedure

The control procedure and operation during receiving is as follows.

- (1) Write "0" in the receive enable register RXEN and transmit enable register TXEN to reset the serial interface.
- (2) Write "1" in the receive enable register RXEN to set into the receiving enable status.
- (3) In case of the master mode, confirm the transmit ready status on the slave side (external serial input/output device), if necessary. Wait until it reaches the transmit ready status.
- (4) Write "1" in the receive control bit RXTRG and start receiving.

In the master mode, this control causes the synchronous clock to change to enable and is provided to the shift register for receiving and output from the \overline{SCLK} terminal.

In the slave mode, it waits for the synchronous clock to be input from the \overline{SCLK} terminal. The received data input from the SIN terminal is successively incorporated into the shift register in synchronization with the rising edge of the synchronous clock.

At the point where the data of the 8th bit has been incorporated at the final (8th) rising edge of the synchronous clock, the content of the shift register is sent to the receive data buffer and the receiving complete interrupt factor flag ISRC is set to "1". When interrupt has been enabled, a receiving complete interrupt is generated at this point.

- (5) Read the received data from TRXD0–TRXD7 using receiving complete interrupt.
- (6) Repeat steps (3) to (5) for the number of bytes of receiving data, and then set the receive disable status by writing "0" to the receive enable register RXEN, when the receiving is completed.

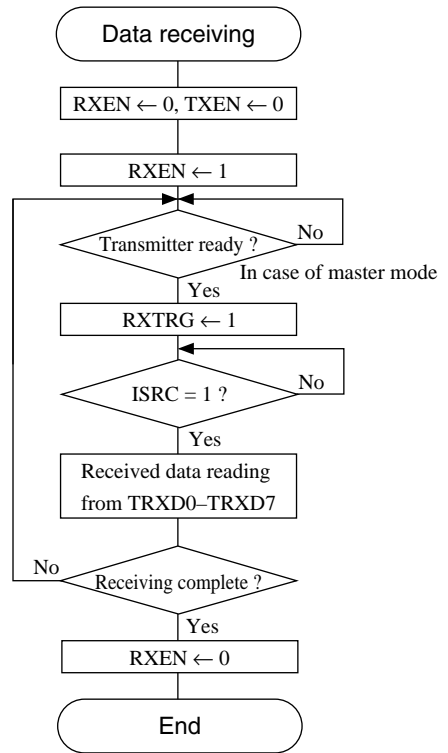

Fig. 4.11.6.3 Receiving procedure in clock synchronous mode

Transmit/receive ready (SRDY) signal

When this serial interface is used in the clock synchronous slave mode (external clock input), an $\overline{\text{SRDY}}$ signal is output to indicate whether or not this serial interface can transmit/receive to the master side (external serial input/output device). This signal is output from the SRDY terminal and when this interface enters the transmit or receive enable (READY) status, it becomes "0" (Low level) and becomes "1" (High level) when there is a BUSY status, such as during transmit/receive operation. The $\overline{\text{SRDY}}$ signal changes the "1" to "0," immediately after writing "1" into the transmit control bit TXTRG or the receive control bit RXTRG and returns from "0" to "1", at the point where the first synchronous clock has been input (falling edge).

When you have set in the master mode, control the transfer by inputting the same signal from the slave side using the input port or I/O port. At this time, since the $\overline{\text{SRDY}}$ terminal is not set and instead P13 functions as the I/O port, you can apply this port for said control.

Timing chart

The timing chart for the clock synchronous system transmission is shown in Figure 4.11.6.4.

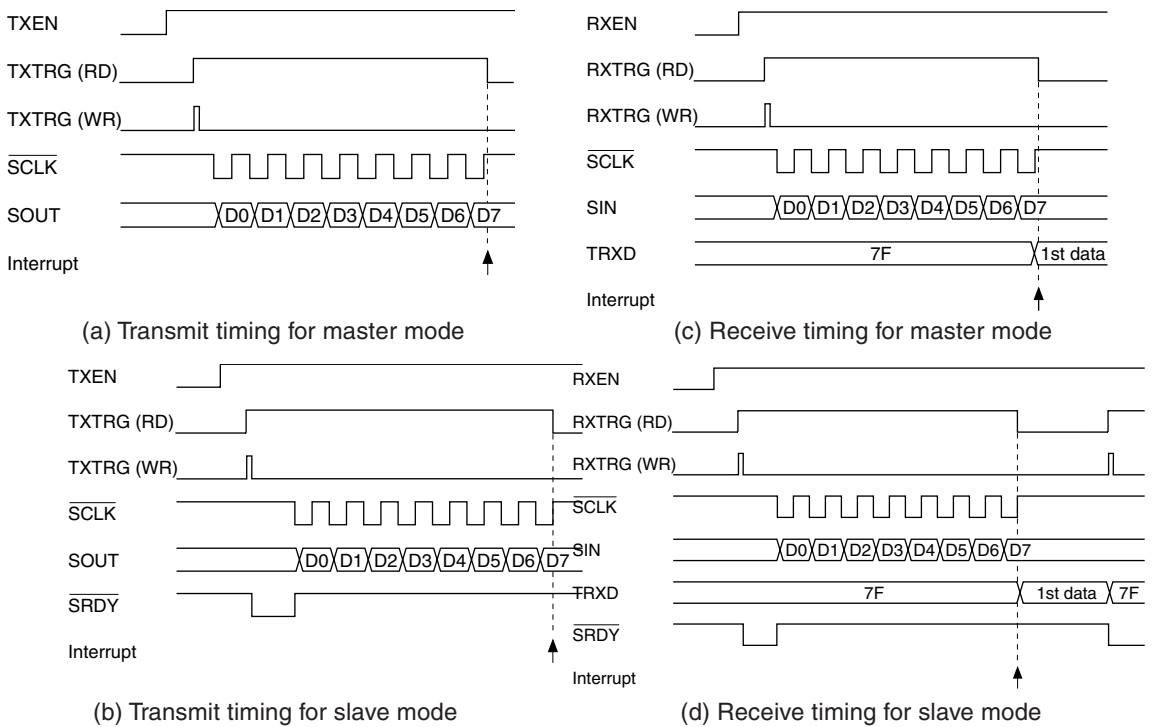

Fig. 4.11.6.4 Timing chart (clock synchronous system transmission)

4.11.7 Operation of asynchronous transfer

Asynchronous transfer is a mode that transfers by adding a start bit and a stop bit to the front and the back of each piece of serial converted data. In this mode, there is no need to use a clock that is fully synchronized clock on the transmit side and the receive side, but rather transmission is done while adopting the synchronization at the start/stop bits that have attached before and after each piece of data. The RS-232C interface functions can be easily realized by selecting this transfer mode.

This interface has separate transmit and receive shift registers and is designed to permit full duplex transmission to be done simultaneously for transmitting and receiving.

For transfer data in the 7-bit asynchronous mode, either 7 bits data (no parity) or 7 bits data + parity bit can be selected. In the 8-bit asynchronous mode, either 8 bits data (no parity) or 8 bits data + parity bit can be selected.

Parity can be even or odd, and parity checking of received data and adding a party bit to transmitting data will be done automatically. Thereafter, it is not necessary to be conscious of parity itself in the program.

The start bit and stop bit are respectively fixed at one bit and data is transmitted and received by placing the LSB (bit 0) at the front.

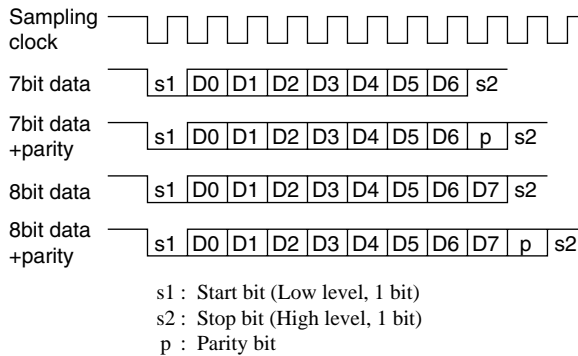

Fig. 4.11.7.1 Transfer data configuration for asynchronous system

Here following, we will explain the control sequence and operation for initialization and transmitting / receiving in case of asynchronous data transfer. See "4.11.8 Interrupt function" for the serial interface interrupts.

Initialization of serial interface

The below initialization must be done in cases of asynchronous system transfer.

(1) Setting of transmitting/receiving disable

To set the serial interface into a status in which both transmitting and receiving are disabled, "0" must be written to both the transmit enable register TXEN and the receive enable register RXEN. Fix these two registers to a disable status until data transfer actually begins.

(2) Port selection

Because serial interface input/output terminals SIN and SOUT are set as I/O port terminals P10 and P11 at initial reset, "1" must be written to the serial interface enable register ESIF in order to set these terminals for serial interface use.

SCLK and SRDY terminals set in the clock synchronous mode are not used in the asynchronous mode. These terminals function as I/O port terminals P12 and P13.

(3) Setting of transfer mode

Select the asynchronous mode by writing the data as indicated below to the two bits of the mode selection registers SMD0 and SMD1.

7-bit mode: SMD0 = "0", SMD1 = "1"

8-bit mode: SMD0 = "1", SMD1 = "1"

(4) Parity bit selection

When checking and adding parity bits, write "1" into the parity enable register EPR to set to "with parity check". As a result of this setting, in the 7-bit asynchronous mode, it has a 7 bits data + parity bit configuration and in the 8-bit asynchronous mode it has an 8 bits data + parity bit configuration. In this case, parity checking for receiving and adding a parity bit for transmitting is done automatically in hardware. Moreover, when "with parity check" has been selected, "odd" or "even" parity must be further selected in the parity mode selection register PMD.

When "0" is written to the PMD register to select "without parity check" in the 7-bit asynchronous mode, data configuration is set to 7 bits data (no parity) and in the 8-bit asynchronous mode (no parity) it is set to 8 bits data (no parity) and parity checking and parity bit adding will not be done.

(5) Clock source selection

Select the clock source by writing data to the two bits of the clock source selection registers SCS0 and SCS1. (See Table 4.11.4.1.)

(6) Clock source control

When the programmable timer is selected for the clock source, set transfer rate on the programmable timer side. (See "4.10 Programmable Timer".)

When the divided signal of OSC3 oscillation circuit is selected for the clock source, be sure that the OSC3 oscillation circuit is turned ON prior to commencing data transfer. (See "4.3 Oscillation Circuit".)

Data transmit procedure

The control procedure and operation during transmitting is as follows.

- (1) Write "0" in the transmit enable register TXEN to reset the serial interface.
- (2) Write "1" in the transmit enable register TXEN to set into the transmitting enable status.
- (3) Write the transmitting data into TRXD0–TRXD7.
Also, when 7-bit data is selected, the TRXD7 data becomes invalid.

- (4) Write "1" in the transmit control bit TXTRG and start transmitting.

This control causes the shift clock to change to enable and a start bit (LOW) is output to the SOUT terminal in synchronize to its rising edge. The transmitting data set to the shift register is shifted one bit at a time at each rising edge of the clock thereafter and is output from the SOUT terminal. After the data output, it outputs a stop bit (HIGH) and HIGH level is maintained until the next start bit is output.

The transmitting complete interrupt factor flag ISTR is set to "1" at the point where the data transmitting is completed. When interrupt has been enabled, a transmitting complete interrupt is generated at this point.

Set the following transmitting data using this interrupt.

- (5) Repeat steps (3) to (4) for the number of bytes of transmitting data, and then set the transmit disable status by writing "0" to the transmit enable register TXEN, when the transmitting is completed.

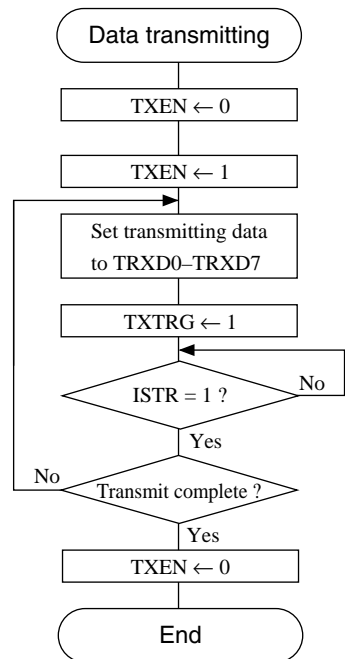

Fig. 4.11.7.2 Transmit procedure in asynchronous mode

Data receive procedure

The control procedure and operation during receiving is as follows.

- (1) Write "0" in the receive enable register RXEN to set the receiving disable status and to reset the respective PER, OER, FER flags that indicate parity, overrun and framing errors.
- (2) Write "1" in the receive enable register RXEN to set into the receiving enable status.
- (3) The shift clock will change to enable from the point where the start bit (LOW) has been input from the SIN terminal and the receive data will be synchronized to the rising edge following the second clock, and will thus be successively incorporated into the shift register.

After data bits have been incorporated, the stop bit is checked and, if it is not HIGH, it becomes a framing error and the error interrupt factor flag ISER is set to "1". When interrupt has been enabled, an error interrupt is generated at this point. When receiving is completed, data in the shift register is transferred to the receive data buffer and the receiving complete interrupt flag ISRC is set to "1". When interrupt has been enabled, a receiving complete interrupt is generated at this point. (When an overrun error is generated, the interrupt factor flag ISRC is not set to "1" and a receiving complete interrupt is not generated.)

If "with parity check" has been selected, a parity check is executed when data is transferred into the receive data buffer from the shift register and if a parity error is detected, the error interrupt factor flag is set to "1". When the interrupt has been enabled, an error interrupt is generated at this point just as in the framing error mentioned above.

- (4) Read the received data from TRXD0–TRXD7 using receiving complete interrupt.
- (5) Write "1" to the receive control bit RXTRG to inform that the receive data has been read out. When the following data is received prior to writing "1" to RXTRG, it is recognized as an overrun error and the error interrupt factor flag is set to "1". When the interrupt has been enabled, an error interrupt is generated at this point just as in the framing error and parity error mentioned above.
- (6) Repeat steps (3) to (5) for the number of bytes of receiving data, and then set the receive disable status by writing "0" to the receive enable register RXEN, when the receiving is completed.

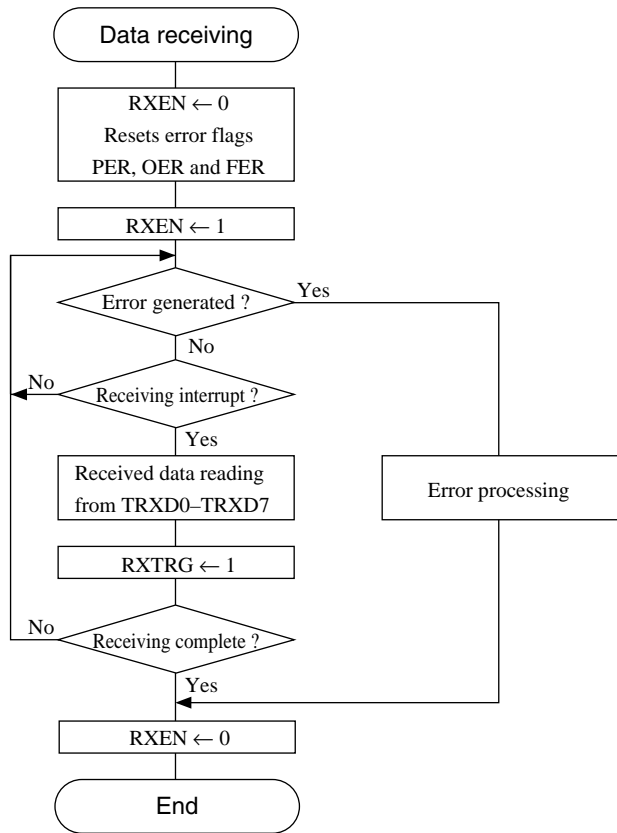

Fig. 4.11.7.3 Receiving procedure in asynchronous mode

Receive error

During receiving the following three types of errors can be detected by an interrupt.

(1) Parity error

When writing "1" to the EPR register to select "with parity check", a parity check (vertical parity check) is executed during receiving. After each data bit is sent a parity check bit is sent. The parity check bit is a "0" or a "1". Even parity checking will cause the sum of the parity bit and the other bits to be even. Odd parity causes the sum to be odd. This is checked on the receiving side.

The parity check is performed when data received in the shift register is transferred to the receive data buffer. It checks whether the parity check bit is a "1" or a "0" (the sum of the bits including the parity bit) and the parity set in the PMD register match. When it does not match, it is recognized as an parity error and the parity error flag PER and the error interrupt factor flag ISER is set to "1". When interrupt has been enabled, an error interrupt is generated at this point.

The PER flag is reset to "0" by writing "1".

Even when this error has been generated, the received data corresponding to the error is transferred in the receive data buffer and the receive operation also continues.

The received data at this point cannot assured because of the parity error.

(2) Framing error

In asynchronous transfer, synchronization is adopted for each character at the start bit ("0") and the stop bit ("1"). When receiving has been done with the stop bit set at "0", the serial interface judges the synchronization to be off and a framing error is generated. When this error is generated, the framing error flag FER and the error interrupt factor flag ISER are set to "1". When interrupt has been enabled, an error interrupt is generated at this point.

The FER flag is reset to "0" by writing "1".

Even when this error has been generated, the received data for it is loaded into the receive data buffer and the receive operation also continues. However, even when it does not become a framing error with the following data receipt, such data cannot be assured.

Even when this error has been generated, the received data corresponding to the error is transferred in the receive data buffer and the receive operation also continues. However, even when it does not become a framing error with the following data receiving, such data cannot be assured.

(3) Overrun error

When the next data is received before "1" is written to RXTRG, an overrun error will be generated, because the previous receive data will be overwritten. When this error is generated, the overrun error flag OER and the error interrupt factor flag ISER are set to "1". When interrupt has been enabled, an error interrupt is generated at this point. The OER flag is reset to "0" by writing "1" into it.

Even when this error has been generated, the received data corresponding to the error is transferred in the receive data buffer and the receive operation also continues.

Furthermore, when the timing for writing "1" to RXTRG and the timing for the received data transfer to the receive data buffer overlap, it will be recognized as an overrun error.

Timing chart

Figure 4.11.7.4 show the asynchronous transfer timing chart.

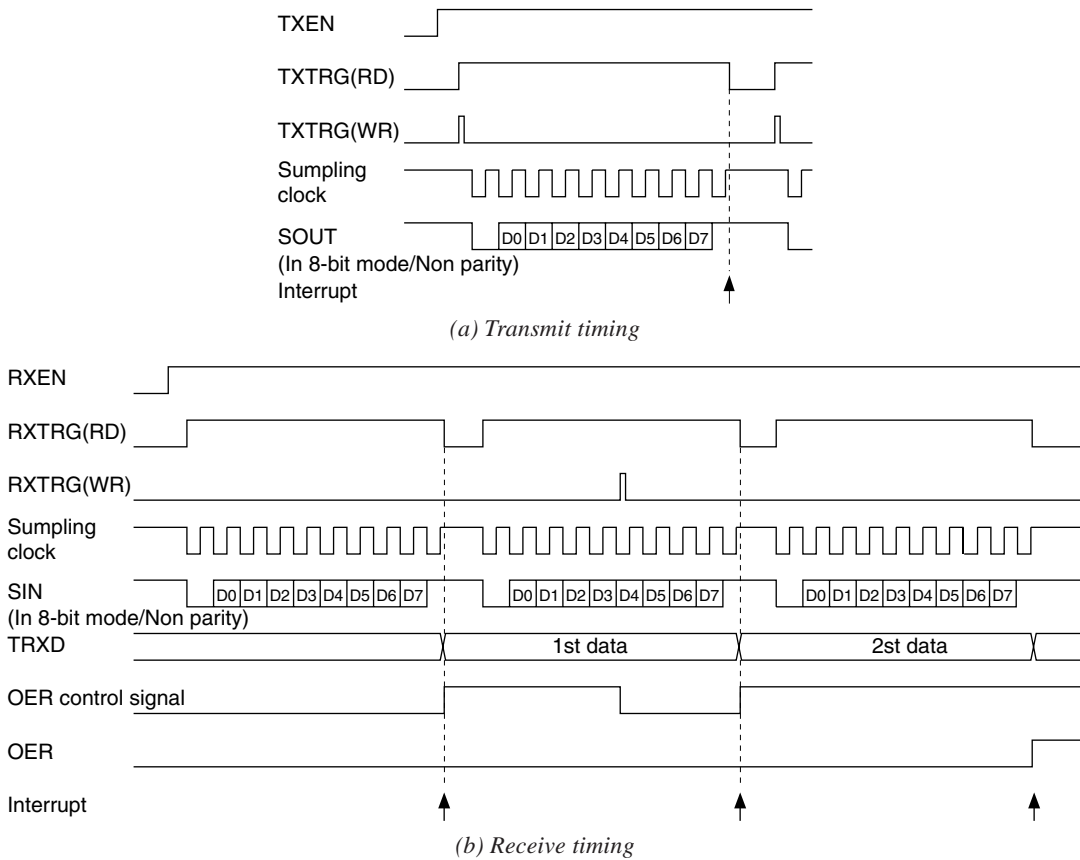

Fig. 4.11.7.4 Timing chart (asynchronous transfer)

4.11.8 Interrupt function

This serial interface includes a function that generates the below indicated three types of interrupts.

- Transmitting complete interrupt
- Receiving complete interrupt
- Error interrupt

The interrupt factor flag ISxx and the interrupt mask register EISxx for the respective interrupt factors are provided and then the interrupt can be disabled/enabled by the software.

Figure 4.11.8.1 shows the configuration of the serial interface interrupt circuit.

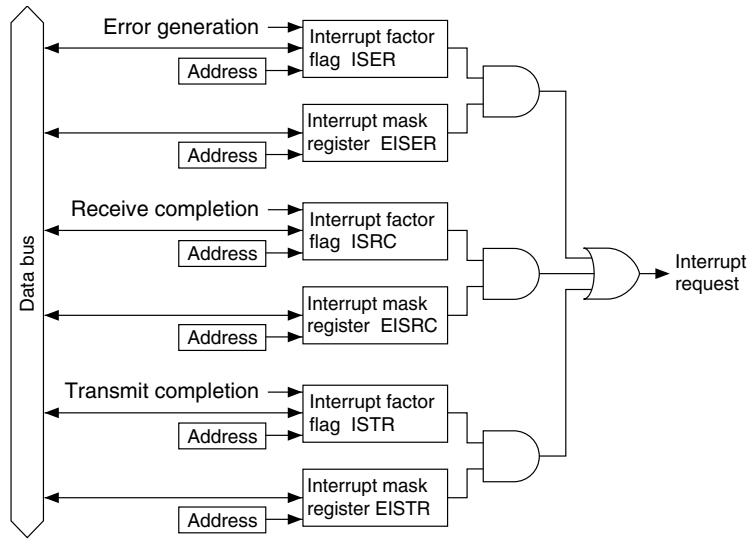

Fig. 4.11.8.1 Configuration of serial interface interrupt circuit

Transmit completion interrupt

This interrupt factor is generated at the point where the sending of the data written into the shift register has been completed and sets the interrupt factor flag ISTR to "1". When set in this manner, if the corresponding interrupt mask register EISTR is set to "1" and the CPU is set to interrupt enabled status (I flag = "1"), an interrupt will be generated to the CPU.

When the interrupt mask register EISTR has been set to "0" and interrupt has been disabled, no interrupt is generated to the CPU. Even in this case, the interrupt factor flag ISTR is set to "1".

The interrupt factor flag ISTR is reset to "0" by writing "1".

The following transmitting data can be set and the transmitting can be started (writing "1" to TXTRG) after this interrupt factor occurs.

Receive completion interrupt

This interrupt factor is generated at the point where receiving has been completed and the receive data incorporated into the shift register has been transferred into the receive data buffer and it sets the interrupt factor flag ISRC to "1". When set in this manner, if the corresponding interrupt mask register EISRC is set to "1" and the CPU is set to interrupt enabled status (I flag = "1"), an interrupt will be generated to the CPU.

When the interrupt mask register EISRC has been set to "0" and interrupt has been disabled, no interrupt is generated to the CPU. Even in this case, the interrupt factor flag ISRC is set to "1".

The interrupt factor flag ISRC is reset to "0" by writing "1".

The generation of this interrupt factor allows reading of the received data.

Also, the interrupt factor flag ISRC is set to "1" when a parity error or framing error is generated.

Error interrupt

This interrupt factor is generated at the point where a parity error, framing error or overrun error is detected during receiving and it sets the interrupt factor flag ISER to "1". When set in this manner, if the corresponding interrupt mask register EISER is set to "1" and the CPU is set to interrupt enabled status (I flag = "1"), an interrupt will be generated to the CPU.

When the interrupt mask register EISER has been set to "0" and interrupt has been disabled, an interrupt is not generated to the CPU. Even in this case, the interrupt factor flag ISER is set to "1".

The interrupt factor flag ISER is reset to "0" by writing "1".

Since all three types of errors result in the same interrupt factor, you should identify the error that has been generated by the error flags PER (parity error), OER (overrun error) and FER (framing error).

4.11.9 I/O memory of serial interface

Tables 4.11.9.1(a) and (b) show the serial interface control bits and their addresses.

Table 4.11.9.1(a) Serial interface control bits

Address	Register				Name	Init *1	1	0	Comment
	D3	D2	D1	D0					
FF45H	PUL13	PUL12	PUL11	PUL10	PUL13	1	On	Off	P13 pull-up control register
					PUL12	1	On	Off	General-purpose register when SIF (clock sync. slave) is selected P12 pull-up control register
	R/W				PUL11	1	On	Off	General-purpose register when SIF (clock sync. master) is selected SCLK (1) pull-up control register when SIF (clock sync. slave) is selected
	R/W				PUL10	1	On	Off	P11 pull-up control register (ESIF=0) General-purpose register when SIF is selected P10 pull-up control register (ESIF=0) SIN pull-up control register when SIF is selected
FF4DH	PUL33	PUL32	PUL31	PUL30	PUL33	1	On	Off	P33 pull-up control register
					PUL32	1	On	Off	General-purpose register when SIF (clock sync. slave) is selected P32 pull-up control register
	R/W				PUL31	1	On	Off	General-purpose register when SIF (clock sync. master) is selected SCLK (1) pull-up control register when SIF (clock sync. slave) is selected
	R/W				PUL30	1	On	Off	P31 pull-up control register (ESIFS=0) General-purpose register when SIF is selected P30 pull-up control register (ESIFS=0) SIN pull-up control register when SIF is selected
FF58H	0	SMD1S	SMD0S	ESIFS	0 *3	-*2			Unused
	R	R/W			SMD1S	0			Serial I/F (2) Mode
FF59H	EPRS	PMDS	SCS1S	SCS0S	EPRS	0	Enable	Disable	Serial I/F (2) parity enable register
					PMDS	0	Odd	Even	Serial I/F (2) parity mode selection
	R/W				SCS1S	0			SIF (2) clock
	R/W				SCS0S	0			source selection Mode
FF5AH	RXTRGS	RXENS	TXTRGS	TXENS	RXTRGS	0	Run	Stop	Serial I/F (2) receive status (reading)
					RXENS	0	Enable	Disable	Serial I/F (2) receive trigger (writing)
	R/W				TXTRGS	0	Run	Stop	Serial I/F (2) receive enable
	R/W				TXENS	0	Trigger	Enable	Disable
FF5BH	0	FERS	PERS	OERS	FERS	0	Error	No error	Serial I/F (2) framing error flag status (reading)
					PERS	0	Error	No error	Serial I/F (2) framing error flag reset (writing)
	R	R/W			OERS	0	Reset	No error	Serial I/F (2) parity error flag status (reading)
		R/W			OERS	0	Reset	No error	Serial I/F (2) parity error flag reset (writing)
FF5CH	TRXD3S	TRXD2S	TRXD1S	TRXD0S	TRXD3S	-*2	High	Low	Serial I/F (2) transmit/receive data (low-order 4 bits)
					TRXD2S	-*2	High	Low	
	R/W				TRXD1S	-*2	High	Low	
	R/W				TRXD0S	-*2	High	Low	
FF5DH	TRXD7S	TRXD6S	TRXD5S	TRXD4S	TRXD7S	-*2	High	Low	MSB
					TRXD6S	-*2	High	Low	
	R/W				TRXD5S	-*2	High	Low	
	R/W				TRXD4S	-*2	High	Low	

*1 Initial value at initial reset

*2 Not set in the circuit

*3 Constantly "0" when being read

Table 4.11.9.1(b) Serial interface control bits

Address	Register				Comment				
	D3	D2	D1	D0	Name	Init *1	1	0	
FF70H	0	SMD1	SMD0	ESIF	0 *3	- *2			Unused
	R	R/W			SMD1	0			Serial I/F (1) Mode
					SMD0	0			mode selection
					ESIF	0	SIF	I/O	Serial I/F (1) enable (P1x port function selection)
FF71H	EPR	PMD	SCS1	SCS0	EPR	0	Enable	Disable	Serial I/F (1) parity enable register
	R/W				PMD	0	Odd	Even	Serial I/F (1) parity mode selection
					SCS1	0			SIF (1) clock
					SCS0	0			source selection
FF72H	RXTRG	RXEN	TXTRG	TXEN	RXTRG	0	Run	Stop	Serial I/F (1) receive status (reading)
	R/W				RXEN	0	Enable	Disable	Serial I/F (1) receive enable
					TXTRG	0	Run	Stop	Serial I/F (1) transmit status (reading)
					TXEN	0	Trigger	-	Serial I/F (1) transmit trigger (writing)
					TXEN	0	Enable	Disable	Serial I/F (1) transmit enable
FF73H	0	FER	PER	OER	0 *3	- *2			Unused
	R	R/W			FER	0	Error	No error	Serial I/F (1) framing error flag status (reading)
					PER	0	Error	No error	Serial I/F (1) parity error flag status (reading)
					OER	0	Error	No error	Serial I/F (1) overrun error flag status (reading)
FF74H	TRXD3	TRXD2	TRXD1	TRXD0	TRXD3	- *2	High	Low	Serial I/F (1) transmit/receive data (low-order 4 bits)
	R/W				TRXD2	- *2	High	Low	
					TRXD1	- *2	High	Low	
					TRXD0	- *2	High	Low	
	FF75H	TRXD7	TRXD6	TRXD5	TRXD4	TRXD7	- *2	High	Low
R/W				TRXD6	- *2	High	Low		
				TRXD5	- *2	High	Low		
				TRXD4	- *2	High	Low		
FFE3H		0	EISER	EISTR	EISRC	0 *3	- *2		
	R	R/W			EISER	0	Enable	Mask	Interrupt mask register (Serial I/F (1) error)
					EISTR	0	Enable	Mask	Interrupt mask register (Serial I/F (1) transmit completion)
					EISRC	0	Enable	Mask	Interrupt mask register (Serial I/F (1) receive completion)
FFE8H	0	EISERS	EISTRS	EISRCS	0 *3	- *2			Unused
	R	R/W			EISERS	0	Enable	Mask	Interrupt mask register (Serial I/F (2) error)
					EISTRS	0	Enable	Mask	Interrupt mask register (Serial I/F (2) transmit completion)
					EISRCS	0	Enable	Mask	Interrupt mask register (Serial I/F (2) receive completion)
FFF3H	0	ISER	ISTR	ISRC	0 *3	- *2	(R)	(R)	Unused
	R	R/W			ISER	0	Yes	No	Interrupt factor flag (Serial I/F (1) error)
					ISTR	0	(W)	(W)	Interrupt factor flag (Serial I/F (1) transmit completion)
					ISRC	0	Reset	Invalid	Interrupt factor flag (Serial I/F (1) receive completion)
FFF8H	0	ISERS	ISTRS	ISRCS	0 *3	- *2	(R)	(R)	Unused
	R	R/W			ISERS	0	Yes	No	Interrupt factor flag (Serial I/F (2) error)
					ISTRS	0	(W)	(W)	Interrupt factor flag (Serial I/F (2) transmit completion)
					ISRCS	0	Reset	Invalid	Interrupt factor flag (Serial I/F (2) receive completion)

*1 Initial value at initial reset

*2 Not set in the circuit

*3 Constantly "0" when being read

ESIF: Serial interface (1) enable register (P1 port function selection) (FF70H•D0)

ESIFS: Serial interface (2) enable register (P3 port function selection) (FF58H•D0)

Sets P10–P13 to the input/output port for the serial interface.

When "1" is written: Serial interface

When "0" is written: I/O port

Reading: Valid

The ESIF is the serial interface (1), the ESIFS is the serial interface (2) enable registers and P10–P13, P30–P33 terminals become serial input/output terminals (SIN, SOUT, SCLK, SRDY) when "1" is written, and they become I/O port terminals when "0" is written.

Also, see Table 4.11.3.2 for the terminal settings according to the transfer modes.

At initial reset, this register is set to "0".

Note: After setting ESIF to "1", wait at least 10 μsec before starting actual data transfer since a hazard may be generated from the P12 (SCLK) terminal when ESIF is set to "1".

Also, setting ESIFS to "1" may cause a hazard to be generated from the P32 (SCLK) terminal, so a 10 μsec or more interval is also needed here.

PUL10: Serial interface (1) SIN pull-up control register (FF45H•D0)

PUL12: Serial interface (1) SCLK pull-up control register (FF45H•D2)

PUL30: Serial interface (2) SIN pull-up control register (FF4DH•D0)

PUL32: Serial interface (2) SCLK pull-up control register (FF4DH•D2)

Sets the pull-up of the SIN terminal and the SCLK terminals (in the slave mode).

When "1" is written: Pull-up ON

When "0" is written: Pull-up OFF

Reading: Valid

Sets the pull-up resistor built into the SIN (P10/P30) and SCLK (P12/P32) terminals to ON or OFF. (Pull-up resistor is only built in the port selected by mask option.)

SCLK pull-up is effective only in the slave mode. In the master mode, the PUL12/PUL32 register can be used as a general purpose register.

At initial reset, these registers are set to "1" and the lines are pulled up.

SMD0, SMD1: Serial interface (1) mode selection register (FF70H•D1, D2)

SMD0S, SMD1S: Serial interface (2) mode selection register (FF58H•D1, D2)

Set the transfer modes as shown in Table 4.11.9.2.

Table 4.11.9.2 Transfer mode settings

SMD1/SMD1S	SMD0/SMD0S	Mode
1	1	8-bit asynchronous
1	0	7-bit asynchronous
0	1	Clock synchronous slave
0	0	Clock synchronous master

This register can also read out.

At initial reset, this register is set to "0".

SCS0, SCS1: Serial interface (1) clock source selection register (FF71H•D0, D1)

SCS0S, SCS1S: Serial interface (2) clock source selection register (FF59H•D0, D1)

Select the clock source as shown in Table 4.11.9.3.

Table 4.11.9.3 Clock source selection

SCS1	SCS0	Clock source
1	1	Programmable timer
1	0	fosc3 / 93 (2400 bps)
0	1	fosc3 / 372 (600 bps)
0	0	fosc3 / 186 (1200 bps)

This register can also be read out.

In the clock synchronous slave mode, setting of this register is invalid.

At initial reset, this register is set to "0".

EPR: Serial interface (1) parity enable register (FF71H•D3)**EPRS: Serial interface (2) parity enable register (FF59H•D3)**

Selects the parity function.

When "1" is written: With parity
 When "0" is written: Non parity
 Reading: Valid

Selects whether or not to check parity of the received data and to add a parity bit to the transmitting data. When "1" is written to EPR/EPRS, the most significant bit of the received data is considered to be the parity bit and a parity check is executed. A parity bit is added to the transmitting data. When "0" is written, neither checking is done nor is a parity bit added.

Parity is valid only in asynchronous mode and the EPR/EPRS setting becomes invalid in the clock synchronous mode.

At initial reset, this register is set to "0".

PMD: Serial interface (1) parity mode selection register (FF71H•D2)**PMDS: Serial interface (2) parity mode selection register (FF59H•D2)**

Selects odd parity/even parity.

When "1" is written: Odd parity
 When "0" is written: Even parity
 Reading: Valid

When "1" is written to PMD/PMDS, odd parity is selected and even parity is selected when "0" is written. The parity check and addition of a parity bit is only valid when "1" has been written to EPR/EPRS. When "0" has been written to EPR/EPRS, the parity setting by PMD/PMDS becomes invalid.

At initial reset, this register is set to "0".

TXEN: Serial interface (1) transmit enable register (FF72H•D0)**TXENS: Serial interface (2) transmit enable register (FF5AH•D0)**

Sets the serial interface to the transmit enabled status.

When "1" is written: Transmit enabled
 When "0" is written: Transmit disabled
 Reading: Valid

When "1" is written to TXEN/TXENS, the serial interface shifts to the transmit enabled status and shifts to the transmit disabled status when "0" is written.

Set TXEN/TXENS to "0" when making the initial settings of the serial interface and similar operations.

At initial reset, this register is set to "0".

TXTRG: Serial interface (1) transmit trigger/status (FF72H•D1)**TXTRGS: Serial interface (2) transmit trigger/status (FF5AH•D1)**

Functions as the transmit start trigger and the operation status indicator (transmitting/stop status).

When "1" is read: During transmitting
 When "0" is read: During stop
 When "1" is written: Start transmitting
 When "0" is written: Invalid

Starts transmitting when "1" is written to TXTRG/TXTRGS after writing the transmitting data.

TXTRG/TXTRGS can be read as the status. When set to "1", it indicates transmitting operation, and "0" indicates transmitting stop.

At initial reset, TXTRG/TXTRGS is set to "0".

RXEN: Serial interface (1) receive enable register (FF72H•D2)

RXENS: Serial interface (2) receive enable register (FF5AH•D2)

Sets the serial interface to the receive enabled status.

When "1" is written: Receive enabled

When "0" is written: Receive disabled

Reading: Valid

When "1" is written to RXEN/RXENS, the serial interface shifts to the receive enabled status and shifts to the receive disabled status when "0" is written.

Set RXEN/RXENS to "0" when making the initial settings of the serial interface and similar operations.

At initial reset, this register is set to "0".

RXTRG: Serial interface (1) receive trigger/status (FF72H•D3)

RXTRGS: Serial interface (2) receive trigger/status (FF5AH•D3)

Functions as the receive start trigger or preparation for the following data receiving and the operation status indicator (during receiving/during stop).

When "1" is read: During receiving

When "0" is read: During stop

When "1" is written: Start receiving/following data receiving preparation

When "0" is written: Invalid

RXTRG/RXTRGS has a slightly different operation in the clock synchronous system and the asynchronous system.

The RXTRG/RXTRGS in the clock synchronous system is used as the trigger for starting receive operation.

Write "1" into RXTRG/RXTRGS to start receiving at the point where the receive data has been read and the

following receive preparation has been done. (In the slave mode, $\overline{\text{SRDY}}$ becomes "0" at the point where "1" has been written into the RXTRG/RXTRGS.)

In the asynchronous system, RXTRG/RXTRGS is used for preparation of the following data receiving. Read the received data located in the receive data buffer and write "1" into RXTRG/RXTRGS to inform that the receive data buffer has shifted to empty. When "1" has not been written to RXTRG/RXTRGS, the overrun error flag OER is set to "1" at the point where the following receiving has been completed. (When the receiving has been completed between the operation to read the received data and the operation to write "1" into RXTRG/RXTRGS, an overrun error occurs.)

In addition, RXTRG/RXTRGS can be read as the status. In either clock synchronous mode or asynchronous mode, when RXTRG/RXTRGS is set to "1", it indicates receiving operation and when set to "0", it indicates that receiving has stopped.

At initial reset, RXTRG/RXTRGS is set to "0".

TRXD0–TRXD7: Serial interface (1) transmit/receive data (FF74H, FF75H)

TRXD0S–TRXD7S: Serial interface (2) transmit/receive data (FF5CH, FF5DH)

During transmitting

Transmitting data is set.

When "1" is written: High level

When "0" is written: Low level

Write the transmitting data prior to starting transmission.

In the case of continuous transmitting, wait for the transmit completion interrupt, then write the data.

The TRXD7/TRXD7S becomes invalid for the 7-bit asynchronous mode.

Converted serial data for which the bits set at "1" as High (VDD) level and for which the bits set at "0" as Low (Vss) level are output from the SOUT terminal.

During receiving

The received data is stored.

When "1" is read: High level

When "0" is read: Low level

The data from the receive data buffer can be read out.

Since the shift register is provided separately from this buffer, reading can be done during a receive operation in the asynchronous mode. (The buffer function is not used in the clock synchronous mode.)

Read the data after waiting for a receive completion interrupt.

When performing parity check in the 7-bit asynchronous mode, "0" is loaded into the 8th bit (TRXD7/TRXD7S) that corresponds to the parity bit.

The serial data input from the SIN terminal is level converted, making the High (VDD) level bit "1" and the Low (VSS) level bit "0" and is then loaded into this buffer.

At initial reset, the buffer content is undefined.

OER: Serial interface (1) overrun error flag (FF73H•D0)**OERS: Serial interface (2) overrun error flag (FF5BH•D0)**

Indicates the generation of an overrun error.

When "1" is read: Error

When "0" is read: No error

When "1" is written: Reset to "0"

When "0" is written: Invalid

OER/OERS is an error flag that indicates the generation of an overrun error and becomes "1" when an error has been generated.

An overrun error is generated when a receiving of data has completed prior to writing "1" to RXTRG/RXTRGS in the asynchronous mode.

OER/OERS is reset to "0" by writing "1".

OER/OERS is set to "0" at initial reset or when RXEN/RXENS is set to "0".

PER: Serial interface (1) parity error flag (FF73H•D1)**PERS: Serial interface (2) parity error flag (FF5BH•D1)**

Indicates the generation of a parity error.

When "1" is read: Error

When "0" is read: No error

When "1" is written: Reset to "0"

When "0" is written: Invalid

PER/PERS is an error flag that indicates the generation of a parity error and becomes "1" when an error has been generated.

When a parity check is performed in the asynchronous mode, a parity error will be generated if data that does not match the parity is received.

PER/PERS is reset to "0" by writing "1".

PER/PERS is set to "0" at initial reset or when RXEN/RXENS is set to "0".

FER: Serial interface (1) framing error flag (FF73H•D2)

FERS: Serial interface (2) framing error flag (FF5BH•D2)

Indicates the generation of a framing error.

When "1" is read: Error

When "0" is read: No error

When "1" is written: Reset to "0"

When "0" is written: Invalid

FER/FERS is an error flag that indicates the generation of a framing error and becomes "1" when an error has been generated.

When the stop bit for the receiving in the asynchronous mode has become "0", a framing error is generated.

FER/FERS is reset to "0" by writing "1".

FER/FERS is set to "0" at initial reset or when RXEN/RXENS is set to "0".

EISRC, EISTR, EISER: Serial interface (1) interrupt mask registers (FFE3H•D0, D1, D2)

EISRCS, EISTRS, EISERS: Serial interface (2) interrupt mask registers (FFE8H•D0, D1, D2)

Enables or disables the generation of an interrupt for the CPU.

When "1" is written: Enabled

When "0" is written: Disabled

Reading: Valid

EISRC/EISRCS, EISTR/EISTRS and EISER/EISERS are interrupt mask registers that respectively correspond to the interrupt factors for receive completion, transmit completion and receive error. Interrupts set to "1" are enabled and interrupts set to "0" are disabled.

At initial reset, these registers are set to "0".

ISRC, ISTR, ISER: Serial interface (1) interrupt factor flags (FFF3H•D0, D1, D2)

ISRCS, ISTRS, ISERS: Serial interface (2) interrupt factor flags (FFF8H•D0, D1, D2)

Indicates the serial interface interrupt generation status.

When "1" is read: Interrupt has occurred

When "0" is read: Interrupt has not occurred

When "1" is written: Flag is reset

When "0" is written: Invalid

ISRC/ISRCS, ISTR/ISTRS and ISER/ISERS are interrupt factor flags that respectively correspond to the interrupts for receive completion, transmit completion and receive error, and are set to "1" by generation of each factor.

Transmit completion interrupt factor is generated at the point where the data transmission of the shift register has been completed.

Receive completion interrupt factor is generated at the point where the received data has been transferred into the receive data buffer.

Receive error interrupt factor is generated when a parity error, framing error or overrun error has been detected during data receiving.

When set in this manner, if the corresponding interrupt enable mask is set to "1" and the CPU is set to interrupt enabled status (I flag = "1"), an interrupt will be generated to the CPU.

Regardless of the interrupt mask register setting, the interrupt factor flag will be set to "1" by the occurrence of an interrupt generation condition.

The interrupt factor flag is reset to "0" by writing "1".

After an interrupt occurs, the same interrupt will occur again if the interrupt enabled state (I flag = "1") is set or the RETI instruction is executed unless the interrupt factor flag is reset. Therefore, be sure to reset (write "1" to) the interrupt factor flag in the interrupt service routine before shifting to the interrupt enabled state.

At initial reset, these flags are set to "0".

4.11.10 Programming notes

- (1) Be sure to initialize the serial interface mode in the transmit/receive disabled status (TXEN = RXEN = "0").
- (2) Do not perform double trigger (writing "1" to TXTRG (RXTRG) when the serial interface is in the transmitting (receiving) operation.
- (3) In the clock synchronous mode, since one clock line ($\overline{\text{SCLK}}$) is shared for both transmitting and receiving, transmitting and receiving cannot be performed simultaneously. (Half duplex only is possible in clock synchronous mode.)
Consequently, be sure not to write "1" to RXTRG (TXTRG) when TXTRG (RXTRG) is "1".
- (4) When a parity error or framing error is generated during receiving in the asynchronous mode, the receiving error interrupt factor flag ISER is set to "1" prior to the receive completion interrupt factor flag ISRC for the time indicated in Table 4.11.10.1. Consequently, when an error is generated, you should reset the receiving complete interrupt factor flag ISRC to "0" by providing a wait time in error processing routines and similar routines.
When an overrun error is generated, the receiving complete interrupt factor flag ISRC is not set to "1" and a receiving complete interrupt is not generated.

Table 4.11.10.1 Time difference between ISER and ISRC on error generation

Clock source	Time difference
fosc3 / n	1/2 cycles of fosc3 / n
Programmable timer	1 cycle of timer 1 underflow

- (5) When the demultiplied signal of the OSC3 oscillation circuit is made the clock source, it is necessary to turn the OSC3 oscillation ON, prior to using the serial interface.
A time interval of 5 msec, from the turning ON of the OSC3 oscillation circuit to until the oscillation stabilizes, is necessary, due to the oscillation element that is used. Consequently, you should allow an adequate waiting time after turning ON of the OSC3 oscillation, before starting transmitting/receiving of serial interface. (The oscillation start time will vary somewhat depending on the oscillator and on the externally attached parts. Refer to the oscillation start time example indicated in Chapter 7, "Electrical Characteristics".)
At initial reset, the OSC3 oscillation circuit is set to OFF status.
- (6) Be aware that the maximum clock frequency for the serial interface is limited to 1 MHz.
- (7) After an interrupt occurs, the same interrupt will occur again if the interrupt enabled state (I flag = "1") is set or the RETI instruction is executed unless the interrupt factor flag is reset. Therefore, be sure to reset (write "1" to) the interrupt factor flag in the interrupt service routine before shifting to the interrupt enabled state.

4.12 Sound Generator

4.12.1 Configuration of sound generator

The S1C63558 has a built-in sound generator for generating buzzer signals. Hence, generated buzzer signals can be output from the R00 (XBZ) and R01 (BZ) terminals. Aside permitting the respective setting of the buzzer signal frequency and sound level to 8 stages, it permits the adding of a digital envelope by means of duty ratio control. It also has a one-shot output function for outputting key operated sounds. Figure 4.12.1.1 shows the configuration of the sound generator.

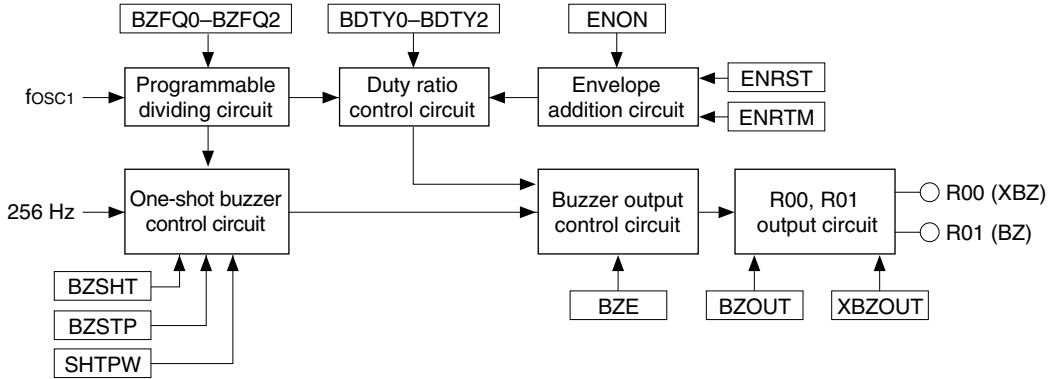

Fig. 4.12.1.1 Configuration of sound generator

4.12.2 Buzzer output circuit

The S1C63558 uses the R01 (BZ) and R00 (XBZ) terminals for outputting buzzer signals. To drive a piezoelectric buzzer with one terminal, use the BZ signal output from the R01 (BZ) terminal. The piezoelectric buzzer should be driven via a bipolar transistor. Since the R01 (BZ) terminal goes High level when the buzzer signal is stopped, use a PNP transistor as shown in Figure 4.12.2.1.

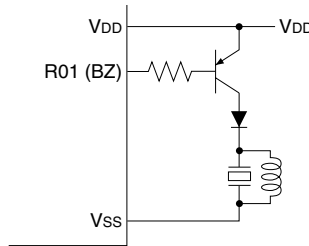

Fig. 4.12.2.1 Buzzer output circuit using the R01 (BZ) terminal

The S1C63558 allows direct driving of a piezoelectric buzzer using both the R01 (BZ) and R00 (XBZ) terminals. In this case, a piezoelectric buzzer should be connected to these terminals via protection resistors (100 Ω) as shown in Figure 4.12.2.2.

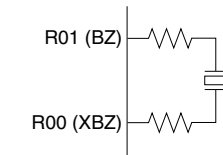

Fig. 4.12.2.2 Direct driving a piezoelectric buzzer using the R01 (BZ) and R00 (XBZ) terminals

4.12.3 Control of buzzer output

The R01 and R00 terminals for buzzer output are set as general-purpose output ports at initial reset. Therefore, the R01 terminal must be set as the BZ output terminal by writing "1" to the BZOUT register before controlling buzzer output. Furthermore, the data register R01 for the R01 output port should be fixed at "1" and the high-impedance register R01HIZ at "0".

When direct driving a piezoelectric buzzer, the R00 terminal must be set as the XBZ output terminal similar to the R01 terminal. Write "1" to the XBZOUT register to set the XBZ output. Also in this case, the data register R00 for the R00 output port should be fixed at "1" and the high-impedance register R00HIZ at "0".

The buzzer signals generated by the sound generator are output from the BZ (R01) and XBZ (R00) terminals by writing "1" to the buzzer output enable register BZE. When "0" is written to the BZE register, the BZ (R01) terminal goes High (VDD) and XBZ (R00) terminal goes Low (VSS).

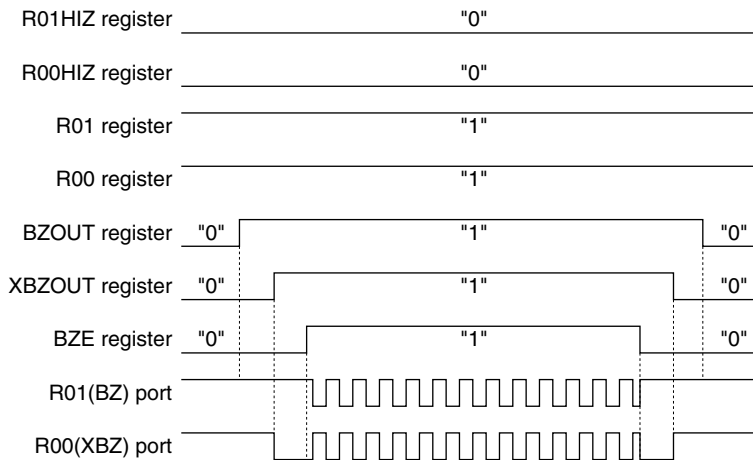

Fig. 4.12.3.1 Buzzer signal output timing chart

Note: Since the BZ and XBZ signals are generated asynchronous to the BZE register, hazards may be produced when the signal goes ON/OFF due to the setting of the BZE register.

4.12.4 Setting of buzzer frequency and sound level

The divided signal of the OSC1 oscillation clock (32.768 kHz) is used for the buzzer (BZ, XBZ) signals and it is set up such that 8 types of frequencies can be selected by changing this division ratio. Frequency selection is done by setting the buzzer frequency selection registers BZFQ0–BZFQ2 as shown in Table 4.12.4.1.

Table 4.12.4.1 Buzzer signal frequency setting

BZFQ2	BZFQ1	BZFQ0	Buzzer frequency (Hz)
0	0	0	4096.0
0	0	1	3276.8
0	1	0	2730.7
0	1	1	2340.6
1	0	0	2048.0
1	0	1	1638.4
1	1	0	1365.3
1	1	1	1170.3

The buzzer sound level is changed by controlling the duty ratio of the buzzer signal.

The duty ratio can be selected from among the 8 types shown in Table 4.12.4.2 according to the setting of the buzzer duty selection registers BDTY0–BDTY2.

Table 4.12.4.2 Duty ratio setting

Level	BDTY2	BDTY1	BDTY0	Duty ratio by buzzer frequency (Hz)			
				4096.0	3276.8	2730.7	2340.6
				2048.0	1638.4	1365.3	1170.3
Level 1 (Max.)	0	0	0	8/16	8/20	12/24	12/28
Level 2	0	0	1	7/16	7/20	11/24	11/28
Level 3	0	1	0	6/16	6/20	10/24	10/28
Level 4	0	1	1	5/16	5/20	9/24	9/28
Level 5	1	0	0	4/16	4/20	8/24	8/28
Level 6	1	0	1	3/16	3/20	7/24	7/28
Level 7	1	1	0	2/16	2/20	6/24	6/28
Level 8 (Min.)	1	1	1	1/16	1/20	5/24	5/28

When the HIGH level output time has been made TH and when the LOW level output time has been made TL due to the ratio of the pulse width to the pulse synchronization, the duty ratio becomes $TL/(TH+TL)$ for negative polarity or $TH/(TH+TL)$ for positive polarity.

When BDTY0–BDTY2 have all been set to "0", the duty ratio becomes maximum and the sound level also becomes maximum. Conversely, when BDTY0–BDTY2 have all been set to "1", the duty ratio becomes minimum and the sound level also becomes minimum.

The duty ratio that can be set is different depending on the frequency that has been set, so see Table 4.12.4.2.

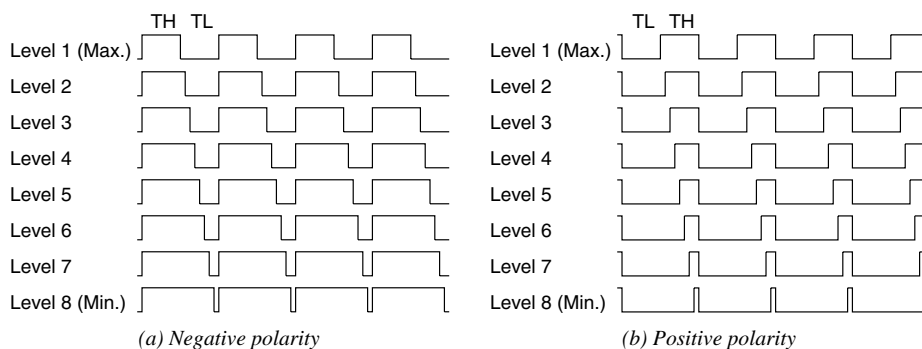

Fig. 4.12.4.1 Duty ratio of the buzzer signal waveform

Note: When a digital envelope has been added to the buzzer signal, the BDTY0–BDTY2 settings will be invalid due to the control of the duty ratio.

4.12.5 Digital envelope

A digital envelope for duty control can be added to the buzzer signal.

The envelope can be controlled by staged changing of the same duty envelope as detailed in Table 4.12.4.2 in the preceding item from level 1 (maximum) to level 8 (minimum).

The addition of an envelope to the buzzer signal can be done by writing "1" into ENON, but when "0" has been written it is not added.

When a buzzer signal output is begun (writing "1" into BZE) after setting ENON, the duty ratio shifts to level 1 (maximum) and changes in stages to level 8.

When attenuated down to level 8 (minimum), it is retained at that level. The duty ratio can be returned to maximum, by writing "1" into register ENRST during output of a envelope attached buzzer signal.

The envelope attenuation time (time for changing of the duty ratio) can be selected by the register ENRTM. The time for a 1 stage level change is 62.5 msec (16 Hz), when "0" has been written into ENRTM and 125 msec (8 Hz), when to "1" has been written. However, there is also a max. 4 msec error from envelope ON, up to the first change.

Figure 4.12.5.1 shows the timing chart of the digital envelope.

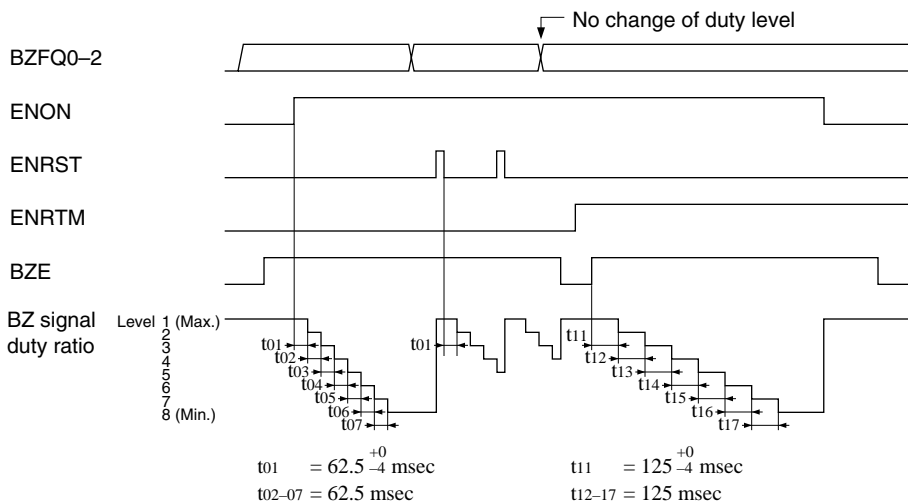

Fig. 4.12.5.1 Timing chart for digital envelope

4.12.6 One-shot output

The sound generator has a one-shot output function for outputting a short duration buzzer signal for key operation sounds and similar effects. Either 125 msec or 31.25 msec can be selected by SHTPW register for one-shot buzzer signal output time.

The output of the one-shot buzzer is controlled by writing "1" into the one-shot buzzer trigger BZSHT. When this trigger has been assigned, a buzzer signal in synchronization with the internal 256 Hz signal is output from the BZ and XBZ terminals. Thereafter, when the set time has elapsed, a buzzer signal in synchronization with the 256 Hz signal goes off in the same manner as for the start of output.

The BZSHT also permits reading. When BZSHT is "1", the one-shot output circuit is in operation (during one-shot output) and when it is "0", it shows that the circuit is in the ready (outputtable) status.

In addition, it can also terminate one-shot output prior to the elapsing of the set time. This is done by writing a "1" into the one-shot buzzer stop BZSTP. In this case as well, the buzzer signal goes OFF in synchronization with the 256 Hz signal.

When "1" is written to BZSHT again during a one-shot output, a new one-shot output for 125 msec or 31.25 msec starts from that point (in synchronization with the 256 Hz signal).

The one-shot output cannot add an envelope for short durations. However, the sound level can be set by selecting the duty ratio, and the frequency can also be set.

One-shot output is invalid during normal buzzer output (during BZE = "1").

Figure 4.12.6.1 shows timing chart for one-shot output.

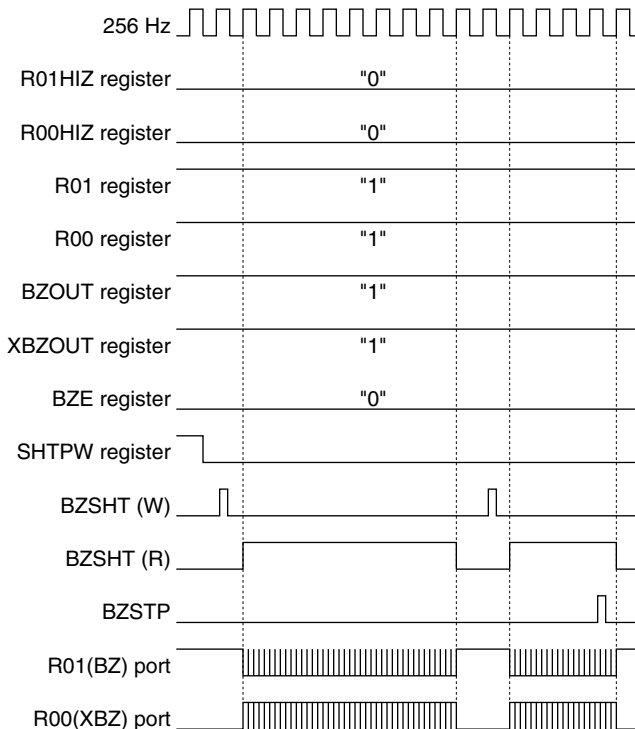

Fig. 4.12.6.1 Timing chart for one-shot output

4.12.7 I/O memory of sound generator

Table 4.12.7.1 shows the I/O addresses and the control bits for the sound generator.

Table 4.12.7.1 Control bits of sound generator

Address	Register								Comment																				
	D3	D2	D1	D0	Name	Init *1	1	0																					
FF30H	R03HIZ	R02HIZ	R01HIZ	R00HIZ	R03HIZ	0	Hi-Z	Output	R03 (FOUTE=0)/FOUT (FOUTE=1) Hi-z control																				
					R02HIZ	0	Hi-Z	Output	R02 (PTOUT=0)/TOUT (PTOUT=1) Hi-z control																				
	R/W				R01HIZ	0	Hi-Z	Output	R01 (BZOUT=0)/BZ (BZOUT=1) Hi-z control																				
					R00HIZ	0	Hi-Z	Output	R00 (XBZOUT=0)/XBZ (XBZOUT=1) Hi-z control																				
FF31H	R03 (FOUT)	R02 (TOUT)	R01 (BZ)	R00 (XBZ)	R03	1	High	Low	R03 output port data (FOUTE=0) Fix at "1" when FOUT is used.																				
					R02	1	High	Low	R02 output port data (PTOUT=0) Fix at "1" when TOUT is used.																				
	R/W				R01	1	High	Low	R01 output port data (BZOUT=0) Fix at "1" when BZ is used.																				
					R00	1	High	Low	R00 output port data (XBZOUT=0) Fix at "1" when XBZ is used.																				
FF65H	0	0	BZOUT	XBZOUT	0 *3	- *2			Unused																				
					0 *3	- *2			Unused																				
	R		R/W		BZOUT	0	BZ	DC	R01 output selection (R01 should be fixed at "1".)																				
					XBZOUT	0	XBZ	DC	R00 output selection (R00 should be fixed at "1".)																				
FF6CH	ENRTM	ENRST	ENON	BZE	ENRTM	0	1sec	0.5sec	Envelope releasing time selection																				
					ENRST*3	Reset	Reset	Invalid	Envelope reset (writing)																				
	R/W	W	R/W		ENON	0	On	Off	Envelope On/Off																				
					BZE	0	Enable	Disable	Buzzer output enable																				
FF6DH	0	BZSTP	BZSHT	SHTPW	0 *3	- *2			Unused																				
					BZSTP*3	0	Stop	Invalid	1-shot buzzer stop (writing)																				
	R	W	R/W		BZSHT	0	Trigger	Invalid	1-shot buzzer trigger (writing)																				
					SHTPW	0	Busy	Ready	1-shot buzzer status (reading)																				
FF6EH	0	BZSQ2	BZSQ1	BZSQ0	0 *3	- *2			Unused																				
					BZSQ2	0			Buzzer frequency selection <table border="1"> <tr> <td>[BZSQ2, 1, 0]</td> <td>0</td> <td>1</td> <td>2</td> <td>3</td> </tr> <tr> <td>Frequency (Hz)</td> <td>4096.0</td> <td>3276.8</td> <td>2730.7</td> <td>2340.6</td> </tr> <tr> <td>[BZSQ2, 1, 0]</td> <td>4</td> <td>5</td> <td>6</td> <td>7</td> </tr> <tr> <td>Frequency (Hz)</td> <td>2048.0</td> <td>1638.4</td> <td>1365.3</td> <td>1170.3</td> </tr> </table>	[BZSQ2, 1, 0]	0	1	2	3	Frequency (Hz)	4096.0	3276.8	2730.7	2340.6	[BZSQ2, 1, 0]	4	5	6	7	Frequency (Hz)	2048.0	1638.4	1365.3	1170.3
	[BZSQ2, 1, 0]	0	1	2	3																								
	Frequency (Hz)	4096.0	3276.8	2730.7	2340.6																								
[BZSQ2, 1, 0]	4	5	6	7																									
Frequency (Hz)	2048.0	1638.4	1365.3	1170.3																									
R	R/W			BZSQ1	0																								
				BZSQ0	0																								
FF6FH	0	BDTY2	BDTY1	BDTY0	0 *3	- *2			Unused																				
					BDTY2	0			Buzzer signal duty ratio selection (refer to main manual)																				
	R	R/W			BDTY1	0																							
					BDTY0	0																							

*1 Initial value at initial reset

*2 Not set in the circuit

*3 Constantly "0" when being read

R00HIZ, R01HIZ: R00, R01 port high impedance control register (FF30H•D0, D1)

Controls high impedance output of the output port.

When "1" is written: High impedance

When "0" is written: Data output

Reading: Valid

When using the BZ and XBZ outputs, fix the registers at "0". R01HIZ corresponds to the BZ output and R00HIZ corresponds to the XBZ output.

At initial reset, these registers are set to "0".

R00, R01: R00, R01 output port data register (FF31H• D0, D1)

Set the output data for the output ports.

When "1" is written: High level output

When "0" is written: Low level output

Reading: Valid

When using the BZ and XBZ outputs, fix the registers at "1". R01 corresponds to the BZ output and R00 corresponds to the XBZ output.

At initial reset, these registers are all set to "1".

XBZOUT: R00 output selection register (FF65H•D0)

Selects the R00 terminal function.

- When "1" is written: XBZ output
- When "0" is written: General-purpose DC output
- Reading: Valid

When using the R00 terminal for the XBZ output, write "1" to this register. Furthermore, fix the R00 register at "1" and the R00HIZ register at "0".

At initial reset, this register is set to "0".

BZOUT: R01 output selection register (FF65H•D1)

Selects the R01 terminal function.

- When "1" is written: BZ output
- When "0" is written: General-purpose DC output
- Reading: Valid

When using the R01 terminal for the BZ output, write "1" to this register. Furthermore, fix the R01 register at "1" and the R01HIZ register at "0".

At initial reset, this register is set to "0".

BZE: BZ output control register (FF6CH•D0)

Controls the buzzer signal output.

- When "1" is written: Buzzer output ON
- When "0" is written: Buzzer output OFF
- Reading: Valid

When "1" is written to BZE, the BZ signal is output from the BZ (R01) terminal and the XBZ signal is output from the XBZ (R00) terminal.

When "0" is written, the buzzer signals go OFF.

At initial reset, this register is set to "0".

BZFQ0–BZFQ2: Buzzer frequency selection register (FF6EH•D0–D2)

Selects the buzzer signal frequency.

Table 4.12.7.2 Buzzer signal frequency setting

BZFQ2	BZFQ1	BZFQ0	Buzzer frequency (Hz)
0	0	0	4096.0
0	0	1	3276.8
0	1	0	2730.7
0	1	1	2340.6
1	0	0	2048.0
1	0	1	1638.4
1	1	0	1365.3
1	1	1	1170.3

Select the buzzer frequency from among the above 8 types that have divided the oscillation clock.

At initial reset, this register is set to "0".

BDTY0–BDTY2: Duty level selection register (FF6FH•D0–D2)

Selects the duty ratio of the buzzer signal as shown in Table 4.12.7.3.

Table 4.12.7.3 Duty ratio setting

Level	BDTY2	BDTY1	BDTY0	Duty ratio by buzzer frequency (Hz)			
				4096.0 2048.0	3276.8 1638.4	2730.7 1365.3	2340.6 1170.3
Level 1 (Max.)	0	0	0	8/16	8/20	12/24	12/28
Level 2	0	0	1	7/16	7/20	11/24	11/28
Level 3	0	1	0	6/16	6/20	10/24	10/28
Level 4	0	1	1	5/16	5/20	9/24	9/28
Level 5	1	0	0	4/16	4/20	8/24	8/28
Level 6	1	0	1	3/16	3/20	7/24	7/28
Level 7	1	1	0	2/16	2/20	6/24	6/28
Level 8 (Min.)	1	1	1	1/16	1/20	5/24	5/28

The sound level of this buzzer can be set by selecting this duty ratio.

However, when the envelope has been set to ON (ENON = "1"), this setting becomes invalid.

At initial reset, this register is set to "0".

ENRST: Envelope reset (FF6CH•D2)

Resets the envelope.

When "1" is written: Reset

When "0" is written: No operation

Reading: Always "0"

Writing "1" into ENRST resets envelope and the duty ratio becomes maximum. If an envelope has not been added (ENON = "0") and if no buzzer signal is being output, the reset becomes invalid. Writing "0" is also invalid.

This bit is dedicated for writing, and is always "0" for reading.

ENON: Envelope ON/OFF control register (FF6CH•D1)

Controls the addition of an envelope onto the buzzer signal.

When "1" is written: ON

When "0" is written: OFF

Reading: Valid

Writing "1" into the ENON causes an envelope to be added during buzzer signal output. When a "0" has been written, an envelope is not added.

At initial reset, this register is set to "0".

ENRTM: Envelope releasing time selection register (FF6CH•D3)

Selects the envelope releasing time that is added to the buzzer signal.

When "1" is written: 1.0 sec (125 msec × 7 = 875 msec)

When "0" is written: 0.5 sec (62.5 msec × 7 = 437.5 msec)

Reading: Valid

The releasing time of the digital envelope is determined by the time for converting the duty ratio.

When "1" has been written in ENRTM, it becomes 125 msec (8 Hz) units and when "0" has been written, it becomes 62.5 msec (16 Hz) units.

At initial reset, this register is set to "0".

SHTPW: One-shot buzzer pulse width setting register (FF6DH•D0)

Selects the output time of the one-shot buzzer.

- When "1" is written: 125 msec
- When "0" is written: 31.25 msec
- Reading: Valid

Writing "1" into SHTPW causes the one-short output time to be set at 125 msec, and writing "0" causes it to be set to 31.25 msec. It does not affect normal buzzer output.

At initial reset, this register is set to "0".

BZSHT: One-shot buzzer trigger/status (FF6DH•D1)

Controls the one-shot buzzer output.

• *When writing*

- When "1" is written: Trigger
- When "0" is written: No operation

Writing "1" into BZSHT causes the one-short output circuit to operate and a buzzer signal to be output. This output is automatically turned OFF after the time set by SHTPW has elapsed. The one-shot output is only valid when the normal buzzer output is OFF (BZE = "0") and will be invalid when the normal buzzer output is ON (BZE = "1"). When a re-trigger is assigned during a one-shot output, the one-shot output time set with SHTPW is measured again from that point (time extension).

• *When reading*

- When "1" is read: BUSY
- When "0" is read: READY

During reading BZSHT shows the operation status of the one-shot output circuit. During one-shot output, BZSHT becomes "1" and the output goes OFF, it shifts to "0".

At initial reset, this bit is set to "0".

BZSTP: One-shot buzzer stop (FF6DH•D2)

Stops the one-shot buzzer output.

- When "1" is written: Stop
- When "0" is written: No operation
- Reading: Always "0"

Writing "1" into BZSTP permits the one-shot buzzer output to be turned OFF prior to the elapsing of the time set by SHTPW. Writing "0" is invalid and writing "1" is also invalid except during one-shot output. This bit is dedicated for writing, and is always "0" for reading.

4.12.8 Programming notes

- (1) Since the BZ and XBZ signals are generated asynchronous to the BZE register, hazards may be produced when the signal goes ON/OFF due to the setting of the BZE register.
- (2) The one-shot output is only valid when the normal buzzer output is OFF (BZE = "0") and will be invalid when the normal buzzer output is ON (BZE = "1").
- (3) Since the BZ and XBZ signals are the special outputs of the R01 and R00 ports, it is necessary to set the high impedance control registers (R01HIZ, R00HIZ) to "0", the data registers (R01, R00) to "1" and the output selection registers (BZOUT, XBZOUT) to "1" before setting the BZE register to "1".

4.13 SVD (Supply Voltage Detection) Circuit

4.13.1 Configuration of SVD circuit

The S1C63558 has a built-in SVD (supply voltage detection) circuit, so that the software can find when the source voltage lowers. It is possible to check an external voltage drop, other than the supply voltage, by mask option.

Turning the SVD circuit ON/OFF and the SVD criteria voltage setting can be done with software.

Figure 4.13.1.1 shows the configuration of the SVD circuit.

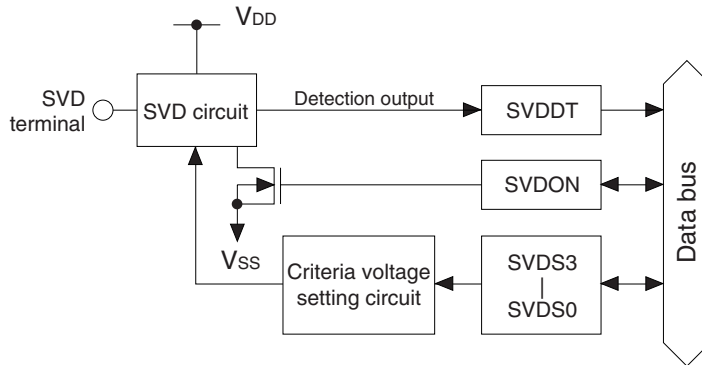

Fig. 4.13.1.1 Configuration of SVD circuit

4.13.2 Mask option

Besides the supply voltage (VDD terminal–VSS terminal) drop detection, the SVD circuit can detect the external voltage (SVD terminal–VSS terminal) input from the SVD terminal by comparing it with the detected voltage (1.05 V). This function can select whether or not to use with the mask option.

4.13.3 SVD operation

The SVD circuit compares the criteria voltage set by software and the supply voltage (VDD terminal–VSS terminal) or the external voltage (SVD terminal–VSS terminal) and sets its results into the SVDDT latch. By reading the data of this SVDDT latch, it can be determined by means of software whether the supply voltage is normal or has dropped.

The criteria voltage can be set for the 12 types shown in Table 4.13.3.1 by the SVDS3–SVDS0 registers. When "0" is written to the SVDS3–SVDS0 register, the supply voltage detection voltage is set to 2.20 V. However, when "External voltage detection" is selected by mask option, the SVD circuit does not compare the supply voltage (VDD terminal–VSS terminal) but compares between the external voltage (SVD terminal–VSS terminal) input from the SVD terminal and 1.05 V.

Table 4.13.3.1 Criteria voltage setting

SVDS3	SVDS2	SVDS1	SVDS0	Criteria voltage (V)	SVDS3	SVDS2	SVDS1	SVDS0	Criteria voltage (V)
0	1	1	1	2.50	1	1	1	1	3.30
0	1	1	0	2.40	1	1	1	0	3.20
0	1	0	1	2.30	1	1	0	1	3.10
0	1	0	0	2.20	1	1	0	0	3.00
0	0	1	1	2.20	1	0	1	1	2.90
0	0	1	0	2.20	1	0	1	0	2.80
0	0	0	1	2.20	1	0	0	1	2.70
0	0	0	0	2.20/1.05	1	0	0	0	2.60

When the SVDON register is set to "1", source voltage or external voltage detection by the SVD circuit is executed. As soon as the SVDON register is reset to "0", the result is loaded to the SVDDT latch and the SVD circuit goes OFF.

To obtain a stable detection result, the SVD circuit must be ON for at least 100 µsec. So, to obtain the SVD detection result, follow the programming sequence below.

1. Set SVDON to "1"
2. Maintain for 100 µsec minimum
3. Set SVDON to "0"
4. Read SVDDT

When the SVD circuit is ON, the IC draws a large current, so keep the SVD circuit off unless it is.

4.13.4 I/O memory of SVD circuit

Table 4.13.4.1 shows the I/O addresses and the control bits for the SVD circuit.

Table 4.13.4.1 Control bits of SVD circuit

Address	Register				Name	Init *1	1	0	Comment
	D3	D2	D1	D0					
FF04H	SVDS3	SVDS2	SVDS1	SVDS0	SVDS3	0			SVD criteria voltage setting [SVDS3-0] 0 1 2 3 4 5 6 7 Voltage(V) 2.20/1.05 2.20 2.20 2.20 2.20 2.30 2.40 2.50 [SVDS3-0] 8 9 10 11 12 13 14 15 Voltage(V) 2.60 2.70 2.80 2.90 3.00 3.10 3.20 3.30
	R/W				SVDS2	0			
	R/W				SVDS1	0			
	R/W				SVDS0	0			
	R/W				SVDS0	0			
FF05H	0	0	SVDDT	SVDON	0 *3	- *2			Unused
	R				0 *3	- *2			Unused
	R			R/W	SVDDT	0	Low	Normal	SVD evaluation data
	R			R/W	SVDON	0	On	Off	SVD circuit On/Off

- *1 Initial value at initial reset
- *2 Not set in the circuit
- *3 Constantly "0" when being read

SVDS3–SVDS0: SVD criteria voltage setting register (FF04H)

Criteria voltage for SVD is set as shown in Table 4.13.3.1. At initial reset, this register is set to "0".

SVDON: SVD control (ON/OFF) register (FF05H•D0)

Turns the SVD circuit ON and OFF.

- When "1" is written: SVD circuit ON
- When "0" is written: SVD circuit OFF
- Reading: Valid

When the SVDON register is set to "1", a source voltage detection is executed by the SVD circuit. As soon as SVDON is reset to "0", the result is loaded to the SVDDT latch. To obtain a stable detection result, the SVD circuit must be ON for at least 100 µsec.

At initial reset, this register is set to "0".

SVDDT: SVD data (FF05H•D1)

This is the result of supply voltage detection.

- When "0" is read: Supply voltage (VDD–VSS) ≥ Criteria voltage
- When "1" is read: Supply voltage (VDD–VSS) < Criteria voltage
- Writing: Invalid

The result of supply voltage detection at time of SVDON is set to "0" can be read from this latch. At initial reset, SVDDT is set to "0".

4.13.5 Programming notes

- (1) To obtain a stable detection result, the SVD circuit must be ON for at least 100 μ sec. So, to obtain the SVD detection result, follow the programming sequence below.
 1. Set SVDON to "1"
 2. Maintain for 100 μ sec minimum
 3. Set SVDON to "0"
 4. Read SVDDT
- (2) The SVD circuit should normally be turned OFF because SVD operation increase current consumption.

4.14 Telephone Function (Tone/Pulse Dialer)

4.14.1 Configuration of tone/pulse dialer

The S1C63558 has a telephone function built-in. This function includes DTMF (Dual Tone Multi-Frequency), DP (Dialing pulse), Pause, Flash, Hold-line, Mute control, Hook switch control and Handfree control.

The configuration of the telephone function is shown in Figure 4.14.1.1.

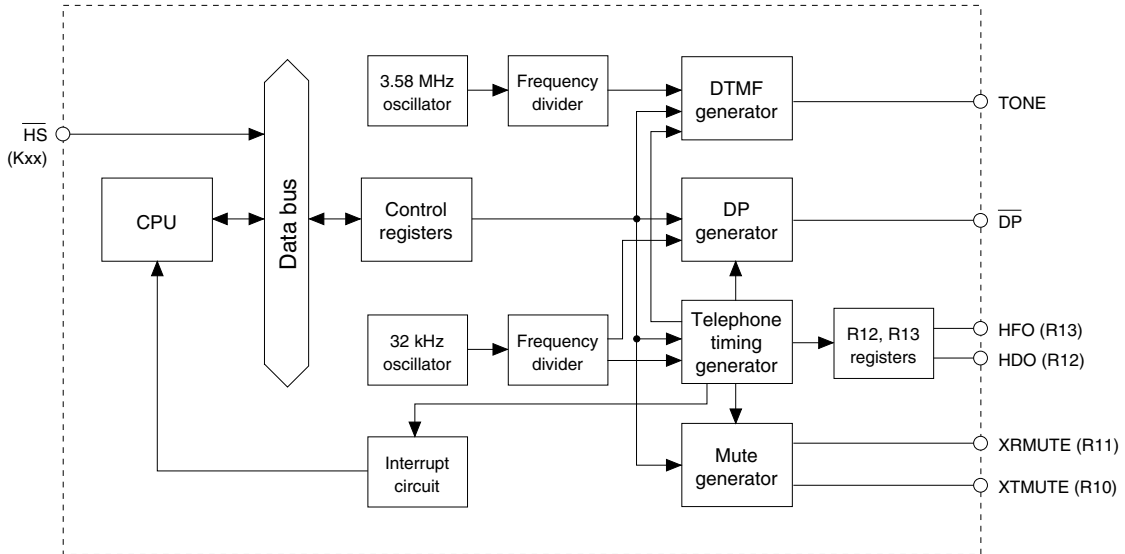

Fig. 4.14.1.1 Configuration of tone/pulse dialer

This dialer has built-in a DTMF generator for generating tones and a DP generator for generating dial pulses.

Either DTMF mode or DP mode can be selected by software.

In the DTMF mode, the DTMF generator uses the OSC3 (3.58 MHz) clock to generate the tone signal set by software (signal tone or dual tone) and outputs it to the TONE terminal.

In the DP mode, the DP generator uses the OSC1 (32 kHz) clock to generate the dial pulses for the number set by software to the \overline{DP} terminal.

The push button matrix is configured using the input and output ports. The hook switch should be connected to an input port. The hook switch can be controlled by software, this makes it possible to start calling even if the telephone is on-hook.

Besides the above terminals, The R10 to R13 terminals can be used as an XTMUTE (transmitter mute signal output), XRMUTE (receiver mute signal output), HDO (hold line signal output) and HFO (hand free signal output). These terminal functions can be configured by software. (See Section 4.5, "Output Port".)

This dialer has a built-in interrupt circuit that can generate an interrupt when execution of a dial signal output, a pause function or a flash function is completed.

4.14.2 Mask option

Output specifications for the \overline{DP} terminal is selected from between complementary output and Nch open drain output by mask option.

Since the R10 to R13 terminals are used for XTMUTE, XRMUTE, HDO and HFO outputs, the output specifications of the output ports R10–R13 apply to their output specifications. Either complementary output or Nch open drain output can be selected for each terminal by the output port mask option. However, even when Nch open drain output is selected, voltage exceeding source voltage must not be applied to the output terminals.

4.14.3 Operation of telephone function

To realize the operation of the telephone function, dialing procedure is the most important concept. This procedure contains three steps: (1) setting, (2) executing and (3) interrupt.

(1) Setting

Every function has its control registers. It is necessary to set the appropriate control registers before execution. Table 4.14.3.1 lists the relations of functions and control registers.

Table 4.14.3.1 Control registers and default setting

Function	Control register	Initial setting
DTMF	TPS (FF10H•D3)	Tone mode
	SINC, SINR (FF16H)	Dual tone
DP	TPS (FF10H•D3)	Tone mode
	MB (FF10H•D1)	40 : 60
	DRS (FF10H•D0)	10 pps
	IDP3–IDP0 (FF15H)	750 ms
PAUSE	PTS3–PTS0 (FF11H)	4 sec
FLASH	FTS3–FTS0 (FF12H)	563 ms

See Section 4.14.10, "I/O memory of telephone function", for details of each control register.

Operating mode

This dialer has built-in a DTMF generator for generating tones and a DP generator for generating dial pulses. Two basic operating modes are provided: tone mode and pulse mode. The mode can be switched by software (TPS register). This setting must be performed prior to the dial processing. At initial reset, tone mode is set.

The following operating condition should be set according to the operating mode:

- Tone mode: • Selecting single tone or dual tone output
- Pulse mode: • Setting a make ratio (40:60 or 33.3:66.6)
- Setting a pulse rate (10 pps or 20 pps)
- Setting an inter digit pause time (94 msec to 1,406 msec; selected from among 15 types)

Details will be discussed later.

The tone mode uses the OSC3 (3.58 MHz) clock, so the OSC3 oscillation must be turned ON (OSCC = "1") prior to dialing. However, it is not necessary to switch the CPU system clock to OSC3.

When executing the pause or flash function, the period of time should be set.

Pause time: 1 to 15 sec (1-sec units; selected from among 15 types)

Flash time: 94 msec to 1,406 msec (selected from among 15 types)

Furthermore, to use the R10 to R13 terminals for the XTMUTE, XRMUTE, HDO and HFO outputs, the output port functions must be switched to the dialer using the CTMO, CRMO, CHDO and CHFO registers (by writing "1"). This switching should be followed the procedure shown in Figure 4.14.3.1 (sample XTMUTE and XRMUTE outputs). The high impedance control registers (R10HIZ–R13HIZ) must be fixed at "0" and the data registers (R10–R13) at "1" before writing "1" to the CTMO, CRMO, CHDO and CHFO registers. Also the mute control registers (CTMUT, CRMUT) should be set to "1".

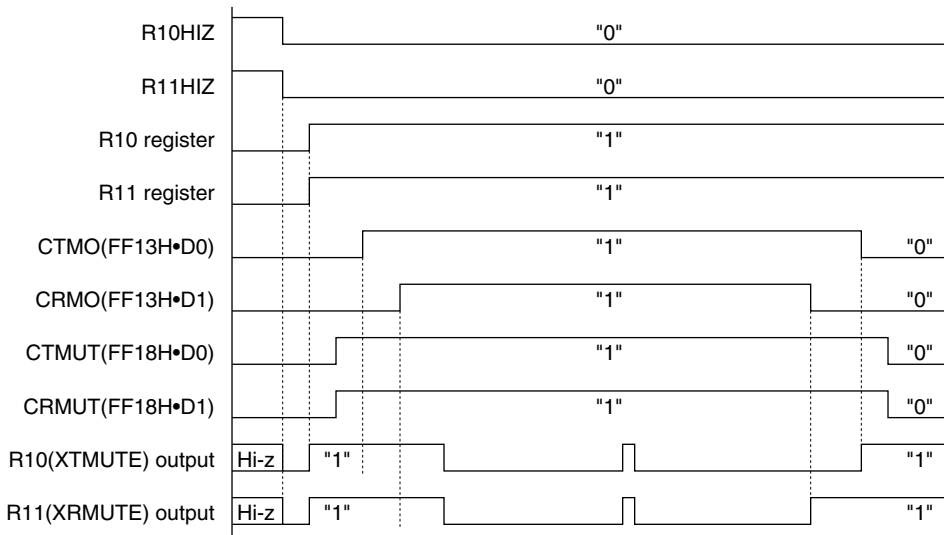

Fig. 4.14.3.1 Output terminal setting procedure

(2) Executing

After setting, write the corresponding control register to start the execution.

Table 4.14.3.2 lists control registers for executing.

Table 4.14.3.2 Control registers and executing function

Functions	Control registers	Executing function
DTMF	TCD3–TCD0 (FF17H)	Dialing tone
	CTO (FF16H•D3)	Continuous tone output ON/OFF
	HSON (FF18H•D3)	Hook switch ON/OFF
DP	TCD3–TCD0 (FF17H)	Dialing pulse
	HSON (FF18H•D3)	Hook switch ON/OFF
Pause	PAUSE (FF14H•D1)	Pause
Flash	FLASH (FF14H•D0)	Flash
Hold-line	HOLD (FF14H•D2)	Hold-line
Handfree	HF (FF14H•D3)	Handfree

See Section 4.14.10, "I/O memory of telephone function", for details of each control register.

The hook switch (HSON), continuous tone output (CTO), hold-line (HOLD) and handfree (HF) functions and their timings are controlled by software. These functions do not generate interrupts.

The HSON that controls the hook switch must be turned ON (off-hook) before executing the telephone function. Actual handset operations are not taken into the dialer. The HSON register allows on-hook dialing. The hook switch should be connected to an input port (Kxx) and get the switch status using an input interrupt.

By setting data for the dial number (1 digit) to the TCD register after setting HSON to off-hook, the dialer output the dialing tone or dialing pulses according to the condition set in (1). When the output is completed, an interrupt occurs. Use the interrupt for setting the next digit number.

The pause and flash functions are executed by writing "1" to the PAUSE and FLASH bits and will generate an interrupt after the period of time set in (1) has passed. It is not necessary to turn the function OFF.

(3) Interrupt

The dialing, pause and flash functions generate an interrupt when their operation has finished. At this time, the interrupt factor flag ID (FFF9H•D0) is set to "1". An interrupt request to the CPU will be generated when the interrupt mask register EID (FFE9H•D0) is set to "1" and will be masked when EID is set to "0". However, the interrupt factor flag ID will be set to "1" when the above function has completed even if the interrupt is masked. The end of operations can also be checked by scanning the ID flag. The ID flag is reset to "0" by writing "1". The ID flag must be cleared to "0" before starting the next interrupt.

Figure 4.14.3.2 shows an example of dialing pulse transmission procedure.

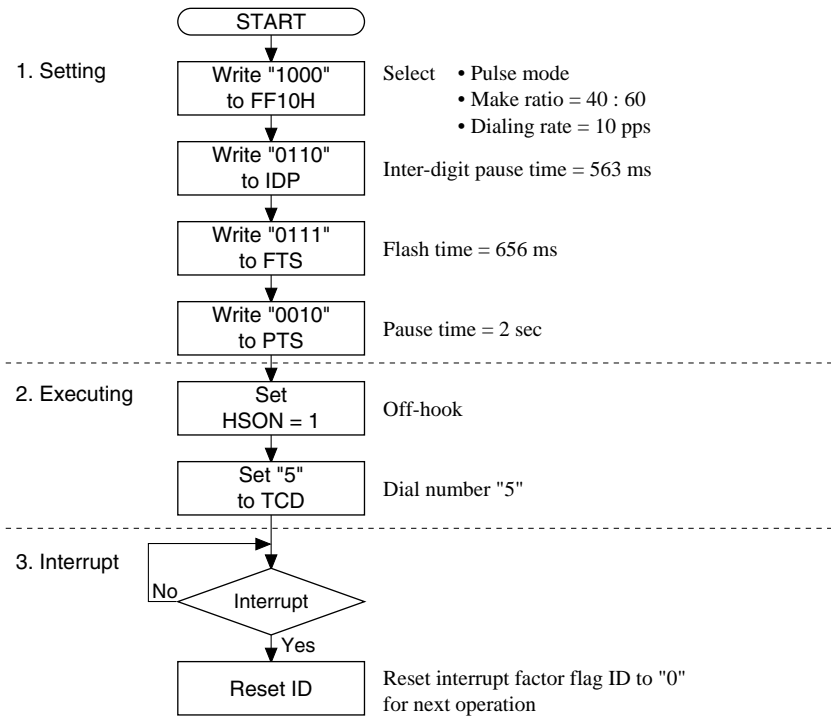

Fig. 4.14.3.2 Flow chart of dialing pulse transmission

In the setting step, "1000B" is written to address FF10H to set pulse (DP) mode, the make ratio = 40:60 and the dialing rate = 10 pps. Then data is written to IDP (FF15H), PTS (FF11H) and FTS (FF12H) to set an inter-digit pause time, pause time and flash time. These settings are not necessary when using the initial set values of IDP, PTS and FTS.

In the executing step, "1" is written to HSON (FF18H•D3) to set off-hook. This makes the \overline{DP} terminal go to a High (VDD) level and connects the telephone line. Then "0101B" (dialling number = 5) is written to TCD (FF17H) to start the dialing operation. The \overline{DP} terminal outputs 5 pulses according to the condition set. At the same time, the XTMUTE and XRMUTE signals become active (if the R10 and R11 terminals have been set as those signal output ports). In the actual application, this step should include the processing for fetching the hook switch status and for push button inputs.

When a series of pulses has been transmitted, an interrupt occurs. The next digit process can be started after resetting (writing "1" to) the interrupt factor flag ID.

4.14.4 Tone mode (DTMF)

In tone mode, the dialer outputs a tone (pushbutton dial) signal. This mode is set by default at initial reset. To change the mode from pulse mode to this mode, write "0" to the TPS register (FF10H•D3). The PB (tone) signal generates two different frequencies that are determined by the pushed button in the push button matrix as shown in Table 4.14.4.1.

Table 4.14.4.1 PB frequency combination

Frequency (Hz)	COL1 1209	COL2 1336	COL3 1477	COL4 1633
ROW1 697	1	2	3	Unused
ROW2 770	4	5	6	Unused
ROW3 852	7	8	9	Unused
ROW4 941	*	0	#	Unused

The row and column frequencies and the compound tone signal are generated by the DTMF (Dual Tone Multi-Frequency) generator. Figure 4.14.4.1 shows the block diagram of the DTMF generator.

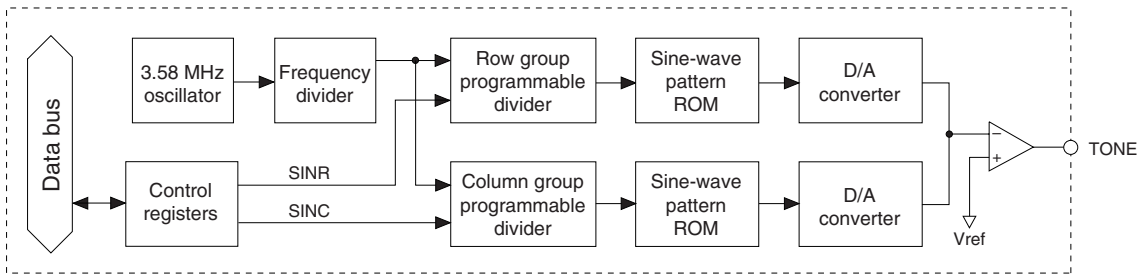

Fig. 4.14.4.1 DTMF generator block diagram

As shown in Figure 4.14.4.1, the DTMF generator generates each frequency by dividing the OSC3 (3.58 MHz) clock. Therefore, the OSC3 oscillation circuit must be turned ON before using the DTMF generator (it is not necessary to switch the CPU system clock to OSC3). Two frequency dividers are provided for the row group and column group. The actual generated frequencies are listed in Table 4.14.4.2. They may include an error within tolerance due to the dividing method.

Table 4.14.4.2 Standard vs actual frequency

ROW/COL	Tone output frequency (Hz)		Error (%) *
	Standard	Actual	
ROW1	697	701.32	+0.62
ROW2	770	771.45	+0.19
ROW3	852	857.17	+0.61
ROW4	941	935.10	-0.63
COL1	1209	1215.88	+0.57
COL2	1336	1331.68	-0.32
COL3	1477	1471.85	-0.35
COL4	1633	1645.01	+0.74

* Errors (%) do not include oscillator drift.

The row group and column group dividers can be operated individually. The software can select one of them to output a single tone signal as well as a dual tone signal output. Use the SINR (FF16H•D1) and SINC (FF16H•D0) registers for this control.

Table 4.14.4.3 Tone output selection

Control register		Tone output
SINR	SINC	
0	0	DC level: 1/2 (VDD–VSS)
0	1	COL frequency
1	0	ROW frequency
1	1	Dual tone output

At initial reset, dual tone output is set.

The divided frequencies are converted into a tone signal through the sine-wave ROM and the D/A converter, then the tone signal is output from the TONE terminal.

The items to set before outputting a tone signal may be summarized as follows:

1. Setting tone mode ... It is not necessary if the mode has not be changed after an initial reset.
2. Selecting a tone output method (single tone/dual tone) ... SINR and SINC are used.
3. Turning the OSC3 oscillation circuit ON (OSCC = "1") ... Note

Note: The OSC3 oscillation needs at least 5 msec until it is stabilized after the OSC3 oscillation circuit is turned ON. Therefore, dialing operations must be started after taking an interval of at least 5 msec from activation of the OSC3 oscillation circuit. Since the oscillation stabilization time varies depending on the external oscillator's characteristic and operating conditions, allow ample margin for the interval.

Further the OSC3 oscillation circuit increases current consumption, so it should be turned OFF when the DTMF generator is not used or the CPU does not need high-speed processing.

The following explains how to output the tone signal and the circuit operation.

First, write "1" to the HSON register (FF18H•D3) so the dialer is in off-hook status. As a result, the \overline{DP} terminal goes High (VDD) level.

Next, write the ROW/COL data of the pushbutton to be transmitted to the TCD3–TCD0 register (FF17H). Table 4.14.4.4 shows the relationship of write data and tone frequencies.

Table 4.14.4.4 Tone frequency selection

TCD code				Tone frequency	Key symbol	TCD code				Tone frequency	Key symbol
D3	D2	D1	D0			D3	D2	D1	D0		
0	0	0	0	(ROW1, COL4)	"A"	1	0	0	0	(ROW3, COL2)	"8"
0	0	0	1	(ROW1, COL1)	"1"	1	0	0	1	(ROW3, COL3)	"9"
0	0	1	0	(ROW1, COL2)	"2"	1	0	1	0	(ROW4, COL2)	"0"
0	0	1	1	(ROW1, COL3)	"3"	1	0	1	1	(ROW4, COL3)	"#"
0	1	0	0	(ROW2, COL1)	"4"	1	1	0	0	(ROW4, COL1)	"*"
0	1	0	1	(ROW2, COL2)	"5"	1	1	0	1	(ROW2, COL4)	"B"
0	1	1	0	(ROW2, COL3)	"6"	1	1	1	0	(ROW4, COL4)	"D"
0	1	1	1	(ROW3, COL1)	"7"	1	1	1	1	(ROW3, COL4)	"C"

Writing data to this register triggers the start of the tone output. When single tone output is selected, either the ROW frequency or COL frequency corresponding to the written data is output as a tone signal. When dual tone output is selected, the specified ROW and COL frequencies are output after they are composed.

Figure 4.14.4.2 shows a timing chart for tone output.

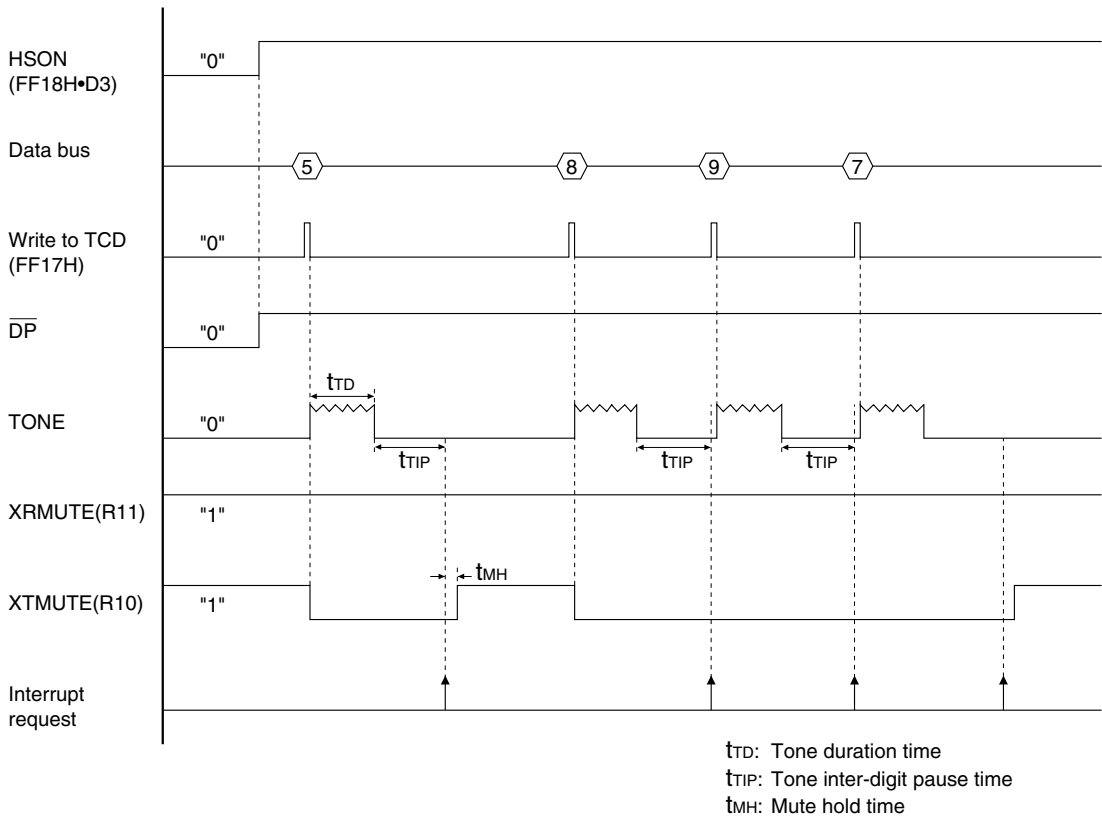

Fig. 4.14.4.2 Tone output timing chart

By writing data to the TCD register, the TONE terminal outputs the specified tone signal. At the same time, the XTMUTE (R10) terminal goes Low level.

The minimum tone duration time (t_{TD}) is 94 msec and can be prolonged using the CTO register (FF16H•D3). When the CTO register is set to "1" before writing data to the TCD register, the tone output continues until "0" is written to the CTO register. However the tone signal will be output for 94 msec even if the CTO register is set to "0" before 94 msec duration time has passed. The tone duration time when the CTO register is set to "0" is 94 msec.

When the tone signal has been output completely, the TONE terminal returns to Low level, then a 94 msec of inter-digit pause will be inserted.

An interrupt occurs when the inter-digit pause time has passed. It allows transmission of the next tone.

The XTMUTE (R10) terminal keeps on Low level for 4 msec of mute hold time (t_{MH}) after the inter-digit pause is released. If the next tone output does not start in this period, the XTMUTE (R10) terminal returns to High level. When the next tone output starts in the mute hold period, the XTMUTE (R10) terminal will stay in Low level.

Note that the CTMUT register (FF18H•D0) and CRMUT register (FF18H•D1) must be set to "1" when the above mute function (XTMUTE and XRMUTE control) is used.

The following summarizes a dialing procedure in the tone mode:

1. Write "1" to the HSON register.
 2. Write "1" to the CTO register. (note)
 3. Write the dial tone data to the TCD register. (tone output is started)
 4. Count the tone duration time and then write "0" to the CTO register. (note)
 5. Reset the interrupt factor flag after an interrupt has occurred.
 6. Repeat steps 2 to 5 for the number of dial digits.
- :
- Communication
- :
7. Write "0" to the HSON register after communication is finished.

Note: The CTO register in 2 and 4 should be controlled if more than 94 msec tone duration time is required. It is not necessary when outputting a tone for 94 msec.

4.14.5 Pulse mode (DP)

The pulse mode outputs dial pulses. By specifying a dial number using software, the DP generator generates the pulse pattern and outputs it from the \overline{DP} terminal.

At initial reset, the dialer is set in tone mode. To change the mode to the pulse mode, write "1" to the TPS register (FF10H•D3).

Figure 4.14.5.1 shows the block diagram of the DP generator.

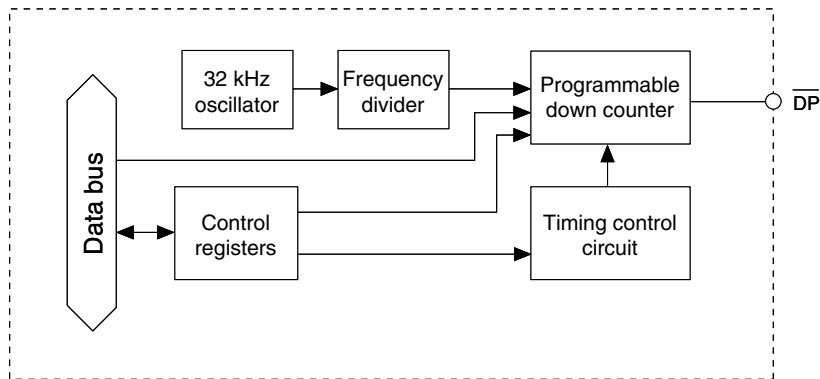

Fig. 4.14.5.1 DP generator block diagram

The DP generator uses the OSC1 (32 kHz) clock for generating dial pulses. In this mode it is not necessary to control the OSC3 oscillation circuit as in the tone mode.

In the pulse mode, the specified dial number (1 to 9) represents the number of pulses ("0" represents 10 pulses). The DP generator has a built-in programmable down counter in which a dial number can be preset. It produces dial pulses by means of a count down until it is equal to "0".

The pulse specification can be set by software and the timing control circuit controls the down counter according to the settings.

The software can set a pulse rate, make ratio and an inter-digit pause time.

The pulse rate is a number of output pulses per second, and can be selected to be either 10 pps (DRS = "0") or 20 pps (DRS = "1") using the DRS register. At initial reset, it is set to 10 pps (DRS = "0").

The make ratio (M:B) is the ratio of the make period (High) to the break period (Low). It can be selected to either 40:60 (MB = "0") or 33.3:66.6 (MB = "1") using the MB register (FF10H•D1). At initial reset, it is set to 40:60 (MB = "0").

The inter-digit pause time is the interval between digits of a dial number. It can be selected from among 15 types within 94 msec to 1,406 msec using the IDP3–IDP0 register (FF15H) as shown in Table 4.14.5.1.

Table 4.14.5.1 Selection of inter-digit pause time

IDP				Inter-digit pause time (msec)	IDP				Inter-digit pause time (msec)
D3	D2	D1	D0		D3	D2	D1	D0	
0	0	0	0	Unavailable *	1	0	0	0	750
0	0	0	1	94	1	0	0	1	844
0	0	1	0	188	1	0	1	0	938
0	0	1	1	281	1	0	1	1	1031
0	1	0	0	375	1	1	0	0	1125
0	1	0	1	469	1	1	0	1	1219
0	1	1	0	563	1	1	1	0	1313
0	1	1	1	656	1	1	1	1	1406

* Do not write "0" (0000B) to the IDP register because it may cause a malfunction.

At initial reset, the inter-digit pause time is set to 750 msec (IDP = "1000B").

The following summarizes initial setting items that must be set before outputting dial pulses:

1. Set to pulse mode (TPS = "1").
2. Select a pulse rate (10 pps or 20 pps) using DRS.
3. Select a make ratio (40:60 or 33.3:66.6) using MB.
4. Select an inter-digit pause time (94 msec to 1,406 msec) using IDP.

The following explains how to output dial pulses and the circuit operation.

First, write "1" to the HSON register (FF18H•D3) so the dialer is in off-hook status. As a result, the \overline{DP} terminal goes High (VDD) level.

Next, write a digit of the dial number to be transmitted to the TCD3–TCD0 register (FF17H). Table 4.14.5.2 shows the relationship of write data and pulse counts.

Table 4.14.5.2 Pulse count selection

TCD code				Pulse count	TCD code				Pulse count
D3	D2	D1	D0		D3	D2	D1	D0	
0	0	0	0	Unavailable *	1	0	0	0	8
0	0	0	1	1	1	0	0	1	9
0	0	1	0	2	1	0	1	0	10
0	0	1	1	3	1	0	1	1	11
0	1	0	0	4	1	1	0	0	12
0	1	0	1	5	1	1	0	1	13
0	1	1	0	6	1	1	1	0	14
0	1	1	1	7	1	1	1	1	15

* Do not write "0" (0000B) to the TCD register because it may cause a malfunction.

For a dial number between "1" to "9", the number is used for the pulse count as is. Dial number "0" represents 10 pulses, so write "10" (1010B) to the TCD register.

Writing data to the TCD register triggers the start of the pulse output.

Figure 4.14.5.2 shows a pulse output timing chart.

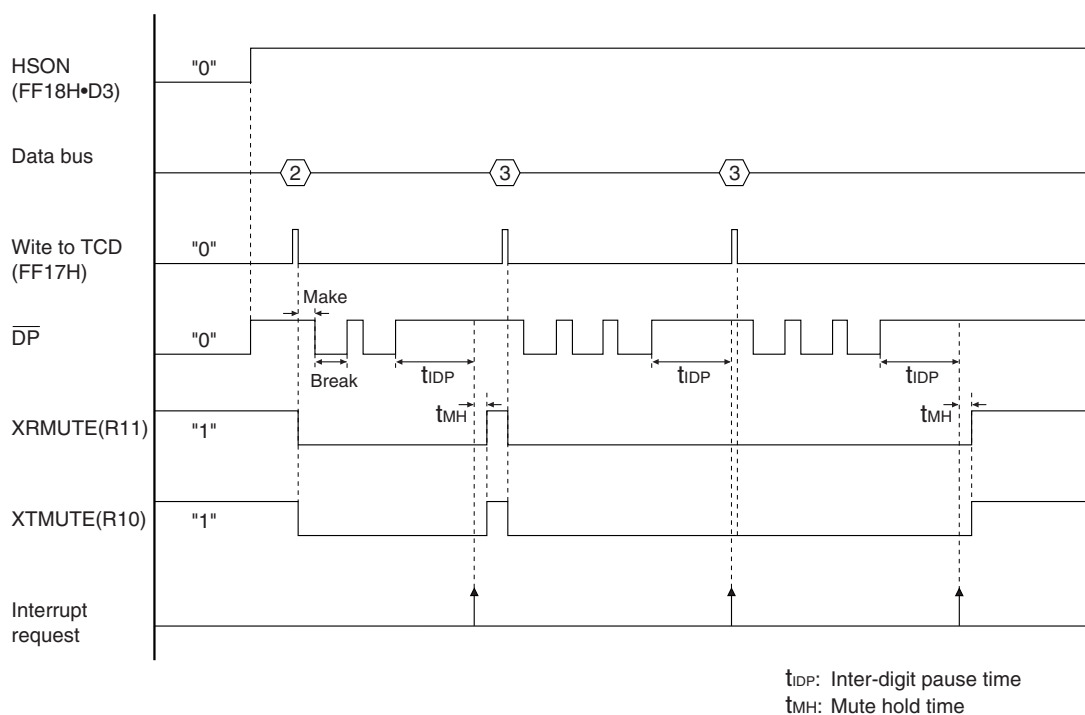

Fig. 4.14.5.2 Pulse output timing chart

When data is written to the TCD register, the specified number of pulses are output from the \overline{DP} terminal. At the same time, XRMUTE (R11) and XTMUTE (R10) terminals go Low level.

When the pulses have been output completely, the \overline{DP} terminal returns to High level, then the specified inter-digit pause will be inserted.

An interrupt occurs when the inter-digit pause time has passed. It allows transmission of the next dial pulses.

The XRMUTE (R11) and XTMUTE (R10) terminals keep on Low level for 4 msec of mute hold time (t_{MH}) after the inter-digit pause is released. If the next pulse output does not start in this period, the XRMUTE (R11) and XTMUTE (R10) terminals return to High level. When the next pulse output starts in the mute hold period, the XRMUTE (R11) and XTMUTE (R10) terminals will stay in Low level.

Note that the CTMUT register (FF18H•D0) and CRMUT register (FF18H•D1) must be set to "1" when the above mute function (XTMUTE and XRMUTE control) is used.

The following summarizes a dialing procedure in the pulse mode:

1. Write "1" to the HSON register.
 2. Write a dial number to the TCD register. (pulse output starts)
 3. Reset the interrupt factor flag after an interrupt has occurred.
 4. Repeat steps 2 to 3 for the number of dial digits.
- :
- Communication
- :
5. Write "0" to the HSON register after communication is finished.

4.14.6 Pause

This dialer allows insertion of a pause within 1 to 15 seconds between each two digits of tone signals or pulses. The pause time should be set to the PTS3–PTS0 register (FF11H) as shown in Table 4.14.6.1 before dialing.

Table 4.14.6.1 Pause time selection

PTS				Pause time (sec)	PTS				Pause time (sec)
D3	D2	D1	D0		D3	D2	D1	D0	
0	0	0	0	Unavailable *	1	0	0	0	8
0	0	0	1	1	1	0	0	1	9
0	0	1	0	2	1	0	1	0	10
0	0	1	1	3	1	0	1	1	11
0	1	0	0	4	1	1	0	0	12
0	1	0	1	5	1	1	0	1	13
0	1	1	0	6	1	1	1	0	14
0	1	1	1	7	1	1	1	1	15

* Do not write "0" (0000B) to the PTS register because it may cause a malfunction.

At initial reset, the pause time is set to 4 seconds.

Writing data to the PTS register just defines the pause time. The actual pause operation will be activated when the PAUSE bit (FF14H•D1) is set to "1".

Figure 4.14.6.1 shows the timing chart of the pause function.

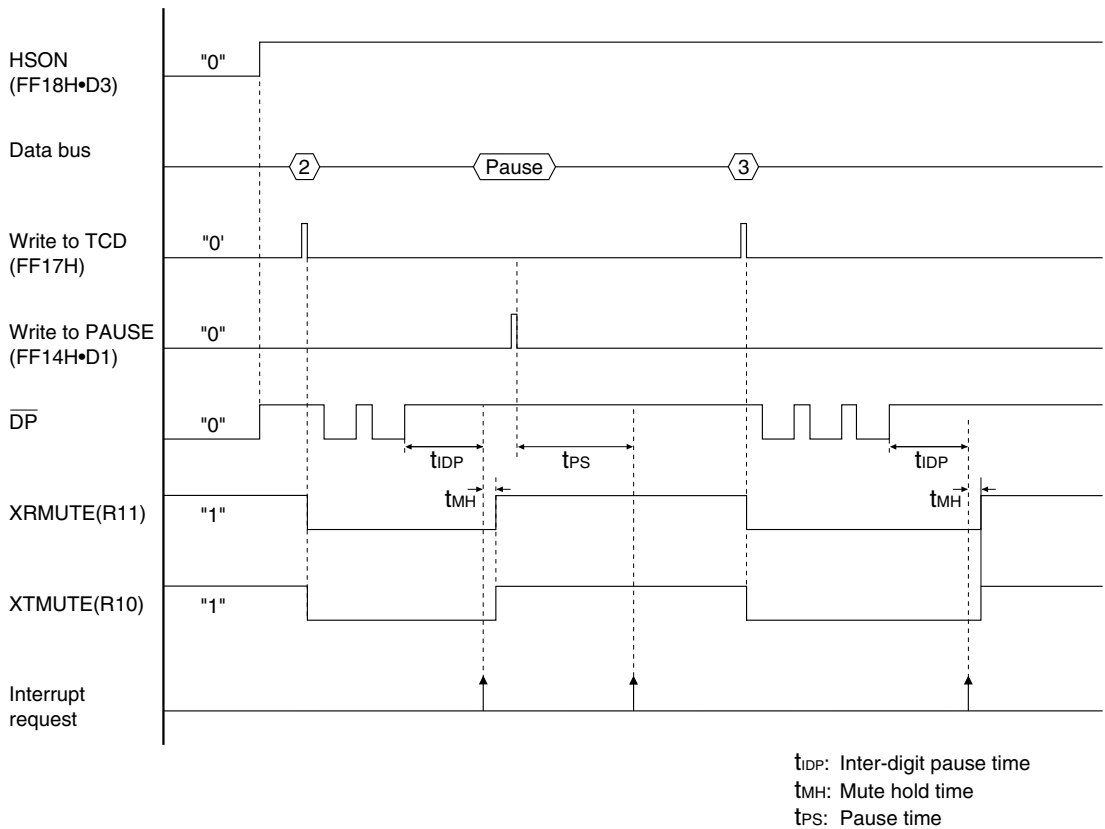

Fig. 4.14.6.1(a) Pause execution timing chart in pulse mode

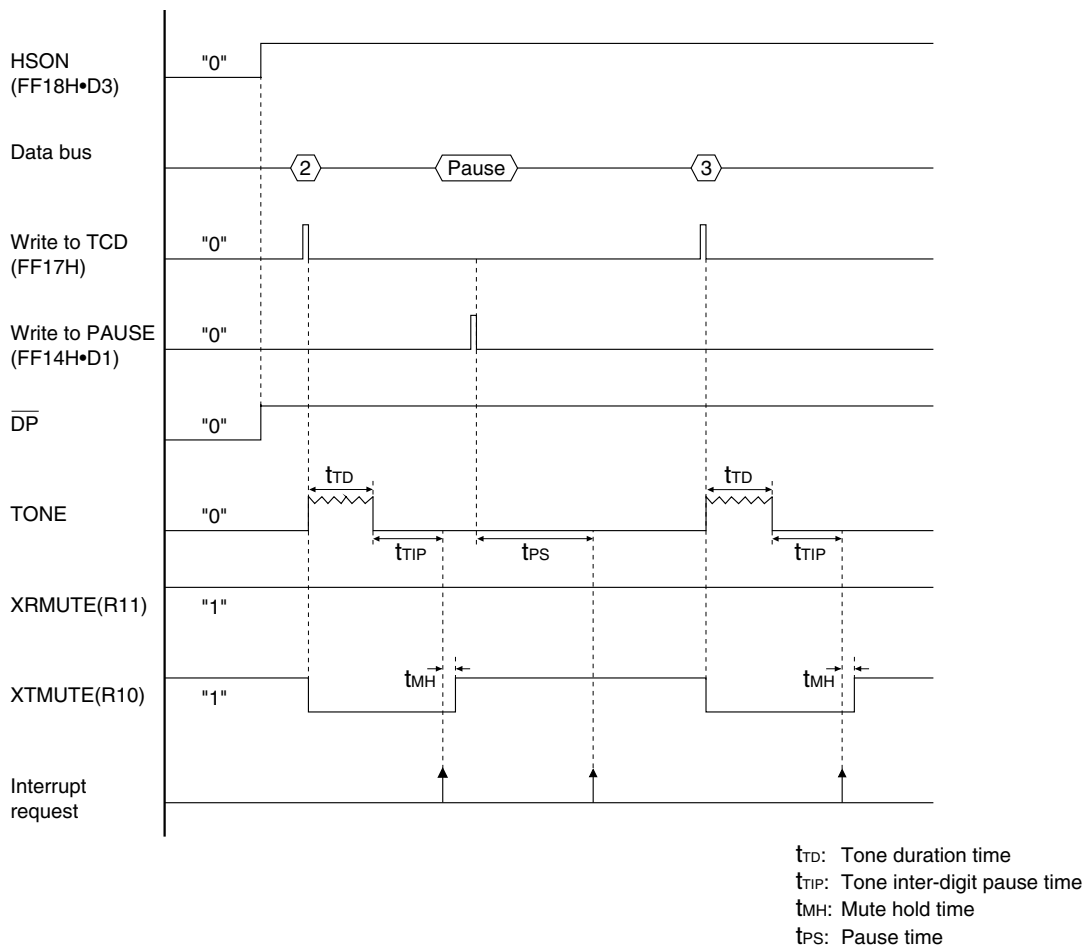

Fig. 4.14.6.1(b) Pause execution timing chart in tone mode

PAUSE is a write-only bit and is used as the trigger for a pause insertion. When the pause time that is set to the PTS register has passed from the writing of the PAUSE bit, an interrupt occurs. At the same time the PAUSE bit is automatically cleared to "0" by the interrupt. Thus the pause function requires start control only.

The pause function uses the same interrupt system as the dialing completion. Therefore, the interrupt factor flag ID must be reset before executing the pause function.

4.14.7 Flash

The flash function pulls down the \overline{DP} terminal to Low level for a predetermined period of time to temporarily restore the telephone to on-hook status. The flash time should be set to the FTS3–FTS0 register (FF12H). Table 4.14.7.1 lists the available flash time.

Table 4.14.7.1 Flash time selection

FTS				Flash time (msec)	FTS				Flash time (msec)
D3	D2	D1	D0		D3	D2	D1	D0	
0	0	0	0	Unavailable *	1	0	0	0	750
0	0	0	1	94	1	0	0	1	844
0	0	1	0	188	1	0	1	0	938
0	0	1	1	281	1	0	1	1	1031
0	1	0	0	375	1	1	0	0	1125
0	1	0	1	469	1	1	0	1	1219
0	1	1	0	563	1	1	1	0	1313
0	1	1	1	656	1	1	1	1	1406

* Do not write "0" (0000B) to the FTS register because it may cause a malfunction.

At initial reset, the flash time is set to 563 msec.

Writing data to the FTS register just defines the flash time. The actual flash operation will be activated when the FLASH bit (FF14H•D0) is set to "1".

Figure 4.14.7.1 shows a timing chart of the flash function.

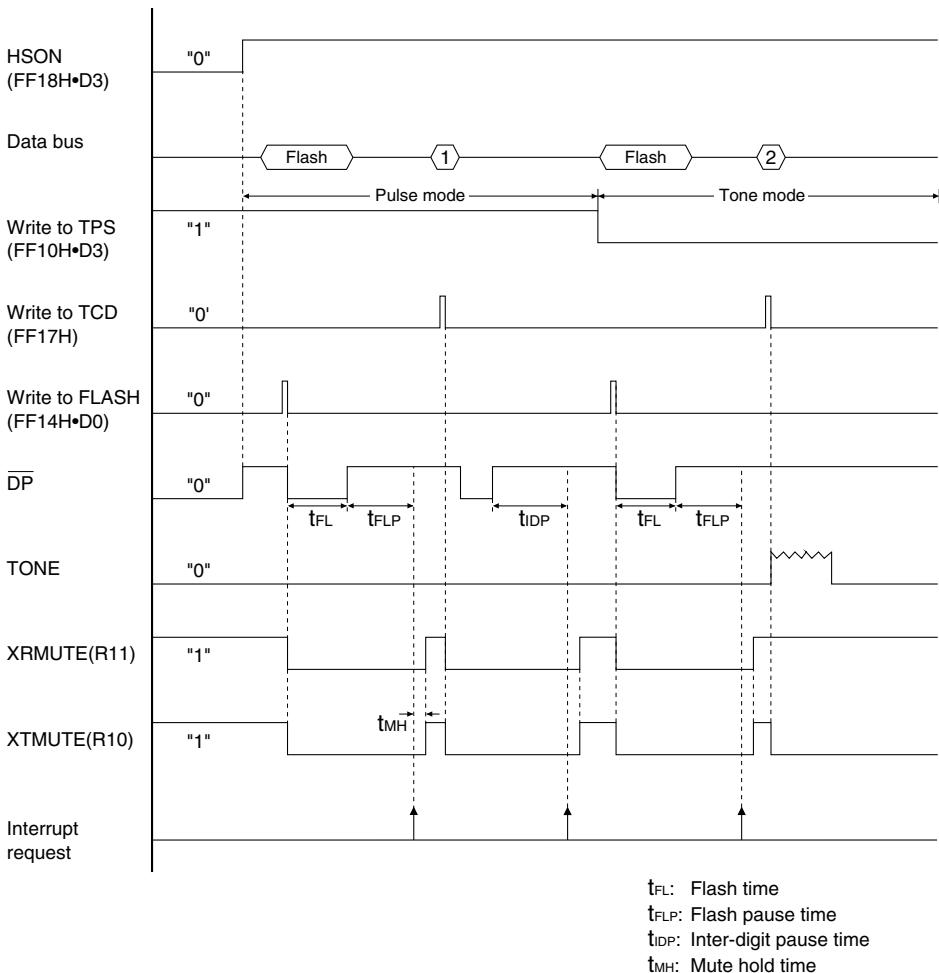

Fig. 4.14.7.1 Flash execution timing chart

FLASH is a write-only bit and is used as the trigger for a flash operation. When the FLASH bit is set to "1", the DP terminal goes Low level until the flash time set by the FTS register has passed, then the DP terminal returns to High level. After that 938 msec of the flash pause time is taken and an interrupt occurs. At the same time the FLASH bit is automatically cleared to "0" by the interrupt. Thus the flash function requires start control only.

The flash function uses the same interrupt system as the dialing completion. Therefore, the interrupt factor flag ID must be reset before executing the flash function.

4.14.8 Hold-line

The hold-line function can assert the XTMUTE signal while holding the current communication line open. This function can be controlled using the HOLD register. When "1" is written to the HOLD register, the communication line is held open and the XTMUTE signal goes Low level. When "0" is written, the XTMUTE signal returns to High level.

The R12 terminal can be used to output the HDO signal that indicates hold status. To use the HDO signal, set the R12 port for the HDO output by writing "1" to the CHDO register (FF13H•D2). The R12 terminal will output the HDO signal by controlling the HOLD register. In this case, the output port data register R12 must be fixed at "1" and the high impedance control register at "0". Note that the HDO signal will be fixed at Low level if the R12 register is set to "0".

Figure 4.14.8.1 shows a timing chart of the hold-line function.

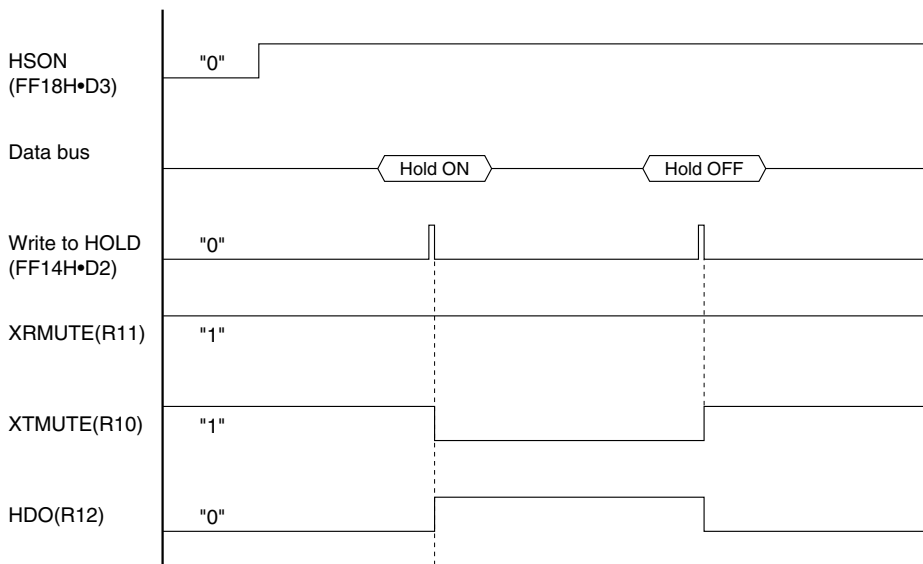

Fig. 4.14.8.1 Hold-line execution timing chart

4.14.9 Interrupt

The dialer has three types of interrupt generation functions.

(1) Dialing interrupt

Tone mode

In the tone mode, 94 msec of an inter-digit pause is made after a tone signal (min. 94 msec, can be prolonged by the CTO register) is output completely. A dialing interrupt occurs immediately following the inter-digit pause. See the timing chart in Figure 4.14.4.2.

Pulse mode

In the pulse mode, the inter-digit pause set by the IDP register is made after a dial pulse digit is output completely. A dialing interrupt occurs immediately following the inter-digit pause. See the timing chart in Figure 4.14.5.2.

(2) Pause interrupt

When the pause function is executed, an interrupt occurs when the pause time (1 to 15 sec) set by the PTS register has passed after writing "1" to the PAUSE bit. See the timing chart in Figure 4.14.6.1.

(3) Flash interrupt

When the flash function is executed, 938 msec of a flash pause is made when the flash time (94 to 1,406 msec) set by the FTS register has passed after writing "1" to the FLASH bit. A flash interrupt occurs immediately following the flash pause. See the timing chart in Figure 4.14.7.1.

The interrupt factor flag ID (FFF9H•D0) is set to "1" when an interrupt occurs. The interrupt request will be delivered to the CPU only when the interrupt mask register EID (FFE9H•D0) is set to "1".

If the EID register is set to "0", the interrupt request will be masked. However, the ID flag will be set at the above timing regardless of the EID register setting. So operation status can also be checked by reading the ID flag.

The ID flag is reset by writing "1". It must be reset for the next interrupt after an interrupt has occurred.

4.14.10 I/O memory of telephone function

Table 4.14.10.1 shows the I/O address and the control bits for the telephone function.

Table 4.14.10.1 Control bits of telephone function

Address	Register				Name	Init *1	1	0	Comment
	D3	D2	D1	D0					
FF00H	CLKCHG	OSCC	0	Dummy	CLKCHG	0	OSC3	OSC1	CPU clock switch
					OSCC	0	On	Off	OSC3 oscillation On/Off
	R/W		R	R/W	0 *3	- *2			Unused
FF10H	TPS	0	MB	DRS	TPS	0	Pulse	Tone	Tone / pulse mode selection
					0 *3	- *2			Unused
	R/W	R	R/W		MB	0	33.3:66.6	40:60	Make : Break ratio selection
FF11H	PTS3	PTS2	PTS1	PTS0	PTS3	0			Pause time selection (initial value: 4 sec) [PTS3-0] 0 1 2 3 4 5 6 7 Time(sec) × 1 2 3 4 5 6 7 [PTS3-0] 8 9 10 11 12 13 14 15 Time(sec) 8 9 10 11 12 13 14 15
	R/W				PTS2	1			
					PTS1	0			
				PTS0	0				
FF12H	FTS3	FTS2	FTS1	FTS0	FTS3	0			Flash time selection (initial value: 563 ms) [FTS3-0] 0 1 2 3 4 5 6 7 Time(ms) × 94 188 281 375 469 563 656 [FTS3-0] 8 9 10 11 12 13 14 15 Time(ms) 750 844 938 1031 1125 1219 1313 1406
	R/W				FTS2	1			
					FTS1	1			
				FTS0	0				
FF13H	CHFO	CHDO	CRMO	CTMO	CHFO	0	HFO	DC	R13 output selection (R13 should be fixed at "1".)
					CHDO	0	HDO	DC	R12 output selection (R12 should be fixed at "1".)
	R/W				CRMO	0	XRMUTE	DC	R11 output selection (R11 should be fixed at "1".)
FF14H	HF	HOLD	PAUSE	FLASH	CTMO	0	XTMUTE	DC	R10 output selection (R10 should be fixed at "1".)
					HF	0	Yes	No	Hand free
	R/W		W		HOLD	0	On	Off	Hold-line function
FF15H	IDP3	IDP2	IDP1	IDP0	PAUSE*3	0	Yes	No	Pause function
	R/W				FLASH*3	0	Yes	No	Flash function
					IDP3	1			Inter-digit pause selection for dial pulse (initial value: 750 ms) [IDP3-0] 0 1 2 3 4 5 6 7 Time(ms) × 94 188 281 375 469 563 656 [IDP3-0] 8 9 10 11 12 13 14 15 Time(ms) 750 844 938 1031 1125 1219 1313 1406
				IDP2	0				
				IDP1	0				
				IDP0	0				
FF16H	CTO	0	SINR	SINC	CTO	0	On	Off	Continuous tone output On/Off
					0 *3	- *2			Unused
	R/W	R	R/W		SINR	1	Enable	Disable	DTMF row frequency output enable
FF17H	TCD3	TCD2	TCD1	TCD0	SINC	1	Enable	Disable	DTMF column frequency output enable
	R/W				TCD3	0			Telephone code for dialing [TCD3-0] 0 1 2 3 4 5 6 7 DTMF (R1C4)(R1C1)(R1C2)(R1C3)(R2C1)(R2C2)(R2C3)(R3C1) DP × 1 2 3 4 5 6 7 [TCD3-0] 8 9 10 11 12 13 14 15 DTMF (R3C2)(R3C3)(R4C2)(R4C3)(R4C1)(R2C4)(R4C4)(R3C4) DP 8 9 10 11 12 13 14 15
					TCD2	0			
				TCD1	0				
				TCD0	0				
FF18H	HSON	0	CRMUT	CTMUT	HSON	0	Off	On	Hook switch On/Off
					0 *3	- *2			Unused
	R/W	R	R/W		CRMUT	1	Mute	0	Receive mute control
FF32H	R13HIZ	R12HIZ	R11HIZ	R10HIZ	CTMUT	1	Mute	0	Transmit mute control
	R/W				R13HIZ	0	Hi-Z	Output	R13 (CHFO=0)/HFO (CHFO=1) Hi-z control
					R12HIZ	0	Hi-Z	Output	R12 (CHDO=0)/HDO (CHDO=1) Hi-z control
FF33H	R13 (HFO)	R12 (HDO)	R11 (XRMUTE)	R10 (XTMUTE)	R11HIZ	0	Hi-Z	Output	R11 (CRMO=0)/XRMUTE (CRMO=1) Hi-z control
	R/W				R10HIZ	0	Hi-Z	Output	R10 (CTMO=0)/XTMUTE (CTMO=1) Hi-z control
					R13	1	High	Low	R13 output port data (CHFO=0) Fix at "1" when HFO is used.
FFE9H	0	0	0	EID	R12	1	High	Low	R12 output port data (CHDO=0) Fix at "1" when HDO is used.
	R			R/W	R11	1	High	Low	R11 output port data (CRMO=0) Fix at "1" when XRMUTE is used.
					R10	1	High	Low	R10 output port data (CTMO=0) Fix at "1" when XTMUTE is used.
FFF9H	0	0	0	ID	0 *3	- *2	(R)	(R)	Unused
	R			R/W	0 *3	- *2	Yes	No	Unused
					0 *3	- *2	(W)	(W)	Unused
				ID	0	Reset	Invalid		Interrupt factor flag (Dialer)

*1 Initial value at initial reset

*3 Constantly "0" when being read

*2 Not set in the circuit

R10HIZ–R13HIZ: R1 port high impedance control register (FF32H)

Controls high impedance output of the output port.

When "1" is written: High impedance

When "0" is written: Data output

Reading: Valid

When using the XTMUTE, XRMUTE, HDO and HFO outputs, fix these registers at "0". R10HIZ, R11HIZ, R12HIZ and R13HIZ correspond to the XTMUTE, XRMUTE, HDO and HFO outputs, respectively.

At initial reset, these registers are set to "0".

R10–R13: R1 output port data register (FF33H)

Set the output data for the output ports.

When "1" is written: High level output

When "0" is written: Low level output

Reading: Valid

When using the XTMUTE, XRMUTE, HDO and HFO outputs, fix these registers at "1". R10, R11, R12 and R13 correspond to the XTMUTE, XRMUTE, HDO and HFO outputs, respectively.

At initial reset, these registers are all set to "1".

CTMO: R10 output selection register (FF13H•D0)

Selects the R10 terminal function.

When "1" is written: XTMUTE output

When "0" is written: General-purpose DC output

Reading: Valid

When using the R10 terminal for the XTMUTE output, write "1" to this register. Furthermore, fix the R10 register at "1" and the R10HIZ register at "0".

The XTMUTE output is controlled by the CTMUT register (FF18H•D0).

At initial reset, this register is set to "0".

CRMO: R11 output selection register (FF13H•D1)

Selects the R11 terminal function.

When "1" is written: XRMUTE output

When "0" is written: General-purpose DC output

Reading: Valid

When using the R11 terminal for the XRMUTE output, write "1" to this register. Furthermore, fix the R11 register at "1" and the R11HIZ register at "0".

The XRMUTE output is controlled by the CRMUT register (FF18H•D1).

At initial reset, this register is set to "0".

CHDO: R12 output selection register (FF13H•D2)

Selects the R12 terminal function.

When "1" is written: HDO output

When "0" is written: General-purpose DC output

Reading: Valid

When using the R12 terminal for the HDO output, write "1" to this register. Furthermore, fix the R12 register at "1" and the R12HIZ register at "0".

The HDO output is controlled by the HOLD register (FF14H•D2).

At initial reset, this register is set to "0".

CHFO: R13 output selection register (FF13H•D3)

Selects the R13 terminal function.

- When "1" is written: HFO output
- When "0" is written: General-purpose DC output
- Reading: Valid

When using the R13 terminal for the HFO output, write "1" to this register. Furthermore, fix the R13 register at "1" and the R13HIZ register at "0".

The HFO output is controlled by the HF register (FF14H•D3).

At initial reset, this register is set to "0".

OSCC: OSC3 oscillation control (FF00H•D2)

Controls the OSC3 oscillation.

- When "1" is written: OSC3 oscillation ON
- When "0" is written: OSC3 oscillation OFF
- Reading: Valid

When it is necessary to activate the DTMF generator or to operate the CPU at high speed, set OSCC to "1". At other times, set it to "0" to reduce current consumption. At initial reset, this register is set to "0".

TPS: Tone/Pulse mode selection (FF10H•D3)

Selects a dialing mode.

- When "1" is written: Pulse mode
- When "0" is written: Tone mode
- Reading: Valid

When "1" is written to the TPS register, pulse mode (outputs dial pulses) is selected. When "0" is written, tone mode (outputs tone signals) is selected.

At initial reset, this register is set to "0".

MB: Make/Break ratio selection (FF10H•D1)

Selects a make ratio for pulse mode.

- When "1" is written: 33.3 : 66.6
- When "0" is written: 40.0 : 60.0
- Reading: Valid

The make ratio (make : break) of the dialing pulses that are generated from the DP generator is set. When "1" is written to the MB register, 33.3 : 66.6 is set. When "0" is written, 40.0 : 60.0 is set. The DP generator produces the dialing pulses as "Make" (High) period is before "Break" (Low) period.

This selection is valid only for pulse mode.

At initial reset, this register is set to "0".

DRS: Dialing pulse rate selection (FF10H•D0)

Selects a dialing pulse rate for pulse mode.

- When "1" is written: 20 pps (pulses per second)
- When "0" is written: 10 pps (pulses per second)
- Reading: Valid

The pulse rate (number of pulses per second) for the dialing pulses that are generated from the DP generator is set. When "1" is written to the DRS register, 20 pps is set. When "0" is written, 10 pps is set.

This selection is valid only for pulse mode.

At initial reset, this register is set to "0".

PTS0–PTS3: Pause time selection (FF11H)

Selects a pause time from among the 15 types shown in Table 4.14.10.2.

Table 4.14.10.2 Selection of pause times

PTS				Pause time (sec)	PTS				Pause time (sec)
D3	D2	D1	D0		D3	D2	D1	D0	
0	0	0	0	Unavailable *	1	0	0	0	8
0	0	0	1	1	1	0	0	1	9
0	0	1	0	2	1	0	1	0	10
0	0	1	1	3	1	0	1	1	11
0	1	0	0	4	1	1	0	0	12
0	1	0	1	5	1	1	0	1	13
0	1	1	0	6	1	1	1	0	14
0	1	1	1	7	1	1	1	1	15

* Do not write "0" (0000B) to the PTS register because it may cause a malfunction.

The specified pause time will be inserted when "1" is written to the PAUSE bit (FF14H•D1). At initial reset, this register is set to "0100B" (4 seconds).

FTS0–FTS3: Flash time selection (FF12H)

Selects a flash time from among the 15 types shown in Table 4.14.10.3.

Table 4.14.10.3 Selection of flash times

FTS				Flash time (msec)	FTS				Flash time (msec)
D3	D2	D1	D0		D3	D2	D1	D0	
0	0	0	0	Unavailable *	1	0	0	0	750
0	0	0	1	94	1	0	0	1	844
0	0	1	0	188	1	0	1	0	938
0	0	1	1	281	1	0	1	1	1031
0	1	0	0	375	1	1	0	0	1125
0	1	0	1	469	1	1	0	1	1219
0	1	1	0	563	1	1	1	0	1313
0	1	1	1	656	1	1	1	1	1406

* Do not write "0" (0000B) to the FTS register because it may cause a malfunction.

The specified flash time will be inserted when "1" is written to the FLASH bit (FF14H•D0). At initial reset, this register is set to "0110B" (563 msec).

HOLD: Hold-line function (FF14H•D2)

Controls the hold-line function and HDO signal output.

- When "1" is written: ON (High level output on R12 terminal)
- When "0" is written: OFF (Low level output on R12 terminal)
- Reading: Valid

This register controls the HDO signal output to the R12 terminal when the HDO function has been selected. The HDO output function is set by writing "1" to the CHDO register (FF13H•D2). In this case, the R12 register must be fixed at "1" and the R12HIZ register at "0".

When "1" is written to the HOLD register, the XTMUTE (R10) terminal goes Low (Vss) level and the HDO (R12) terminal goes High (VDD) level.

When "0" is written, the XTMUTE (R10) terminal goes High (VDD) level and the HDO (R12) terminal goes Low (Vss) level.

At initial reset, this register is set to "0".

PAUSE: Pause function (FF14H•D1)

Executes the pause function.

- When "1" is written: Execute pause function
- When "0" is written: Cancel pause function
- Reading: Always "0"

Writing "1" to PAUSE executes the pause function. The pause time set by the PTS register is inserted to the \overline{DP} output signal. An interrupt occurs when the pause is released and the PAUSE bit is automatically cleared to "0".

This bit is write-only, and so is always "0" at reading.

FLASH: Flash function (FF14H•D0)

Executes the flash function.

- When "1" is written: Execute flash function
- When "0" is written: Cancel flash function
- Reading: Always "0"

Writing "1" to FLASH executes the flash function. The \overline{DP} , XRMUTE (R11) and XTMUTE (R10) terminals go Low (Vss) level during the flash period set by the FTS register and then an interrupt occurs. At the same time the FLASH bit is automatically cleared to "0" by the interrupt.

This bit is write-only, and so is always "0" at reading.

HF: Handfree (FF14H•D3)

Controls the handfree function and HFO signal output.

- When "1" is written: ON (High level output on R13 terminal)
- When "0" is written: OFF (Low level output on R13 terminal)
- Reading: Valid

This register controls the HFO signal output to the R13 terminal when the HFO function has been selected. The HFO output function is set by writing "1" to the CHFO register (FF13H•D3). In this case, the R13 register must be fixed at "1" and the R13HIZ register at "0".

When "1" is written to the HF register, the HFO (R13) terminal goes High (VDD) level.

When "0" is written, the HFO (R13) terminal goes Low (Vss) level.

At initial reset, this register is set to "0".

IDP0-IDP3: Inter-digit pause time selection (FF15H)

Select an inter-digit pause time for the pulse mode from among the 15 types shown in Table 4.14.10.4.

Table 4.14.10.4 Selection of inter-digit pause times

IDP				Inter-digit pause time (msec)	IDP				Inter-digit pause time (msec)
D3	D2	D1	D0		D3	D2	D1	D0	
0	0	0	0	Unavailable *	1	0	0	0	750
0	0	0	1	94	1	0	0	1	844
0	0	1	0	188	1	0	1	0	938
0	0	1	1	281	1	0	1	1	1031
0	1	0	0	375	1	1	0	0	1125
0	1	0	1	469	1	1	0	1	1219
0	1	1	0	563	1	1	1	0	1313
0	1	1	1	656	1	1	1	1	1406

* Do not write "0" (0000B) to the IDP register because it may cause a malfunction.

The specified inter-digit pause time will be inserted after each dialing pulse digit. This selection is valid only for pulse mode.

At initial reset, this register is set to "1000B" (750 msec).

SINR: DTMF row frequencies output enable (FF16H•D1)

Enables or disables the DTMF row frequency output.

- When "1" is written: Enabled
- When "0" is written: Disabled
- Reading: Valid

This register is used to set the tone output mode with the SINC register. Write "1" to this register when performing dual-tone output or single-tone ROW frequency output. At initial reset, this register is set to "1".

SINC: DTMF column frequencies output enable (FF16H•D0)

Enables or disables the DTMF column frequency output.

- When "1" is written: Enabled
- When "0" is written: Disabled
- Reading: Valid

This register is used to set the tone output mode with the SINR register. Write "1" to this register when performing dual-tone output or single-tone COL frequency output. At initial reset, this register is set to "1".

Table 4.14.10.5 lists the tone output selection using the SINR and SINC registers.

Table 4.14.10.5 Selection of tone output

Control register		Tone output
SINR	SINC	
0	0	DC level: 1/2 (VDD–VSS)
0	1	COL frequency
1	0	ROW frequency
1	1	Dual tone output

Tables 4.14.10.6(a) and (b) list the frequencies set by the TCD register (FF17H) when single tone output is selected.

Table 4.14.10.6(a) Single-tone COL frequencies (SINR = "0", SINC = "1")

TCD code				COL frequency (Hz)	TCD code				COL frequency (Hz)
D3	D2	D1	D0		D3	D2	D1	D0	
0	0	0	0	COL4: 1645.01	1	0	0	0	COL2: 1331.68
0	0	0	1	COL1: 1215.88	1	0	0	1	COL3: 1471.85
0	0	1	0	COL2: 1331.68	1	0	1	0	COL2: 1331.68
0	0	1	1	COL3: 1471.85	1	0	1	1	COL3: 1471.85
0	1	0	0	COL1: 1215.88	1	1	0	0	COL1: 1215.88
0	1	0	1	COL2: 1331.68	1	1	0	1	COL4: 1645.01
0	1	1	0	COL3: 1471.85	1	1	1	0	COL4: 1645.01
0	1	1	1	COL1: 1215.88	1	1	1	1	COL4: 1645.01

Table 4.14.10.6(b) Single-tone ROW frequencies (SINR = "1", SINC = "0")

TCD code				ROW frequency (Hz)	TCD code				ROW frequency (Hz)
D3	D2	D1	D0		D3	D2	D1	D0	
0	0	0	0	ROW1: 701.32	1	0	0	0	ROW3: 857.17
0	0	0	1	ROW1: 701.32	1	0	0	1	ROW3: 857.17
0	0	1	0	ROW1: 701.32	1	0	1	0	ROW4: 935.10
0	0	1	1	ROW1: 701.32	1	0	1	1	ROW4: 935.10
0	1	0	0	ROW2: 771.45	1	1	0	0	ROW4: 935.10
0	1	0	1	ROW2: 771.45	1	1	0	1	ROW2: 771.45
0	1	1	0	ROW2: 771.45	1	1	1	0	ROW4: 935.10
0	1	1	1	ROW3: 857.17	1	1	1	1	ROW3: 857.17

TCD0–TCD3: Telephone code for dialing (FF17H)

By writing code to this register, the dialer starts outputting the corresponding dial pulses (in pulse mode) or tone signals (in tone mode). When the output is finished, an interrupt occurs.

At initial reset, this register is set to "0000B".

The following shows the register settings for each mode.

(1) Pulse mode

In this mode, write data for a dial number (1–9, 0) to this register.

Table 4.14.10.7 lists the relationship of writing codes and pulse counts.

Table 4.14.10.7 Relationship of code sand pulse counts

TCD code				Pulse count	TCD code				Pulse count
D3	D2	D1	D0		D3	D2	D1	D0	
0	0	0	0	Unavailable *	1	0	0	0	8
0	0	0	1	1	1	0	0	1	9
0	0	1	0	2	1	0	1	0	10
0	0	1	1	3	1	0	1	1	11
0	1	0	0	4	1	1	0	0	12
0	1	0	1	5	1	1	0	1	13
0	1	1	0	6	1	1	1	0	14
0	1	1	1	7	1	1	1	1	15

* Do not write "0" (0000B) to the TCD register because it may cause a malfunction.

For a dial number between "1" to "9", the number is used for the pulse count as is. Dial number "0" represents 10 pulses, so write "10" (1010B) to the TCD register.

(2) Tone mode

In this mode, write data for a push button (ROW, COL) to this register.

Table 4.14.10.8 lists the relationship of writing codes and tone frequencies.

Table 4.14.10.8 Relationship of codes and tone frequencies

TCD code				Tone frequency	Key symbol	TCD code				Tone frequency	Key symbol
D3	D2	D1	D0			D3	D2	D1	D0		
0	0	0	0	(ROW1, COL4)	"A"	1	0	0	0	(ROW3, COL2)	"8"
0	0	0	1	(ROW1, COL1)	"1"	1	0	0	1	(ROW3, COL3)	"9"
0	0	1	0	(ROW1, COL2)	"2"	1	0	1	0	(ROW4, COL2)	"0"
0	0	1	1	(ROW1, COL3)	"3"	1	0	1	1	(ROW4, COL3)	"#"
0	1	0	0	(ROW2, COL1)	"4"	1	1	0	0	(ROW4, COL1)	"*"
0	1	0	1	(ROW2, COL2)	"5"	1	1	0	1	(ROW2, COL4)	"B"
0	1	1	0	(ROW2, COL3)	"6"	1	1	1	0	(ROW4, COL4)	"D"
0	1	1	1	(ROW3, COL1)	"7"	1	1	1	1	(ROW3, COL4)	"C"

Writing data to this register triggers the start of the tone output. When single tone output is selected, either the ROW frequency or COL frequency corresponding to the written data is output as a tone signal. When dual tone output is selected, the specified ROW and COL frequencies are output after they are composed.

CRMUT: Receive mute control (FF18H•D1)

Controls the receive mute.

When "1" is written: Receive mute output

When "0" is written: Low level output on XRMUTE (R11) terminal

Reading: Valid

When "0" is written to the CRMUTE register, the XRMUTE (R11) terminal is pulled down to Low (Vss) level to mute the receive line.

When the CRMUTE register is set to "1", the XRMUTE (R11) terminal is controlled by the hardware and will be Low (Vss) level during a dialing pulse cycle or a flash cycle.

At initial reset, this register is set to "1".

CTMUT: Transmit mute control (FF18H•D0)

Controls the transmit mute.

When "1" is written: Transmit mute output

When "0" is written: Low level output on XTMUTE (R10) terminal

Reading: Valid

When "0" is written to the CTMUTE register, the XTMUTE (R10) terminal is pulled down to Low (V_{SS}) level to mute the transmit line.

When the CTMUTE register is set to "1", the XTMUTE (R10) terminal is controlled by the hardware and will be Low (V_{SS}) level during a dialing pulse cycle, flash cycle, dialing tone cycle or a hold-line cycle.

At initial reset, this register is set to "1".

HSON: Hook switch ON/OFF (FF18H•D0)

Controls the hook switch.

When "1" is written: Hook OFF

When "0" is written: Hook ON

Reading: Valid

When the HSON register is set to "1", the \overline{DP} terminal goes High (V_{DD}) level and the hook switch goes to off-hook status.

At initial reset, this register is set to "0".

CTO: Continuous output tone selection (FF16H•D3)

Selects the tone duration time to continuous output or not.

When "1" is written: Continuous

When "0" is written: 94 msec

Reading: Valid

This register is used to decide the tone duration time. The minimum value of tone duration time is 94 msec.

When the CTO register is set to "1", a tone signal will be output until the CTO register is changed to "0". If the period (CTO is changed from "1" to "0"), that is controlled by the CTO register, is less than 94 msec, the duration time will be prolonged to 94 msec.

When the CTO register is set to "0", a tone signal will be output with the minimum time (94 msec).

This setting is valid only for tone mode.

At initial reset, this register is set to "0".

EID: Interrupt mask register (FFE9H•D0)

Enables or disables the generation of an interrupt for the CPU.

When "1" is written: Enabled

When "0" is written: Disabled

Reading: Valid

EID is the interrupt mask register corresponding to the dialing interrupt factor. Interrupts set to "1" are enabled and interrupts set to "0" are disabled.

At initial reset, this register is set to "0".

ID: Interrupt factor flag (FFF9H•D0)

Indicates the dialing interrupt generation status.

When "1" is read: Interrupt has occurred

When "0" is read: Interrupt has not occurred

When "1" is written: Flag is reset

When "0" is written: Invalid

The interrupt factor flag ID is set to "1" when a dialing interrupt factor occurs (when a dialing output, pause or flash cycle is completed). After executing a dialing function (dialing number, pause, flash), this flag must be reset. Otherwise, the next dialing function can not be executed.

The interrupt factor flag is reset to "0" by writing "1".

After an interrupt occurs, the same interrupt will occur again if the interrupt enabled state (I flag = "1") is set or the RETI instruction is executed unless the interrupt factor flag is reset. Therefore, be sure to reset (write "1" to) the interrupt factor flag in the interrupt service routine before shifting to the interrupt enabled state.

At initial reset, this flag is set to "0".

4.14.11 Programming notes

- (1) It is necessary to turn the OSC3 oscillation on prior to a dialing operation in tone mode because the tone mode uses the OSC3 (3.58 MHz) clock. However it increases current consumption. Therefore, turn the OSC3 oscillation off after finishing the dialling operation in tone mode.
- (2) Do not write "0" (0000B) to the IDP, FTS, PTS or TCD (in pulse mode) registers because it may cause a malfunction.
- (3) The pause function control bit PAUSE (FF14H•D1) and the flash function control bit FLASH (FF14H•D0) are write-only, so software cannot control these functions (on address FF14H) using an ALU instruction (AND, OR ...). Furthermore, be aware that the pause function or the flash function is canceled when "0" is written to the PAUSE bit (FF14H•D1) or the FLASH bit (FF14H•D0).
- (4) After an interrupt occurs, the same interrupt will occur again if the interrupt enabled state (I flag = "1") is set or the RETI instruction is executed unless the interrupt factor flag is reset. Therefore, be sure to reset (write "1" to) the interrupt factor flag in the interrupt service routine before shifting to the interrupt enabled state.

4.15 FSK Demodulator

4.15.1 Configuration of FSK demodulator

The S1C63558 has a built-in FSK (Frequency Shift Keying) demodulator that interfaces to various calling information delivery services such as calling number delivery (compatible with ITU-T V.23/Bell 202). Figures 4.15.1.1 and 4.15.1.2 show the block diagram of the FSK demodulator and the configuration of FSK core block, respectively.

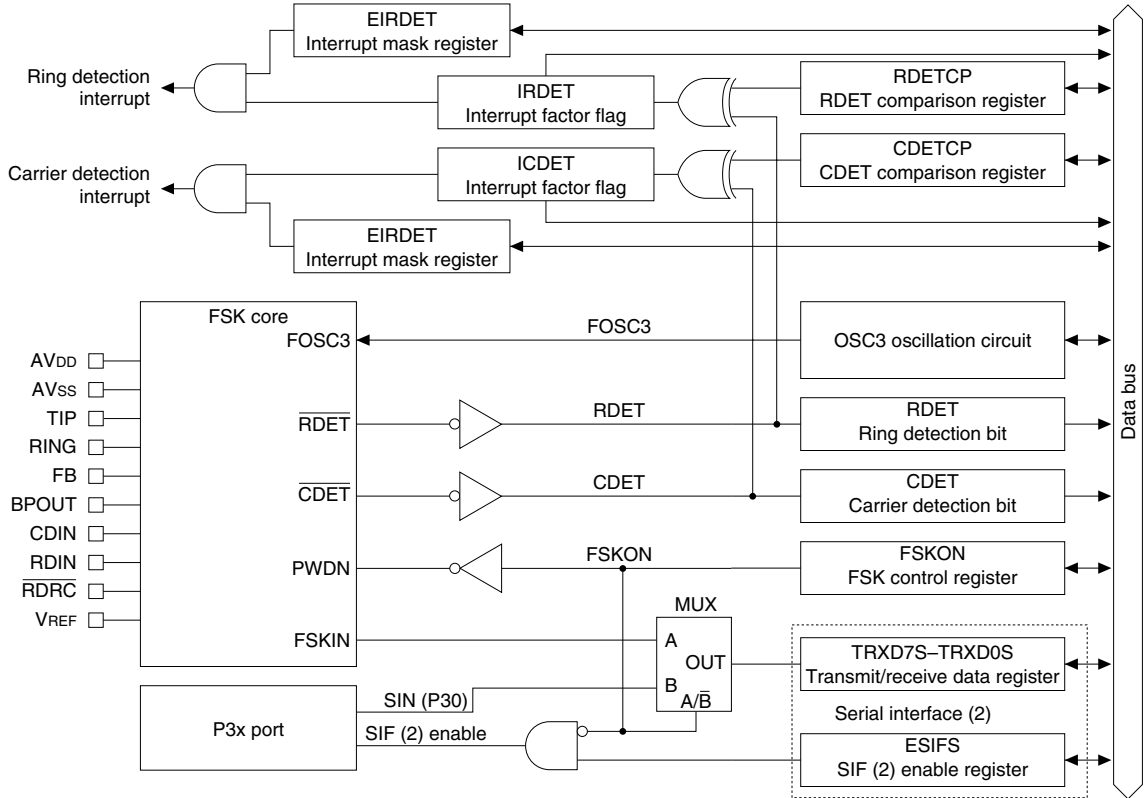

Fig. 4.15.1.1 FSK demodulator block diagram

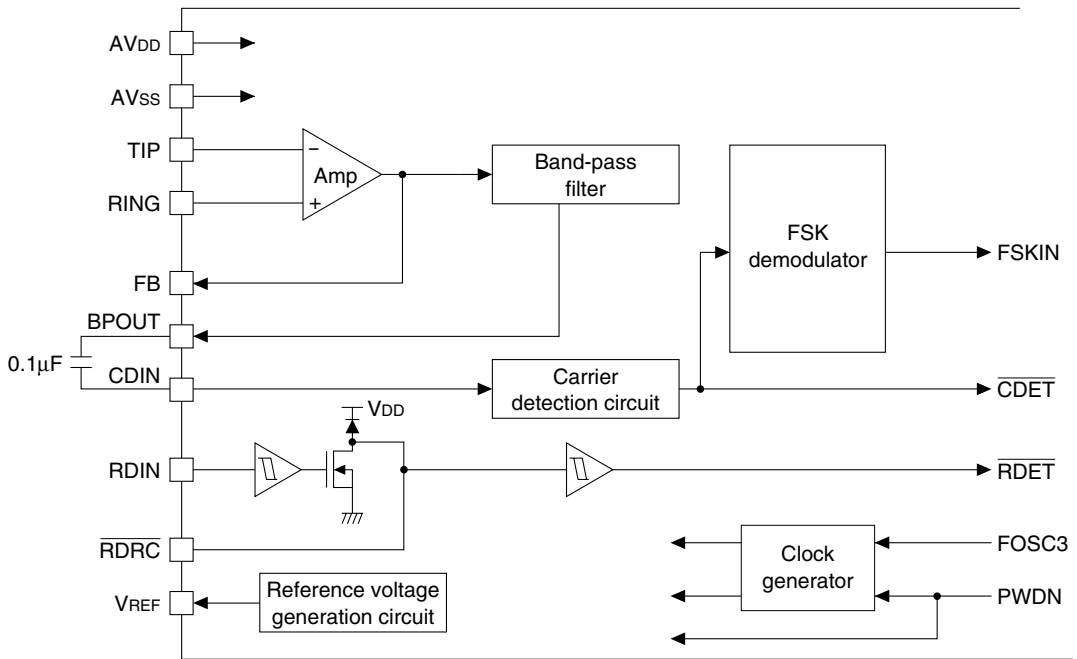

Fig. 4.15.1.2 FSK core configuration

The external terminals of the FSK demodulator are as follows:

- AVDD, AVSS Power terminals for the FSK block. Supply power respectively as AVDD = VDD, AVSS = VSS.
- TIP Inverted input terminal of the input amplifier
- RING Non-inverted input terminal of the input amplifier
- FB Feedback output terminal of the input amplifier
- BPOUT Output terminal of the band-pass filter
- CDIN Input terminal for carrier signal detection
- RDIN Input terminal for ring signal detection
- RDRC I/O terminal for connecting an RC network
- VREF Reference voltage (1/2VDD) output terminal

The basic external connection diagram is shown in Figure 4.15.1.3.

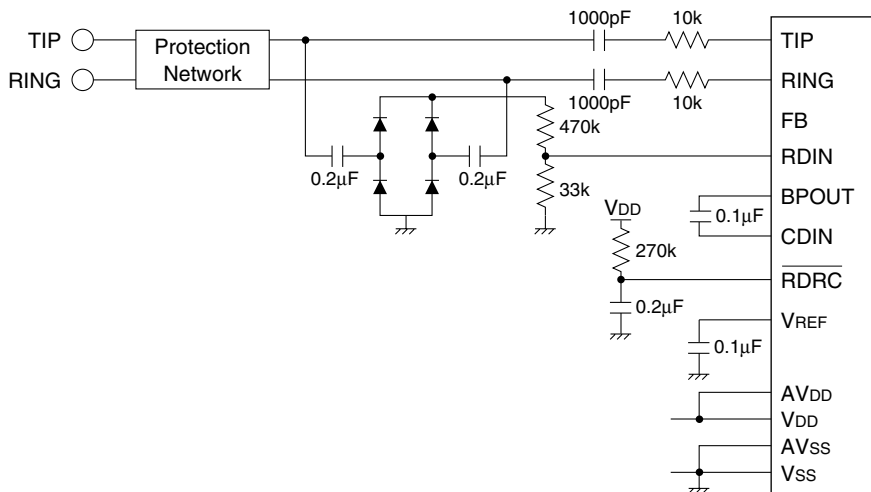

Fig. 4.15.1.3 Basic external connection diagram (example for Bellcore)

4.15.2 Mask option

The gain of the input amplifier shown in Figure 4.15.1.2 is fixed at 1 (0dB) when the internal feedback resistor is used.

Use of this internal feedback resistor can be selected by mask option.

When "Use" is selected:

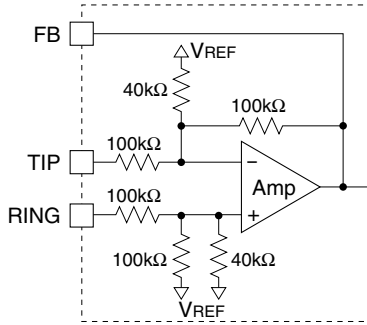

Fig. 4.15.2.1 Circuit configuration when the internal feedback resistor is used

The gain is fixed at 1 (0dB). Leave the FB terminal open.

When "Not use" is selected (example of differential input):

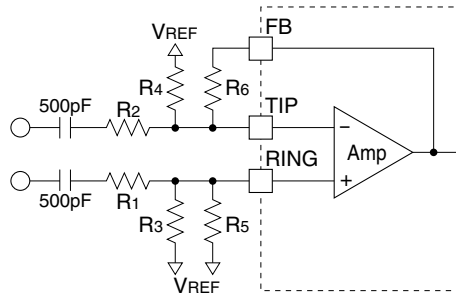

Fig. 4.15.2.2 Circuit configuration when the internal feedback resistor is not used (example of differential input)

The gain of the amplifier can be changed with external resistors.

A 500 kΩ resistor is recommended for R1, R2, R5 and R6, and approximately 200 kΩ for R3 and R4.

The gain can be found with the following formula.

$$G_{Amp} = \frac{R_5}{R_1} = \frac{R_6}{R_2} \quad (\text{In case of } R_1 = R_2, R_3 = R_4, R_5 = R_6)$$

When "Not use" is selected (example of single-end input):

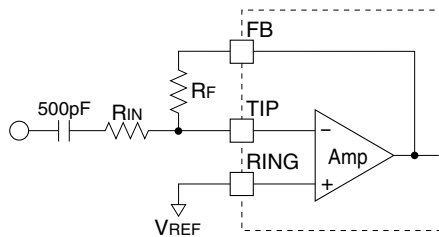

Fig. 4.15.2.3 Circuit configuration when the internal feedback resistor is not used (example of single-end input)

The gain of the amplifier can be changed with external resistors.

A resistor of approximately 500 kΩ is recommended for Rin and Rf.

The gain can be found with the following formula.

$$G_{Amp} = \frac{R_f}{R_{in}}$$

4.15.3 Ring/carrier detection and interrupt

The FSK block has a ring detection circuit and a carrier detection circuit built-in.

When a ring signal is input, the ring detection circuit sets the RDET bit (FF66H•D1) to "1" while the signal is being input. In the same way, when a carrier is input, the carrier detection circuit sets the CDET bit (FF66H•D0) to "1". Further, the interrupt can be generated at the rising edge or falling edge of these detection signals. The edge selection can be made by the RDET comparison register RDETC (FF67H•D1) and CDET comparison register CDETC (FF67H•D0).

When the register is set to "0", the interrupt is generated at the rising edge. When set to "1", the interrupt is generated at the falling edge.

When the interrupt condition is met, the corresponding interrupt factor flag (the ring detection interrupt = IRDET, the carrier detection interrupt = ICDET) is set to "1". In this case, when the corresponding interrupt mask register (the ring detection interrupt = EIRDET, the carrier detection interrupt = EICDET) has been set to "1", an interrupt request is generated to the CPU. When the interrupt mask register is set to "0", the interrupt will be masked. However, even in this case, the interrupt factor flag is set to "1" when the interrupt condition is met.

Figure 4.15.3.1 shows the relationship between the detection bit and the comparison register.

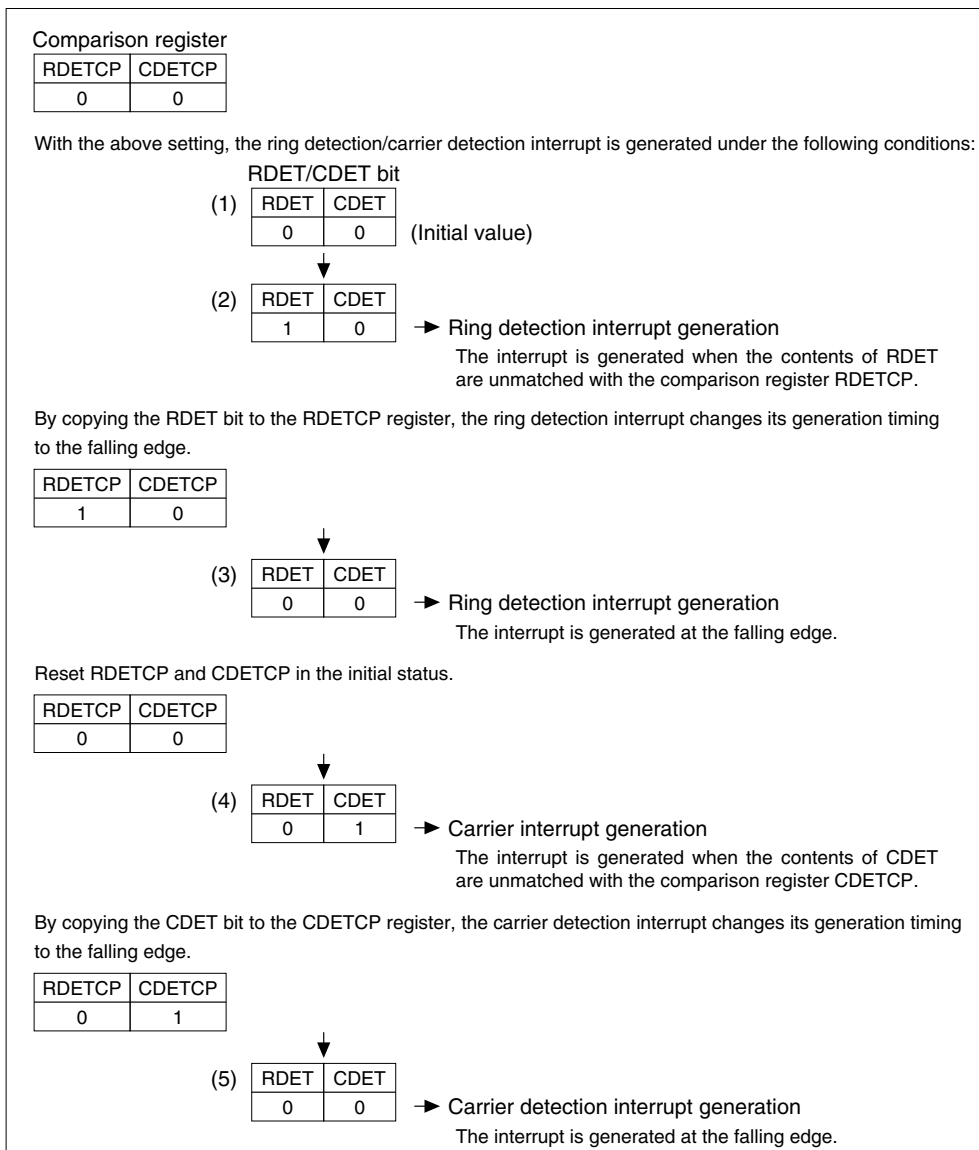

Fig. 4.15.3.1 Relationship between the detection bit and the comparison register

Since the value of both RDIT and CDET is the same as the comparison register, an interrupt does not occur at (1). When a ring is input, the ring detection interrupt will be generated since RDIT changes "0" to "1" and no longer matches the contents of RDETCR at (2). To generate an interrupt when a ring input is completed, write "1" to RDETCR. Copying the RDET bit to RDETCR changes the interrupt timing so that the interrupt will occur when the RDET changes from the current status. In Figure 4.15.3.1, the RDET bit has been copied to RDETCR immediately after (2), so an interrupt occurs again when RDET returns from "1" to "0".

As the same as ring detection interrupt, the carrier detection interrupt will be generated at (4) and (5) since no matching occurs between CDET and CDETCR.

Figure 4.15.3.2 shows the timing chart for the interrupt generation (example for Bellcore).

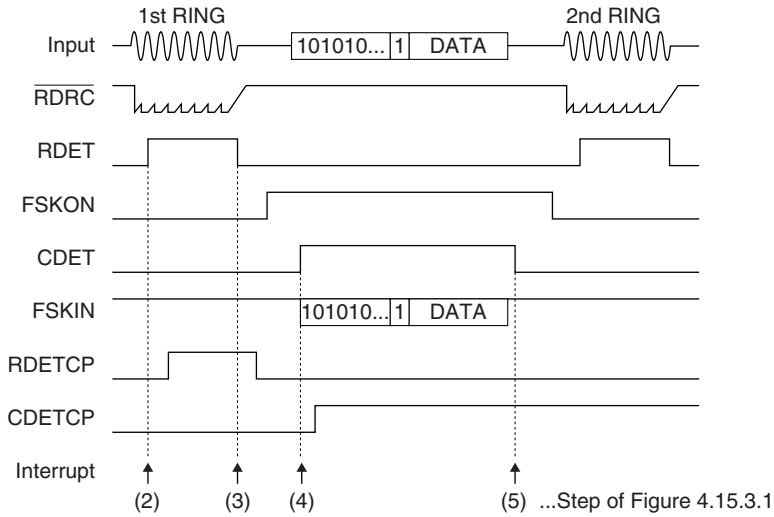

Fig. 4.15.3.2 Timing chart for interrupt generation (example for Bellcore)

4.15.4 Inputting FSK data

The FSK demodulator starts operating when "1" is written to FSKON (FF66H•D3). Normally it should be set to "0" to decrease current consumption if not necessary.

The following settings are necessary before starting the FSK demodulator operation.

(1) Setting the serial interface (2)

The demodulated data is loaded to the data register of the serial interface (2).

Therefore, transfer conditions (transfer rate, bit width, parity condition) must be set before receiving FSK data.

When the FSK demodulator is turned ON (FSKON = "1"), the input line of the serial interface (2) is switched from P30 to the FSK demodulator output. The I/O terminals (P30–P33) including P30, used for the serial interface (2), functions as the general I/O port terminals while FSKON is "1".

Refer to Section 4.11, "Serial Interface", for controlling the serial interface (2).

(2) Controlling the OSC3 oscillation circuit

The FSK demodulator uses the OSC3 clock as the operating clock. Therefore, the OSC oscillation circuit must be turned ON and the CPU operating clock must be switched to OSC3.

It takes a maximum 5 msec for oscillation stabilization after turning the OSC3 oscillation circuit ON. Do not turn the FSK demodulator ON in this period. Refer to Section 4.3, "Oscillation Circuit", for controlling the OSC3 oscillation circuit.

Data input procedure (example for Bellcore) is shown below.

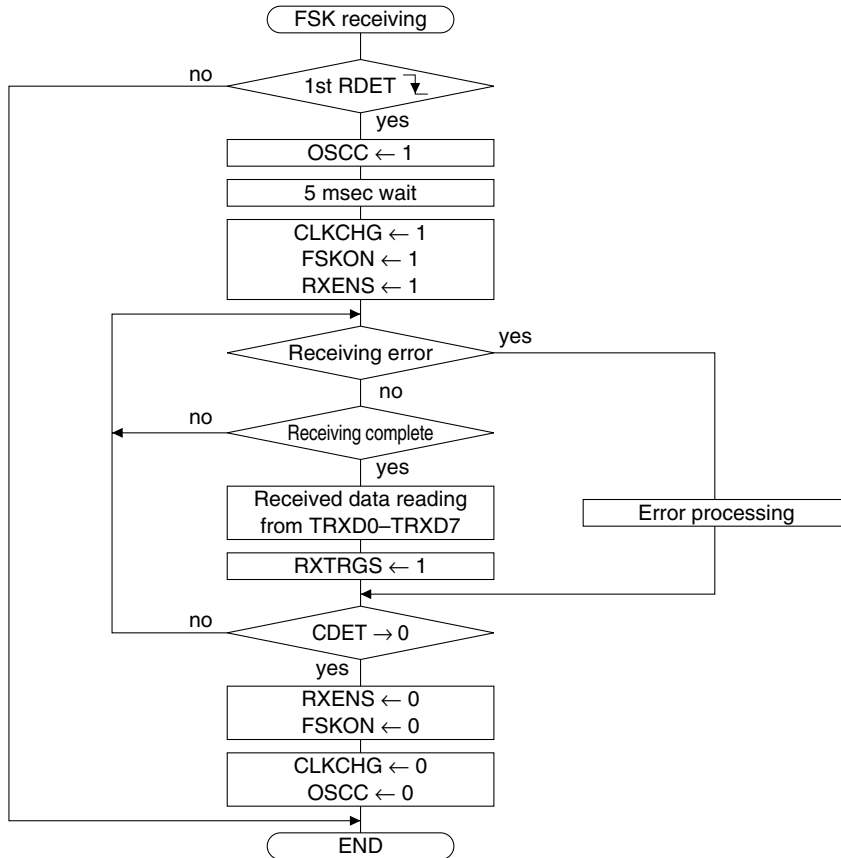

Fig. 4.15.4.1 Data input flow (example for Bellcore)

1. Detect the falling edge (RDET = "0") of the first ring input. The ring detection interrupt can be used.
2. Turn the OSC3 oscillation circuit ON by writing "1" to OSCC.
3. After waiting 5 msec or more, switch the CPU operating clock from OSC1 to OSC3 by writing "1" to CLKCHG.
4. Turn the FSK demodulator ON by writing "1" to FSKON.
5. Enable the serial interface (2) to receive data by writing "1" to RXENS.
6. Read data from TRXD0S-TRXD7S after waiting for the receiving interrupt of the serial interface (2). After reading data, reset the overrun error check by writing "1" to RXTRGS. Repeat this step until the carrier stops and a carrier detection interrupt is generated.
7. Disable data receiving by writing "0" to RXENS after the carrier stop detection interrupt is generated.
8. Turn the FSK demodulator OFF by writing "0" to FSKON.
9. Switch the CPU operating clock from OSC3 to OSC1 by writing "0" to CLKCHG.
10. Turn the OSC3 oscillation circuit OFF by writing "0" to OSCC.

4.15.5 I/O memory of FSK demodulator

Table 4.15.5.1 shows the I/O address and control bits for the FSK demodulator.

Table 4.15.5.1 Control bits of FSK demodulator

Address	Register								Comment
	D3	D2	D1	D0	Name	Init *1	1	0	
FF66H	FSKON	0	RDET	CDET	FSKON 0 *3	0 - *2	On	Off	FSK demodulator On/Off Unused
	R/W	R			RDET CDET	- *4 0	Ring Carrier	No Ring No Carrier	Ring detection bit Carrier detection bit
FF67H	0	0	RDETCP	CDETCP	0 *3 0 *3	- *2 - *2			Unused Unused
	R		R/W		RDETCP CDETCP	0 0	\downarrow \downarrow	\uparrow \uparrow	RDET comparison register CDET comparison register
FFE6H	0	0	EIRDET	EICDET	0 *3 0 *3	- *2 - *2			Unused Unused
	R		R/W		EIRDET EICDET	0 0	Enable Enable	Mask Mask	Interrupt mask register (FSK demodulator ring detection) Interrupt mask register (FSK demodulator carrier detection)
FFF6H	0	0	IRDET	ICDET	0 *3 0 *3	- *2 - *2	(R) Yes	(R) No	Unused Unused
	R		R/W		IRDET ICDET	0 0	(W) Reset	(W) Invalid	Interrupt factor flag (FSK demodulator ring detection) Interrupt factor flag (FSK demodulator carrier detection)

- *1 Initial value at initial reset
- *2 Not set in the circuit
- *3 Constantly "0" when being read
- *4 Depends on the input status of the RDIN terminal

FSKON: FSK demodulator control register (FF66H•D3)

Turns the FSK demodulator ON and OFF.

- When "1" is written: ON
- When "0" is written: OFF
- Reading: Valid

The FSK demodulator goes ON by writing "1" to FSKON. At the same time, the data input line of the serial interface (2) is switched from the P30 terminal to the FSK demodulator output. The P3x terminals function as general I/O port terminals regardless of the ESIFS setting.

When starting the FSK demodulator operation, the OSC3 oscillation circuit must be turned ON and the CPU operating clock must be switched to the OSC3 clock.

The FSK demodulator goes OFF by writing "0" to FSKON. The P3x terminals can be set to the I/O terminals used for the serial interface (2).

The FSK demodulator should be activated only when it is needed in order to decrease current consumption.

At initial reset, this register is set to "0".

RDET: Ring detection bit (FF66H•D1)

Indicates the ring detection status.

- When "1" is read: Ring is detected
- When "0" is read: Ring is not detected
- Writing: Invalid

A ring signal is being input when RDIT is "1". When the ring input is completed, RDET returns to "0".

This bit is dedicated for reading, so writing can not be done.

The bit value at initial reset depends on the input status of the RDIN terminal.

CDET: Carrier detection bit (FF66H•D0)

Indicates the carrier detection status.

When "1" is read: Carrier is detected

When "0" is read: Carrier is not detected

Writing: Invalid

CDET goes "1" when a carrier is input. When the carrier is stopped, CDET returns to "0". This bit is dedicated for reading, so writing can not be done.

At initial reset, this bit is set to "0".

RDETCP: RDET comparison register (FF67H•D1)

Sets a generation condition for the ring detection interrupt.

When "1" is written: RDET falling edge

When "0" is written: RDET rising edge

Reading: Valid

When RDETCP is set to "1", the ring detection interrupt is generated at the falling edge of the RDET signal. When RDETCP is "0", the interrupt is generated at the rising edge.

At initial reset, this register is set to "0".

CDETCP: CDET comparison register (FF67H•D0)

Sets a generation condition for the carrier detection interrupt.

When "1" is written: CDET falling edge

When "0" is written: CDET rising edge

Reading: Valid

When CDETCP is set to "1", the carrier detection interrupt is generated at the falling edge of the CDET signal. When CDETCP is "0", the interrupt is generated at the rising edge.

At initial reset, this register is set to "0".

EIRDET, EICDET: Interrupt mask registers (FFEAH•D1, D0)

Enables or disables the generation of an interrupt for the CPU.

When "1" is written: Enabled

When "0" is written: Disabled

Reading: Valid

EIRDET and EICDET are interrupt mask registers that respectively correspond to the interrupt factors for ring detection and carrier detection. Interrupts set to "1" are enabled and interrupts set to "0" are disabled.

At initial reset, these registers are set to "0".

IRDET, ICDET: Interrupt factor flags (FFFAH•D1, D0)

Indicates the FSK interrupt generation status.

When "1" is read: Interrupt has occurred

When "0" is read: Interrupt has not occurred

When "1" is written: Flag is reset

When "0" is written: Invalid

IRDET and ICDET are interrupt factor flags that respectively correspond to the interrupts for ring detection and carrier detection, and are set to "1" by generation of each factor.

When set in this manner, if the corresponding interrupt enable mask is set to "1" and the CPU is set to interrupt enabled status (I flag = "1"), an interrupt will be generated to the CPU.

Regardless of the interrupt mask register setting, the interrupt factor flag will be set to "1" by the occurrence of an interrupt generation condition.

The interrupt factor flag is reset to "0" by writing "1".

After an interrupt occurs, the same interrupt will occur again if the interrupt enabled state (I flag = "1") is set or the RETI instruction is executed unless the interrupt factor flag is reset. Therefore, be sure to reset (write "1" to) the interrupt factor flag in the interrupt service routine before shifting to the interrupt enabled state.

At initial reset, these flags are set to "0".

4.15.6 Programming notes

- (1) When starting the FSK demodulator operation, the OSC3 oscillation circuit must be turned ON and the CPU operating clock must be switched to the OSC3 clock.
The OSC3 oscillation circuit takes a maximum 5 msec for oscillation stabilization after turning the circuit ON. Consequently, allow an adequate waiting time after turning ON the OSC3 oscillation, before starting the FSK operation. Note that the oscillation start time will vary somewhat depending on the oscillator and on the externally attached parts.
- (2) In order to decrease current consumption, the FSK demodulator and the OSC3 oscillation circuit should be turned OFF when their operations are not necessary.
- (3) When detecting a carrier, the FSK demodulator may output invalid data at the rising edge of the CDET signal. In this case, the first byte received to the serial interface (2) may result in a parity error or a framing error. As this byte is generally used as a leader code, ignore the error in the processing.
- (4) After an interrupt occurs, the same interrupt will occur again if the interrupt enabled state (I flag = "1") is set or the RETI instruction is executed unless the interrupt factor flag is reset. Therefore, be sure to reset (write "1" to) the interrupt factor flag in the interrupt service routine before shifting to the interrupt enabled state.

4.16 Interrupt and HALT

<Interrupt types>

The S1C63558 provides the following interrupt functions.

External interrupt:	• Input interrupt	(2 systems)
Internal interrupt:	• Watchdog timer interrupt	(NMI, 1 system)
	• Programmable timer interrupt	(2 systems)
	• Serial interface interrupt	(6 systems)
	• Timer interrupt	(4 systems)
	• Stopwatch timer interrupt	(2 systems)
	• Dialing interrupt	(1 system)
	• FSK interrupt	(2 systems)

To authorize interrupt, the interrupt flag must be set to "1" (EI) and the necessary related interrupt mask registers must be set to "1" (enable).

When an interrupt occurs the interrupt flag is automatically reset to "0" (DI), and interrupts after that are inhibited.

The watchdog timer interrupt is an NMI (non-maskable interrupt), therefore, the interrupt is generated regardless of the interrupt flag setting. Also the interrupt mask register is not provided. However, it is possible to not generate NMI since software can stop the watchdog timer operation.

Figure 4.16.1 shows the configuration of the interrupt circuit.

Note: After an initial reset, all the interrupts including NMI are masked until both the stack pointers SP1 and SP2 are set with the software. Be sure to set the SP1 and SP2 in the initialize routine. Further, when re-setting the stack pointer, the SP1 and SP2 must be set as a pair. When one of them is set, all the interrupts including NMI are masked and interrupts cannot be accepted until the other one is set.

<HALT>

The S1C63558 has HALT functions that considerably reduce the current consumption when it is not necessary.

The CPU enters HALT status when the HALT instruction is executed.

In HALT status, the operation of the CPU is stopped. However, timers continue counting since the oscillation circuit operates. Reactivating the CPU from HALT status is done by generating a hardware interrupt request including NMI.

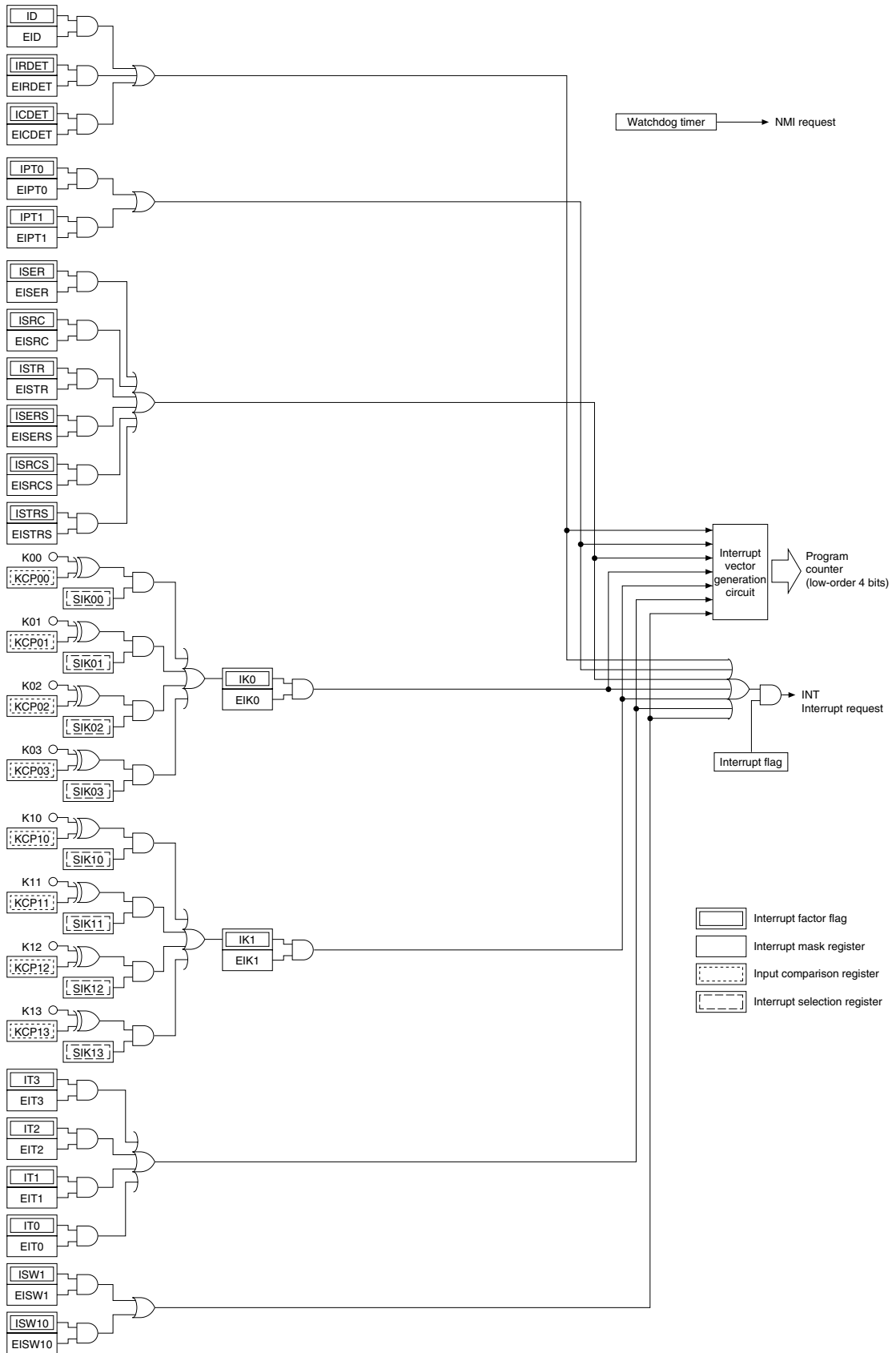

Fig. 4.16.1 Configuration of the interrupt circuit

4.16.1 Interrupt factor

Table 4.16.1.1 shows the factors for generating interrupt requests.

The interrupt flags are set to "1" depending on the corresponding interrupt factors.

The CPU operation is interrupted when an interrupt factor flag is set to "1" if the following conditions are established.

- The corresponding mask register is "1" (enabled)
- The interrupt flag is "1" (EI)

The interrupt factor flag is reset to "0" when "1" is written.

At initial reset, the interrupt factor flags are reset to "0".

- * Since the watchdog timer's interrupt is NMI, the interrupt is generated regardless of the setting above, and no interrupt factor flag is provided.

Table 4.16.1.1 Interrupt factors

Interrupt factor	Interrupt factor flag
Dialer (dialing cycle completion)	ID (FFF9H•D0)
Ring detection (falling edge or rising edge)	IRDET (FFFAH•D0)
Carrier detection (falling edge or rising edge)	ICDET (FFFAH•D1)
Programmable timer 1 (counter = 0)	IPT1 (FFF2H•D1)
Programmable timer 0 (counter = 0)	IPT0 (FFF2H•D0)
Serial interface (1) (receive error)	ISER (FFF3H•D2)
Serial interface (1) (receive completion)	ISRC (FFF3H•D0)
Serial interface (1) (transmit completion)	ISTR (FFF3H•D1)
Serial interface (2) (receive error)	ISERS (FFF8H•D2)
Serial interface (2) (receive completion)	ISRCS (FFF8H•D0)
Serial interface (2) (transmit completion)	ISTRS (FFF8H•D1)
K00–K03 input (falling edge or rising edge)	IK0 (FFF4H•D0)
K10–K13 input (falling edge or rising edge)	IK1 (FFF5H•D0)
Clock timer 1 Hz (falling edge)	IT3 (FFF6H•D3)
Clock timer 2 Hz (falling edge)	IT2 (FFF6H•D2)
Clock timer 8 Hz (falling edge)	IT1 (FFF6H•D1)
Clock timer 32 Hz (falling edge)	IT0 (FFF6H•D0)
Stopwatch timer (1 Hz)	ISW1 (FFF7H•D1)
Stopwatch timer (10 Hz)	ISW10 (FFF7H•D0)

Note: After an interrupt occurs, the same interrupt will occur again if the interrupt enabled state (I flag = "1") is set or the RETI instruction is executed unless the interrupt factor flag is reset. Therefore, be sure to reset (write "1" to) the interrupt factor flag in the interrupt service routine before shifting to the interrupt enabled state.

4.16.2 Interrupt mask

The interrupt factor flags can be masked by the corresponding interrupt mask registers.

The interrupt mask registers are read/write registers. They are enabled (interrupt authorized) when "1" is written to them, and masked (interrupt inhibited) when "0" is written to them.

At initial reset, the interrupt mask register is set to "0".

Table 4.16.2.1 shows the correspondence between interrupt mask registers and interrupt factor flags.

Table 4.16.2.1 Interrupt mask registers and interrupt factor flags

Interrupt mask register		Interrupt factor flag	
EID	(FFE9H•D0)	ID	(FFF9H•D0)
EIRDET	(FFEAH•D1)	IRDET	(FFFAH•D1)
EICDET	(FFEAH•D0)	ICDET	(FFFAH•D0)
EIPT1	(FFE2H•D1)	IPT1	(FFF2H•D1)
EIPT0	(FFE2H•D0)	IPT0	(FFF2H•D0)
EISER	(FFE3H•D2)	ISER	(FFF3H•D2)
EISRC	(FFE3H•D0)	ISRC	(FFF3H•D0)
EISTR	(FFE3H•D1)	ISTR	(FFF3H•D1)
EISERS	(FFE8H•D2)	ISERS	(FFF8H•D2)
EISRCS	(FFE8H•D0)	ISRCS	(FFF8H•D0)
EISTRS	(FFE8H•D1)	ISTRS	(FFF8H•D1)
EIK0	(FFE4H•D0)	IK0	(FFF4H•D0)
EIK1	(FFE5H•D0)	IK1	(FFF5H•D0)
EIT3	(FFE 6H•D3)	IT3	(FFF6H•D3)
EIT2	(FFE6H•D2)	IT2	(FFF6H•D2)
EIT1	(FFE6H•D1)	IT1	(FFF6H•D1)
EIT0	(FFE6H•D0)	IT0	(FFF6H•D0)
EISW1	(FFE7H•D1)	ISW1	(FFF7H•D1)
EISW10	(FFE7H•D0)	ISW10	(FFF7H•D0)

4.16.3 Interrupt vector

When an interrupt request is input to the CPU, the CPU begins interrupt processing. After the program being executed is terminated, the interrupt processing is executed in the following order.

- 1 The content of the flag register is evacuated, then the I flag is reset.
- 2 The address data (value of program counter) of the program to be executed next is saved in the stack area (RAM).
- 3 The interrupt request causes the value of the interrupt vector (0100H–010EH) to be set in the program counter.
- 4 The program at the specified address is executed (execution of interrupt processing routine by software).

Table 4.16.3.1 shows the correspondence of interrupt requests and interrupt vectors.

Table 4.16.3.1 Interrupt request and interrupt vectors

Interrupt vector	Interrupt factor	Priority
0100H	Watchdog timer	↑ High
0102H	Dialer, FSK	
0104H	Programmable timer	
0106H	Serial interface (1), (2)	
0108H	K00–K03 input	
010AH	K10–K13 input	
010CH	Clock timer	↓ Low
010EH	Stopwatch timer	

The four low-order bits of the program counter are indirectly addressed through the interrupt request.

4.16.4 I/O memory of interrupt

Tables 4.16.4.1(a) and (b) show the I/O addresses and the control bits for controlling interrupts.

Table 4.16.4.1(a) Control bits of interrupt (1)

Address	Register				Name	Init *1	1	0	Comment
	D3	D2	D1	D0					
FF20H	SIK03	SIK02	SIK01	SIK00	SIK03	0	Enable	Disable	K00–K03 interrupt selection register
					SIK02	0	Enable	Disable	
	R/W				SIK01	0	Enable	Disable	
	R/W				SIK00	0	Enable	Disable	
FF22H	KCP03	KCP02	KCP01	KCP00	KCP03	1	↓	↑	K00–K03 input comparison register
					KCP02	1	↓	↑	
	R/W				KCP01	1	↓	↑	
	R/W				KCP00	1	↓	↑	
FF24H	SIK13	SIK12	SIK11	SIK10	SIK13	0	Enable	Disable	K10–K13 interrupt selection register
					SIK12	0	Enable	Disable	
	R/W				SIK11	0	Enable	Disable	
	R/W				SIK10	0	Enable	Disable	
FF26H	KCP13	KCP12	KCP11	KCP10	KCP13	1	↓	↑	K10–K13 input comparison register
					KCP12	1	↓	↑	
	R/W				KCP11	1	↓	↑	
	R/W				KCP10	1	↓	↑	
FF67H	0	0	RDETCP	CDETCP	0 *3	–*2			Unused
					0 *3	–*2			Unused
	R		R/W		RDETCP	0	↓	↑	RDET comparison register
	R		R/W		CDETCP	0	↓	↑	CDET comparison register
FFE2H	0	0	EIPT1	EIPT0	0 *3	–*2			Unused
					0 *3	–*2			Unused
	R		R/W		EIPT1	0	Enable	Mask	Interrupt mask register (Programmable timer 1)
	R		R/W		EIPT0	0	Enable	Mask	Interrupt mask register (Programmable timer 0)
FFE3H	0	EISER	EISTR	EISRC	0 *3	–*2			Unused
					0 *3	–*2			Unused
	R		R/W		EISER	0	Enable	Mask	Interrupt mask register (Serial I/F (1) error)
	R		R/W		EISTR	0	Enable	Mask	Interrupt mask register (Serial I/F (1) transmit completion)
R		R/W		EISRC	0	Enable	Mask	Interrupt mask register (Serial I/F (1) receive completion)	
FFE4H	0	0	0	EIK0	0 *3	–*2			Unused
					0 *3	–*2			Unused
	R		R/W		0 *3	–*2			Unused
	R		R/W		EIK0	0	Enable	Mask	Interrupt mask register (K00–K03)
FFE5H	0	0	0	EIK1	0 *3	–*2			Unused
					0 *3	–*2			Unused
	R		R/W		0 *3	–*2			Unused
	R		R/W		EIK1	0	Enable	Mask	Interrupt mask register (K10–K13)
FFE6H	EIT3	EIT2	EIT1	EIT0	EIT3	0	Enable	Mask	Interrupt mask register (Clock timer 1 Hz)
					EIT2	0	Enable	Mask	Interrupt mask register (Clock timer 2 Hz)
	R/W				EIT1	0	Enable	Mask	Interrupt mask register (Clock timer 8 Hz)
	R/W				EIT0	0	Enable	Mask	Interrupt mask register (Clock timer 32 Hz)
FFE7H	0	0	EISW1	EISW10	0 *3	–*2			Unused
					0 *3	–*2			Unused
	R		R/W		EISW1	0	Enable	Mask	Interrupt mask register (Stopwatch timer 1 Hz)
	R		R/W		EISW10	0	Enable	Mask	Interrupt mask register (Stopwatch timer 10 Hz)
FFE8H	0	EISERS	EISTRS	EISRCS	0 *3	–*2			Unused
					0 *3	–*2			Unused
	R		R/W		EISERS	0	Enable	Mask	Interrupt mask register (Serial I/F (2) error)
	R		R/W		EISTRS	0	Enable	Mask	Interrupt mask register (Serial I/F (2) transmit completion)
R		R/W		EISRCS	0	Enable	Mask	Interrupt mask register (Serial I/F (2) receive completion)	
FFE9H	0	0	0	EID	0 *3	–*2			Unused
					0 *3	–*2			Unused
	R		R/W		0 *3	–*2			Unused
	R		R/W		EID	0	Enable	Mask	Interrupt mask register (Dialer)
FFEAH	0	0	EIRDET	EICDET	0 *3	–*2			Unused
					0 *3	–*2			Unused
	R		R/W		EIRDET	0	Enable	Mask	Interrupt mask register (FSK demodulator ring detection)
	R		R/W		EICDET	0	Enable	Mask	Interrupt mask register (FSK demodulator carrier detection)

*1 Initial value at initial reset

*3 Constantly "0" when being read

*2 Not set in the circuit

Table 4.16.4.1(b) Control bits of interrupt (2)

Address	Register				Name	Init *1	1	0	Comment
	D3	D2	D1	D0					
FFF2H	0	0	IPT1	IPT0	0 *3	-*2	(R)	(R)	Unused
	R		R/W		0 *3	-*2	Yes	No	Unused
	R		R/W		IPT1	0	(W)	(W)	Interrupt factor flag (Programmable timer 1)
	R		R/W		IPT0	0	Reset	Invalid	Interrupt factor flag (Programmable timer 0)
FFF3H	0	ISER	ISTR	ISRC	0 *3	-*2	(R)	(R)	Unused
	R		R/W		0	Yes	No		Interrupt factor flag (Serial I/F (1) error)
	R		R/W		ISTR	0	(W)	(W)	Interrupt factor flag (Serial I/F (1) transmit completion)
	R		R/W		ISRC	0	Reset	Invalid	Interrupt factor flag (Serial I/F (1) receive completion)
FFF4H	0	0	0	IK0	0 *3	-*2	(R)	(R)	Unused
	R		R/W		0 *3	-*2	Yes	No	Unused
	R		R/W		0 *3	-*2	(W)	(W)	Unused
	R		R/W		IK0	0	Reset	Invalid	Interrupt factor flag (K00-K03)
FFF5H	0	0	0	IK1	0 *3	-*2	(R)	(R)	Unused
	R		R/W		0 *3	-*2	Yes	No	Unused
	R		R/W		0 *3	-*2	(W)	(W)	Unused
	R		R/W		IK1	0	Reset	Invalid	Interrupt factor flag (K10-K13)
FFF6H	IT3	IT2	IT1	IT0	IT3	0	(R)	(R)	Interrupt factor flag (Clock timer 1 Hz)
	R		R/W		IT2	0	Yes	No	Interrupt factor flag (Clock timer 2 Hz)
	R		R/W		IT1	0	(W)	(W)	Interrupt factor flag (Clock timer 8 Hz)
	R		R/W		IT0	0	Reset	Invalid	Interrupt factor flag (Clock timer 32 Hz)
FFF7H	0	0	ISW1	ISW10	0 *3	-*2	(R)	(R)	Unused
	R		R/W		0 *3	-*2	Yes	No	Unused
	R		R/W		ISW1	0	(W)	(W)	Interrupt factor flag (Stopwatch timer 1 Hz)
	R		R/W		ISW10	0	Reset	Invalid	Interrupt factor flag (Stopwatch timer 10 Hz)
FFF8H	0	ISERS	ISTRS	ISRCS	0 *3	-*2	(R)	(R)	Unused
	R		R/W		0	Yes	No		Interrupt factor flag (Serial I/F (2) error)
	R		R/W		ISTRS	0	(W)	(W)	Interrupt factor flag (Serial I/F (2) transmit completion)
	R		R/W		ISRCS	0	Reset	Invalid	Interrupt factor flag (Serial I/F (2) receive completion)
FFF9H	0	0	0	ID	0 *3	-*2	(R)	(R)	Unused
	R		R/W		0 *3	-*2	Yes	No	Unused
	R		R/W		0 *3	-*2	(W)	(W)	Unused
	R		R/W		ID	0	Reset	Invalid	Interrupt factor flag (Dialer)
FFFAH	0	0	IRDET	ICDET	0 *3	-*2	(R)	(R)	Unused
	R		R/W		0 *3	-*2	Yes	No	Unused
	R		R/W		IRDET	0	(W)	(W)	Interrupt factor flag (FSK demodulator ring detection)
	R		R/W		ICDET	0	Reset	Invalid	Interrupt factor flag (FSK demodulator carrier detection)

*1 Initial value at initial reset

*3 Constantly "0" when being read

*2 Not set in the circuit

EID: Interrupt mask register (FFE9H•D0)

ID: Interrupt factor flag (FFF9H•D0)

Refer to Section 4.14, "Telephone Function".

RDETCP, CDETCP: RDETP, CDET comparison registers (FF67H•D1, D0)

IRDET, ICDET: Interrupt mask registers (FFEAH•D1, D0)

IRDET, ICDET: Interrupt factor flags (FFFAH•D1, D0)

Refer to Section 4.15, "FSK Demodulator".

EIPT1, EIPT0: Interrupt mask registers (FFE2H•D1, D0)

IPT1, IPT0: Interrupt factor flags (FFF2H•D1, D0)

Refer to Section 4.10, "Programmable Timer".

EISER, EISTR, EISRC: Interrupt mask registers (FFE3H•D2-D0)

EISERS, EISTRS, EISRCS: Interrupt mask registers (FFE8H•D2-D0)

ISER, ISTR, ISRC: Interrupt factor flags (FFF3H•D2-D0)

ISERS, ISTRS, ISRCS: Interrupt factor flags (FFF8H•D2-D0)

Refer to Section 4.11, "Serial Interface".

KCP03–KCP00, KCP13–KCP10: Input comparison registers (FF22H, FF26H)

SIK03–SIK00, SIK13–SIK10: Interrupt selection registers (FF20H, FF24H)

EIK0, EIK1: Interrupt mask registers (FFE4H•D0, FFE5H•D0)

IK0, IK1: Interrupt factor flags (FFF4H•D0, FFF5H•D0)

Refer to Section 4.4, "Input Ports".

EIT3–EIT0: Interrupt mask registers (FFE6H)

IT3–IT0: Interrupt factor flags (FFF6H)

Refer to Section 4.8, "Clock Timer".

EISW1, EISW10: Interrupt mask registers (FFE7H•D1, D0)

ISW1, ISW10: Interrupt factor flags (FFF7H•D1, D0)

Refer to Section 4.9, "Stopwatch Timer".

4.16.5 Programming notes

- (1) The interrupt factor flags are set when the interrupt condition is established, even if the interrupt mask registers are set to "0".
- (2) After an interrupt occurs, the same interrupt will occur again if the interrupt enabled state (I flag = "1") is set or the RETI instruction is executed unless the interrupt factor flag is reset. Therefore, be sure to reset (write "1" to) the interrupt factor flag in the interrupt service routine before shifting to the interrupt enabled state.
- (3) After an initial reset, all the interrupts including NMI are masked until both the stack pointers SP1 and SP2 are set with the software. Be sure to set the SP1 and SP2 in the initialize routine. Further, when re-setting the stack pointer, the SP1 and SP2 must be set as a pair. When one of them is set, all the interrupts including NMI are masked and interrupts cannot be accepted until the other one is set.

CHAPTER 5 SUMMARY OF NOTES

5.1 Notes for Low Current Consumption

The S1C63558 contains control registers for each of the circuits so that current consumption can be reduced.

These control registers reduce the current consumption through programs that operate the circuits at the minimum levels.

The following lists the circuits that can control operation and their control registers. Refer to these when programming.

Table 5.1.1 Circuits and control registers

Circuit (and item)	Control register
CPU	HALT instruction
CPU operating frequency	CLKCHG, OSCC
LCD system voltage circuit	LPWR
SVD circuit	SVDON
FSK demodulator	FSKON

Refer to Chapter 7, "Electrical Characteristics" for current consumption.

Below are the circuit statuses at initial reset.

CPU: Operating status

CPU operating frequency: Low speed side (CLKCHG = "0")

OSC3 oscillation circuit is in OFF status (OSCC = "0")

LCD system voltage circuit: OFF status (LPWR = "0")

SVD circuit: OFF status (SVDON = "0")

FSK demodulator: OFF status (FSKON = "0")

Also, be careful about panel selection because the current consumption can differ by the order of several μ A on account of the LCD panel characteristics.

5.2 Summary of Notes by Function

Here, the cautionary notes are summed up by function category. Keep these notes well in mind when programming.

Memory and stack

- (1) Memory is not implemented in unused areas within the memory map. Further, some non-implementation areas and unused (access prohibition) areas exist in the display memory area and the peripheral I/O area. If the program that accesses these areas is generated, its operation cannot be guaranteed. Refer to Section 4.7.5, "Display memory", for the display memory, and the I/O memory maps shown in Tables 4.1.1 (a)–(h) for the peripheral I/O area.
- (2) Part of the RAM area is used as a stack area for subroutine call and register evacuation, so pay attention not to overlap the data area and stack area.
- (3) The S1C63000 core CPU handles the stack using the stack pointer for 4-bit data (SP2) and the stack pointer for 16-bit data (SP1).
16-bit data are accessed in stack handling by SP1, therefore, this stack area should be allocated to the area where 4-bit/16-bit access is possible (0100H to 01FFH). The stack pointers SP1 and SP2 change cyclically within their respective range: the range of SP1 is 0000H to 03FFH and the range of SP2 is 0000H to 00FFH. Therefore, pay attention to the SP1 value because it may be set to 0200H or more exceeding the 4-bit/16-bit accessible range in the S1C63558 or it may be set to 00FFH or less. Memory accesses except for stack operations by SP1 are 4-bit data access. After initial reset, all the interrupts including NMI are masked until both the stack pointers SP1 and SP2 are set by software. Further, if either SP1 or SP2 is re-set when both are set already, the interrupts including NMI are masked again until the other is re-set. Therefore, the settings of SP1 and SP2 must be done as a pair.

Watchdog timer

- (1) When the watchdog timer is being used, the software must reset it within 3-second cycles.
- (2) Because the watchdog timer is set in operation state by initial reset, set the watchdog timer to disabled state (not used) before generating an interrupt (NMI) if it is not used.

Oscillation circuit

- (1) It takes at least 5 msec from the time the OSC3 oscillation circuit goes ON until the oscillation stabilizes. Consequently, when switching the CPU operation clock from OSC1 to OSC3, do this after a minimum of 5 msec have elapsed since the OSC3 oscillation went ON.
Further, the oscillation stabilization time varies depending on the external oscillator characteristics and conditions of use, so allow ample margin when setting the wait time.
- (2) When switching the clock form OSC3 to OSC1, use a separate instruction for switching the OSC3 oscillation OFF. An error in the CPU operation can result if this processing is performed at the same time by the one instruction.
- (3) The internal operating voltage of VD1 is fixed at 2.2 V. So it is not necessary to control the operating voltage regardless of the operating clock selected.

Input port

- (1) When input ports are changed from low to high by pull-up resistors, the rise of the waveform is delayed on account of the time constant of the pull-up resistor and input gate capacitance. Hence, when fetching input ports, set an appropriate waiting time. Particular care needs to be taken of the key scan during key matrix configuration. Make this waiting time the amount of time or more calculated by the following expression.

$$10 \times C \times R$$

C: terminal capacitance 5 pF + parasitic capacitance ? pF
R: pull-up resistance 330 kΩ
- (2) The K13 terminal functions as the clock input terminal for the programmable timer, and the input signal is shared with the input port and the programmable timer. Therefore, when the K13 terminal is set to the clock input terminal for the programmable timer, take care of the interrupt setting.

Output port

- (1) When using an output port (R00–R03, R10–R13) for special output, fix the corresponding data register (R00–R03, R10–R13) at "1" and the high impedance control register (R00HIZ–R03HIZ, R10HIZ–R13HIZ) at "0" (data output).
 Be aware that the output terminal is fixed at a low (Vss) level the same as the DC output if "0" is written to the data registers when the special output has been selected.
 Be aware that the output terminal shifts into high impedance status when "1" is written to the high impedance control register.
- (2) A hazard may occur when the TOUT, FOUT , BZ or XBZ signal is turned ON and OFF.
- (3) When fOSC3 is selected for the FOUT signal frequency, it is necessary to control the OSC3 oscillation circuit before output.
 Refer to Section 4.3, "Oscillation Circuit", for the control and notes.

I/O port

- (1) When in the input mode, I/O ports are changed from low to high by pull-up resistor, the rise of the waveform is delayed on account of the time constant of the pull-up resistor and input gate capacitance. Hence, when fetching input ports, set an appropriate wait time.
 Particular care needs to be taken of the key scan during key matrix configuration.
 Make this waiting time the amount of time or more calculated by the following expression.
 $10 \times C \times R$
 C: terminal capacitance 5 pF + parasitic capacitance ? pF
 R: pull-up resistance 330 kΩ
- (2) When special output (CL, FR) has been selected, a hazard may occur when the signal is turned ON or OFF.

LCD driver

- (1) When a program that access no memory mounted area (F050H–F0FFH, F150H–F1FFH, F201H, F203H, . . . , F24FH) is made, the operation is not guaranteed.
- (2) Because at initial reset, the contents of display memory and LC3–LC0 (LCD contrast) are undefined, there is need to initialize by the software. Furthermore, take care of the registers LPWR and ALOFF because these are set so that the display goes OFF.
- (3) The COM8–COM16 terminals can be set as the SEG47–SEG40 terminals by mask option. In this case, only 1/8 drive duty can be selected, so a dot matrix type LCD with a maximum of 384 (48 × 8) dots can be driven. When 48 segments × 8 commons is selected, COM terminals change to SEG terminals as follows:
 COM16 → SEG40 COM15 → SEG41 COM14 → SEG42 COM13 → SEG43 COM12 → SEG44
 COM11 → SEG45 COM10 → SEG46 COM9 → SEG47 COM8 → SEG47
 This option is valid on the PRC board, however, the SEG47–SEG40 terminals are separately provided. Therefore, be aware that the COM8–COM16 terminals cannot be changed to the SEG47–SEG40.

Clock timer

Be sure to read timer data in the order of low-order data (TM0–TM3) then high-order data (TM4–TM7).

Stopwatch timer

When data of the counter is read at run mode, perform the reading after suspending the counter once and then set SWRUN to "1" again. Moreover, it is required that the suspension period not exceed 976 μsec (1/4 cycle of 256 Hz).

Programmable timer

- (1) When reading counter data, be sure to read the low-order 4 bits (PTD00–PTD03, PTD10–PTD13) first. Furthermore, the high-order 4 bits (PTD04–PTD07, PTD14–PTD17) should be read within 0.73 msec (when fOSC1 is 32.768 kHz) of reading the low-order 4 bits (PTD00–PTD03, PTD10–PTD13).

- (2) The programmable timer actually enters RUN/STOP status in synchronization with the falling edge of the input clock after writing to the PTRUN0/PTRUN1 register. Consequently, when "0" is written to the PTRUN0/PTRUN1 register, the timer enters STOP status at the point where the counter is decremented (-1). The PTRUN0/PTRUN1 register maintains "1" for reading until the timer actually stops.

Figure 5.2.1 shows the timing chart for the RUN/STOP control.

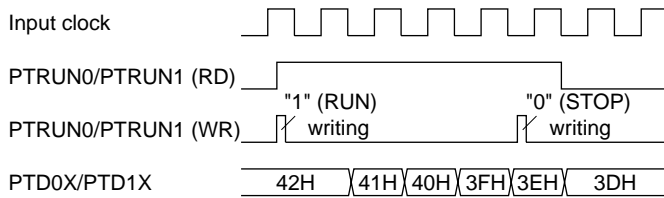

Fig. 5.2.1 Timing chart for RUN/STOP control

It is the same even in the event counter mode. Therefore, be aware that the counter does not enter RUN/STOP status if a clock is not input after setting the RUN/STOP control register (PTRUN0).

- (3) Since the TOUT signal is generated asynchronously from the PTOUT register, a hazard within 1/2 cycle is generated when the signal is turned ON and OFF by setting the register.
- (4) When the OSC3 oscillation clock is selected for the clock source, it is necessary to turn the OSC3 oscillation ON, prior to using the programmable timer. However the OSC3 oscillation circuit requires a time at least 5 msec from turning the circuit ON until the oscillation stabilizes. Therefore, allow an adequate interval from turning the OSC3 oscillation circuit ON to starting the programmable timer. Refer to Section 4.3, "Oscillation Circuit", for the control and notes of the OSC3 oscillation circuit. At initial reset, the OSC3 oscillation circuit is set in the OFF state.

Serial interface (1), (2)

- (1) Be sure to initialize the serial interface mode in the transmit/receive disabled status (TXEN = RXEN = "0").
- (2) Do not perform double trigger (writing "1") to TXTRG (RXTRG) when the serial interface is in the transmitting (receiving) operation.
- (3) In the clock synchronous mode, since one clock line (SCLK) is shared for both transmitting and receiving, transmitting and receiving cannot be performed simultaneously. (Half duplex only is possible in clock synchronous mode.) Consequently, be sure not to write "1" to RXTRG (TXTRG) when TXTRG (RXTRG) is "1".
- (4) When a parity error or framing error is generated during receiving in the asynchronous mode, the receiving error interrupt factor flag ISER is set to "1" prior to the receive completion interrupt factor flag ISRC for the time indicated in Table 4.11.10.1. Consequently, when an error is generated, you should reset the receiving complete interrupt factor flag ISRC to "0" by providing a wait time in error processing routines and similar routines. When an overrun error is generated, the receiving complete interrupt factor flag ISRC is not set to "1" and a receiving complete interrupt is not generated.

Table 5.2.1 Time difference between ISER and ISRC on error generation

Clock source	Time difference
fosc3 / n	1/2 cycles of fosc3 / n
Programmable timer	1 cycle of timer 1 underflow

- (5) When the demultiplied signal of the OSC3 oscillation circuit is made the clock source, it is necessary to turn the OSC3 oscillation ON, prior to using the serial interface. A time interval of 5 msec, from the turning ON of the OSC3 oscillation circuit to until the oscillation stabilizes, is necessary, due to the oscillation element that is used. Consequently, you should allow an adequate waiting time after turning ON of the OSC3 oscillation, before starting transmitting/receiving of serial interface.
- (6) Be aware that the maximum clock frequency for the serial interface is limited to 1 MHz.

Sound generator

- (1) Since the BZ and XBZ signals are generated asynchronous to the BZE register, hazards may be produced when the signal goes ON/OFF due to the setting of the BZE register.
- (2) The one-shot output is only valid when the normal buzzer output is OFF (BZE = "0") and will be invalid when the normal buzzer output is ON (BZE = "1").
- (3) Since the BZ and XBZ signals are the special outputs of the R01 and R00 ports, it is necessary to set the high impedance control registers (R01HIZ, R00HIZ) to "0", the data registers (R01, R00) to "1" and the output selection registers (BZOUT, XBZOUT) to "1" before setting the BZE register to "1".

SVD circuit

- (1) To obtain a stable detection result, the SVD circuit must be ON for at least 100 µsec. So, to obtain the SVD detection result, follow the programming sequence below.
 1. Set SVDON to "1"
 2. Maintain for 100 µsec minimum
 3. Set SVDON to "0"
 4. Read SVDDT
- (2) The SVD circuit should normally be turned OFF because SVD operation increase current consumption.

Telephone function

- (1) It is necessary to turn the OSC3 oscillation on prior to a dialing operation in tone mode because the tone mode uses the OSC3 (3.58 MHz) clock. However it increases current consumption. Therefore, turn the OSC3 oscillation off after finishing the dialling operation in tone mode.
- (2) Do not write "0" (0000B) to the IDP, FTS, PTS or TCD (in pulse mode) registers because it may cause a malfunction.
- (3) The pause function control bit PAUSE (FF14H•D1) and the flash function control bit FLASH (FF14H•D0) are write-only, so software cannot control these functions (on address FF14H) using an ALU instruction (AND, OR ...). Furthermore, be aware that the pause function or the flash function is canceled when "0" is written to the PAUSE bit (FF14H•D1) or the FLASH bit (FF14H•D0).

FSK demodulator

- (1) When starting the FSK demodulator operation, the OSC3 oscillation circuit must be turned ON and the CPU operating clock must be switched to the OSC3 clock.

The OSC3 oscillation circuit takes a maximum 5 msec for oscillation stabilization after turning the circuit ON. Consequently, allow an adequate waiting time after turning ON the OSC3 oscillation, before starting the FSK operation. Note that the oscillation start time will vary somewhat depending on the oscillator and on the externally attached parts.
- (2) In order to decrease current consumption, the FSK demodulator and the OSC3 oscillation circuit should be turned OFF when their operations are not necessary.
- (3) When detecting a carrier, the FSK demodulator may output invalid data at the rising edge of the CDET signal. In this case, the first byte received to the serial interface (2) may result in a parity error or a framing error. As this byte is generally used as a leader code, ignore the error in the processing.

Interrupt

- (1) The interrupt factor flags are set when the interrupt condition is established, even if the interrupt mask registers are set to "0".
- (2) After an interrupt occurs, the same interrupt will occur again if the interrupt enabled state (I flag = "1") is set or the RETI instruction is executed unless the interrupt factor flag is reset. Therefore, be sure to reset (write "1" to) the interrupt factor flag in the interrupt service routine before shifting to the interrupt enabled state.
- (3) After an initial reset, all the interrupts including NMI are masked until both the stack pointers SP1 and SP2 are set with the software. Be sure to set the SP1 and SP2 in the initialize routine.

Further, when re-setting the stack pointer, the SP1 and SP2 must be set as a pair. When one of them is set, all the interrupts including NMI are masked and interrupts cannot be accepted until the other one is set.

5.3 Precautions on Mounting

<Oscillation Circuit>

- Oscillation characteristics change depending on conditions (board pattern, components used, etc.). In particular, when a ceramic oscillator or crystal oscillator is used, use the oscillator manufacturer's recommended values for constants such as capacitance and resistance.
- Disturbances of the oscillation clock due to noise may cause a malfunction. Consider the following points to prevent this:

- (1) Components which are connected to the OSC1, OSC2, OSC3 and OSC4 terminals, such as oscillators, resistors and capacitors, should be connected in the shortest line.
- (2) As shown in the right hand figure, make a Vss pattern as large as possible at circumscription of the OSC1, OSC2, OSC3 and OSC4 terminals and the components connected to these terminals. Furthermore, do not use this Vss pattern for any purpose other than the oscillation system.

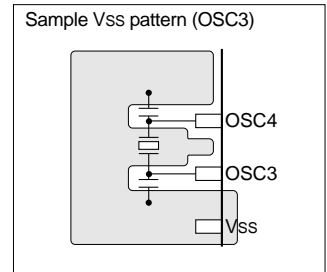

- In order to prevent unstable operation of the oscillation circuit due to current leak between OSC1/OSC3 and VDD, please keep enough distance between OSC1/OSC3 and VDD or other signals on the board pattern.

<Reset Circuit>

- The power-on reset signal which is input to the $\overline{\text{RESET}}$ terminal changes depending on conditions (power rise time, components used, board pattern, etc.). Decide the time constant of the capacitor and resistor after enough tests have been completed with the application product. When the built-in pull-up resistor is added to the $\overline{\text{RESET}}$ terminal by mask option, take into consideration dispersion of the resistance for setting the constant.
- In order to prevent any occurrences of unnecessary resetting caused by noise during operating, components such as capacitors and resistors should be connected to the $\overline{\text{RESET}}$ terminal in the shortest line.

<Power Supply Circuit>

- Sudden power supply variation due to noise may cause malfunction. Consider the following points to prevent this:
 - (1) The power supply should be connected to the VDD and Vss terminals with patterns as short and large as possible.
 - (2) When connecting between the VDD and Vss terminals with a bypass capacitor, the terminals should be connected as short as possible.

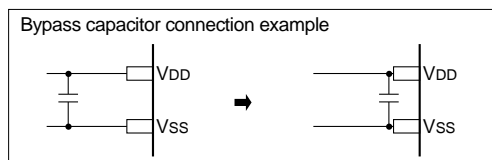

- (3) Components which are connected to the VD1 and VC1-VC5 terminals, such as capacitors, should be connected in the shortest line. In particular, the VC1-VC5 voltages affect the display quality.
- Do not connect anything to the VC1-VC5 terminals when the LCD driver is not used.

<Arrangement of Signal Lines>

- In order to prevent generation of electromagnetic induction noise caused by mutual inductance, do not arrange a large current signal line near the circuits that are sensitive to noise such as the oscillation unit.
- When a signal line is parallel with a high-speed line in long distance or intersects a high-speed line, noise may generated by mutual interference between the signals and it may cause a malfunction. Do not arrange a high-speed signal line especially near circuits that are sensitive to noise such as the oscillation unit.

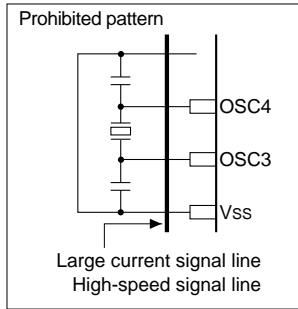

<Precautions for Visible Radiation (when bare chip is mounted)>

- Visible radiation causes semiconductor devices to change the electrical characteristics. It may cause this IC to malfunction. When developing products which use this IC, consider the following precautions to prevent malfunctions caused by visible radiations.
 - (1) Design the product and implement the IC on the board so that it is shielded from visible radiation in actual use.
 - (2) The inspection process of the product needs an environment that shields the IC from visible radiation.
 - (3) As well as the face of the IC, shield the back and side too.

CHAPTER 6 BASIC EXTERNAL WIRING DIAGRAM

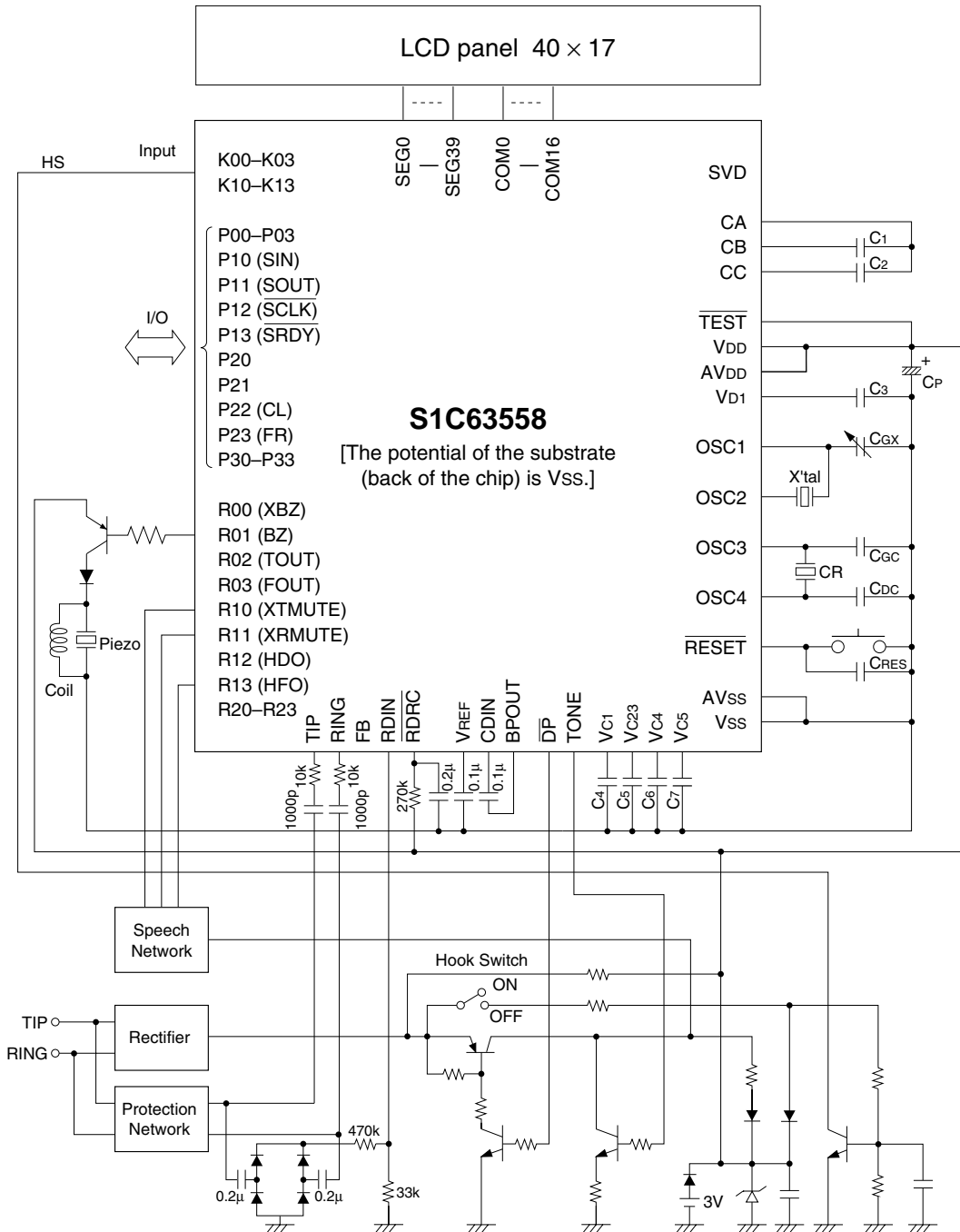

X'tal	Crystal oscillator	32.768 kHz, C1 (Max.) = 34 kΩ
CGX	Trimmer capacitor	5–25 pF
CR	Ceramic oscillator	3.58 MHz
CGC	Gate capacitor	30 pF
CDC	Drain capacitor	30 pF
C1–C7	Capacitor	0.2 μF
CP	Capacitor	10 μF
CRES	RESET terminal capacitor	0.1 μF

Note: The table is simply an example, and is not guaranteed to work.

CHAPTER 7 ELECTRICAL CHARACTERISTICS

7.1 Absolute Maximum Rating

(V _{SS} =0V)			
Item	Symbol	Rated value	Unit
Supply voltage	V _{DD}	-0.5 to 7.0	V
Input voltage (1)	V _I	-0.5 to V _{DD} + 0.3	V
Input voltage (2)	V _I OSC	-0.5 to V _{D1} + 0.3	V
Permissible total output current *1	ΣI _{VDD}	10	mA
Operating temperature	T _{opr}	-20 to 70	°C
Storage temperature	T _{stg}	-65 to 150	°C
Soldering temperature / time	T _{sol}	260°C, 10sec (lead section)	–
Permissible dissipation *2	P _D	250	mW

*1 The permissible total output current is the sum total of the current (average current) that simultaneously flows from the output pin (or is drawn in).

*2 In case of plastic package (QFP15-128pin).

7.2 Recommended Operating Conditions

(T _a =-20 to 70°C)							
Item	Symbol	Condition	Min.	Typ.	Max.	Unit	
Supply voltage	V _{DD}	V _{SS} =0V	OSC3 oscillation OFF	2.2		5.5	V
			OSC3 oscillation ON	2.2		5.5	V
			When DTMF is used	2.5		5.5	V
			When FSK is used	2.5		5.5	V
Oscillation frequency	f _{OSC1}	Crystal oscillation	–	32.768	–	kHz	
	f _{OSC3}	Ceramic oscillation	–	3.58	3.6	MHz	
SVD terminal input voltage	SVD	SVD ≤ V _{DD} , V _{SS} =0V	0		5.5	V	

7.3 DC Characteristics

Unless otherwise specified:

$V_{DD}=3.0V$, $V_{SS}=0V$, $f_{OSC1}=32.768kHz$, $T_a=-20$ to $70^{\circ}C$, $V_{D1}/V_{C1}/V_{C23}/V_{C4}/V_{C5}$ are internal voltage, $C_1-C_7=0.2\mu F$

Item	Symbol	Condition	Min.	Typ.	Max.	Unit
High level input voltage (1)	V_{IH1}	K00-03, K10-13 P00-03, P10-13, P20-23, P30-33	$0.8 \cdot V_{DD}$		V_{DD}	V
High level input voltage (2)	V_{IH2}	RESET, TEST	$0.9 \cdot V_{DD}$		V_{DD}	V
High level input voltage (3)	V_{IH3}	RDIN, RDRC	$0.75 \cdot V_{DD}$		V_{DD}	V
Low level input voltage (1)	V_{IL1}	K00-03, K10-13	0		$0.2 \cdot V_{DD}$	V
Low level input voltage (2)	V_{IL2}	P00-03, P10-13, P20-23, P30-33	0		0.4	V
Low level input voltage (3)	V_{IL3}	RESET, TEST	0		$0.1 \cdot V_{DD}$	V
Low level input voltage (4)	V_{IL4}	RDIN, RDRC	0		$0.25 \cdot V_{DD}$	V
High level input current	I_{IH}	$V_{IH}=3.0V$ K00-03, K10-13, RDIN, RDRC P00-03, P10-13, P20-23, P30-33 RESET, TEST, SVD	0		0.5	μA
Low level input current (1)	I_{IL1}	$V_{IL1}=V_{SS}$ No Pull-up K00-03, K10-13, RDIN, RDRC P00-03, P10-13, P20-23, P30-33 RESET, TEST, SVD	-0.5		0	μA
Low level input current (2)	I_{IL2}	$V_{IL2}=V_{SS}$ With Pull-up K00-03, K10-13 P00-03, P10-13, P20-23, P30-33 RESET, TEST	-16	-10	-6	μA
High level output current	I_{OH1}	$V_{OH1}=0.9 \cdot V_{DD}$ R00-03, R10-13, R20-23 P00-03, P10-13, P20-23, P30-33			-1	mA
Low level output current	I_{OL1}	$V_{OL1}=0.1 \cdot V_{DD}$ R00-03, R10-13, R20-23, RDRC P00-03, P10-13, P20-23, P30-33	3			mA
Common output current	I_{OH2}	$V_{OH2}=V_{C5}-0.05V$ COM0-16			-25	μA
	I_{OL2}	$V_{OL2}=V_{SS}+0.05V$	25			μA
Segment output current	I_{OH3}	$V_{OH3}=V_{C5}-0.05V$ SEG0-39			-10	μA
	I_{OL3}	$V_{OL3}=V_{SS}+0.05V$	10			μA

Unless otherwise specified:

$V_{DD}=5.0V$, $V_{SS}=0V$, $f_{OSC1}=32.768kHz$, $T_a=-20$ to $70^{\circ}C$, $V_{D1}/V_{C1}/V_{C23}/V_{C4}/V_{C5}$ are internal voltage, $C_1-C_7=0.2\mu F$

Item	Symbol	Condition	Min.	Typ.	Max.	Unit
High level input voltage (1)	V_{IH1}	K00-03, K10-13 P00-03, P10-13, P20-23, P30-33	$0.8 \cdot V_{DD}$		V_{DD}	V
High level input voltage (2)	V_{IH2}	RESET, TEST	$0.9 \cdot V_{DD}$		V_{DD}	V
High level input voltage (3)	V_{IH3}	RDIN, RDRC	$0.75 \cdot V_{DD}$		V_{DD}	V
Low level input voltage (1)	V_{IL1}	K00-03, K10-13	0		$0.2 \cdot V_{DD}$	V
Low level input voltage (2)	V_{IL2}	P00-03, P10-13, P20-23, P30-33	0		0.4	V
Low level input voltage (3)	V_{IL3}	RESET, TEST	0		$0.1 \cdot V_{DD}$	V
Low level input voltage (4)	V_{IL4}	RDIN, RDRC	0		$0.25 \cdot V_{DD}$	V
High level input current	I_{IH}	$V_{IH}=5.0V$ K00-03, K10-13, RDIN, RDRC P00-03, P10-13, P20-23, P30-33 RESET, TEST, SVD	0		0.5	μA
Low level input current (1)	I_{IL1}	$V_{IL1}=V_{SS}$ No Pull-up K00-03, K10-13, RDIN, RDRC P00-03, P10-13, P20-23, P30-33 RESET, TEST, SVD	-0.5		0	μA
Low level input current (2)	I_{IL2}	$V_{IL2}=V_{SS}$ With Pull-up K00-03, K10-13 P00-03, P10-13, P20-23, P30-33 RESET, TEST	-25	-15	-10	μA
High level output current	I_{OH1}	$V_{OH1}=0.9 \cdot V_{DD}$ R00-03, R10-13, R20-23 P00-03, P10-13, P20-23, P30-33			-3	mA
Low level output current	I_{OL1}	$V_{OL1}=0.1 \cdot V_{DD}$ R00-03, R10-13, R20-23, RDRC P00-03, P10-13, P20-23, P30-33	7.5			mA
Common output current	I_{OH2}	$V_{OH2}=V_{C5}-0.05V$ COM0-16			-25	μA
	I_{OL2}	$V_{OL2}=V_{SS}+0.05V$	25			μA
Segment output current	I_{OH3}	$V_{OH3}=V_{C5}-0.05V$ SEG0-39			-10	μA
	I_{OL3}	$V_{OL3}=V_{SS}+0.05V$	10			μA

7.4 Analog Circuit Characteristics and Power Current Consumption

Unless otherwise specified:

$V_{DD}=3.0V$, $V_{SS}=0V$, $f_{osc1}=32.768kHz$, $C_G=25pF$, $T_a=-20$ to $70^{\circ}C$, $V_{D1}/V_{C1}/V_{C23}/V_{C4}/V_{C5}$ are internal voltage, $C_1-C_7=0.2\mu F$

Item	Symbol	Condition	Min.	Typ.	Max.	Unit	
LCD drive voltage	Vc1	Connect 1 MΩ load resistor between Vss and Vc1 (without panel load)	1/2·Vc23 ×0.95		1/2·Vc23 -0.1	V	
		Vc23	Connect 1 MΩ load resistor between Vss and Vc23 (without panel load)	LC0-3="0"	1.95	Typ. ×0.88	Typ. ×1.12
	LC0-3="1"			1.98			
	LC0-3="2"			2.01			
	LC0-3="3"			2.04			
	LC0-3="4"			2.07			
	LC0-3="5"			2.10			
	LC0-3="6"			2.13			
	LC0-3="7"			2.16			
	LC0-3="8"			2.19			
	LC0-3="9"			2.22			
	LC0-3="10"			2.25			
	LC0-3="11"			2.28			
	LC0-3="12"			2.31			
	LC0-3="13"	2.34					
LC0-3="14"	2.37						
LC0-3="15"	2.40						
	Vc4	Connect 1 MΩ load resistor between Vss and Vc4 (without panel load)	3/2·Vc23 ×0.95		3/2·Vc23	V	
	Vc5	Connect 1 MΩ load resistor between Vss and Vc5 (without panel load)	2·Vc23 ×0.95		2·Vc23	V	
SVD voltage ($T_a=25^{\circ}C$)	VsVD1	SVDS0-3="0" (internal)		2.20	Typ. ×1.07	V	
		SVDS0-3="1"	2.20				
		SVDS0-3="2"	2.20				
		SVDS0-3="3"	2.20				
		SVDS0-3="4"	2.20				
		SVDS0-3="5"	2.30				
		SVDS0-3="6"	2.40				
		SVDS0-3="7"	2.50				
		SVDS0-3="8"	2.60				
		SVDS0-3="9"	2.70				
		SVDS0-3="10"	2.80				
		SVDS0-3="11"	2.90				
		SVDS0-3="12"	3.00				
		SVDS0-3="13"	3.10				
		SVDS0-3="14"	3.20				
SVDS0-3="15"	3.30						
SVD voltage (external) *3	VsVD2	SVDS0-3="0" (external), $T_a = 25^{\circ}C$	0.85	0.95	1.05	V	
SVD circuit response time	t _{sVD}	$T_a = 25^{\circ}C$			100	μs	
Current consumption ($T_a=25^{\circ}C$)	IOP	During HALT (32 kHz crystal oscillation)	LCD power OFF *1, *2	1.5	3	μA	
			LCD power ON *1, *2	4	8	μA	
		During execution (32 kHz crystal oscillation)	LCD power ON *1, *2	10	19	μA	
			LCD power ON *1	150	300	μA	
		During HALT (3.58 MHz ceramic oscillation)	LCD power ON *1	600	800	μA	
			LCD power ON *1				
		SVD circuit current (during supply voltage detection) $V_{DD}=2.2$ to 5.5 V		1		15	μA
		SVD circuit current (during external voltage detection) $V_{DD}=2.2$ to 5.5 V		0.5		6	μA
		DTMF circuit current $V_{DD}=5.5$ V *4			1.4	2.5	mA
		DTMF circuit current $V_{DD}=3.0$ V *4			1.2	2.0	mA
FSK circuit current $V_{DD}=5.5$ V *4			1.8	2.5	mA		
FSK circuit current $V_{DD}=3.0$ V *4			1.0	1.5	mA		

*1 Without panel load. The SVD circuit is OFF.

*2 OSCC = "0"

*3 Please input the voltage, which is within the range between Vss and VDD, into the SVD terminal.

*4 OSC3 oscillation current and CPU operating current with a 3.58 MHz clock are included.

7.5 Oscillation Characteristics

The oscillation characteristics change depending on the conditions (components used, board pattern, etc.). Use the following characteristics as reference values.

OSC1 crystal oscillation circuit

Unless otherwise specified:

$V_{DD}=3.0V$, $V_{SS}=0V$, $f_{OSC1}=32.768kHz$, $C_G=25pF$, $C_D=$ built-in, $T_a=-20$ to $70^{\circ}C$

Item	Symbol	Condition	Min.	Typ.	Max.	Unit
Oscillation start voltage	V_{sta}	$t_{sta} \leq 3sec (V_{DD})$	2.2			V
Oscillation stop voltage	V_{stp}	$t_{stp} \leq 10sec (V_{DD})$	2.2			V
Built-in capacitance (drain)	C_D	Including the parasitic capacitance inside the IC (in chip)		14		pF
Frequency/voltage deviation	$\Delta f/\Delta V$	$V_{DD}=2.2$ to $5.5V$			10	ppm
Frequency/IC deviation	$\Delta f/\Delta IC$		-10		10	ppm
Frequency adjustment range	$\Delta f/\Delta C_G$	$C_G=5$ to $25pF$	10	20		ppm
Harmonic oscillation start voltage	V_{hho}	$C_G=5pF (V_{DD})$	5.5			V
Permitted leak resistance	R_{leak}	Between OSC1 and V_{SS}	200			$M\Omega$

OSC3 ceramic oscillation circuit

Unless otherwise specified:

$V_{DD}=3.0V$, $V_{SS}=0V$, Ceramic oscillator: $3.58MHz$, $C_{GC}=C_{DC}=30pF$, $T_a=-20$ to $70^{\circ}C$

Item	Symbol	Condition	Min.	Typ.	Max.	Unit
Oscillation start voltage	V_{sta}	(V_{DD})	2.2			V
Oscillation start time	t_{sta}	$V_{DD}=2.2$ to $5.5V$			5	ms
Oscillation stop voltage	V_{stp}	(V_{DD})	2.2			V

7.6 Serial Interface (1), (2) AC Characteristics

1. Clock synchronous master mode (during 1 MHz operation)

Condition: $V_{DD}=3.0V$, $V_{SS}=0V$, $T_a=-20$ to $70^{\circ}C$, $V_{IH1}=0.8V_{DD}$, $V_{IL1}=0.2V_{DD}$, $V_{OH}=0.8V_{DD}$, $V_{OL}=0.2V_{DD}$

Item	Symbol	Min.	Typ.	Max.	Unit
Transmitting data output delay time	t_{smd}			200	ns
Receiving data input set-up time	t_{sms}	400			ns
Receiving data input hold time	t_{smh}	200			ns

Note that the maximum clock frequency is limited to 1 MHz.

2. Clock synchronous slave mode (during 1 MHz operation)

Condition: $V_{DD}=3.0V$, $V_{SS}=0V$, $T_a=-20$ to $70^{\circ}C$, $V_{IH1}=0.8V_{DD}$, $V_{IL1}=0.2V_{DD}$, $V_{OH}=0.8V_{DD}$, $V_{OL}=0.2V_{DD}$

Item	Symbol	Min.	Typ.	Max.	Unit
Transmitting data output delay time	t_{ssd}			500	ns
Receiving data input set-up time	t_{sss}	400			ns
Receiving data input hold time	t_{ssh}	200			ns

Note that the maximum clock frequency is limited to 1 MHz.

<Master mode>

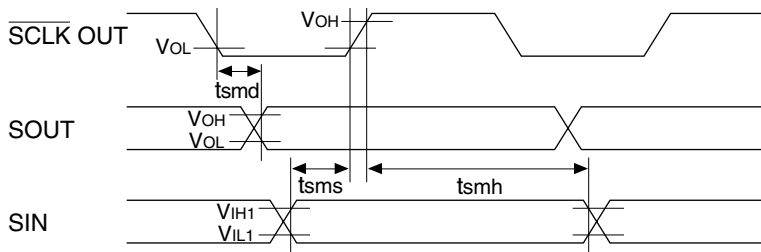

<Slave mode>

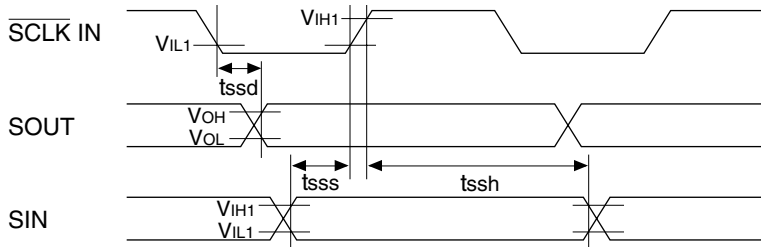

3. Asynchronous system

Condition: $V_{DD}=2.2$ to $5.5V$, $V_{SS}=0V$, $T_a=-20$ to $70^{\circ}C$

Item	Symbol	Min.	Typ.	Max.	Unit
Start bit detection error time *1	t_{sa1}	0		$t/16$	s
Erroneous start bit detection range time *2	t_{sa2}	$9t/16$		$10t/16$	s

*1 Start bit detection error time is a logical delay time from inputting the start bit until internal sampling begins operating. (Time as far as AC is excluded.)

*2 Erroneous start bit detection range time is a logical range to detect whether a LOW level (start bit) has been input again after a start bit has been detected and the internal sampling clock has started. When a HIGH level is detected, the start bit detection circuit is reset and goes into a wait status until the next start bit. (Time as far as AC is excluded.)

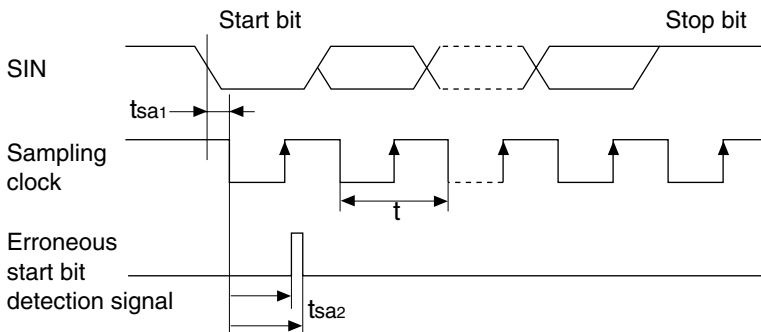

7.7 FSK Demodulator Characteristics

Unless otherwise specified:

$V_{DD}=5.0V$, $V_{SS}=0V$, $f_{CLK}=3.579545MHz$, $T_a=-20$ to $70^{\circ}C$

Item	Symbol	Condition	Min.	Typ.	Max.	Unit
Transfer rate	TRATE		1188	1200	1212	Baud
Bell202 mark (logic 1) frequency	fb1		1188	1200	1212	Hz
Bell202 space (logic 0) frequency	fb0		2178	2200	2222	Hz
ITU-T V.23 mark (logic 1) frequency	fv1		1280	1300	1320	Hz
ITU-T V.23 space (logic 0) frequency	fv0		2068	2100	2132	Hz
Signal-to-noise ratio	SNR		20	–	–	dB
Band-pass filter gain *1	GBPF	300Hz	–	9.2	–	dB
		1200Hz	–	42.7	–	dB
		1700Hz	–	42.8	–	dB
		2200Hz	–	42.7	–	dB
		3000Hz	–	22.4	–	dB
		4000Hz	–	3.7	–	dB
		$\geq 10000Hz$	–	-20.0	–	dB
Carrier detection ON sensitivity *2	CDON	$V_{DD}=5.0V$	–	-51	-48	dBm
Carrier detection OFF sensitivity *2	CDOFF	$V_{DD}=5.0V$	-57	-54	–	dBm
Input clock frequency	fCLK		-0.1%	3.579545	+0.1%	MHz
Input AC impedance	RIN	$V_{DD}=5.0V$ (between TIP/RING pin and VREF)	70	100	130	k Ω
FSKON set-up time	tSUP		20	–	–	ms
Carrier detection response time	tCDON		3	6.25	9	ms
	tCDOFF		5	7.5	10	ms

*1 Value measured between TIP/RING pin and BPOUT pin

*2 The following expressions can be used to calculate the typical values (dBm) of CDON and CDOFF when an external resistor RTR (10k Ω Typ.) is connected in series with the TIP pin and the RING pin.

$$CDON = -51 + 20\log\left(\frac{V_{DD}}{5} \times \frac{100k}{R_{TR} + 100k}\right) \text{ [dBm]} \quad CDOFF = -54 + 20\log\left(\frac{V_{DD}}{5} \times \frac{100k}{R_{TR} + 100k}\right) \text{ [dBm]}$$

In addition, the following expressions can be used to calculate the sensitivity of CDON and CDOFF when an external feedback resistor is used for the input amplifier (mask option).

$$G_{Amp} = \frac{R_5}{R_1} = \frac{R_6}{R_2} \quad (R_1 = R_2, R_3 = R_4, R_5 = R_6, \text{ see Figure 4.15.2.2.})$$

$$CDON = -51 + 20\log\left(\frac{V_{DD}}{5} \times \frac{R_1}{R_5}\right) \text{ [dBm]} \quad CDOFF = -54 + 20\log\left(\frac{V_{DD}}{5} \times \frac{R_1}{R_5}\right) \text{ [dBm]}$$

Band-pass filter gain (Typ. value)

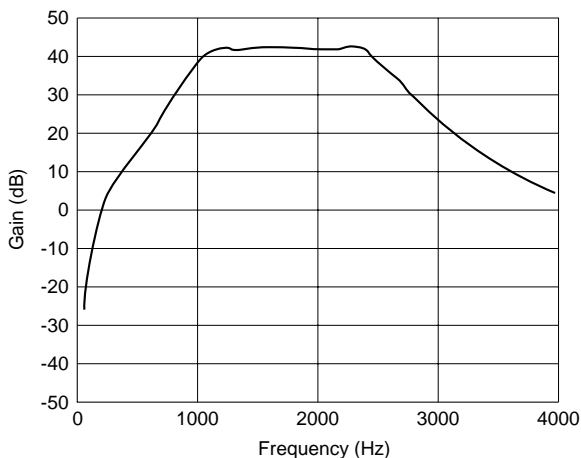

Timing chart

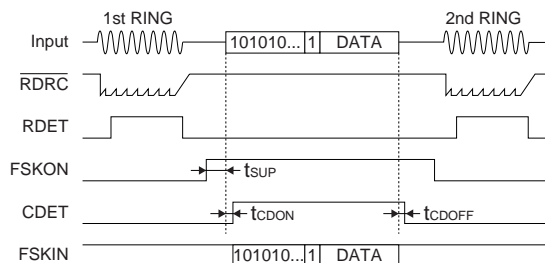

7.8 Telephone Function Characteristics

Unless otherwise specified:

VDD=3.0V, VSS=0V, fCLK=3.579545MHz, Ta=-20 to 70°C

Item	Symbol	Condition	Min.	Typ.	Max.	Unit
Flash pause time	tFLP		–	938	–	ms
Mute hold time	tMH		–	4	–	ms
Make ratio	M/B	Selected by software	–	1/2 2/3	–	–
Dial puls rate	DR	Selected by software	–	10 20	–	pps
Make time	tm	10pps, M/B=1/2	–	33.2	–	ms
		20pps, M/B=1/2	–	16.6	–	ms
		10pps, M/B=2/3	–	39.1	–	ms
		20pps, M/B=2/3	–	19.5	–	ms
Break time	tb	10pps, M/B=1/2	–	66.4	–	ms
		20pps, M/B=1/2	–	33.2	–	ms
		10pps, M/B=2/3	–	58.6	–	ms
		20pps, M/B=2/3	–	29.3	–	ms
Tone output DC level	VTDC		–	0.5(VDD-VSS)	–	V
ROW single tone output voltage	VR	VDD=3V, RL=10kΩ	–	92	–	mVrms
		VDD=5.5V, RL=10kΩ	–	168	–	mVrms
COL single tone output voltage	VC	VDD=3V, RL=10kΩ	–	122	–	mVrms
		VDD=5.5V, RL=10kΩ	–	224	–	mVrms
Tone output voltage ratio	dBCR	VDD=3V, RL=10kΩ	–	2.5	–	dB
		VDD=5.5V, RL=10kΩ	–	2.5	–	dB
Tone load resistor	RTL	VDD=2.5 to 5.5V	7	–	–	kΩ
Tone distortion ratio	THD	VDD=2.5 to 5.5V, RL=10kΩ	–	–	6	%
Tone output frequency	fROW1		–	701.32	–	Hz
	fROW2		–	771.45	–	Hz
	fROW3		–	857.17	–	Hz
	fROW4		–	935.10	–	Hz
	fCOL1		–	1215.88	–	Hz
	fCOL2		–	1331.68	–	Hz
	fCOL3		–	1471.85	–	Hz
	fCOL4		–	1645.01	–	Hz
Tone output time	tTD		94	–	–	ms
Tone inter-digit pause time	tTIP		–	94	–	ms
Tone output cycle	tT	tTD+tTIP	188	–	–	ms

7.9 Timing Chart

System clock switching

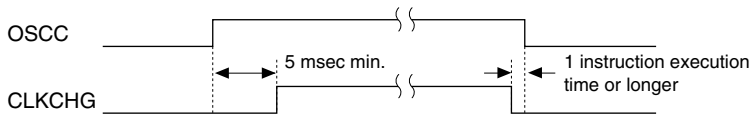

7.10 Characteristic Curves (reference value)

High level output current (Pxx, Rxx, BZ)

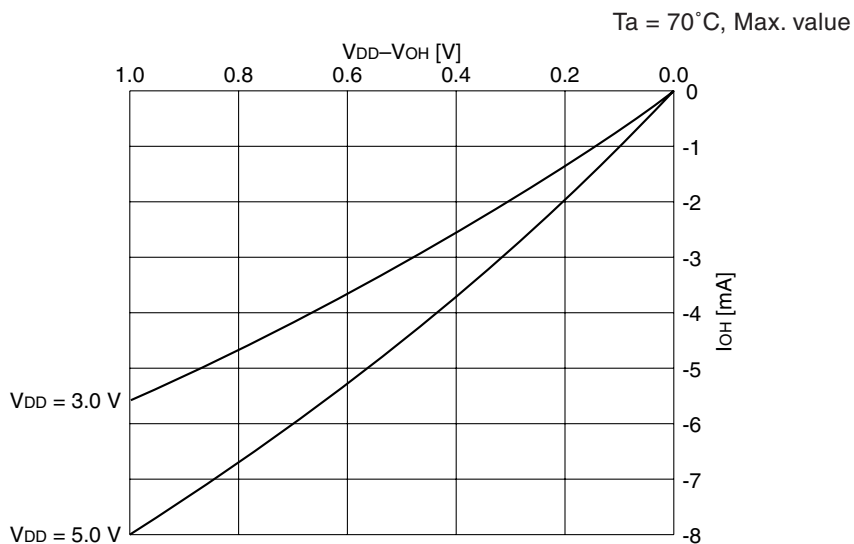

Low level output current (Pxx, Rxx, BZ)

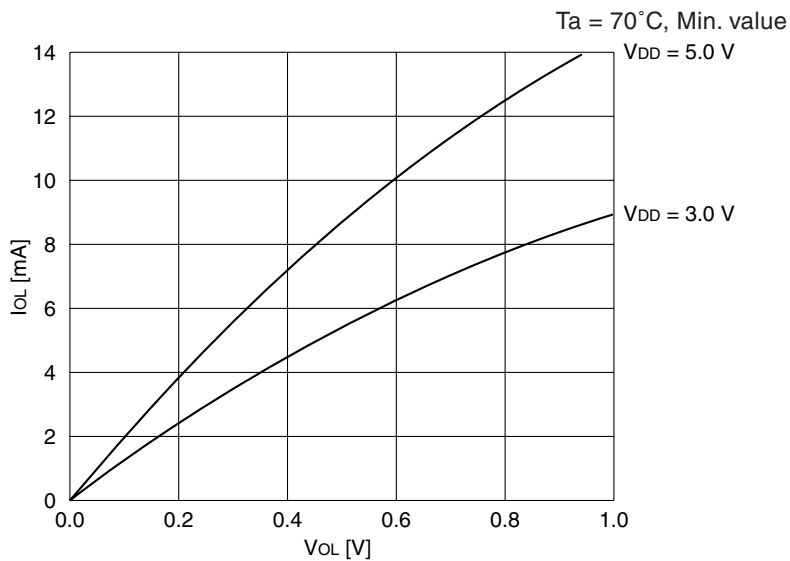

High level output current (SEGxx)

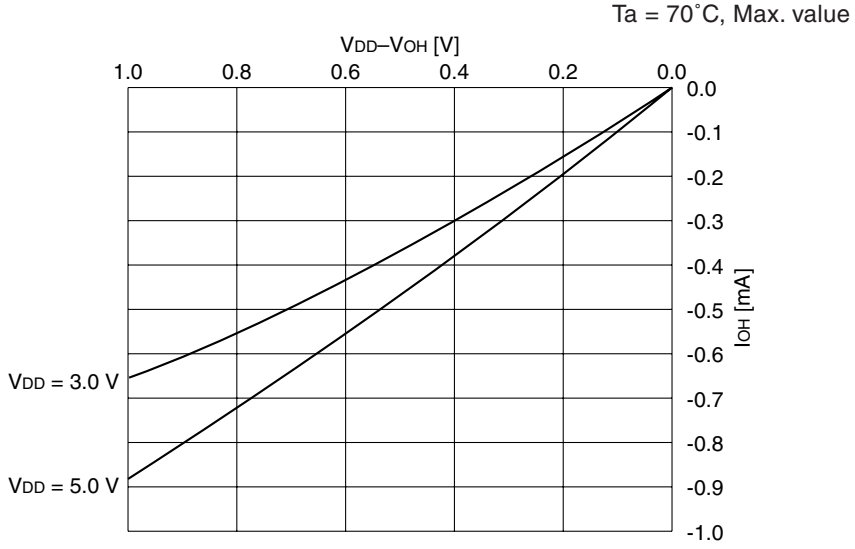

Low level output current (SEGxx)

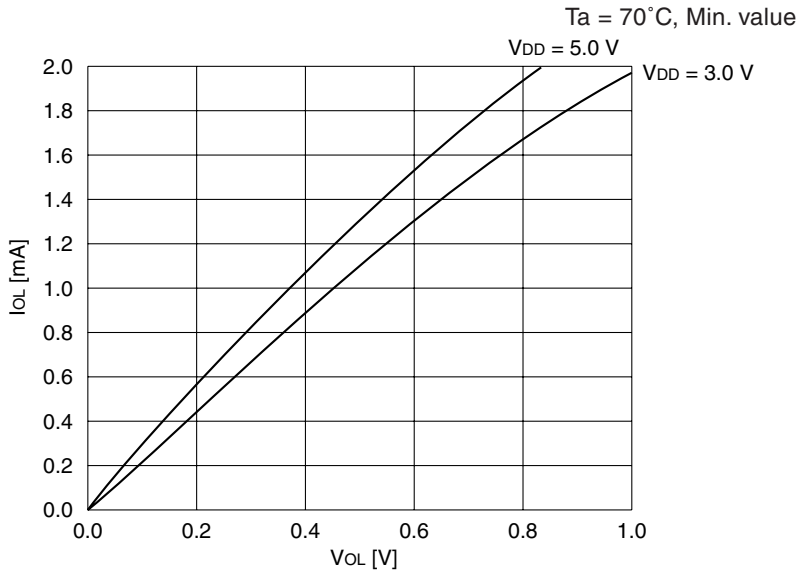

CHAPTER 8 PACKAGE

8.1 Plastic Package

QFP15-128pin

(Unit: mm)

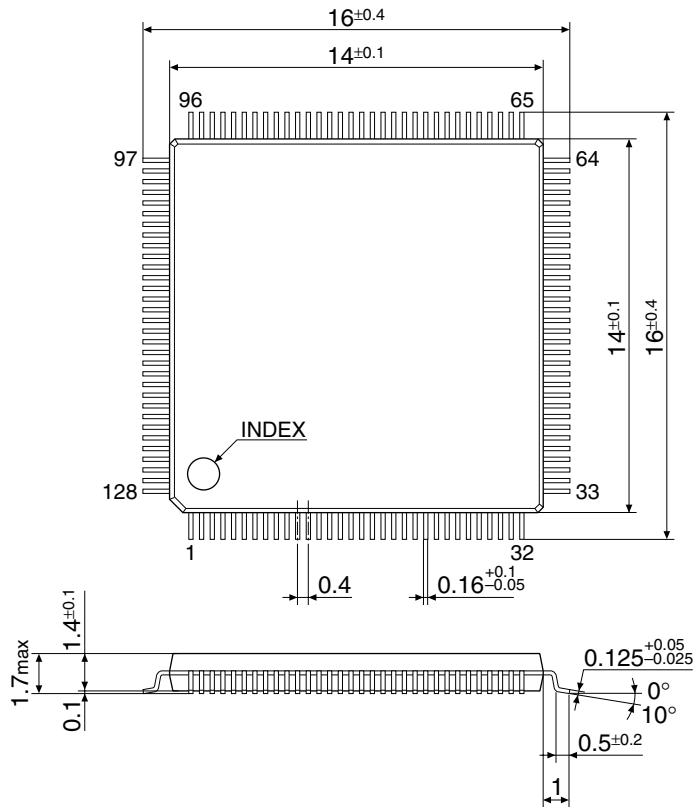

The dimensions are subject to change without notice.

8.2 Ceramic Package for Test Samples

(Unit: mm)

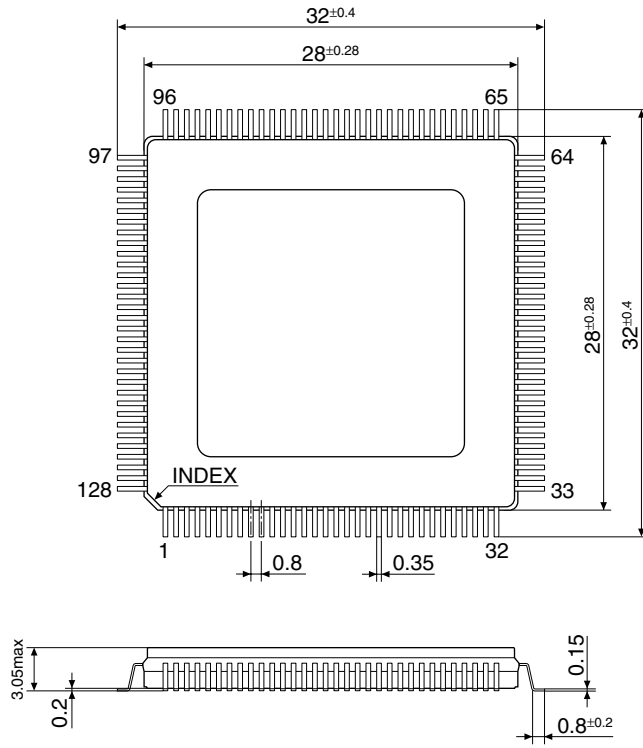

CHAPTER 9 PAD LAYOUT

9.1 Diagram of Pad Layout

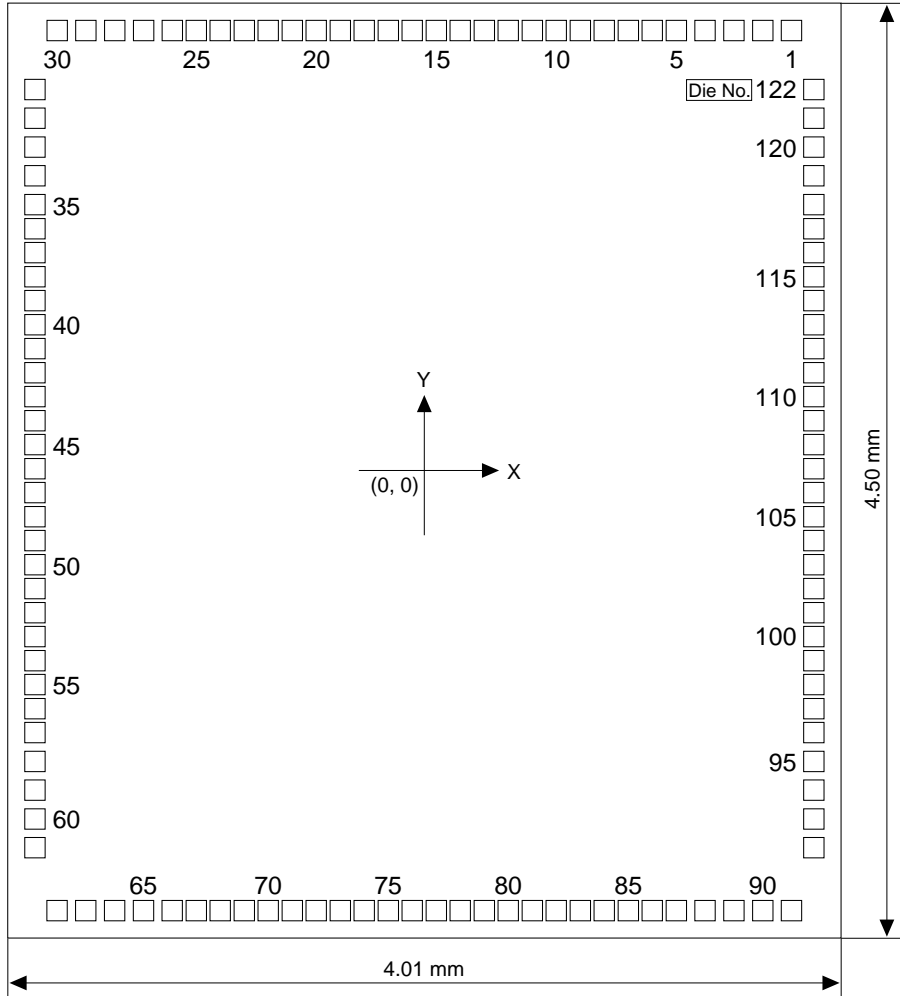

Chip thickness: 400 μm
 Pad opening: 100 μm

9.2 Pad Coordinates

Unit: μm

No.	Pad name	X	Y	No.	Pad name	X	Y	No.	Pad name	X	Y	No.	Pad name	X	Y
1	R10	1767	2118	31	P00	-1874	1834	62	SEG34	-1767	-2118	92	SEG4	1874	-1815
2	R03	1629	2118	32	K13	-1874	1696	63	SEG33	-1629	-2118	93	SEG3	1874	-1677
3	R02	1490	2118	33	K12	-1874	1557	64	SEG32	-1490	-2118	94	SEG2	1874	-1538
4	R01	1351	2118	34	K11	-1874	1419	65	SEG31	-1351	-2118	95	SEG1	1874	-1400
5	R00	1213	2118	35	K10	-1874	1280	66	SEG30	-1213	-2118	96	SEG0	1874	-1261
6	CDIN	1097	2118	36	K03	-1874	1164	67	SEG29	-1097	-2118	97	COM7	1874	-1146
7	BPOUT	982	2118	37	K02	-1874	1049	68	SEG28	-982	-2118	98	COM6	1874	-1030
8	RDR $\overline{\text{C}}$	866	2118	38	K01	-1874	933	69	SEG27	-866	-2118	99	COM5	1874	-915
9	RDIN	751	2118	39	K00	-1874	818	70	SEG26	-751	-2118	100	COM4	1874	-799
10	VREF	635	2118	40	SVD	-1874	702	71	SEG25	-635	-2118	101	COM3	1874	-684
11	AVSS	520	2118	41	Vc1	-1874	587	72	SEG24	-520	-2118	102	COM2	1874	-568
12	FB	404	2118	42	Vc23	-1874	471	73	SEG23	-404	-2118	103	COM1	1874	-453
13	RING	289	2118	43	Vc4	-1874	356	74	SEG22	-289	-2118	104	COM0	1874	-337
14	TIP	173	2118	44	Vc5	-1874	240	75	SEG21	-173	-2118	105	Vss	1874	-222
15	AVDD	58	2118	45	CC	-1874	125	76	SEG20	-58	-2118	106	OSC1	1874	-106
16	P33	-58	2118	46	CB	-1874	9	77	SEG19	58	-2118	107	OSC2	1874	9
17	P32	-173	2118	47	CA	-1874	-106	78	SEG18	173	-2118	108	Vd1	1874	125
18	P31	-289	2118	48	COM8/SEG47 *1	-1874	-222	79	SEG17	289	-2118	109	OSC3	1874	240
19	P30	-404	2118	49	COM9/SEG47 *1	-1874	-337	80	SEG16	404	-2118	110	OSC4	1874	356
20	P23	-520	2118	50	COM10/SEG46 *1	-1874	-453	81	SEG15	520	-2118	111	VDD	1874	471
21	P22	-635	2118	51	COM11/SEG45 *1	-1874	-568	82	SEG14	635	-2118	112	RESET	1874	587
22	P21	-751	2118	52	COM12/SEG44 *1	-1874	-684	83	SEG13	751	-2118	113	TEST	1874	702
23	P20	-866	2118	53	COM13/SEG43 *1	-1874	-799	84	SEG12	866	-2118	114	TONE	1874	818
24	P13	-982	2118	54	COM14/SEG42 *1	-1874	-915	85	SEG11	982	-2118	115	DP	1874	933
25	P12	-1097	2118	55	COM15/SEG41 *1	-1874	-1030	86	SEG10	1097	-2118	116	R23	1874	1049
26	P11	-1213	2118	56	COM16/SEG40 *1	-1874	-1146	87	SEG9	1213	-2118	117	R22	1874	1164
27	P10	-1351	2118	57	SEG39	-1874	-1261	88	SEG8	1351	-2118	118	R21	1874	1280
28	P03	-1490	2118	58	SEG38	-1874	-1400	89	SEG7	1490	-2118	119	R20	1874	1419
29	P02	-1629	2118	59	SEG37	-1874	-1538	90	SEG6	1629	-2118	120	R13	1874	1557
30	P01	-1767	2118	60	SEG36	-1874	-1677	91	SEG5	1767	-2118	121	R12	1874	1696
-				61	SEG35	-1874	-1815	-				122	R11	1874	1834

*1: Mask option

EPSON International Sales Operations

AMERICA

EPSON ELECTRONICS AMERICA, INC.

- HEADQUARTERS -

150 River Oaks Parkway
San Jose, CA 95134, U.S.A.
Phone: +1-408-922-0200 Fax: +1-408-922-0238

- SALES OFFICES -

West

1960 E. Grand Avenue
El Segundo, CA 90245, U.S.A.
Phone: +1-310-955-5300 Fax: +1-310-955-5400

Central

101 Virginia Street, Suite 290
Crystal Lake, IL 60014, U.S.A.
Phone: +1-815-455-7630 Fax: +1-815-455-7633

Northeast

301 Edgewater Place, Suite 120
Wakefield, MA 01880, U.S.A.
Phone: +1-781-246-3600 Fax: +1-781-246-5443

Southeast

3010 Royal Blvd. South, Suite 170
Alpharetta, GA 30005, U.S.A.
Phone: +1-877-EEA-0020 Fax: +1-770-777-2637

EUROPE

EPSON EUROPE ELECTRONICS GmbH

- HEADQUARTERS -

Riesstrasse 15
80992 Munich, GERMANY
Phone: +49-(0)89-14005-0 Fax: +49-(0)89-14005-110

SALES OFFICE

Altstadtstrasse 176
51379 Leverkusen, GERMANY
Phone: +49-(0)2171-5045-0 Fax: +49-(0)2171-5045-10

UK BRANCH OFFICE

Unit 2.4, Doncastle House, Doncastle Road
Bracknell, Berkshire RG12 8PE, ENGLAND
Phone: +44-(0)1344-381700 Fax: +44-(0)1344-381701

FRENCH BRANCH OFFICE

1 Avenue de l'Atlantique, LP 915 Les Conquerants
Z.A. de Courtaboeuf 2, F-91976 Les Ulis Cedex, FRANCE
Phone: +33-(0)1-64862350 Fax: +33-(0)1-64862355

BARCELONA BRANCH OFFICE

Barcelona Design Center
Edificio Testa, Avda. Alcalde Barrils num. 64-68
E-08190 Sant Cugat del Vallès, SPAIN
Phone: +34-93-544-2490 Fax: +34-93-544-2491

ASIA

EPSON (CHINA) CO., LTD.

23F, Beijing Silver Tower 2# North RD DongSanHuan
ChaoYang District, Beijing, CHINA
Phone: 64106655 Fax: 64107319

SHANGHAI BRANCH

4F, Bldg., 27, No. 69, Gui Jing Road
Caohejing, Shanghai, CHINA
Phone: 21-6485-5552 Fax: 21-6485-0775

EPSON HONG KONG LTD.

20/F., Harbour Centre, 25 Harbour Road
Wanchai, Hong Kong
Phone: +852-2585-4600 Fax: +852-2827-4346
Telex: 65542 EPSCO HX

EPSON TAIWAN TECHNOLOGY & TRADING LTD.

10F, No. 287, Nanking East Road, Sec. 3
Taipei
Phone: 02-2717-7360 Fax: 02-2712-9164
Telex: 24444 EPSONTB

HSINCHU OFFICE

13F-3, No. 295, Kuang-Fu Road, Sec. 2
HsinChu 300
Phone: 03-573-9900 Fax: 03-573-9169

EPSON SINGAPORE PTE., LTD.

No. 1 Temasek Avenue, #36-00
Millenia Tower, SINGAPORE 039192
Phone: +65-337-7911 Fax: +65-334-2716

SEIKO EPSON CORPORATION KOREA OFFICE

50F, KLI 63 Bldg., 60 Yoido-dong
Youngdeungpo-Ku, Seoul, 150-763, KOREA
Phone: 02-784-6027 Fax: 02-767-3677

SEIKO EPSON CORPORATION

ELECTRONIC DEVICES MARKETING DIVISION

Electronic Device Marketing Department

IC Marketing & Engineering Group

421-8, Hino, Hino-shi, Tokyo 191-8501, JAPAN
Phone: +81-(0)42-587-5816 Fax: +81-(0)42-587-5624

ED International Marketing Department Europe & U.S.A.

421-8, Hino, Hino-shi, Tokyo 191-8501, JAPAN
Phone: +81-(0)42-587-5812 Fax: +81-(0)42-587-5564

ED International Marketing Department Asia

421-8, Hino, Hino-shi, Tokyo 191-8501, JAPAN
Phone: +81-(0)42-587-5814 Fax: +81-(0)42-587-5110



In pursuit of “**Saving**” **Technology**, Epson electronic devices.
Our lineup of semiconductors, liquid crystal displays and quartz devices
assists in creating the products of our customers’ dreams.
Epson IS energy savings.

SEIKO EPSON CORPORATION
ELECTRONIC DEVICES MARKETING DIVISION

■ EPSON Electronic Devices Website

<http://www.epsondevice.com>