



# RoamAbout™

ENJOY THE FREEDOM OF WIRELESS NETWORKING

## Outdoor Antenna Site Preparation and Installation Guide

[ENTERASYS.COM](http://ENTERASYS.COM)

**ENTERASYS**  

---

**NETWORKS™**

P/N 9033348-05



## NOTICE

Enterasys Networks reserves the right to make changes in specifications and other information contained in this document and its web site without prior notice. The reader should in all cases consult Enterasys Networks to determine whether any such changes have been made.

The hardware, firmware, or software described in this document is subject to change without notice.

IN NO EVENT SHALL ENTERASYS NETWORKS BE LIABLE FOR ANY INCIDENTAL, INDIRECT, SPECIAL, OR CONSEQUENTIAL DAMAGES WHATSOEVER (INCLUDING BUT NOT LIMITED TO LOST PROFITS) ARISING OUT OF OR RELATED TO THIS DOCUMENT, WEB SITE, OR THE INFORMATION CONTAINED IN THEM, EVEN IF ENTERASYS NETWORKS HAS BEEN ADVISED OF, KNEW OF, OR SHOULD HAVE KNOWN OF, THE POSSIBILITY OF SUCH DAMAGES.

© May 2002 Enterasys Networks™

All Rights Reserved.

Enterasys Networks, Inc.  
500 Spaulding Turnpike  
Portsmouth, NH 03801

Part Number: 9033348-05

Web Site: <http://www.enterasys.com/wireless>

Enterasys, Enterasys Networks, RoamAbout, and the RoamAbout logo are trademarks of Enterasys Networks, Inc.

PC Card is a trademark of PCMCIA.

All other trademarks and registered trademarks are the property of their respective holders.

## Regulatory Information

### Canada

The products included with the RoamAbout Outdoor Kit for outdoor antenna installations comply with GL-36 of Industry and Science Canada.

### FCC Notice

Note: The devices included with the outdoor kit have been tested and found to comply with the limits for a Class B digital device, pursuant to part 15 of the FCC Rules. These limits are designed to provide reasonable protection against harmful interference in a residential installation. This equipment generates, uses and can radiate radio frequency energy and, if not installed and used in accordance with the instructions, may cause harmful interference to radio communications. However, there is no guarantee that interference will not occur in a particular installation. If this equipment does cause harmful interference to radio or television reception, which can be determined by turning the equipment off and on, the user is encouraged to try to correct the interference by one or more of the following measures:

- Reorient or relocate the receiving antenna.
- Increase the separation between the equipment and receiver.
- Connect the equipment into an outlet on a circuit different from that to which the receiver is connected.
- Consult the dealer or an experienced radio/TV technician for help.



**CAUTION:** Changes or modifications made to the devices which are not expressly approved by the party responsible for compliance could void the user's authority to operate the equipment.

### Europe - EU Declaration of Conformity

Enterasys Networks declares that the RoamAbout products included in the RoamAbout Outdoor Kit conform to the specifications listed below, following the provisions of the EMC Directive 89/336/EEC:

- ETS 300-826 General EMC requirements for Radio equipment.
- ETS 300-328 Technical requirements for Radio equipment.

### User Information

To comply with the regulations listed above, you must install and use each of the RoamAbout Outdoor Kit components (Lightning Protector, Cables and Antennas) in strict accordance with the instructions in this guide.



**CAUTION:** This equipment may cause exposure to Radio Frequency radiation. Antennas shall be mounted in such a manner to minimize the potential for human contact during normal operation. To avoid the possibility of exceeding FCC radio frequency exposure limits, do not touch the antenna during operation.



**WARNING:** The RoamAbout outdoor antennas need to be installed by an antenna installation professional who can determine, provide, and install the necessary support structure and grounding system. The antenna installation professional should be licensed or certified in accordance with local regulations.

When connecting RoamAbout devices to equipment other than the Enterasys Networks RoamAbout products described in this guide, the antenna installation may no longer comply with the regulations as defined above. In this case, it is the responsibility of the user to ensure that the entire antenna installation complies with local radio regulations.

- Consult the user documentation that came with the other equipment to determine whether additional instructions, cautions, or regulations apply.
- Verify that the antenna installer is aware of these issues and regulations.
- There is no guarantee that interference to radio communications will not occur in a particular commercial installation.
- If this device does cause interference, which can be determined by turning the host equipment off and on, the user should refer to the host equipment documentation, or contact the local equipment supplier.
- In case the device does cause interference with an authorized radio service, the user/operator shall promptly stop operating the device until interference is eliminated.
- Enterasys Networks is not responsible for any radio or television interference caused by unauthorized modification of the devices included with the RoamAbout Outdoor Kit, or the substitution or attachment of connecting cables and equipment other than that specified by Enterasys Networks.
- The correction of interference caused by such unauthorized modification, substitution or attachment is the responsibility of the user.

## Electrical Hazard Warnings

1. Antennas and cables are electrical conductors. Do not touch antennas, RoamAbout Lightning Protectors, or antenna cables during a thunderstorm.
2. The location where you install each antenna must be at a safe distance from power lines or telephone lines. The safe distance should be at least twice the height of the antenna mast **plus** the height of the antenna.
3. The Contact between antenna components and power lines can result in serious personal injury, or possibly death.
4. Do not install antennas or cables where there is any possibility of contact with high-voltage arc-over from power cables or service drops to buildings.
5. During installation or removal, the antenna, supporting mast and/or tower must not be close to any power lines.
6. The low-loss antenna cable that connects the antenna to the lightning protector must be at least 1 meter (3 feet) away from any high voltage or high current cable.
7. Check whether the antenna mast and its guy wires or wall bracket are positioned correctly and secured properly to the roof or wall(s).
8. Check whether the grounding system for the antenna mast, the RoamAbout Access Point, and RoamAbout Lightning Protector have been installed. The grounding system must comply with the requirements as described in the [Chapter 3](#).
9. Always consult a qualified electrician if you are in doubt as to whether the antenna mast, Lightning Protector, and/or RoamAbout Access Point is properly grounded.
10. The low-loss antenna cable between the antenna and the lightning protector must be grounded at all times. If the cable is disconnected at one end for some reason (for example, to replace the lightning protector), you must locally ground the exposed metal connector of the cable during the work.
11. Install the Danger label shipped with the antenna on a plainly visible area of the antenna support structure.



# Contents

---

## Preface

Intended Audience . . . . .	vii
Associated Documents . . . . .	viii
Getting Help . . . . .	ix
Document Conventions . . . . .	x

## 1 Site Preparation

Choosing a Wireless Network Configuration . . . . .	1-2
Determining the Antenna Locations . . . . .	1-2
Maximum Distances Between Antennas . . . . .	1-3
RoamAbout PC Card Variations . . . . .	1-4
Line of Sight . . . . .	1-5
Other Factors That Can Reduce Antenna Range . . . . .	1-7
Other Requirements . . . . .	1-8
Antenna Options . . . . .	1-9
RoamAbout 5 dBi Vehicle-Mount Antenna . . . . .	1-9
RoamAbout 14 dBi Directional Antenna . . . . .	1-10
RoamAbout 7 dBi Omni-Directional Antenna . . . . .	1-14
Contacting an Antenna Installation Company . . . . .	1-18

## 2 AP Placement and Configuration

Determining the Location of the AP . . . . .	2-1
Overview of Connecting Cables to the Access Point . . . . .	2-2
Overview of Connecting Cables to the RoamAbout R2 . . . . .	2-4
Overview of the AP Configuration . . . . .	2-6

### 3 Antenna Installation

Installation Overview . . . . .	3-2
Verify Component Connector Polarity . . . . .	3-2
Grounding System . . . . .	3-5
Lightning Protector Installation . . . . .	3-6
Mounting the Antenna . . . . .	3-8
Requirements for the Directional and 7 dBi Omni-Directional Antennas . . . . .	3-8
Antenna Polarization. . . . .	3-9
Mounting the Directional Antenna . . . . .	3-10
Mounting the Omni-Directional Antenna. . . . .	3-12
Mounting the Vehicle-Mount Antenna. . . . .	3-14
Connecting the Antenna Cables . . . . .	3-15
Antenna Cable Route . . . . .	3-15
Connecting the Cables . . . . .	3-16
Optimizing RoamAbout Outdoor Antenna Placement . . . . .	3-17
Routine Maintenance . . . . .	3-18

### A Specifications

RoamAbout 14 dBi Directional Antenna. . . . .	A-1
RoamAbout 7 dBi Omni-Directional Antenna . . . . .	A-3
Vehicle-Mount Antenna. . . . .	A-4
RoamAbout Pigtail Connection . . . . .	A-5
Low-Loss Antenna Cable. . . . .	A-6
RoamAbout Lightning Protector . . . . .	A-8



---

# Preface

---

This guide describes the requirements that are needed for the successful installation of the RoamAbout outdoor antennas used in a RoamAbout wireless network. A RoamAbout wireless network consists of RoamAbout wireless products, such as the RoamAbout PC Card, RoamAbout Access Point, RoamAbout R2 Wireless Access Platform, and other wireless products that use an 802.11 Direct Sequence (DS) compliant radio.



**ELECTRICAL HAZARD:** *Only qualified personnel should perform installation procedures.*

The RoamAbout outdoor antennas need to be installed by an antenna installation professional who can determine, provide, and install the necessary support structure and grounding system. The antenna installation professional should be licensed or certified in accordance with local regulations.

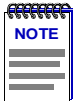

**NOTE:** *AP refers to the Access Point 2000 and the RoamAbout R2 Wireless Access Platform, unless otherwise specified in this document.*

## Intended Audience

**Chapter 1** contains the information needed by a sales engineer or site evaluator to determine the type of outdoor equipment needed to satisfy the customer's outdoor wireless requirements.

**Chapter 2** is for an antenna installation professional and network manager to determine where to place the RoamAbout AP and Lightning Protector. This chapter also provides an overview of cabling and configuring the Access Point.

**Chapter 3** contains the information needed for an antenna installation professional to set up, install, and test the RoamAbout outdoor antennas and cables.

**Appendix A** provides the outdoor antenna specifications.

---

## Associated Documents

The documentation, drivers, and utilities can also be downloaded from the RoamAbout Wireless web site.

Check the RoamAbout Wireless web site regularly for product upgrades.

<http://www.enterasys.com/wireless>

Component	Information Location
RoamAbout Access Point 2000	<i>RoamAbout Access Point 2000 Hardware Installation Guide</i>
RoamAbout R2 Wireless Access Platform	<i>RoamAbout R2 Wireless Access Platform Hardware Installation Guide</i>
RoamAbout Access Point Manager	<i>RoamAbout 802.11 Wireless Networking Guide and the online help</i>
RoamAbout 802.11 DS PC Card	<i>RoamAbout 802.11 PC Card Drivers and Utilities CD-ROM Kit and the online help</i>
RoamAbout 802.11 Drivers	<i>RoamAbout 802.11 PC Card Drivers and Utilities CD-ROM Kit and the online help</i> <i>RoamAbout 802.11 PC Card Drivers and Utilities Setup and Installation Guide</i>
RoamAbout Client Utility	<i>RoamAbout 802.11 PC Card Drivers and Utilities CD-ROM Kit and the online help</i>
RoamAbout ISA Adapter Card	<i>RoamAbout ISA Adapter Installation</i>
RoamAbout PCI Adapter Card	<i>RoamAbout PCI Adapter Installation</i>

---

---

## Getting Help

For additional support related to this device or document, contact Enterasys Networks using one of the following methods:

---

**World Wide Web:** <http://www.enterasys.com/wireless>

---

**Phone:** North America: (603) 332-9400  
Europe: 353 61 701 910  
Asia: +800 8827-2878

---

**Internet mail:** [support@enterasys.com](mailto:support@enterasys.com)

---

To send comments or suggestions concerning this document, contact the Enterasys Networks Technical Writing Department via the following e-mail address: **TechWriting@enterasys.com**

*Make sure you include the document Part Number in the e-mail message.*

---





Before calling Enterasys Networks, please have the following information ready:

- Your Enterasys Networks service contract number
- A description of the problem
- A description of any action(s) already taken to resolve the problem
- The serial and revision numbers of all involved Enterasys Networks products in the network
- A description of your network environment (for example, layout, cable type)
- Network load and frame size at the time of trouble (if known)
- The device history (for example, have you returned the device before, is this a recurring problem)
- Any previous Return Material Authorization (RMA) numbers

---

# Document Conventions

The following icons are used in this document:

Icon	Meaning
	<b>ELECTRICAL HAZARD:</b> Warns against an action that could result in personal injury or death.
	<b>WARNING:</b> Warns against an action that could result in personal injury or death.
	<b>CAUTION:</b> Contains information essential to avoid damage to the equipment.
	<b>NOTE:</b> Calls the reader's attention to any item of information that may be of special importance.

---

# Chapter 1

---

## Site Preparation

---

This chapter describes the site requirements that are needed for the successful installation of the RoamAbout outdoor antennas. It is intended for sales engineers or site evaluators.



**WARNING:** *Site prerequisites should be verified by a person familiar with national codes, local electrical codes, and with other regulations governing this type of installation. Enterasys Networks, its channel partners, resellers, and distributors assume no liability for personal injury, property damage, or violation of government regulations that may arise from failing to comply with the instructions in this guide.*

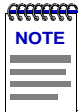

**NOTE:** *AP refers to the Access Point 2000 and the RoamAbout R2 Wireless Access Platform, unless otherwise specified in this document.*

If after reviewing this document you require additional technical information or support prior to ordering product, contact your authorized Enterasys Networks Representative or see the RoamAbout web site:

<http://www.enterasys.com/wireless>

## Choosing a Wireless Network Configuration

The antennas you need depend on the wireless network configuration:

- LAN-to-LAN, Point-to-Point

This is a wireless link between two APs that connects two separate wired LANs. Typically, two directional antennas are used.

- LAN-to-LAN, Point-to-Multipoint

In a point-to-multipoint network, up to seven APs provide wireless links to connect up to seven LANs. One AP is designated as the central (multipoint) AP. The other APs are called endpoints and only communicate with the Central AP. Typically, the Central AP connects to an omni-directional antenna. The endpoint APs connect to a directional antenna.

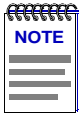

*NOTE: Slot 2 of the RoamAbout R2 does not support Multipoint mode.*

- Wireless Infrastructure

This is an inside/outside wireless network where one or more APs are used to connect clients to a wired LAN. Typically, the APs use an omni-directional antenna or a sector antenna, and the clients use a vehicle-mount antenna. An example of this type of network is a warehouse where drivers in forklifts need to access the LAN.

## Determining the Antenna Locations

The locations where the antennas can be placed relative to one another and the distance between them are based on the following factors:

- Type of antennas. The RoamAbout antennas are described in the **“Antenna Options” section on page 1-9**.
- Length of cable from the antenna to the AP.
- Data rate required.
- Obstructions in the signal path.
- Type of RoamAbout PC Card.
- In a LAN-to-LAN network, the distance between the buildings.
- In a wireless infrastructure network, the area around the antenna where clients need to communicate with the AP.

Typically, the RoamAbout directional and omni-directional antennas are installed on rooftops. The directional antenna can also be installed to the side of a building. The vehicle-mount antenna is mounted to a vehicle and connected to the client with a 2.5 meter (8 foot) cable. The following sections describe the factors that affect the range of the antennas.

## Maximum Distances Between Antennas

The following tables list the maximum distance between antennas at a given data rate. The distance in tables are based on the following:

- 15 meter (50 foot) low-loss antenna cable from the antenna to the AP.
- Type of PC Card (standard or Hi-Gain matched). See the **“RoamAbout PC Card Variations”** section on page 1-4.
- No obstructions in the line of sight. See **Table 1-1** and **Table 1-2**. The Line of Sight Clearance column indicates the radius of the radio beam. Obstructions in the line of sight reduces the total distance, as described in the **“Line of Sight”** section on page 1-5.

**Table 1-1: Distances and Line of Sight Clearance (FCC)**

Data Rate Mbit/s	14 dBi Yagi to 14 dBi Yagi		14 dBi Yagi to 7 dBi Omni		7 dBi Omni to Vehicle-Mount	
	Distance	Line of Sight Clearance	Distance	Line of Sight Clearance	Distance	Line of Sight Clearance
11	5.6 km (3.5 mi)	9.8 m (33 ft)	2.5 km (1.5 mi)	6.3 m (21 ft)	0.8 km (0.5 mi)	3.4 m (11.2 ft)
5.5	7.9 km (4.9 mi)	12.1 m (40 ft)	3.5 km (2.1 mi)	7.5 m (25 ft)	1.1 km (0.7 mi)	4.1 m (13.5 ft)
2	11.2 km (6.9 mi)	15.4 m (51 ft)	5 km (3.1 mi)	9.1 m (30 ft)	2 km (1.2 mi)	5.6 m (18.4 ft)
1	15.8 km (9.8 mi)	20.3 m (67 ft)	7.1 km (4.4 mi)	11.3 m (37 ft)	2.5 km (1.5 mi)	6.3 m (21 ft)

**Table 1-2: Distances and Line of Sight Clearance ETSI**

Data Rate Mbit/s	14 dBi Yagi to 14 dBi Yagi <sup>1</sup>		14 dBi Yagi <sup>1</sup> to 7 dBi Omni		7 dBi Omni to Vehicle-Mount	
	Distance	Line of Sight Clearance	Distance	Line of Sight Clearance	Distance	Line of Sight Clearance
11	2.5 km (1.5 mi)	6.3 m (21 ft)	1.1 km (0.7 mi)	4.1 m (14 ft)	0.8 km (0.5 mi)	3.4 m (11.2 ft)
5.5	3.5 km (2.1 mi)	7.5 m (25 ft)	1.6 km (1 mi)	4.9 m (16 ft)	1.1 km (0.7 mi)	4.1 m (13.5 ft)
2	5 km (3.1 mi)	9.1 m (30 ft)	2.2 km (1.4 mi)	5.9 m (20 ft)	2 km (1.2 mi)	5.6 m (18.4 ft)
1	7.1 km (4.4 mi)	11.3 m (37 ft)	3.2 km (2 mi)	7.1 m (24 ft)	2.5 km (1.5 mi)	6.3 m (21 ft)

<sup>1</sup> The Yagi antenna must be connected to an AP configured with the Hi-Gain matched RoamAbout PC Card.

## RoamAbout PC Card Variations

There are two variations of the RoamAbout PC Card: standard and Hi-Gain matched.

The Hi-Gain matched variation of the RoamAbout PC Card is only used when connecting to a directional antenna in countries that adhere to the European Telecommunications Standards Institute (ETSI) standards.

All other countries and other configurations use the same standard RoamAbout PC Card. For example, all countries use the standard RoamAbout PC Card in these configurations:

- PC Card is not connected to an antenna.
- PC Card is connected to a 7 dBi omni-directional antenna.
- PC Card is connected to a vehicle-mount antenna.

Countries that adhere to the Federal Communications Commission (FCC) standards use the standard RoamAbout PC Card in all configurations.



## Line of Sight

The shape of the radio beam, defined as the Fresnel Zone, is widest in the middle. The Fresnel Zone is shown as the gray area between the antennas in **Figure 1-1**. The exact shape and width of the Fresnel Zone is determined by the distance between the antenna and frequency of the radio signal.

The radius of the radio beam, shown as the lower half of the Fresnel Zone, is the distance from the center of the beam outward in any direction. The length of the radius is shown in **Table 1-1** and **Table 1-2** as the line of sight clearance. The length of the radius is not based on the data rate and the type of antenna.

**Figure 1-1: Fresnel Zone and Line of Sight Clearance**

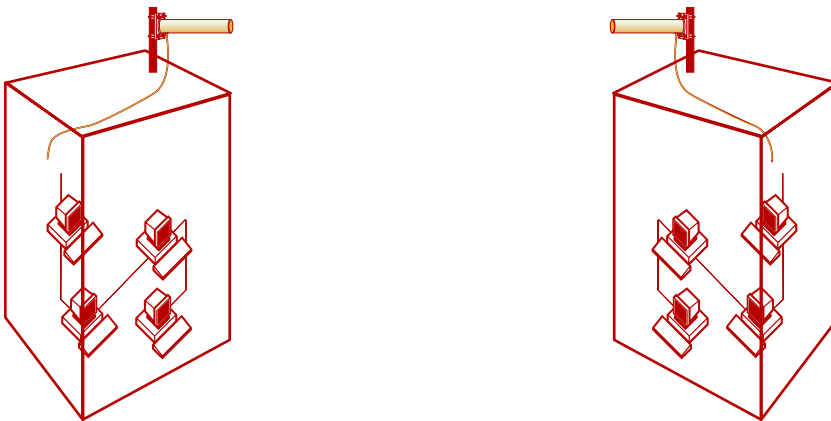

If a significant part of the Fresnel Zone is obstructed, a portion of radio energy is lost, resulting in reduced performance. For optimal performance, ensure that the antenna products you choose, in combination with the height of the antenna installation above ground, provide sufficient clearance to allow your antenna installation to cover the distance between the two sites.

Obstacles within the line of sight can significantly reduce the distance and performance. Obstructions include neighboring buildings, trees, and power lines as shown in **Figure 1-2**.



## Other Factors That Can Reduce Antenna Range

Large reflecting surfaces that are parallel or partly perpendicular to the radio signal cause reflections of the radio signal (see **Figure 1-3**). Examples of reflecting surfaces are buildings with low-emissivity (low-e) glass, crowded parking lots, water, moist earth, moist vegetation, and above-ground power or telephone lines.

Because surrounding objects, such as trees, power lines, and other antennas, seriously reduce efficiency of the antenna, it is very important to mount the antenna as high and clear of obstacles as possible.

**Figure 1-3: Large Reflecting Surfaces**

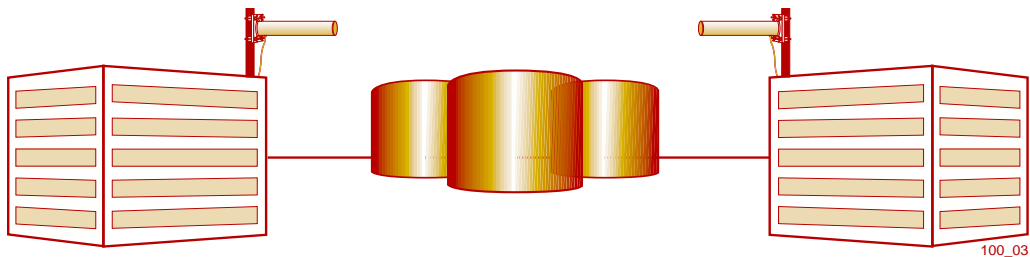

Large storage tanks which are common in industrial areas

### Other Requirements

The following describes other requirements to meet before installing the RoamAbout outdoor antennas.

- **Lightning Protection**

A lightning rod must be placed close to the antenna mast or wall bracket. This is required to protect the antenna from direct lightning strikes.

- **Grounding System**

Direct earth grounding of the antenna and the Lightning Protector is necessary to protect the installation from lightning and the build-up of static electricity. The wireless device and the Lightning Protector must be connected to the same earth ground using separate grounds. The antenna and the mounting structure require separate grounds to the same earth ground, using an equipotential bonding conductor. Check with a certified antenna installer to make sure the antenna is properly grounded.

Ensure that the cable between the antenna and Lightning Protector is at least 0.9 meters (3 feet) away from high-voltage or high-current cable.

- **Antenna Height**

If you are mounting the antenna on a roof, it must be at least 1.5 meters (5 feet) above the roof line.

If you are mounting the directional antenna to a wall of a building, it must be high enough to achieve a clear line of sight. Mounting an omni-directional antenna to the side of a building can cause signal reflection and reduce distance.

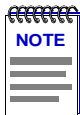

***NOTE:** The installer is responsible for local building codes.*

- **AP placement**

The AP should be located indoors and connected to the outdoor antenna with a standard 6 meter (20 foot), 15 meter (50 foot), or 22 meter (75 foot) low-loss cable. A longer cable could cause additional signal loss and decrease the distance between antennas.

# Antenna Options

The following sections describe the RoamAbout outdoor antennas. Appendix A contains the specifications for each antenna.

## RoamAbout 5 dBi Vehicle-Mount Antenna

The RoamAbout vehicle-mount antenna (**Figure 1-4**) is a broadband antenna for the 2.4 GHz frequency band featuring an omni-directional pattern with a nominal gain of 5 dBi. The vehicle-mount antenna can be mounted on vehicles, such as fork-lift trucks, that need continuous access to network data whether inside or outside of the building.

Packaged Kit/ Component	Component Part Numbers by Domain	
	FCC	ETSI*
VEHICLE-MOUNT ANTENNA	CSIES-AA-MO5	CSIES-AB-MO5

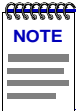

*NOTE: The pigtail cable, part number CSIES-\*\*-PT250, used with the Vehicle Mount Antenna is sold separately.*

**Figure 1-4: Vehicle-Mount Antenna**

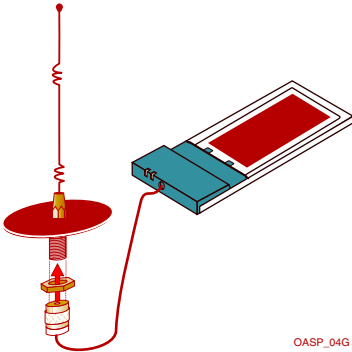

OASP\_04G

## RoamAbout 14 dBi Directional Antenna

The directional antenna is a totally enclosed 16-element Yagi designed for point-to-point communications. The antenna is normally mounted on a mast and vertically polarized. The following sections show the components and part numbers in the RoamAbout directional antenna kit.

### Access Point 2000

**Table 1-3** lists the packaged kit components. The numbers in the first column correspond to the numbers in **Figure 1-5**, which shows an example of a RoamAbout Access Point 2000 cabling configuration.

**Table 1-3: Access Point 2000 Directional Antenna Component Part Numbers**

#	Packaged Kit/ Component	Component Part Numbers by Domain				
		FCC	ETSI*	France	Asia Pacific FCC	Asia Pacific ETSI*
	<b>OUTDOOR ANTENNA KIT</b>	CSIED-AA	CSIED-AB	CSIED-AF	CSIED-AP-FCC	CSIED-AP-ETSI
1	<b>Antenna</b>	CSIES-AA-Y14	CSIES-AB-Y14	CSIES-AB-Y14	CSIES-AB-Y14	CSIES-AB-Y14
2	<b>50-foot Cable</b>	CSIES-AA-C50	CSIES-AB-C50	CSIES-AB-C50	CSIES-AB-C50	CSIES-AB-C50
3	<b>Pigtail Connection</b>	CSIES-AA-PT50	CSIES-AB-PT50	CSIES-AB-PT50	CSIES-AB-PT50	CSIES-AB-PT50
4	<b>Access Point 2000</b>	CSIWS-AA	CSIWS-AB	CSIWS-AB	CSIWS-AB	CSIWS-AB
5	<b>PC Card</b>	CSIBD-AA-128**	CSILD-AB	CSILD-AF	CSIBD-AA	CSIBD-AB
6	<b>Lightning Protector</b>	CSIES-AA-LP	CSIES-AB-LP	CSIES-AB-LP	CSIES-AB-LP	CSIES-AB-LP

\*European Telecommunications Standards Institute

\*\*128-bit encryption RoamAbout PC Card



**NOTE:** An optional 75-foot cable, part number CSIES-AA-C75 or CSIES-AB-C75, not included in the kit is also available. Contact your Enterasys Networks Representative for more information.

Figure 1-5: Yagi Antenna Configuration Example (AP 2000)

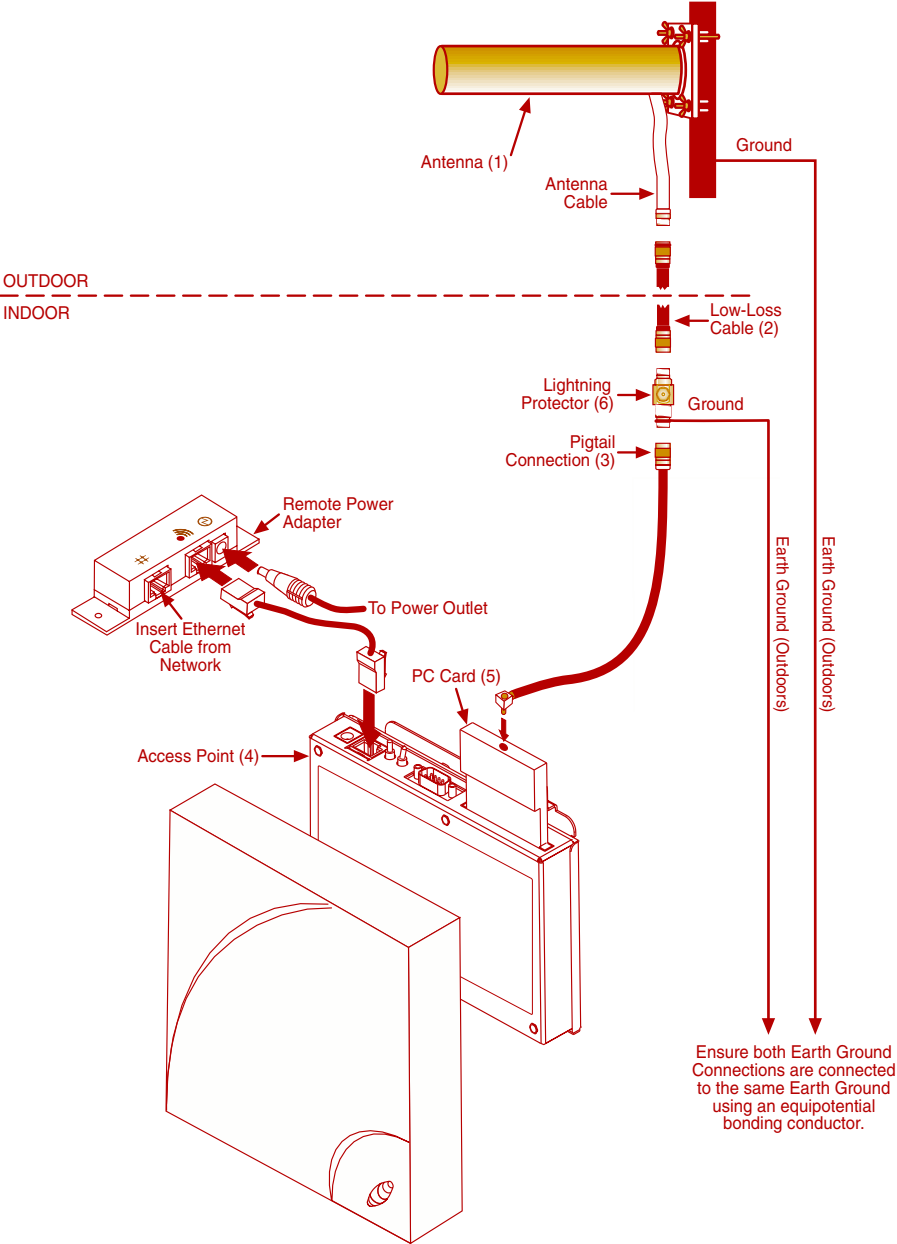

## RoamAbout R2

**Table 1-4** lists the packaged kit components. The numbers in the first column correspond to the numbers in **Figure 1-6**, which shows an example of a RoamAbout R2 cabling configuration.

**Table 1-4: RoamAbout R2 Directional Antenna Component Part Numbers**

#	Packaged Kit/ Component	Component Part Numbers by Domain	
		FCC	ETSI*
	<b>OUTDOOR ANTENNA KIT</b>	RBTED-AA	RBTED-AB
1	<b>Antenna</b>	CSIES-AB-Y14	CSIES-AB-Y14
2	<b>50-foot Cable</b>	CSIES-AB-C50	CSIES-AB-C50
3	<b>Pigtail Connection</b>	CSIES-AB-PT50	CSIES-AB-PT50
4	<b>RoamAbout R2</b>	RBTR2-AB	RBTR2-AB
5	<b>PC Card</b>	CSIBD-AA-128**	CSILD-AB-128**
6	<b>Lightning Protector</b>	CSIES-AB-LP	CSIES-AB-LP

\*European Telecommunications Standards Institute

\*\*128-bit encryption RoamAbout PC Card

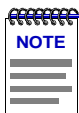

**NOTE:** An optional 75-foot cable, part number CSIES-AB-C75, not included in the kit is also available. Contact your Enterasys Networks Representative for more information.



Figure 1-6: Yagi Antenna Configuration Example (RoamAbout R2)

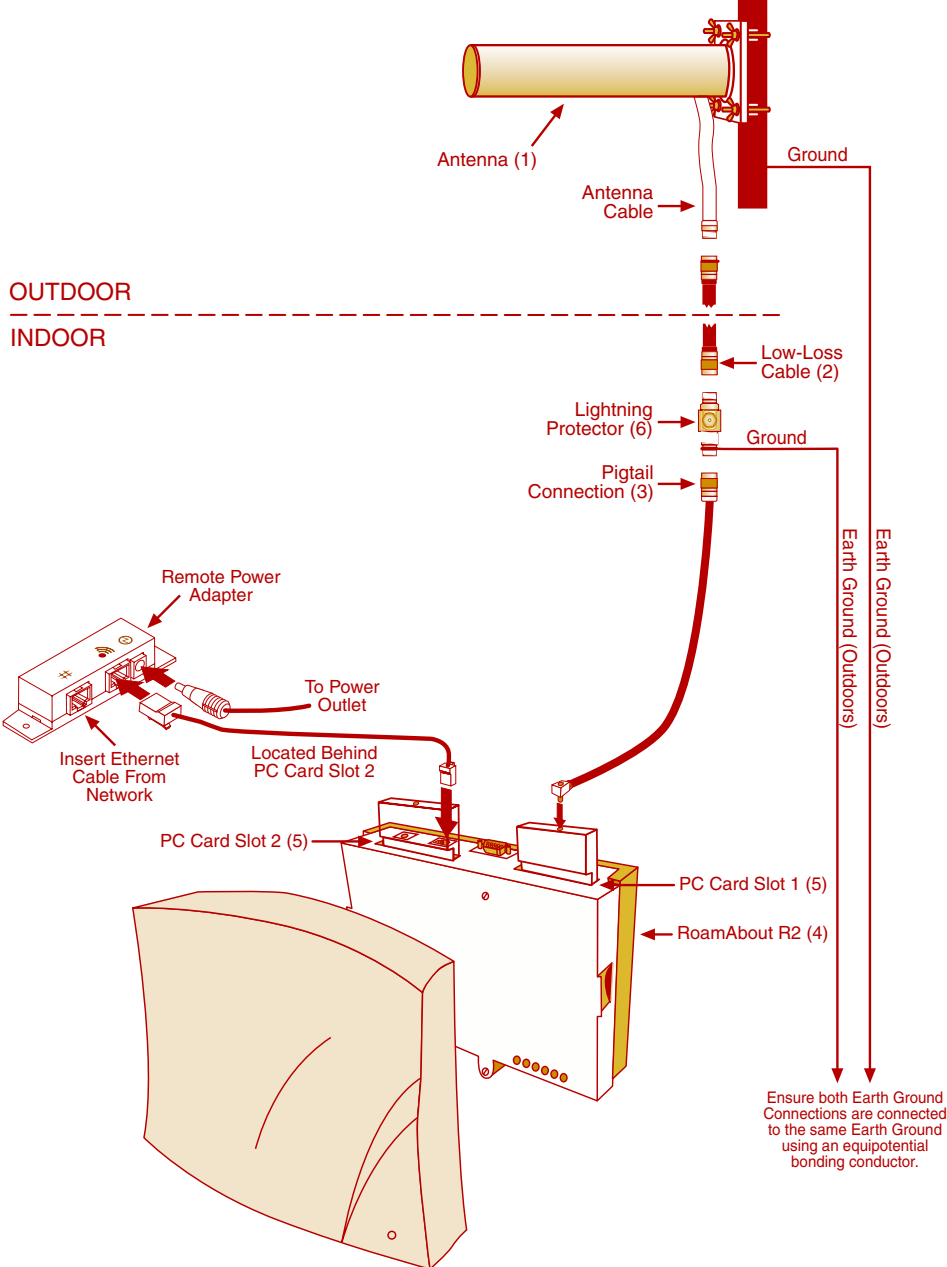

## RoamAbout 7 dBi Omni-Directional Antenna

The RoamAbout omni-directional antenna is a broadband antenna for the 2.4 GHz frequency band featuring an omni-directional pattern with a nominal gain of 7 dBi.

This antenna is encapsulated in a weatherproof protective covering. With the hardware provided, this vertically-polarized antenna can be mounted on an antenna mast with an outside diameter of up to 51mm (2 in.).

### Access Point 2000

**Table 1-5** lists the antenna and related components with their part numbers. The numbers in the first column correspond to the numbers in **Figure 1-7**, which shows an example of a RoamAbout Access Point 2000 cabling configuration.

**Table 1-5: Omni-Directional Component Part Numbers (Access Point 2000)**

#	Packaged Kit/ Component	Component Part Numbers by Domain			
		FCC	ETSI* and Asia Pacific ETSI*	France	Asia Pacific FCC
	<b>OUTDOOR ANTENNA KIT</b>	CSIED-AA-M07	CSIED-AB-M07	CSIED-AF-M07	CSIED-APFCCM7
1	<b>Antenna</b>	CSIES-AA-M07	CSIES-AB-M07	CSIES-AB-M07	CSIES-AB-M07
2	<b>50-foot Cable</b>	CSIES-AA-C50	CSIES-AB-C50	CSIES-AB-C50	CSIES-AB-C50
3	<b>Pigtail Connection</b>	CSIES-AA-PT50	CSIES-AB-PT50	CSIES-AB-PT50	CSIES-AB-PT50
4	<b>Access Point 2000</b>	CSIWS-AA	CSIWS-AB	CSIWS-AB	CSIWS-AB
5	<b>PC Card</b>	CSIBD-AA-128**	CSIBD-AB	CSIBD-AF	CSIBD-AA
6	<b>Lightning Protector</b>	CSIES-AA-LP	CSIES-AB-LP	CSIES-AB-LP	CSIES-AB-LP

\* European Telecommunications Standards Institute

\*\*128-bit encryption RoamAbout PC Card



**NOTE:** An optional 75-foot cable, part number CSIES-AA-C75 or CSIES-AB-C75, not included in the kit is also available. Contact your Enterasys Networks Representative for more information.

**Figure 1-7: Omni-Directional Antenna Configuration Example (Access Point 2000)**

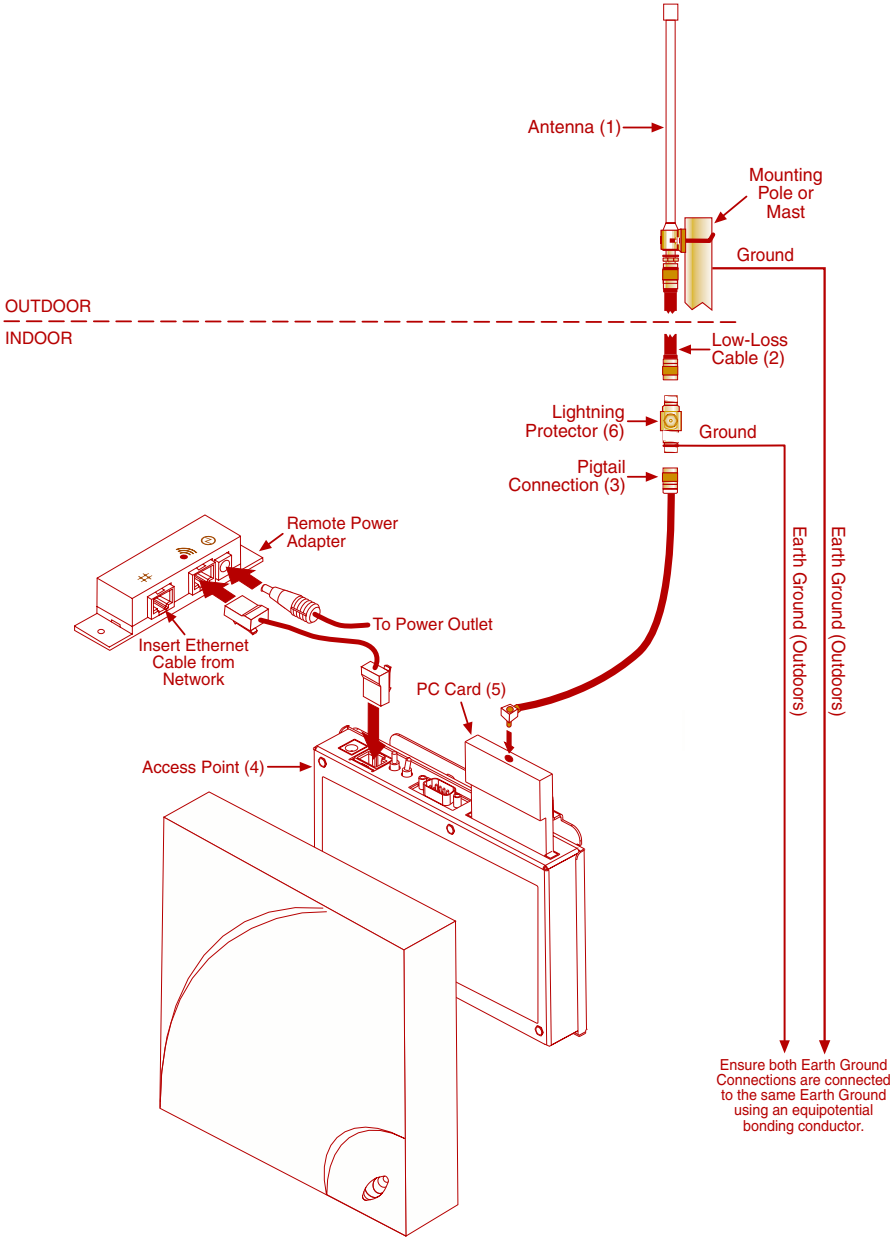

## RoamAbout R2

**Table 1-6** lists the antenna and related components with their part numbers. The numbers in the first column correspond to the numbers in **Figure 1-8**, which shows an example of a RoamAbout R2 cabling configuration.

**Table 1-6: RoamAbout R2 Component Omni-Directional Part Numbers**

#	Packaged Kit/ Component	Component Part Numbers by Domain	
		FCC	ETSI* and Asia Pacific ETSI*
	<b>OUTDOOR ANTENNA KIT</b>	RBTED-AA-M07	RBTED-AB-M07
1	<b>Antenna</b>	CSIES-AB-M07	CSIES-AB-M07
2	<b>50-foot Cable</b>	CSIES-AB-C50	CSIES-AB-C50
3	<b>Pigtail Connection</b>	CSIES-AB-PT50	CSIES-AB-PT50
4	<b>RoamAbout R2</b>	RBTR2-AB	RBTR2-AB
5	<b>PC Card</b>	CSIBD-AA-128**	CSIBD-AB- 128**
6	<b>Lightning Protector</b>	CSIES-AB-LP	CSIES-AB-LP

\* European Telecommunications Standards Institute

\*\*128-bit encryption RoamAbout PC Card

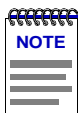

**NOTE:** An optional 75-foot cable, part number CSIES-AB-C75, not included in the kit is also available. Contact your Enterasys Networks Representative for more information.

**Figure 1-8: Omni-Directional Antenna Configuration Example (RoamAbout R2)**

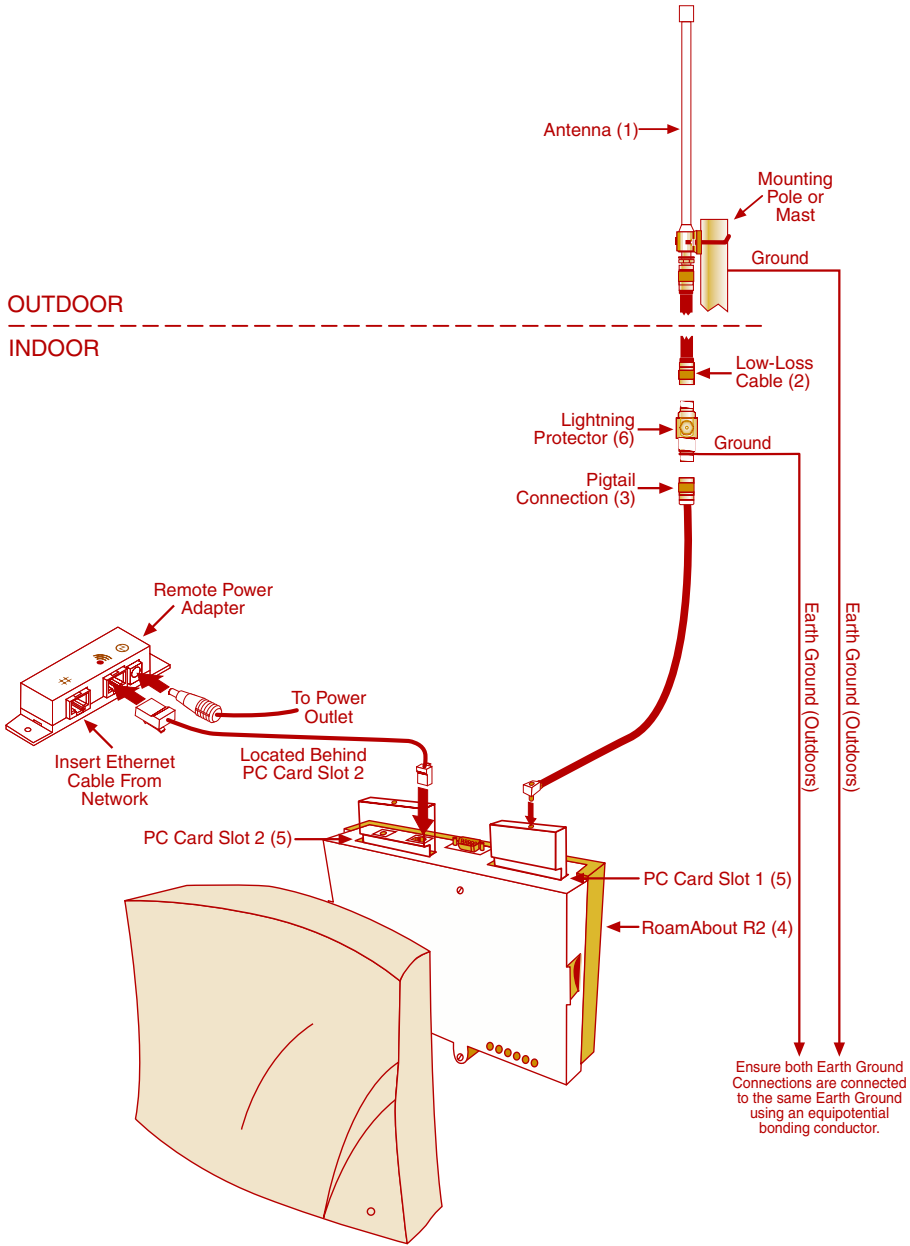

## Contacting an Antenna Installation Company

Have an antenna installation professional install the outdoor antennas. The antenna installer provides the expertise to properly install, secure, and ground your antenna. The following describes tasks that the installer may need to perform.

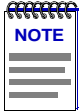

***NOTE:** The antenna installation professional should be licensed or certified in accordance with local regulations.*

### Lightning Protection

- Determine the mounting location for the lightning rod (positioned near the antenna).
- Ensure an earth ground location for the antenna structure and lightning protector.

### Mounting Requirements

- Determine the type of mounting that is required (tripod, wall mount, etc.).
- Determine the guy wires needed. Typically, three guy wires are needed for each 3 meter (10 foot) section of the mast; for example, 6 meters (20 feet) of mast requires six guy wires.

### Line of Sight

- Determine the mounting location for the antenna.
- Ensure that the back of the antenna is clear.
- Ensure that remote and local antennas can see each other.
- Ensure that no obstacles are in the direct path or within the defined zone of the two sites.
- Consider whether any Radio Frequency (RF) interference is present.

**Installation Requirements**

- √ Determine the best location for the AP.
- √ Determine the length of cable required from the antenna to the AP.
- √ Ensure the location has an accessible Ethernet connection.
- √ Determine the distance between buildings.

You may need to provide the following distances when contacting the antenna installation company:

Distance between the antennas  
(building-to-building network): \_\_\_\_\_

Coverage area required (wireless  
infrastructure network configuration): \_\_\_\_\_

Height of building A: \_\_\_\_\_

Height of building B: \_\_\_\_\_

All possible obstacles that can  
interfere with the defined radius.  
\_\_\_\_\_  
\_\_\_\_\_







## Overview of Connecting Cables to the Access Point

Before cabling the Access Point 2000, you should install the Access Point to a wall or ceiling. For detailed hardware installation procedures, see the *RoamAbout Access Point 2000 Hardware Installation Guide*. **Figure 2-1** provides you with an illustration of the steps listed in the following procedure.

1. Insert the PC Card into the Access Point. Refer to the *RoamAbout 802.11 PC Card Installation Guide* for Regulatory and Installation information before installing the PC Card.

**Figure 2-1: Access Point 2000 Installation Overview**

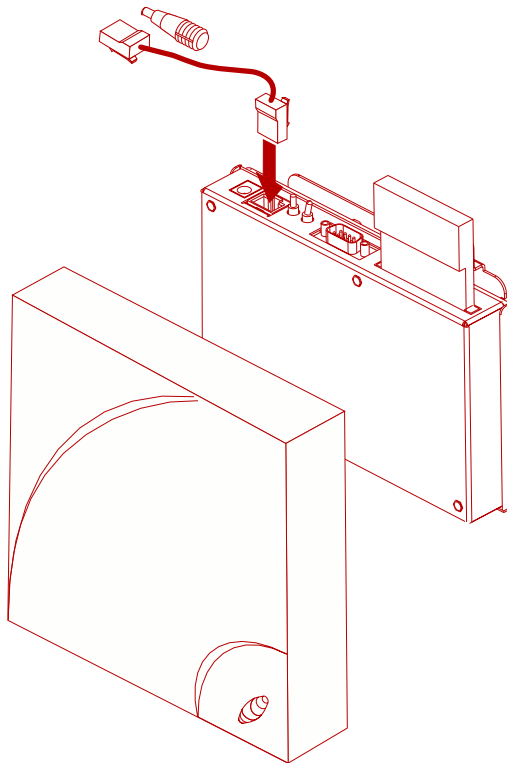

2. Remove the plastic cap from the PC Card and connect the pigtail cable. After the Lightning Protector has been installed and grounded, connect the other end of the pigtail cable to the Lightning Protector.
3. If using the remote power option, connect the Ethernet cable from the Access Point to the Access Point connector on the remote power adapter.
4. Record the Access Point's MAC address on the front label. You need this address when configuring the Access Point from the AP Manager program.
5. If using the remote power option, connect the power adapter to the Power connector on the remote power adapter. Do NOT connect the power adapter to the power source at this time.
6. If using the remote power option, connect the Ethernet cable from the site network to the Ethernet connector on the remote power adapter.

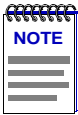

***NOTE:** If you are not using the remote power option, connect the network and power cables directly to the Access Point.*

7. Optionally, snap the cover on. Some installation configurations do not require the plastic cover.
8. Connect the power adapter to the power source.



## Overview of Connecting Cables to the RoamAbout R2

---

2. Remove the plastic cap from the PC Card(s) and connect the pigtail cable. After the Lightning Protector has been installed and grounded, connect the other end of the pigtail cable to the Lightning Protector.
3. Connect the Ethernet cable from the RoamAbout R2 to the RoamAbout R2 connector on the power adapter.
4. Record the RoamAbout R2's MAC address (located on the side of the unit). You need this address when configuring the RoamAbout R2 from the AP Manager program.
5. If using the remote power option, connect the power adapter to the power connector on the remote power adapter. Do NOT connect the power adapter to the power source at this time.
6. If using the remote power option, connect the Ethernet cable from the site network to the Ethernet connector on the remote power adapter.

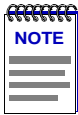

***NOTE:** If you are not using the remote power option, connect the network and power cables directly to the RoamAbout R2.*

7. Optionally, snap on the security cover.
8. Connect the power adapter to the power source.

## Overview of the AP Configuration

The following provides an overview of configuring the AP with the RoamAbout AP Manager. For detailed procedures, see the *RoamAbout 802.11 Wireless Networking Guide* or click the **Help** button in the AP Manager.

Before you begin, you need the following:

- A valid unused IP address for each AP from the network administrator.
  - The wireless MAC address of both APs. The wireless MAC address is NOT the same as the wired MAC address printed on the AP label. Perform one of the following to see the wireless MAC address:
    - If both APs are currently managed by the AP Manager, select each AP from the **Managed List** field and click the **Hardware** button.
    - Using the RoamAbout R2 console port at each RoamAbout, choose **Current Settings** from the RoamAbout R2 Installation Menu.
    - Using the Access Point console port at each Access Point, choose **Show Current Settings** from the RoamAbout Access Point Installation Menu.
    - Check the back of the PC Card used in the APs. The MAC address of the PC Card is the AP's wireless MAC address.
1. Install the AP Manager, on a computer located on the same wired network as the AP. Supported operating systems are Windows 95, 98, 2000, Me, Windows NT (V4.0 or later), or Windows XP.
  2. Open the AP Manager (**Start** button, **Programs**→**RoamAbout**→ **RoamAbout AP Manager**).
  3. Click the **Setup/Add New AP** button (**Figure 2-3**). When prompted, click **Yes** to load an IP address. The Load IP Address dialog box appears.
  4. Refer to the RoamAbout AP Manager online help and the *RoamAbout 802.11 Wireless Networking Guide* for configuration information.

Figure 2-3: RoamAbout AP Manager

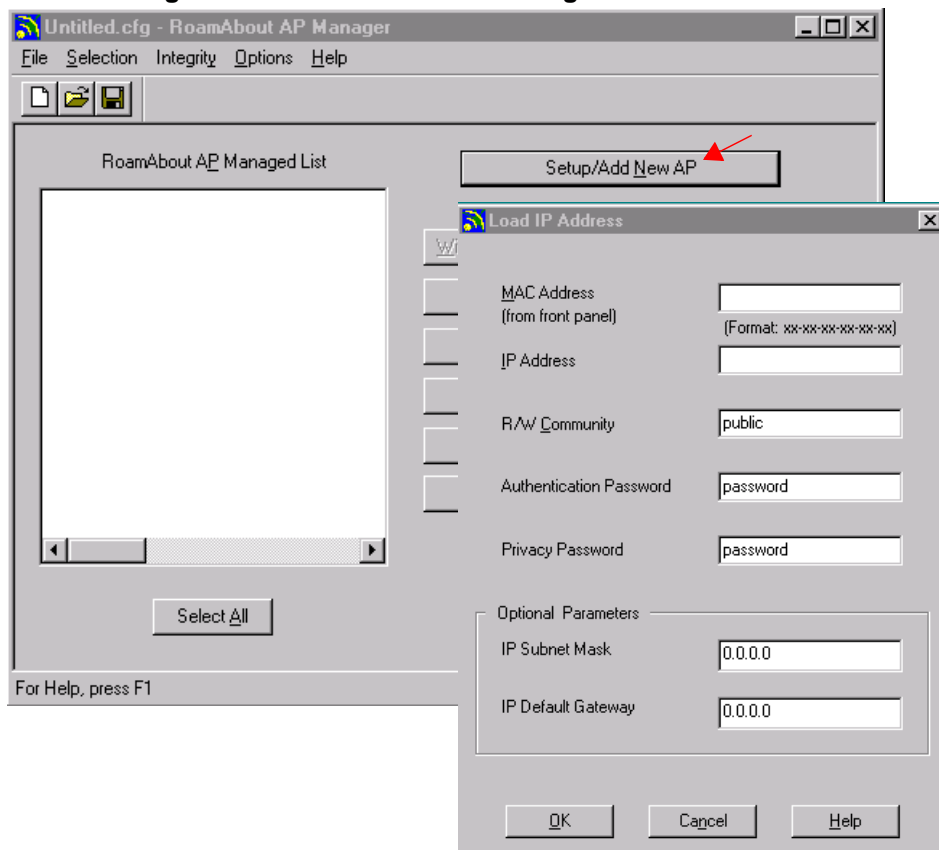





---

## Antenna Installation

---

This chapter provides the information necessary for a professional antenna installer to install the RoamAbout antennas.



***ELECTRICAL HARZARD:*** Antennas should only be installed by a qualified antenna installer. The antenna installation professional should be licensed or certified in accordance with local regulations.

*Do not install the antenna in wet, windy, icy, or otherwise unsafe weather conditions.*

The RoamAbout outdoor antenna kits do NOT provide the following items, which may be necessary to install the antenna:

- Mast or other antenna support structure
- Guy wires
- All cables or other hardware necessary for a complete grounding system
- Waterproof tape

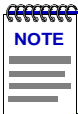

***NOTE:*** It is the responsibility of the end-user to ensure that an outdoor antenna installation complies with local radio regulations.

## Installation Overview

The installation process is summarized in the following steps. The following sections in this chapter provide additional details.

1. Make sure the APs are mounted and configured as specified in [Chapter 2](#).
2. Check the cable connectors to verify that they are the correct polarity for your installation.
3. Plan and implement a grounding system that meets local electrical codes and safety standards.
4. Install the RoamAbout Lightning Protector.
5. Provide and install an antenna support structure as necessary. Make sure that the support structure is connected to the grounding system.
6. Connect the exposed metal connectors of the low-loss antenna cable to the grounding system.
7. Mount the antenna to the support structure.
8. Connect the antenna cables.
9. Route and connect the low-loss antenna cable to the RoamAbout Lightning Protector that has been installed indoors.
10. Connect the cable assembly from the RoamAbout PC Card in the AP to the Lightning Protector.
11. Run the AP Manager Link Test program to aim the antenna and verify optimal placement.
12. After verifying that the communications link is fully operational, secure all cables and use weatherproofing tape to seal all outdoor connectors.

## Verify Component Connector Polarity

Before you start the antenna installation, refer to [Figure 3-1](#) (Access Point 2000) and [Figure 3-2](#) (RoamAbout R2) to verify that the polarity of each connector is correct for your installation. The components supplied with your outdoor antenna kit are configured with either Standard-N connectors or Reverse Polarity-N connectors, subject to the country where the kit was purchased.

**Figure 3-1: Selecting the Correct N-Type Connector for the Access Point 2000**

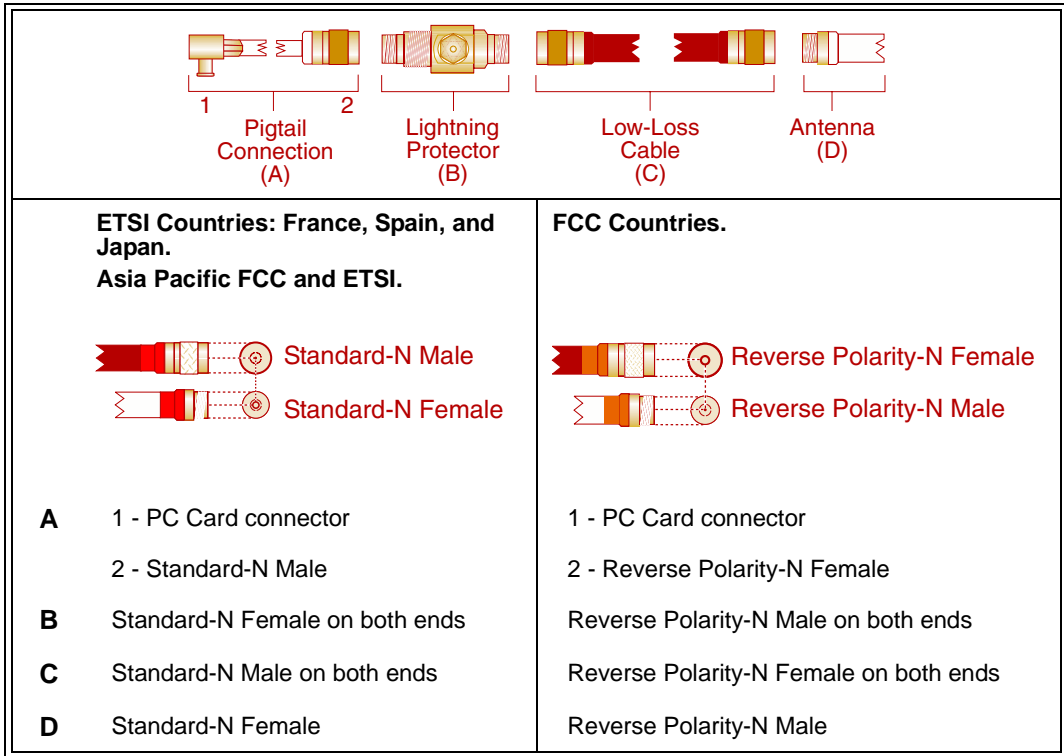

The term Male or Female does not refer to the connector thread, but to its center pin.

- Male connectors have a solid center pin
- Female connectors have a hollow center pin

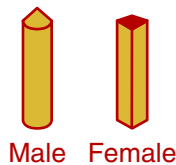

If you purchase individual components, make sure you specify the correct N-Type connectors to match the configuration that applies to your country.

**Figure 3-2: Selecting the Correct N-Type Connector for the RoamAbout R2**

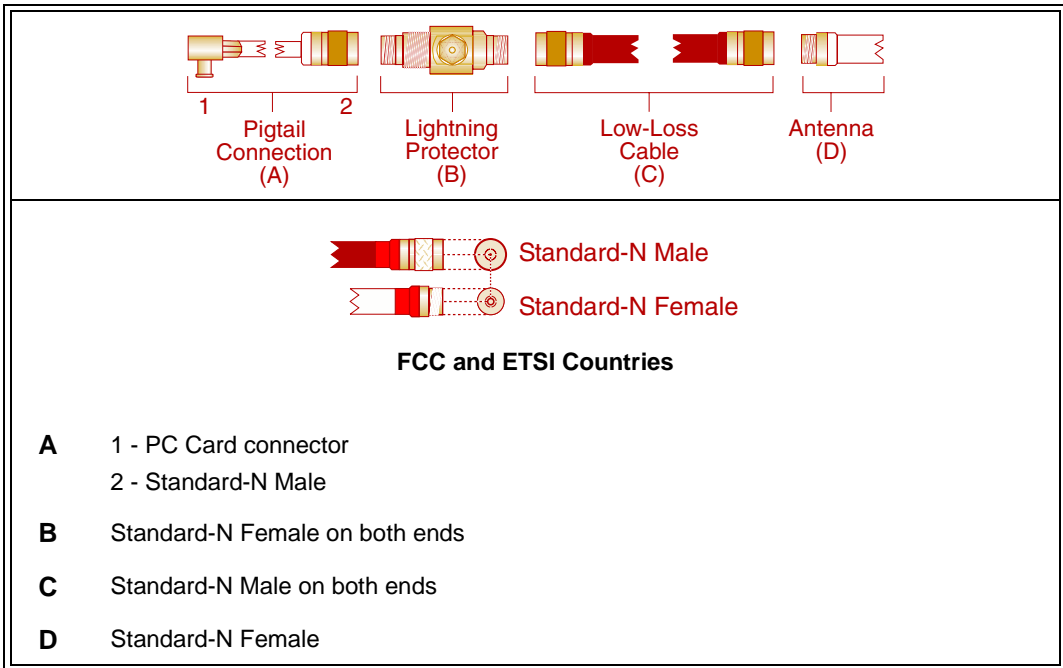

The term Male or Female does not refer to the connector thread, but to its center pin.

- Male connectors have a solid center pin
- Female connectors have a hollow center pin

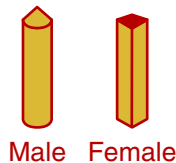

If you purchase individual components, make sure you specify the correct N-Type connectors to match the configuration that applies to your country.

## Grounding System

Direct earth grounding of the antenna and the Lightning Protector is necessary to protect the installation from lightning and the build-up of static electricity.



**CAUTION:** *The antenna mast, RoamAbout AP, and lightning protector must be connected to the same earth ground (with separate grounds), using an equipotential bonding conductor. A good electrical connection should be made to one or more ground rods using at least a 10AWG ground wire and non-corrosive hardware. The grounding system must comply with the National Electrical Code and safety standards that apply in your country. Always check with a qualified electrician to determine whether your outdoor installation is properly grounded.*

The grounding system must satisfy the following requirements:

- The antenna mast, RoamAbout AP, and RoamAbout Lightning Protector must be connected to the same earth ground using an equipotential bonding conductor.
- The antenna and the mounting structure require a separate earth ground connection. Check with a certified antenna installer to make sure the antenna is properly grounded.
- Ensure that the cable between the antenna and Lightning Protector is at least 0.9 meters (3 feet) away from high-voltage or high-current cable.
- A good electrical connection must be made to one or more ground rods, using at least a 10AWG ground wire and noncorrosive hardware.
- The grounding system must comply with electrical codes and safety standards that apply in your locality.

Have a qualified electrician verify that your RoamAbout outdoor installation is properly grounded.



**CAUTION:** *A properly installed safety grounding system is necessary to protect your RoamAbout outdoor installation from lightning strikes and static electricity build-up.*

## Lightning Protector Installation

Lightning protection is designed to protect people, property and equipment by providing a path to the ground whenever lightning strikes your antenna installation. The RoamAbout Lightning Protector is an indispensable part of such a grounding system to protect your electronic equipment from transients and/or electrostatic discharges at the antenna.

For optimal protection, the location of the RoamAbout Lightning Protector:

- Must be as close as possible to the point where the antenna cable enters the building.
- Allow for easy access to the Lightning Protector so that the Gas Discharge Tube (GDT) in the Lightning Protector can be replaced as necessary.
- Provide a connection to the same grounding system as the RoamAbout AP and the antenna mast as described in the **“Verify Component Connector Polarity” section on page 3-2.**

To install the RoamAbout Lightning Protector, perform the following steps:

1. Determine a suitable location for the Lightning Protector as described in **Chapter 2**.
2. As shown in **Figure 3-3**, secure bracket (A) to the wall using two screws (F).
3. Use a ring-terminal to connect ground-wire (C) to bolt (B). *The ring-terminal and ground wire are provided by the installer.*
4. Secure bolt (B) to the bracket

# Mounting the Antenna

This section includes requirements and mounting guidelines for the RoamAbout outdoor antennas.

## Requirements for the Directional and 7 dBi Omni-Directional Antennas

To minimize the influence of obstacles, signal interference or reflections, install the antenna at least 2 meters (6 feet) away from all other antennas.

If you need to mount multiple antennas on a single mast, alternate the mounting of directional antennas for vertical and horizontal polarization.

In subfreezing conditions, the communications link could fail if an antenna is exposed to ice buildup or covered with snow.

A mast (not provided) must satisfy the following requirements:

- The mast must be constructed of sturdy, weatherproof, noncorrosive material such as galvanized or stainless steel construction pipe.
- Mast diameter should be between 35 mm (1.4 in.) and 42 mm (1.6 in.).
- Antenna mast length must be sufficient to allow an antenna height at least 1.5 meters (5 feet) above the roof peak. If the roof is metal, the antenna height should be a minimum of 3 meters (10 feet) above the roof.



## Antenna Polarization

With RoamAbout outdoor antenna products, it does not matter what type of polarization you choose, as long as the antenna at one end of the communications link is mounted in the same plane as the antenna at the other end.

Radio waves emitting from a Yagi directional antenna are linear, leaving the antenna in the same plane as the antenna elements.

- When the elements are positioned *up and down*, the radio waves are *vertically* polarized.
- When the antenna elements are positioned *left and right*, the radio waves are *horizontally* polarized.

Vertical polarization is standard for the RoamAbout 14 dBi directional antenna.

To minimize the influence of cross-talk between antennas, you might need to mount the antenna for horizontal polarization when:

- Multiple antennas are mounted on the same antenna mast.
- The wireless link transmissions cross another radio beam from a neighboring installation.

### Mounting the Directional Antenna

You can mount the RoamAbout 14 dBi directional antenna on a mast or a flat vertical surface such as a wall. In most cases, mounting the antenna on a mast allows more flexibility in adjusting the height and direction of the antenna in order to better aim it at the opposite end of the wireless link.

The RoamAbout 14 dBi directional antenna kit includes the following hardware:

- A metal backing plate
- Two U-bolts and two clamps
- Four flatwashers and four nuts

**Figure 3-4** illustrates how to mount the RoamAbout 14 dBi directional antenna on a mast. Install the antenna with the arrows on the plastic antenna mounting base pointing up. If using a tripod mount, the antenna mast must be secured to the roof using 3 or 4 guy wires that are equally spaced around the mast. When the height of the antenna mast is more than 3 meters (10 feet), you are advised to use at least three guy wires for each 3 meter (10 foot) section of the mast.

**Figure 3-5** illustrates how to mount the RoamAbout 14 dBi directional antenna on a flat surface. Install the antenna with the arrows on the plastic antenna mounting base pointing up. When mounting the antenna on a flat vertical surface, you must provide a smooth surface for the backing plate. On wall surfaces such as brick, block or stucco, install an intermediate plate between the wall and the backing plate. The intermediate plate must be strong enough to prevent distortion of the backing plate and the plastic antenna mounting base when the mounting hardware is tightened. Make sure that the roof overhang is not excessive and that the location is high enough to provide a clear line of sight.

Both figures illustrate mounting the antenna for *vertical* polarization.

When completed, connect the antenna cables as described in the **“[Connecting the Antenna Cables](#)”** section on page 3-15.

**Figure 3-4: Mounting the 14 dBi Antenna to a Mast**

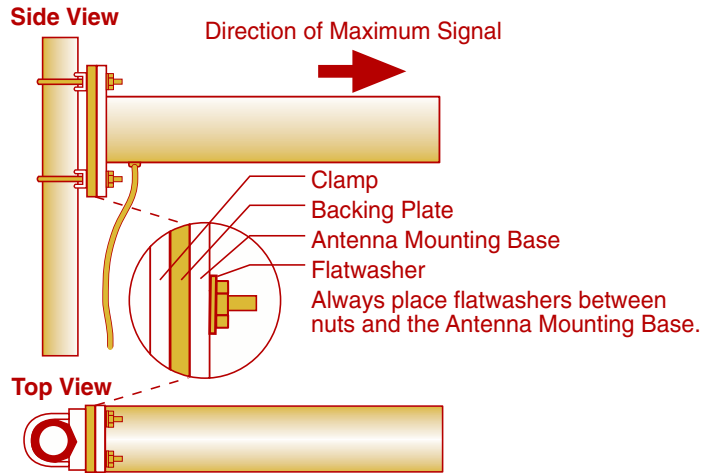

**Figure 3-5: Mounting the 14 dBi Antenna to a Wall**

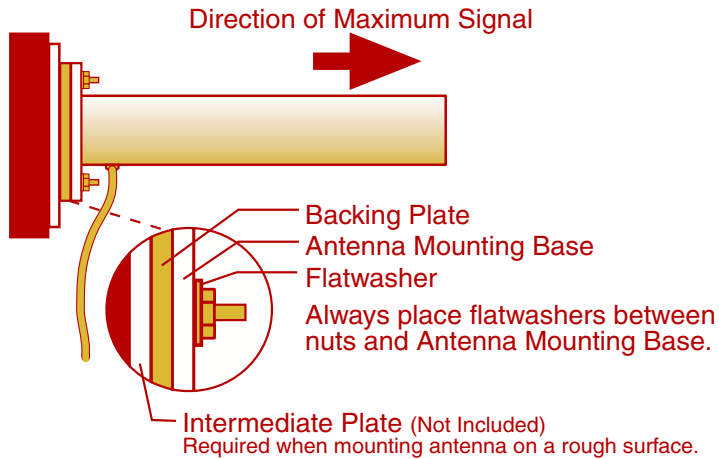

### Mounting the Omni-Directional Antenna

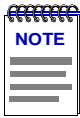

***NOTE:** To avoid signal reflection, you should not install the antenna to the side of a building.*

The RoamAbout 7 dBi omni-directional antenna kit includes a metal backing plate, two hose clamps, and a nut and lockwasher. Refer to [Figure 3-6](#) and perform the following:

1. Insert the threaded portion of the antenna mounting base (A) through the top of the mounting bracket (B).
2. Ensure that the antenna fits snug into the metal mounting bracket by tightening the screw on the mounting bracket (F).
3. Secure the antenna to the metal mounting bracket.
4. Slide the clamp (G) over the mast. Secure both sides of the metal mounting bracket with antenna to the mast (I) using the washer, lockwasher, and nut (H).

Avoid overtightening.

5. Install the washer (C), lock washer (D), and nut (E) to the bottom of the antenna base.
6. Connect the antenna cable (J) to the threaded portion of the antenna mounting base.
7. Connect the antenna cables as described in the [“Connecting the Antenna Cables” section on page 3-15](#).

Figure 3-6: Mounting the Omni-Directional Antenna to a Mast

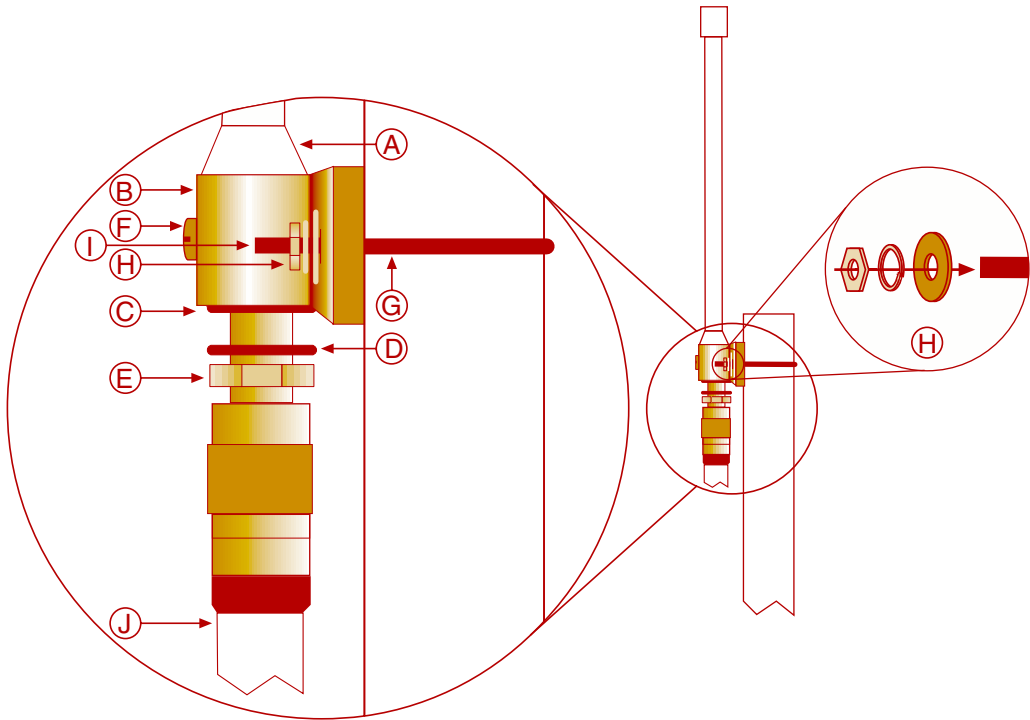

### Mounting the Vehicle-Mount Antenna

The vehicle-mount antenna is typically connected to a client in a wireless infrastructure network. The antenna is mounted to a moving vehicle, such as a fork-lift.

1. Drill a hole in the top of the vehicle so that the antenna connector (at the bottom of the antenna as shown in [Figure 3-7](#)) but not the base fits through the hole. You can also provide and use a bracket to install the antenna to the side of the vehicle.
2. Remove the plastic cap from the connector.
3. Screw the antenna to the top of the base. Finger-tighten only.
4. Install the antenna and base to the vehicle using the hardware provided, as shown in [Figure 3-7](#). Make sure that the gasket is between the antenna base and the vehicle.
5. Use the RoamAbout pigtail connection to connect the antenna to the RoamAbout PC Card in the client.

**Figure 3-7: Mounting the Vehicle-Mount Antenna**

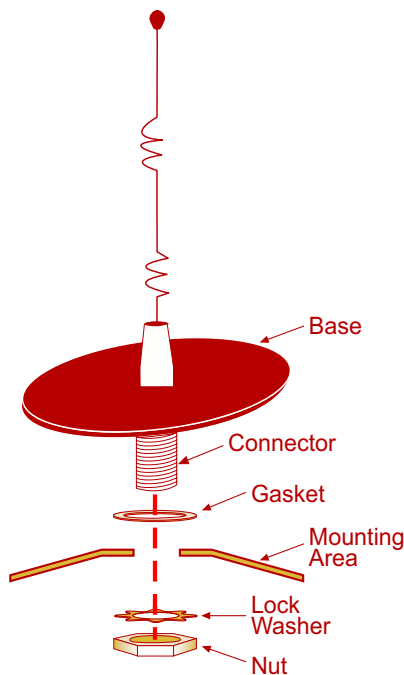

## ting

connect

the fol

Room

Room

Low-

Outd

Pigt

Do

Do

Do

Do

Do

Do

Do

Do

Do

Do

Do

Do

Do

Do

Do

Do

Do

Do

Do

Do

Do

Do

Do

Do

Do

Do

Do

Do

Do

Do

Do

Do

Do

Do

**NOTE:** Shortening the antenna cables voids the warranty and may conflict with radio certifications and/or approvals.

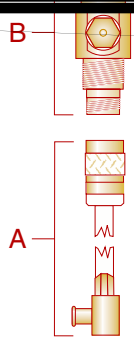

The cable should not be installed into tight positions, as bending or applying excessive force to the connectors may damage the antenna cable. Always allow the cable to bend naturally around corners. The recommended bend radius is 25 mm (1 in.).

Low-loss antenna cable must be secured along its complete length. No part of the cable should be allowed to hang free. This is particularly important for cable that are installed outdoors. The antenna cables and cable connectors are not designed to withstand excessive force:

Do not use connectors as cable grips to pull cable through raceways or conduits.

Do not use cable connectors to support the weight of the cable during or after installation.

Do not use tools to tighten connectors (finger-tighten only).

### Connecting the Cables

Once the antenna is properly installed, you can connect the antenna to the RoamAbout AP via the RoamAbout Lightning Protector.

1. Verify that the low-loss antenna cable is properly connected to the antenna cable.
2. Secure the low-loss cable to the mast such that the cable connectors do not support the full weight of the cable.
3. Provide a drip-loop at the bottom of the low-loss cable just before it enters the building.
4. Connect the opposite end of the low-loss cable to the RoamAbout Lightning Protector.



**CAUTION:** To avoid damage to the antenna cable and connectors, do not use tools to tighten cable connectors.

5. Prior to securing the cable along its complete length, use the RoamAbout AP Manager program to analyze wireless performance and optimal placement of the outdoor antenna as described in the **“Optimizing RoamAbout Outdoor Antenna Placement” section on page 3-17**. If required, adjust the direction of the antenna.
6. Once the installation has been fully tested, tighten antenna mounting nuts to lock the antenna into its position.



**CAUTION:** To prevent damage, avoid overtightening the connectors, nuts, and screws used to mount the antenna.

7. Secure the cable along its complete length. No part of the cable should be allowed to hang free.
8. Use waterproof stretch tape to seal all outdoor connectors.



## Optimizing RoamAbout Outdoor Antenna Placement

If an AP is connected to an outdoor directional antenna, the antenna must be pointed directly at the antenna for the other AP. A misaligned antenna can decrease the signal level or prevent communications. Aligning an omni-directional antenna is less critical due to its wide radiation pattern. For optimal performance, make sure the antennas are properly aligned:

- Use a pair of binoculars to point the antennas at each other.
- Analyze the quality of the radio link using the RoamAbout AP Manager.

The RoamAbout AP Manager provides a Link Test diagnostic tool that can help you adjust the directional antenna to optimize the signal between APs. To test the link between two APs that both use directional antennas, you may need one person at each antenna and a method to communicate with those people. For details on installing and using the AP Manager, refer to the *RoamAbout 802.11 Wireless Networking Guide*.

To run the Link Test tool, perform the following steps:

1. There are two ways to access the Link Test window:

fields highlighted by (a2(e).8(s:)]T(e)-7.6e.6145 0 2(oum)-4-4.TJl)-1Tc04.3(e)-7(IJ17.614

## Routine Maintenance

Routine maintenance is required for each RoamAbout Lightning Protector in your outdoor antenna installation. Maintenance involves replacing the Gas Discharge Tube (GDT) at some interval depending on the lightning/transient discharge activity in your area.

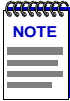

***NOTE:*** Contact a local antenna installation company to determine the maintenance schedule for each RoamAbout Lightning Protector in your outdoor antenna installation.

# Appendix A

---

## Specifications

---

This appendix lists the specifications of the various RoamAbout outdoor antenna products.

### RoamAbout 14 dBi Directional Antenna

The directional antenna is a totally enclosed 16-element Yagi designed for point-to-point communications. The antenna is normally mounted on a mast and vertically polarized.

**Table A-1: 14 dBi Directional Antenna Specifications**

<b>Mechanical</b>	
• Size	45.7 cm (18 in.)
• Mounting Method	<ul style="list-style-type: none"><li>• Vertical mast with an outside diameter between 35 mm (1.4 in.) and 42 mm (1.6 in.) using u-bolts.</li><li>• Wall using plugs and screws.</li></ul>
<b>Cable</b>	
• Type	RG-58A/U, 50 ohm low-loss coax
• Length	31 1/4 in. (+/- 1 in.)
• Color	White
<b>Connector Type (Access Point 2000)</b>	
• FCC Countries	Reverse Polarity-N (Male)
• ETSI Countries: France, Japan, Asia Pacific	Standard-N (Female)
<b>Connector Type (RoamAbout R2)</b>	
• FCC Countries	Standard-N (Female)
• ETSI Countries: France, Japan, Asia Pacific	Standard-N (Female)

## RoamAbout 14 dBi Directional Antenna

---

<b>Electrical</b>	
• Frequency Range	2.4 GHz
• VSWR	Less than 2:1, 1.5:1 Nominal
• Nominal Impedance	50 Ohms
• Gain	14 dBi
• Front-to-Back Ratio	greater than 20 dB
• Half-Power Beamwidth	(-3dB)
• Vertical (E-plane °)	30.8 Degrees
• Horizontal (H-plane °)	31.4 Degrees
• Polarization	Linear, Vertical or Horizontal

<b>Antenna Environment</b>	
• Operating Temperature	- 40°C to +60°C (-40°F to 140°F)
• Wind/survival (mph)	At least 128 km/h (80 mph) <sup>1</sup>
• Wind Surface Area	7.56 square cm (0.248 square feet)

<sup>1</sup> At least 104 km/h (65 mph) with 1.25 cm (0.5 in.) ice.

## RoamAbout 7 dBi Omni-Directional Antenna

The RoamAbout omni-directional antenna is a broadband antenna for the 2.4 GHz frequency band featuring an omni-directional pattern with a nominal gain of 7 dBi.

This antenna is encapsulated in a weatherproof protective covering. With the hardware provided, this vertically-polarized antenna can be mounted on an antenna mast with an outside diameter of up to 51 mm (2 in.). The table below provides the antenna specifications.

**Table A-2: 7 dBi Omni-Directional Antenna Specifications**

<b>Mechanical</b>	
• Size	45.7 cm (18 in.)
• Mounting method	Clamps to vertical mast with outside diameter up to 51 mm (2 in.)
<b>Cable - None</b>	
<b>Connector Type (Access Point 2000)</b>	
• FCC Countries	Reverse Polarity-N (male)
• ETSI Countries: France, Japan, Asia Pacific	Standard-N (female)
<b>Connector Type (RoamAbout R2)</b>	
• FCC Countries	Standard-N (Female)
• ETSI Countries: France, Japan, Asia Pacific	Standard-N (Female)
<b>Electrical</b>	
• Frequency Range	2.4 GHz
• VSWR	Less than 2:1 Nominal
• Nominal Impedance	50 Ohms
• Gain	7 dBi
• Polarization	Linear Vertical
<b>Antenna Environment</b>	
• Operating Temperature	- 40°C to +60°C (-40°F to 140°F)
• Wind/survival (mph)	At least 128 km/h (80 mph) <sup>1</sup>
• Wind Surface Area	7.56 square cm (0.248 square feet)

<sup>1</sup> At least 104 km/h (65 mph) with 1.25 cm (0.5 in.) ice.

## Vehicle-Mount Antenna

The RoamAbout vehicle-mount antenna can be mounted on vehicles, such as fork-lift trucks, that need continuous access to networked data whether inside or outside of the building. The following table provides the specifications for the vehicle-mount antenna.

**Table A-3: Vehicle-Mount Antenna Specifications**

<b>Mechanical</b>	
<b>Connector Type (Access Point 2000)</b>	
• FCC Countries	Reverse Polarity-N (Male)
• ETSI Countries: France, Japan, Asia Pacific	Standard-N (Female)
<b>Connector Type (RoamAbout R2)</b>	
• FCC Countries	Standard-N (Female)
• ETSI Countries: France, Japan, Asia Pacific	Standard-N (Female)
<b>Electrical</b>	
• Frequency Range	2400-2438 MHz
• VSWR (Voltage Standing Wave Ratio)	1.5:1
• Nominal Impedance	50 Ohms
• Gain	5 dBi
• Half-Power Beamwidth	NA
• Polarization	Vertical
• Power Handling	100 Watts
<b>Antenna Environment</b>	
• Operating Temperature	- 40°C to +60°C (-40°F to 140°F)
• Relative Humidity Range	0-100%
• Wind/survival (mph)	194 km/h (120 mph) <sup>1</sup>
• Wind rating	129 km/h (80 mph)
• Wind load	202 km/h (125 mph)

<sup>1</sup> 104 km/h (65 mph) with 1.25 cm (0.5 in.) ice.

## RoamAbout Pigtail Connection

The RoamAbout Pigtail Connection is a proprietary cable used to connect the RoamAbout PC Card to a RoamAbout outdoor antenna system.

One end of the cable has a proprietary connector which is connected to the RoamAbout PC Card. The N-Type connector at the opposite end of the cable matches the polarity of the N-connectors of the other components that are part of your outdoor antenna cabling system, subject to the country where the RoamAbout Pigtail Connection was purchased.

**Table A-4: Pigtail Connection Specifications**

<b>Mechanical</b>	
<b>Length</b>	50 cm (19.5 in.)
<b>Connector Type (Access Point 2000)</b>	
• FCC Countries	Reverse Polarity-N (Female)
• ETSI Countries: France, Japan, Asia Pacific	Standard-N (Male)
<b>Connector Type (RoamAbout R2)</b>	
• FCC Countries	Standard-N (Male)
• ETSI Countries: France, Japan, Asia Pacific	Standard-N (Male)
<b>Operating Temperature</b>	-40°C to +85°C (-40°F to +185°F)
<b>Electrical</b>	
• Frequency Range	800-2500 MHz
• Insertion Loss	0.9 dB

## Low-Loss Antenna Cable

The RoamAbout low-loss cable is available in the following standard lengths:

- 15 meters (50 feet) - see Table A-5
- 22 meters (75 feet) - see Table A-6

To ensure you order the right cable length, carefully determine the distance between the locations where you intend to mount the RoamAbout AP and outdoor antenna.

**Table A-5: Cable Specifications for the 15 Meter (50 Foot) Antenna**

<b>Mechanical Specifications</b>	
• Length	15 meter (50 ft)
• Diameter	10 mm (0.4 in.)
• Weight	101.2 gram/meter (0.068 lbs/ft)
• Bend Radius	25 mm (1 in.)
<b>Connector Type (Access Point 2000)</b>	
• FCC Countries	Reverse Polarity-N (Female on both ends)
• ETSI Countries: France, Japan, Asia Pacific	Standard-N (Male on both ends)
<b>Connector Type (RoamAbout R2)</b>	
• FCC Countries	Standard-N (Male on both ends)
• ETSI Countries: France, Japan, Asia Pacific	Standard-N (Male on both ends)
<b>Operating Temperature</b> -40°C to +85°C (-40°F to +185°F)	
<b>Electrical Specifications</b>	
• Insertion Loss	0.22 dB/meter (6.8 dB/100 feet)
• Total for this cable	3.5 dB



**Table A-6: Cable Specifications for the 22 Meter (75 Foot) Antenna**

<b>Mechanical Specifications</b>	
• Length	22 meter (75 ft)
• Diameter	10 mm (0.4 in.)
• Weight	101.2 gram/meter (0.068 lbs/ft)
• Bend Radius	25 mm (1 in.)
<b>Connector Type (Access Point 2000)</b>	
• FCC Countries	Reverse Polarity-N (Female on both ends)
• ETSI Countries: France, Japan, Asia Pacific	Standard-N (Male on both ends)
<b>Connector Type (RoamAbout R2)</b>	
• FCC Countries	Standard-N (Male on both ends)
• ETSI Countries: France, Japan, Asia Pacific	Standard-N (Male on both ends)
<b>Operating Temperature</b> -40°C to +85°C (-40°F to +185°F)	
<b>Electrical Specifications</b>	
• Insertion Loss	0.22 dB/meter (6.8 dB/100 feet)
• Total for this cable	5.1 dB

## RoamAbout Lightning Protector

The RoamAbout Lightning Protector is a surge arrestor that protects your sensitive RoamAbout equipment from high-voltage currents caused by discharge and transients at the antennas.

Table A-7 lists the specifications for the RoamAbout Lightning Protector.

**Table A-7: Lightning Protector Specifications**

<b>Mechanical</b>	
<b>Size</b>	
• Height	69 mm (2.7 in.)
• Diameter	26 mm (1 in.)
• Weight	133 g (4.7 oz.)
<b>Connector Type (Access Point 2000)</b>	
• FCC Countries	Reverse Polarity-N (Male on both ends)
• ETSI Countries: France, Japan, Asia Pacific	Standard-N (Female on both ends)
<b>Connector Type (RoamAbout R2)</b>	
• FCC Countries	Standard-N (Female on both ends)
• ETSI Countries: France, Japan, Asia Pacific	Standard-N (Female on both ends)
<b>Operating Temperature</b> -40°C to +85°C (-40°F to +185°F)	
<b>Electrical</b>	
• Frequency Range	800-2500 MHz
• Insertion Loss	0.2 dB
• Surge Current	2000 Amp
• Nominal Impedance	50 Ohms