



TYS SERIES

3-PHASE, 4-WIRE FILTERS

COMPONENTS

PART NO.	C1 (uF)	C2 (uF)	Lg (uH)	L (mH)	R (KΩ)
20TYS10	2.0	1.0	78	3.2	110
• 30TYS10			52	1.6	
60TYS10			52	0.32	

• UL, CSA & SEMKO approved C3: 3300pF C4: 14700pF

INTRODUCTIONS

1. Applications: Electric equipment, UPS, machine tool, copy machine, automation equipment, robot, AC motor drive
2. Voltage rating: 440VAC
3. Operating frequency: 50/60Hz

MINIMUM INSERTION LOSS IN dB

COMMON MODE (L-G) IN 50 OHM SYSTEM							
TYPE	CURRENT RATING	FREQUENCY - MHz					
		.15	.50	1.0	5.0	10	30
20TYS10	20A	25	40	35	30	30	30
30TYS10	30A	25	40	40	45	45	35
60TYS10	60A	15	30	30	30	30	30
DIFFERENTIAL MODE (L-L) IN 50 OHM SYSTEM							
20TYS10	20A	35	35	35	30	30	30
30TYS10	30A	40	55	55	45	45	40
60TYS10	60A	18	45	45	35	35	30

ELECTRICAL SCHEMATIC

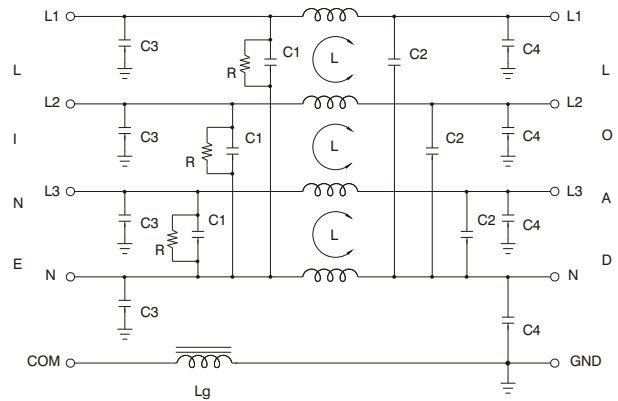

SERIES

DIM. TYPE	A	B	C	D	E	F	G	H	I	J	K
20TYS10	5.59 142.0	4.606 117.0	0.98 25.0	8.85 225.0	6.57 167.0	7.75 197.0	2.55 65.0	1.496 38.0	0.51 13.0	1.81 46.0	0.88 22.4
30TYS10											
60TYS10											

MECHANICAL CONSTRUCTION

Optional mounting Flange:

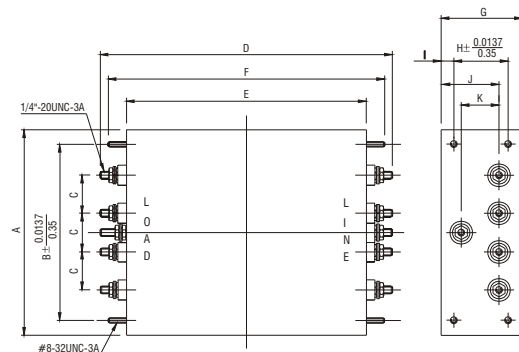
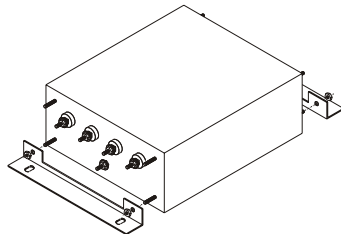
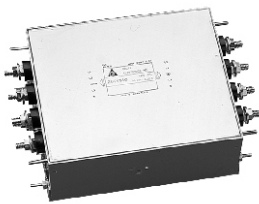

UNIT: INCH
mm

THREE-PHASE FILTERS



TYS SERIES

HIGH CURRENT 3-PHASE, 4-WIRE FILTERS

COMPONENTS

PART NO.	Cx(uF)	Cy(uF)	L(uH)	R1(KΩ)	R1(MΩ)
200TYSS104	4.7	2.2	3.0	470	1M
300TYSS104	10.0				
400TYSS104	12.2				
500TYSS104	14.7	4.7			
600TYSS104	20.0				

MINIMUM INSERTION LOSS IN dB

COMMON MODE (L-G) IN 50 OHM SYSTEM									
PART Number	FREQUENCY-MHz								
	.01	.05	.10	.15	.50	1.0	5.0	10	30
200TYSS104	5	15	20	20	30	30	15	10	5
300TYSS104	10	25	30	30	35	30	20	15	10
400TYSS104	10	25	30	30	30	20	10	10	5
500TYSS104	5	10	25	25	30	25	15	10	5
600TYSS104	5	10	25	25	35	30	15	10	5

DIFFERENTIAL MODE (L-L) IN 50 OHM SYSTEM									
PART Number	FREQUENCY-MHz								
	.01	.05	.10	.15	.50	1.0	5.0	10	30
200TYSS104	10	20	40	40	35	25	15	10	5
300TYSS104	25	35	35	35	35	30	20	15	10
400TYSS104	25	35	35	30	30	25	10	10	5
500TYSS104	20	20	40	40	30	25	15	10	5
600TYSS104	20	20	40	40	35	30	15	10	5

SERIES DIMENSIONS

PART number	DIMENSIONS IN INCHES/mm														
	A	B	C	D	E	F	G	H	I	J	K	L	M	N	
200TYSS104	20.669	18.800	15.827	9.528	5.591	17.717	2.362	2.765	0.256x0.315	0.118	Ø0.236	0.591	1.772	M8x1.2	
300TYSS104	525.0	477.0	402.0	242.0	142.0	450.0	60.0	70.0	6.5x8.0	3.0	Ø6.0	15.0	45.0		
400TYSS104															
500TYSS104	26.772	22.520	19.764	10.709	7.165	21.457	2.953	2.953	0.295x0.374	0.236	Ø0.295	0.591	2.165	M12x11.7	
600TYSS104	680.0	572.0	502.0	272.0	182.0	545.0	75.0	75.0	7.5x9.5	6.0	Ø7.5	15.0	55.0		

MECHANICAL CONSTRUCTION



INTRODUCTIONS

1. Applications: Electric equipment, UPS, machine tool, copy machine, automation equipment, robot, AC motor drive
2. Voltage rating: 480VAC
3. Operating frequency: 50/60Hz

ELECTRICAL SCHEMATIC

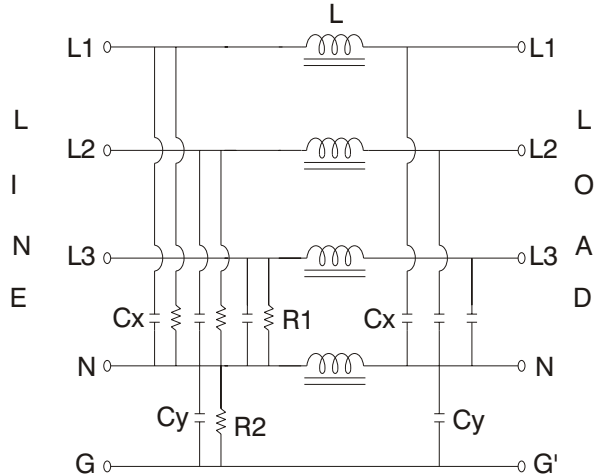

200~400A

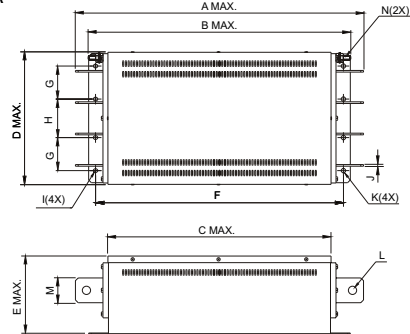

500~600A

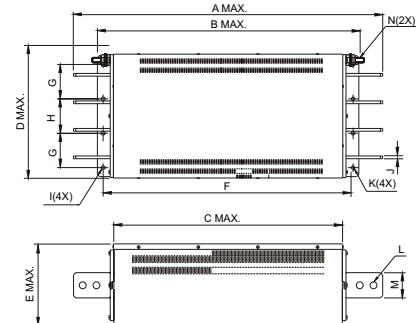

UNIT: INCH/mm