



RTU-DNET

DeviceNet Remote I/O Communication Module

Application Manual



<http://www.delta.com.tw/industrialautomation>



Warning

- ✓ Please read this instruction carefully before use and follow this instruction to operate the device in order to prevent damages on the device or injuries to staff.
- ✓ Switch off the power before wiring.
- ✓ RTU-DNET is an OPEN TYPE device and therefore should be installed in an enclosure free of airborne dust, humidity, electric shock and vibration. The enclosure should prevent non-maintenance staff from operating the device (e.g. key or specific tools are required for operating the enclosure) in case danger and damage on the device may occur.
- ✓ RTU-DNET is to be used for controlling the operating machine and equipment. In order not to damage it, only qualified professional staff familiar with the structure and operation of RTU-DNET can install, operate, wire and maintain it.
- ✓ DO NOT connect input AC power supply to any of the I/O terminals; otherwise serious damage may occur. Check all the wirings again before switching on the power and DO NOT touch any terminal when the power is switched on. Make sure the ground terminal ⊕ is correctly grounded in order to prevent electromagnetic interference.



Table of Contents

1	INTRODUCTION	3
1.1	Features	3
1.2	Functions.....	3
1.3	Specifications	3
1.4	Extension Modules Connectable to RTU-DNET	4
2	PRODUCT PROFILE & OUTLINE	5
2.1	Dimension	5
2.2	Product Profiles	5
2.3	DeviceNet Connection Port.....	6
2.4	RUN/STOP Switch	6
2.5	Address Switch	6
2.6	Function Switch.....	6
2.7	Extension Port.....	7
3	BASIC OPERATION.....	7
3.1	Connecting RTU-DNET to DVP Slim DI/DO Extension Unit	7
3.2	Installing RTU-DNET and DVP Slim DI/DO on DIN Rail	7
3.3	Connecting to DeviceNet Connection Port.....	8
4	HOW TO CONFIGURE RTU-DNET	8
4.1	Terms	8
4.2	Format of Request Message and Response Message.....	9

4.3	DeviceNet I/O Mapping Data	14
4.4	Example.....	17
5	HOW TO CONSTRUCT A DEVICENET NETWORK USING RTU-DNET	22
5.1	How to Construct DeviceNet by RTU-DNET	22
5.2	How to Configure Network by DeviceNet Network Configuration Tool	22
6	LED INDICATOR & TROUBLE-SHOOTING	31
6.1	POWER LED	31
6.2	NS LED.....	31
6.3	MS LED	31
6.4	ALARM LED	31
6.5	RUN LED.....	32

1 Introduction

1. To ensure correct installation and operation of RTU-DNET, please read this chapter carefully before using your RTU-DNET.
2. This chapter only provides introductory information on RTU-DNET. For more detailed information on DeviceNet protocol, please refer to relevant references or literatures.
3. RTU-DNET is a remote I/O communication module applicable to the connection between DeviceNet and DVP Slim DIDO module and special modules. RTU-DNET offers functions such as status diagnosis, error treatment and so on.

1.1 Features

- Supports Group 2 only servers.
- Supports explicit connection via predefined Master/Slave connection set.
- Supports polling
- Supports EDS file configuration in DeviceNet network configuration tools.
- Max. 256 digital I/O points extendable.
- Max. 8 special modules extendable.

1.2 Functions

Item	Explanation
Graphic configuration interface	RTU-DNET supports graphic configuration interface in DeviceNet network configuration tools.
Data retention	The user can choose either to retain or give up the data in the register when RTU-DNET is offline.
Auto extension module identification	The user can automatically identify the special module or the enumber of points on the DVP Slim DI/DO extension unit connected to RTU-DNET through DeviceNet network configuration tool.
Diagnosis	RTU-DNET is able to diagnose the status of the special module connected to it. When an error occurs, The ALARM LED on RTU-DNET will flash in red.
Status inquiry	RTU-DNET is able to inquire the connection status between itself and the extension module in DeviceNet network configuration tool.
Error inquiry	The user can read the error through DeviceNet network configuration tool.
Error treatment	The user can choose a method to correct the error through DeviceNet network configuration tool.
Flexible configuration	The user can configure the control register (CR) in the special module in any way as the I/O mapping data for DeviceNet.

1.3 Specifications

■ DeviceNet connection

Transmission method	CAN
Electrical isolation	500 VDC
Interface	Removable connector (5.08mm)
Transmission cable	2-wire twister shielded cable with 2-wire bus power and drain

■ Communication

Message type	I/O polling, explicit
--------------	-----------------------

Baud rates	125 kbps; 250 kbps; 500 kbps
------------	------------------------------

■ Electrical specification

Voltage	11 ~ 25 VDC, supplied by internal bus from PLC MPU
Current	28mA (typical), 125mA impulse current (24 VDC)

■ Environment

Noise immunity	ESD (IEC 61131-2, IEC 61000-4-2): 8KV Air Discharge EFT (IEC 61131-2, IEC 61000-4-4): Power Line: 2KV, Digital I/O: 1KV Analog & Communication I/O: 1KV Damped-Oscillatory Wave: Power Line: 1KV, Digital I/O: 1KV RS (IEC 61131-2, IEC 61000-4-3): 26MHz ~ 1GHz, 10V/m
Operation	0°C ~ 55°C (temperature); 50 ~ 95% (humidity); pollution degree 2
Storage	-25°C ~ 70°C (temperature); 5 ~ 95% (humidity)
Vibration/shock resistance	Standard: IEC 61131-2, IEC 68-2-6 (TEST Fc)/IEC 61131-2 & IEC 68-2-27 (TEST Ea)
Certificates	IEC 61131-2, UL508

1.4 Extension Modules Connectable to RTU-DNET

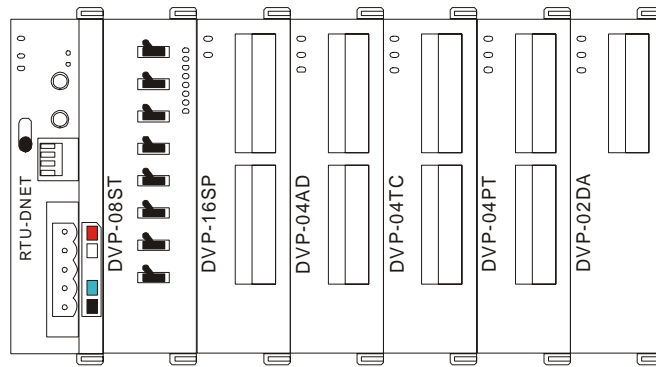

■ DVP Slim DI/DO extension units connectable to RTU-DNET

Slim DI/DO (model name)	I/O mapping data (DeviceNet → RTU-DNET)	I/O mapping data (RTU-DNET → DeviceNet)
DVP-08SM11N	N/A	8 bits
DVP-08SN11R/T	8 bits	N/A
DVP-08SP11R/T	8 bits	8 bits
DVP-16SP11R/T	8 bits	8 bits
DVP-08ST	N/A	8 bits

■ Special modules connectable to RTU-DNET

Special module (model name)	Default I/O mapping data (DeviceNet → RTU-DNET)		I/O mapping data (RTU-DNET → DeviceNet)	
	Start CR	Length (words)	Start CR	Length (words)
DVP-02DA	CR#10	2	N/A	N/A
DVP-04DA	CR#6	4	N/A	N/A
DVP-04AD	N/A	N/A	CR#12	4
DVP-06AD	N/A	N/A	CR#12	6

Special module (model name)	Default I/O mapping data (DeviceNet → RTU-DNET)		I/O mapping data (RTU-DNET → DeviceNet)	
	Start CR	Length (words)	Start CR	Length (words)
DVP-04TC	N/A	N/A	CR#14	4
DVP-04PT	N/A	N/A	CR#18	4
DVP-06XA	CR#10	2	CR#12	4
DVP-01PU	CR#42	4	CR#33	4

Note:

While connected to a special module, the start CR and length of upload/download data of RTU-DNET can be set up in DeviceNet network configuration tool.

2 Product Profile & Outline

2.1 Dimension

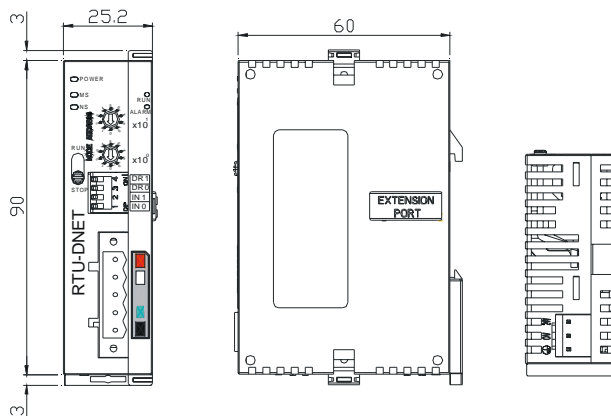

2.2 Product Profiles

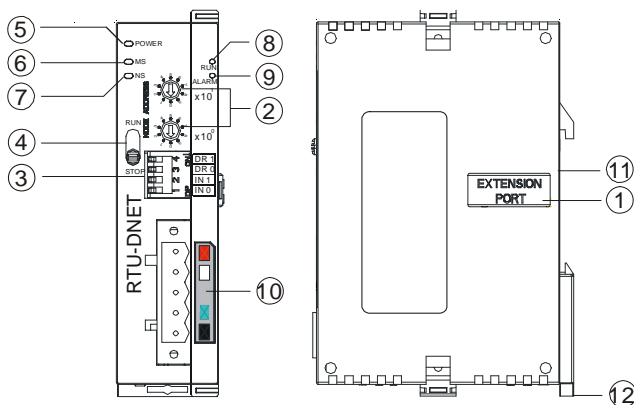

1. Extension port	7. NS (Network Status) indicator
2. Address switch	8. RUN indicator
3. Function switch	9. ALARM indicator
4. RUN/STOP switch	10. DeviceNet connection port
5. POWER indicator	11. DIN rail
6. MS (Module Status) indicator	12. DIN rail clip

2.3 DeviceNet Connection Port

The connector is used on the connection to DeviceNet. Wire by using the connector enclosed with RTU-DNET.

PIN	Signal	Color	Content
1	V-	Black	0 VDC
2	CAN_L	Blue	Signal-
3	SHIELD	-	Shielded
4	CAN_H	White	Signal+
5	V+	Red	24 VDC

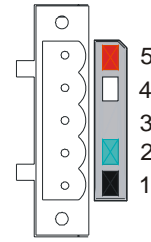

2.4 RUN/STOP Switch

RUN/STOP action	Explanation
STOP → RUN	1. Re-detecting the extension module. 2. Reading/writing the data in the extension module.
RUN → STOP	Stop reading/writing the data in the extension module.

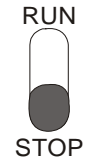

2.5 Address Switch

The switch is used on setting up the node address of RTU-DNET on DeviceNet. Range: 00 ~ 63 (64 ~ 99 are forbidden).

Switch setting	Content
0 ~ 63	Valid DeviceNet node address
64 ~ 99	Invalid DeviceNet node address

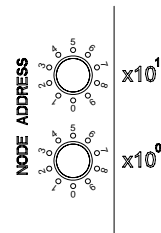

Example: If you need to set the node address of RTU-DNET to 26, simply switch the corresponding switch of $x10^1$ to 2 and the corresponding switch of $x10^0$ to 6.

Note:

- Please set up the node address when the power is switched off. After the setup is completed, re-power RTU-DNET.
- When RTU-DNET is operating, changing the setting of node address will be invalid.
- Use slotted screwdriver to rotate the switch carefully in case you scratch the switch.

2.6 Function Switch

The function switches are for:

- Setting up data retention function (IN0)
- Setting up the baud rate of DeviceNet (DR0 ~ DR1)

DR1	DR0	Baud rate
OFF	OFF	125 kbps
OFF	ON	250 kbps
ON	OFF	500 kbps
ON	ON	Incorrect setting

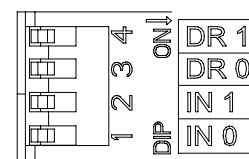

IN0	OFF	When DeviceNet is off, the I/O data in the buffer area will be cleared.
	ON	When DeviceNet is off, the I/O data in the buffer area will be held.
IN1	Reserved	

Note:

- Please set up the function switch when the power is switched off. After the setup is completed, re-power RTU-DNET.
- When RTU-DNET is operating, changing the setting of the function switch will be invalid.
- Use slotted screwdriver to adjust the DIP switch carefully in case you scratch the switch.

2.7 Extension Port

The extension port is used on connecting RTU-DNET to DVP Slim DI/DO extension units and special modules.

3 Basic Operation

3.1 Connecting RTU-DNET to DVP Slim DI/DO Extension Unit

- Open the fixing clips on top and bottom of RTU-DNET. Meet the extension port of Slim DI/DO with RTU-DNET.
- Press the fixing clips on top and bottom of Slim DI/DO and check if the connection is fine.

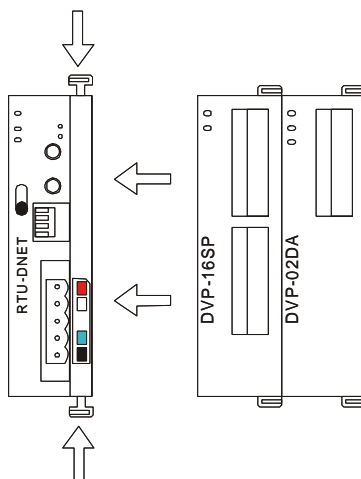

3.2 Installing RTU-DNET and DVP Slim DI/DO on DIN Rail

- Use 35mm DIN rail.
- Open the DIN rail clip on RTU-DNET and Slim DI/DO. Insert RTU-DNET and Slim DI/DO onto the DIN rail.
- Clip up the DIN rail clips on RTU-DNET and Slim DI/DO to fix them on the DIN rail, as shown below.

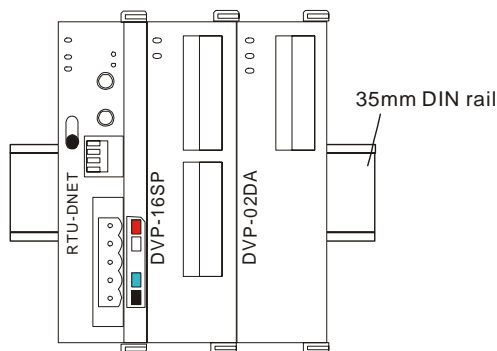

3.3 Connecting to DeviceNet Connection Port

- The colors on the PINs on the DeviceNet connection port match the colors of the connection cables. Make sure you connect the cable to the right PIN.
- We recommend you also apply Delta's power module in the connection.

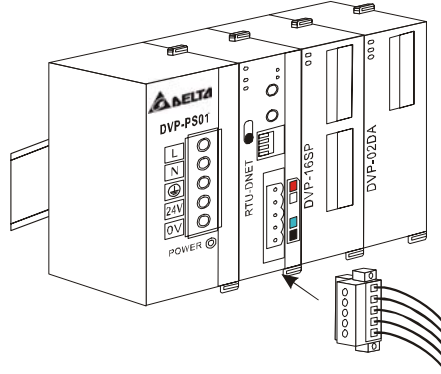

4 How to Configure RTU-DNET

In this section we will introduce how RTU-DNET as a DeviceNet slave realizes the data exchange between DeviceNet master and DVP Slim DI/DO extension unit.

- DeviceNet master sends the data to Slim DI/DO.
- RTU-DNET sends the input data from Slim DI/DO to DeviceNet master.

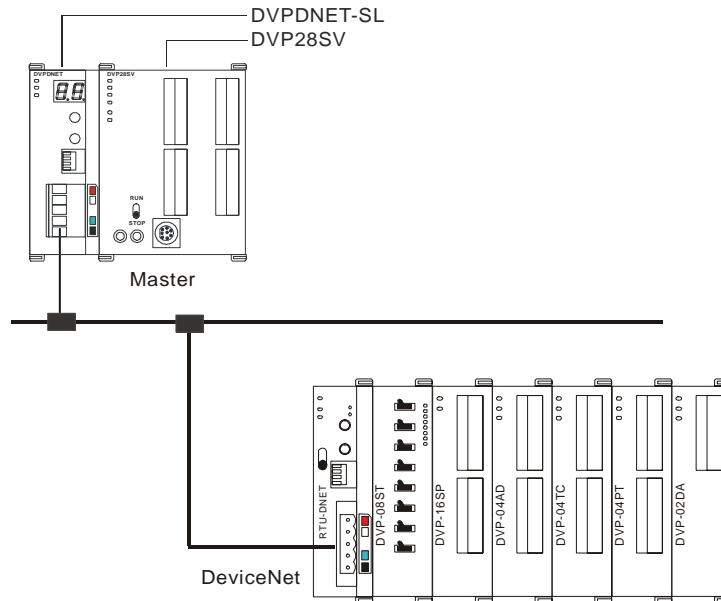

4.1 Terms

No.	Item	Unit	Explanation
1	Control word	Word	For setting up the mode of RTU-DNET, e.g. "H8000" for STOP mode and "H8001" for RUN mode. See 4.3 for more details.
2	Status word	Word	Displaying the status of RTU-DNET. See 4.3 for more details.
3	Number of digital input points	Bit	The digital input points shall be 8's multiple. The number will be regarded as 8 when it is less than 8 and as 16 when it is bigger than 8 but less than 16.
4	Number of digital output points	Bit	The digital output points shall be 8's multiple. The number will be regarded as 8 when it is less than 8 and as 16 when it is bigger than 8 but less than 16.

No.	Item	Unit	Explanation
5	Length of input data of special module	Word	The length of input data of the special module connected to RTU-DNET
6	Length of output data of special module	Word	The length of output data of the special module connected to RTU-DNET
7	Length of input I/O data	Byte	The sum of the length of the status word of RTU-DNET and the input data of the special module connected to it. One input channel of the special module occupies 2 bytes. 8 points of the digital input are counted as 1 byte.
8	Length of output I/O data	Byte	The sum of the length of the control word of RTU-DNET and the output data of the special module connected to it. One output channel of the special module occupies 2 bytes. 8 points of the digital output are counted as 1 byte.
9	Number of special modules	Unit	The number of special modules connected to RTU-DNET. Range: 0 ~ 8
10	Diagnostic interval time	Sec	The interval when RTU-DNET executes diagnosis. Range: 1 ~ 65, Default: 5 secs
11	Special module offline treatment	N/A	How RTU-DNET will react when the special module connected to it is offline. You can choose "Ignored", "Alarm" or "Stop DeviceNet IO". Default: Alarm
12	Special module error treatment	N/A	How RTU-DNET will react when it detects errors. You can choose "Ignored", "Alarm" or "Stop DeviceNet IO". Default: Alarm
13	Reset RTU-DNET	N/A	Reset the configuration of RTU-DNET to default settings.
14	Add control word and status word to I/O data	N/A	For you to decide whether to add control word and status word to I/O data. When you choose not to do it, the I/O data in RTU-DNET and DeviceNet master will not include control word and status word. If you choose to add them in, the I/O data in RTU-DNET and DeviceNet master will include control word and status word.
15	Work mode	N/A	For you to set up the work mode of the special module connected to RTU-DNET. When set to "auto mode", RTU-DNET will configure default CR of the special module as DeviceNet I/O mapping data. When set to "custom mode", you can configure any CR in the special module as DeviceNet I/O mapping data.
16	Number of input data connected	---	The number of input data of the special module connected to RTU-DNET
17	Number of output data connected	---	The number of output data of the special module connected to RTU-DNET
18	Length of input data	Word	The sum of the length of input data of the special modules connected to RTU-DNET
19	Length of output data	Word	The sum of the length of output data of the special modules connected to RTU-DNET
20	I/O mapping	N/A	The I/O mapping relation between RTU-DNET and the special module connected to it

4.2 Format of Request Message and Response Message

1. RTU-DNET supports using DeviceNet explicit messages to poll special modules.

■ Format of request messages

Byte position	Data written into special module	Data read from special module
0	Frag[0]+XID+MAC ID	Frag[0]+XID+MAC ID

Byte position	Data written into special module	Data read from special module
1	R/R[0]+Service Code[0x10]	R/R[0]+Service Code[0x0E]
2	Class ID [0x9C]	Class ID [0x9C]
3	Instance ID	Instance ID
4	Attribute ID	Attribute ID
5	Low byte of Service Data	N/A
6	High byte of Service Data	N/A
7	N/A	N/A

■ Format of response messages

Byte position	Data written into special module	Data read from special module
0	Frag[0]+XID+MAC ID	Frag[0]+XID+MAC ID
1	R/R[1]+Service Code[0x10]	R/R[1]+Service Code[0x0E]
2		Low byte of response data
3		High byte of response data

2. Definitions of DeviceNet Objects for RTU-DNET

■ Class 0x9A – RTU-DNET setup parameter object

Class attribute

Attribute ID	Access rule	Name	Data type
1	Get	Revision	UINT

Instance 1

Attribute ID	Access rule	Name	Range	Default	Explanation
1	Get	Length of input I/O data	N/A	N/A	The sum of the length of the status word of RTU-DNET and the input data of the module connected to it. (Unit: byte)
2	Get	Length of output I/O data	N/A	N/A	The sum of the length of the control word of RTU-DNET and the output data of the module connected to it. (Unit: byte)
3	Get	Number of digital input points (X)	0 ~ 128	N/A	The number will be regarded as 8 when it is less than 8 and as 16 when it is bigger than 8 but less than 16. (Unit: bit)
4	Get	Number of digital output points (Y)	0 ~ 128	N/A	The number will be regarded as 8 when it is less than 8 and as 16 when it is bigger than 8 but less than 16. (Unit: bit)
5	Get	Number of special modules	0 ~ 8	N/A	The number of special modules connected to RTU-DNET.
6	Get	Length of analog input	N/A	N/A	The length of input data of the special module connected to RTU-DNET. (Unit: word)
7	Get	Length of analog output	N/A	N/A	The length of output data of the special module connected to RTU-DNET. (Unit: word)

Attribute ID	Access rule	Name	Range	Default	Explanation
8	Get	Status word	0~255	N/A	Displaying the status of RTU-DNET. See 4.3 for more details.
9	Get/Set	Control word	N/A	N/A	For setting up the mode of RTU-DNET, e.g. "H8000" for STOP mode and "H8001" for RUN mode. See 4.3 for more details.
10	Get/Set	Diagnostic interval time	1 ~ 65 secs	5 secs	The interval when RTU-DNET executes diagnosis.
11	Get/Set	Special module offline treatment	0 ~ 2	1	How RTU-DNET will react when the special module connected to it is offline. 0: Ignored 1: Alarm 2: Stop DeviceNet IO
12	Get/Set	Special module error treatment	0 ~ 2	1	How RTU-DNET will react when it detects errors. 0: Ignored 1: Alarm 2: Stop DeviceNet IO
13	Get/Set	RTU-DNET configuration validation	N/A	0	Validating the configuration of RTU-DNET when set to "11".
14	Get/Set	Reset RTU-DNET	N/A	0	Resetting RTU-DNET when set to "10". After it, the parameter will change to "0" automatically.

■ Class 0x9B – Extension module setup parameter object

Class attribute

Attribute ID	Access rule	Name	Data type
1	Get	Revision	UINT

Instance 1 ~ 8 (parameters for the 1st ~ 8th special modules)

Attribute ID	Access rule	Name	Range	Default	Explanation		
1	Get	Model name	N/A	N/A	Model code for the special module		
2	Get	Length of input data	N/A	N/A	The sum of the input data length of special modules connected. Unit: word		
3	Get	Length of output data	N/A	N/A	The sum of the output data length of special modules connected. Unit: word		
4	Get	Status	0 ~ 63	N/A	b0	0	Special module online
						1	Special module offline
					b1	0	Special module normal
						1	Special module in error
b2	0	Special module and configuration consistent					

Attribute ID	Access rule	Name	Range	Default	Explanation	
					1	Special module and configuration inconsistent
					b3	0 Configuration data valid
						1 Configuration data invalid
					b4	0 Special module identifiable
						1 Special module unidentifiable
					b5~b15	Reserved
5	Get/Set	Work mode	0 ~ 1	0	Work mode of special module 0: auto 1: custom	
6	Get/Set	Number of input data	0 ~ 8	N/A	Number of input data of special modules connected	
7	Get/Set	Number of output data	0 ~ 8	N/A	Number of output data of special module connected	
8	Reserved					
9	Get	Error code		N/A	Error code in special module	
10 ~ 19	Reserved					
20	Get/Set	Start CR for module 1 input data	N/A	N/A	Start CR for the input data of special module 1	
21	Get/Set	Input data length for module 1	N/A	N/A	Length of input data of special module 1	
22	Get/Set	Start CR for module 2 input data	N/A	N/A	Start CR for the input data of special module 2	
23	Get/Set	Input data length for module 2	N/A	N/A	Length of input data of special module 2	
24	Get/Set	Start CR for module 3 input data	N/A	N/A	Start CR for the input data of special module 3	
25	Get/Set	Input data length for module 3	N/A	N/A	Length of input data of special module 3	
26	Get/Set	Start CR for module 4 input data	N/A	N/A	Start CR for the input data of special module 4	
27	Get/Set	Input data length for module 4	N/A	N/A	Length of input data of special module 4	
28	Get/Set	Start CR for module 5 input data	N/A	N/A	Start CR for the input data of special module 5	
29	Get/Set	Input data length for module 5	N/A	N/A	Length of input data of special module 5	

Attribute ID	Access rule	Name	Range	Default	Explanation
30	Get/Set	Start CR for module 6 input data	N/A	N/A	Start CR for the input data of special module 6
31	Get/Set	Input data length for module 6	N/A	N/A	Length of input data of special module 6
32	Get/Set	Start CR for module 7 input data	N/A	N/A	Start CR for the input data of special module 7
33	Get/Set	Input data length for module 7	N/A	N/A	Length of input data of special module 7
34	Get/Set	Start CR for module 8 input data	N/A	N/A	Start CR for the input data of special module 8
35	Get/Set	Input data length for module 8	N/A	N/A	Length of input data of special module 8
36 ~ 49	Reserved				
50	Get/Set	Start CR for module 1 output data	N/A	N/A	Start CR for the output data of special module 1
51	Get/Set	Output data length for module 1	N/A	N/A	Length of output data of special module 1
52	Get/Set	Start CR for module 2 output data	N/A	N/A	Start CR for the output data of special module 2
53	Get/Set	Output data length for module 2	N/A	N/A	Length of output data of special module 2
54	Get/Set	Start CR for module 3 output data	N/A	N/A	Start CR for the output data of special module 3
55	Get/Set	Output data length for module 3	N/A	N/A	Length of output data of special module 3
56	Get/Set	Start CR for module 4 output data	N/A	N/A	Start CR for the output data of special module 4
57	Get/Set	Output data length for module 4	N/A	N/A	Length of output data of special module 4
58	Get/Set	Start CR for module 5 output data	N/A	N/A	Start CR for the output data of special module 5
59	Get/Set	Output data length for module 5	N/A	N/A	Length of output data of special module 5
60	Get/Set	Start CR for module 6 output data	N/A	N/A	Start CR for the output data of special module 6

Attribute ID	Access rule	Name	Range	Default	Explanation
61	Get/Set	Output data length for module 6	N/A	N/A	Length of output data of special module 6
62	Get/Set	Start CR for module 7 output data	N/A	N/A	Start CR for the output data of special module 7
63	Get/Set	Output data length for module 7	N/A	N/A	Length of output data of special module 7
64	Get/Set	Start CR for module 8 output data	N/A	N/A	Start CR for the output data of special module 8
65	Get/Set	Output data length for module 8	N/A	N/A	Length of output data of special module 8

■ Class 0x9C – Extension module parameter object

Class attribute

Attribute ID	Access rule	Name	Data type
1	Get	Revision	UINT
2	Get	MaxInstance	UINT

Instance 1 ~ 8 (CR for the 1st ~ 8th special module)

Attribute ID	Access rule	Name	Data type
1	Get	Content in CR#0	UINT
2	Get/Set	Content in CR#1	UINT
3	Get/Set	Content in CR#2	UINT
...	UINT
9	Get/Set	Content in CR#8	UINT
10	Get/Set	Content in CR#9	UINT
...	UINT

Note:

- When you modify the content in CR of the special module through DeviceNet, please read out the content again (Get_Attribute_Single) after the modification and confirm that it has been modified successfully.
- The content in some CRs of the special module cannot be modified. Therefore, please pay attention to these parameters when you are modifying them.

4.3 DeviceNet I/O Mapping Data

1. Control word and status word in RTU-DNET

■ Control word

bit	Status value	Explanation
0	0	Setting RTU-DNET to STOP mode
	1	Setting RTU-DNET to RUN mode
1	0/1	Reserved

bit	Status value	Explanation
2	0/1	Reserved
3	0/1	Reserved
4	0/1	Reserved
5	0/1	Reserved
6	0/1	Reserved
7	0/1	Reserved
8	0/1	Reserved
9	0/1	Reserved
10	0/1	Reserved
11	0/1	Reserved
12	0/1	Reserved
13	0/1	Reserved
14	0/1	Reserved
15	0	Disabling control word
	1	Enabling control word

■ Status word

bit	Status value	Explanation
0	0	RTU-DNET detects DI/DO extension unit.
	1	RTU-DNET does not detect DI/DO extension unit.
1	0	The configurations of RTU-DNET and the extension unit connected to it are consistent.
	1	The configurations of RTU-DNET and the extension unit connected to it are inconsistent.
2	0	No error occurs in the special module.
	1	Error occurs in the special module.
3	0	The special module operates normally.
	1	The special module is detected offline.
4	0	The configuration data are valid.
	1	The configuration data are invalid.
5	0	RTU-DNET operates normally.
	1	The power of RTU-DNET is in low voltage.
6	0	RTU-DNET operates normally.
	1	RTU-DNET detects unidentifiable special module.
7	0	RTU-DNET operates normally.
	1	More than 8 special modules connected to RTU-DNET, or the number of digital I/O points exceeds 128.
8	0/1	Reserved
9	0/1	Reserved
10	0/1	Reserved
11	0/1	Reserved
12	0/1	Reserved
13	0/1	Reserved

bit	Status value	Explanation
14	0/1	Reserved
15	0/1	Reserved

2. I/O data mapping

- If the I/O data do not include control word and status word of RTU-DNET, the I/O data mapping of DeviceNet master and RTU-DNET will be:

- DeviceNet master → RTU-DNET

Master (byte)	RTU-DNET	
0	Special module	Low byte of the 1 st special module output channel 1
1		High byte of the 1 st special module output channel 1
2		Low byte of the 1 st special module output channel 2
3		High byte of the 1 st special module output channel 2
...		...
N	Slim DI/DO	Y0 ~ Y7 on the 1 st Slim DI/DO
N+1		Y0 ~ Y7 of the 2 nd Slim DI/DO
...		...

- RTU-DNET → DeviceNet master

Master (byte)	RTU-DNET	
0	Special module	Low byte of the 1 st special module input channel 1
1		High byte of the 1 st special module input channel 1
2		Low byte of the 1 st special module input channel 2
3		High byte of the 1 st special module input channel 2
...		...
N	Slim DI/DO	X0 ~ X7 on the 1 st Slim DI/DO
N+1		X0 ~ X7 on the 2 nd Slim DI/DO
...		...

- If the I/O data include control word and status word of RTU-DNET, the I/O data mapping of DeviceNet master and RTU-DNET will be:

- DeviceNet master → RTU-DNET

Master (byte)	RTU-DNET	
0	RTU-DNET	Low byte of control word of RTU-DNET
1		High byte of control word of RTU-DNET
2	Special module	Low byte of the 1 st special module output channel 1
3		High byte of the 1 st special module output channel 1
4		Low byte of the 1 st special module output channel 2
5		High byte of the 1 st special module output channel 2
...		...
N	Slim DI/DO	Y0 ~ Y7 of the 1 st Slim DI/DO
N+1		Y0 ~ Y7 of the 2 nd Slim DI/DO

Master (byte)	RTU-DNET	
...		...

- RTU-DNET → DeviceNet master

Master (byte)	RTU-DNET	
0	RTU-DNET	Low byte of status word of RTU-DNET
1		High byte of status word of RTU-DNET
2	Special module	Low byte of the 1 st special module output channel 1
3		High byte of the 1 st special module output channel 1
4		Low byte of the 1 st special module output channel 2
5		High byte of the 1 st special module output channel 2
...		...
N	Slim DI/DO	X0 ~ X7 of the 1 st Slim DI/DO
N+1		X0 ~ X7 of the 2 nd Slim DI/DO
...		...

Note:

- If you choose to make the control word and status word of RTU-DNET to be I/O data, the first word in the I/O data area will automatically be distributed to control word and status word.
- In the alignment of RTU-DNET and the extension modules connected to it, the data of special modules appear prior to the data of Slim DI/DO extension units.

4.4 Example

1. How to read the I/O data in the extension module connected to RTU-DNET.

Assume the extension modules connected to RTU-DNET are:

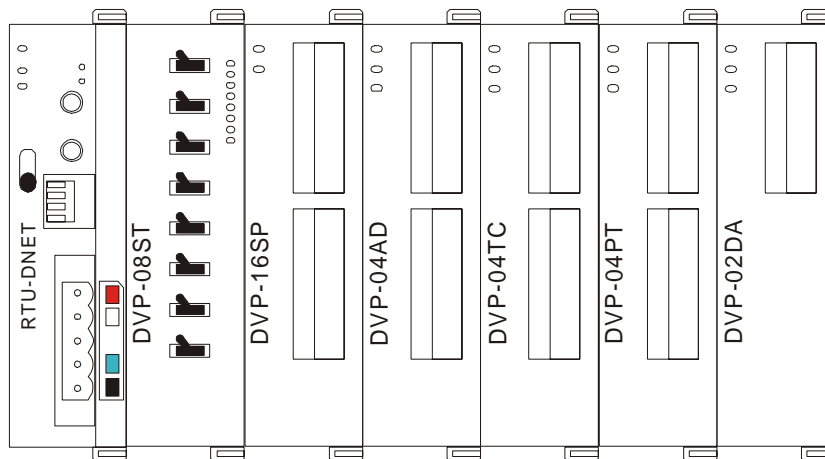

If the I/O data do not include control word and status word of RTU-DNET, the information of the extension module connected to RTU-DNET are as follows:

Item	Content	Software screen
DIDO Input Points (X)	16 bits	
DIDO Output Points (Y)	8 bits	
AIAO Module Number	4	
Input IO Data Length	26 bytes	
Output IO Data Length	5 bytes	

If the I/O data include control word and status word of RTU-DNET, the information of the extension module connected to RTU-DNET are as follows:

Item	Content	Software screen
DIDO Input Points (X)	16 bits	
DIDO Output Points (Y)	8 bits	
AIAO Module Number	4	
Input IO Data Length	28 bytes	
Output IO Data Length	7 bytes	

2. How to change the I/O mapping relation between RTU-DNET and special module

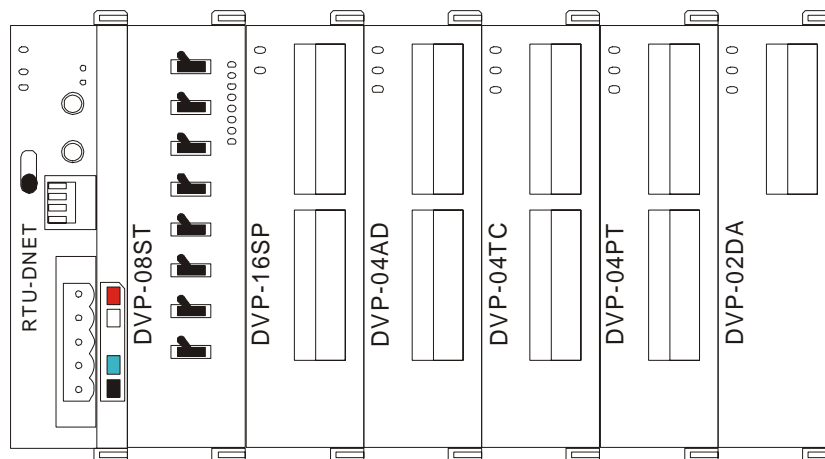

As the figure above, if you need to read the average Celsius degree temperature at CH1 ~ CH4 on DVP-04PT, follow the steps below:

- (1) Scan DeviceNet by using DeviceNetBuilder software. After the scan is completed, the nodes on DeviceNet will be displayed on the screen.

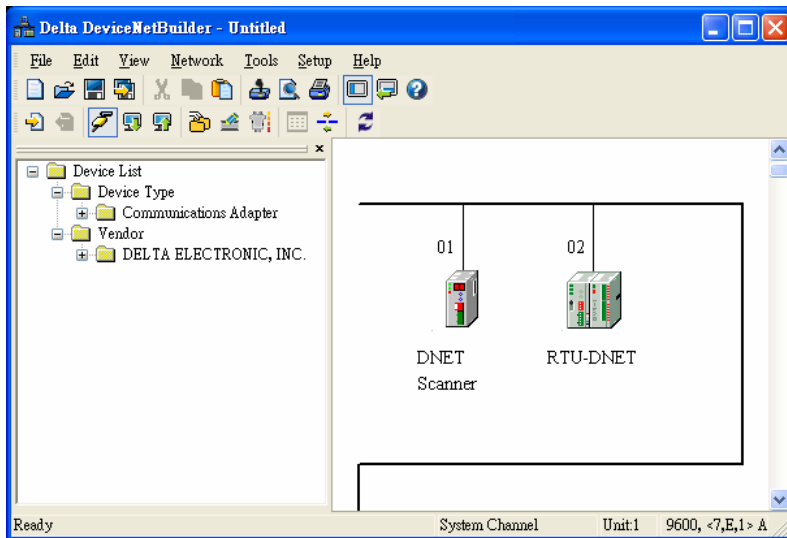

(2) Double click on RTU-DNET icon, and the “Node Configuration...” dialog box will appear.

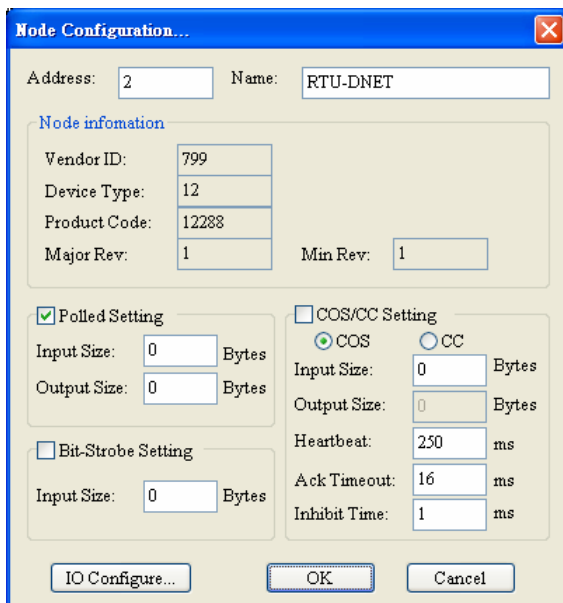

(3) Click on “IO Configure...” button in “Node Cnfiguration...” dialog box, and you will then see “RTU Configuration” page.

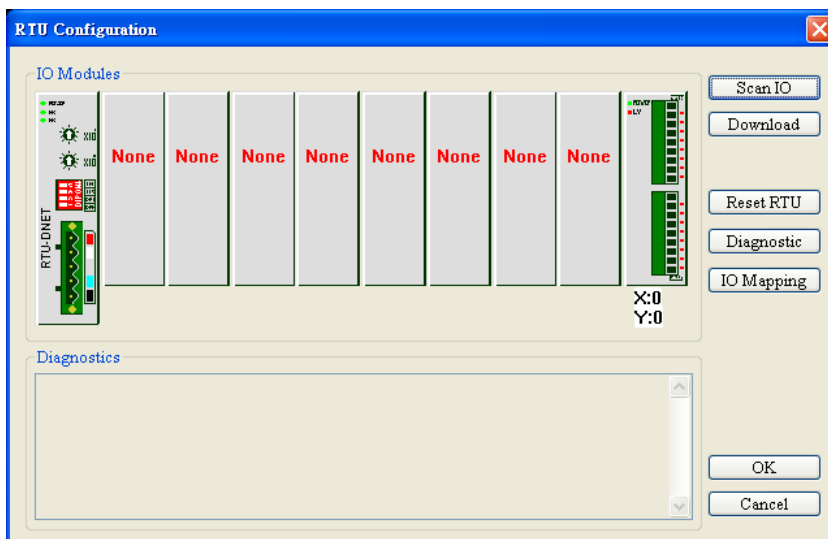

(4) Click on “Scan IO”, and the “Warning” dialog box will appear.

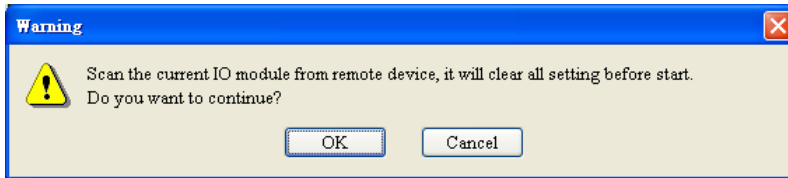

(5) Click on "OK". DeviceNetBuilder will then display the special module connected and the number of digital I/O points on the "RTU Configuration" page.

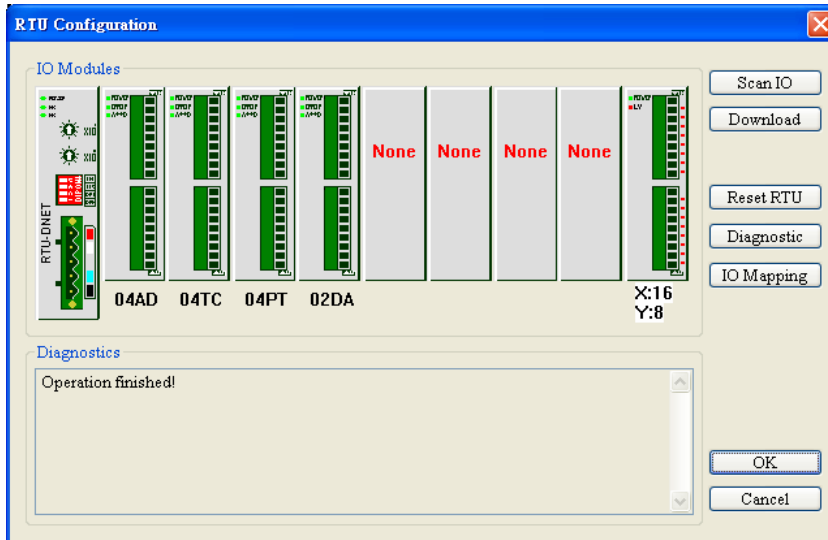

(6) Double click on "04TC" icon, and you will then see the "AIAO Module Configuration" dialog box, as below. The content in Input Data >> Link 1 column is "CR14-Present temperature of CH1(C)".

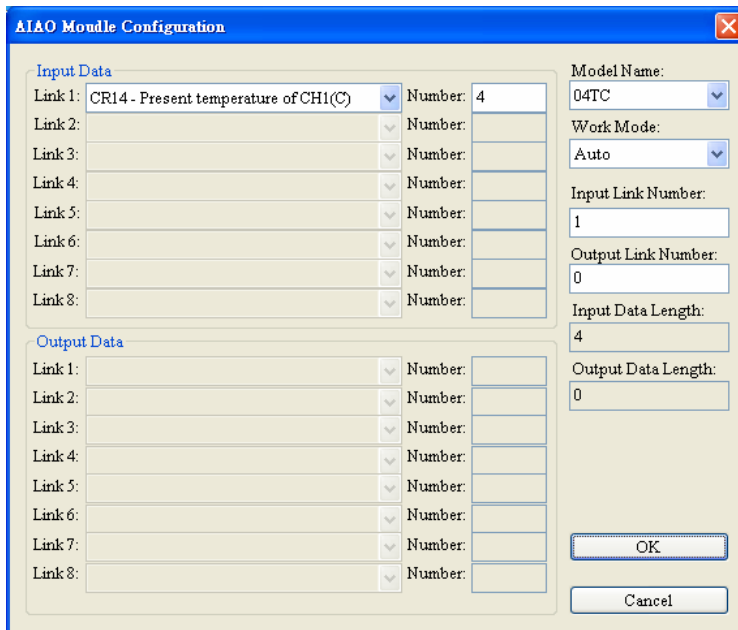

(7) Set the Work Mode to "Custom" and Input Data >> Link 1 to "CR6-CH1 average degree(C)".

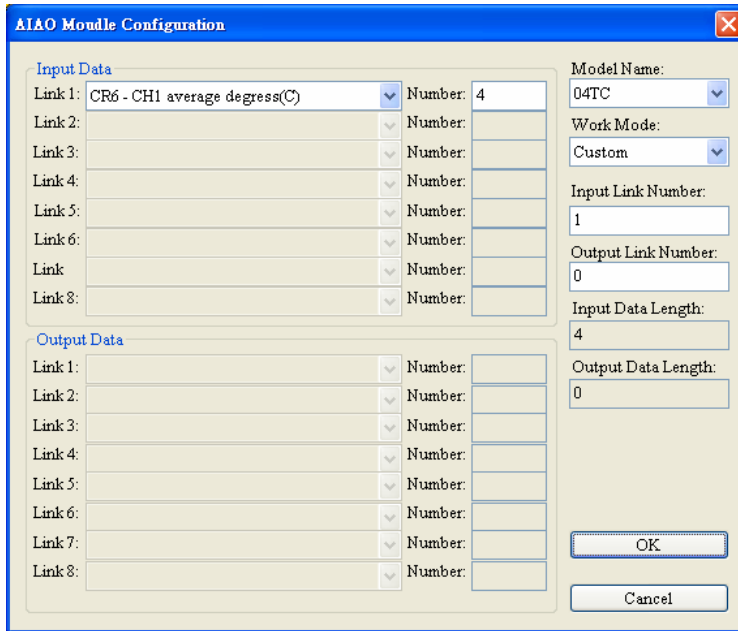

(8) Click on “OK” in “AIAO Module Configuration” page and return to “RTU Configuration” page.

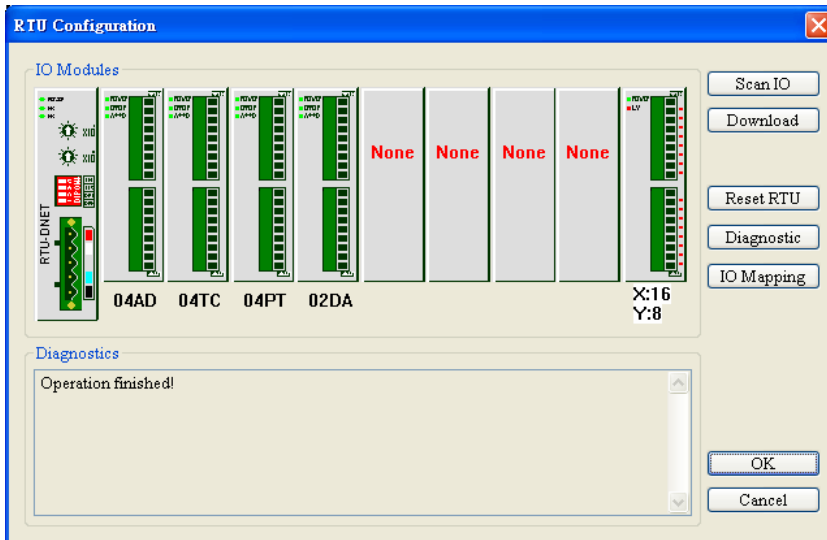

(9) Click on “Download” to download the configuration to RTU-DNET.

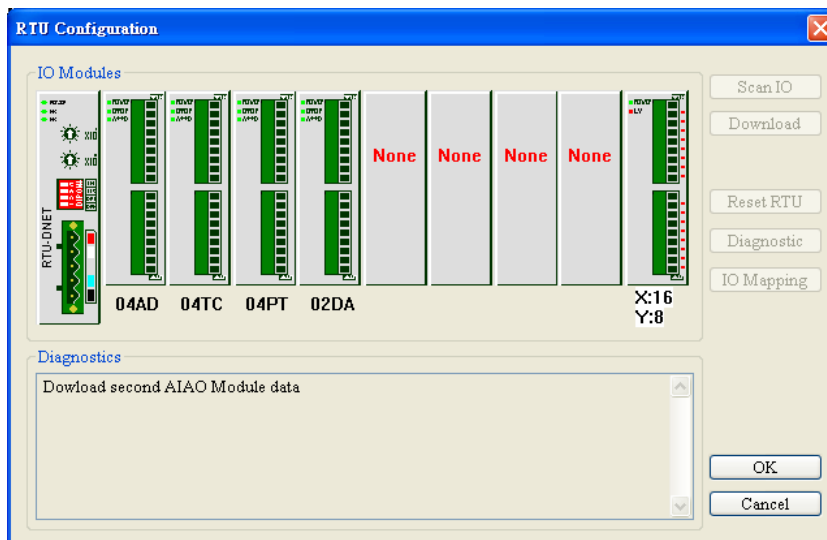

(10) After the download is completed, click on “OK”.

5 How to Construct a DeviceNet Network Using RTU-DNET

In this section, we will explain how to configure RTU-DNET and the I/O mapping relation between RTU-DNET and DVP-DNET-SL by an application example.

5.1 How to Construct DeviceNet by RTU-DNET

1. The DeviceNet network

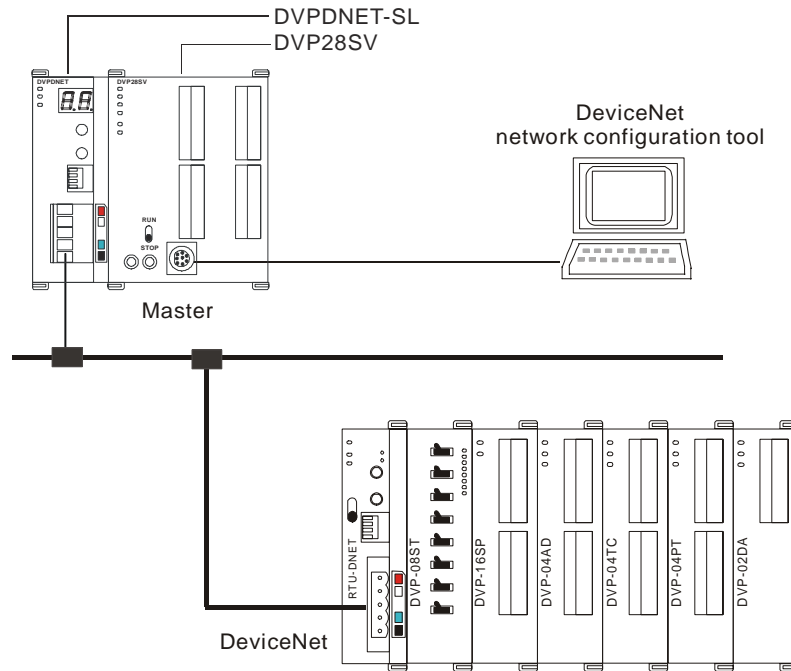

2. Set up DVP-DNET-SL and RTU-DNET according to the table below.

Module	Node address	Baud rate
DVP-DNET-SL	1	500 kbps
RTU-DNET	2	500 kbps

3. Please check if all Slim DI/DO extension units, special modules and RTU-DNET are working normally, if the wiring of the entire network is correct, and if the power supply in DeviceNet is normal.

5.2 How to Configure Network by DeviceNet Network Configuration Tool

1. Configuration of RTU-DNET

(1) Open DeviceNetBuilder software, as below:

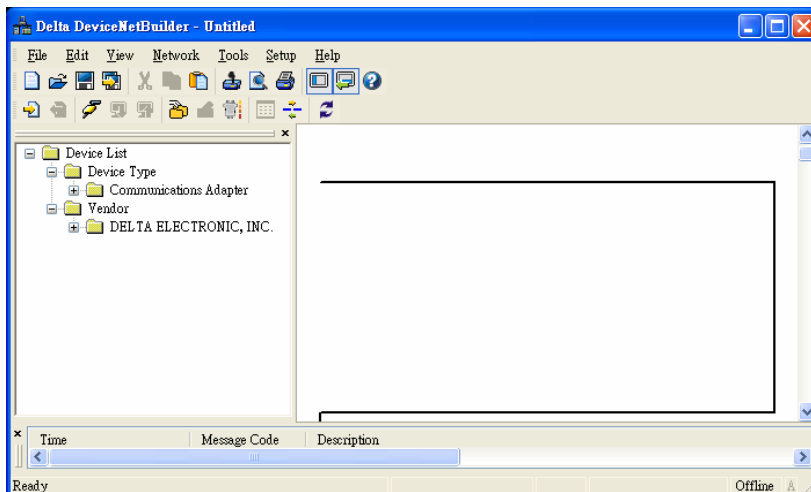

- (2) Select “Setup” => “Communication Setting” => “System Channel”, and the “Serial Port Setting” dialog box will appear.

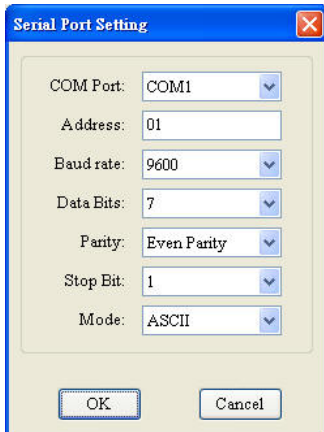

- (3) Set up the communication parameters in the PC and DVP-SV, e.g. the communication port, address, baud rate and communication format.

Item	Function	Default
COM Port	COM port on the PC to be used to communicate with DVP-SV	COM1
Address	Communication address of DVP-SV	01
Baud rate	Communication speed between the PC and DVP-SV	9,600 (bps)
Data Bits	Communication protocol between the PC and DVP-SV	7
Parity		Even Parity
Stop Bit		1
Mode	Communication mode between the PC and DVP-SV	ASCII

- (4) Click on “OK” and return to the main page.

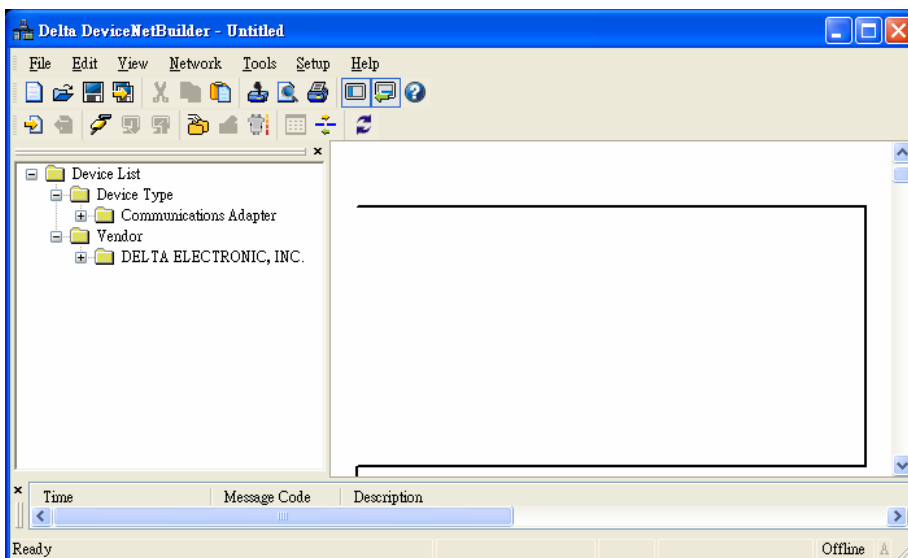

- (5) Select “Network” => “Online”, and the “Select Communication Channel” dialog box will appear.

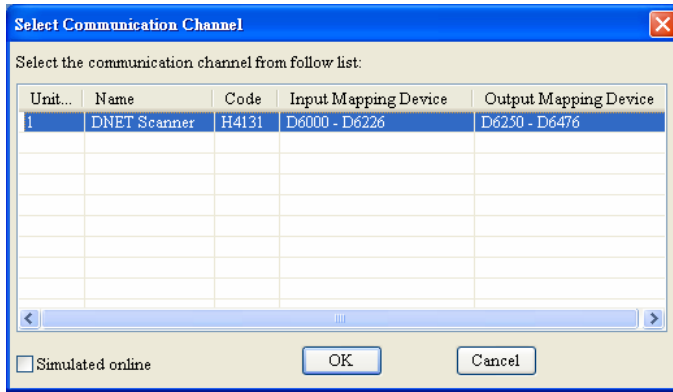

(6) Click on “OK”, and DeviceNetBuilder will start to scan the entire network.

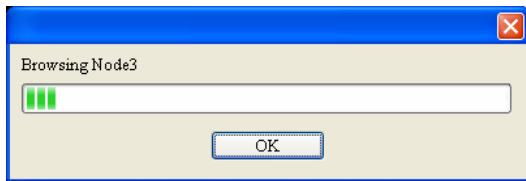

(7) If the bar on the dialog box does not progress, it means the connection between the PC and DVP-SV is abnormal, or there are other programs also using the COM port on the PC. After the scan is completed, the dialog box will tell you that the scan is completed, and the icons and device names of all the nodes scanned on the network will be shown on the screen. See the figure below, in which the node address of DVPDNET-SL is 01.

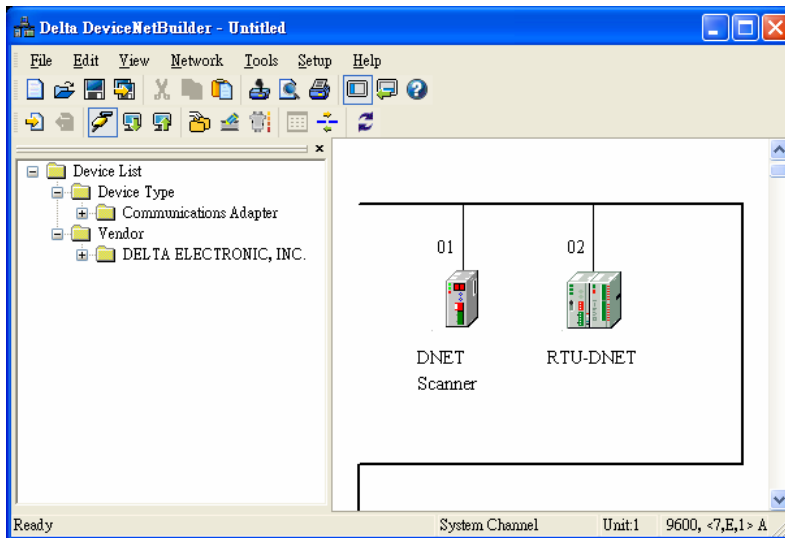

(8) Double click on RTU-DNET (node 02), and the “Node Configuration...” dialog box will appear.

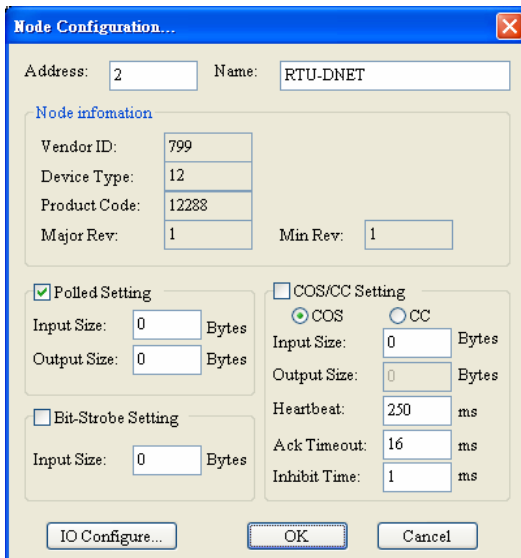

- (9) Click on “IO Configure...” button in “Node Configuration” dialog box, and you will then see “RTU Configuration” page.

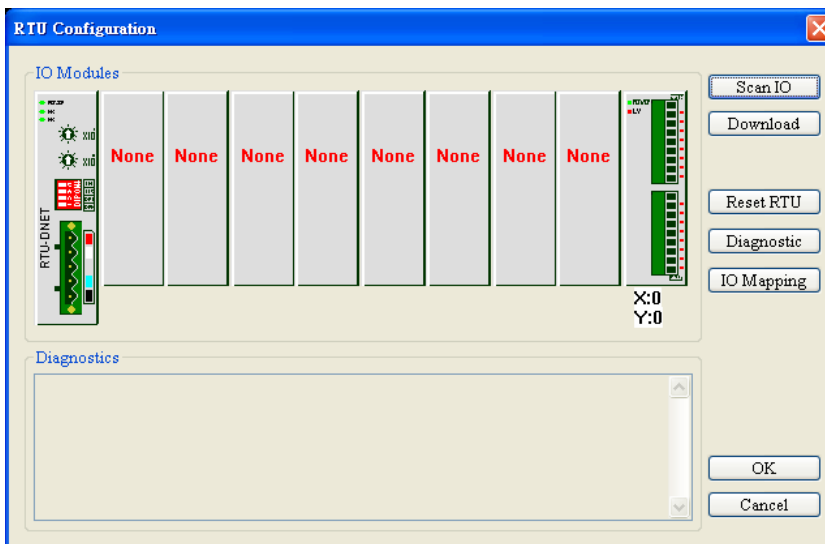

- (10) Click on “Scan IO”, and the “Warning” dialog box will appear.

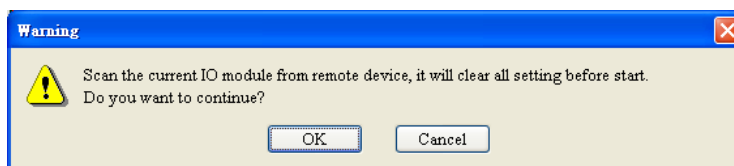

- (11) Click on “OK”. DeviceNetBuilder will then detect the special module connected to RTU-DNET and the number of points in the Slim DI/DO extension unit and display the information on “RTU Configuration” page.

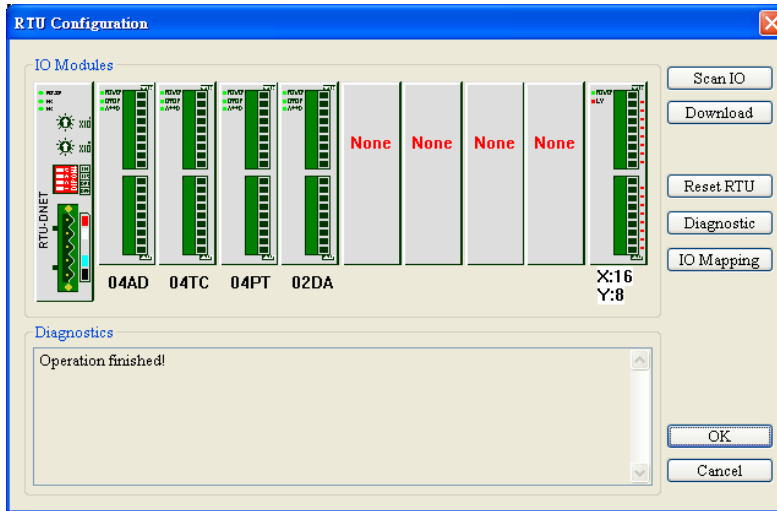

(12) Double click on RTU-DNET icon, and you will then see “RTU Setup” dialog box.

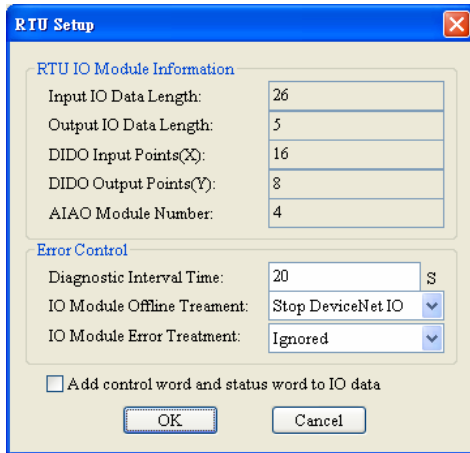

(13) Set up the parameters in RTU-DNET and confirm its I/O information.

Item	Function	Default
Input IO Data Length	The sum of the length of the status word of RTU-DNET and the input data of the special module connected to it. The status word of RTU-DNET occupies 2 bytes. One input channel of the special module occupies 2 bytes. 8 points of the digital input are counted as 1 byte.	N/A
Output IO Data Length	The sum of the length of the control word of RTU-DNET and the output data of the special module connected to it. The control word of RTU-DNET occupies 2 bytes. One output channel of the special module occupies 2 bytes. 8 points of the digital output are counted as 1 byte.	N/A
DIDO Input Points (X)	The digital input points shall be 8's multiple. The number will be regarded as 8 when it is less than 8 and regarded as 16 when it is bigger than 8 but less than 16.	N/A
DIDO Output Points (Y)	The digital output points shall be 8's multiple. The number will be regarded as 8 when it is less than 8 and regarded as 16 when it is bigger than 8 but less than 16.	N/A
AIAO Module Number	The number of special modules connected to RTU-DNET. Range: 0 ~ 8	N/A
Diagnostic Interval Time	The interval when RTU-DNET executes diagnosis. Range: 1~ 65 secs	5 (sec)
IO Module Offline Treatment	How RTU-DNET will react when the special module connected to it is offline. You can choose “Ignored”, “Alarm” or “stop DeviceNet IO”.	Alarm

Item	Function	Default
IO Module Error Treatment	How RTU-DNET will react when it detects errors. You can choose "Ignored", "Alarm" or "Stop DeviceNet IO".	Alarm
Add control word and status word to IO data	For you to decide whether to add control word and status word to I/O data. When you choose not to do it, the I/O data in RTU-DNET and DeviceNet master will not include control word and status word. If you choose to add them in, the I/O data in RTU-DNET and DeviceNet master will include control word and status word.	Not to add

(14) Confirm all the configurations are correct and click on "Download" to download the configuration to RTU-DNET. After the download is completed, click on "OK".

2. Configuration of DVPDNET-SL

(1) Double click on DNET Scanner (node 01), and the "Scan Module Configuration..." dialog box will appear. You can find the currently available node, RTU-DNET, in the list on the left side. On the right side, there is an empty "Scan List".

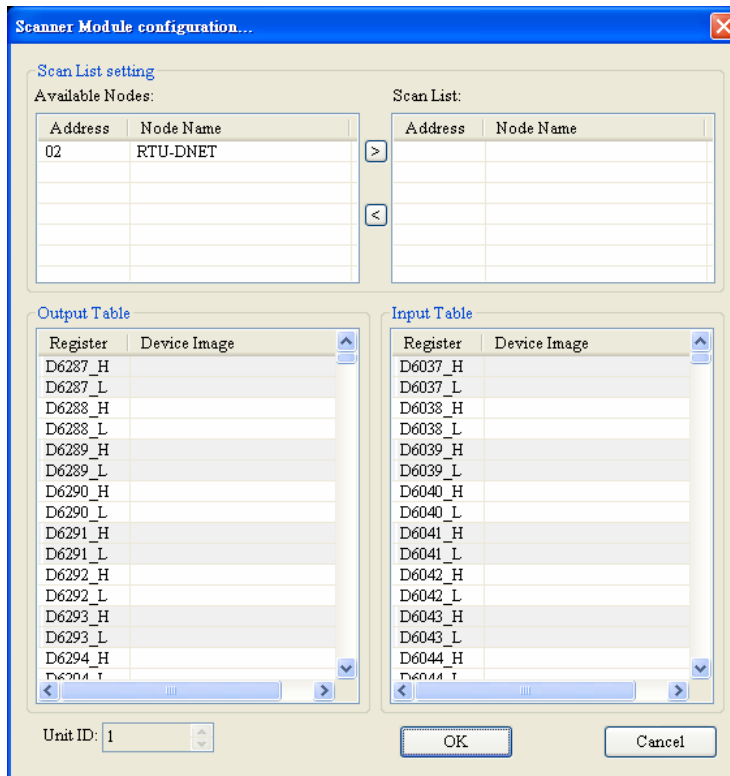

(2) Move the slave devices on DeviceNet in the "Available Nodes" list on the left side to the "Scan List" on the right side. Select a node and click on . Follow the steps to move all the nodes to the scan list.

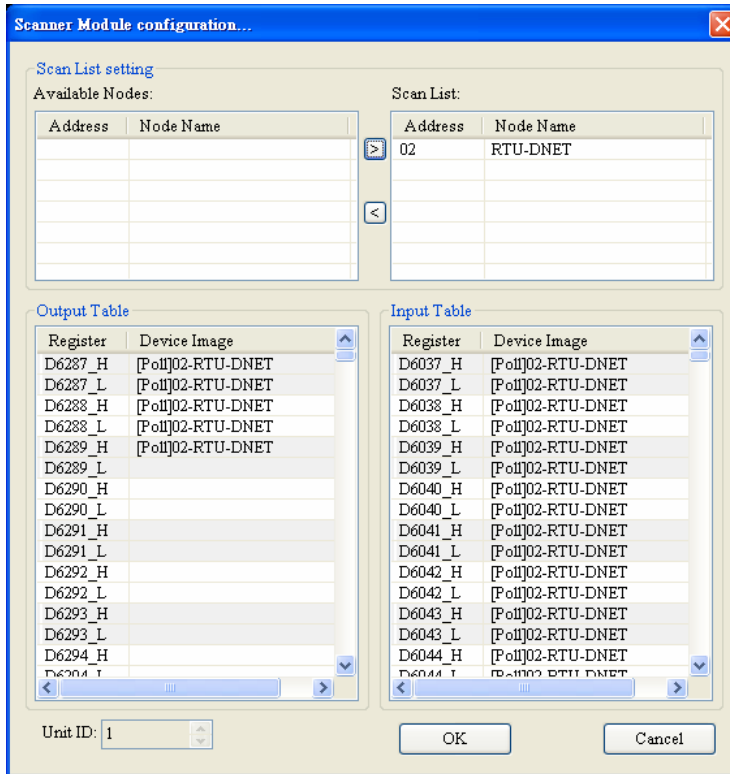

- (3) Confirm all the settings and click on “OK”. Next, download the configuration to DVPDNET-SL. If DVP-SV is in RUN mode while you are downloading the configuration, a "Warning" dialog box will appear.

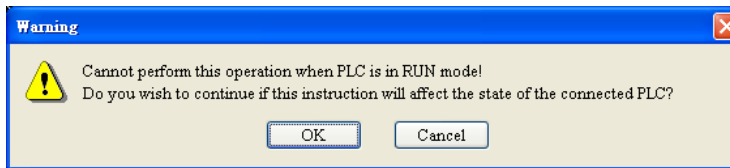

- (4) Click on “OK” to continue the download. Make sure DVP-SV is in RUN mode. Now, you can see the MS LED and NS LED on RTU-DNET become green.

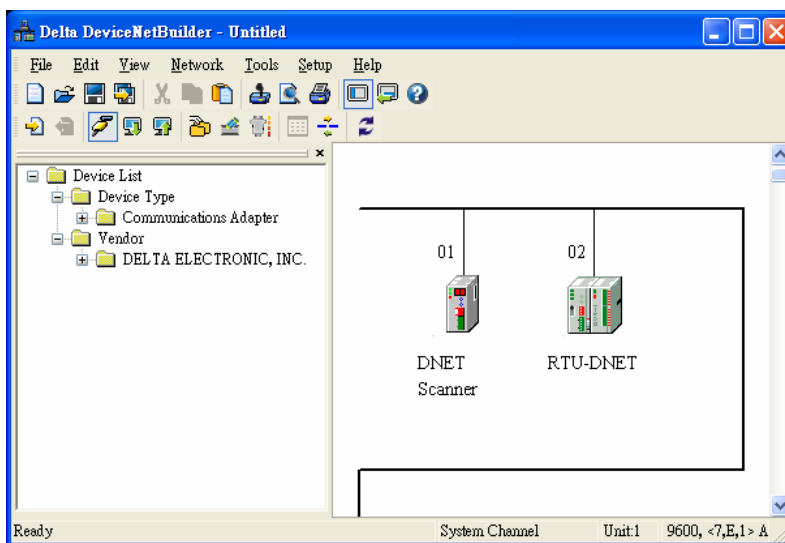

3. Follow the steps given above to configure DeviceNet network. If the I/O data do not include control word and status word of RTU-DNET, the I/O data mapping of DVPDNET-SL and RTU-DNET will be:

(1) DVPDNET-SL → RTU-DNET

Register in DVPDNET-SL		Devices in extension module	
D6287H	⇨	Special module	High byte of CH1 on DVP-02DA
D6287L			Low byte of CH1 on DVP-02DA
D6288H			High byte of CH2 on DVP-02DA
D6288L			Low byte of CH2 on DVP-02DA
D6289H		Slim DI/DO	Y0 ~ Y7 on DVP-16SP

(2) RTU-DNET → DVPDNET-SL

Register in DVPDNET-SL		Devices in extension module		
D6037H	⇨	Special module	High byte of CH1 on DVP-04AD	
D6037L			Low byte of CH1 on DVP-04AD	
D6038H			High byte of CH2 on DVP-04AD	
D6038L			Low byte of CH2 on DVP-04AD	
D6039H			High byte of CH3 on DVP-04AD	
D6039L			Low byte of CH3 on DVP-04AD	
D6040H			High byte of CH4 on DVP-04AD	
D6040L			Low byte of CH4 on DVP-04AD	
D6041H			High byte of CH1 on DVP-04TC	
D6041L			Low byte of CH1 on DVP-04TC	
D6042H			High byte of CH2 on DVP-04TC	
D6042L			Low byte of CH2 on DVP-04TC	
D6043H			High byte of CH3 on DVP-04TC	
D6043L			Low byte of CH3 on DVP-04TC	
D6044H			High byte of CH4 on DVP-04TC	
D6044L			Low byte of CH4 on DVP-04TC	
D6045H			High byte of CH1 on DVP-04PT	
D6045L			Low byte of CH1 on DVP-04PT	
D6046H			High byte of CH2 on DVP-04PT	
D6046L			Low byte of CH2 on DVP-04PT	
D6047H			High byte of CH3 on DVP-04PT	
D6047L			Low byte of CH3 on DVP-04PT	
D6048H			High byte of CH4 on DVP-04PT	
D6048L			Low byte of CH4 on DVP-04PT	
D6049H			Slim DI/DO	X0 ~ X7 on DVP-08ST
D6049L			Slim DI/DO	X0 ~ X7 on DVP-16SP

4. If the I/O data include control word and status word of RTU-DNET, the I/O data mapping of DVPDNET-SL and RTU-DNET will be:

(1) DVPDNET-SL → RTU-DNET

Register in DVP-DNET-SL		Devices in extension module	
D6287H	⇒	RTU-DNET control word	High byte of control word in RTU-DNET
D6287L			Low byte of control word in RTU-DNET
D6288H		Special module	High byte of CH1 on DVP-02DA
D6288L			Low byte of CH1 on DVP-02DA
D6289H			High byte of CH2 on DVP-02DA
D6289L			Low byte of CH2 on DVP-02DA
D6290H		Slim DI/DO	Y0 ~ Y7 on DVP-16SP

(2) RTU-DNET → DVP-DNET-SL

Register in DVP-DNET-SL		Devices in extension module	
D6037H	⇐	RTU-DNET status word	High byte of status word in RTU-DNET
D6037L			Low byte of status word in RTU-DNET
D6038H		Special module	High byte of CH1 on DVP-04AD
D6038L			Low byte of CH1 on DVP-04AD
D6039H			High byte of CH2 on DVP-04AD
D6039L			Low byte of CH2 on DVP-04AD
D6040H			High byte of CH3 on DVP-04AD
D6040L			Low byte of CH3 on DVP-04AD
D6041H			High byte of CH4 on DVP-04AD
D6041L			Low byte of CH4 on DVP-04AD
D6042H			High byte of CH1 on DVP-04TC
D6042L			Low byte of CH1 on DVP-04TC
D6043H			High byte of CH2 on DVP-04TC
D6043L			Low byte of CH2 on DVP-04TC
D6044H			High byte of CH3 on DVP-04TC
D6044L			Low byte of CH3 on DVP-04TC
D6045H			High byte of CH4 on DVP-04TC
D6045L			Low byte of CH4 on DVP-04TC
D6046H			High byte of CH1 on DVP-04PT
D6046L			Low byte of CH1 on DVP-04PT
D6047H			High byte of CH2 on DVP-04PT
D6047L			Low byte of CH2 on DVP-04PT
D6048H		High byte of CH3 on DVP-04PT	
D6048L		Low byte of CH3 on DVP-04PT	
D6049H		High byte of CH4 on DVP-04PT	
D6049L		Low byte of CH4 on DVP-04PT	
D6050H		Slim DI/DO	X0 ~ X7 on DVP-08ST
D6050L			X0 ~ X7 on DVP-16SP

6 LED Indicator & Trouble-shooting

There are five LED indicators on RTU-DNET. POWER LED displays if the power of RTU-DNET is working normally. RUN LED displays the working status of RTU-DNET. ALARM LED shows if RTU-DNET is operating normally. NS LED and MS LED display the communication connection status of RTU-DNET.

6.1 POWER LED

LED status	Indication	How to correct
Off	Power is abnormal.	Make sure RTU-DNET is powered.
Green light on	Power is normal.	--

6.2 NS LED

LED status	Indication	How to correct
Off	No power or duplicate ID check has not completed.	<ol style="list-style-type: none"> 1. Make sure RTU-DNET is powered. 2. Make sure the nodes on the bus are communicating normally. 3. Make sure at least 1 node or more are communicating on the network through RTU-DNET. 4. Check if the baud rate of RTU-DNET is the same as that of the master.
Green light blinking	On-line but not connected to DeviceNet	--
Green light on	On-line and connected to DeviceNet normally	--
Red light blinking	On-line but I/O connection timed-out	--
Red light on	Network error, cannot check duplicate ID, no network power or bus-off	<ol style="list-style-type: none"> 1. Make sure all the devices have their unique node address. 2. Check the network for correcting media installation and baud rate. 3. Check if the node address of RTU-DNET is valid. 4. Check if the network power is normal.

6.3 MS LED

LED status	Indication	How to correct
Off	No power or off-line	Make sure RTU-DNET is powered.
Green light blinking	Waiting for I/O data, no I/O data or PLC is in STOP mode.	Switch the PLC to RUN status and start I/O data exchange.
Green light on	I/O data are normal.	--
Red light blinking	No network power; configuration error	<ol style="list-style-type: none"> 1. Check if the network power is normal. 2. Reset the parameters in RTU-DNET.
Red light on	Hardware error	Send your RTU-DNET back to the factory for repair.

6.4 ALARM LED

LED status	Indication	How to correct
Off	Normal	--
Red light blinking	RTU-DNET detects low	1. Make sure RTU-DNET is powered.

LED status	Indication	How to correct
	voltage	2. Acquire diagnostic information through DeviceNetBuilder.
Red light on	Fatal error; errors in configuration data	Acquire diagnostic information through DeviceNetBuilder.

6.5 RUN LED

LED status	Indication	How to correct
Off	RTU-DNET in STOP mode	--
Green light on	RTU-DNET in RUN mode	--

Appendix A: DeviceNet Objects RTU-DNET Supports

■ DeviceNet objects

Class	Object
0x01	Identity object
0x02	Message router object
0x03	DeviceNet object
0x05	Connection object
0x9A	RTU-DNET setup parameter object
0x9B	Extension module setup parameter object
0x9C	Extension module parameter object

■ Class 0x01 – Identity object

Class attribute

Attribute ID	Access rule	Name	Data type
1	Get	Revision	UINT
2	Get	MaxInstance	UINT
3	Get	NumberOfInstances	UINT
6	Get	MaxIdClass	UINT
7	Get	MaxIdInstance	UINT

Instance

Attribute ID	Access rule	Name	Data type
1	Get	VendorId	UINT
2	Get	DeviceType	UINT
3	Get	ProductCode	UINT
4	Get	Revision MaxRev MinRev	USINT USINT
5	Get	Status	WORD
6	Get	Sn	UDINT
7	Get	ProdName StrLen ASCIIStr	USINT STRING

Common services

Service code	Implemented for		Service name
	Class	Instance	
0x05	No	Yes	Reset
0x0E	Yes	Yes	Get_Attribute_Single
0x10	No	No	Find_Next_Object_Instance

■ Class 0x02 – Message router object

Class attribute

Attribute ID	Access rule	Name	Data type
1	Get	Revision	UINT
6	Get	MaxIdClass	UINT
7	Get	MaxIdInstance	UINT

Instance

Attribute ID	Access rule	Name	Data type
2	Get	NumAvailable	UINT
3	Get	NumActive	UINT

Common services

Service code	Implemented for		Service name
	Class	Instance	
0x0E	Yes	Yes	Get_Attribute_Single

■ Class 0x03 – DeviceNet object

Class attribute

Attribute ID	Access rule	Name	Data type
1	Get	Revision	UINT

Instance attribute

Attribute ID	Access rule	Name	Data type
1	Get	MACID	USINT
2	Get	BaudRate	USINT
3	Get/Set	BusofInterrupt	BOOL
4	Get/Set	BusofCounter	USINT
5	Get	AllocationInfo AllocationChoice MasterNodeAddress	BYTE USINT
6	Get	MACIDSwitchChanged	BOOL
7	Get	BaudRateSwitchChanged	BOOL
8	Get	MACIDSwitchValue	USINT
9	Get	BaudRateSwitchValue	USINT

Common services

Service code	Implemented for		Service name
	Class	Instance	
0x0E	Yes	Yes	Get_Attribute_Single

Service code	Implemented for		Service name
	Class	Instance	
0x10	No	Yes	Set_Attribute_Single
0x4B	No	Yes	Allocate_Master/Slave_Connection_Set
0x4C	No	Yes	Release_Master/Slave_Connection_Set

■ Class 0x05 – Connection object

Class attribute

Attribute ID	Access rule	Name	Data type
1	Get	Revision	UINT

Instance 1: Explicit message connection

Attribute ID	Access rule	Name	Data type
1	Get	State	USINT
2	Get	InstanceType	USINT
3	Get	TransportClassTrigger	USINT
4	Get	ProducedConnectionId	UINT
5	Get	ConsumedConnectionId	UINT
6	Get	InitialCommCharacteristics	BYTE
7	Get	ProducedConnectionSize	UINT
8	Get	ConsumedConnectionSize	UINT
9	Get/Set	ExpectedPackedRate	UINT
12	Get/Set	WatchdogTim-outAction	USINT
13	Get	Produced Connection Path Length	USINT
14	Get	Produced Connection Path	EPATH
15	Get	Consumed Connection Path Length	USINT
16	Get	Consumed Connection Path	EPATH

Instance 2: Polled I/O connection

Attribute ID	Access rule	Name	Data type
1	Get	State	USINT
2	Get	InstanceType	USINT
3	Get	TransportClassTrigger	USINT
4	Get	ProducedConnectionId	UINT
5	Get	ConsumedConnectionId	UINT
6	Get	InitialCommCharacteristics	BYTE
7	Get	ProducedConnectionSize	UINT
8	Get	ConsumedConnectionSize	UINT
9	Get/Set	ExpectedPackedRate	UINT
12	Get/Set	WatchdogTimeoutAction	USINT
13	Get	Produced Connection Path Length	USINT
14	Get	Produced Connection Path	EPATH
15	Get	Consumed Connection Path Length	USINT
16	Get	Consumed Connection Path	EPATH

Common services

Service code	Implemented for		Service name
	Class	Instance	
0x05	No	Yes	Reset
0x0E	Yes	Yes	Get_Attribute_Single
0x10	No	Yes	Set_Attribute_Single

Appendix B: DeviceNet Objects Defined by RTU-DNET

- Class 0x9A – RTU-DNET setup parameter object

Class attribute

Attribute ID	Access rule	Name	Data type
1	Get	Revision	UINT

Instance 1

Attribute ID	Access rule	Name	Range	Default	Explanation
1	Get	Length of input I/O data	N/A	N/A	The sum of the length of the status word of RTU-DNET and the input data of the module connected to it. Unit: byte
2	Get	Length of output I/O data	N/A	N/A	The sum of the length of the control word of RTU-DNET and the output data of the module connected to it. Unit: byte
3	Get	Number of digital input points (X)	0 ~ 128	N/A	The number will be regarded as 8 when it is less than 8 and as 16 when it is bigger than 8 but less than 16. Unit: bit
4	Get	Number of digital output points (Y)	0 ~ 128	N/A	The number will be regarded as 8 when it is less than 8 and as 16 when it is bigger than 8 but less than 16. Unit: bit
5	Get	Number of special modules	0 ~ 8	N/A	The number of special modules connected to RTU-DNET
6	Get	Length of analog input	N/A	N/A	The length of input data of the special module connected to RTU-DNET. Unit: word
7	Get	Length of analog output	N/A	N/A	The length of output data of the special module connected to RTU-DNET. Unit: word
8	Get	Status word	0 ~ 255	N/A	Displaying the status of RTU-DNET. See 4.3 for more details.
9	Get/Set	Control word	N/A	N/A	For setting up the mode of RTU-DNET, e.g. "H8000" for STOP mode and "H8001" for RUN mode. See 4.3 for more details.
10	Get/Set	Diagnostic interval time	1 ~ 65 secs	5 secs	The interval when RTU-DNET executes diagnosis.
11	Get/Set	Special module	0 ~ 2	1	How RTU-DNET will react when the special module connected to it is offline.

Attribute ID	Access rule	Name	Range	Default	Explanation
		offline treatment			0: Ignored 1: Alarm 2: Stop DeviceNet IO
12	Get/Set	Special module error treatment	0 ~ 2	1	How RTU-DNET will react when it detects errors. 0: Ignored 1: Alarm 2: Stop DeviceNet IO
13	Get/Set	RTU-DNET configuration validation	N/A	0	Validating the configuration of RTU-DNET when set to "11".
14	Get/Set	Reset RTU-DNET	N/A	0	Resetting RTU-DNET when set to "10". After it, the parameter will change to "0" automatically.

Common services

Service code	Implemented for		Service name
	Class	Instance	
0x0E	Yes	Yes	Get_Attribute_Single
0x10	No	Yes	Set_Attribute_Single

■ Class 0x9B – Extension module setup parameter object

Class attribute

Attribute ID	Access rule	Name	Data type
1	Get	Revision	UINT

Instance 1 ~ 8 (parameters for the 1st ~ 8th special modules)

Attribute ID	Access rule	Name	Range	Default	Explanation		
1	Get	Model name	N/A	N/A	Model code for the special module		
2	Get	Length of input data	N/A	N/A	The sum of the input data length of special modules connected. Unit: word		
3	Get	Length of output data	N/A	N/A	The sum of the output data length of special modules connected. Unit: word		
4	Get	Status	0 ~ 63	N/A	b0	0	Special module online
						1	Special module offline
					b1	0	Special module normal
						1	Special module in error
					b2	0	Special module and configuration consistent
						1	Special module and configuration inconsistent
					b3	0	Configuration data valid
						1	Configuration data invalid
b4	0	Special module identifiable					

DeviceNet Remote I/O Communication Module RTU-DNET

Attribute ID	Access rule	Name	Range	Default	Explanation	
					1	Special module unidentifiable
					b5 ~ b15	Reserved
5	Get/Set	Work mode	0 ~ 1	0	Work mode of special module 0: auto 1: custom	
6	Get/Set	Number of input data	0 ~ 8	N/A	Number of input data of special modules connected	
7	Get/Set	Number of output data	0 ~ 8	N/A	Number of output data of special modules connected	
8	Reserved					
9	Get	Error code		N/A	Error code in special module	
10~19	Reserved					
20	Get/Set	Start CR for module 1 input data	N/A	N/A	Start CR for the input data of special module 1	
21	Get/Set	Input data length for module 1	N/A	N/A	Length of input data of special module 1	
22	Get/Set	Start CR for module 2 input data	N/A	N/A	Start CR for the input data of special module 2	
23	Get/Set	Input data length for module 2	N/A	N/A	Length of input data of special module 2	
24	Get/Set	Start CR for module 3 input data	N/A	N/A	Start CR for the input data of special module 3	
25	Get/Set	Input data length for module 3	N/A	N/A	Length of input data of special module 3	
26	Get/Set	Start CR for module 4 input data	N/A	N/A	Start CR for the input data of special module 4	
27	Get/Set	Input data length for module 4	N/A	N/A	Length of input data of special module 4	
28	Get/Set	Start CR for module 5 input data	N/A	N/A	Start CR for the input data of special module 5	
29	Get/Set	Input data length for module 5	N/A	N/A	Length of input data of special module 5	
30	Get/Set	Start CR for module 6 input data	N/A	N/A	Start CR for the input data of special module 6	
31	Get/Set	Input data length for module 6	N/A	N/A	Length of input data of special module 6	
32	Get/Set	Start CR for module 7 input data	N/A	N/A	Start CR for the input data of special module 7	
33	Get/Set	Input data length for module 7	N/A	N/A	Length of input data of special module 7	
34	Get/Set	Start CR for module 8 input data	N/A	N/A	Start CR for the input data of special module 8	
35	Get/Set	Input data length for module 8	N/A	N/A	Length of input data of special module 8	
36 ~ 49	Reserved					
50	Get/Set	Start CR for module 1 output data	N/A	N/A	Start CR for the output data of special module 1	
51	Get/Set	Output data length	N/A	N/A	Length of output data of special module 1	

Attribute ID	Access rule	Name	Range	Default	Explanation
		for module 1			
52	Get/Set	Start CR for module 2 output data	N/A	N/A	Start CR for the output data of special module 2
53	Get/Set	Output data length for module 2	N/A	N/A	Length of output data of special module 2
54	Get/Set	Start CR for module 3 output data	N/A	N/A	Start CR for the output data of special module 3
55	Get/Set	Output data length for module 3	N/A	N/A	Length of output data of special module 3
56	Get/Set	Start CR for module 4 output data	N/A	N/A	Start CR for the output data of special module 4
57	Get/Set	Output data length for module 4	N/A	N/A	Length of output data of special module 4
58	Get/Set	Start CR for module 5 output data	N/A	N/A	Start CR for the output data of special module 5
59	Get/Set	Output data length for module 5	N/A	N/A	Length of output data of special module 5
60	Get/Set	Start CR for module 6 output data	N/A	N/A	Start CR for the output data of special module 6
61	Get/Set	Output data length for module 6	N/A	N/A	Length of output data of special module 6
62	Get/Set	Start CR for module 7 output data	N/A	N/A	Start CR for the output data of special module 7
63	Get/Set	Output data length for module 7	N/A	N/A	Length of output data of special module 7
64	Get/Set	Start CR for module 8 output data	N/A	N/A	Start CR for the output data of special module 8
65	Get/Set	Output data length for module 8	N/A	N/A	Length of output data of special module 8

Common services

Service code	Implemented for		Service name
	Class	Instance	
0x0E	Yes	Yes	Get_Attribute_Single
0x10	No	Yes	Set_Attribute_Single

■ Class 0x9C – Extension module parameter object

Class attribute

Attribute ID	Access rule	Name	Data type
1	Get	Revision	UINT
2	Get	MaxInstance	UINT

Instance 1 ~ 8 (CR for the 1st ~ 8th special module)

Attribute ID	Access rule	Name	Data type
1	Get	Content in CR#0	UINT
2	Get/Set	Content in CR#1	UINT
3	Get/Set	Content in CR#2	UINT

Attribute ID	Access rule	Name	Data type
...	UINT
9	Get/Set	Content in CR#8	UINT
10	Get/Set	Content in CR#9	UINT
...	UINT

Common services

Service code	Implemented for		Data type
	Class	Instance	
0x0E	Yes	Yes	Get_Attribute_Single
0x10	No	Yes	Set_Attribute_Single