

DOP Extension Digital I/O Module

Instruction Sheet

- Warning**
- ✓ Please read this instruction carefully before use.
 - ✓ DOP series Extension Digital I/O Module should be used with DOP-AE series HMI product. Ensure to switch off the power before wiring.
 - ✓ Please install this DOP series Extension Digital I/O Module in an enclosure free of airborne dust, humidity, electric shock and vibration. The enclosure should prevent non-maintenance staff from operating the device (e.g. key or specific tools are required for opening the enclosure) in case danger and damage on the device may occur.
 - ✓ DO NOT connect input AC power supply to any of the I/O terminals; otherwise serious damage may occur. Check all the wiring again before switching on the power.
 - ✓ DO NOT touch any internal circuit in 1 minute after the power is switched off. Do NOT touch any terminal when the power is switched on.
 - ✓ Make sure the ground terminal (⊕) is correctly grounded in order to prevent electromagnetic interference.
 - ✓ DO NOT place any heavy objects on the connection port of DOP series Extension Digital I/O Module. Doing so may damage the product.

1 Introduction

1.1 Model Explanation

DOP (1)	-	EXIO (2)	14 (3)	R (4)	AE (5)
(1) Product Name		DOP: Delta Operation Panel			
(2) Series		EXIO: Extension Digital I/O			
(3) Input / Output Point		14: 8 input points / 6 output points 28: 16 input points / 12 output points			
(4) Output Contact Type		R: Relay			
(5) Applicable HMI Series		AE: DOP-AE Series HMI			

1.2 Product Outline

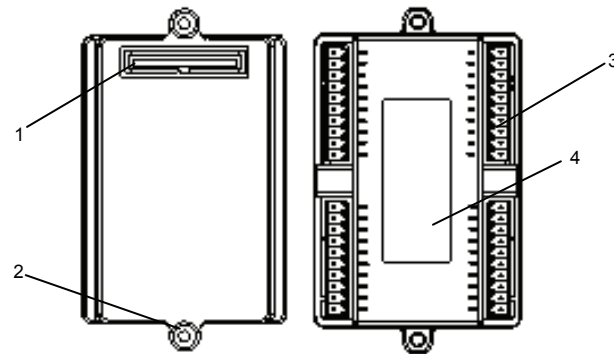

1. Connection Port
2. Direct Mounting Hole
3. Input / Output Terminals
4. Nameplate

1.3 Model Name

Model Name	Power	Input / Output			
		Input Unit		Output Unit	
		Point	Type	Point	Type
DOP-EXIO14RAE	5VDC, supplied by HMI	8	DC Type Sink or Source	6	Relay
DOP-EXIO28RAE		16		12	Relay

2 Function Specifications

Item	Specifications	Remark	
Control Method	Stored program, cyclic scan system	-	
I/O Processing Method	Batch I/O (refresh)	Immediate refresh command available only with I/O of the MPU	
Execution Speed	Basic command (30 us)	Application command (30 ~ hundreds us)	
Program Language	Commands + Ladder Diagram + SFC	Step commands included	
Program Capacity	999 Steps	Built-in EEPROM	
Commands	Basic commands: 32 (including the STL commands)	Application commands: 59	
Step Relay (Latched)	General Step Point	128 Points	
Auxiliary Relay	General	1280 Points	M0 ~ M511, M768 ~ M999, 744 points; M1000 ~ M1279, 280 points ¹
	Latched	256 Points	M512 ~ M767
Timer	Digital	64 Points	T0~T63 (100 ms time base)
		63 Points	T64~T126 (10 ms time base)
		1 Points	T127 (1 ms time base)
Counter	General	112 Points	C0 ~ C111
		Latched	16 Points
	32bit	13 Points	C235, C236, C237, C238, C241, C242, C244, C246, C247, C249, C251, C252, C254 (all of them are latched type)
Data Register	General	408 Points	D0 ~ D407
	Latched	192 Points	D408 ~ D599
Pointer	P	64 Points	P0 ~ P63
Index Register	E / F	2	E, F
Constant	Decimal K	16bit: -32768 ~ +32767	32bit: -2147483648 ~ +2147483647
	Hexadecimal H	16bit: 0000 ~ FFFF	32bit: 00000000 ~ FFFFFFFF
Self Diagnosis / Protection		I/O check, system execution timeout check, invalid command check, program check and password settings	
Monitor / Debug		Program execution time display, bit / word, device settings	

¹: M1000, M1001, M1002, M1003, M1020, M1021, M1022, M1067, M10068, and M1161 are the special auxiliary relays (special M).

3 Electrical Specifications

Item / Model Name	DOP-EXIO14RAE	DOP-EXIO28RAE
Power Supply Voltage	5VDC, 1A (supplied by HMI)	
Power Consumption	0.25W	0.5W
Noise Immunity	RS: Frequency: 80MHz ~ 1GHz, 1.4GHz ~ 2.0GHz, Test level 10V/m CS: Frequency: 0.15MHz ~ 80MHz, Test level 10V (HMI power port & I/O line) ESD: Air discharge ±8KV EFT: ±1.5KV (HMI power port) ±1KV (I/O line) Surge: ±2KV (HMI power port)	
Ambient Temperature / Humidity	Operation: 0°C ~ 50°C (Temperature), 10 ~ 90% (Humidity), Storage: -40°C ~ 85°C (Temperature), 10 ~ 90% (Humidity)	
Vibration / Shock	IEC 61131-2 Compliant 5Hz ≤ f < 9Hz = Continuous: 1.75mm / Occasional: 3.5mm 9Hz ≤ f ≤ 150Hz = Continuous: 0.5g / Occasional: 1.0g X, Y, Z directions for 10 times	
Weight	Approx. 95.5g	Approx. 116g

Input Point Electric Specifications

Input Type	DC (SINK or SOURCE)
Input Voltage	24VDC (5mA)
Active Level	Off → On, above 16VDC On → Off, below 14.4VDC
Response Time	Approx. 10ms

Output Point Electric Specifications

Output Type	Relay-R
Current Specifications	1.5A / 1 Point (5A/COM)
Voltage Specifications	250VAC, below 30VDC
Maximum Loading	75VA (Inductive)
	90 W (Resistive)
Response Time	Approx. 10 ms
Mechanical Life	2 × 10 ⁷ times (without load)

Output Point Electric Specifications

Electrical Life	100,000 times (3A 250VAC/30VDC) 6,000 times (5A 250VAC/30VDC)
-----------------	--

4 Installation & Wiring

4.1 Wiring

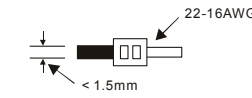

1. Please use the 28-16 AWG (1.5mm²) single-core bare wire (Solid type) or the multi-core wire (Stranded type) for the I/O wiring. The stripped length of the wire should be 6-7mm, and the torque specification of the screw for the terminal is 4.5lb-in. Please refer to the specifications of the terminal shown in the figure on the left.
2. DO NOT place the I/O signal wires and power supply wire in the same wiring duct.

4.2 Caution

Environment

1. DO NOT install the Extension Digital I/O Module in a place subjected to corrosive or flammable gases, liquids, or airborne dust or metallic particles.
2. DO NOT install the Extension Digital I/O Module in a location high temperature and high humidity (where temperature and humidity will exceed specification).
3. DO NOT install the Extension Digital I/O Module in a location where vibration and shock will exceed specification.

Wiring Note

1. Please avoid any conductive debris and tiny metal material enter the Extension Digital I/O Module when screwing and wiring.
2. Allow a minimum space of 50mm between the Extension Digital I/O Module and other control devices, and keep the Extension Digital I/O Module away from the high-voltage lines or any power equipment.

4.3 Input Point Wiring

There are two types of DC inputs, SINK and SOURCE, and they are defined as follows:

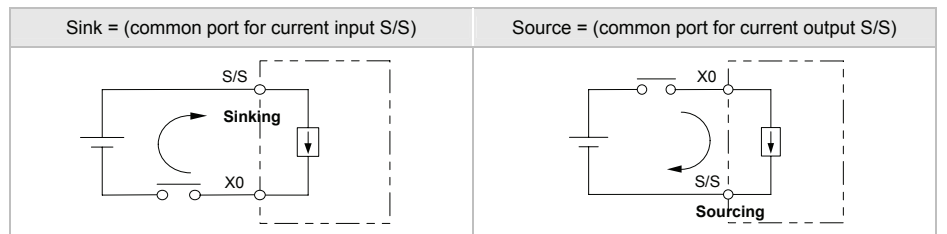

Wiring

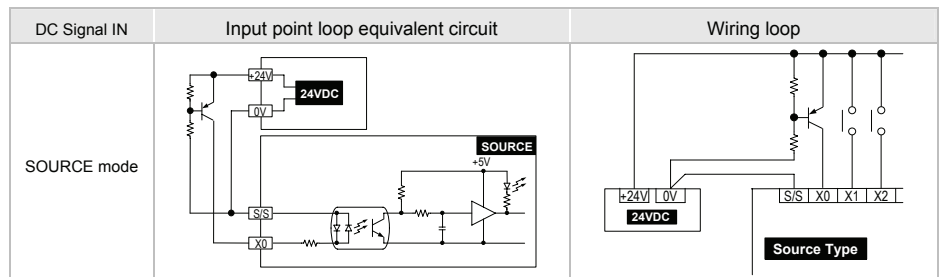
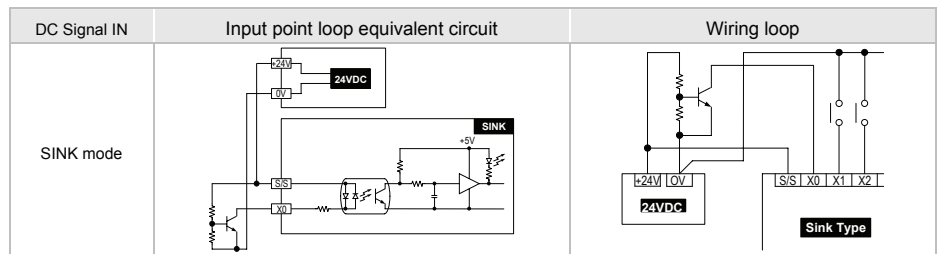

NOTE

- 1) The content of this instruction sheet may be revised without prior notice. Please consult our distributors or download the most updated version at <http://www.delta.com.tw/industrialautomation>.