

# BUE Series Brake Modules

## Instruction Sheet

### 1 Preface

Congratulations on your purchase of DELTA's brake module. BUE brake units are applied to absorb the motor regenerative energy when 3-phase induction motor stops by deceleration. With BUE brake unit, the regenerative energy is dissipated in the brake resistors. To prevent mechanical or human injury, please read this instruction sheet thoroughly before wiring.

BUE brake units are suitable for VFD-E/VFD-EL Series. BUE brake units need to be used in conjunction with BR series brake resistors to provide the optimum brake characteristics.

BUE brake units (20015 and 40015) are approved by Underwriters Laboratories, Inc. (UL) and Canadian Underwriters Laboratories (cUL). The content of this instruction sheet may be revised without prior notice, please consult our distributors or download the most updated version at <http://www.delta.com.tw/industrialautomation>.

### 2 Specifications

	115/230V Series		460V Series	
	BUE-20015	BUE-20037	BUE-40015	BUE-40037
Max. Motor Capacity (KW)	1.5	3.7	1.5	3.7
Output Rating	Max. Peak Discharge Current (A) 10%ED	3.6	16	1.8
	Brake Start-up Voltage (DC)	328/345/362/380/400±3V	656/690/725/760/800±6V	
Input Rating	DC Voltage	200~400VDC	400~800VDC	
	Heat Sink Overheat	Temperature over +100°C		
Protection	Power Charge Display	Blackout until bus (+~) voltage below 50VDC		
	Installation Location	Indoor (no corrosive gases, metallic dust)		
Environment	Operating Temperature	-10°C~+50°C		
	Storage Temperature	-20°C~+60°C		
	Humidity	90%R.H., Non-condensing		
	Vibration	9.8m/s <sup>2</sup> (1G) under 20Hz 2m/s <sup>2</sup> (0.2G) at 20~50Hz		
Mechanical Configuration	Wall-mounted enclosed type IP20			

### 3 Dimensions and Installations

#### 3.1 Brake resistor

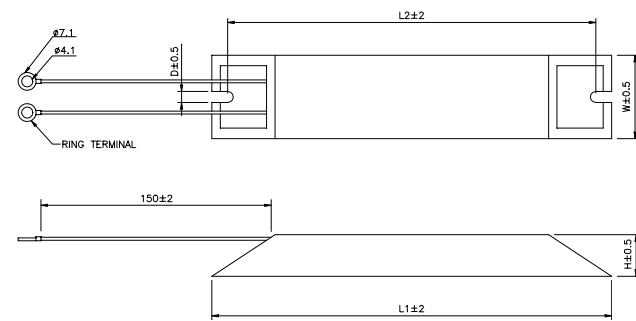

#### 3.2 Brake unit

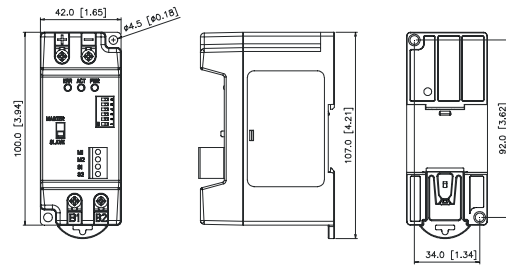

#### 3.3 DIN Rail Installation

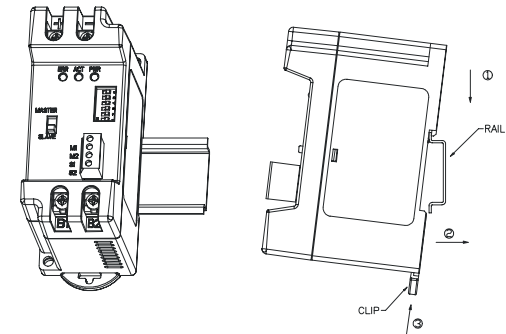

### 4 Outline and Wire Gauge

#### 4.1 Outline

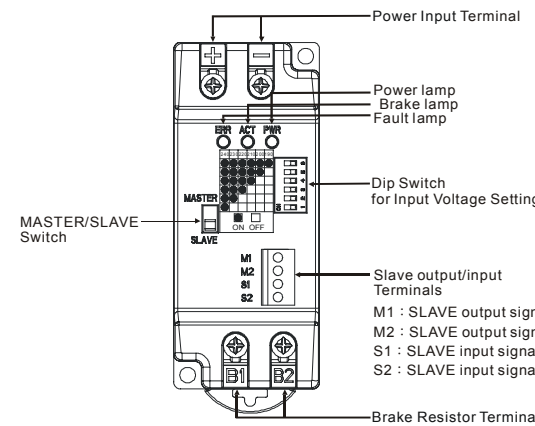

#### 4.2 Wire Gauge for Terminals

Circuit	Terminal Symbol	Wire Gauge AWG/mm <sup>2</sup>	Terminal
Power Input Circuit	+(P), -(N)	20~22AWG/0.5~0.3mm <sup>2</sup>	M4 Screw
Brake Resistor	B1, B2	20~22AWG/0.5~0.3mm <sup>2</sup>	M4 Screw
SLAVE Circuit	M1, M2 S1, S2	24AWG/0.2mm <sup>2</sup> M1, M2, S1, S2 with shielded wires	M2 Screw

### 5 Basic Wiring Diagram

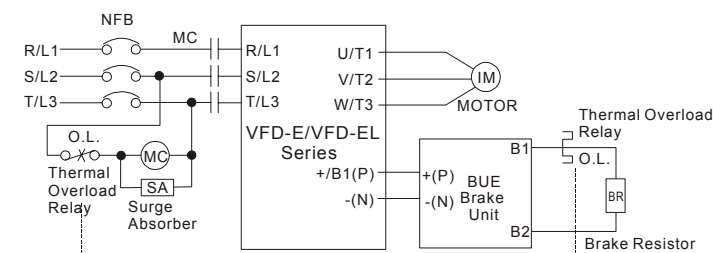

Note 1: When the AC drive uses with DC reactor, please refer to the wiring diagram in the VFD-E/EL user manual for wiring terminal +(P) of brake unit.  
Note 2: **DO NOT** wire terminal -(N) to neutral point of power system.

### NOTE

- For safety consideration, install an overload relay between the brake unit and the brake resistor. In conjunction with the magnetic contactor (MC) prior to the drive, it can perform complete protection against abnormality.
- The purpose of installing the thermal overload relay is to protect the brake resistor from damage due to frequent brake, or due to brake unit keeping operating resulted from unusual high input voltage. Under such circumstance, just turn off the power to avoid damaging the brake resistor.
- Please refer to "7 Brake Resistor/Units for the AC Drives" for the specification of the thermal overload relay.

### 6 Wiring Warnings

- Do not proceed with wiring while power is applied to the circuit.
- The wiring gauge and distance must comply with the local regulations.
- The +(P), -(N) terminals of the AC motor drive (VFD-E/VFD-EL Series), connected to the brake unit (BUE), must be confirmed for correct polarity lest the drive and the brake unit be damaged when power on.
- When the brake unit performs brake, the wires connected to +(P), -(N), B1 and B2 would generate a powerful electromagnetic field for a moment due to high current passing through. These wires should be wired separately from other low voltage control circuits lest they make interference or mis-operation

#### Wiring distance

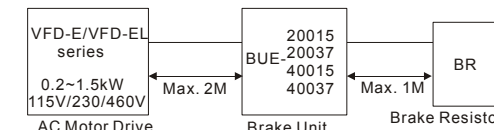

- Inflammable solids, gases or liquids must be avoided at the location where the brake resistor is installed. The brake resistor had better be installed in individual metallic box with forced air-cooling.
- Connect the ground terminal to the Earth Ground. The ground lead must be at least the same gauge wire as leads +(P), -(N).
- Please install the brake resistor with forced air-cooling or the equivalent when frequent deceleration brake is performed (over 10%ED).
- To avoid personal injury, do not connect/disconnect wires or regulate the setting of the brake unit while power on. Do not touch the terminals of related wiring and any component on PCB lest users be damaged by extreme dangerous DC high voltage
- We suggest to use ring terminals for main circuit wiring. Make sure the terminals are fastened before power on.

### 7 Brake Resistors/Units for Delta VFD AC Motor Drives Series

Voltage	Applicable Motor		Full-load output torque KG-M	Equivalent brake resistor for each AC drive	Brake Unit Model and Quantity	Brake Resistor Model and Quantity	Brake Torque 10% ED%	Min. Equivalent Resistor Value for Each AC Drive	Typical Thermal Overload Relay Value
	HP	kW							
115/230V Series	1/4	0.2	0.110	200W 250Ω	BUE20015 1	BR200W250 1	320	200Ω	2A
	1/2	0.4	0.216	200W 250Ω	BUE20015 1	BR200W250 1	170	100Ω	3A
	1	0.75	0.427	200W 150Ω	BUE20015 1	BR200W150 1	140	80Ω	4A
	2	1.5	0.849	300W 100Ω	BUE20015 1	BR300W100 1	107	80Ω	4A
	3	2.2	1.262	600W 50Ω	BUE20037 1	BR300W100 2	150	25Ω	12A
5	3.7	2.080	900W 30Ω	BUE20037 1	-	-	150	25Ω	12A
460V	1/2	0.4	0.216	300W 400Ω	BUE40015 1	BR300W400 1	400	400Ω	2A
	1	0.75	0.427	300W 400Ω	BUE40015 1	BR300W400 1	200	200Ω	3A
	2	1.5	0.849	400W 300Ω	BUE40015 1	BR200W150 1	140	160Ω	4A
	3	2.2	1.262	300W 400Ω	BUE40037 1	BR300W400 2	150	100Ω	6A
	5	3.7	2.080	900W 120Ω	BUE40037 1	-	-	100Ω	6A

### NOTE

- "-" means no Delta product. Please use the brake unit according to the Equivalent Resistor Value.
- The cycle time of brake usage ED% in the above table is 10 seconds.
- For the detail applicable models, refer to the following list:
  - BUE20015 is used for VFD002E11A/11P/11C/21A/21P/21C/23A/23P/23C, VFD004E11A/11P/11C/21A/21P/21C/23A/23P/23C, VFD007E21A/21P/21C/23A/23P/23C, VD015E23A/23P/23C, VFD002EL11A/21A/23A, VFD004EL11A/21A/23A, VFD007EL11A/21A/23A, VFD015EL21A/23A
  - BUE20037 is used for VFD022EL21A/23A, VFD037EL23A
  - BUE40015 is used for VFD004E43A/43P/43C, VFD007E43A/43P/43C, VFD015E43A/43C, VFD004EL43A, VFD007EL43A, VFD015EL43A
  - BUE40037 is used for VFD022EL43A, VFD037EL43A

### 8 Definition for the Brake Usage ED%

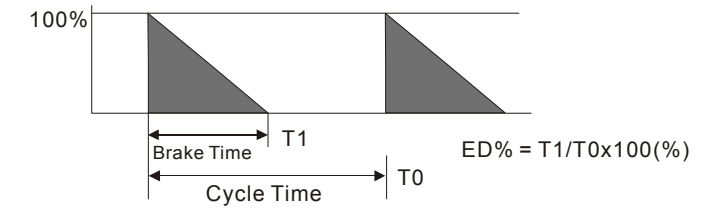

The definition of the brake usage ED(%) is to assure having enough time for the brake unit and brake resistor to dissipate the heat generated by brake. When the brake resistor heats up, the resistance would increase with temperature, and brake torque would decrease accordingly.

### 9 The Voltage Settings

The power source of the brake unit is the DC power from the +(P) and -(N) terminals of the AC motor drive. Therefore, it is an important step to set the voltage by the input voltage of the AC motor drive before operation. This setting will affect the voltage level of the brake unit.

Table 1: The voltage selection and operation level of the PN DC voltage

115V/230V Model AC Power Voltage	Brake Start-up voltage DC Bus +(P), -(N)) Voltage	460V Model AC Power Voltage	Brake Start-up voltage DC Bus +(P), -(N)) Voltage
190Vac	330Vdc	380Vac	660Vdc
200Vac	345Vdc	400Vac	690Vdc
210Vac	360Vdc	420Vac	725Vdc
220Vac	380Vdc	440Vac	760Vdc
230Vac	400Vdc	460Vac	800Vdc

NOTE: Input Power With Tolerance ±10%

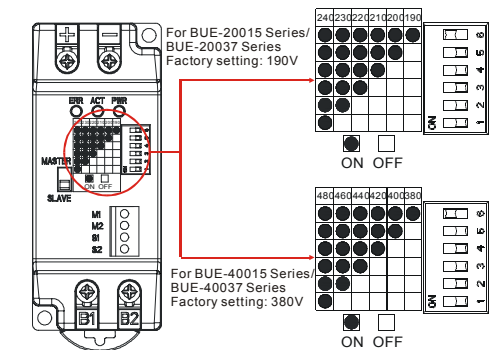

### NOTE

- Before setting the voltage, make sure the power has been turned off.
- Please set power voltage as the possible highest voltage for unstable power system. Take 380VAC power system for example. If the voltage may be up to 410VAC, 415VAC should be selected.
- For VFD-E/VFD-EL Series, please set parameter Pr06.00=0 (Over Voltage Stall Prevention) to disable over-voltage stall prevention, to ensure stable deceleration characteristic.

# BUE 系列煞車模組 說明書

## 1 前言

感謝您選用台達 BUE 動力制動煞車模組。BUE 制動單元主要應用於當三相感應馬達由交流馬達驅動器所驅動，在減速停止時用以吸收由馬達側所回生的能量，藉由 BUE 制動單元將此能量以熱能的方式消耗在煞車電阻上。本產品在安裝使用前，請詳細參閱使用手冊的說明再進行施工配線，以免造成機械或人員的傷害。  
BUE 動力制動煞車模組適用於本公司 VFD-E/VFD-EL 系列的交流馬達驅動器。BUE 制動單元需搭配煞車電阻 BR 系列，才能發揮優異的制動特性，詳細的規格及使用方法請繼續參閱本使用說明書。由於產品精益求精，當內容規格有所修正時，請洽詢代理商或至台達網站 (<http://www.delta.com.tw/industrialautomation/>) 下載最新版本。

## 2 制動單元規格

使用電壓等級	115/230V 級		460V 級	
型號 BUE-XXXXX	20015	20037	40015	40037
最大適用馬達容量 (kW)	1.5	3.7	1.5	3.7
輸出額定	最大放電電流 (A peak) 10ED%		最大放電電流 (A peak) 10ED%	
額定	3.6	16	1.8	8
制動起始電壓 (DC)	328/345/362/380/400±3V		656/690/725/760/800±6V	
電源	直流電壓 200—400VDC		400—800VDC	
保護	散熱片過熱 溫度開關 +100°C			
	充電中顯示 主回路 (P-N) 電壓在 50VDC 以下熄滅			
使用環境	安裝場所 屋內 (無腐蝕性氣體、金屬粉塵)			
	環境溫度 -10°C ~ +50°C			
	儲存溫度 -20°C ~ +60°C			
	濕度 90%RH 以下不結露			
	振動 20Hz 以下 9.8m/S <sup>2</sup> (1G)、20~50Hz 2m/S <sup>2</sup> (0.2G)			
機構構造	閉掛型 IP20			

## 3 外型尺寸及 DIN Rail 安裝

### 3.1 煞車電阻

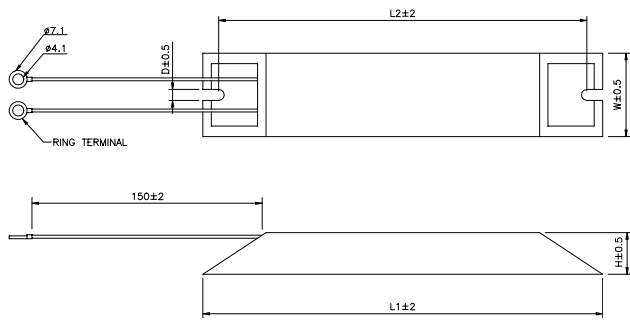

TYPE	L1	L2	H	D	W	MAX. WEIGHT(g)
BR080W200	140	125	20	5.3	60	160
BR080W750	140	125	20	5.3	60	160
BR300W400	215	200	30	5.3	60	750

### 3.2 制動單元

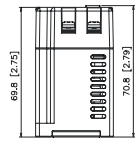
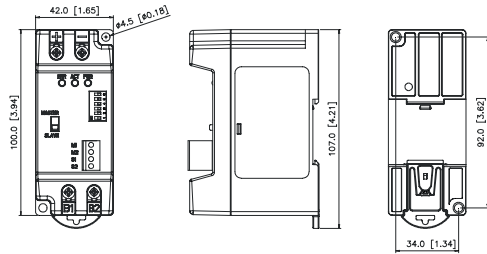

### 3.3 DIN Rail 安裝

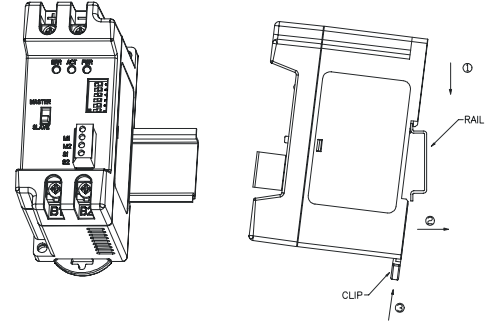

## 4 各部名稱及功能說明

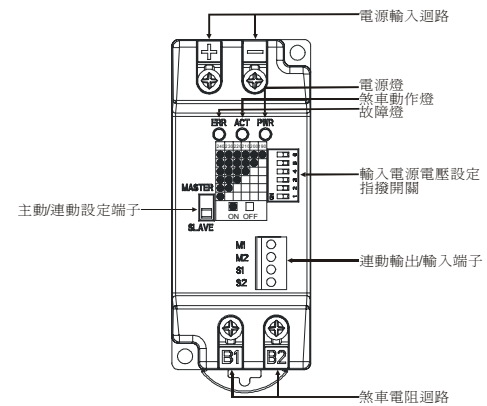

### 4.1 各端子使用線徑

回路名稱	端子記號	導線線徑 AWG/mm <sup>2</sup>	端子規格
電源輸入回路	+ (P) 、 - (N)	20~22AWG/0.5~0.3mm <sup>2</sup>	M4
煞車電阻回路	B1、B2	20~22AWG/0.5~0.3mm <sup>2</sup>	M4
連動回路	M1、M2 S1、S2	24AWG/0.2mm <sup>2</sup> M1.M2.S1.S2 需用隔離線	M2

## 5 基本配線圖

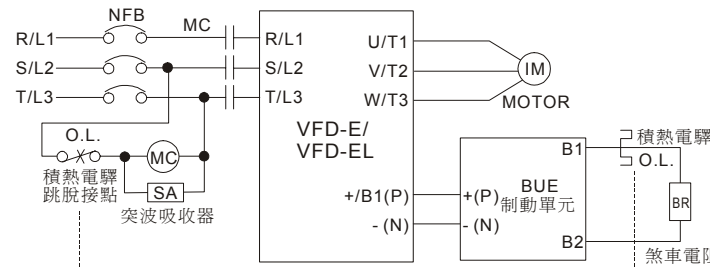

- 當交流馬達驅動器有安裝直流電抗器 (DC Choke) 時，其煞車模組之電源輸入迴路 + (P) 端的配線方法，可參考交流馬達驅動器手冊。
- 請勿將電源輸入迴路 - (N) 端，接至電力系統之中性點。

## NOTE

- 在安裝制動單元的應用中為了安全的考量，在制動單元與煞車電阻之間加裝一積熱電驛 (O.L.)；並與交流馬達驅動器前端的電磁接觸器 (MC) 作一連鎖的異常保護。
- 加裝積熱電驛的主要目的是為了保護煞車電阻不因煞車頻繁過熱而燒毀，或是因輸入電源電壓異常過高導致制動單元連續導通燒毀煞車電阻。此時只有將交流馬達驅動器的電源關閉才可避免煞車電阻燒毀。
- 積熱電驛規格的選用請參考制動單元與放電電阻適用一覽表。
- 配線電路在電源開關 (NFB) 開啓時交流馬達驅動器與制動單元便同時通上電源，馬達的運轉/停止的方式請參考 VFD-E/VFD-EL 系列的使用手冊；制動單元會在交流馬達驅動器對馬達作減速煞車時自動偵測交流馬達驅動器內部的直流電壓，自動將過多的再生能量藉由煞車電阻以熱能的方式迅速消耗以達平穩的減速特性。

## 6 配線注意事項

- 進行配線施工時務必確認相關回路電源均為關閉狀態下始可進行。
- 配線的線徑及距離務必按照規定選用及施工。
- 交流馬達驅動器 (VFD-E/VFD-EL) 連接至制動單元 (BUE) 的 + (P) 、 - (N) 端子有極性之分千萬要確認再確認，否則電源一開啓制動單元立即炸毀請務必注意。
- 制動單元在執行煞車時，+ (P) 、 - (N) 、 B1 、 B2 因有大電流通過所連接的導線瞬間將產生能量很大的電磁場；故在初期配線施工規劃時應與其它低電壓的控制線路分離配線以免造成不必要的干擾或誤動作。
- 配線距離

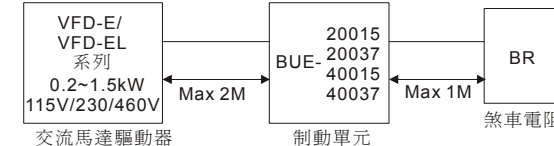

- 煞車電阻安裝的場所不能有任何易燃性的物體、氣體、液體，最好能安裝在獨立的金屬箱內並加以風扇散熱。
- 制動單元的接地工程 230V 級請依第三種接地施工，460V 級請依特別第三種接地施工。
- 在減速煞車頻繁的場合 (超過 10ED%) 煞車電阻請加裝風扇強制風冷或其它冷卻設備。
- 在通電中嚴禁修改任何配線及制動單元內部設定，更嚴禁在通電中碰觸相關配線的端子及 PCB 板中的任一元件，以免因通電中遭極度危險的直流高壓感電造成人員傷害。
- 所有的主回路端子請使用 O 型端子配線，並確認端子已鎖緊方可送電運行。

## 7 制動單元與煞車電阻適用一覽表

電壓	適用馬達		每交流馬達驅動器等效煞車電阻規格	制動單元型式 BUE 用量	煞車電阻料號用量	制動轉矩 10% ED	每交流馬達驅動器等效最小電阻值	積熱電驛規格中心值		
	HP	kW								
115/230V 系列	1/4	0.2	0.110	200W 250Ω	BUE20015 1	BR200W250 1	320	200Ω	2A	
	1/2	0.4	0.216	200W 250Ω	BUE20015 1	BR200W250 1	170	100Ω	3A	
	1	0.75	0.427	200W 150Ω	BUE20015 1	BR200W150 1	140	80Ω	4A	
	2	1.5	0.849	300W 100Ω	BUE20015 1	BR300W100 1	107	80Ω	4A	
	3	2.2	1.262	600W 50Ω	BUE20037 1	BR300W100 2	150	25Ω	12A	
460V	5	3.7	2.080	900W 30Ω	BUE20037 1	-	-	150	25Ω	12A
	1/2	0.4	0.216	300W 400Ω	BUE40015 1	BR300W400 1	400	400Ω	2A	
	1	0.75	0.427	300W 400Ω	BUE40015 1	BR300W400 1	200	200Ω	3A	
	2	1.5	0.849	400W 300Ω	BUE40015 1	BR200W150 1	140	160Ω	4A	
	3	2.2	1.262	300W 400Ω	BUE40037 1	BR300W400 2	150	100Ω	6A	
5	3.7	2.080	900W 120Ω	BUE40037 1	-	-	150	100Ω	6A	

## NOTE

- 制動電阻料號中“-”代表台達未提供標準料號，請依台達建議等效煞車電阻規格訂製所需求之煞車電阻。
- 上表中的 ED% 的週期時間是以 10 秒計算。
- 詳細適用機種，請參考以下列表。
  - BUE20015 適用於 VFD002E11A/11P/11C/21A/21P/21C/23A/23P/23C, VFD004E11A/11P/11C/21A/21P/21C/23A/23P/23C, VFD007E21A/21P/21C/23A/23P/23C, VD015E23A/23P/23C, VFD002EL11A/21A/23A, VFD004EL11A/21A/23A, VFD007EL11A/21A/23A, VFD015EL21A/23A
  - BUE20037 適用於 VFD022EL21A/23A, VFD037EL23A
  - BUE40015 適用於 VFD004E43A/43P/43C, VFD007E43A/43P/43C, VFD015E43A/43C, VFD004EL43A, VFD007EL43A, VFD015EL43A
  - BUE40037 適用於 VFD022EL43A, VFD037EL43A

## 8 煞車使用率 ED% 的定義

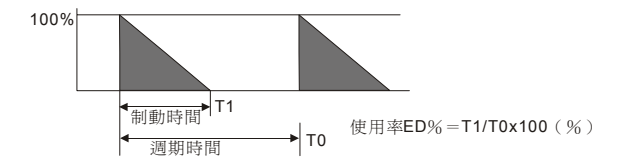

制定煞車使用率 ED%，主要是為了能讓制動單元及煞車電阻有充份的時間來散除因制動而產生的熱量；當煞車電阻發熱時，電阻值將會隨溫度的上昇而變高，制動轉矩亦隨之減少。

## 9 設定與調整

制動單元的電力來源是接受交流馬達驅動器 + (P) 、 - (N) 兩端供應的直流電源。因此，在配線完成準備運轉時，依交流馬達驅動器的輸入電源來設定制動單元的電源電壓是非常重要的步驟；此設定將會影響制動單元動作電壓的位準，下表為各個電壓動作準位。

表一：電源電壓的選擇與 PN 直流電壓的動作準位

115V/230V 級 AC 電源電壓	制動開始電壓 + (P) 、 - (N) 母線 DC 電壓	460V 級 AC 電源電壓	制動開始電壓 + (P) 、 - (N) 母線 DC 電壓
190Vac	330Vdc	380Vac	660Vdc
200Vac	345Vdc	400Vac	690Vdc
210Vac	360Vdc	420Vac	725Vdc
220Vac	380Vdc	440Vac	760Vdc
230Vac	400Vdc	460Vac	800Vdc

註：容許輸入電源有 ±10% 的變動

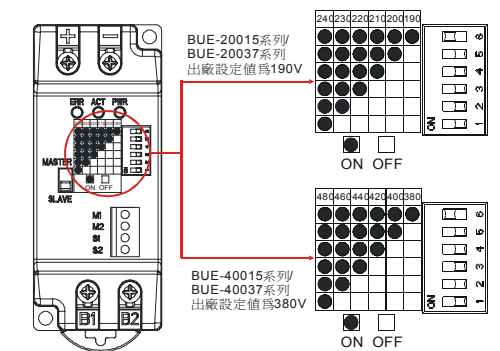

## NOTE

- 設定電源電壓時請務必先將電源關閉後才可更改設定值。
- 若在電源電壓不穩定的區域，請將電源電壓設定在可能出現的最高電壓。例如：380Vac 的電源系統，若電壓變動達到 410Vac 請設定在 420Vac。
- 使用本公司 VFD-E/VFD-EL 系列交流馬達驅動器，請將參數的過電壓失速防止功能設定為關閉狀態，使失速防止功能失效，如此可得穩定的減速特性。