

DE-620 ETHERNET POCKET ADAPTER TROUBLESHOOTING GUIDE

This Document Refers to the following models:

DE-620	BNC connector
DE-620TP	UTP connector
DE-620CT	BNC & UTP connector
DE-621	Duplexer to support printer port (discontinued product)

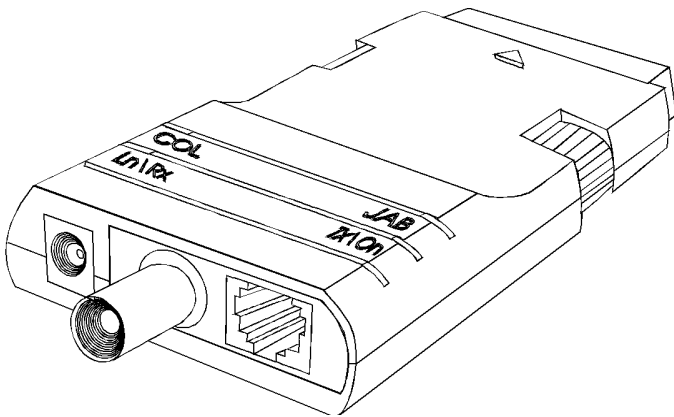

Specification

D-Link DE-620 pocket adapter is designed to enable notebooks or other computers to connect to an Ethernet network through the Parallel Port. It supports unidirectional, bi-directional or EPP type ports (version 1.7 specification). **Power** is taken from a 12volt power supply or, on latest models, from the keyboard port. The keyboard port connector is only designed to be used on later models, as supplied; earlier models may work but tend to overload both the notebook and the adapter itself (overheat)-so it's not recommended.

Current Disk Release

Check the date on your own diskette: the date is stamped on the diskette.. Make sure it is at least 1996- download a later release if necessary. This particularly applies to newer Toshiba, IBM Thinkpad & other models. [Drivers are located in: FTP: \pub\adapters\de620\ BBS: DE620 library]

Installation

When first installing the DE-620 it is essential to check out the correct functioning of the unit first. To do this attach to your computer's parallel printer port, turn on the power supply and power up the computer. After booting, insert the D-LINK Drivers Disk into the floppy drive and run the diagnostic/setup program (SETUP620.EXE in A:\UTILITY directory) -or copy onto your hard disk.

For the DE-620CT model you MUST set the cable type in the EEPROM. The adapter does not auto-detect the cable type and failure to set correctly will not allow you to connect to the network at all.

If an error is reported by the diagnostic program such as not being able to find the adapter, or 'RAM test fail' please access the BIOS setup of your notebook to find out, and if needed, change - the mode used. The following are the most common:-

Uni-directional Mode

This mode is equivalent to the original Centronics/IBM Parallel Port standard. Since it supports only output (to a printer normally) input is done through software and so slightly slower than Bi-directional (see below).

Bi-directional Mode

This standard originated from the IBM PS/2 computer. If bi-directional mode is supported by your notebook then the speed increase should be about 10%. Not all ports are completely compatible with the DE-620 so if you can't get it to work please revert to Uni-directional mode.

EPP Mode

DE-620 series adapters support version 1.7 EPP specification. This means you may achieve up to 4 times the throughput of either uni-directional or bi-directional ports. Unfortunately the Compaq Aero (and others) uses 1.9 EPP and is not backward compatible with DE-620's [and some other vendors' products] EPP mode. There are no plans at present to use version 1.9 EPP. If after setting EPP mode the DE-620 setup program still detects Uni/Bi direction, it will probably not support EPP on your computer.

Most notebooks enable EPP either with a device driver / utility or some change in the CMOS. For example Compaq requires the LPT port to be set to LPT2 to enable EPP, AST have a utility available. Consult your manual on how to enable EPP.

ECP Mode

This type of parallel port is becoming more common to support very high speed transfer. Unfortunately it is not suited to network devices such as the D-Link DE-620. If your notebook uses ECP please try to disable and set to Standard, bi-directional or EPP instead. Most recent notebook models have this kind of port (see note above)

Select the fastest mode which will work reliably.

Problem Solving

Error message: 'RAM test failure'

- this may mean the notebook cannot recognise the adapter
- this may mean the notebook's printer port is incompatible
- this may mean the PSU does not work or is not switched on

Error message 'A file server could not be found' or no connectivity in other NOS

- this may be because the incorrect connector was selected [for DE-620CT only]
- this could be due to frame type inconsistency with Netware [802.2/802.3]
- this could be due to over-length cabling [185m coax/100m UTP]

The MAC address is invalid or incorrect

all D-Link DE-620 adapters have a unique address starting with 00.80.C8... You can see this on the label of the product. The setup/diagnostic program will identify this address **please make sure it matches the one on the label**. If the address is incorrect or (more seriously) zeros there may be a fault. Contact technical support for advice about this.

LEDs: check that Transmit and Receive LEDs are blinking when attempting find the server. For UTP the Ln (LINK) LED should be on when cable attached, off when removed. (You can also check the hub LINK LED which operates in the same manner but on its own cable pair)

COLlision May be active from time to time but not constantly.
The more network traffic the more times this will light

JABber Should never be active. If this led is active suspect a problem with the adapter

Ln/Rx Link will be on when you attach the UTP cable (not BNC)
Receive will flicker when traffic is being received from the network

Tx/On Transmit will flicker when traffic is being sent to the network
On will be active whenever the adapter is powered

Compatibility problems

In cases of severe compatibility you may have to use an alternative device. If you are fortunate enough to have a PCMCIA Type II slot you'll be able to use the **D-Link DE-650CT or DE-660CT** PCMCIA Ethernet card.

We have found that incorrect functioning of the D-Link DE-620 range of products may have three reasons:-

THE PRINTER PORT IS INCOMPATIBLE OR NOT FUNCTIONING CORRECTLY

While the DE-620 works on 99+% of notebooks, there are some which have problems. - please check with the manufacturer of the notebook for further information.

THE DRIVERS ARE OUT OF DATE

The drivers have been updated regularly in the last 2 years to enhance compatibility and performance. Make sure you are using the latest

THE DE-620CT CAN'T BE SET TO THE CORRECT CABLE TYPE

If this occurs you may need to reset the EEPROM using SETUP620 /F option.

THE ADAPTER IS FAULTY

Occasionally a DE-620 has a definite problem. In this instance, contact D-Link or your dealer as stated above.

DE-621 DUPLEXER

This optional product allows printing to a local printer alongside the DE-620 adapter. It is important to use the latest drivers for the DE-620 and **not** those that were shipped with the DE-621.

USING WINDOWS 3.1x WITH THE DE-620 ADAPTER

Microsoft have published notes on using Windows as follows:

*'Device Contention Errors with Parallel Port Network Cards
Article ID: Q90926*

SYMPTOMS

If you use Windows for Workgroups with a network interface card (NIC) that plugs into the parallel port, device contention errors may occur. (Only two supported NICs plug into the parallel port: the Xircom Pocket Ethernet I and II.)

CAUSE

These errors occur because Windows for Workgroups sees the LPT port as being used by two different resources: the network and the printer.

WORKAROUND

To work around this problem, do one of the following:

Workaround 1

If you do not need the LPT port for local printing, you can disable the check for device contention by removing the following line in the SYSTEM.INI file:

```
DEVICE=VPD.386
```

Disabling VPD.386 doesn't affect the ability of Windows for Workgroups to print over the network. However, if you are printing locally, no warning appears and printouts may have garbled characters, or you may experience network communication problems.

Workaround 2

In Control Panel, choose the 386 Enhanced Mode icon. Set the Idle Time for the port in question to zero (0). This turns off VPD trapping for that port.

MORE INFORMATION

For more information on device contention in Windows, query on the following words in the Microsoft Knowledge Base:

device contention windows

This section copyright 1993 Microsoft Corporation.

USING WINDOWS 95 WITH THE DE-620 ADAPTER

D-Link have drivers for Windows 95 on the BBS/FTP server: 95-620.ZIP in DE620 library or in the \WIN95 directory of the complete diskette file: DE620.ZIP. See the README text file for installation.