

COMPAQ

***Netelligent 1124
100Base-TX Repeater***

User Guide

NOTICE

The information in this publication is subject to change without notice.

COMPAQ COMPUTER CORPORATION SHALL NOT BE LIABLE FOR TECHNICAL OR EDITORIAL ERRORS OR OMISSIONS CONTAINED HEREIN, NOR FOR INCIDENTAL OR CONSEQUENTIAL DAMAGES RESULTING FROM THE FURNISHING, PERFORMANCE, OR USE OF THIS MATERIAL.

This publication contains information protected by copyright. No part of this publication may be photocopied or reproduced in any form without prior written consent from Compaq Computer Corporation.

The software described in this guide is furnished under a license agreement or non disclosure agreement.

The software may be used or copied only in accordance with the terms of the agreement.

Product names mentioned herein may be trademarks and/or registered trademarks of their respective companies.

© 1996 Compaq Computer Corporation.
All rights reserved. Printed in the U.S.A.

Compaq Netelligent 1124 100Base-TX Repeater User Guide

First Edition (March 1996)
Part Number 185810-001

Federal Communications Commission Notice

This equipment has been tested and found to comply with the limits for a Class A digital device, pursuant to Part 15 of the FCC Rules. These limits are designed to provide reasonable protection against harmful interference when the equipment is operated in a commercial environment. This equipment generates, uses and can radiate radio frequency energy and, if not installed and used in accordance with the instructions in this manual, may cause interference to radio communications. Operation of this equipment in a residential area is likely to cause harmful interference in which case the user will be required to correct the interference at his own expense.

Class A devices bear a label indicating the interference potential of the device as well as additional operating instructions for the user, such as the following: This device complies with Part 15 of the Federal Communications Commission (FCC) Rules. Operation is subject to the following two conditions: (1) This device may not cause harmful interference, and (2) this device must accept any interference received, including interference that may cause undesired operation.

Canadian Department of Communications Radio Frequency Statement

This digital apparatus does not exceed the Class A limits for radio noise emissions from digital apparatus set out in the Radio Interference Regulations of the Canadian Department of Communications.

Le présent appareil numérique n'émet pas de bruits radioélectriques dépassant les limites applicables aux appareils numériques de la classe A prescrites dans le Règlement sur le brouillage radioélectrique édicté par le ministère des Communications du Canada.

Modifications

The FCC requires the user to be notified that any changes or modifications made to this device that are not expressly approved by Compaq Computer Corporation may void the user's authority to operate the equipment.

Emissions

This equipment complies with EMC directive 89/336/EEC (ITE), which includes EN50081-1 CLASS 1: 1992 (EN55022/CISPR 22 for Class A ITE). It also complies with FCC Class A.

European Union Notice

Products with the CE (Community European) Marking comply with both the EMC Directive (89/336/EEC) and the Low Voltage Directive (73/23/EEC) issued by the Commission of the European Community.

Compliance with these directives implies conformity to the following European Norms:

- EN55022 (CISPR 22) - Electromagnetic Interference
- EN50082-1 (IEC801-2, IEC801-3, IEC801-4) - Electromagnetic Immunity
- EN60950 (IEC950) - Product Safety

Safety

This equipment complies with UL 1950, Second Edition; CAN/CSA C22.2 No. 950-93, 73/23/EEC Low Voltage Directive; TUV Rheinland EN60950, 1988; A1/1990, 1993; and A2/1992, 1992, 1993.

Immunity

This equipment complies with EMC directive 89/336/EEC (ITE), which includes EN 50082-1:

- IEC 801-2 (Electrostatic Discharge)
 - IEC 801-3 (Radiated Immunity)
 - IEC 801-4 (Electrical Fast Transient/Burst)
 - EN55101-4 (Conducted Immunity) (not currently required)
-

Contents

Preface

Intended Reader	ix
Organization of Contents	ix

Chapter 1

Introduction

Features	1-1
Package Contents	1-2
Operational Overview	1-4
LED Indicators	1-5
RJ-45 Ports	1-7
Uplink Switch	1-7

Chapter 2

Planning Repeater Installation

Installation Requirements	2-1
Environmental Requirements	2-1
Electrical Requirements	2-1
Spatial Requirements	2-2
Twisted-Pair (UTP) Wired Requirements	2-2
Installing New Wire	2-3
System Planning Charts	2-5

Chapter 3

Installing the Repeater

Mounting the Repeater	3-1
Attaching Rubber Feet	3-1
Rack-Mounting the Repeater	3-1
Connecting Twisted-Pair Cable	3-3

Setting the Uplink Switches	3-3
Interconnecting Repeaters	3-4
Connecting Power	3-5
Disconnecting Power	3-7
Replacing the Power Supply	3-7
Installing a Redundant Power Supply Module	3-7

Appendix A

Specifications

Electrical Specifications	A-1
Physical Specifications	A-2
Environmental Specifications	A-2

Glossary

Preface

This guide includes information about how to install and operate the Compaq Netelligent 1124 100Base-TX Repeater.

We recommend that you read all chapters in this guide to become familiar with all of the repeater's features and to ensure a successful installation.

Intended Reader

This guide is written for network administrators and technicians responsible for hardware installation.

Organization of Contents

The contents of this guide are organized as follows:

Chapter 1 — Provides an operational overview of the repeater and describes its components and features.

Chapter 2 — Discusses special requirements for operating the repeater and provides charts that can help you plan the installation of the repeater.

Chapter 3 — Provides instructions for mounting the repeater, connecting cable, interconnecting the repeater to another repeater, and connecting power to the repeater. Also included are instructions for installing a redundant power supply module.

Appendix A — Includes the repeater's electrical, physical, and environmental specifications.

Glossary — Provides terms related to the repeater, as well as general networking terms.

Chapter 1

Introduction

Compaq's Netelligent 1124 100Base-TX Repeater provides functionality for 24 RJ-45 ports. The repeater's uplink capability lets you connect the repeater to another repeater or other 100Base-TX repeater. For backup power, you can install an optional redundant power supply. The repeater's front panel makes it easy to view the current operating status.

Features

The repeater includes these features:

- Twenty-four shielded RJ-45 ports that support 100Base-TX connections
- Uplink port that enables bridging to 100Base-TX topologies
- LEDs that indicate power supply status (A and B), collisions, and port link/activity/partition status
- Modular power supply design for easy removal and replacement
- Auto-sensing power supply operates within the range of a 100 to 240 VAC, 50 to 60 Hz power source
- Optional dual-redundant power supply
- Class II support for 100Base-TX
- Compatibility with the IEEE 802.3u 100Base-TX repeater specification
- Chassis that can stand alone or be mounted in a standard, EIA 19-inch rack
- Surface-mount technology

Package Contents

Before you start to install the repeater, verify that this package contains the following items:

- 1124 100Base-TX Repeater (Part Number 267024-001)
 - AC power cord
 - Rack-mounting kit (two mounting brackets, eight 3/8-inch bracket screws, and four 1/2-inch rack-mount screws)
 - Four adhesive-backed rubber feet
 - *Compaq Netelligent 1124 100Base-TX Repeater User Guide*
 - Warranty card
-

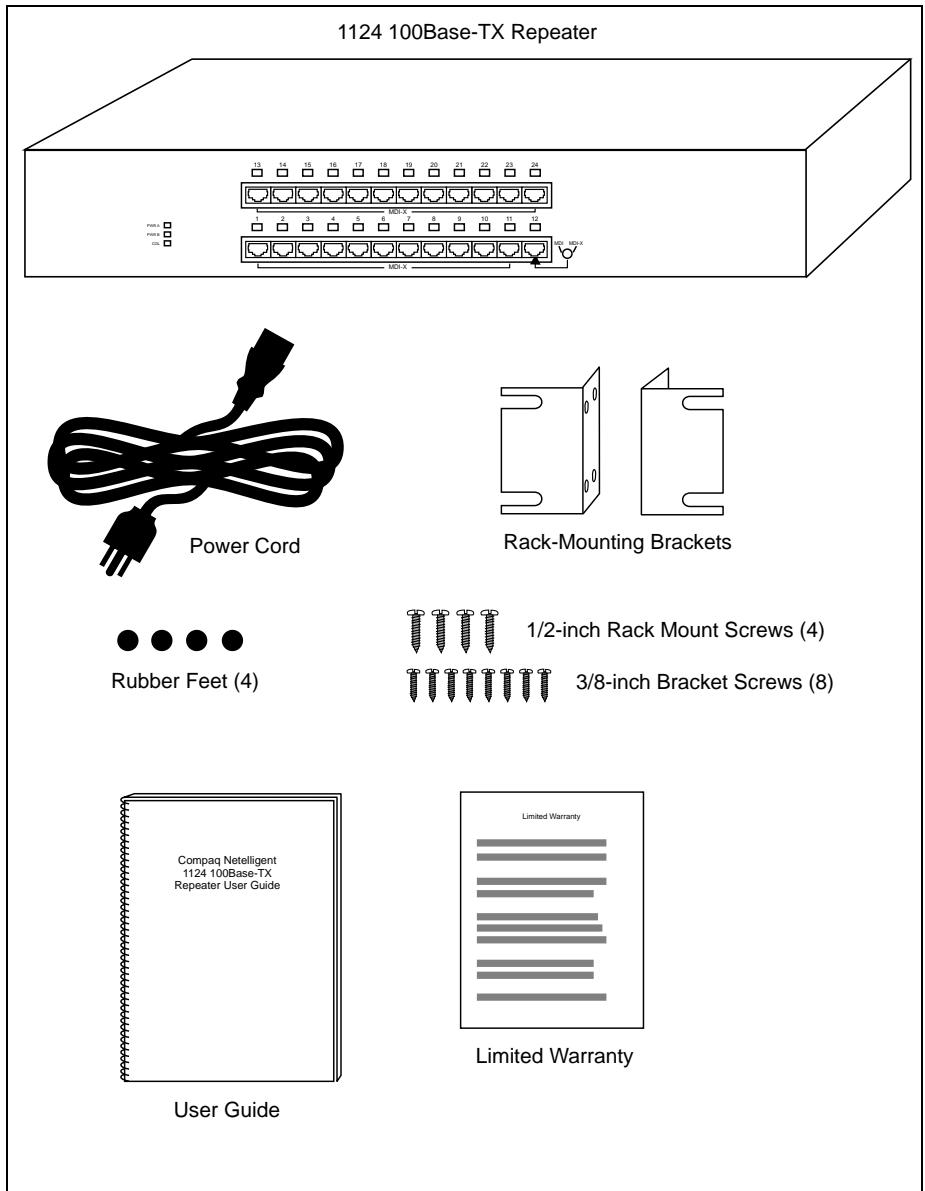

Figure 1-1. Package Contents

Operational Overview

This section provides an overview of the repeater's components, which include the LED indicators, RJ-45 ports, and uplink ports, and discusses the basic functionality of the repeater. Figures 1-2 and 1-3 show the repeater's front and back panel.

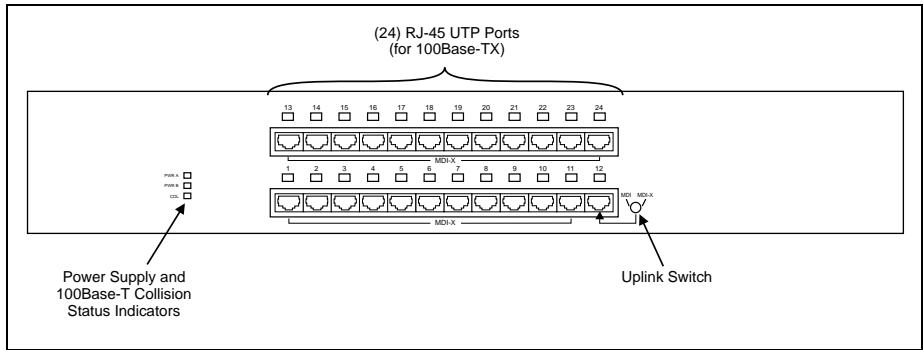

Figure 1-2. Repeater Front Panel

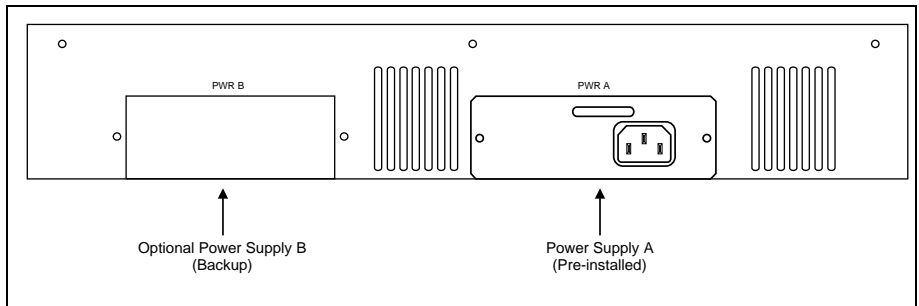

Figure 1-3. Repeater Back Panel

LED Indicators

The repeater features several LED indicators that help you monitor the repeater's status.

- The LEDs on the left side of the front panel show the status of the power supplies as well as the 100Base-TX collision status.
- The LEDs above the RJ-45 ports indicate the link, activity, and partition status for each of the ports.

Figure 1-4 shows the LED arrangement for the repeater; Table 4-1 describes the functions of the LEDs.

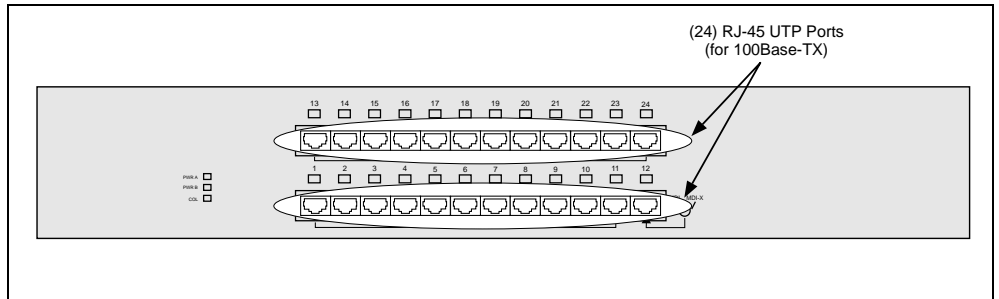

Figure 1-4. LED Indicators

Chapter 2

Planning Repeater Installation

This chapter contains installation requirements and system planning charts that will help you prepare for installing the repeater.

Installation Requirements

To help ensure a correct installation, read this section to determine the environmental, electrical, spatial, and cable requirements.

Environmental Requirements

Be sure the operating environment for the repeater is within the following ranges:

- Temperature: 32° to 122° F (0° to 50° C)
- Humidity: 5% to 95% (non-condensing)
- Altitude: 0 to 10,000 feet (0 to 3 km)
- Clearance: minimum of 2 inches (5.1 centimeters) on each side of the repeater for proper ventilation

Electrical Requirements

The electrical requirements for a repeater are as follows:

- 100 to 240 VAC
- 1.5 to 0.75 Amps (1.5 Amps @ 100 VAC to 0.75 A @ 240 VAC)
- 50 to 60 Hz



CAUTION: The power outlet must be a non-switched, three-pronged, grounded outlet. Do not use a three-to-two pronged adapter at the outlet. Doing so may result in electrical shock and/or damage to the repeater and will void your warranty.

NOTE: If the supplied power cord is lost or damaged, replace it with a power cord of the same type and current rating (10 A). The replacement cord should also meet required regulatory approvals to ensure emissions compliance.

Spatial Requirements

The repeater's dimensions are 3 x 16.95 x 14 inches, 7.62 x 43.05 x 35.56 cm (HxWxD).

You can interconnect two repeaters. If there is not enough space to mount the repeaters in a single rack or stack them on a single shelf, or if you want to place the repeaters in different locations, you can place them on separate shelves or in separate racks. See “Twisted-Pair (UTP) Wire Requirements” in this chapter for more information.

Be sure to allow at least 2 inches (5.1 centimeters) on each side of the repeater for proper air circulation and cable connections.

Twisted-Pair (UTP) Wire Requirements

The twisted-pair wiring you use to connect the repeater's RJ-45 ports must meet the following minimum specifications and requirements to ensure long-term reliability.

- The wiring must be unshielded twisted-pair (UTP) Category 5.
 - Two pairs of the four-pair wiring are used for signalling.
 - Depending on building codes, different insulation materials may be required. Plenum-rated or TEFLON-coated wiring may be required in some areas.
 - The wire gauge should be between 18 and 26 AWG. (Most telephone installations use 24-gauge wiring.)
-

- Solid copper

Installing New Wire

If you are installing the repeater where no wiring is present, or if existing wiring does not meet the above specifications, install new wiring. The new wiring should conform to national and local electrical wiring code requirements and meet the above specifications. When installing wire, it is a good idea to install extra pairs of wire for future expansion.

If you are unfamiliar with wiring installation or the applicable local electrical wiring code or the 100Base-TX specification, you should have a professional, licensed (if applicable) installer perform the installation.

Straight-through twisted-pair cable is typically used to connect a repeater to a server or workstation. In a straight-through connection, Pin 1 at the repeater connects to Pin 1 at the server, Pin 2 at the repeater connects to Pin 2 at the server, and so on. Figure 2-1 shows the locations of pins on a standard RJ-45 plug on a twisted-pair cable.

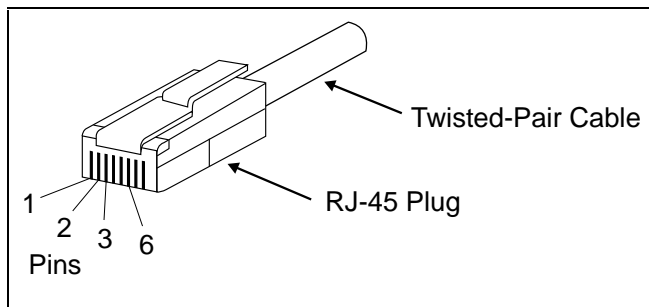

Figure 2-1. RJ-45 Plug

Tables 2-1 and 2-2 describe the wiring in a straight-through and crossover twisted-pair cable.

Table 2-1
Straight-Through Twisted-Pair Wiring

Twisted Pair Number	Pin Number	Signal Description	To	Pin Number	Signal Description
1	1	TD+	→	1	TD+
	2	TD-	→	2	TD-
2	3	RD+	→	3	RD+
	6	RD-	→	6	RD-

Table 2-2
Crossover Twisted-Pair Wiring

Twisted Pair Number	Pin Number	Signal Description	To	Pin Number	Signal Description
1	1	TD+	→	3	RD+
	2	TD-	→	6	RD-
2	3	RD+	→	1	TD+
	6	RD-	→	2	TD-

System Planning Charts

The charts in Figures 2-2 and 2-3 provide a convenient way of planning the connections for your repeater.

100Base-TX Repeater Setup and Cabling Chart

Date

Unit Number

Building

Location

Rack Mount

Table

Uplink Switch Setting

MDI-X (default)

MDI (uplinkable)

Port	Connects To
1	
2	
3	
4	
5	
6	
7	
8	
9	
10	
11	
12	
13	
14	
15	
16	
17	
18	
19	
20	
21	
22	
23	
24	

Figure 2-2. Setup and Cabling Chart

Rack Inventory Chart

Use this chart to record the components installed in a particular rack.

Date

Wiring Closet Number

Rack Number

Installer

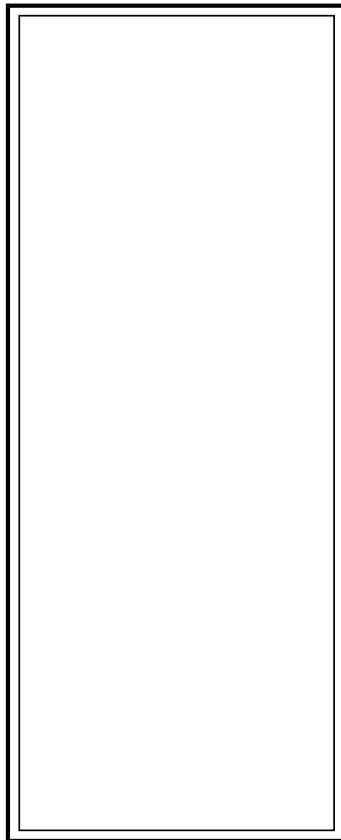

Example

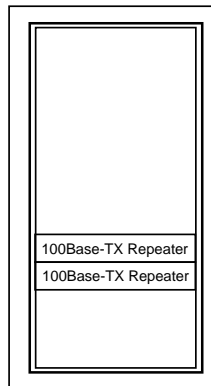

100Base-TX Repeater
100Base-TX Repeater

Figure 2-3. Rack Inventory Chart

Chapter 3

Installing the Repeater

This chapter explains how to mount the repeater, attach cables, and interconnect the repeater to a second repeater.

Mounting the Repeater

You can place the repeater on a level surface (table top or shelf, for example) or mount it in a standard EIA 19-inch rack.

Attaching the Rubber Feet

If you will place the repeater on a table top or shelf, attach the supplied adhesive-backed rubber feet as described in the following steps.

1. Turn the repeater over so that its bottom side faces up.
2. Remove the four rubber feet from their packaging.
3. Peel the protective paper backing off the rubber feet. Then position the feet in the recessed areas near the corners of the repeater and press the feet into place.
4. Turn the repeater to its upright position and place it on the mounting surface.

NOTE: Be sure you allow at least 2 inches (5 cm) on each side of the repeater for proper air flow.

Rack-Mounting the Repeater

The repeater occupies two slots in a standard, 19-inch rack. To mount the repeater in a rack, use the two side mounting brackets, eight smaller bracket screws, and four larger rack-mount screws.

To attach the brackets, follow these steps:

3-2 *Installing the Repeater*

1. Remove the two screws from the left and right side of the repeater. (These screws are extras and are not needed to install the mounting brackets.)
2. Position the bracket as shown in Figure 3-1, and secure it with the smaller bracket screws. Then attach the remaining bracket to the other side of the repeater.

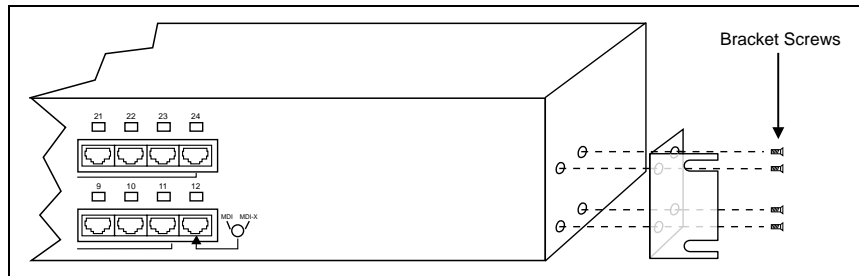

Figure 3-1. Attaching the Mounting Brackets

3. After you attach both mounting brackets, position the bracket slots over the desired holes on the rack (Figure 3-2). Then insert and tighten the supplied rack-mount screws.

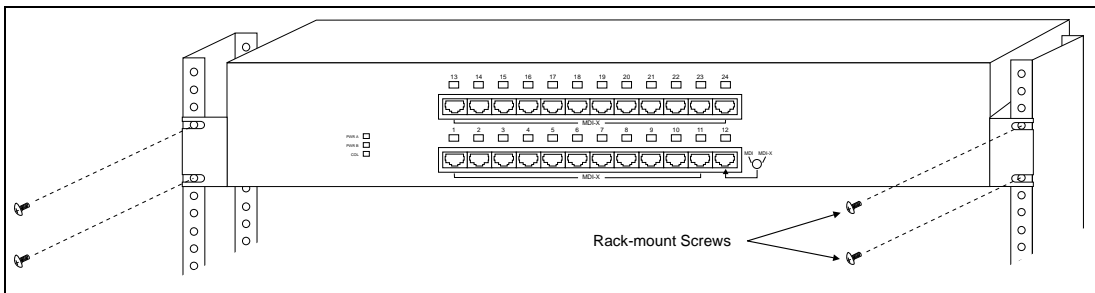

Figure 3-2. Positioning the Repeater in a Rack

Connecting Twisted-Pair Cable

Each RJ-45 port on the repeater can accept a standard 8-wire twisted-pair (UTP) cable that ends with an RJ-45 connector. These ports can support cable lengths up to 328 feet (100 meters).

To attach twisted-pair cable, plug one of the RJ-45 connectors into the selected port on the repeater. Connect the other RJ-45 connector into a 100Base-TX or 10Base-T workstation.

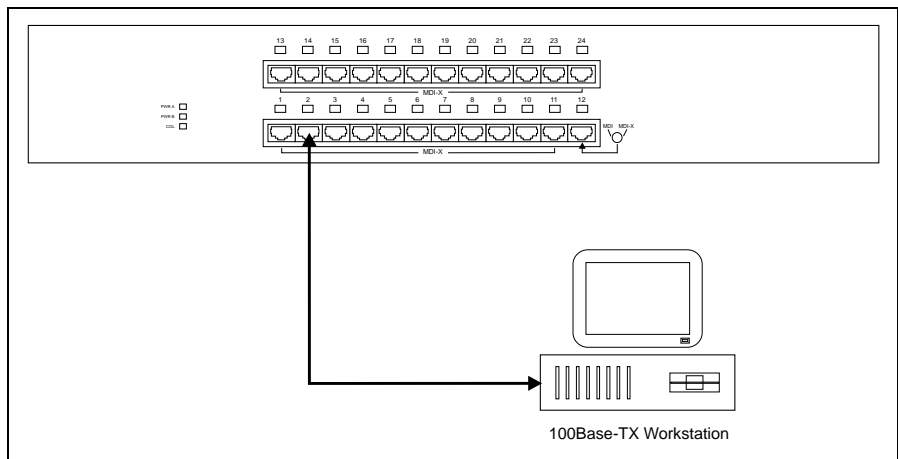

Figure 3-3. Connecting Twisted-Pair Cable

Setting the Uplink Switches

The uplink switches enable the 1st and 12th ports on the repeater to function as either standard IN RJ-45 ports or uplinkable OUT RJ-45 ports.

IN ports use an internal crossover of the receive and transmit lines, enabling the port to connect to a network interface card using standard 8-wire UTP cable. OUT ports let you interconnect the repeater and another repeater without the need for special crossover cables and allows the two repeaters to be on the same segment.

3-4 Installing the Repeater

The default setting for the uplink switches is **MDI-X** (Media Dependent Interface-Reversed, that is, a standard IN repeater port).

To convert Port 1 or Port 12 to an uplinkable OUT port, use a small, slotted screwdriver, or a similar tool, to set the switch to the **MDI** position (Figure 3-4).

NOTE: IEEE specifications allow only one 100 Mb/s uplink connection per collision domain. Therefore, you cannot uplink to two 100 Mb/s repeaters. However, you can use both uplink ports for 10 Mb/s uplink connections.

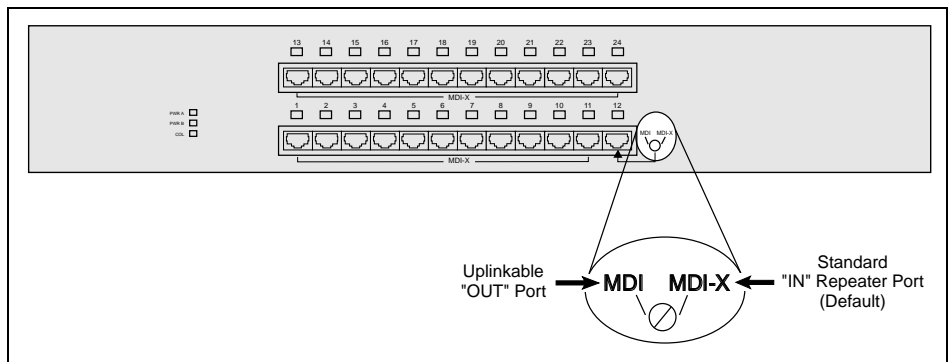

Figure 3-4. Uplink Switch (Default Setting)

Interconnecting Repeaters

You can interconnect two repeaters, providing up to 48 ports in the same collision domain (segment). You can also connect the repeater to a single-speed repeater (10 Mb/s or 100 Mb/s).

To connect the repeater to another repeater, set the appropriate uplink switch as described in “Setting the Uplink Switches” in this chapter and connect the repeaters as shown in Figure 3-5.

NOTE: At 100 Mb/s, the maximum cable distance between two repeaters is 5 meters (16.4 feet) while still allowing a maximum distance of 100 meters (328 feet) for repeater to workstation/server connections. At 10 Mb/s, the distance between two repeaters can be up to 100 meters.

To convert Port 1 or Port 12 to an uplinkable OUT port, use a small, slotted screwdriver, or a similar tool, to set the switch to the **MDI-X** position

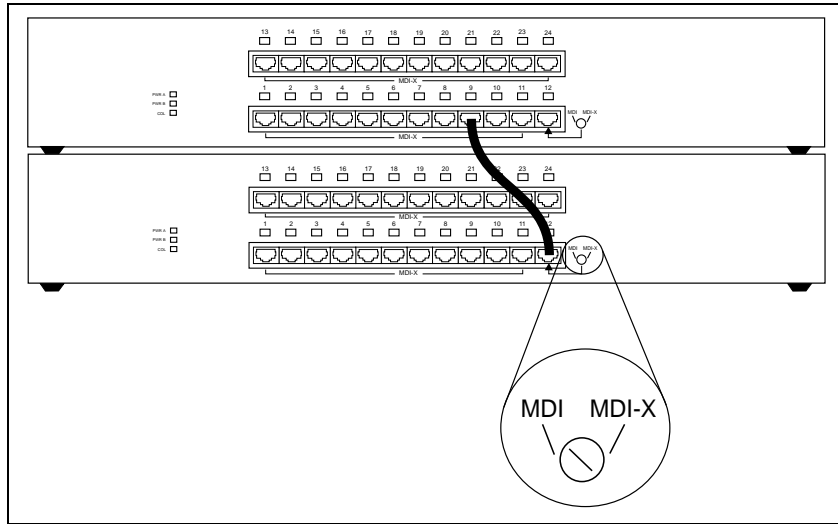

Figure 3-5. Interconnecting 100Base-TX Repeater

Connecting Power

Follow these steps to connect the repeater to power:

1. Plug the power cable into the power connector on the back of the repeater.

3-6 Installing the Repeater

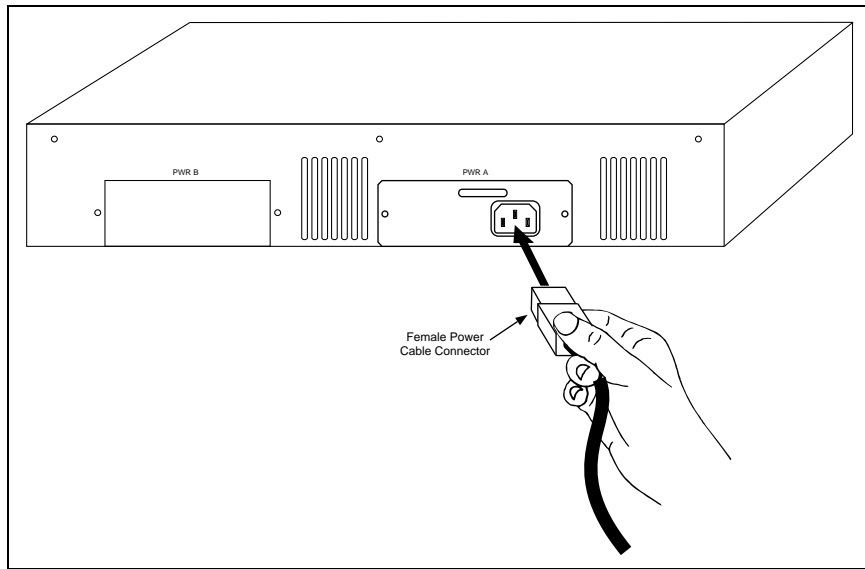

Figure 3-5. Connecting the Power Cable



WARNING: The repeater has no power switch. Connecting the repeater to the power source via the power cable's three-pronged plug powers up the repeater

2. Insert the three-pronged plug on the power cable into a non-switched, grounded power outlet on a wall, a power strip, or a grounded extension cord. When you plug the power cable into the power source, the **PWR A** LED lights steady green.

NOTE: The power outlet should be near the repeater and easily accessible.

Disconnecting Power

To power down the repeater, disconnect the power cord from the non-switched, grounded power outlet on the wall, power strip, or grounded extension cord. The power cord is not a TUV-tested disconnect. Therefore do not power down the repeater by disconnecting the power cord connector from the back of the repeater.

Replacing the Power Supply

The power supply's modular design makes the supply easy to replace. If power supply replacement is necessary, follow the instructions under “Installing a Redundant Power Supply Module” in the next section.

Installing a Redundant Power Supply Module

The repeater comes with a pre-installed, 90-watt power supply module (**PWR A**). You can install an optional redundant power supply module (**PWR B**) for backup power. Contact your authorized Compaq reseller for information about ordering an additional power supply module or a replacement.

Follow these steps to install a redundant power supply module.

NOTE: You can install the redundant power supply module while the main power supply module is powered on.

1. Remove the two screws from the **PWR B** cover plate and remove the plate. Be sure you keep the cover plate and screws in case you need them for future use.
2. Carefully insert the power supply module into the opening until its 10-pin connector engages with the internal power connector and the face of the module is flush with the repeater's back panel.
3. Secure the power supply by tightening its two spring screws.

3-8 Installing the Repeater

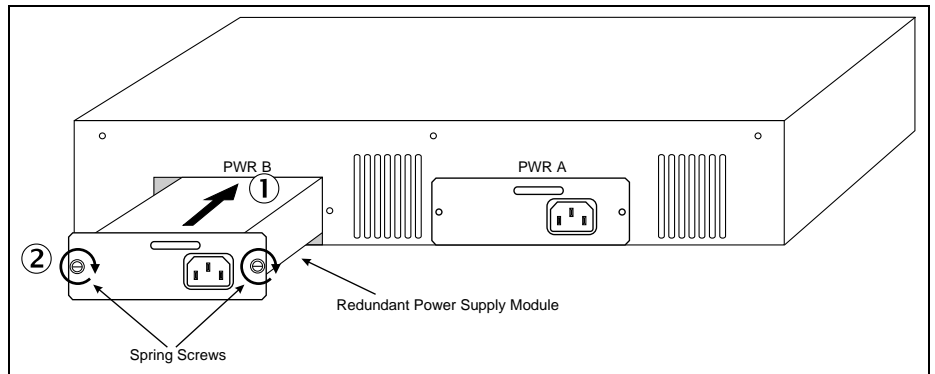

Figure 3-6. Installing a Redundant Power Module

4. Plug the power cord into the connector on the new power supply module.
5. Insert the power cord's three-pronged plug into a non-switched, grounded power outlet on a wall, a power strip, or a grounded extension cord. When you connect power, the **PWR B** LED indicator lights green, which means that the power supply module is installed and functioning correctly.

NOTE: If the power supply module does not have power or is not functioning correctly, the **PWR B** LED indicator lights yellow.

Appendix A

Specifications

Electrical Specifications

Ports and Connectors

- 24 shielded RJ-45 repeater ports for 100Base-TX
 - Port 12 — 100Base-TX uplink port with MDI/MDI-X option

LED Indicators

- Power (**PWR A** and **PWR B**) and Collision (**COL**)
- 24 RJ-45 port LEDs to indicate 100Base-TX status

Controls

- One two-position (MDI/MDI-X) uplink switch for uplink port

Power Requirements

- Voltage: 100 to 240 VAC
- Power: 1.5 to 0.75 Amps (1.5 Amps @ 100 VAC, 0.75 Amps @ 240 VAC)
- Frequency: 50 to 60 Hz

Power Consumption

- Maximum: 60 W

Power Cord (USA)

- 1.8 meters (6 feet), 10 Amps

Power Supply

- 90W (autosensing)
- +5 VDC at 14 Amps; +12 VDC at 2 Amps (no minimum load required)

Physical Specifications

Dimensions

- 3 x 16.95 x 14 inches, 7.6 x 43 x 33.6 cm (HxWxD)

Weight

- 9.9 pounds (4.5 kg)

Environmental Specifications

Operating Environment

- 32° to 122° F (0° to 50° C)
- 15% to 95% humidity at 50° C (non-condensing)
- 0 to 10,000 feet (0 to 3 km)

Storage Environment

- 32° to 151° F (0° to 66° C)
 - 15% to 95% humidity at 50° C (non-condensing)
 - 0 to 30,000 feet altitude (0 to 9 km)
-

Index

A

Air circulation requirements 2-2
Amps 2-1

C

Cable 3-5
Cable distance, maximum 3-4
Charts, planning 2-5
Class II support 1-1
Collision domain 3-4
Crossover cables 3-3

D

Default, uplink 3-3

E

Electrical requirements 2-1
Environmental requirements 2-1

H

Hz 2-1

I

IEEE 802.3u 1-1
IN port 1-7, 3-3

L

LEDs 1-1, 1-5, 1-6

M

MDI 3-4
MDI-X 3-3, 3-4
Media Dependent Interface-Reversed
3-3
Mounting brackets 3-2

O

OUT 1-7
OUT port 3-3

P

Package contents 1-2, 1-3
Part number 1-2
Planning charts 2-5
Power
 connecting 3-5
Power cord 1-2, 2-2
Power supply 1-1
 auto-sensing 1-1
 ordering 3-7
 redundant 3-7
 replacing 3-7

R

Repeater
 dimensions 2-2
 features 1-1
 front and back panels 1-4
 interconnecting 3-4
 mounting 3-1
 operational overview 1-4
 planning installation 2-1
 rack mounting 3-1
RJ-45 3-3
RJ-45 plug 2-3
RJ-45 port 3-3

RJ-45 ports 1-1, 1-4, 1-7

S

Segment 1-7, 3-3

T

Twisted pair

 crossover 2-4

 straight through 2-4

Twisted-pair wiring 2-2

U

Uplink port 1-1

Uplink switch 1-7, 3-3

UTP 1-7, 2-2, 3-3

V

VAC 2-1

W

Wire gauge 2-2

Wiring requirements 2-2

Wiring, new 2-3
