

akasa

HDD external enclosure

for data-storage mobility with LAN sharing



English

AKASA Company notices

The information contained in this document is subject to change without notice.

All rights reserved. Reproduction, adaptation, or translation of this material is prohibited without prior written permission of AKASA, except as allowed under copyright laws.

The only warranties for AKASA products and services are set forth in the express warranty statements accompanying such products and services. Nothing herein should be construed as constituting an additional warranty. AKASA shall not be liable for technical or editorial errors or omissions contained herein.

Acknowledgements

Microsoft, Windows, Windows NT and Windows XP are registered trademarks of Microsoft Corporation.

Adobe and Acrobat are trademarks of Adobe Systems Incorporation.

Netdisk, NDAS and XIMETA are trademarks of XIMETA Incorporation.

Copyright 2006 AKASA ASIA Corporation.

General Notice: Other product names used herein are for identification purposes only and may be trademarks of their respective owners. AKASA disclaims any and all rights in those marks.

Copyright Statement

It is a criminal offence, under applicable copyright laws, to make unauthorized copies of copyright-protected material, including computer programs, films, broadcasts and sound recordings. This equipment should not be used for such purposes.

Notice: The manufacture makes no warranty of any kind with regards to this material, including, but not limited to, the implied warranties of merchantability and fitness for a particular product. The manufacture shall not be liable for errors contained herein or for incidental consequential damages in connection with the furnishing, performance, or use of this material. Every effort has been made to ensure that the information in this manual is accurate. The manufacture is not responsible for printing or clerical errors. Mention of third party products is for information purposes only and constitutes neither an endorsement nor a recommendation. The manufacture assumes no responsibility with regards to the performance of these products. This document contains proprietary information, which is protected by copyright (see below). The information contained in this document is subject to change without notice.

FCC Compliance Statement

This device complies with Part 15 of the FCC Rules. Operation is subject to the following two conditions:

1. This device may not cause harmful interference, and
2. This device must accept any interference received, including interference that may cause undesired operation.

FCC Warning Statement

This equipment has been tested and found to comply with the limits for a Class B digital device, pursuant to Part 15 of the FCC Rules.

These limits are designed to provide reasonable protection against harmful interference in a residential installation. This equipment

generates, uses and can emit radio frequency energy and, if not installed or used in accordance with the instructions, may cause

interference to radio communications. However, television reception interference can be determined by turning the equipment off and on.

The user is encouraged to correct the interference by one or more of the following measures:

- Reorient or relocate the receiving antenna
- Increase the separation between the equipment and the receiver
- Connect the equipment into an outlet different from that to which the receiver is connected
- Consult the dealer or an experienced radio/TV technician for help.

CAUTION

Changes or modifications not expressly approved by the party responsible for compliance could void the user's authority to operate the equipment.



Introduction

Congratulations on your purchase of the INTEGRAL LAN 3.5" hard disk enclosure. This User Manual is intended to help you install the INTEGRAL LAN drive quickly and easily onto your Personal Computer or Ethernet Network and begin using it immediately. INTEGRAL LAN drives are the perfect solution to your network storage needs. Share documents, music, videos, and pictures with your family or coworkers through your network. Simply connect the drive to your network, install our easy to use software and you're up and running. Say goodbye to confusing network setups and configurations. With its Key Code security features, your data is kept private from unauthorized access.

The INTEGRAL LAN drive works in both network mode as well as a standalone USB mode. Take advantage of the ultra fast USB 2.0 transfer rates by connecting the INTEGRAL LAN drive directly to your PC's USB 2.0 port. With its portability, ease of use, high performance, and extra capacity, the INTEGRAL LAN drive has you covered.

Package Contents

- INTEGRAL LAN enclosure
- USER Manual
- Software & Driver CD
- Power Adapter
- USB & Ethernet Cables
- Footstand

System Requirement

- Pentium III or Athlon processor 800MHz (1.2 GHz or faster recommended)
- Windows XP/2000/ME/98SE
- 128MB of RAM (256MB recommended)
- One Available USB 1.1 Port for USB mode (USB 2.0 recommended)
- CD-ROM drive for installation
- 100Base-T full duplex switch for Network mode

Features

- Support 3.5" IDE HDD (PATA)
- Shared network direct attached storage (NDAS) for your home or office
- Easy setup and installation
- Sleek & portable design
- USB 2.0 (USB 1.1 backwards compatible)
- Key Code security protection
- Driver supports Windows: XP/2000 (Network Mode)
- XP/2000/ME/98SE (USB Mode)
- Data transfer rates of:
 - ! Network mode: 100Mbit/sec
 - ! USB mode: 480Mbit/second

Frequently Asked Questions

- For the latest **FAQ** look at the <http://www.akasa.co.uk/>

Harddisk Installation

1.

Open the back of the enclosure by undoing the securing screws and sliding the tray out of the aluminium housing.

NOTE: Disconnect the LED cable before completely sliding the HDD tray out .



2.

Write down the ID number and KEY before closing the enclosure. It is going to be needed in later stages of the network installation.



3.

Place the HDD in the tray aligning the correct IDE and power connectors. Then connect the IDE and power connectors to the HDD.

NOTE: Make sure the jumper setting of the HDD is set to master/single



4.

Position the HDD in the tray so that the mounting holes on the HDD line up with the tray mounting holes. Use the four screws supplied in the mounting kit to secure the HDD in the tray.



5.

Gently insert the tray into the enclosure aligning the guide rail with the grooves of the enclosure housing.



7.

Insert the tray completely into the housing and secure the enclosure face plate to the enclosure using the screws provided.



6.

Before fully inserting the tray, connect the HDD activity LED to the 4-pin connector leaving the pin to the right free. Make sure that the connector is inserted as shown on **1**.

NOTE: The integral logo on the front bezel serves two operational purposes: indicates power and hard drive activity (in USB mode).

8.

Connect the round end of the DC power cord to the back of the enclosure, making sure it is correctly aligned. Plug the AC cable into the power pack, and then connect the supplied adapter into an available AC socket.

NOTE: Please ensure that you are using the supplied power pack **only**.



Network Connection

Hardware installation

Connect INTEGRAL LAN drive to Network:

1. Connect one end of the included Ethernet cable to the Ethernet port on the INTEGRAL LAN enclosure and the other to a switch or router. (100 Base-T).
2. Make sure the power adaptor connector is firmly attached to the INTEGRAL LAN and to a power source.
3. Switch ON the INTEGRAL LAN.

CAUTION! Do not connect cable at the same time.

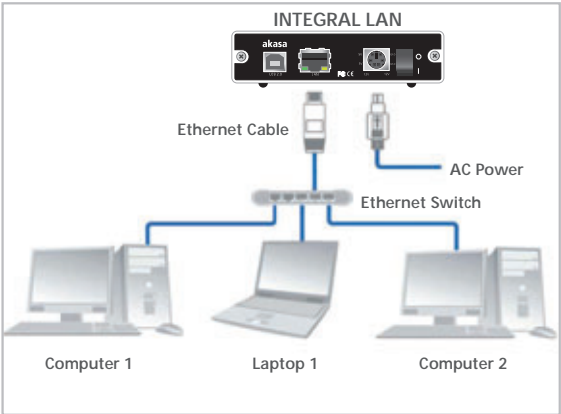

Ethernet Switch Example

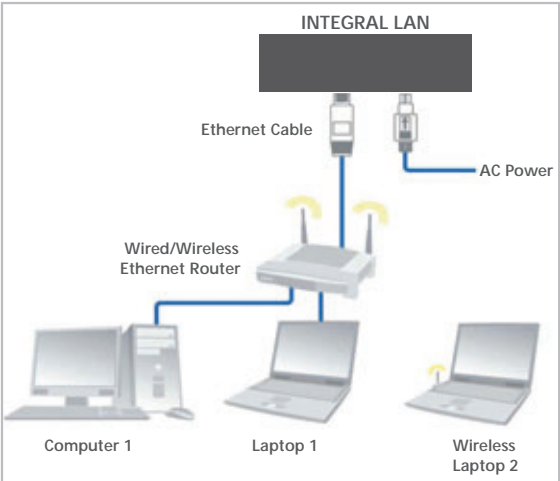

Ethernet Router Setup Example

Software installation

Installation of NDAS software is necessary to use your INTEGRAL LAN as a network device. Installation of NDAS software is simple and easy. Please insert the Installation CD into your optical drive. The CD automatically displays the language menu if Autorun is enabled in your computer.

NOTE: If Autorun is NOT enabled in you computer, browse the contents of the installation CD to locate the file autorun.bat from the main folder. Double-click the autorun.bat to run the CD.



akasa

1. Chose your menu language.

2. Select "win 2000/XP" and press "Run" when prompted

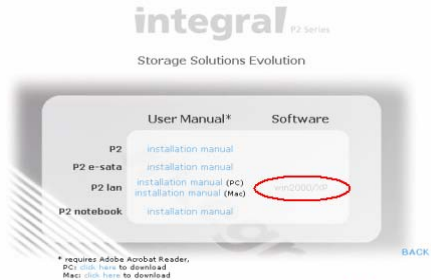

akasa

3. Select your installation language.

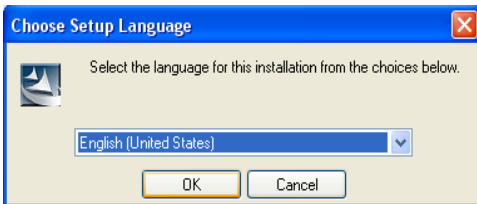

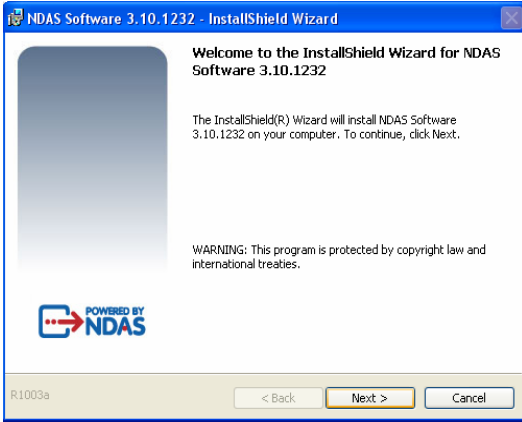

4. InstallShield Wizard will appear. Click the Next button to continue to next step.

5. Accept Licence Agreement if you agree to proceed to the installation, then click Next to continue the installation.

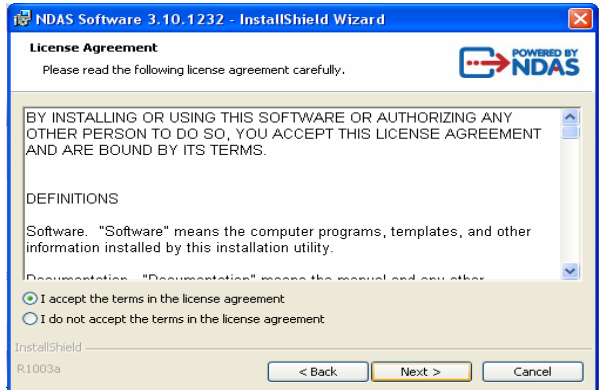

6. Click the Install button to install drivers

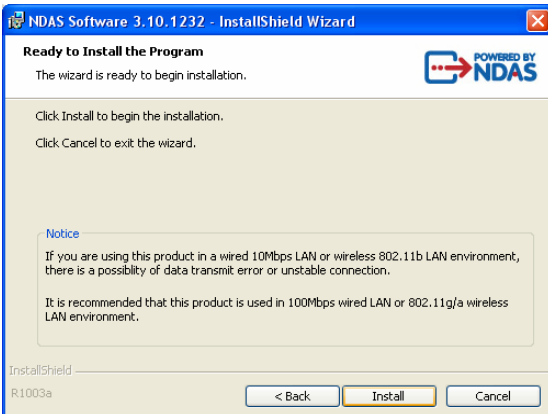



7. If the Windows Logo Testing message appears, click Yes or Continue Anyway to continue the installation.

8. After software installation is complete, click the Finish button.

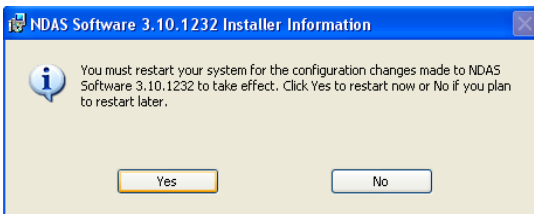

9. Click yes button if you are ready to restart the computer.
NOTE: The NDAS software will not work until you restart the system.

INTEGRAL LAN Registration and mounting

After installing the software, you need to register your INTEGRAL LAN if you are using new Integral drive in Network Mode. The steps below will guide you through the Registration Wizard which will help detect your new device.

NOTE: Connect the INTEGRAL LAN to network and turn it on before continuing.

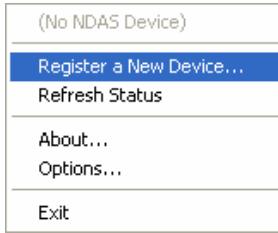

1.

Click on the NDAS Device Management Icon located on the system tray and select "Register a New Device". The "NDAS registration Wizard" will appear. Select NEXT to continue.

2.

Enter a chosen name for this device and press Next to continue.

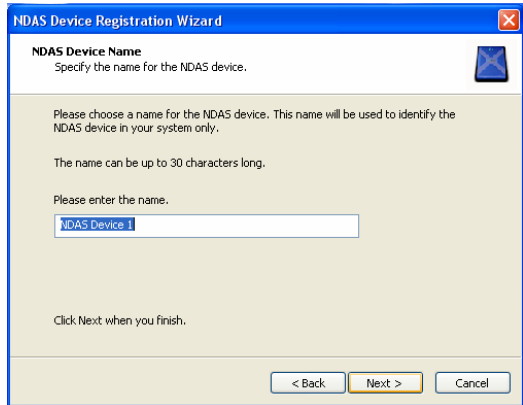

3.

Enter your integral LAN ID and KEY (see step 2 of Hard disk installation). Click next to continue. **NOTE:** A key is needed to write to this NDAS device. If the Write key is not provided, users of this system are restricted to Read Only from this device.

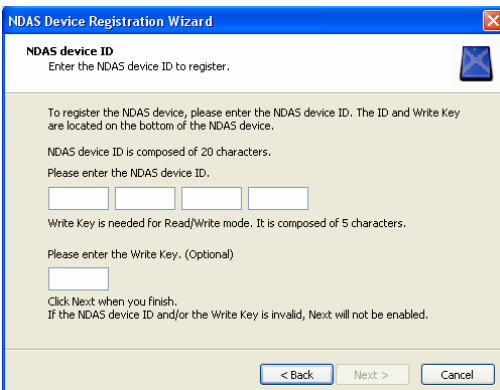

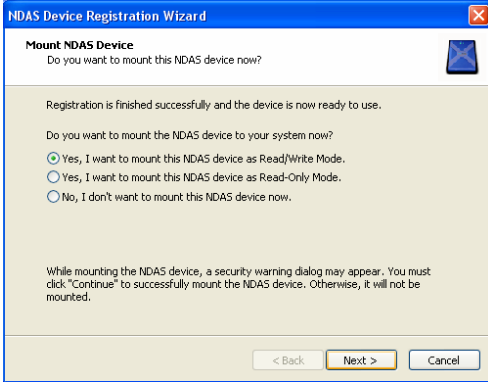

4. The Registration Wizard will check your NDAS device status and detect your new INTEGRAL LAN drive (if it has been connected and switched on). Choose how you want to mount the device and press Next.

- Read/Write mode mounts device to read and write.
- Read Only mode mounts device to read only.
- Don't Mount: device is left not connected.

NOTE: If you haven't entered the KEY the Write/Read mode is disabled.

5. After first time registration the "Found New Hardware Wizard" may appear. Select "No, not this time" and click Next to continue.

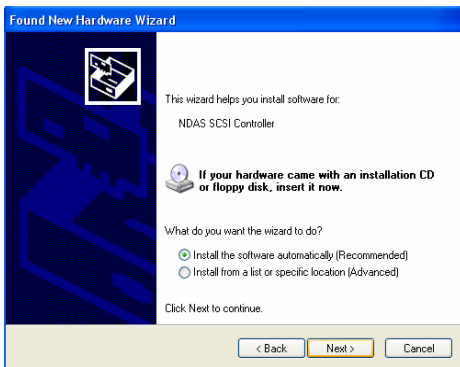
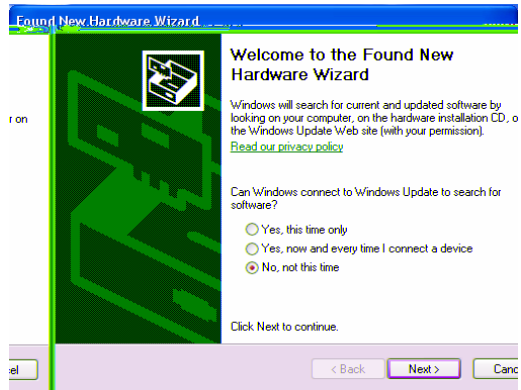

6. Select "Install the software automatically" and click Next to continue.

7. If the Windows Logo Testing message appears, click Yes or Continue Anyway to continue the installation.

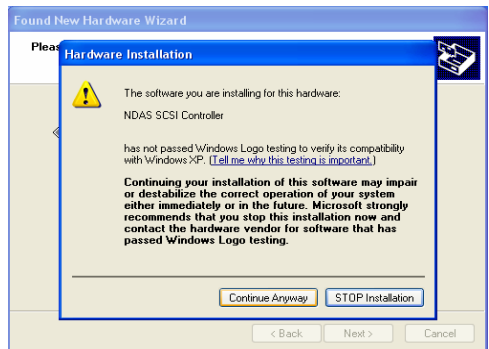



8. Windows will detect your new device and install the appropriate drivers. After installation press Finish.

9. Registering the INTEGRAL LAN device is complete when you click finish

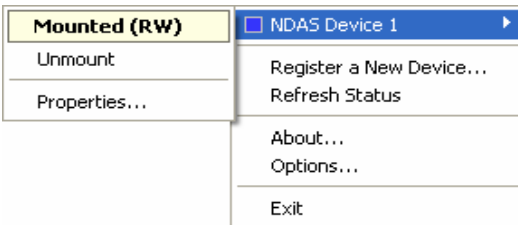

10. After you have registered your new device click the NDAS Device Management icon to see the registered and mounted NDAS device.

NOTE: If you cannot see your NDAS Device please click Refresh Status and check again. If your device is not formatted, please proceed to the Format Drive section.

11.

Your NDAS device will show up as a local drive once formatted in My Computer. Drive letter and NDAS device name may vary.

NOTE: When registering the INTEGRAL LAN for second time or registering another INTEGRAL LAN steps 5 to 8 do not apply.

Hard Disk Drives



Devices with Removable Storage



Using the INTEGRAL LAN in Network Mode

INTEGRAL LAN NDAS device can be used like a local drive on your PC. It allows you to:

- Drag and drop files to NDAS device.
- Copy and paste data to NDAS device.
- Create and delete folders.
- Share files and folders.
- Backup your data.

Sharing the INTEGRAL LAN on a Network

Once INTEGRAL LAN drive is connected to your network, it can be accessed from any computer on your network.

To share your INTEGRAL LAN, you need:

- All computers and INTEGRAL LAN drive to be on the same local network
- INTEGRAL LAN connected via Ethernet or Wireless Router
- All computers on the network using the NDAS device must have the INTEGRAL LAN disk driver version 3.1.x or later installed.
- NDAS device must be registered onto each computer.

Multiple-OS sharing:

- The INTEGRAL LAN can be shared by a mixture of ME/2000/XP and Mac computers
- Multiple computer can have READ ONLY access simultaneously
- WRITE ACCESS is assigned to one computer at a time and is passed from one computer to another

Multiple-Write sharing:

- Windows XP/2000 only network environment
- Multiple computer running XP or 2000 can have READ and WRITE access simultaneously

WARNING:

DO NOT perform disk operations (format, partition and chkdsk) when multiple PCs have the INTEGRAL LAN drive mounted.

The INTEGRAL LAN device can be formatted, partitioned, chkdsk, aggregated or mirrored when ONLY one PC is connected.

Click NDAS Device Management  to see the registered NDAS device.



Read/Write Mode













Read-Only Mode

NOTE: If you cannot see your NDAS Device, please click Refresh Status and check again.

NDAS Device Management

NDAS Device Status Modes

NDAS device provides users with six basic Modes. Below is a chart describing each of the NDAS device modes and the icons that correspond with each mode.

INTEGRAL LAN Icon Colour	Mode/Meaning	Bind Management Icon
 Green	Read-Only Mode <ul style="list-style-type: none"> Users can only read from INTEGRAL LAN 	
 Blue	Read/Write Mode <ul style="list-style-type: none"> Users can read and write to INTEGRAL LAN 	
 White	Connected Mode <ul style="list-style-type: none"> INTEGRAL LAN is currently disabled on your computer and is ready to be mounted (enable) 	
 Black	Disconnected Mode <ul style="list-style-type: none"> INTEGRAL LAN is registered but your system can not find it. Power Cord, Ethernet Cord or USB Cord maybe unplugged. Make sure any Antivirus /Firewall software or spyware is not interfering with the connection. 	
 Red	Deactivated Mode <ul style="list-style-type: none"> INTEGRAL LAN is registered but no longer communicates with your system. No attempts will be made to communicate with device. 	
Yellow (Bound)	Bound Non-Primary Mode <ul style="list-style-type: none"> Used for bound INTEGRAL LAN drives only. All of the bound INTEGRAL LAND drives are displayed as yellow except the primary device. 	

To see an INTEGRAL LAN status click on the NDAS Device Management icon located on the system tray. All registered NDAS device(s) will be displayed on the NDAS Device Management Menu.

WARNING :

Always unmount the INTEGRAL LAN enclosure on all PC's with access before switching it off. Alternatively you can shut down all the systems accessing the INTEGRAL LAN before switching it off.

NOTE: To change the status of the INTEGRAL LAN device you need to unmount it first.

NDAS Device Management Menu

Register a New Device	Registers an INTEGRAL LAN to your computer Updates status of your INTEGRAL LAN
Refresh Status	Displays NDAS software version information
About	Can customize INTEGRAL LAN management features and error messages/dialogs
Options	Exits INTEGRAL LAN Management
Mounted (RW)	INTEGRAL LAN mounted with read and write rights
Mounted (RO)	INTEGRAL LAN mounted with read only rights Enables users to change INTEGRAL LAN mode
Unmount	Displays properties of the INTEGRAL LAN
Properties	The INTEGRAL LAN is disconnected
Disconnected	Enables users to un-register INTEGRAL LAN device
Unregister	Displays properties of the INTEGRAL LAN
Properties	INTEGRAL LAN connected but not mounted
Connected	Mounts the INTEGRAL LAN with read only rights
Mount (Read-Only)	Mounts the INTEGRAL LAN with write/read rights
Mount (Read/Write)	There is no communication with INTEGRAL LAN
Deactivated	Activates INTEGRAL LAN into Connected mode
Activate	

Frequently Asked Questions

For the latest **FAQ** look at the <http://www.akasa.co.uk/>

NDAS Bind Management (Advance user only)

NOTE: ONLY available for the Windows 2000/XP network

If you have more than one INTEGRAL LAN you can connect them together in Bind Mode to provide immense storage capabilities. You can connect up to 8 enclosures together to form a single logical storage unit.

WARNING :

Binding and unbinding the drives may result in complete loss of data on all devices in that array!

Disclaimer:

In no event shall Akasa be liable for loss of data caused by any defect or usage of INTEGRAL LAN (including advance features)

There are three ways to bind: Aggregation, RAID0 and RAID1.

AGGREGATION

Allows any number between 2 and 8 of INTEGRAL LAN units to be recognized as a single large drive.

- Extremely useful when a larger storage device is needed.
- No fault tolerance. If one unit fails, all data is lost.

STRIPE (RAID 0)

Allows 2, 4, or 8 INTEGRAL LAN units to be recognized as a single large disk drive.

- Allows faster performance when writing.
- Extremely useful when a larger storage device is needed.
- No fault tolerance. If one unit fails, all data is lost.

MIRROR (RAID 1)

Allows 2, 4, 6 or 8 INTEGRAL LAN units to be mirrored at the same time.

- Fault tolerant. If one unit fails, data is retrieved from other units.
- Can also Mirror NDAS devices that have been aggregated.

The Bind Management Restrictions:

- Each INTEGRAL LAN must have Write Key entered during key registration
- It is not possible to Bind INTEGRAL LAN units that are already Bound
- INTEGRAL LAN units that are being Bound must be in Connected Mode (unmounted) on all PCs (including the PC performing the Bind)
- The INTEGRAL LAN unit being Bound must be formatted as NTFS file system
- Aggregation, RAID0 and RAID1 can only be performed in Windows XP and Windows 2000

The Bind Management Window

Bind: Used for Aggregation, RAID 0, and RAID 1

Unbind: Used to Unbind your Bound INTEGRAL LAN

Tools: There are two different functions in Tools:

- **Add Mirror** is used to Mirror the first INTEGRAL LAN to the second INTEGRAL LAN.
- **Resynchronize** is used to recover the data on Mirrored INTEGRAL LAN.

Refresh: Used to refresh status of the INTEGRAL LAN

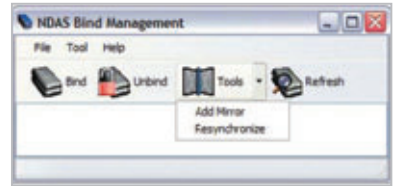

Binding two or more INTEGRAL LAN

1. Before INTEGRAL LAN can be Bound, they must be in Connected Mode (white icon in the NDAS Device Management) on all PCs accessing the NDAS device. All of the NDAS devices must have registered Write Key entered.
2. To start Bind Management software you need to go to Start/All programs/NDAS Software/NDAS Bind Management.
3. Click the Bind button.
4. Choose a binding type and number of disks to be bound.
 - Aggregation can bind any number of units between 2 and 8.
 - RAID0 can bind 2, 4 or 8 units.
 - RAID1 can bind 2, 4, 6 or 8 units.
5. Move the chosen NDAS devices from the left window to the right window.
6. Two warning messages will appear:
 - Once NDAS devices are bound, all of the data will be lost. Click Yes to continue.
 - The new bound NDAS devices must be mounted and formatted before it can be used. Click OK.
7. Your NDAS Devices should now be bound. Go to the NDAS Device Management and Mount the Bound NDAS devices.
8. Found New Hardware Wizard may appear. Click Next and proceed in finishing the wizard.
9. Before Bound NDAS device can be used, it must be formatted. Please go to **"HOW TO PARTITION THE EXTERNAL HARD DISK"**.



Unbinding INTEGRAL LAN's

1. Go to NDAS Device Management and select a Bound NDAS device you want to Unbind.
2. Unmount the NDAS Device by clicking on Unmount.

Note: If the bound NDAS device is in use, a warning message will appear. Make sure that no programs are using the NDAS Device and try again.
3. After you have unmounted the NDAS Devices, go to NDAS Bind Management.
4. From the NDAS Bind Management select the Bound NDAS device you have just unmounted. Click the Unbind button.
5. Unbind window will appear. Make sure these NDAS devices are ones that needs to be unbound and click Yes.
6. Two warning messages will appear:
 - Once NDAS devices are unbound, all of your data will be lost. Click Yes to continue.
 - The new unbound NDAS devices must be mounted and formatted before it can be used. Click OK.
7. Now you can go back into the NDAS Device Management and Mount each of unbound NDAS devices. Before using the NDAS devices, please format each of the unbound device. Please refer to Formatting INTEGRAL LAN.

Bind Tools:

Add Mirror

The Add Mirror function is used when you have a NDAS device with data on it and then want to copy it to another NDAS device that does not have any data. This provides a reliable backup of the data if the first drive fails. The second NDAS device must be of equal or greater capacity to use this function.

1. Go to Start > Programs > NDAS Software > NDAS Bind
2. Select a single NDAS device.

Note: A NDAS device must be in a Connected Mode and have the Write Key.
3. Click Tool button and select Add Mirror.
4. From the list, select a NDAS device you want to mirror the first NDAS device to. Click OK.
5. A warning message will appear. Click Yes.
6. Add Mirror window will appear. Click Start to start synchronizing.

Recover Tool

The Recover Mirror function is used to restore a failed drive.

1. If an Emergency Mode message appears, it indicates an error has occurred on a Mirrored NDAS Devices.
2. Go to NDAS Device Management and unmount the Mirrored NDAS Devices.

Note: NDAS device must be in a Connected Mode and have the Write Key.

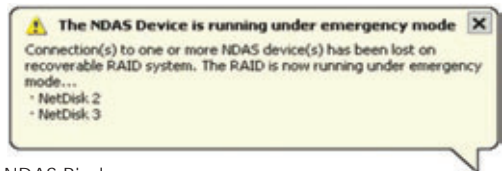

3. Go to Start > Programs > NDAS Software > NDAS Bind
4. Select on the Mirrored NDAS devices.
5. Click Tool button and select Recover Mirror.
6. Recover Mirror will appear. Click Start button.

USB Mode Connection

Hardware installation

1. Connect your INTEGRAL LAN to the computer using the supplied USB cable
2. Connect the supplied power pack to any available AC socket and your INTEGRAL LAN.
3. Switch on the power and your enclosure is ready to use.

Note: In order to reach USB 2.0 speed, you must have a motherboard or host adapter card that has USB 2.0 support. This device will auto sense the speed of your USB port and adjust between USB 1.0 and USB 2.0 speed.

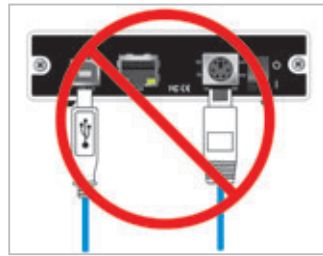
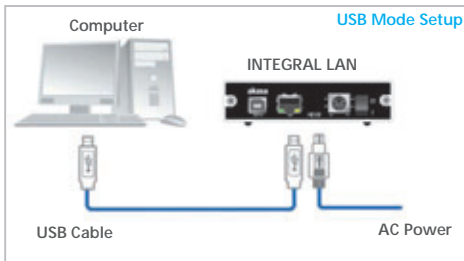

CAUTION! Do not connect USB cable and Ethernet cable at the same time.

Software installation

Windows Me / 2000 / XP

NOTE: enclosed CD driver disk is not required for the installation

1. When the USB External Drive is used for the first time your PC system will detect a USB2.0 Storage Device and automatically install the drivers for [\[USB Mass Storage Device\]](#) from the installed system files.

2. When the PC system finishes installing the USB mass storage device driver, double click on [\[My Computer\]](#). A drive Disk is added after few seconds, this is the INTEGRAL LAN drive.



NOTE:

This INTEGRAL LAN drive is supported by Mass Storage Device within WIN Me/2000/XP system directly. You do not need to install any drivers. If the external hard disk is a new disk drive which has not been partitioned, please refer to the [Partition the External Hard Disk chapter](#) to prepare your USB2.0 external disk.

Using the INTEGRAL LAN Device

After the first installation, you can connect or disconnect the INTEGRAL LAN device without powering off the computer, please follow the steps when you want to do the above actions.

Disconnecting the INTEGRAL LAN

WARNING!!

Do not unplug the USB2.0 cable nor the power cable from the Integral Drive unit or break the communications with the USB HUB while copying files to or from the device or when files or applications stored on the USB2.0 External Drive are being accessed. DOING THIS MAY RESULT IN LOSS OF DATA!

1.

Double-click on the [Unplug arrow icon or Eject Hardware] icon in the system tray. Dialog box appears as on the right.



2.

Highlight the [USB Mass Storage Device] in the dialog box, click on [Stop], choose the USB2.0 External Drive that you want to disconnect, then click on [Stop] again on next screen.

3.

Wait for few seconds, the system prompts "You may safely remove this device". Unplug the USB cable from the USB port of the computer.



How to partition the INTEGRAL LAN disk

WARNING!!

Before you partition your hard disk, please be aware that this will destroy all your existing data on the drive, so make sure you have a backup! This step is usually only required the first time you install a factory new hard drive or if you want to change the existing format.

Note: If you use the following steps in Windows 2000/XP then the hard drive inside the INTEGRAL LAN will be formatted in NTFS. In order to use the INTEGRAL LAN in mixed environment (Windows and Mac) the disk need to be formatted in FAT32 and a third party format utility should be used to do it.

Partition/Formatting can be done in Network or USB mode. It is recommended to do it in Network mode.

1. Right click **My Computer** and select **Manage**. A window appears as on the right.
2. Click on **Disk Management** and all connected disk drives will be listed in the right part of the window. Find the Hard Disk that you added. On the right of Disk# is the status of the partitions of this disk drive, you can create a new or delete an existing partition by right clicking on this area.
3. Right-click on the right area of Disk#, click on **Create Partition....** The **Create partition wizard** will appear.
4. Following the wizard instructions to partition and format your HDD.

