



The Wireless Connectivity Expert

48511 Warm Springs Blvd., Suite 206, Fremont, CA 94539, USA

Tel: +1-510 490-8024 Fax: +1-510-623-7268

Web: <http://www.actisys.com>, E-mail: irda-info@actisys.com



ACT-IR320L

LONG DISTANCE INFRARED ADAPTER

USER'S MANUAL



November 6, 2006

Version 1.0

**© Copyright 2000-2006 ACTiSYS Corporation,
All Rights Reserved**

TABLE OF CONTENT

REVISION HISTORY	3
1. OVERVIEW	4
2. FEATURES	4
3. APPLICATION DESCRIPTION	5
4. DTE-DB9M CONNECTOR DESCRIPTION	6
5. CHARACTERISTICS AND SPECIFICATIONS	6
6. LED BEHAVIOR	6

REVISION HISTORY

Revision History		
Revision	Date	Comment
0.1	02/28/2002	Draft Preliminary Design Specification for internal review.
1.0	11/06/2006	Added LED behavior chapter & changed connection distance

ACTiSYS reserves the right to make changes without further notice to any products herein to improve reliability, function or design. ACTiSYS does not assume any liability arising out of the application or use of any product or circuit described herein.

1. OVERVIEW

The ACT-IR320L is a long distance infrared adapter that enables the host system with long distance infrared communication capabilities. The host system may be an industrial controller, a data collector, a medical instrument, or any other device. The interface between ACT-IR320L and the host is the traditional asynchronous serial data port (RS232C). Figure 1.1 shows the system block diagram.

Figure 1.1 System Block

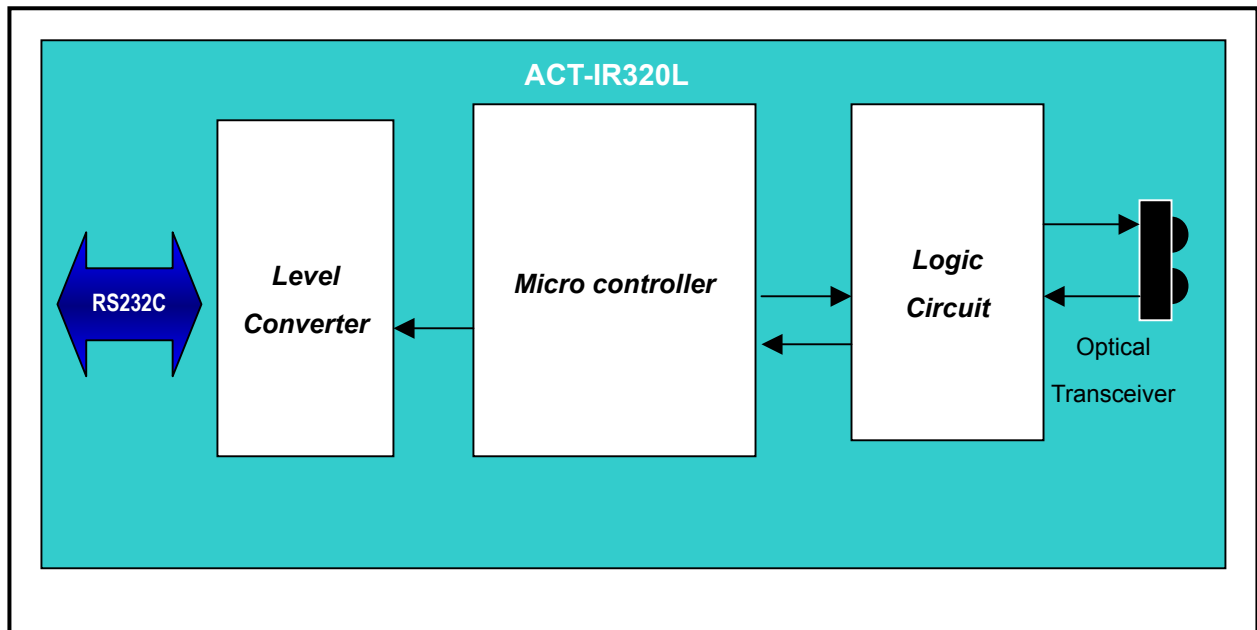

2. FEATURES

- Long distance transmitting / receiving adapter by using 455 KHz ASK-IR technology.
- Supports maximum **30 meters** transmitting / receiving distance.
- Supports 9.6 kbps, 19.2 kbps and 38.4 kbps baud rate.
- Instantly converts RS232 Port to IR, without special IrDA protocol SW and uses existing application SW.
- True cable-to-IR replacement using ASK-IR technology.
- No buffer in circuit, no delay caused.
- Need to be used in pairs.

3. APPLICATION DESCRIPTION

ACT-IR320L uses 455 KHz ASK-IR technology to support long distance transmitting / receiving. ASK-IR is a technology that based on sub-carrier and it is not compatible to IrDA. Therefore, it should be **used in pairs**.

Once ACT-IR320L is connected to serial port of host device, it enters into *ready mode*. The LED is **on**. Two ways can make IR320L to enter into *active mode*. One is the host device sends some data to it by passing RxD pin. Another is that IR320L receives ASK sub-carrier from outside and passes those data to TxD pin. When IR320L is in *active mode*, the LED **blinks**.

ACT-IR320L *detects RxD* pin's level and turns the ASK sub-carrier *on and off* when it is sending data. Thus no need to care about baud rate setting. It's only limited by the frequency of ASK modulation. The baud rate supports up to 38.4 kbps.

Generally, there are two ways to connect to a serial port. One is 3-wires (Flow Control free), while another is 9-wires (Flow Control enabled). Based on ACT-IR320L no buffer in circuit, it is a 3-wires operating dongle. It doesn't have to enable flow control mechanism. It means that it doesn't detect the DSR and CTS pins from host device and always pull DTR and RTS pins to high. Application program itself should take care of flow control.

The radiant intensity of ACT-IR320L relates to angle between two dongles that face to face. The angle of half intensity is +/- 10°. It will get more effective performance by adjusting angle.

4. DTE-DB9M CONNECTOR DESCRIPTION

ACT-IR320L is a DTE adapter, like serial port on PC. It can be connected to any DCE device directly. If you want to connect this adapter to a Notebook or Desktop computer, the DB9F-to-DB9F converter is needed. The converter plays like a null-modem, redirecting serial port signals from DTE to another DTE.

Pin No.	Name	Descriptions	I/O
1	CD	Data Carrier Detect	I
2	RXD	Receiver Data	I
3	TXD	Transmitter Data	O
4	DTR	Data Terminal Ready	O
5	GND	Signal Ground	GND
6	DSR	Data Set Ready	I
7	RTS	Request to Send	O
8	CTS	Clear to Send	I
9	RI	Ring Indicator	I

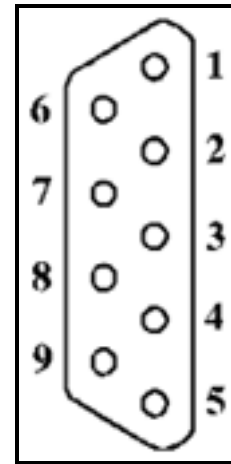

Front View

5. CHARACTERISTICS AND SPECIFICATIONS

Parameter	Min.	Typical	Max.	Units
DC supply voltage	5.0	7.5	12	V
Supply voltage, VSS		0		V
Operating temperature range	0		60	°C
DC current (Ready mode)		2		mA
DC current (Active mode)		200	300	mA
RS232 signal threshold level	+/-3	+/-12	+/-25	V

6. LED BEHAVIOR

Activities Status	LED Behavior
COM port closed & disconnected	LED off
Ready (COM port opened & connected) mode	LED on
Active (Data transfer) mode	LED blinks once per bit