

SONY[®]

ANALOG AUDIO DISTRIBUTION BOARD

BKPF-L753A

MAINTENANCE MANUAL

1st Edition (Revised 1)

Serial No. 10001 and Higher

⚠ 警告

このマニュアルは、サービス専用です。

お客様が、このマニュアルに記載された設置や保守、点検、修理などを行うと感電や火災、人身事故につながる可能性があります。

危険をさけるため、サービストレーニングを受けた技術者のみご使用ください。

⚠ WARNING

This manual is intended for qualified service personnel only.

To reduce the risk of electric shock, fire or injury, do not perform any servicing other than that contained in the operating instructions unless you are qualified to do so. Refer all servicing to qualified service personnel.

⚠ WARNUNG

Die Anleitung ist nur für qualifiziertes Fachpersonal bestimmt.

Alle Wartungsarbeiten dürfen nur von qualifiziertem Fachpersonal ausgeführt werden. Um die Gefahr eines elektrischen Schlages, Feuergefahr und Verletzungen zu vermeiden, sind bei Wartungsarbeiten strikt die Angaben in der Anleitung zu befolgen. Andere als die angegeben Wartungsarbeiten dürfen nur von Personen ausgeführt werden, die eine spezielle Befähigung dazu besitzen.

⚠ AVERTISSEMENT

Ce manuel est destiné uniquement aux personnes compétentes en charge de l'entretien. Afin de réduire les risques de décharge électrique, d'incendie ou de blessure n'effectuer que les réparations indiquées dans le mode d'emploi à moins d'être qualifié pour en effectuer d'autres. Pour toute réparation faire appel à une personne compétente uniquement.

Table of Contents

Manual Structure

Purpose of this manual	3 (E)
Contents	3 (E)
Related manuals	3 (E)

1. Service Overview

1-1. Notes on Repair Parts	1-1 (E)
1-2. IC Link Replacement	1-1 (E)
1-3. Shield Case (S/N10001 through S/N17325)	1-1 (E)
1-4. Name and Function of Switch/Indicator/etc.	1-2 (E)
1-5. Unleaded Solder	1-3 (E)

2. Electrical Alignment

2-1. Electrical Alignment Overview	2-1 (E)
2-1-1. Required Equipment and Tools	2-1 (E)
2-1-2. Connection	2-1 (E)
2-2. Preparation of Adjustment	2-2 (E)
2-3. Input/Output Gain Adjustment	2-2 (E)
2-4. CMRR (Common Mode Rejection Ratio) Adjustment	2-3 (E)
2-5. Input/Output Gain Adjustment for Customer Setting	2-3 (E)

3. Spare Parts

ADA-55	3-1
CN-1855/1856	3-4
DD-36	3-4

4. Semiconductor Pin Assignments

5. Block Diagram

Overall	5-1
---------------	-----

6. Schematic Diagrams

ADA-55	6-2
CN-1855/1856	6-3
DD-36	6-4

7. Board Layouts

ADA-55	7-1
DD-36	7-2

Manual Structure

Purpose of this manual

This manual is the maintenance manual of Analog Audio Distribution Board BKPF-L753A.

This manual is intended for use by trained system and service engineers, and describes the information for periodic maintenance and detailed service.

Contents

This manual is organized by following sections.

Section 1 Service Overview

This section explains the notes on repair parts and IC link replacement.

Section 2 Electrical Alignment

This section explains the adjustment after replacing part.

Section 3 Spare Parts

This section describes the spare parts.

Section 4 Semiconductor Pin Assignments

This section describes the pin assignments of semiconductor.

Section 5 Block Diagram

This section describes the overall block diagram.

Section 6 Schematic Diagrams

This section describes the schematic diagrams of the ADA-55, DD-36 and CN-1855/1856 boards.

Section 7 Board Layouts

This section describes the board layouts for the ADA-55 and DD-36 boards.

Related manuals

The following manual is prepared for this unit.

- **Installation Manual (Supplied with BKPF-L753A)**

This manual describes the information on BKPF-L753A installing.

Section 1

Service Overview

1-1. Notes on Repair Parts

1. Safety Related Components Warning

WARNING

Components marked \triangle are critical to safe operation. Therefore, specified parts should be used in the case of replacement.

2. Standardization of Parts

Some repair parts supplied by Sony differ from those used for the unit. These are because of parts commonality and improvement.

Parts list has the present standardized repair parts.

3. Stock of Parts

Parts marked with “o” at SP (Supply code) column of the spare parts list may not be stocked. Therefore, the delivery date will be delayed.

4. Units Representation

The following represented units are changed or omitted in writing.

	Units	Representation
Capacitance	μ F	uF
Inductance	μ H	uH
Resistance	Ω	Abbreviation

Note

For the replacement of the ADA-55 board, please buy BKPF-L753A because ADA-55 mounted circuit board is not prepared for spare parts.

1-2. IC Link Replacement

WARNING

An IC link is critical parts to safe operation. Replace this component with Sony parts whose part numbers appear in this manual published by Sony. If not, this may cause a fire or electric shock. Be sure to use the specified component in this manual.

The IC link is mounted on the ADA-55 board. Be sure to replace with the specified IC link as shown below after removing the foreign substances that may cause the shorts.

ADA-55 Board

Ref No. (Address)	Description	Part No.
PS1 (K-3)	IC link 2 A	\triangle 1-533-282-21

1-3. Shield Case (S/N10001 through S/N17325)

The shield case is a component to shield the DD-36 board. Before checking the DD-36 board, unsolder and remove this shield case.

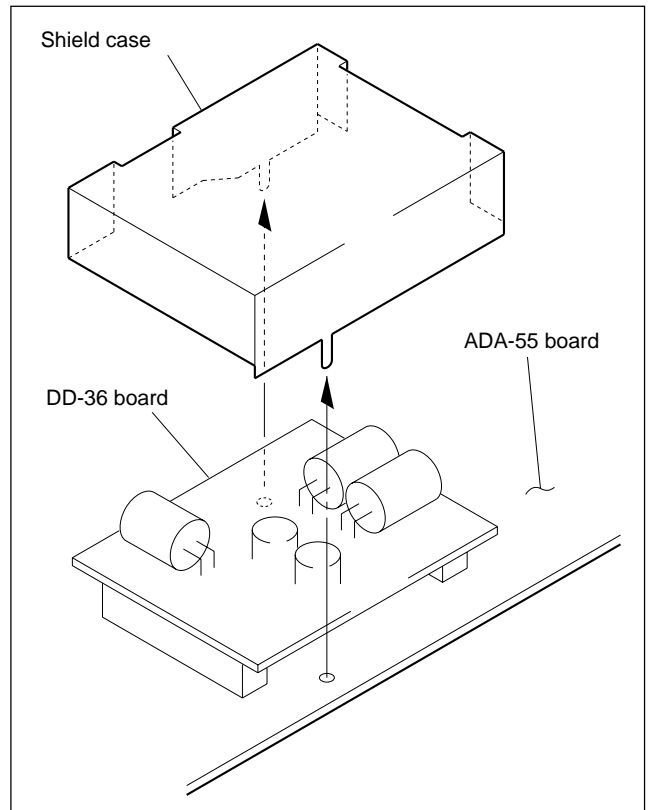

1-4. Name and Function of Switch/Indicator/etc.

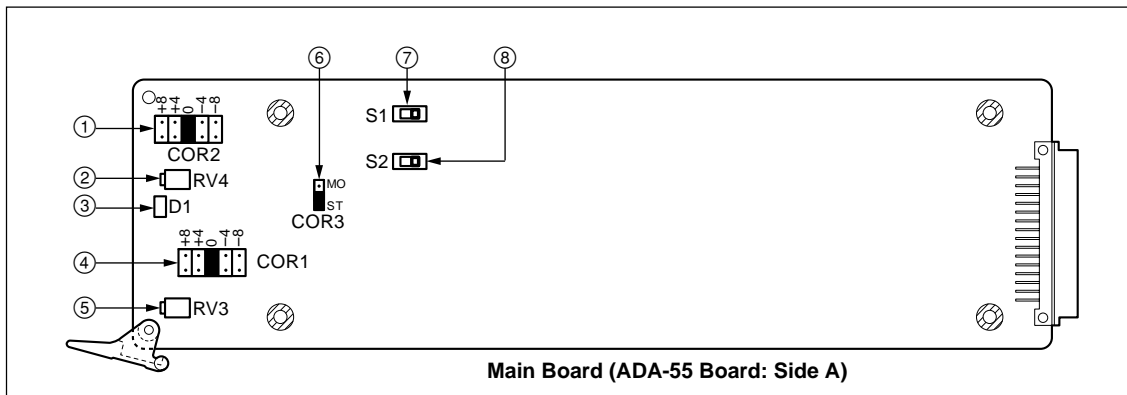

Switches/shorting plugs (Factory default settings are indicated by a ■ mark)

No.	Ref. No.	Name	Function
⑦	S1	AUDIO 1 600 Ω	Selects the input impedance of the signal input to the AUDIO 1 connector. OFF: 20 kΩ ■ ON: 600 Ω
⑧	S2	AUDIO 2 600 Ω	Selects the input impedance of the signal input to the AUDIO 2 connector. OFF: 20 kΩ ■ ON: 600 Ω
④	COR1	AUDIO 2 GAIN	Selects an input/output gain of the signal input to the AUDIO 2 connector. (Valid only when COR3 is set to ST.) +8 dB +4 dB ■ 0 dB -4 dB -8 dB
①	COR2	AUDIO 1 GAIN	Selects an input/output gain of the signal input to the AUDIO 1 connector. +8 dB +4 dB ■ 0 dB -4 dB -8 dB
⑥	COR3	MONAURAL/STEREO	Selects monaural or stereo mode of the analog audio signal input/output. MO (Monaural): The signal input to the AUDIO 1 connector is distributed to eight outputs ■ ST (Stereo): The each signal input to the AUDIO 1 and AUDIO 2 connectors is distributed to four outputs

Indicator

No.	Ref. No.	Name	Color	Function
③	D1	POWER	Green/red	Green: A power supply of ±12 V is normal Red: A power supply of ±12 V is abnormal

Gain adjusting VR

No.	Ref. No.	Name	Function
⑤	RV3	AUDIO 2 FINE VR	Adjusts the gain of the signal input to AUDIO 2 connector within the ±2 dB range.
②	RV4	AUDIO 1 FINE VR	Adjusts the gain of the signal input to AUDIO 1 connector within the ±2 dB range.

Note

At the factory-out, the gain adjusting VRs were adjusted to 0 dB. (the standard level +4 dBm)

1-5. Unleaded Solder

Boards requiring use of unleaded solder are printed with a lead free mark (LF) indicating the solder contains no lead. (Caution: Some printed circuit boards may not come printed with the lead free mark due to their particular size.)

 : LEAD FREE MARK

Notes

- Be sure to use the unleaded solder for the printed circuit board printed with the lead free mark.
- The unleaded solder melts at a temperature about 40 °C higher than the ordinary solder, therefore, it is recommended to use the soldering iron having a temperature regulator.
- The ordinary soldering iron can be used but the iron tip has to be applied to the solder joint for a slightly longer time. The printed pattern (copper foil) may peel away if the heated tip is applied for too long, so be careful.

Section 2

Electrical Alignment

2-1. Electrical Alignment Overview

2-1-1. Required Equipment and Tools

Use the equipment listed below or the equivalent.

Item	Model	Remarks
Extension board	EX-731 (Part No. A-8322-598-A)	
Audio signal generator *	Tektronix SG505 (Option-02)	
Audio level meter *	—	
Interface unit	Sony PFV-L1 or PFV-L10	
Adjustment screwdriver	—	Insulation type
Resister (600 Ω , within 1 %)		with lead

※: Use the equipment after calibration has been completed.

2-1-2. Connection

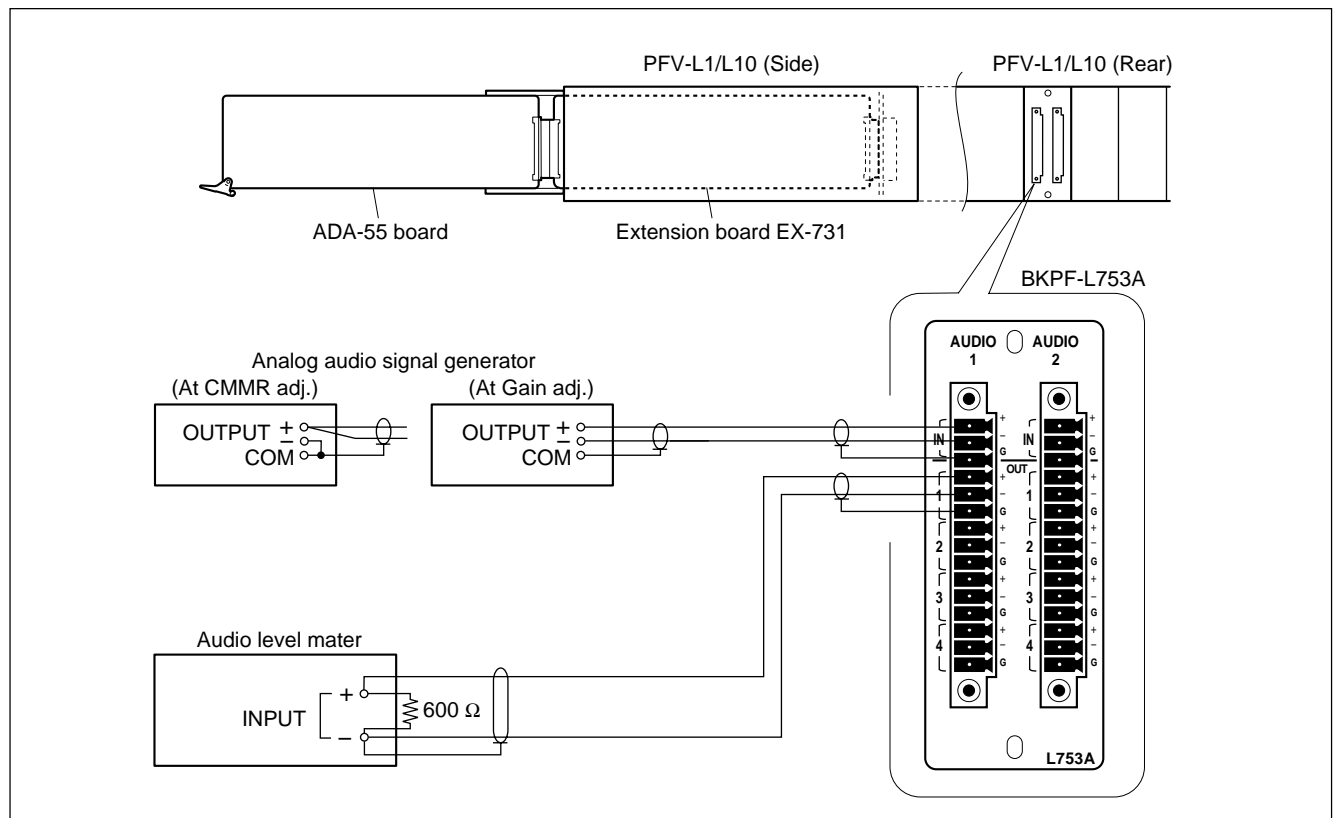

2-2. Preparation of Adjustment

1. Extend the ADA-55 board with a extension board.
2. Write the customer settings of the shorting plugs (COR1, COR2, and COR3) and switches (S1, and S2) on the ADA-55 board down in following table.
3. Set their shorting plugs and switches as follows:

Ref. No. (Address)	Setting at adj.	Customer setting
COR1 (A-3)	0 dB	_____
COR2 (A-1)	0 dB	_____
COR3 (C-2)	ST (STEREO)	_____
S1 (D-1)	ON (600 Ω)	_____
S2 (D-2)	ON (600 Ω)	_____

4. Turn on the power of equipment (the signal generator, audio level meter, and interface unit PFV-L1 or PFV-L10), and warm up them for about ten minutes.
5. Attach the 600 Ω resistor for termination to the audio level meter.

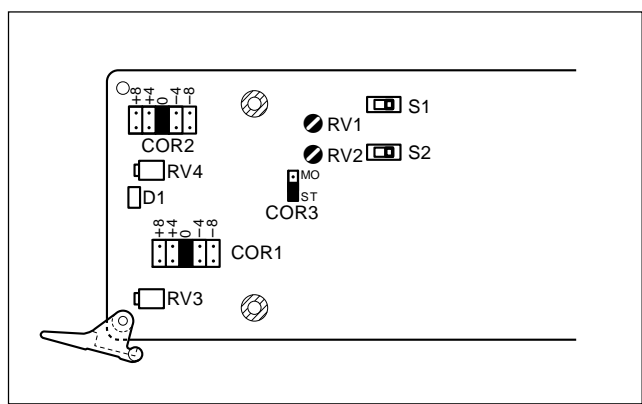

ADA-55 Board (Side A)

2-3. Input/Output Gain Adjustment

Measuring equipment: Audio level meter

1. Set the output of the generator to +4.0 dBm, 1 kHz.
(0 dBm ≅ 0.775 Vrms)

CH1 adjustment

2. Connect the audio signal generator to the input of CH1 connector.
3. Connect the audio level meter to one output of CH1 connector.
4. Check that COR2 (A-1) is set to 0 dB.
If not, set it to 0 dB.
5. Adjust the CH1 output level on the audio level meter.
Adjustment point: ●RV4/ADA-55 (A-2)
Specification: 4.0 ± 0.1 dBm (at 600 Ω load)

CH2 adjustment

6. Connect the audio signal generator to the input of CH2 connector.
7. Connect the audio level meter to one output of CH2 connector.
8. Check that COR1 (A-3) is set to 0 dB.
If not, set it to 0 dB.
9. Adjust the CH2 output level on the audio level meter.
Adjustment point: ●RV3/ADA-55 (A-3)
Specification: 4.0 ± 0.1 dBm (at 600 Ω load)

2-4. CMRR (Common Mode Rejection Ratio) Adjustment

Measuring equipment: Audio level meter

1. Set the output of the generator to +15.0 dBm, 60 Hz.

CH2 adjustment

2. Connect the audio signal generator to the input of CH2 connector.
3. Connect the audio level meter to one output of CH2 connector.
4. Adjust the CH2 output level on the audio level meter.
 Adjustment point: RV2/ADA-55 (C-2)
 Specification: Less than -65 dBm (at 600Ω load)

CH1 adjustment

5. Connect the audio signal generator to the input of CH1 connector.
6. Connect the audio level meter to one output of CH1 connector.
7. Adjust the CH1 output level on the audio level meter.
 Adjustment point: RV1/ADA-55 (C-1)
 Specification: Less than -65 dBm (at 600Ω load)

2-5. Input/Output Gain Adjustment for Customer Setting

Note

When the audio gain (COR1 or COR2) is not 0 dB, be sure to perform this adjustment.

Measuring equipment: Audio level meter

1. Reset the shorting plugs (COR1 and COR2) on the ADA-55 board to customer settings.

CH1 adjustment

2. Set the output of the generator to the customer setting of COR1 as follows:

COR1/COR2 customer setting	Output signal
-8 dB	+12.0 dBm, 1 kHz
-4 dB	+8.0 dBm, 1 kHz
(0 dB)	(+4.0 dBm, 1 kHz)
+4 dB	0.0 dBm, 1 kHz
+8 dB	-4.0 dBm, 1 kHz
	(0 dBm \doteq 0.775 Vrms)

3. Connect the audio signal generator to the input of CH1 connector.
4. Connect the audio level meter to one output of CH1 connector.
5. Adjust the CH1 output level on the audio level meter.
 Adjustment point: RV4/ADA-55 (A-2)
 Specification: 4.0 ± 0.1 dBm (at 600Ω load)

CH2 adjustment

6. Set the output of the generator to the customer setting of COR2. (Refer to table in step 2.)
7. Connect the audio signal generator to the input of CH2 connector.
8. Connect the audio level meter to one output of CH2 connector.
9. Adjust the CH2 output level on the audio level meter.
 Adjustment point: RV3/ADA-55 (A-3)
 Specification: 4.0 ± 0.1 dBm (at 600Ω load)
10. After turning off the power, reset the shorting plug (COR3) and switches (S1 and S2) on the ADA-55 board to the customer settings.

Section 3 Spare Parts

ADA-55 BOARD

(ADA-55 BOARD)

*1:[Board No. suffix -11,12]
*2:[Board No. suffix -14]

Ref. No. or Q'ty	Part No.	SP Description
1pc	3-179-084-01	s LEVER (R), PC BOARD
or	3-179-085-01	s LEVER (L), PC BOARD
1pc	3-194-617-01	o HEAT SINK
1pc	3-203-115-01	o CASE, SHIELD (for DD1)
2pcs	7-685-547-14	s SCREW +BTP 3x10
8pcs	7-682-948-01	s SCREW +PSW 3x8
C1	1-164-346-11	s CERAMIC, CHIP 1.0uF 16V (2012)
C2	1-126-391-11	s ELECT, CHIP 47uF 20% 6.3V
C3	1-164-346-11	s CERAMIC, CHIP 1.0uF 16V (2012)
C4	1-126-396-11	s ELECT, CHIP 47uF 20% 16V
C5	1-126-396-11	s ELECT, CHIP 47uF 20% 16V
C6	1-126-396-11	s ELECT, CHIP 47uF 20% 16V
C7	1-126-396-11	s ELECT, CHIP 47uF 20% 16V
C8	1-163-113-00	s CERAMIC, CHIP 68pF 5% 50V (2012)
C9	1-126-396-11	s ELECT, CHIP 47uF 20% 16V
C10	1-126-396-11	s ELECT, CHIP 47uF 20% 16V
C11	1-163-113-00	s CERAMIC, CHIP 68pF 5% 50V (2012)
C12	1-164-346-11	s CERAMIC, CHIP 1.0uF 16V (2012)
C13	1-164-346-11	s CERAMIC, CHIP 1.0uF 16V (2012)
C14	1-164-346-11	s CERAMIC, CHIP 1.0uF 16V (2012)
C15	1-164-346-11	s CERAMIC, CHIP 1.0uF 16V (2012)
C16	*2 1-117-681-11	s CAPACITOR, ELECT 100MF/16V
	*1 1-128-397-21	s ELECT 100uF 20% 16V
C17	*2 1-117-681-11	s CAPACITOR, ELECT 100MF/16V
	*1 1-128-397-21	s ELECT 100uF 20% 16V
C18	*2 1-117-681-11	s CAPACITOR, ELECT 100MF/16V
	*1 1-128-397-21	s ELECT 100uF 20% 16V
C19	*2 1-117-681-11	s CAPACITOR, ELECT 100MF/16V
	*1 1-128-397-21	s ELECT 100uF 20% 16V
C20	1-164-346-11	s CERAMIC, CHIP 1.0uF 16V (2012)
C21	1-164-346-11	s CERAMIC, CHIP 1.0uF 16V (2012)
C22	1-164-346-11	s CERAMIC, CHIP 1.0uF 16V (2012)
C23	1-164-346-11	s CERAMIC, CHIP 1.0uF 16V (2012)
C24	1-163-224-11	s CERAMIC, CHIP 7pF 50V (2012)
C25	1-164-346-11	s CERAMIC, CHIP 1.0uF 16V (2012)
C26	1-164-346-11	s CERAMIC, CHIP 1.0uF 16V (2012)
C27	1-126-396-11	s ELECT, CHIP 47uF 20% 16V
C28	1-126-396-11	s ELECT, CHIP 47uF 20% 16V
C29	1-163-235-11	s CERAMIC, CHIP 22pF 5% 50V (2012)
C30	1-126-396-11	s ELECT, CHIP 47uF 20% 16V
C31	1-126-396-11	s ELECT, CHIP 47uF 20% 16V
C32	1-164-346-11	s CERAMIC, CHIP 1.0uF 16V (2012)
C33	1-164-346-11	s CERAMIC, CHIP 1.0uF 16V (2012)
C34	1-126-396-11	s ELECT, CHIP 47uF 20% 16V
C35	1-126-396-11	s ELECT, CHIP 47uF 20% 16V
C36	1-163-224-11	s CERAMIC, CHIP 7pF 50V (2012)
C37	1-164-346-11	s CERAMIC, CHIP 1.0uF 16V (2012)
C38	1-164-346-11	s CERAMIC, CHIP 1.0uF 16V (2012)
C39	1-126-396-11	s ELECT, CHIP 47uF 20% 16V
C40	1-126-396-11	s ELECT, CHIP 47uF 20% 16V
C41	1-163-235-11	s CERAMIC, CHIP 22pF 5% 50V (2012)
C42	1-107-781-11	s ELECT, NONPOLAR 47uF 20% 16V
C43	1-107-781-11	s ELECT, NONPOLAR 47uF 20% 16V

Ref. No. or Q'ty	Part No.	SP Description
C44	1-107-781-11	s ELECT, NONPOLAR 47uF 20% 16V
C45	1-107-781-11	s ELECT, NONPOLAR 47uF 20% 16V
C46	1-163-227-11	s CERAMIC, CHIP 10pF 5% 50V (2012)
C47	1-163-224-11	s CERAMIC, CHIP 7pF 50V (2012)
C48	1-164-346-11	s CERAMIC, CHIP 1.0uF 16V (2012)
C49	1-164-346-11	s CERAMIC, CHIP 1.0uF 16V (2012)
C50	1-163-227-11	s CERAMIC, CHIP 10pF 5% 50V (2012)
C51	1-163-224-11	s CERAMIC, CHIP 7pF 50V (2012)
C52	1-164-346-11	s CERAMIC, CHIP 1.0uF 16V (2012)
C53	1-164-346-11	s CERAMIC, CHIP 1.0uF 16V (2012)
C54	1-163-227-11	s CERAMIC, CHIP 10pF 5% 50V (2012)
C55	1-163-224-11	s CERAMIC, CHIP 7pF 50V (2012)
C56	1-164-346-11	s CERAMIC, CHIP 1.0uF 16V (2012)
C57	1-164-346-11	s CERAMIC, CHIP 1.0uF 16V (2012)
C58	1-163-227-11	s CERAMIC, CHIP 10pF 5% 50V (2012)
C59	1-163-224-11	s CERAMIC, CHIP 7pF 50V (2012)
C60	1-164-346-11	s CERAMIC, CHIP 1.0uF 16V (2012)
C61	1-164-346-11	s CERAMIC, CHIP 1.0uF 16V (2012)
C62	1-126-396-11	s ELECT, CHIP 47uF 20% 16V
C63	1-126-396-11	s ELECT, CHIP 47uF 20% 16V
C64	1-126-396-11	s ELECT, CHIP 47uF 20% 16V
C65	1-126-396-11	s ELECT, CHIP 47uF 20% 16V
C66	1-126-396-11	s ELECT, CHIP 47uF 20% 16V
C67	1-126-396-11	s ELECT, CHIP 47uF 20% 16V
C68	1-126-396-11	s ELECT, CHIP 47uF 20% 16V
C69	1-126-396-11	s ELECT, CHIP 47uF 20% 16V
C70	1-163-235-11	s CERAMIC, CHIP 22pF 5% 50V (2012)
C71	1-163-235-11	s CERAMIC, CHIP 22pF 5% 50V (2012)
C72	1-163-235-11	s CERAMIC, CHIP 22pF 5% 50V (2012)
C73	1-163-235-11	s CERAMIC, CHIP 22pF 5% 50V (2012)
C74	1-107-420-11	s ELECT, CHIP 47uF 20% 35V
C75	1-107-420-11	s ELECT, CHIP 47uF 20% 35V
C76	1-107-420-11	s ELECT, CHIP 47uF 20% 35V
C77	1-107-420-11	s ELECT, CHIP 47uF 20% 35V
C78	1-163-241-11	s CERAMIC, CHIP 39pF 5% 50V (2012)
C79	1-163-241-11	s CERAMIC, CHIP 39pF 5% 50V (2012)
C80	1-163-241-11	s CERAMIC, CHIP 39pF 5% 50V (2012)
C81	1-163-241-11	s CERAMIC, CHIP 39pF 5% 50V (2012)
C82	1-163-241-11	s CERAMIC, CHIP 39pF 5% 50V (2012)
C83	1-163-241-11	s CERAMIC, CHIP 39pF 5% 50V (2012)
C84	1-163-241-11	s CERAMIC, CHIP 39pF 5% 50V (2012)
C85	1-163-241-11	s CERAMIC, CHIP 39pF 5% 50V (2012)
C86	*2 1-117-681-11	s CAPACITOR, ELECT 100MF/16V
	*1 1-128-397-21	s ELECT 100uF 20% 16V
C87	*2 1-117-681-11	s CAPACITOR, ELECT 100MF/16V
	*1 1-128-397-21	s ELECT 100uF 20% 16V
C88	*2 1-117-681-11	s CAPACITOR, ELECT 100MF/16V
	*1 1-128-397-21	s ELECT 100uF 20% 16V
C89	*2 1-117-681-11	s CAPACITOR, ELECT 100MF/16V
	*1 1-128-397-21	s ELECT 100uF 20% 16V
C90	1-164-346-11	s CERAMIC, CHIP 1.0uF 16V (2012)
C91	1-164-346-11	s CERAMIC, CHIP 1.0uF 16V (2012)
C92	1-164-346-11	s CERAMIC, CHIP 1.0uF 16V (2012)
C93	1-164-346-11	s CERAMIC, CHIP 1.0uF 16V (2012)
C94	1-164-346-11	s CERAMIC, CHIP 1.0uF 16V (2012)
C95	1-164-346-11	s CERAMIC, CHIP 1.0uF 16V (2012)
C96	1-164-346-11	s CERAMIC, CHIP 1.0uF 16V (2012)

(ADA-55 BOARD)

Ref. No. or Q'ty	Part No.	SP	Description
C97	1-164-346-11	s	CERAMIC, CHIP 1.0uF 16V (2012)
C98	1-164-346-11	s	CERAMIC, CHIP 1.0uF 16V (2012) (S/N 10001 to 11870)
CN101	1-506-746-11	s	CONNECTOR, DIN 48P, MALE
COP1	1-562-579-11	s	PLUG, SHORTING
COP2	1-562-579-11	s	PLUG, SHORTING
COP3	1-562-579-11	s	PLUG, SHORTING
COR1	1-691-506-11	s	CONNECTOR, 10P, MALE
COR2	1-691-506-11	s	CONNECTOR, 10P, MALE
COR3	1-564-948-11	o	CONNECTOR, 3P, MALE
D1	8-719-027-84	s	LED CL-155UR/G-D, RED/GRN
DD36	*2 1-475-611-11	s	CONVERTER UNIT, DC-DC
IC1	8-759-700-96	s	IC NJM5534M
IC2	8-759-700-96	s	IC NJM5534M
IC3	8-759-700-96	s	IC NJM5534M
IC4	8-759-700-96	s	IC NJM5534M
IC5	8-759-700-96	s	IC NJM5534M
IC6	8-759-700-96	s	IC NJM5534M
IC7	8-759-700-96	s	IC NJM5534M
IC8	8-759-700-96	s	IC NJM5534M
IC9	8-759-700-96	s	IC NJM5534M
IC10	8-759-700-96	s	IC NJM5534M
IC11	8-759-990-63	s	IC PCF8574AT (S/N 10001 to 11870)
L1	1-424-643-11	s	COIL, CHOKe 10uH
L2	1-424-643-11	s	COIL, CHOKe 10uH
L3	1-424-643-11	s	COIL, CHOKe 10uH
PS1	Δ 1-533-282-21	s	LINK, IC, CHIP 2A
Q1	8-729-120-28	s	TRANSISTOR 2SC1623-L5L6
Q2	8-729-120-28	s	TRANSISTOR 2SC1623-L5L6
Q3	8-729-216-22	s	TRANSISTOR 2SA1162-G
Q4	8-729-120-28	s	TRANSISTOR 2SC1623-L5L6
Q5	8-729-120-28	s	TRANSISTOR 2SC1623-L5L6
Q6	8-729-216-22	s	TRANSISTOR 2SA1162-G
Q7	8-729-120-28	s	TRANSISTOR 2SC1623-L5L6
Q8	8-729-216-22	s	TRANSISTOR 2SA1162-G
Q9	8-729-120-28	s	TRANSISTOR 2SC1623-L5L6
Q10	8-729-216-22	s	TRANSISTOR 2SA1162-G
Q11	8-729-120-28	s	TRANSISTOR 2SC1623-L5L6
Q12	8-729-216-22	s	TRANSISTOR 2SA1162-G
Q13	8-729-120-28	s	TRANSISTOR 2SC1623-L5L6
Q14	8-729-216-22	s	TRANSISTOR 2SA1162-G
Q15	8-729-120-28	s	TRANSISTOR 2SC1623-L5L6
Q16	8-729-216-22	s	TRANSISTOR 2SA1162-G
Q17	8-729-120-28	s	TRANSISTOR 2SC1623-L5L6
Q18	8-729-216-22	s	TRANSISTOR 2SA1162-G
Q19	8-729-120-28	s	TRANSISTOR 2SC1623-L5L6
Q20	8-729-216-22	s	TRANSISTOR 2SA1162-G
Q21	8-729-120-28	s	TRANSISTOR 2SC1623-L5L6
Q22	8-729-216-22	s	TRANSISTOR 2SA1162-G
Q23	8-729-120-28	s	TRANSISTOR 2SC1623-L5L6
Q24	8-729-216-22	s	TRANSISTOR 2SA1162-G
Q25	8-729-120-28	s	TRANSISTOR 2SC1623-L5L6
Q26	8-729-216-22	s	TRANSISTOR 2SA1162-G
Q27	8-729-120-28	s	TRANSISTOR 2SC1623-L5L6

(ADA-55 BOARD)

Ref. No. or Q'ty	Part No.	SP	Description
Q28	8-729-216-22	s	TRANSISTOR 2SA1162-G
Q29	8-729-207-89	s	TRANSISTOR 2SA1358-Y
Q30	8-729-207-82	s	TRANSISTOR 2SC3421-Y
Q31	8-729-207-89	s	TRANSISTOR 2SA1358-Y
Q32	8-729-207-82	s	TRANSISTOR 2SC3421-Y
Q33	8-729-207-89	s	TRANSISTOR 2SA1358-Y
Q34	8-729-207-82	s	TRANSISTOR 2SC3421-Y
Q35	8-729-207-89	s	TRANSISTOR 2SA1358-Y
Q36	8-729-207-82	s	TRANSISTOR 2SC3421-Y
Q37	8-729-425-05	s	TRANSISTOR UN2221
R1	1-216-639-11	s	METAL, CHIP 330 0.5% 1/10W (2012)
R2	1-216-623-11	s	METAL, CHIP 68 0.5% 1/10W (2012)
R3	1-216-639-11	s	METAL, CHIP 330 0.5% 1/10W (2012)
R4	1-216-623-11	s	METAL, CHIP 68 0.5% 1/10W (2012)
R5	1-216-687-11	s	METAL, CHIP 33K 0.5% 1/10W (2012)
R6	1-216-687-11	s	METAL, CHIP 33K 0.5% 1/10W (2012)
R7	1-216-679-11	s	METAL, CHIP 15K 0.5% 1/10W (2012)
R8	1-216-635-11	s	METAL, CHIP 220 0.5% 1/10W (2012)
R9	1-216-651-11	s	METAL, CHIP 1.0K 0.5% 1/10W (2012)
R10	1-216-635-11	s	METAL, CHIP 220 0.5% 1/10W (2012)
R11	1-216-678-11	s	METAL, CHIP 13K 0.5% 1/10W (2012)
R12	1-216-679-11	s	METAL, CHIP 15K 0.5% 1/10W (2012)
R13	1-216-675-11	s	METAL, CHIP 10K 0.5% 1/10W (2012)
R14	1-216-675-11	s	METAL, CHIP 10K 0.5% 1/10W (2012)
R15	1-218-367-11	s	METAL, CHIP 10K 0.1% 1/16W (2012)
R16	1-218-367-11	s	METAL, CHIP 10K 0.1% 1/16W (2012)
R17	1-218-367-11	s	METAL, CHIP 10K 0.1% 1/16W (2012)
R18	1-218-367-11	s	METAL, CHIP 10K 0.1% 1/16W (2012)
R19	1-218-366-11	s	METAL, CHIP 3.3K 0.1% 1/10W (2012)
R20	1-218-366-11	s	METAL, CHIP 3.3K 0.1% 1/10W (2012)
R21	1-216-659-11	s	METAL, CHIP 2.2K 0.5% 1/10W (2012)
R22	1-218-366-11	s	METAL, CHIP 3.3K 0.1% 1/10W (2012)
R23	1-218-366-11	s	METAL, CHIP 3.3K 0.1% 1/10W (2012)
R24	1-216-659-11	s	METAL, CHIP 2.2K 0.5% 1/10W (2012)
R25	1-216-651-11	s	METAL, CHIP 1.0K 0.5% 1/10W (2012)
R26	1-216-619-11	s	METAL, CHIP 47 0.5% 1/10W (2012)
R27	1-216-619-11	s	METAL, CHIP 47 0.5% 1/10W (2012)
R28	1-216-619-11	s	METAL, CHIP 47 0.5% 1/10W (2012)
R29	1-216-619-11	s	METAL, CHIP 47 0.5% 1/10W (2012)
R30	1-216-659-11	s	METAL, CHIP 2.2K 0.5% 1/10W (2012)
R31	1-216-659-11	s	METAL, CHIP 2.2K 0.5% 1/10W (2012)
R32	1-216-603-11	s	METAL, CHIP 10 0.5% 1/10W (2012)
R33	1-216-603-11	s	METAL, CHIP 10 0.5% 1/10W (2012)
R34	1-216-669-11	s	METAL, CHIP 5.6K 0.5% 1/10W (2012)
R35	1-216-669-11	s	METAL, CHIP 5.6K 0.5% 1/10W (2012)
R36	1-216-686-11	s	METAL, CHIP 30K 0.5% 1/10W (2012)
R37	1-216-682-11	s	METAL, CHIP 20K 0.5% 1/10W (2012)
R38	1-216-677-11	s	METAL, CHIP 12K 0.5% 1/10W (2012)
R39	1-216-668-11	s	METAL, CHIP 5.1K 0.5% 1/10W (2012)
R40	1-216-668-11	s	METAL, CHIP 5.1K 0.5% 1/10W (2012)
R41	1-216-663-11	s	METAL, CHIP 3.3K 0.5% 1/10W (2012)
R42	1-216-655-11	s	METAL, CHIP 1.5K 0.5% 1/10W (2012)
R43	1-216-686-11	s	METAL, CHIP 30K 0.5% 1/10W (2012)
R44	1-216-682-11	s	METAL, CHIP 20K 0.5% 1/10W (2012)
R45	1-216-677-11	s	METAL, CHIP 12K 0.5% 1/10W (2012)
R46	1-216-668-11	s	METAL, CHIP 5.1K 0.5% 1/10W (2012)
R47	1-216-668-11	s	METAL, CHIP 5.1K 0.5% 1/10W (2012)
R48	1-216-611-11	s	METAL, CHIP 22 0.5% 1/10W (2012)
R49	1-216-611-11	s	METAL, CHIP 22 0.5% 1/10W (2012)
R50	1-216-662-11	s	METAL, CHIP 3.0K 0.5% 1/10W (2012)

(ADA-55 BOARD)

Ref. No. or Q'ty	Part No.	SP	Description
R51	1-216-662-11	s	METAL, CHIP 3.0K 0.5% 1/10W (2012)
R52	1-216-611-11	s	METAL, CHIP 22 0.5% 1/10W (2012)
R53	1-216-611-11	s	METAL, CHIP 22 0.5% 1/10W (2012)
R54	1-216-663-11	s	METAL, CHIP 3.3K 0.5% 1/10W (2012)
R55	1-216-667-11	s	METAL, CHIP 4.7K 0.5% 1/10W (2012)
R56	1-216-611-11	s	METAL, CHIP 22 0.5% 1/10W (2012)
R57	1-216-611-11	s	METAL, CHIP 22 0.5% 1/10W (2012)
R58	1-216-655-11	s	METAL, CHIP 1.5K 0.5% 1/10W (2012)
R59	1-216-662-11	s	METAL, CHIP 3.0K 0.5% 1/10W (2012)
R60	1-216-662-11	s	METAL, CHIP 3.0K 0.5% 1/10W (2012)
R61	1-216-611-11	s	METAL, CHIP 22 0.5% 1/10W (2012)
R62	1-216-611-11	s	METAL, CHIP 22 0.5% 1/10W (2012)
R63	1-216-667-11	s	METAL, CHIP 4.7K 0.5% 1/10W (2012)
R64	1-216-662-11	s	METAL, CHIP 3.0K 0.5% 1/10W (2012)
R65	1-216-662-11	s	METAL, CHIP 3.0K 0.5% 1/10W (2012)
R66	1-216-662-11	s	METAL, CHIP 3.0K 0.5% 1/10W (2012)
R67	1-216-662-11	s	METAL, CHIP 3.0K 0.5% 1/10W (2012)
R68	1-216-611-11	s	METAL, CHIP 22 0.5% 1/10W (2012)
R69	1-216-611-11	s	METAL, CHIP 22 0.5% 1/10W (2012)
R70	1-216-611-11	s	METAL, CHIP 22 0.5% 1/10W (2012)
R71	1-216-611-11	s	METAL, CHIP 22 0.5% 1/10W (2012)
R72	1-216-611-11	s	METAL, CHIP 22 0.5% 1/10W (2012)
R73	1-216-611-11	s	METAL, CHIP 22 0.5% 1/10W (2012)
R74	1-216-611-11	s	METAL, CHIP 22 0.5% 1/10W (2012)
R75	1-216-611-11	s	METAL, CHIP 22 0.5% 1/10W (2012)
R76	1-216-662-11	s	METAL, CHIP 3.0K 0.5% 1/10W (2012)
R77	1-216-662-11	s	METAL, CHIP 3.0K 0.5% 1/10W (2012)
R78	1-216-662-11	s	METAL, CHIP 3.0K 0.5% 1/10W (2012)
R79	1-216-662-11	s	METAL, CHIP 3.0K 0.5% 1/10W (2012)
R80	1-216-655-11	s	METAL, CHIP 1.5K 0.5% 1/10W (2012)
R81	1-216-655-11	s	METAL, CHIP 1.5K 0.5% 1/10W (2012)
R82	1-216-655-11	s	METAL, CHIP 1.5K 0.5% 1/10W (2012)
R83	1-216-655-11	s	METAL, CHIP 1.5K 0.5% 1/10W (2012)
R84	1-216-629-11	s	METAL, CHIP 120 0.5% 1/10W (2012)
R85	1-216-629-11	s	METAL, CHIP 120 0.5% 1/10W (2012)
R86	1-216-629-11	s	METAL, CHIP 120 0.5% 1/10W (2012)
R87	1-216-629-11	s	METAL, CHIP 120 0.5% 1/10W (2012)
R88	1-216-681-11	s	METAL, CHIP 18K 0.5% 1/10W (2012)
R89	1-216-681-11	s	METAL, CHIP 18K 0.5% 1/10W (2012)
R90	1-216-681-11	s	METAL, CHIP 18K 0.5% 1/10W (2012)
R91	1-216-681-11	s	METAL, CHIP 18K 0.5% 1/10W (2012)
R92	1-216-681-11	s	METAL, CHIP 18K 0.5% 1/10W (2012)
R93	1-216-681-11	s	METAL, CHIP 18K 0.5% 1/10W (2012)
R94	1-216-681-11	s	METAL, CHIP 18K 0.5% 1/10W (2012)
R95	1-216-681-11	s	METAL, CHIP 18K 0.5% 1/10W (2012)
R96	1-216-298-00	s	METAL, CHIP 2.2 5% 1/10W (2012)
R97	1-216-298-00	s	METAL, CHIP 2.2 5% 1/10W (2012)
R98	1-216-298-00	s	METAL, CHIP 2.2 5% 1/10W (2012)
R99	1-216-298-00	s	METAL, CHIP 2.2 5% 1/10W (2012)
R100	1-216-651-11	s	METAL, CHIP 1.0K 0.5% 1/10W (2012)
R101	1-216-651-11	s	METAL, CHIP 1.0K 0.5% 1/10W (2012)
R102	1-216-651-11	s	METAL, CHIP 1.0K 0.5% 1/10W (2012)
R103	1-216-651-11	s	METAL, CHIP 1.0K 0.5% 1/10W (2012)
R104	1-216-651-11	s	METAL, CHIP 1.0K 0.5% 1/10W (2012)
R105	1-216-651-11	s	METAL, CHIP 1.0K 0.5% 1/10W (2012)
R106	1-216-651-11	s	METAL, CHIP 1.0K 0.5% 1/10W (2012)
R107	1-216-651-11	s	METAL, CHIP 1.0K 0.5% 1/10W (2012)
R108	1-216-308-00	s	METAL, CHIP 4.7 5% 1/10W (2012)
R109	1-216-308-00	s	METAL, CHIP 4.7 5% 1/10W (2012)
R110	1-216-308-00	s	METAL, CHIP 4.7 5% 1/10W (2012)

(ADA-55 BOARD)

Ref. No. or Q'ty	Part No.	SP	Description
R111	1-216-308-00	s	METAL, CHIP 4.7 5% 1/10W (2012)
R112	1-216-308-00	s	METAL, CHIP 4.7 5% 1/10W (2012)
R113	1-216-308-00	s	METAL, CHIP 4.7 5% 1/10W (2012)
R114	1-216-308-00	s	METAL, CHIP 4.7 5% 1/10W (2012)
R115	1-216-308-00	s	METAL, CHIP 4.7 5% 1/10W (2012)
R116	1-216-308-00	s	METAL, CHIP 4.7 5% 1/10W (2012)
R117	1-216-308-00	s	METAL, CHIP 4.7 5% 1/10W (2012)
R118	1-216-308-00	s	METAL, CHIP 4.7 5% 1/10W (2012)
R119	1-216-308-00	s	METAL, CHIP 4.7 5% 1/10W (2012)
R120	1-216-308-00	s	METAL, CHIP 4.7 5% 1/10W (2012)
R121	1-216-308-00	s	METAL, CHIP 4.7 5% 1/10W (2012)
R122	1-216-308-00	s	METAL, CHIP 4.7 5% 1/10W (2012)
R123	1-216-308-00	s	METAL, CHIP 4.7 5% 1/10W (2012)
R140	1-216-639-11	s	METAL, CHIP 330 0.5% 1/10W (2012)
R141	1-216-662-11	s	METAL, CHIP 3.0K 0.5% 1/10W (2012)
R142	1-216-603-11	s	METAL, CHIP 10 0.5% 1/10W (2012)
R143	1-216-639-11	s	METAL, CHIP 330 0.5% 1/10W (2012)
R144	1-216-662-11	s	METAL, CHIP 3.0K 0.5% 1/10W (2012)
R145	1-216-603-11	s	METAL, CHIP 10 0.5% 1/10W (2012)
R146	1-216-649-11	s	METAL, CHIP 820 0.5% 1/10W (2012)
R147	1-216-649-11	s	METAL, CHIP 820 0.5% 1/10W (2012)
R148	1-216-699-11	s	METAL, CHIP 100K 0.5% 1/10W (2012)
R149	1-216-699-11	s	METAL, CHIP 100K 0.5% 1/10W (2012) (S/N 10001 to 11870)
R201	1-216-615-11	s	METAL, CHIP 33 0.5% 1/10W (2012) (S/N 10001 to 10290)
R202	1-216-615-11	s	METAL, CHIP 33 0.5% 1/10W (2012) (S/N 10001 to 10290)
RB2	1-236-907-11	s	RES, NETWORK, CHIP 100Kx4 (3216) (S/N 10001 to 11870)
RV1	1-227-144-21	s	RES, ADJ, 50 (S/N 10291 and Higher)
	1-237-028-11	s	RES, ADJ, CERMET 20 (S/N 10001 to 10290)
RV2	1-227-144-21	s	RES, ADJ, 50 (S/N 10291 and Higher)
	1-237-028-11	s	RES, ADJ, CERMET 20 (S/N 10001 to 10290)
RV3	1-230-749-21	s	RES, ADJ, CERMET 5K
RV4	1-230-749-21	s	RES, ADJ, CERMET 5K
S1	*2 1-771-709-31	s	SWITCH, SLIDE
	*1 1-553-977-00	s	SWITCH, SLIDE
S2	*2 1-771-709-31	s	SWITCH, SLIDE
	*1 1-553-977-00	s	SWITCH, SLIDE

 CN-1855/1856 BOARD

Ref. No. or Q'ty	Part No.	SP Description
1pc	3-202-610-02	o PANEL (753A), CN
2pcs	3-686-054-02	o STUD, SUPPORT, PC BOARD
4pcs	7-621-775-10	s SCREW +B 2.6x4
2pcs	7-688-002-11	s WASHER 2.6, MIDDLE

The components in the connector panel assembly of BKPF-L753A are out of spare parts except above. When component replacement (except above) is required, replace by assembly (including CN-1855/1856 mounted circuit boards) below.

A-8322-760-A o CN PANEL (753A) ASSY

 DD-36 BOARD ;For S/N 10001-S/N 17325

*1:[Board No. suffix -11]
 *2:[Board No. suffix -12]

Ref. No. or Q'ty	Part No.	SP Description
1pc	A-8322-755-A	o MOUNTED CIRCUIT BOARD, DD-36
C1	1-115-339-11	s CERAMIC, CHIP 0.1uF 10% 50V (2012)
C2	1-164-182-11	s CERAMIC, CHIP 0.033uF 10% 50V(2012)
C3	1-126-394-11	s ELECT, CHIP 10uF 20% 16V
C4	1-109-982-11	s CERAMIC, CHIP 1.0uF 10% 10V (2012)
C5	1-164-182-11	s CERAMIC, CHIP 0.033uF 10% 50V(2012)
C6	1-109-982-11	s CERAMIC, CHIP 1.0uF 10% 10V (2012)
C7	1-109-982-11	s CERAMIC, CHIP 1.0uF 10% 10V (2012)
C8	1-127-518-11	s ALUMN SOLID 100uF 20% 16V
C10	1-127-518-11	s ALUMN SOLID 100uF 20% 16V
C11	1-127-518-11	s ALUMN SOLID 100uF 20% 16V
C13	1-115-339-11	s CERAMIC, CHIP 0.1uF 10% 50V (2012)
CN1	1-793-560-11	o CONNECTOR, PC BOARD, 7P, MALE
CN2	1-793-561-11	o CONNECTOR, PC BOARD, 9P, MALE
D1	8-719-065-59	s DIODE MBR0530T1
D2	8-719-065-59	s DIODE MBR0530T1
D3	8-719-065-59	s DIODE MBR0530T1
D4	8-719-065-59	s DIODE MBR0530T1
IC1	8-759-466-72	s IC MAX742CWP
L1	1-469-541-11	s COIL, CHOKE 47uH
L2	1-469-541-11	s COIL, CHOKE 47uH
Q1	8-729-045-16	s TRANSISTOR SI4410DY
Q2	8-729-045-53	s TRANSISTOR SI4431DY
R1	*2 1-208-758-11	s RESISTOR,CHIP 100 1/10W (2012)
	*1 1-216-627-11	s METAL, CHIP 100 0.5% 1/10W (2012)
R2	1-219-706-11	s METAL, CHIP 0.1 1% 1W (6432)
R3	1-219-706-11	s METAL, CHIP 0.1 1% 1W (6432)

Section 4

Semiconductor Pin Assignments

ここに記載されている半導体は、それぞれの機能を等価的に表したものです。なお、互換性のない型名を併記していることがありますので、部品を交換するときは、Spare Partsの章を参照してください。
等価回路はICメーカーのデータブックに従いました。

Semiconductors of which functions are equivalent are described here. For parts replacement, refer to the section of Spare Parts in this manual. The circuit diagram of each IC is obtained from the IC data book published by the manufacturer.

DIODE	Page	LED	Page	TRANSISTOR	Page	IC	Page
MBR0530T1	4-2	CL-155UR/G-D	4-2	2SA1162G	4-2	MAX742CWP-TE2	4-3
				2SA1358-Y	4-2	NJM5534M	4-3
				2SA812-T1-M5M6	4-2	NJM5534M(TE2)	4-3
				2SC1623	4-2		
				2SC1623-T1-L5L6	4-2		
				2SC3421-Y	4-2	PCF8574AT	4-3
				SI4410DY-T1-REVA	4-2		
				SI4431DY-T1	4-2		
				UN2221	4-2		
				UN2221-TX	4-2		

DIODE

—TOP VIEW—

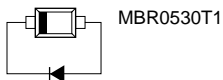

LED

CL-155UR/G-D

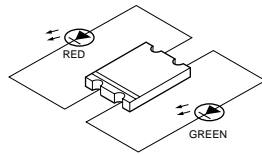

TRANSISTOR

—TOP VIEW—

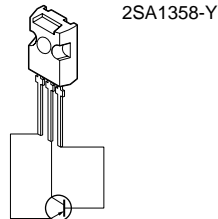
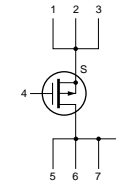
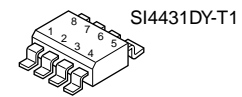
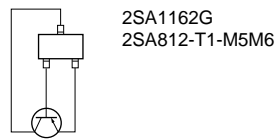

—TOP VIEW—

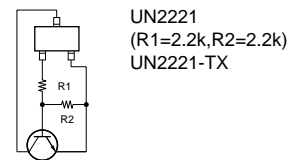

—TOP VIEW—

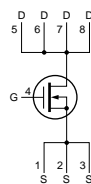
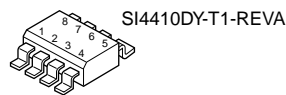
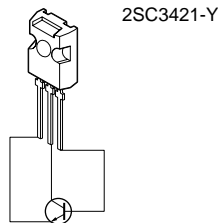
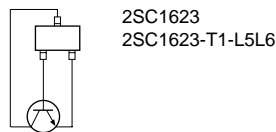

IC

MAX742CWP-TE2 (MAXIM)

DUAL-OUTPUT, SWITCH-MODE REGULATOR
—TOP VIEW—

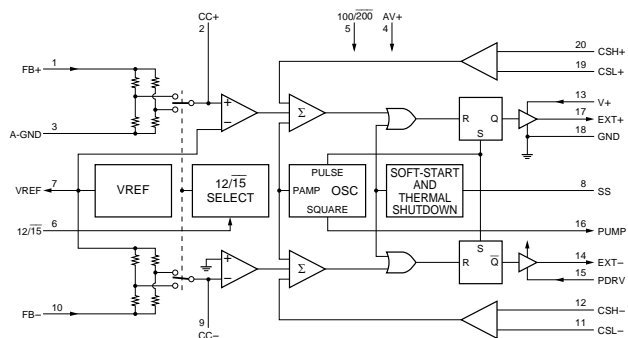
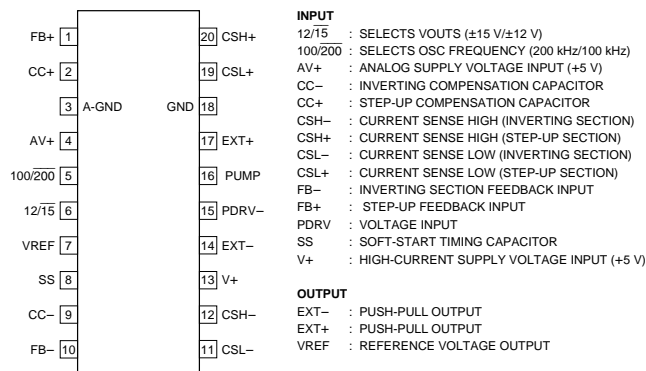

NJM5534M (JRC)
NJM5534M(TE2)

OPERATIONAL AMPLIFIER
—TOP VIEW—

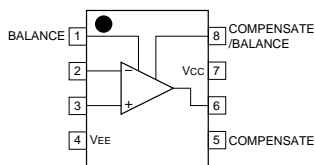

PCF8574AT (PHILIPS)

C-MOS REMOTE 8-BIT I/O EXPANDER
—TOP VIEW—

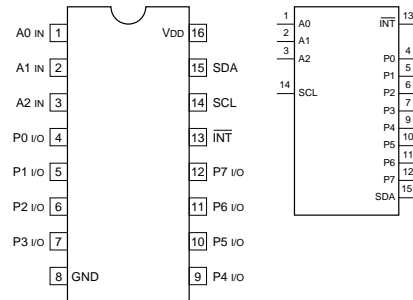

INPUT

- A0 - A2 : ADDRESS INPUTS
- SCL : SYSTEM CLOCK LINE

OUTPUT

- INT : INTERRUPT OUTPUT
- SDA : SERIAL DATA LINE

INPUT/OUTPUT

- P0 - P7 : 8-BIT QUASI-BIDIRECTIONAL I/O PORT

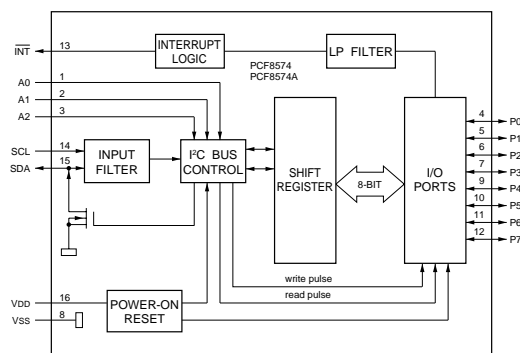

Section 5 Block Diagram

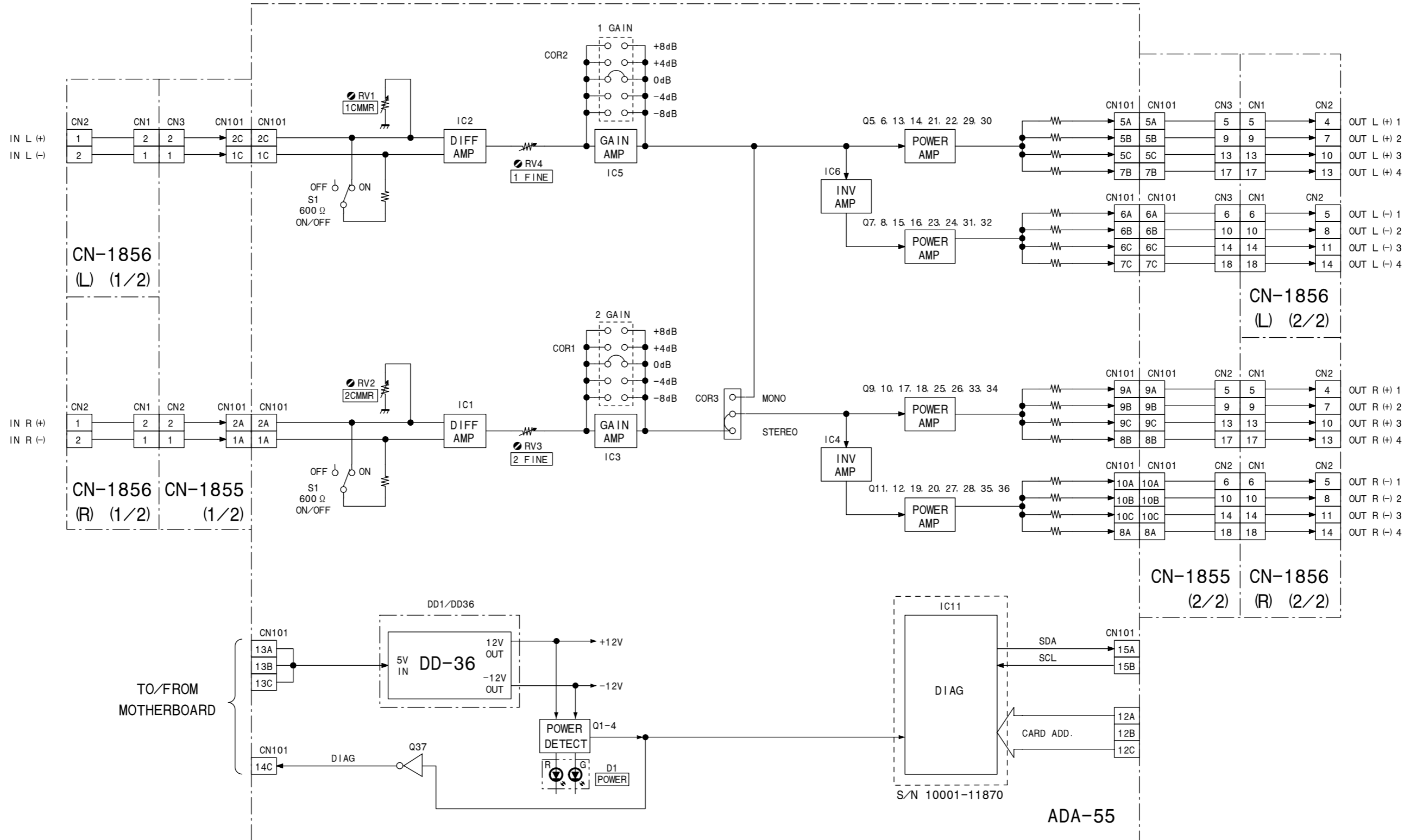

Section 6 Schematic Diagrams

Index

Board Name	Function	Page
ADA-55 Board	Analog Audio Distribution Board	6-2
CN-1855/1856 Boards	Connector Board	6-3
DD-36 Board	DC-DC Converter Board	6-4

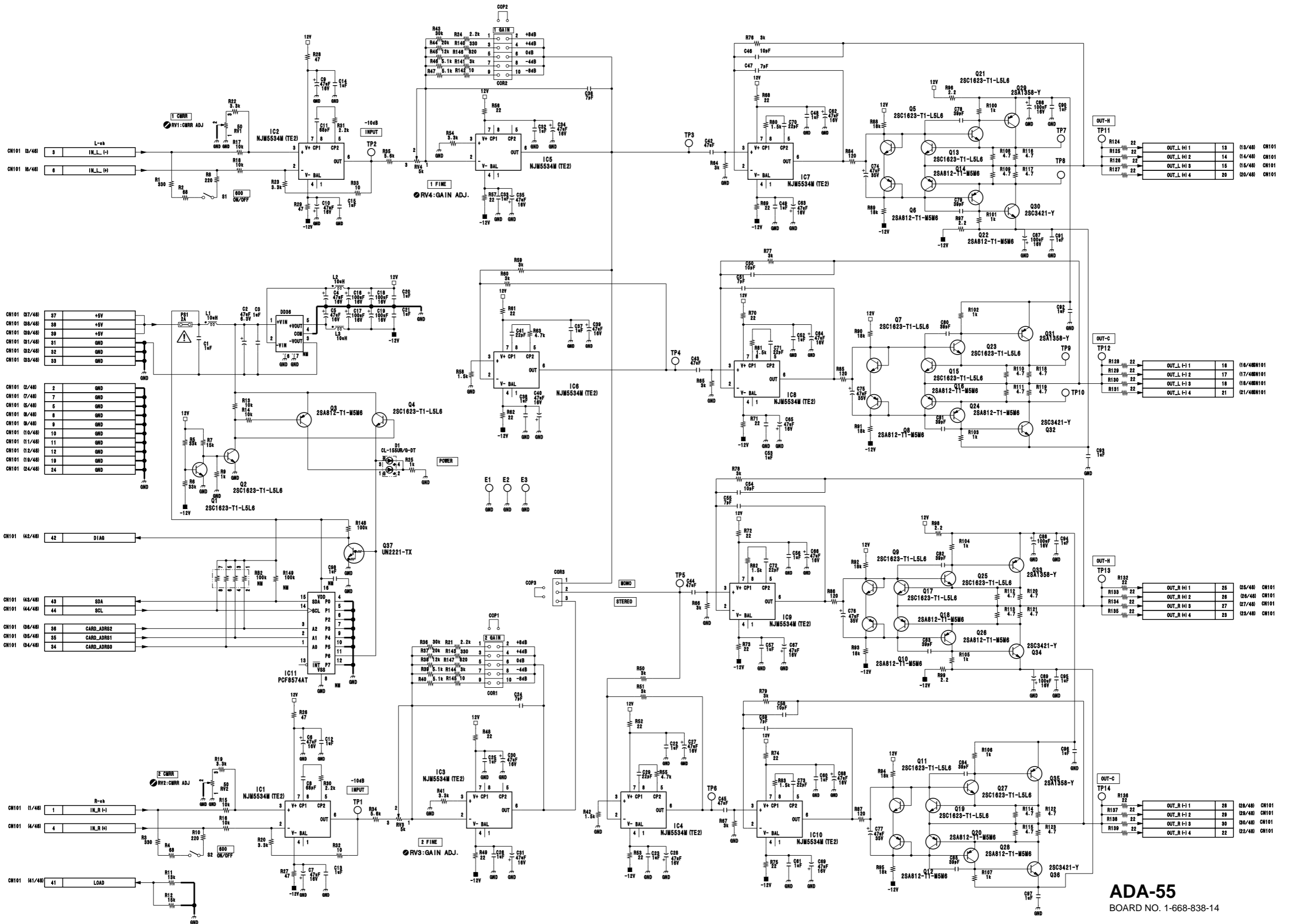

ADA-55 BOARD NO. 1-668-838-14

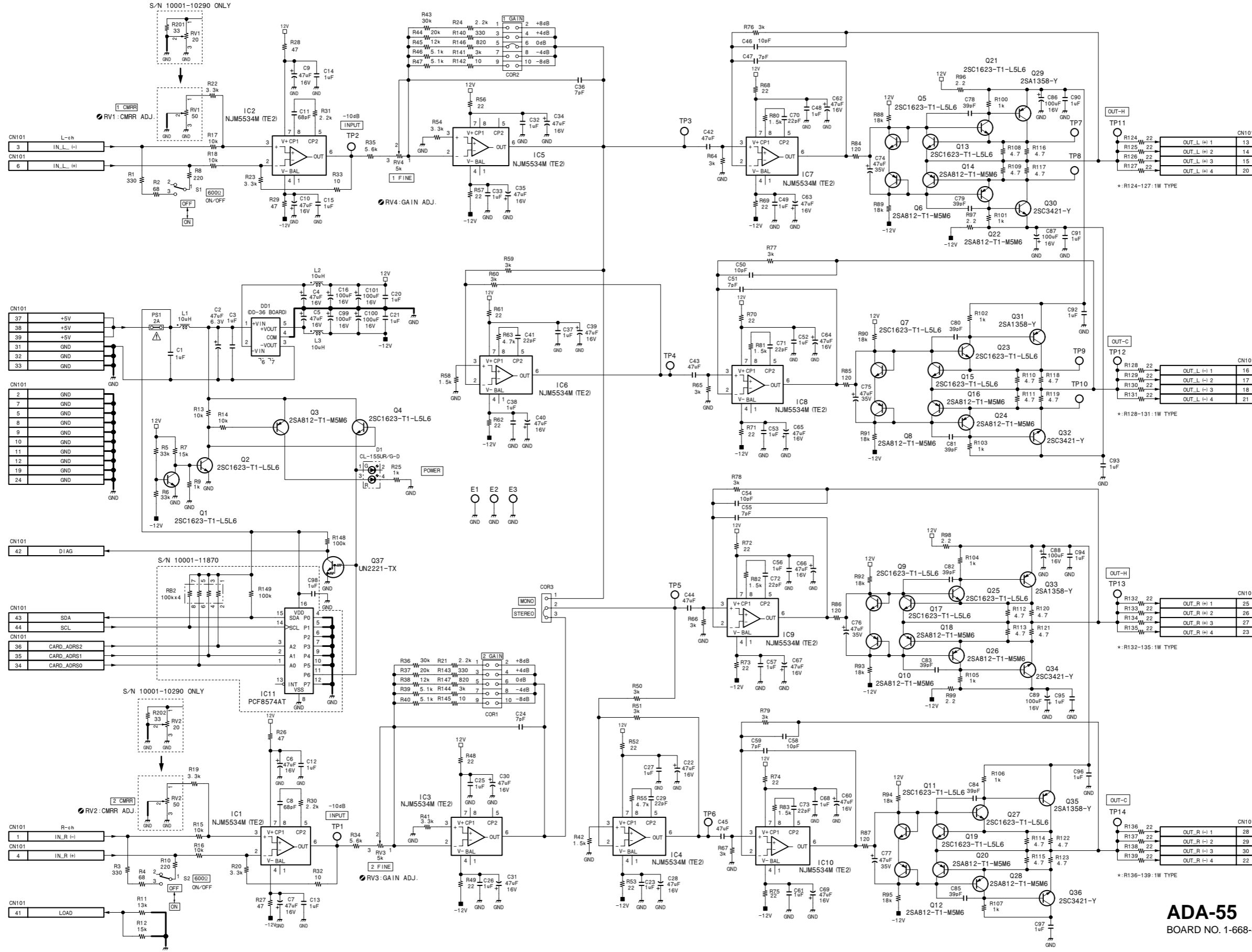

6-2 (a)

6-2 (a)

ADA-55
BOARD NO. 1-668-838-11, 12

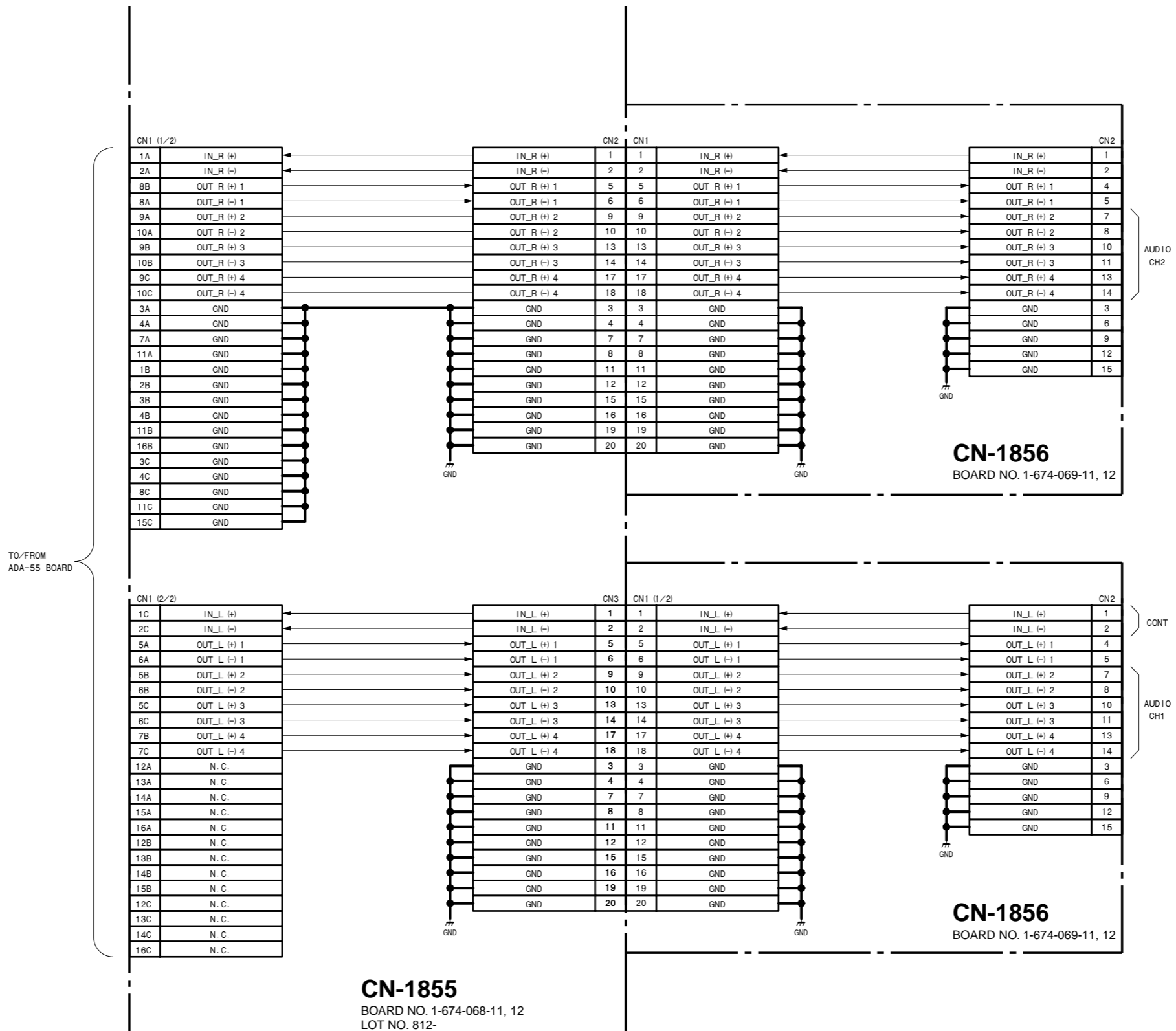

1

2

3

4

5

BKPF-L753A (SY) : S/N 10001 through 17325

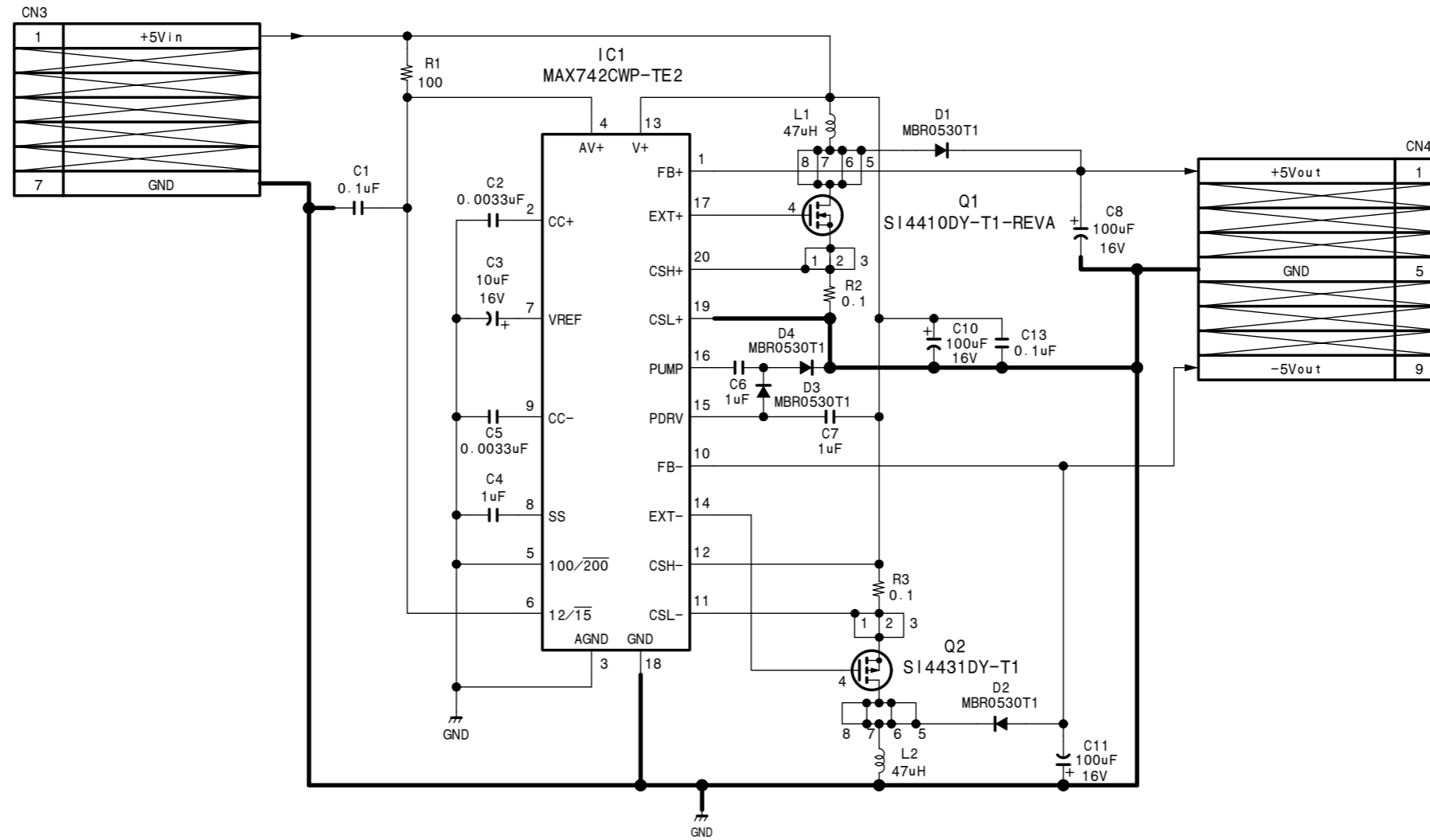

DD-36
 BOARD NO. 1-674-689-11, 12
 LOT NO. 902-3A5

Section 7
Board Layouts

ADA-55(1-668-838-14)

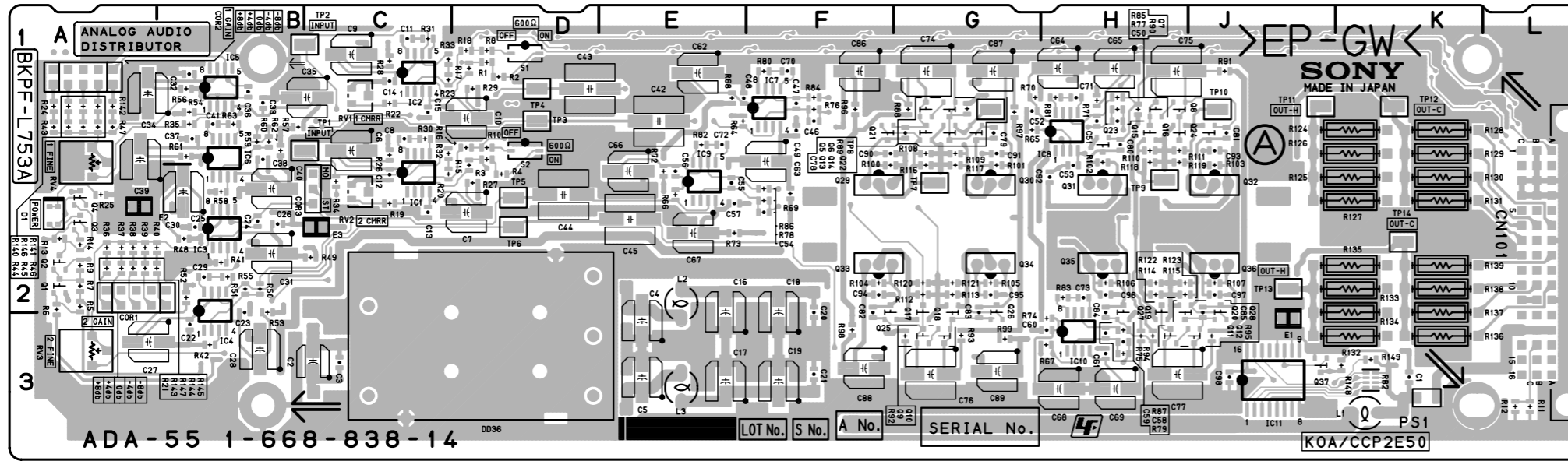

ADA-55 -A SIDE-
SUFFIX: -14

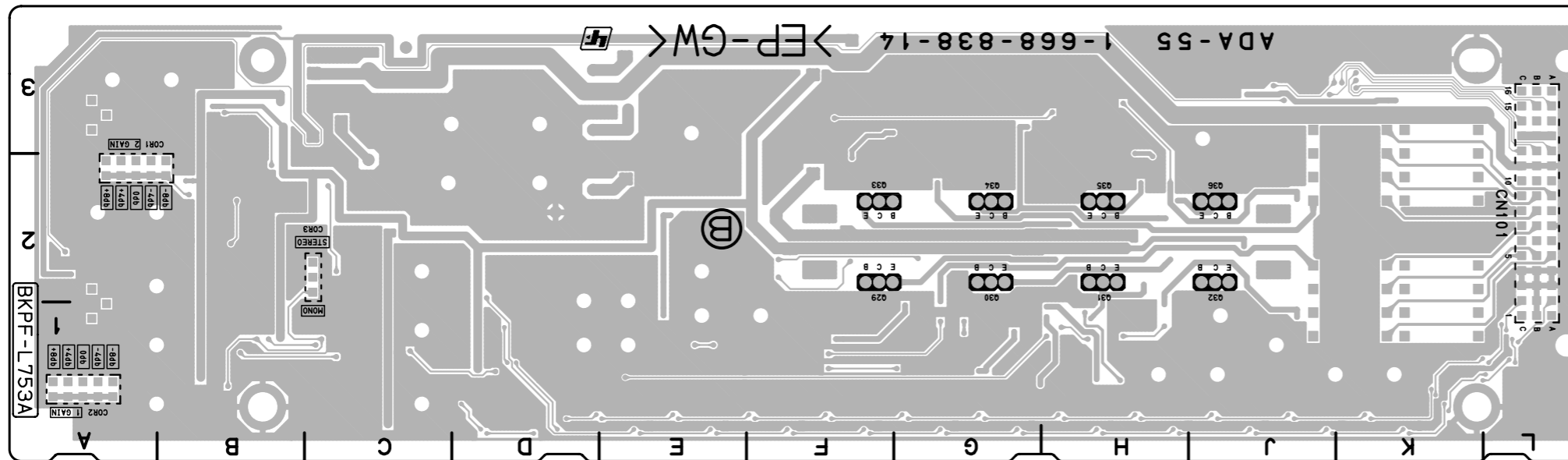

ADA-55 -B SIDE-
SUFFIX: -14

C1	K3	C94	F2	R18	D1	R111	H1
C2	C3	C95	G2	R19	C2	R112	G2
C3	C3	C96	H2	R20	C2	R113	G2
C4	E3	C97	J2	R21	A2	R114	H2
C5	E3	C98	J3	R22	C1	R115	H2
C6	C1			R23	C1	R116	G2
C7	D2	CN101	L2	R24	A1	R117	G2
C8	C1			R25	A2	R118	H1
C9	C1	COR1	A2	R26	C1	R119	H1
C10	D1	COR2	A1	R27	D2	R120	G2
C11	C1	COR3	C2	R28	C1	R121	G2
C12	C2			R29	D1	R122	H2
C13	C2	D1	A2	R30	C1	R123	H2
C14	C1			R31	C1	R124	K1
C15	C1	DD36	D3	R32	C1	R125	K2
C16	E2			R33	C1	R126	K1
C17	E3	E1	J3	R34	C2	R127	K2
C18	F2	E2	A2	R35	B1	R128	K1
C19	F3	E3	C2	R36	A2	R129	K1
C20	F2			R37	A2	R130	K2
C21	F3	IC1	C2	R38	A2	R131	K2
C22	B3	IC2	C1	R39	A2	R132	K3
C23	B2	IC3	B2	R40	A2	R133	K2
C24	B2	IC4	B3	R41	B2	R134	K2
C25	B2	IC5	B1	R42	B3	R135	K2
C26	B2	IC6	B2	R43	A1	R136	K3
C27	A3	IC7	F1	R44	A1	R137	K2
C28	B3	IC8	H1	R45	A1	R138	K2
C29	B2	IC9	E2	R46	A1	R139	K2
C30	B2	IC10	H3	R47	A1	R140	A1
C31	B2	IC11	J3	R48	B2	R141	A1
C32	B1			R49	C2	R142	A1
C33	B1	L1	K3	R50	B2	R143	A2
C34	A1	L2	E2	R51	B2	R144	A2
C35	C1	L3	E3	R52	B2	R145	A2
C36	B1			R53	B2	R146	A1
C37	B1	PS1	K3	R54	B1	R147	A2
C38	B1			R55	B2	R148	K3
C39	A1	Q1	A2	R56	B1	R149	K3
C40	B2	Q2	A2	R57	B1		
C41	B1	Q3	A2	R58	B2	RB2	K3
C42	E1	Q4	A2	R59	B1		
C43	D1	Q5	G1	R60	B1	RV1	C1
C44	D2	Q6	G1	R61	B1	RV2	C2
C45	E2	Q7	H1	R62	B1	RV3	A3
C46	F1	Q8	H1	R63	B1	RV4	A1
C47	F1	Q9	G3	R64	E1		
C48	E1	Q10	G3	R65	G1	S1	D1
C49	F1	Q11	H3	R66	E2	S2	D1
C50	H1	Q12	J3	R67	H3		
C51	H1	Q13	G1	R68	E1	TP1	C1
C52	G1	Q14	G1	R69	F2	TP2	C1
C53	H2	Q15	H1	R70	G1	TP3	D1
C54	F2	Q16	H1	R71	H1	TP4	D1
C55	E2	Q17	G2	R72	E2	TP5	D2
C56	E2	Q18	G2	R73	E2	TP6	D2
C57	E2	Q19	H2	R74	H3	TP7	G2
C58	H3	Q20	H2	R75	H3	TP8	G1
C59	H3	Q21	F1	R76	F1	TP9	H2
C60	H3	Q22	G1	R77	H1	TP10	J1
C61	H3	Q23	H1	R78	F2	TP11	J1
C62	E1	Q24	J1	R79	H3	TP12	K1
C63	F1	Q25	F2	R80	F1	TP13	J2
C64	H1	Q26	G2	R81	H1	TP14	K2
C65	H1	Q27	H2	R82	E1		
C66	E2	Q28	J2	R83	H2		
C67	E2	Q29	F2	R84	F1		
C68	H3	Q30	G2	R85	H1		
C69	H3	Q31	H2	R86	F2		
C70	F1	Q32	J2	R87	H3		
C71	H1	Q33	F2	R88	G1		
C72	E1	Q34	G2	R89	G1		
C73	H2	Q35	H2	R90	H1		
C74	G1	Q36	J2	R91	J1		
C75	H1	Q37	J3	R92	G3		
C76	G3			R93	G3		
C77	H3	R1	D1	R94	H3		
C78	G1	R2	D1	R95	J3		
C79	G1	R3	D1	R96	F1		
C80	H1	R4	D2	R97	G1		
C81	F1	R5	A2	R98	F3		
C82	F2	R6	A2	R99	G3		
C83	G2	R7	A2	R100	F2		
C84	H2	R8	D1	R101	G2		
C85	J2	R9	A2	R102	H1		
C86	F1	R10	D1	R103	J2		
C87	G1	R11	L3	R104	F2		
C88	F3	R12	L3	R105	G2		
C89	G3	R13	A2	R106	H2		
C90	F1	R14	A2	R107	J2		
C91	G1	R15	D2	R108	G1		
C92	H2	R16	D1	R109	G1		
C93	J1	R17	D1	R110	H1		

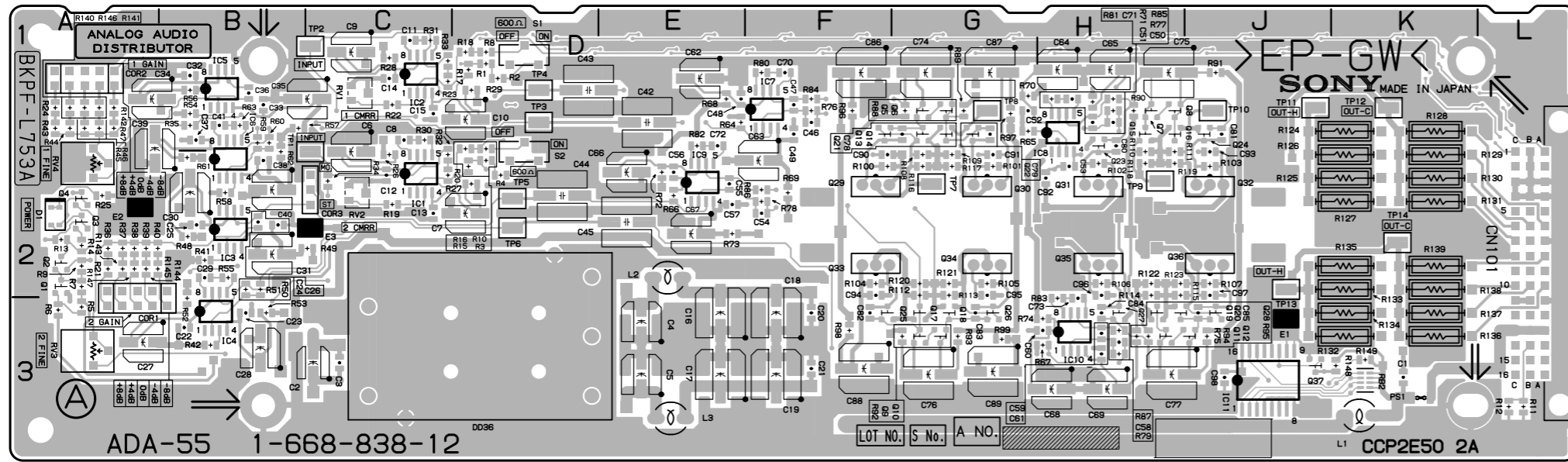

ADA-55 -A SIDE-
 SUFFIX: -11, 12

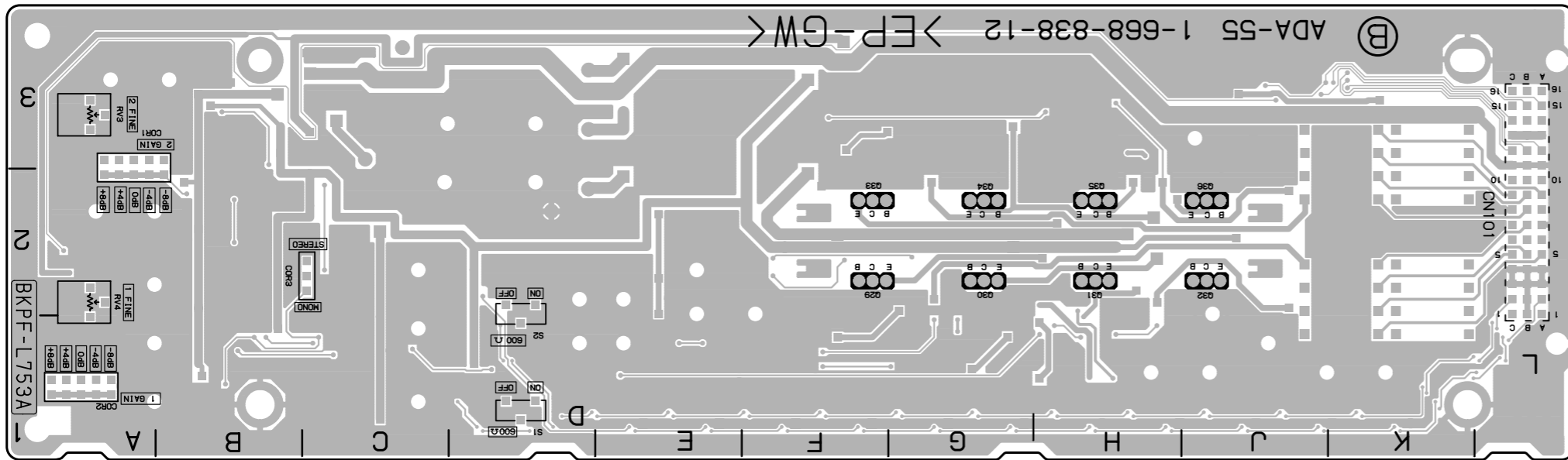

ADA-55 -B SIDE-
 SUFFIX: -11, 12

ADA-55(1-668-838-11, 12)

C1	K3	C94	F2	R18	D1	R111	H2
C2	C3	C95	G2	R19	C2	R112	G2
C3	C3	C96	H2	R20	C2	R113	G2
C4	E3	C97	J2	R21	A2	R114	H2
C5	E3	C98	J3	R22	C1	R115	H2
C6	C2			R23	C1	R116	G2
C7	D2	CN101	L2	R24	A1	R117	G2
C8	C1			R25	A2	R118	H2
C9	C1	COR1	A2	R26	C2	R119	H2
C10	D1	COR2	A1	R27	D2	R120	G2
C11	C1	COR3	C2	R28	C1	R121	G2
C12	C2			R29	D1	R122	H2
C13	C2	D1	A2	R30	C1	R123	H2
C14	C1			R31	C1	R124	K1
C15	C1	DD36	D3	R32	C2	R125	K2
C16	E3			R33	C1	R126	K2
C17	E3	E1	J3	R34	C2	R127	K2
C18	F3	E2	A2	R35	B1	R128	K1
C19	F3	E3	C2	R36	A2	R129	K2
C20	F3			R37	A2	R130	K2
C21	F3	IC1	C2	R38	A2	R131	K2
C22	B3	IC2	C1	R39	A2	R132	K3
C23	B3	IC3	B2	R40	B2	R133	K2
C24	B2	IC4	B3	R41	B2	R134	K3
C25	B2	IC5	B1	R42	B3	R135	K2
C26	B2	IC6	B2	R43	A1	R136	K3
C27	A3	IC7	F1	R44	A1	R137	K3
C28	B3	IC8	H2	R45	A1	R138	K2
C29	B2	IC9	E2	R46	A1	R139	K2
C30	B2	IC10	H3	R47	A1	R140	A1
C31	B2	IC11	J3	R48	B2	R141	A1
C32	B1			R49	C2	R142	A1
C33	B1	L1	K3	R50	B2	R143	A2
C34	A1	L2	E2	R51	B2	R144	A2
C35	C1	L3	E3	R52	B2	R145	B2
C36	B1			R53	B3	R146	A1
C37	B1	PS1	K3	R54	B1	R147	A2
C38	B2			R55	B2	R148	K3
C39	A1	Q1	A2	R56	B1	R149	K3
C40	B2	Q2	A2	R57	B1		
C41	B1	Q3	A2	R58	B2	RB2	K3
C42	E1	Q4	A2	R59	B1		
C43	D1	Q5	G1	R60	B1	RV1	C1
C44	D2	Q6	G1	R61	B2	RV2	C2
C45	E2	Q7	H1	R62	B2	RV3	A3
C46	F1	Q8	H1	R63	B1	RV4	A2
C47	F1	Q9	G3	R64	E1		
C48	E1	Q10	G3	R65	G1	S1	D1
C49	F1	Q11	H3	R66	E2	S2	D2
C50	H1	Q12	J3	R67	H3		
C51	H1	Q13	G1	R68	E1	TP1	C2
C52	G1	Q14	G1	R69	F2	TP2	C1
C53	H2	Q15	H1	R70	G1	TP3	D1
C54	F2	Q16	H1	R71	H1	TP4	D1
C55	E2	Q17	G3	R72	E2	TP5	D2
C56	E2	Q18	G3	R73	E2	TP6	D2
C57	E2	Q19	H3	R74	H3	TP7	G2
C58	H3	Q20	H3	R75	H3	TP8	G1
C59	H3	Q21	F1	R76	F1	TP9	H2
C60	H3	Q22	G1	R77	H1	TP10	J1
C61	H3	Q23	H1	R78	F2	TP11	J1
C62	E1	Q24	J1	R79	H3	TP12	K1
C63	F2	Q25	F3	R80	F1	TP13	J2
C64	H1	Q26	G3	R81	H1	TP14	K2
C65	H1	Q27	H3	R82	E1		
C66	E2	Q28	J3	R83	H2		
C67	E2	Q29	F2	R84	F1		
C68	H3	Q30	G2	R85	H1		
C69	H3	Q31	H2	R86	F2		
C70	F1	Q32	J2	R87	H3		
C71	H1	Q33	F2	R88	G1		
C72	E1	Q34	G2	R89	G1		
C73	H2	Q35	H2	R90	H1		
C74	G1	Q36	J2	R91	J1		
C75	H1	Q37	J3	R92	G3		
C76	G3			R93	G3		
C77	H3	R1	D1	R94	H3		
C78	G1	R2	D1	R95	J3		
C79	G1	R3	D2	R96	F1		
C80	H1	R4	D2	R97	G1		
C81	J1	R5	A3	R98	F3		
C82	F3	R6	A3	R99	G3		
C83	G3	R7	A2	R100	F2		
C84	H3	R8	D1	R101	G2		
C85	J3	R9	A2	R102	H2		
C86	F1	R10	D1	R103	J2		
C87	G1	R11	L3	R104	F2		
C88	F3	R12	L3	R105	G2		
C89	G3	R13	A2	R106	H2		
C90	F2	R14	A2	R107	J2		
C91	G2	R15	D2	R108	G2		
C92	H2	R16	D1	R109	G2		
C93	J2	R17	D1	R110	H2		

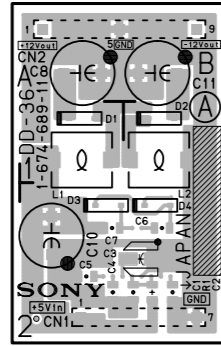

DD-36 -A SIDE-
SUFFIX: -11, 12

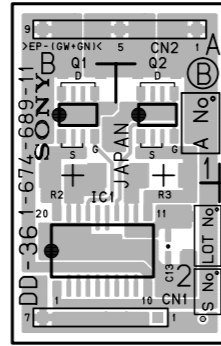

DD-36 -B SIDE-
SUFFIX: -11, 12

BKPF-L753A (SY) : S/N 10001 through 17325

DD-36(1-674-689-11, 12)

*:B SIDE

- | | |
|-----|-----|
| C1 | B2 |
| C2 | B2 |
| C3 | B2 |
| C4 | A2 |
| C5 | A2 |
| C6 | B2 |
| C7 | A2 |
| C8 | A1 |
| C10 | A2 |
| C11 | B1 |
| C13 | *A2 |
| | |
| CN1 | *B2 |
| CN2 | *A1 |
| | |
| D1 | A1 |
| D2 | B1 |
| D3 | A2 |
| D4 | B2 |
| | |
| IC1 | *B2 |
| | |
| L1 | A1 |
| L2 | B1 |
| | |
| Q1 | *B1 |
| Q2 | *A1 |
| | |
| R1 | B2 |
| R2 | *B1 |
| R3 | *A1 |

