

HP NC522SFP Dual Port 10 GbE Server Adapter User Guide



Part Number 537709-001
March 2009 (First Edition)

© Copyright 2009 Hewlett-Packard Development Company, L.P.

The information contained herein is subject to change without notice. The only warranties for HP products and services are set forth in the express warranty statements accompanying such products and services. Nothing herein should be construed as constituting an additional warranty. HP shall not be liable for technical or editorial errors or omissions contained herein.

Intended audience

This document is for the person who installs, administers, and troubleshoots servers and storage systems. HP assumes you are qualified in the servicing of computer equipment and trained in recognizing hazards in products with hazardous energy levels.

Contents

Technician notes	4
Warnings, cautions, and notes.....	4
Downloading files	5
HP contact information.....	5
Introduction	6
Overview	6
LED indicators.....	6
Installing an adapter	9
Installation overview	9
Preventing electrostatic discharge	9
Installing an adapter in a server	10
Installing a low profile bracket	10
Connecting the network cable.....	11
Specifications.....	12
Cable specifications	12
General specifications	12
Compliance.....	12
Power and environmental specifications	13
Regulatory compliance notices	14
Regulatory compliance identification numbers.....	14
Federal Communications Commission notice.....	14
European Union regulatory notice	14
Canadian notice	15
Korean class A notice	15
Japanese class A notice	15
Disposal of waste equipment by users in private households in the European Union.....	15
Electrostatic discharge.....	16
Preventing electrostatic discharge	16
Grounding methods to prevent electrostatic discharge.....	16
Acronyms and abbreviations.....	17
Index.....	18

Technician notes

Warnings, cautions, and notes

 **WARNING:** Only authorized technicians trained by HP should attempt to repair this equipment. All troubleshooting and repair procedures are detailed to allow only subassembly/module-level repair. Because of the complexity of the individual boards and subassemblies, no one should attempt to make repairs at the component level or to make modifications to any printed wiring board. Improper repairs can create a safety hazard.

 **WARNING:** To reduce the risk of electric shock, personal injury, and damage to the equipment:

- Do not attempt to service any parts of the equipment other than those specified in the following procedure. Any other activities may require that you shut down the server and remove the power cord.
- Installation and maintenance of this product must be performed by individuals who are knowledgeable about the procedures, precautions and hazards associated with the product.

 **WARNING:** To reduce the risk of electric shock or damage to the equipment:

- Do not disable the power cord grounding plug. The grounding plug is an important safety feature.
- Plug the power cord into a grounded (earthed) electrical outlet that is easily accessible at all times.
- Unplug the power cord from the power supply to disconnect power to the equipment.
- Do not route the power cord where it can be walked on or pinched by items placed against it. Pay particular attention to the plug, electrical outlet, and the point where the cord extends from the server.



This symbol indicates the presence of a hot surface or hot component. If this surface is contacted, the potential for injury exists.

WARNING: To reduce the risk of injury from a hot component, allow the surface to cool before touching.

 **CAUTION:** To properly ventilate the system, you must provide at least 7.6 cm (3.0 in) of clearance at the front and back of the server.

 **CAUTION:** The server is designed to be electrically grounded (earthed). To ensure proper operation, plug the AC power cord into a properly grounded AC outlet only.

NOTE: Any indications of component replacement or printed wiring board modifications may void any warranty.

Downloading files

1. Go to the HP website (<http://www.hp.com/#Support>).
2. Select **Download drivers and software (and firmware)**.
3. Type the adapter name in the **For product** box and then click **Go**. For example, type NC522SFP.
4. Download the drivers, firmware, or documentation as needed.

HP contact information

For the name of the nearest HP authorized reseller:

- See the Contact HP worldwide (in English) webpage (<http://welcome.hp.com/country/us/en/wwcontact.html>).

For HP technical support:

- In the United States, for contact options see the Contact HP United States webpage (http://welcome.hp.com/country/us/en/contact_us.html). To contact HP by phone:
 - Call 1-800-HP-INVENT (1-800-474-6836). This service is available 24 hours a day, 7 days a week. For continuous quality improvement, calls may be recorded or monitored.
 - If you have purchased a Care Pack (service upgrade), call 1-800-633-3600. For more information about Care Packs, refer to the HP website (<http://www.hp.com/hps>).
- In other locations, see the Contact HP worldwide (in English) webpage (<http://welcome.hp.com/country/us/en/wwcontact.html>).

Introduction

Overview

The HP NC522SFP Dual Port 10 GbE Server Adapter is a dual port PCI Express (PCIe) 10 Gigabit ProLiant Ethernet adapter. The network connection is made through two 10GBASE-SFP+ modules.

In addition to standard HP network server adapter features, the NC522SFP is capable of supporting teaming for load balancing and failover, TCP checksum and segmentation (LSO) offload capability, VLAN tagging, jumbo frames, IPv6, and other features. The NC522SFP can be installed in either standard or low profile slots.

LED indicators

The NC522SFP adapter has two ports with LED indicators for Link and Act. (activity) for each port. Standard-height and low-profile brackets are shown below with the fiber LC port and LED indicators.

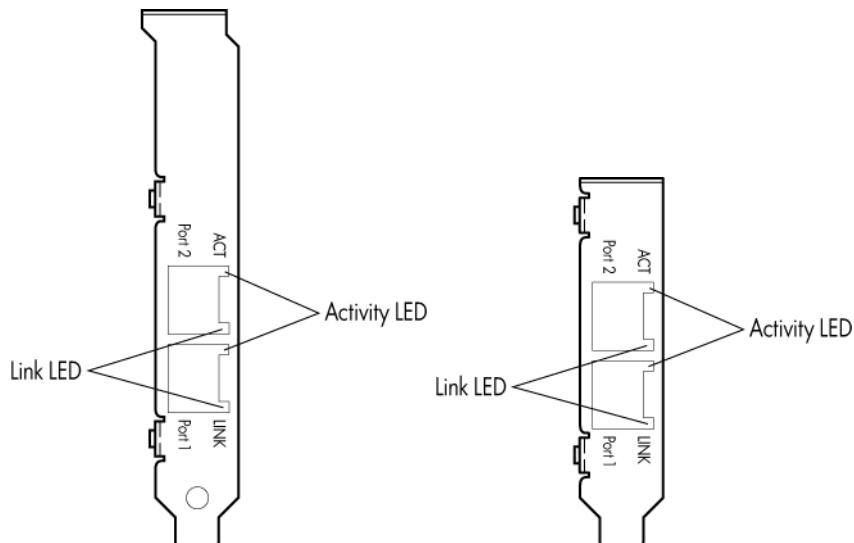

The NC522SFP 10 Gigabit Server Adapter LED indicators operate as described in the following table.

LED indicator	Status	Description
Act.	Off	Indicates no network activity on the link.
	Flashing (Green)	Indicates network activity on the link. The adapter is sending or receiving network data at up to 10Gbps.
Link	Off	No link to the adapter is established. The adapter is not receiving power or the cable connection is faulty.

LED indicator	Status	Description
	On (Green)	Link to the adapter is established. The adapter is receiving power and the cable connection is good.

HP Direct Attach copper cables, fiber optic cable, and SFP+ module part numbers are listed in the following tables.

Direct attach copper cable (0.5 - 10 m)	Part number
HP 0.5 m SFP+ 10 GbE Copper Cable	487649-B21
HP 1 m SFP+ 10 GbE Copper Cable	487652-B21
HP 3 m SFP+ 10 GbE Copper Cable	487655-B21
HP 7 m SFP+ 10 GbE Copper Cable	487658-B21

Fiber Optic Cable (0.5 to 50 m)	Part number
HP 2 m LC-LC Multi-Mode OM2 Fiber Optic Cable	221692-B21
HP 5 m LC-LC Multi-Mode OM2 Fiber Optic Cable	221692-B22
HP 15 m LC-LC Multi-Mode OM2 Fiber Optic Cable	221692-B23
HP 30 m LC-LC Multi-Mode OM2 Fiber Optic Cable	221692-B26
HP 50 m LC-LC Multi-Mode OM2 Fiber Optic Cable	221692-B27
HP .5 m LC-LC Multi-Mode OM3 Fiber Optic Cable	AJ833A
HP 1 m LC-LC Multi-Mode OM3 Fiber Optic Cable	AJ834A

HP 2 m LC-LC Multi-Mode OM3 Fiber Optic Cable	AJ835A
HP 5 m LC-LC Multi-Mode OM3 Fiber Optic Cable	AJ836A
HP 15 m LC-LC Multi-Mode OM3 Fiber Optic Cable	AJ837A
HP 30 m LC-LC Multi-Mode OM3 Fiber Optic Cable	AJ838A
HP 50 m LC-LC Multi-Mode OM3 Fiber Optic Cable	AJ839A

SFP+ module	Part number
HP BladeSystem 10Gb SR SFP+	455883-B21
HP BladeSystem 10Gb LR SFP+	455886-B21
HP BladeSystem 10Gb LRM SFP+	455889-B21

Installing an adapter

Installation overview

This section describes installation precautions, how to install the adapter, and how to connect the network cable.



WARNING: To reduce the risk of personal injury or damage to the equipment, consult the safety information and user documentation provided with the server before attempting the installation.

Many servers are capable of providing energy levels that are considered hazardous and are intended to be serviced only by qualified personnel who have been trained to deal with these hazards. Do not remove enclosures or attempt to bypass any interlocks that may be provided for the purpose of removing these hazardous conditions.



WARNING: Installation of this adapter should be performed by individuals who are both qualified in the servicing of computer equipment, and trained in the hazards associated with products capable of producing hazardous energy levels.

This adapter is intended to be installed in Certified (UL or CSA) ITE equipment having instructions for adding and removing user installed components such as PCI, PCI-X, and PCI Express devices. Refer to the equipment instructions to verify that it is suitable for user installed components and that it has the power capacity to support all of the installed components.

NOTE: Before removing the cover of your server, refer to the HP documentation for the proper methods for installing a PCI Express card and avoiding electric shock hazards.

Preventing electrostatic discharge

To prevent damaging the system, be aware of the precautions you need to follow when setting up the system or handling parts. A discharge of static electricity from a finger or other conductor may damage system boards or other static-sensitive devices. This type of damage may reduce the life expectancy of the device.

To prevent electrostatic damage:

- Avoid hand contact by transporting and storing products in static-safe containers.
- Keep electrostatic-sensitive parts in their containers until they arrive at static-free workstations.
- Place parts on a grounded surface before removing them from their containers.
- Avoid touching pins, leads, or circuitry.
- Always be properly grounded when touching a static-sensitive component or assembly.

Installing an adapter in a server

See the HP ProLiant server documentation for additional information on how to safely install a PCI Express card in the server.

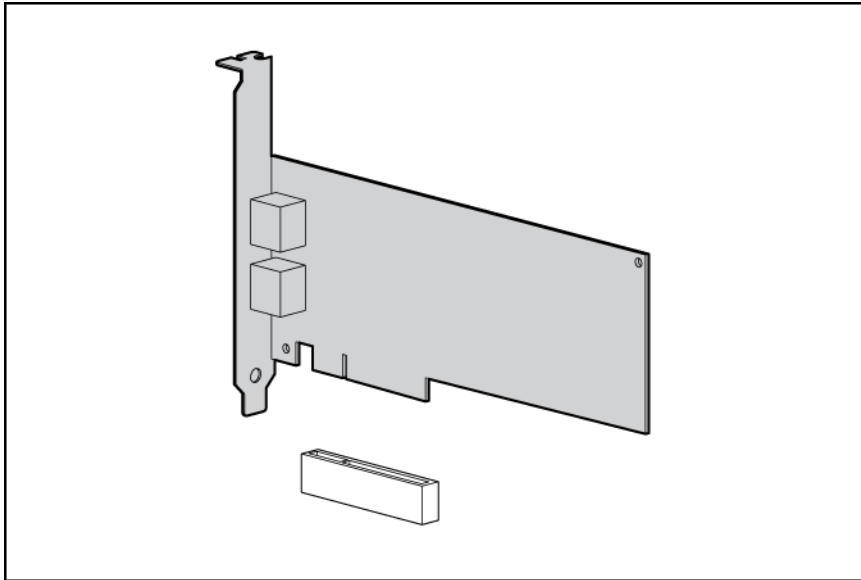

⚠ CAUTION: If the server is not PCI Hot Plug compliant, power it down and unplug the power cord from the power outlet before removing the server access panel. Failure to do so may damage the adapter or server.

1. Power down the server.
2. Remove the power cord and server access panel. Then remove the cover bracket from a PCI Express slot.

⚠ WARNING: To reduce the risk of personal injury from a hot component, allow the surface of the option card to cool before touching it.

⚠ WARNING: To reduce the risk of personal injury from hot surfaces, allow the drives and the internal system components to cool before touching them.

3. Firmly seat the adapter in a PCI Express slot and secure the adapter bracket.

NOTE: For 1U type servers you may need to replace the standard profile bracket with a low profile bracket. See [Installing a low profile bracket](#).

4. Replace the access panel and plug in the power cord.

Installing a low profile bracket

You may have to install a low profile bracket to complete the product installation. The low profile bracket replaces the existing standard profile bracket shipped on the product.

1. Remove the SFP modules by pulling down on the bail latch handle located near the connector, and then pulling the SFP modules out.

2. Using a correctly sized Phillips head screwdriver, carefully remove the two board lock screws located at the top and bottom of the connector.
3. Remove the standard profile bracket and place the low profile bracket over the connector. Be careful not to damage the connector or bend the low profile bracket.
4. Reinstall the two Phillips screws.
5. Orient the SFP modules with the label side down and then reinstall the modules all the way into their sockets until they click into place and latch securely.

Connecting the network cable

The HP NC522SFP Dual Port 10 GbE Server Adapter uses two SFP+ ports. These ports support either direct attached cable or optical modules. See Cable specifications (on page [12](#)) for the maximum cable length.

Specifications

Cable specifications

SFP+ modules or copper cable	Fiber type	Cable grade	Minimum modal bandwidth @ 850 nm (MHz-km)	Operating range (meters)
10GBASE-SR (short range)	62.5 μ m MMF	FDDI	160	2 to 26
	62.5 μ m MMF	OM1	200	2 to 33
	50 μ m MMF	OM2	500	2 to 82
	50 μ m MMF	OM3	2000	2 to 300
10GBASE-LRM (long reach multimode)	50, 62.5 μ m MMF	OM1, OM2, OM3	N/A	0.5 to 220
10GBASE-LR (long range)	10 μ m SMF	B1.1, B1.3 SMF	N/A	2 to 10,000
Direct attached copper	Twin Axial Copper	@26 AWG	N/A	.5 - 10

General specifications

General specifications	Value
Controller	NETXEN NX3031
Data rate	10Gbps, full-duplex
PCI bus	8 Lane (x8) PCI Express Gen 2, compatible with x4 and x8 bus widths
Connectors	2 SFP+
Dimensions (LxW)	6.6 x 2.7 inches (16.734 cm x 6.85 cm) without bracket

Compliance

Compliance	Standard
IEEE	IEEE802.3x, IEEE802.3ad, IEEE802.1p, IEEE802.1q, IEEE802.3z, IEEE802.3ae
Safety	UL Mark (US and Canada) EN 60950

Compliance	Standard
Other	PCIe v2.0 RoHS 6 of 6 IPv4, IPv6 CE ACPI 1.1a Microsoft WHQL (Windows Hardware Quality Labs) Server Design Guide version 3.0 (SDG 3.0)

Power and environmental specifications

Power and environmental specifications	Value
Operating	Temperature 32° to 131° F (0° to 55° C) Humidity 10% to 90%
Non-operating	Temperature -85° to 185° F (-65° to 85° C) Humidity 5% to 95%
Power	2.03A @ 12 V and 570 mA @ 3.3 V maximum

Regulatory compliance notices

Regulatory compliance identification numbers

For the purpose of regulatory compliance certifications and identification, this product has been assigned a unique regulatory model number. The regulatory model number can be found on the product nameplate label, along with all required approval markings and information. When requesting compliance information for this product, always refer to this regulatory model number. The regulatory model number is not the marketing name or model number of the product.

Federal Communications Commission notice

This equipment has been tested and found to comply with the limits for a Class A digital device, pursuant to Part 15 of the FCC Rules. These limits are designed to provide reasonable protection against harmful interference when the equipment is operated in a commercial environment. This equipment generates, uses, and can radiate radio frequency energy and, if not installed and used in accordance with the instructions, may cause harmful interference to radio communications. Operation of this equipment in a residential area is likely to cause harmful interference, in which case the user will be required to correct the interference at personal expense.

European Union regulatory notice

This product complies with the following EU Directives:

- Low Voltage Directive 2006/95/EC
- EMC Directive 2004/108/EC

Compliance with these directives implies conformity to applicable harmonized European standards (European Norms) which are listed on the EU Declaration of Conformity issued by Hewlett-Packard for this product or product family.

This compliance is indicated by the following conformity marking placed on the product:



This marking is valid for non-Telecom products and EU harmonized Telecom products (e.g. Bluetooth).



This marking is valid for EU non-harmonized Telecom products.

*Notified body number (used only if applicable—refer to the product label)

Hewlett-Packard GmbH, HQ-TRE, Herrenberger Strasse 140, 71034 Boeblingen, Germany

Canadian notice

This Class A digital apparatus meets all requirements of the Canadian Interference-Causing Equipment Regulations.

Cet appareil numérique de la classe A respecte toutes les exigences du Règlement sur le matériel brouilleur du Canada.

Korean class A notice

A급 기기 (업무용 방송통신기기)	이 기기는 업무용(A급)으로 전자파적합등록을 한 기기이오니 판매자 또는 사용자는 이 점을 주의하시기 바라며, 가정 외의 지역에서 사용하는 것을 목적으로 합니다.
-----------------------	---

Japanese class A notice

この装置は、情報処理装置等電波障害自主規制協議会（VCCI）の基準に基づくクラスA情報技術装置です。この装置を家庭環境で使用すると電波妨害を引き起こすことがあります。この場合には使用者が適切な対策を講ずるよう要求されることがあります。

Disposal of waste equipment by users in private households in the European Union



This symbol on the product or on its packaging indicates that this product must not be disposed of with your other household waste. Instead, it is your responsibility to dispose of your waste equipment by handing it over to a designated collection point for the recycling of waste electrical and electronic equipment. The separate collection and recycling of your waste equipment at the time of disposal will help to conserve natural resources and ensure that it is recycled in a manner that protects human health and the environment. For more information about where you can drop off your waste equipment for recycling, please contact your local city office, your household waste disposal service or the shop where you purchased the product.

Electrostatic discharge

Preventing electrostatic discharge

To prevent damaging the system, be aware of the precautions you need to follow when setting up the system or handling parts. A discharge of static electricity from a finger or other conductor may damage system boards or other static-sensitive devices. This type of damage may reduce the life expectancy of the device.

To prevent electrostatic damage:

- Avoid hand contact by transporting and storing products in static-safe containers.
- Keep electrostatic-sensitive parts in their containers until they arrive at static-free workstations.
- Place parts on a grounded surface before removing them from their containers.
- Avoid touching pins, leads, or circuitry.
- Always be properly grounded when touching a static-sensitive component or assembly.

Grounding methods to prevent electrostatic discharge

Several methods are used for grounding. Use one or more of the following methods when handling or installing electrostatic-sensitive parts:

- Use a wrist strap connected by a ground cord to a grounded workstation or computer chassis. Wrist straps are flexible straps with a minimum of 1 megohm ± 10 percent resistance in the ground cords. To provide proper ground, wear the strap snug against the skin.
- Use heel straps, toe straps, or boot straps at standing workstations. Wear the straps on both feet when standing on conductive floors or dissipating floor mats.
- Use conductive field service tools.
- Use a portable field service kit with a folding static-dissipating work mat.

If you do not have any of the suggested equipment for proper grounding, have an authorized reseller install the part.

For more information on static electricity or assistance with product installation, contact an authorized reseller.

Acronyms and abbreviations

CSA

Canadian Standards Association

DMA

direct memory access

IEEE

Institute of Electrical and Electronics Engineers

iSCSI

Internet Small Computer System Interface

PCI Express

Peripheral Component Interconnect Express

RDMA

Remote Direct Memory Access

RSS

Receive-Side Scaling

SFP

small form-factor pluggable

TOE

TCP/IP Offload Engine

Index

A

adapter LEDs 6
adapters 6

B

bracket, low profile 10

C

cables, networking 11
compliance 12, 14
contact information 5

D

disposal, waste 15
downloading files 5

E

electrostatic discharge 9, 16
environmental specifications 13

F

features 6

G

grounding methods 16

L

LC connector 11
LEDs 6
low profile bracket 10

P

PCI (peripheral component interface) 9
power specifications 13

R

regulatory compliance notices 14, 15

S

specifications 12, 13
standards 14

T

technical notes 4

V

ventilation 4

W

warnings 4