

Sunbeam

Oskar 400

Continuous Flow Food Processor

INSTRUCTION AND RECIPE BOOKLET



Sunbeam's Safety Precautions.

SAFETY PRECAUTIONS FOR YOUR FOOD PROCESSOR.

- Blade and Processing Disc are very sharp, handle with care when removing, replacing or cleaning.
- Ensure fingers are kept well away from the Processing Blade and the Slicing/Shredding Disc when in use.
- Use the food processor on a dry, flat level surface.
- Never place Processing Blade on the Base without first putting the Container properly in place.
- Be certain, Container Cover is securely locked in place while operating appliance.
- Never feed food by hand, always use Food Pusher.
- Never use the food processor outdoors.
- Never remove the Cover or Processor until the Blade or Disc has come to a complete stop and the unit has been unplugged from a power outlet.

SAFETY PRECAUTIONS FOR ALL ELECTRICAL APPLIANCES

Sunbeam are very safety conscious when designing and manufacturing consumer products, but it is essential that the product user also exercise care when using an electrical appliance. Listed below are precautions which are essential for the safe use of an electrical appliance:

- Read carefully and save all the instructions provided with an appliance.
- Always turn the power off at the power outlet before you remove a plug. Remove by grasping the plug - do not pull on the cord.
- Turn the power off and remove the plug when the appliance is not in use and before cleaning.
- Do not use your appliance with an extension cord unless this cord has been checked and tested by your electricity supplier or qualified technician.
- Always use your appliance from a power outlet of the voltage (A.C. only) marked on the underside of the appliance.
- Close supervision is necessary when your appliance is being used near children or infirm persons.
- Never leave an appliance unattended while in use.
- Young children or infirm persons should be supervised to ensure that they do not play with the appliance.
- Do not use an appliance for any purpose other than its intended use.
- Do not place an appliance on or near a hot gas flame, electric element or in a heated oven. Do not place on top of any other appliance.
- Do not let the power cord of an appliance hang over the edge of a table or bench top or touch any hot surface.
- Do not immerse in water.
- For safety reasons and to avoid maintenance by unskilled persons, some appliances are 'sealed' using tamperproof means as specified by S.A.A. (Standards Association of Australia). Such appliances should always be returned to the nearest Service Centre for adjustment or repair if required.
- Do not operate any electrical appliance with a damaged cord or after the appliance has been dropped or damaged in any manner; if damage is suspected, return the appliance to the nearest Service Centre for examination, repair or adjustment. As a service to Customers, Service Centres will carry out a free check on your appliance to ensure it is electrically safe.
- For additional protection Sunbeam recommend the use of a residual current device (RCD) with a tripping current not exceeding 30mA in the electrical circuit supplying the power outlet in use.

If you have any concerns regarding the performance and use of your appliance, please ring our Toll Free number (Australia only) 1800 025 059. New Zealand - contact the Sunbeam Office in Auckland.

Ensure the above safety precautions are understood.

تأكد من تفهم احتياطات السلامة المذكورة اعلاه

請務必理解上述的安全預防措施。

Assurez-vous que les précautions ci-dessus relatives à la sécurité sont bien comprises

Versichern Sie sich daß die obenstehenden Sicherheitsmaßnahmen Verstanden werden

Βεβαιώσετε πως οι παραπάνω προφυλάξεις ασφαλείας γίνονται κατανοητές

Pastikan bahwa tindakan-tindakan keselamatan seperti di atas dimengerti anda

Accertatevi che le suddette norme di sicurezza siano comprese a dovere

上記の注意事項をよくお読みになり、安全を御確認ください

Уверете се дека погоре споменатите мерки на претпазливост се добро разбрани

Asegúrese de que las precauciones de seguridad precedentes sean bien comprendidas

کاری یکنید کہ احتیاط‌های بالا حتماً درک بشوند

ต้องแน่ใจว่า ข้อควรระวังเรื่องความปลอดภัยข้างต้น เป็นที่เข้าใจกันดี

Yukarda belirtilen güvenlik önlemlerinin anlaşılırdığınızdan emin olunuz

Xin kiểm chắc rằng những biện pháp làm an toàn kể trên được hiểu rõ

Features of you Sunbeam Oskar 400.

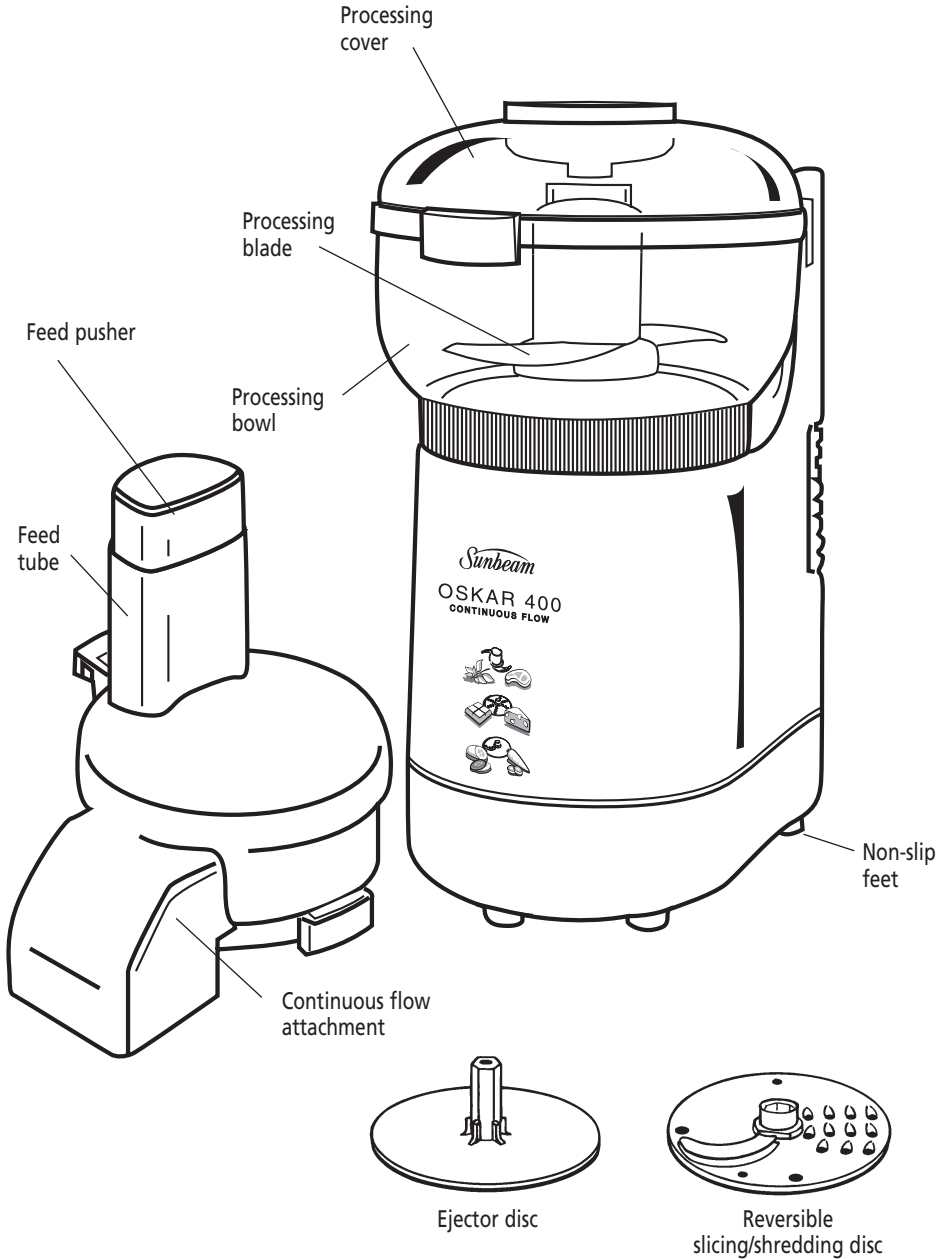

Features of you Sunbeam Oskar 400 (cont).

1. Powerful 400 watt motor

The base houses a powerful 400 watt motor, ideal even under heavy loads. Perfect for performing food preparation tasks including - chopping, mincing, pureeing, blending, mixing, shredding and slicing - quickly and efficiently.

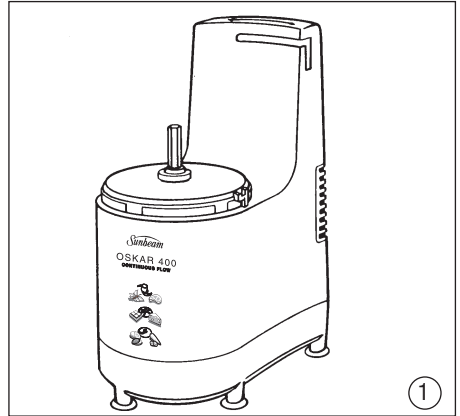

2. Processing Bowl

The processing bowl locks into place on the motor base. The shape, in combination with the design of the blade, ensures even, efficient processing. The transparency of the processing bowl allows you to check the food during processing and for additional convenience, the processing bowl is microwave safe and dishwasher safe.

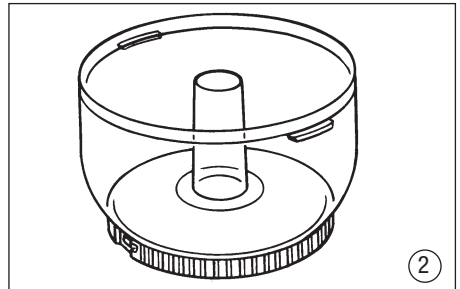

3. Processing blade

The stainless steel processing blade is contoured to fit the rounded shape of the processing bowl to provide a most efficient chopping/mixing action.

The processing blade is only to be used in the processing bowl.

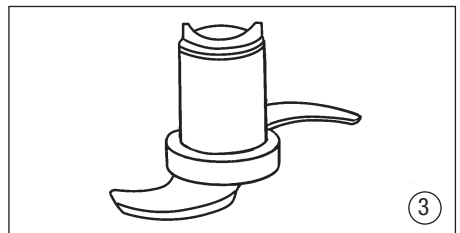

4. Cover

The transparent cover is the lid for the processing bowl and activates the automatic On/Off interlock switch system. The cover also has a pouring hole, so ingredients can be added gradually during processing.

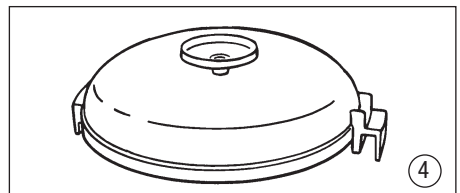

Features of you Sunbeam Oskar 400 (cont).

5. Ejector Disc

When using the Slicing/Shredding disc the ejector disc must first be placed over the drive shaft. As the food is sliced or shredded, it is thrown from the ejector disc, through the continuous flow attachment and into a waiting bowl on the side of the unit.

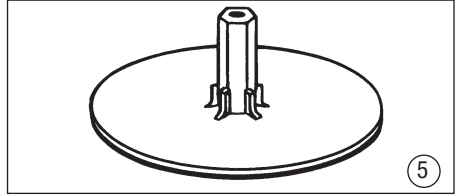

6. Reversible Slicing/Shredding disc

The easy clean stainless steel disc is reversible - one side will Slice and the other side will Shred. The disc is only suitable when using the continuous flow attachment.

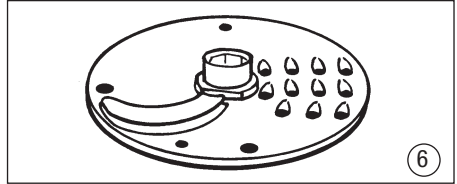

7. Continuous Flow attachment

This attachment locks onto the processing bowl in a similar manner to that of the processing bowl cover, and activates the automatic On/Off interlock switch system. The continuous flow attachment allows you to slice or shred unlimited amounts of food. A large bowl or suitable container is required to collect the processed food.

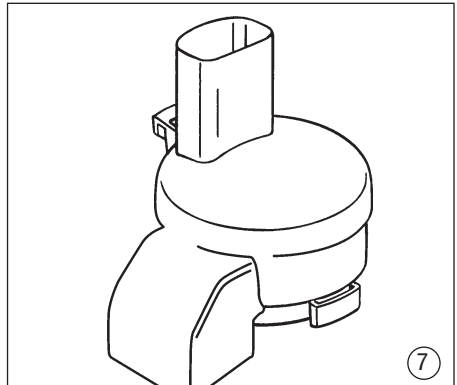

8. Food pusher

The food pusher is used with the continuous flow attachment. It guides food evenly down the feed tube and onto the Slicing/Shredding disc.

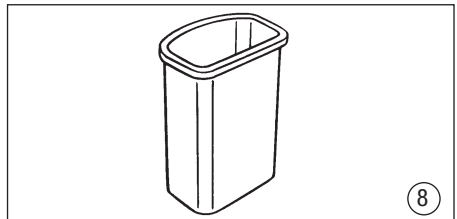

Using your Sunbeam Oskar 400.

Before using your Oskar 400

- Wash the processing bowl, cover, continuous flow attachment and all attachments in warm to hot water using a mild detergent. Dry each part thoroughly before use.
- Before you assemble the Oskar 400, ensure that the power cord is unplugged.

Using the processing bowl and cover

1. Set up the motor base facing you on a dry, level surface.

Note: The tallest side of the motor housing is to the rear.

2. Place the processing bowl over the drive shaft and rotate the container until it drops down evenly onto the base. Turn the processing bowl anti-clockwise firmly until it 'locks' into place (1).

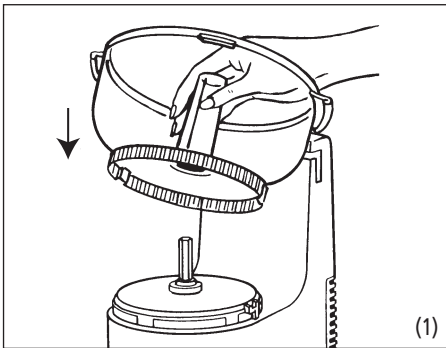

3. Fit the processing blade onto the drive shaft, rotating it slightly until it settles into place (2).

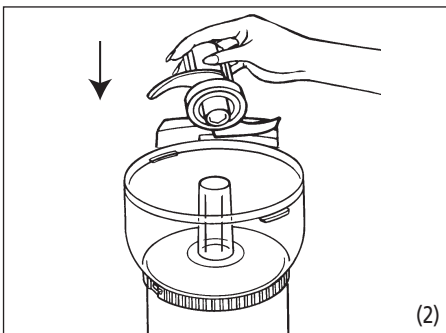

4. Place food in the food processor bowl.
5. Place the processing bowl cover on the processing bowl so that the large locking tab on the cover is to the right side of the bowl, near the horizontal slot at the back of the processing body (3).

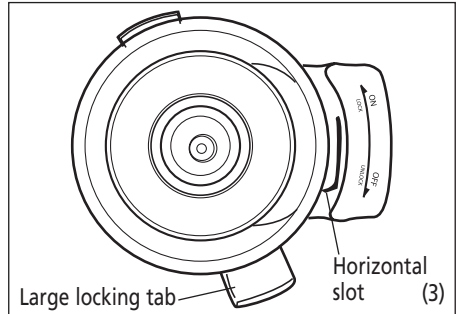

6. Plug in the food processor and turn the power 'ON'.
7. Turn the processing cover to the left (anti-clockwise), this will engage the automatic switch and the food processor will turn on (4).

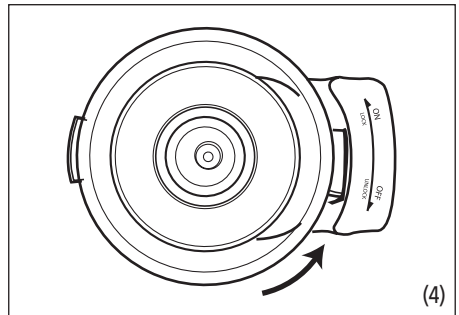

Note: Unless the locking tab on the processing bowl cover is engaged, the unit will not turn on.

Using your Sunbeam Oskar 400 (cont).

- When processing is complete, turn the cover to the right (clockwise), this will stop the food processor (5).

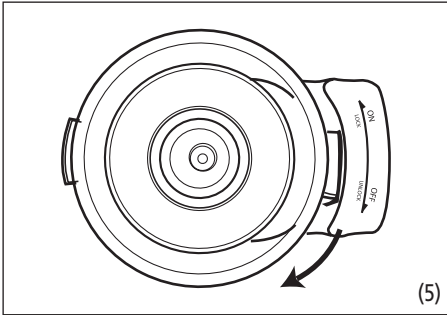

- Remove the processing blade from the bowl before removing the processed food.

Note: The stainless steel processing blade is only for use in the processing bowl, for in-bowl chopping, mixing or pureeing functions; NEVER in the continuous flow attachment.

Using continuous flow processing

- Set up the motor base facing you on a dry, level surface.

Note: The tallest side of the motor housing to the rear.

- Place the processing bowl over the drive shaft and rotate the container until it drops down evenly onto the base. Turn the processing bowl anti-clockwise firmly until it 'locks' into place (1).
- Place the ejector disc into the processing bowl by holding the shorter stem and placing the disc onto the drive shaft (6).

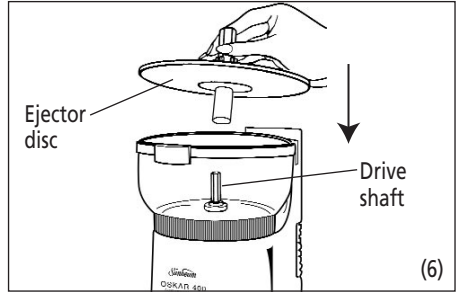

For Slicing:

- Hold the slicing/shredding disc with the raised slicing blade facing upwards. Place the slicing/shredding disc onto the drive shaft, sitting over the ejector disc (7).

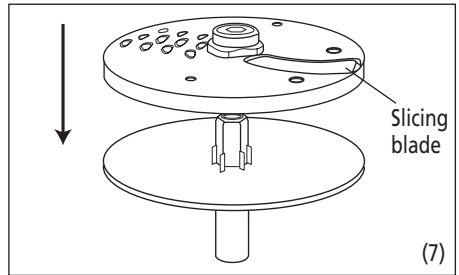

For Shredding:

- Hold the slicing/shredding disc with the series of raised small notches facing upwards. Place the slicing/shredding disc onto the drive shaft, sitting over the ejector disc (8).

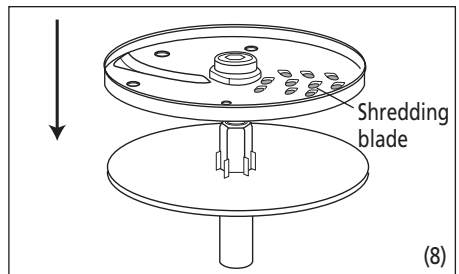

Using your Sunbeam Oskar 400 (cont).

5. Place the continuous flow attachment onto the top of the processing bowl, so that the pin on the continuous flow attachment slides into the hole at the top of the slicing/shredding disc. Ensure that the large locking tab on the continuous flow attachment is on the right-hand side, near the horizontal slot at the back of the processor body (9).

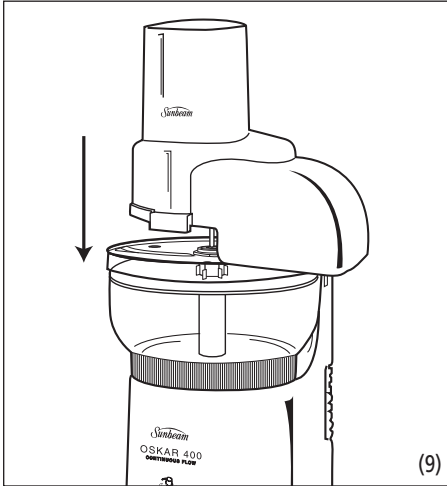

- 6. Plug in the food processor and turn the power 'ON'.
- 7. Load the feed tube with the food to be processed (10).

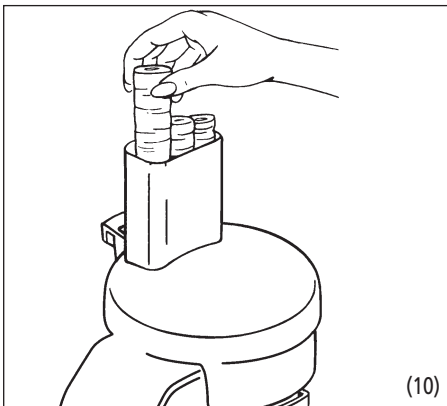

8. Place a bowl under the chute of the continuous flow attachment (11).

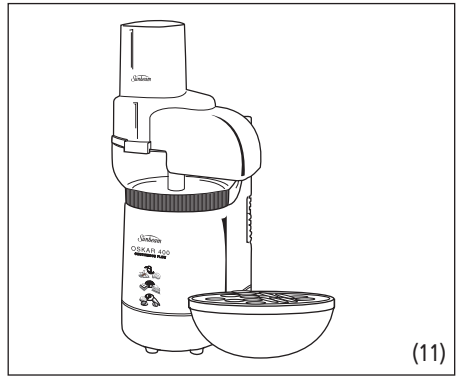

9. Rest the food pusher in the feed tube. Now, holding the food pusher with one hand and the feed tube with the other, turn the continuous flow attachment to the left (anti-clockwise) until the large tab slides into the horizontal slot at the back of the processor body. This will engage the automatic switch and the food processor will turn on (12).

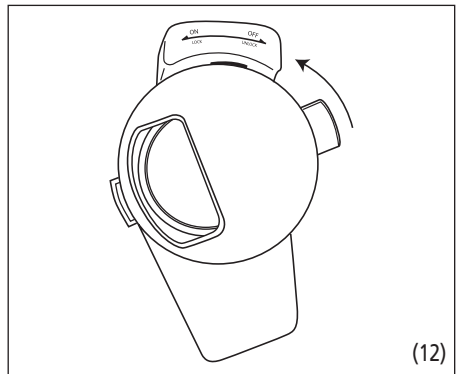

Note: Unless the locking tab on the continuous flow attachment is engaged, the unit will not turn on.

Using your Sunbeam Oskar 400 (cont).

10. Continue firmly pushing on the food pusher for better results (13).

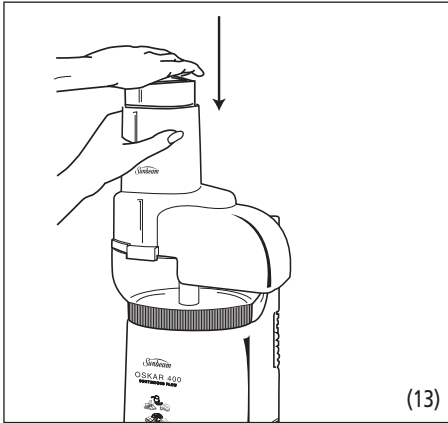

(13)

Note: Always keep fingers away from the continuous flow chute when the food processor is in operation.

11. When slicing/shredding is complete, turn the continuous flow attachment to the right (clockwise); this will stop the food processor (14).

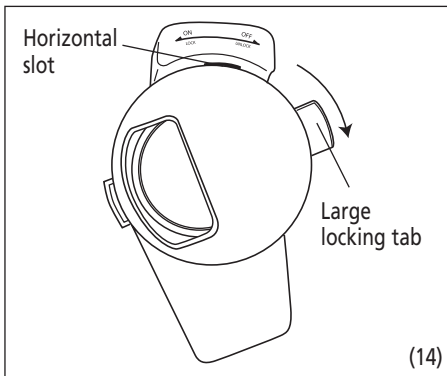

(14)

12. Remove the slicing/shredding disc and ejector disc from the processing bowl.

Note: The blades on the stainless steel slicing/shredding disc are only for use with the continuous flow attachment.

Disassembly

When processing is completed and the processing blade or slicing/shredding disc has been removed, remove the processing bowl. To do this simply turn the processing bowl to the right in a clockwise direction, until the bowl is unlocked (15).

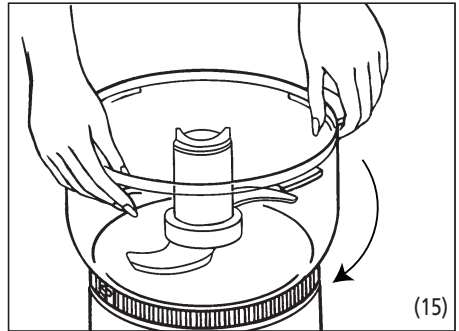

(15)

Handy Hints When Processing.

Chopping

For the best, most consistent results, you should try to process pieces of food that are approximately equal in size. When you break, cut or tear food into uniform pieces before you begin processing, the finished results will be more uniform.

More consistent processing results are achieved if the container is not overloaded.

Note: When processing a heavy load, check to be sure Oskar 400 is sitting firmly on the bench top.

Mincing

Pre-cut meat into cubes approximately 2cm square. Place the pieces in the processing bowl, replace the cover and process for 15-20 seconds or until evenly processed.

Vegetables

When processing vegetables such as onions, peel and quarter. Place into processing bowl and turn the unit 'On' and 'Off' 1 or 2 times to coarsely chop, 3 to 4 times to finely chop. Scrape sides of the container once or twice during processing if necessary.

Mixing

The quantities that can be processed within the processing bowl will vary with the density of the mixture.

Adding Ingredients

When various recipes require dry ingredients such as flour, add them directly into the processing bowl before processing. There is no need to shift ingredients when using your Oskar 400. Liquid ingredients may be added by pouring the required amount through the pouring hole in the cover.

Note: When processing sauces or semi-liquid ingredients, stop the food processor and scrape down the container sides and cover if necessary.

Blending

When blending liquids (eg: soup or drinks), apply pressure to the cover to prevent leakage. If contents are very hot, place a cloth over the cover, before applying pressure.

Using the Feed Tube

The most important factor for successful slicing and shredding is the way in which food is packed into the feed tube.

When Slicing and Shredding

Cut all ingredients to a size that fits comfortably into the feed tube. Pack the feed tube and while holding food steady and upright with the food pusher, press down evenly until all ingredients are sliced or shredded. The more firmly you push, the thicker the slices or shreds. Do not use excessive force or you may damage the Oskar 400.

Note: Never use fingers to push food down the feed tube. Always use the food pusher.

Handy Hints When Processing (cont).

For best results when slicing

The feed tube should always be packed firmly to allow each piece of food to support the others. There will always be a small portion of food left unprocessed between the food pusher and the slicing/shredding disc.

Preparing longer slices

Pack food items horizontally in the feed tube (16).

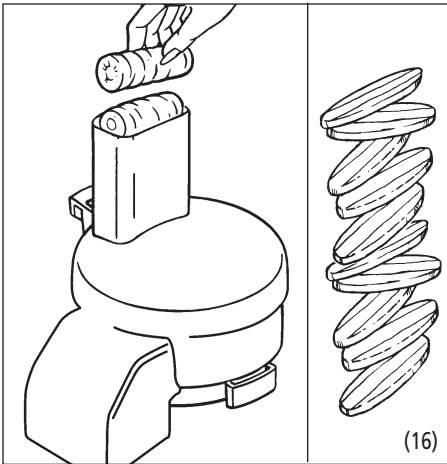

Preparing shorter slices

Pack food items vertically in the feed tube (17).

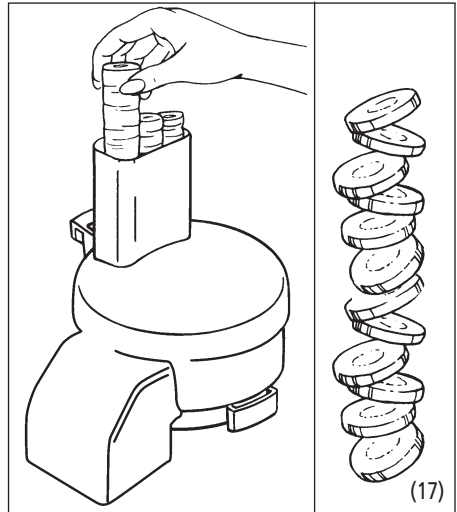

For best results when shredding

Remember that softer foods such as cheese (Cheddar, Mozzarella or Swiss) should be well chilled before processing. Harder foods such as Parmesan or Romano cheese should be at room temperature before processing. Cheese can also be chopped in the processing bowl.

Cleaning, storing and caring for Oskar 400.

When you have finished processing, unplug your Oskar 400 from the power outlet and remove the Cover, Slicing/Shredding Disc or Processing Blade and the Bowl from the Motor Base.

Motor Base

Wipe with a damp cloth.

Note: Never immerse in water or other liquid. Never use a harsh detergent or abrasive.

Processing Bowl, Cover and Food Pusher

Wash in warm to hot water using a mild detergent.

Processing Blade

To remove the processed ingredients, simply remove the processing blade with processed food clinging to it, then clean the blade with a spatula before emptying the remaining food from the processing container (18).

To clean inside the base shaft, use the back of a knife or spoon handle to get right inside.



Processing Blade and Slicing/Shredding Disc.

Wash in warm to hot water using a mild detergent. The internal shaft can be cleaned with a bottle brush and then dried thoroughly. If using a dishwasher, always place in top shelf away from the elements.

Sunbeam is a registered trademark. Oskar is a trademark of the Sunbeam Corporation. Made in China. Due to minor changes in design or otherwise, the product may differ from the one shown in this leaflet. Approved by the appropriate Electrical Regulatory Authorities. Backed by Sunbeam's 12 Month Replacement Guarantee and National Service Network.

Food Odours and Stains

Strong smelling foods like garlic, fish and some vegetables such as carrots may leave an odour or stain on the processing bowl. To remove odour from the processing bowl, always rinse with cold water first. To remove slight staining, place a small portion of bi-carbonate of soda onto a damp cloth and rub the stain. Allow to stand for a few minutes before washing up.

To remove more stubborn stains or odours, immerse processing bowl in water mixed with a little kitchen bleach and allow to stand overnight.

Wash with a mild detergent the following day and dry thoroughly. Store without lid in position until next required.

Note: Never use any chemical, steel wool, harsh abrasive cleaners, thinners or chemical dust cloths for cleaning any parts of your food processor.

Important: The processing blade and slicing/shredding disc are extremely sharp! Use caution when handling and storing these parts.

Dishwasher Safe

All plastic components deteriorate through the prolonged use of a dishwasher for cleaning.

However, parts of your Oskar 400 are tolerant to dishwasher use.

These include the processing blade, reversible slicing/shredding disc, ejector disc and the food pusher.

Note: Place only on the top rack of your dishwasher.

© Copyright. SUNBEAM CORPORATION LIMITED 2002. (INCORPORATED IN N.S.W.) A.C.N. 000 006 771

For more information or advice on this or any other Sunbeam appliance, visit www.sunbeam.com.au or contact the Sunbeam Consumer Service Line.

Australia 1800 025 059
New Zealand (09) 912 0747.

Oskar 400 Food Processing Guide.

Processing Task	Attachment & Accessory	Food Product	Processing Procedure to be used
Chopping	Processing Bowl fitted with Processing Blade.	Apples, cabbage, cooked fish & chicken, ham, hard boiled eggs, garlic, ginger, herbs, ice, mushrooms, nuts, olives, onions, shallots, tomatoes, vegetables.	Place ingredients into Processing Bowl and process until the desired consistency is reached.
Puréeing	Processing Bowl fitted with Processing Blade.	Fresh, cooked or tinned fruits (such as apples, avocado, banana, peaches, pears, strawberries). Fresh, cooked or tinned vegetables (such as carrots, corn, peas, potatoes, pumpkin, tomatoes), peanuts for peanut butter.	Place ingredients into Processing Bowl and process until smooth.
Mincing	Processing Bowl fitted with Processing Blade.	Chicken fillets (boned), fish fillets (boned), red meat bacon rashers.	Food Should be pre-cut into 5-10cm cubes. Place ingredients into Processing Bowl and process.
Blending	Processing Bowl fitted with Processing Blade.	Cream, dips, flavoured butters, salad dressings, sauces, spreads, milkshakes.	Place ingredients into Processing Bowl and process until smooth. Put pressure on the Cover by placing your hand over and pressing down firmly. This will prevent spillage. (Additional liquid ingredients may be added through the Pouring Hole).
Crumbing	Processing Bowl fitted with Processing Blade.	Biscuits, bread, crackers, vanilla wafers.	Place pieces of food into the Processing Bowl and process until desired consistency is reached.

Oskar 400 Food Processing Guide (con't).

Processing Task	Attachment & Accessory	Food Product	Processing Procedure to be used
Mixing	Processing Bowl fitted with Processing Blade.	Melt & Mix Cakes and Packet Cake Mixes.	Place dry ingredients into the Processing bowl and process adding liquid ingredients through the Pouring Hole. When making fruit cake, fruit should be added later when mixture is combined.
		Batters.	Place dry ingredients into Processing bowl and process, adding liquid ingredients through the Pouring Hole.
		Shortcrust Pastry, Scones and Muffins.	Place flour and pieces of butter or margarine into Processing Bowl and process until mixture resembles breadcrumbs. Add liquid through the Pouring Hole.
		Yeast Doughs.	Place dry ingredients into Processing bowl and process until mixture forms a ball.
Shredding	Continuous Flow Attachment fitted with Shredding Disc	Apples, cheeses - (Cheddar, Romano, Mozzarella, Swiss, Parmesan), cabbage, carrots, chocolate, onions, potatoes, zucchini.	Pack food into the Feed Tube and using firm pressure press food down Feed Tube using the Food Pusher (NEVER USE YOUR FINGERS).
Slicing	Continuous Flow Attachment fitted with Shredding Disc	Fruits (such as apples, bananas, lemons, limes, melons, oranges, peaches, pears, pineapples, strawberries) vegetables (such as beetroot, cabbage, capsicum, carrot, celery, cucumbers, eggplant, lettuce, mushrooms, onions, radishes, parsnips, potatoes, tomatoes, zucchini), chicken, meat, salami.	Large foods should be cut to fit the Feed Tube. Pack food into feed Tube ensuring each piece of food supports another to give even slicing results. Note: Use light pressure on Food Pusher for thinner slices. Use firm pressure for thicker slices. meat and chicken should be partly frozen before slicing.

Trouble Shooting Guide.

Problem	Solution
Food is being unevenly processed or the Oskar moves across the work surface/benchttop.	You are overloading the Processing Bowl. Next time, process this amount in two or more batches.
The Oskar vibrates unnaturally or there are signs of the Processing Blade or Slicing/Shredding Disc hitting against either the Processing Bowl or Cover while the Oskar is operating.	The Processing Blade or Slicing/Shredding Disc has not been assembled properly. Stop the Oskar immediately and refit the cutting tool properly.
After processing, pieces of food are left on top of the Slicing/Shredding Disc.	Small pieces of food left on top of the Slicing/Shredding Disc is a normal occurrence.
Cover does not move freely when attached to the Processing Bowl.	Use a small amount of vegetable oil to lubricate the edges of the Processing Bowl and Cover.
Food falls over in the Food Tube during slicing	Pack the Feed Tube snugly and apply even pressure to the food being sliced

Recipes.

Basil and Almond Pesto *Makes: 1 cup*

Prep time: 5 minutes

- 1 cup basil leaves, preferably Greek*
- 1 birds eye chilli, seeds removed (optional)*
- ¹/₄ cup grated Parmesan cheese*
- ¹/₄ cup almond kernels*
- ¹/₃ cup extra virgin olive oil*

1. Place all ingredients except the olive oil into the processing bowl. Process for 5 seconds.
2. Gradually add the oil through the hole in the processing cover and process for another few seconds. Scrape into a jar and store in the fridge.

Note: Will keep in the refrigerator for 3 days.

Yoghurt and Herb Chicken

Prep time: 10 minutes

- 2 BBQ chicken breasts (buy a BBQ chicken and shred the breast flesh)*
- ¹/₂ cup traditional yoghurt*
- A few Greek basil leaves, opal (purple) basil leaves and parsley leaves (approx ¹/₄ of mixed herbs leaves)*
- Pinch freshly grinded sea salt and peppercorn melody*

1. In the processing bowl combine the yoghurt, mixed herb leaves and seasonings. Process for 5 seconds.
2. Place shredded chicken in a dish. Pour the processed mixture over the top of the shredded chicken and toss.

Serving Tip: Serve with salads, as filler for an entree, on sandwiches, great with fruit chutney, cheese and crackers.

Fresh Prawn Cakes *Makes approximately 8.*

- 200g prawn meat*
- 8 garlic chives stalks*
- 6 Vietnamese mint leaves*
- 1 egg white*
- Seasoned flour (¹/₄ cup plain flour with ground sea salt and mixed peppercorns)*

1. In the processing bowl combine the prawns, chives and mint. Process for 5-10 seconds until fine.
2. Using a tablespoon measurer, scoop out tablespoons of the mixture and place into a bowl of seasoned flour. Then roll each tablespoon of mixture into a ball.
3. Immediately place into a pan of hot oil and cook until golden brown and the cake springs back when touched with the back of the tongs and the flesh has turned opaque (white).

Serving Tip: Serve immediately. If desired serve with lemon or lime wedges and freshly ground sea salt.

Balti Lamb Curry with Couscous *Serves 4*

Prep time: 10 minutes

Cooking time 1hour 30 minutes

- 1 onion, peeled and quartered*
- 3 cloves garlic, peeled*
- 2 tablespoons olive oil*
- 600g lamb leg steaks, cut into cubes*
- ¹/₂ jar Balti paste (approx. 4 tablespoons)*
- 1 punnet cherry tomatoes*
- 1 x 440g can whole peeled tomatoes in natural juice, undrained*
- 1 x 440g can chick peas in juice, undrained*
- 1 cup fresh or frozen peas*
- 400mls water*
- Couscous*

1. Process the onions and garlic until finely chopped.
2. Heat oil in a heavy based stockpot or saucepan. Add the onions and garlic and cook over a low heat until onions are soft and golden. Turn up the heat slightly and add the meat. Cook until well browned.

Recipes.

3. Reduce heat and add the balti paste cook until fragrant. Turn up the heat slightly again and add the cherry tomatoes, whole peeled tomatoes, and cook for a few minutes. Add the chick peas, peas and 400mls of water. Bring to the boil and reduce to a simmer. cook covered for 1 hour. Stirring occasionally.
4. After an hour, taste to see if meat is tender, if not keep covered and cook for a further 15-20 minutes. When meat is very tender and falls apart when pricked with a fork, remove the lid and cook uncovered for 5 minutes. Stirring occasionally.
5. Remove from heat allow to stand for 5 minutes before serving. Serve in large bowls with spoonfuls of buttered couscous.
6. Buttered couscous. Follow packet instructions and just before serving fork through knobs of soft butter to taste.

Soy, Honey and Ginger Chicken Wings Serves 4

Prep time 5 minutes

Cooling time 30 minutes

Marinating time: overnight

Marinade:

3 cloves garlic, peeled

4cm piece green ginger, peeled and grated

1/2 cup soy sauce

1/2 cup extra virgin olive oil

3/4 cup honey

1/2 teaspoon Chinese 5 spice powder

Salt and pepper

12 meaty chicken wings, cut each wing at the joints (optional)

2 Tablespoons sesame seeds

1. In the processing bowl add all of the marinade ingredients and process together for 5 seconds until well combined. Pour the marinade into a large snap lock bag.
2. Place the chicken wings and sesame seeds into the bag and shake well, ensuring that all the chicken wings are coated with the marinade. Leave to marinate in the fridge over night. Turn the bag over once during the night.
3. The next day pour the contents of the bag into a baking dish (lined with baking paper) and bake the wings at 180°C for approximately 25-30 minutes or until the chicken wings are a dark golden colour, but not burnt. Keep brushing the chicken with the marinade during cooking.

Serving Tip: Serve immediately with rice and Asian greens. Wings can also be served cold. Great cold at a picnic or as an entree at a summer dinner party.

Avocado Spread

Makes 1 cup

Prep time: 5 minutes

No cooking required

1 avocado, peeled and flesh removed

1/2 cup sour cream

Salt and pepper to taste

1/4 teaspoon crushed hot chilli paste

1. Process all ingredients together in the processing bowl until smooth and creamy.
2. Serve chilled with an assortment of breads.

Recipes.

Salsa Verde

Makes approx 1 cup

Prep time: 5 minutes

Cooking time nil

1 cup mixed herb leaves (sage, rosemary, basil, and continental parsley)

¹/₂ tablespoon salted capers, soaked washed and drained

1 tablespoon mustard

2 cloves garlic, peeled

1 tablespoon vinegar (white wine or white balsamic)

¹/₂ cup extra virgin olive oil

¹/₄ cup lemon juice

Salt and pepper to taste

1. Process all ingredients in the processing bowl for 5 -10 seconds.
2. Store in a jar for 3 days.

Note: Use as an accompaniment with seafood or pasta dishes.

Yoghurt, Parsley, and Tahini Spread

1 cup continental parsley leaves

2 green onion (shallot)

1 slice white bread soaked in 1 tablespoon milk

¹/₂ cup thick natural yoghurt

¹/₄ cup tahini

2 tablespoons extra virgin olive oil

1 tablespoon lemon juice

1 tablespoon pinenuts toasted

1. Process all ingredients in the processing bowl until well combined, smooth and creamy.
2. Serve with extra pinenuts and drizzle with extra virgin olive oil.

Serving Tip: Serve with pita bread, hot naan or lavish bread.

Herb and Capers Butter

200g butter, chopped and softened to room temperature

6 anchovy fillets

1 tablespoon salted capers, soaked, rinsed and drained

¹/₂ cup lemon juice

¹/₄ cup cont. parsley leaves

2 tablespoons sunflower oil

1. Process all ingredients in the processing bowl until well blended, do not over blend, as butter will split.
2. Scoop out mixture onto a sheet of foil lined with cling wrap. Bring the two short sides together in the middle. Press together and fold down toward the butter. Pinch the other two sides together and twist encasing the butter. Gently roll into a firm sausage shape. Freeze or refrigerate until required.
3. Cut into 1cm slices.

Serving Tip: Serve with prime cuts of beef or lamb and a creamy potato mash or serve at your dinner party with warmed bread.

Recipes.

Olive Oil Mayonnaise

Makes approx. 1 cup

Prep time: 5 minutes

Cooking time nil

2 egg yolks

2 teaspoons white vinegar

Freshly ground sea salt

Coarsely ground black pepper

$\frac{1}{4}$ teaspoon mustard

75mls good quality extra virgin olive oil

175mls sunflower or vegetable oil

1. Place yolks, vinegar, mustard and seasoning s into the processing bowl. Commence processing while gradually pouring the oil through the hole in the processing cover. Process until mixture becomes very thick and creamy.
2. Add 1 teaspoon boiling water and process for a second or until well combined. Mixture should be very thick and creamy.
3. Taste and add extra salt and pepper if necessary.
4. Store mayonnaise in a jar. Keep's well for up to 2 days, stored in the refrigerator.

Laska Paste

Makes: 1 cup

Prep time: 5 minutes

Cooking time: nil

2 small white onions, peeled and quartered

4cm piece ginger, peeled and sliced

8 cloves garlic, peeled

6 bird eye chillies (seeds removed- optional)

2cm piece fresh turmeric, peeled and grated or use 1 Tablespoon powdered turmeric

1 lemongrass stalk crushed and roughly sliced or use 2 tablespoons of jar variety with vinegar, drained

$\frac{1}{2}$ cup peanut or vegetable oil

1. Process all ingredients in the processing bowl until the mixture is smooth.
2. Store the paste in a jar for 2-3 days.

Note: Ensure to cook the paste until fragrant before adding coconut milk when making a laksa.

Hazelnut, Choc and Coffee Biscuits

Makes: 40

Prep time: 5 minutes

Cooking time: 20 minutes

125g toasted hazelnuts

2 tablespoons cocoa

1 tablespoon plain flour

1 tablespoon instant coffee

1 egg white

110g caster sugar

Raw sugar, to sprinkle

Note: With this recipe use heaped tablespoon measure.

1. In the processing bowl, process the hazelnuts, cocoa, flour and coffee until a fine powder. Mixture should be dry and rich in aroma and colour.
2. Using Sunbeam electric beaters beat egg whites until soft peaks are formed. Gradually add sugar, beating well after each addition of sugar until sugar is dissolved and mixture is thick and glossy. Fold in hazelnut mixture with a rubber spatula until all is well combined. Mixture will be dry and stiff but should hold a firm ball. It will be sticky.
3. With wet hands, roll teaspoon size balls and place 2cm apart on a tray lined with baking paper. Flatten each ball slightly with a fork.
4. Sprinkle with raw sugar and bake at 150°C for 15-20 minutes. Cool on a wire rack.

Serving Tip: Best dipped into a freshly brewed coffee.