



# XR-800 / XR-1200

## Operating Guide

### WARNING

TO PREVENT ELECTRICAL SHOCK  
OR FIRE HAZARD, DO NOT EXPOSE  
THIS APPLIANCE TO RAIN OR

MOISTURE. BEFORE USING THIS  
APPLIANCE, READ THE BACK  
COVER FOR FURTHER WARNINGS.

### GENERAL DESCRIPTION

Today's sound reinforcement requirements have evolved over the years as musical styles, sound pressure level requirements, and advances in technology interrelated. For years, PA systems were simple mixer/power amps until performers and audiences demanded state-of-the-art performance that required separate mixer/power amps. Up until very recently, extremely high quality mixers with integrated power amps were not technically and/or economically feasible. Peavey, one of the world's foremost producers of sound reinforcement equipment, has developed a comprehensive range of new components, packaging techniques, special circuitry, transformers, and connectors to make the production of an integrated state-of-the-art system technically and economically feasible for the first time.

The new XR-800/XR-1200 Powered Mixing Console offers the most flexibility to ever be featured in one compact package. The system includes stereo (dual channel) output with dual Sub Master assignment capability mixing into a sum control which allows for monaural operation. Aside from the normal stereo mixing situation, the XR-800/XR-1200 offers additional features such as two 9-band graphic equalizers, two 200 watt power amplifiers, two separate monitor mixes (A & B), PFL (pre fade listen), normal stereo headphone system, one effects system, built-in reverb, DDT™ compression on each power amp, and pre send and return on each channel. The XR-1200 features twelve low impedance mic level inputs and twelve high impedance inputs, ten-segment LED level indicators for A & B mains and monitors A & B, and also a complete patch panel at the back of the system for patching out to other systems and for bringing other signals into the master section of this system. The XR-800 includes identical features listed above except there are only eight channels with eight mic inputs and eight line level inputs.

## TYPICAL CHANNEL INPUT GAIN CONTROL

The input gain control will allow input signals of tremendously varying sensitivities to be optimized for sound reinforcement or recording. This control should be adjusted with the highest expected input level for a particular channel with the channel level slider operated near the center of its range. The input gain control is critical to the operation of the mixer and should be set according to the voice or instrument that is feeding a particular channel so that the job of mixing may be accomplished with the proper amount of headroom and signal-to-noise being established with this first control. Once the input gain is properly adjusted, gain should be regulated at the channel output slider. Since the monitor send and all other channel functions are affected by the input gain control, it is not wise to attempt gain regulation with this control during a concert performance.

## MONITOR SENDS

The two monitor send controls (A & B) may be used for two totally separate monitor mixes. Turning up these controls will send signals to the A & B monitor master controls which will establish the monitor mixes for a stage or sound reinforcement situation. Monitor sends A & B are pre fader and pre EQ and may be used for cueing while recording, if necessary.

## THREE-BAND EQUALIZATION

The three bands of equalization on each channel are active controls and feature a "0" indication at the 12:00 o'clock setting which indicates flat frequency response. These controls are labeled "LOW," "MID," and "HIGH." The low equalizer yields +15 dB @ 60 Hz (shelving). The mid equalizer yields +15 dB @ 600 Hz (peak/notch). The high equalizer yields +15 dB @ 8 KHz (shelving).

## EFFECTS SEND CONTROL

The effects send control is post EQ and post fader and is used to set the amount of internal reverberation that is desired for each channel. This control is also used to send a signal from each channel by way of the effects output (on the rear panel) to external effects devices which may be patched into the system.

## PAN CONTROL

The pan control is post fader and gives the option of sending the channel output to main A or main B or both. This control can be used as a typical pan control for stereo imaging or as a "channel assignment" control for doing sound reinforcement. By running the main system in mono with the sum master output for the house, A and B mains as submasters, the operator has much more flexibility for handling various types of program material. It is generally not good practice to operate the sound reinforcement system in stereo unless the operator is an accomplished mix engineer who understands that stereo to the audience is complicated business which may degrade the overall performance.

## CHANNEL LEVEL SLIDER

The channel level slider is the output control which feeds through the pan control and into the main summing busses. This control determines the overall level of the mix established at each channel that will appear at either main A or main B or both in the master section. Whenever possible, this control should be operated near the mid point of its travel for maximum headroom and optimum signal-to-noise performance.

## MASTER SECTION

As the name implies, the master section of the XR-800™/XR-1200™ contains all master control functions which control the final mix of all channel send controls and regulate the final levels to the graphic equalizers and internal power amplifiers. These master controls allow the operator complete flexibility for all functions and should allow almost any mixing situation to be handled. As with any reasonably complex system, experience and operator knowledge of the equipment are essential for satisfactory performance. The mixer, like a musician's instrument, should be practiced on and learned. To properly operate a mixer during a performance requires thorough knowledge and training of reflexes to allow proper responses under the stress of demanding and sometimes sudden situations.

## SUM

The sum control is the combination (summing) of signals from both A & B mains and is designed to give the operator monaural capability. In the case of channel assignment being accomplished by the pan controls on each channel and certain instruments grouped to the A master and other instruments or vocals grouped to the B master, the sum control would then be your house level control. Patch facilities on the rear panel of the XR-800™/XR-1200™ will allow the sum output to be patched back into either graphic or internal power amplifier when accomplishing a monaural system with two submasters. (See patch diagrams for hookup.)

NOTE: For stereo or when two-channel output is desired, the sum slider is normally not used.

## EFFECTS TO MONITOR A CONTROL

This control enables the effects return from external effects devices to be blended into the Mon. A. mix. (Output from delay units, flangers, phasors, etc. that may be patched into effects loop.)

## EFFECTS LEVEL CONTROL

The effects level control regulates the amount of signal from the effects return input that feeds the effects pan control.

## EFFECTS PAN CONTROL

The effects pan control is post the effects level control and allows blending of the effects return into A or B mains or both.

## MONITOR A & B

The monitor A & B master controls are rotary types and are located just above the main A & B sliders. These controls are the master output levels for both monitor buses (A & B) with each buss being totally independent of the other. The monitor A & B feature of the XR-800™/XR-1200™ allows for two totally separate monitor mixes for stage or sound reinforcement purposes. These controls are conventional in operation and should present no problem to the operator. For optimum signal-to-noise and headroom performance, once again, these controls should be operated near the midpoint of their range. The signal from monitor A & B master controls appears at the monitor A & B outputs on the rear patch panel.

## MAIN FADERS A & B

The main faders A & B are the main output sliders and control the overall signal levels from each channel supplied to the main (A & B) output jacks on the rear panel and ultimately to the graphic equalizers and the internal power amplifiers. Again, under normal usage, these controls should be operated near the center range to allow optimum performance. (Settings above center increase.)

## REVERB TO MONITOR A CONTROL

The XR-800™/XR-1200™s unique circuitry allows blending of reverberation back into the monitor A mixing bus for those who do not prefer a dry monitor sound. Caution should be exercised when using this control because too much reverberation added to the monitor mix could cause undesirable feedback.

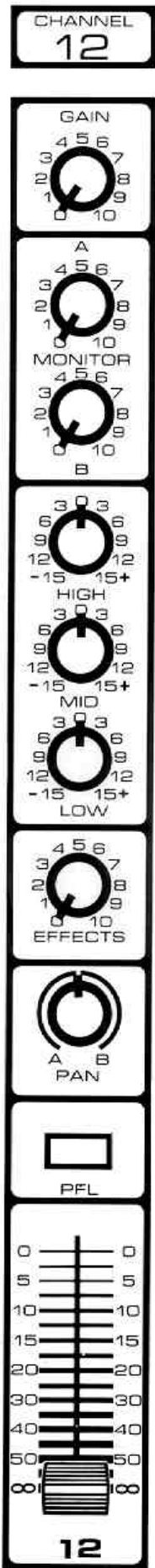

### REVERB LEVEL CONTROL

The reverb level control determines the amount of delayed (reverb) signal which feeds the reverb pan control.

### REVERB PAN CONTROL

The reverb pan control is post the reverb level control and allows blending of the delayed (reverb) signal into A or B mains or both.

### REVERB TO MONITOR B CONTROL

This control works exactly like the "reverb to monitor A" control except that it blends reverberation into monitor B. Please note that both effects and reverb may be blended into monitor A while only reverb may be blended into monitor B.

NOTE: When mixing reverb into monitor A or monitor B the operator must be aware that the effects send control on each channel is post fader and will not send reverb signal unless channel fader is activated.

### EFFECTS MASTER CONTROL

The effects master control is the final control element determining the output level from the effects send on each channel to the effects output jacks on the rear panels. At the same time, this control also determines the amount of signal that is delivered to the internal reverberation system. Please note that no reverberation effect may be achieved unless the individual channel effects send controls, effects master level control, channel slider, and the reverb master are adjusted properly.

### PFL LEVEL CONTROL

The PFL level control determines the overall signal which is summed from all PFL channel sources and overrides the normal headphone level. This control should be adjusted for the amount of "pre fade listen" that is necessary for each situation depending on sound pressure level that is being produced for a given concert situation, and quality/efficiency of the headphones employed.

### HEADPHONE LEVEL

This control determines the headphone level and is completely independent of the PFL level control. When a normal headphone is employed in the headphone jack on the front panel of this system, and no PFL buttons are depressed, the electronics logic circuit allows monitoring of monitors A & B. From this situation, the A & B main busses or individual channels may be monitored through the headphones by use of the PFL level control and PFL channel functions.

NOTE: PFL functions override normal headphone listening capability.

### HEADPHONE JACK

Headphone jack is a stereo type (ring, tip, and sleeve) which is standard on most stereo headphones. The internal headphone amplifier will drive most normal dynamic low to medium impedance headphones and should work with most ceramic or crystal units as well. Please note that this output jack is stereo with the two output terminals connected for mono operation through stereo phones.

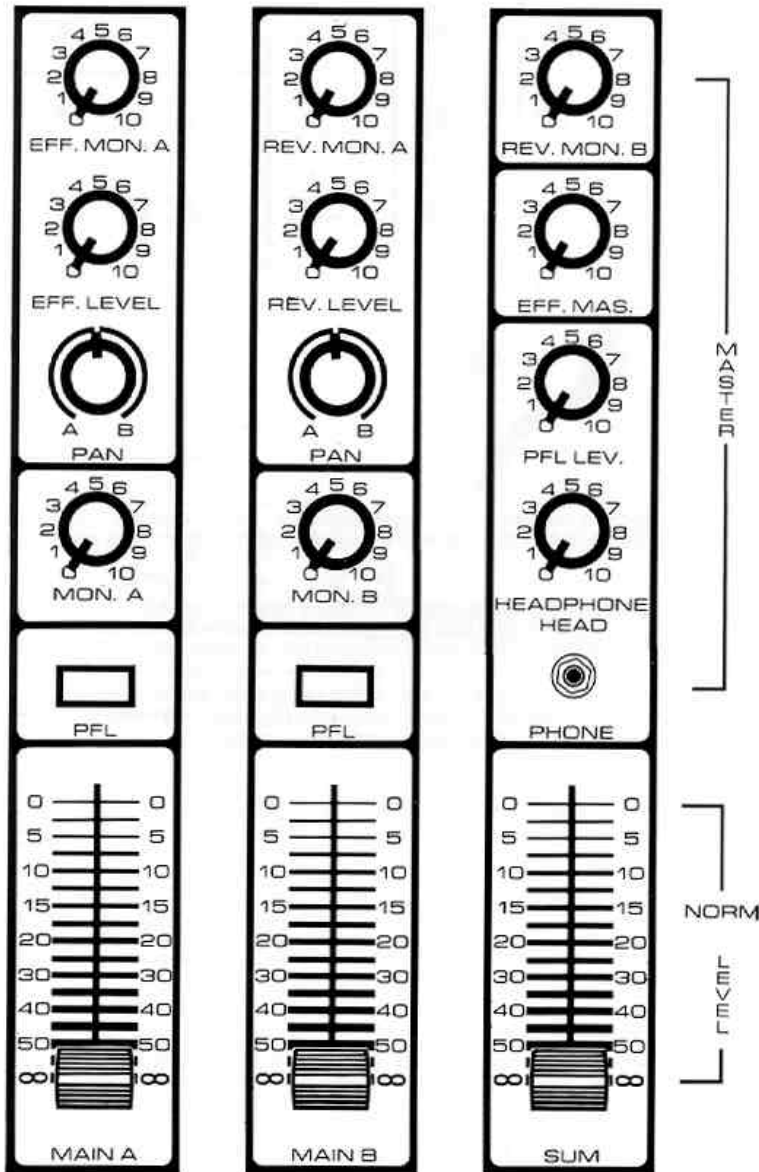

### GRAPHIC EQUALIZERS

The XR-800™/XR-1200™ includes two 9-band equalizers which are active and exhibit top quality performance comparable to that found in the finest professional equipment. One graphic equalizer is provided for each main (A & B) and appear in the audio chain immediately after the master A & B sliders and before the power amps A & B. Graphic inputs and outputs for each system are provided on the back panel. (See hook-up diagrams for additional patching capability.) These 9-band graphic equalizers are excellent units for tone coloration, room equalization, and effective feedback control. However, it is important to note that 9-bands of EQ will only effectively suppress two or three feedback problems. If feedback is a real problem in a given room it is wise to add more equalization, possibly in the form of a 1/3 octave equalizer.

### DDT™ COMPRESSION

The XR-800/XR-1200 is equipped with our DDT™ (Distortion Detection Technique) Compression Circuitry (U.S. Patent #4,318,053) that senses conditions which might overload and activates compression when clipping is imminent. In other words, compression takes place whenever signal conditions exist which prevent the amplifiers from faithfully reproducing the input signal. The threshold of this compressor is the clipping level itself and no specific threshold control is provided. This technique effectively utilizes every precious watt available from the power amps. Because of the dynamics of music and vocal program material it is quite common to activate the compression circuitry virtually constantly during the performance since this is what it is designed to do. This system will maximize the dynamics available from the amplifiers within their power output capabilities regardless of power supply/line mains voltage variations and load impedance selection.

### NOTE:

THE XR-1200 ONLY INCLUDES TOGGLE SWITCHES TO DEFEAT THE COMPRESSION CIRCUIT. THE SWITCHES SHOULD BE PLACED AT THE IN POSITION FOR MOST CIRCUMSTANCES OF NORMAL OPERATION. LED INDICATION WILL FLASH WHEN COMPRESSION TAKES PLACE. THE XR-800 DOES NOT INCLUDE TOGGLE SWITCHES AND COMPRESSION IS EMPLOYED FULL TIME.

### PILOT LED

The Pilot LED indicates when the electrical supply is switched on and is actually delivering power to the amplifier.



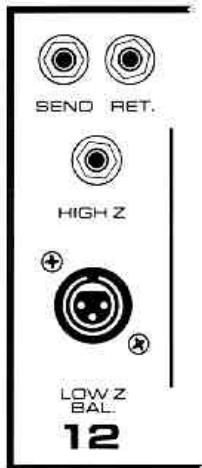

**REAR PANEL  
INPUT TYPICAL CHANNEL**

Each channel of the XR-800™/XR-1200™ features both balanced (symmetrical) low impedance 600 ohms (as well as high impedance 50K ohms) unbalanced input. Each of these inputs feature extremely wide dynamic range and are fully transient protected to insure durability for road conditions. Each channel also features a send and return jack which provides an effects loop for each channel. The send jack is used to patch out of the system and presents the single output from the input preamp. The signal that is available at this point is approximately 1 volt RMS at an output impedance of approximately 600 ohms and is pre EQ and immediately after the input gain control. The return jack presents a relatively high impedance (50,000 ohms) to minimize loading with external devices and should work well with any device capable of delivering single levels of at least 1 volt to this impedance. This jack is of the switching type and allows the return signal to be patched back into the system immediately after the input gain control and pre the EQ. The return jack provides the completion of the effects loop that is normally used for patching in various auxiliary devices such as effects units, phasers, etc. in line with each individual channel preamp. Be careful when attempting to patch in devices to this system and be sure units that are capable of line levels are used for this feature.

**OUTPUT SECTION**

Preamp outputs are featured on the back panel for mains A & B, monitors A & B, and the sum. Two phone jacks are provided at each one of these outputs for convenience and are fully transient and short circuit protected for maximum field reliability when patching systems together. The output level presented by these jacks is controlled by the settings of the related master level controls on the front panel and are capable of more than 8 volts RMS output into a 50,000 ohm load impedance.

**EFFECTS OUTPUT**

The effects output presents the signal from the effects mixing buss. This jack is a unique two-position type with the first position being a low level output and the second position being the high level output. This unique arrangement enables use of this mixer with either the line level or instrument level effects devices, depending on which click of the jack is used. The overall output level from the effects jack is determined by the setting of the master effects level control on the front panel.

**GRAPHIC INPUTS AND OUTPUTS**

Each graphic of the XR-800™/XR-1200™ has been equipped with patching jacks, both at the input and the output to allow patching either graphic elsewhere in the system. Graphic inputs are of relatively high impedance type (50,000 ohms) and require approximately a one volt RMS nominal level. The graphic outputs are low in impedance, type 600 ohms. Graphic inputs are of the switching type and allow the graphic to be switched away from its normal connection with A or B mains in order to accept an external signal that needs to be equalized. Typical use of this graphic input, for instance, would be if a graphic is used to equalize the monitor system. (See patch diagrams for hook-ups.)

**POWER AMP INPUTS**

Each power amp in the XR-800™/XR-1200™ features an input jack to facilitate patching in other signals. The power amp input jacks are of the switching type that break the circuit which is normally connected to the output of the graphic equalizers. Whenever plugs are inserted into the power amp inputs, all connections to previous circuitry in the unit are broken and the power amp input jacks effectively become the input for the internal power amplifiers. This unique feature allows either of the power amplifiers to be patched separately as needed within the system. (See patch diagrams for hook-ups.)

**REVERB FOOTSWITCH**

To facilitate remote control of the reverberation function, we have included a remote control footswitch jack. Any standard single pole footswitch may be used to remotely defeat the reverb function. Please note that this switch disables the reverb system only, and has no effect whatsoever on the effects system.

**EFFECT RETURN**

The effects return input on the rear panel may be considered an auxiliary input for the effects system. The effects return is capable of handling a wide range of input signals and is the normal input which is used for completing the effects loop that may be patched into one of the effects output jacks. The effects return system feeds through the effects pan control into A or B mains, or both, and is intended for use when returning external devices that should be mixed into the main mixing busses.

**SUM INPUT**

The sum input jack is the input to the sum main slider and is of the switching type, which is normally connected to a sum mix of the two main channels. Any signal which is patched into the sum input will totally bypass mains A & B and the master section and go directly to the sum fader, located on the front panel.

**AUXILIARY INPUTS**

Auxiliary inputs are provided at line levels for access into all five internal mixing busses. (Main A, main B, monitor A, monitor B, and effects.) They are the medium impedance type (33,000 ohms) and are provided to allow paralleling mixers, or for any other purposes that require direct signal injection into all mixing busses.

**POWER AMP OUTPUT (SPEAKERS)**

The power amp output jacks are provided as a means of connecting speaker systems to the internal 200-watt power amps. Each power amp has two output jacks which are wired in parallel. The internal amplifiers are designed for a four ohm total load and will supply maximum power into this impedance. Different impedances may be used with the internal amplifiers with some sacrifice in output power. Caution should be observed in using lower than 4-ohm total load, since this tends to increase the heat build-up, as well as enhancing possibility of energizing the power amplifiers internal short circuit and/or thermal overload protection system.

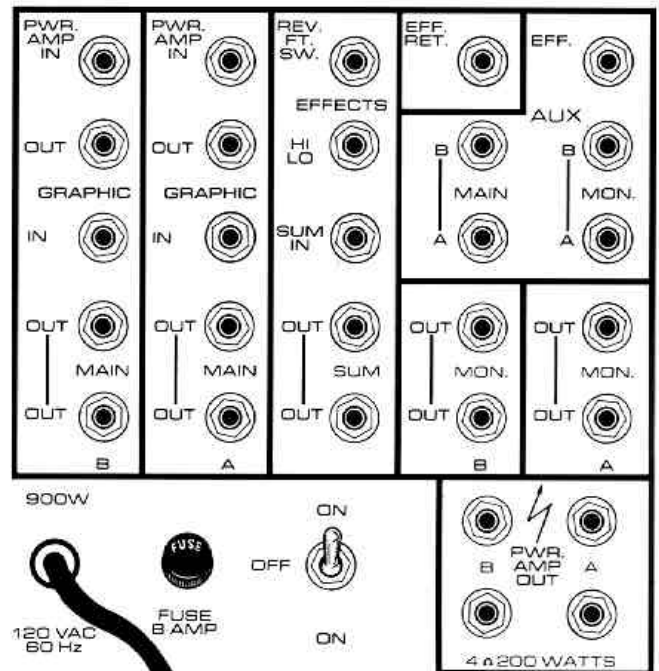

**CAUTION:**

**TO INSURE MAXIMUM POWER, INTERFACE SPEAKER CABLING SHOULD BE KEPT AS SHORT AS POSSIBLE AND THE LARGEST PRACTICAL WIRE SIZE SHOULD ALWAYS BE USED. HIGH LEVEL AMPLIFIERS GENERATE EXTREMELY HIGH CURRENTS WHICH ARE GREATLY AFFECTED BY THE RESISTANCE OF THE SPEAKER CONNECTION WIRING. IT IS VITAL THAT THE WIRE GAUGE OF THE SPEAKER CONNECTION WIRES BE AS LARGE AS PRACTICAL AND THE LENGTH OF THE CONNECTING CABLES BE REASONABLY SHORT. SIGNIFICANT SACRIFICES IN PERFORMANCE WILL RESULT WITH SMALLER WIRES AND/OR LONG SPEAKER CABLE RUNS.**

**CAUTION:**  
**UNDER NO CIRCUMSTANCES IS IT RECOMMENDED THAT THE POWER AMPLIFIERS IN THIS POWERED MIXING SYSTEM BE USED WITH EXTREMELY LONG SPEAKER CABLES, OR WITH SNAKE INPUT/OUTPUT MULTI-CABLES.**

**FUSE**

The Fuse is located within the cap of the fuseholder. It is necessary that the Fuse be replaced with the proper type and rating so that if it should fail to avoid damage to the equipment and to prevent voiding the warranty. If your unit repeatedly blows fuses, it should be taken to a qualified service center for repair.

**POWER SWITCH**

On domestic units the power switches are of the three-position type with the center position being off. This switch has two On positions, one of which is used to ground the amplifier properly. One of the On positions will yield the lowest amount of residual hum or popping when the instrument is touched and this is the position that should be used. On export models we utilize a simple On/Off switch that does not have multiple On positions, since the grounding conditions in most other countries are positively made through the standard tamper-proof plug-in systems.

**LINE CORD**

For your safety, we have incorporated a three-wire Line Mains Cable with proper grounding facilities. It is not advisable to remove the ground pin under any conditions. If it is necessary to use the amp in a two-pin plug system without proper grounding facilities, suitable grounding adaptors should be used. Much less noise and greatly reduced shock hazard exists when a unit is operated with the proper grounded receptacles. **WARNING:** To prevent electrical shock or fire hazard do not expose this appliance to rain or moisture.

**SET UP PROCEDURE:**

**I. MAIN SYSTEM:**

- A. With all Input Gain Controls at 0 or fully counterclockwise, adjust Channel and Master Sliders to approximate mid point of travel.
- B. Adjust Equalizer Controls on each channel for 0 position or flat response until room acoustics have been sampled. Then adjust EQ for personal tastes, tone coloration, and/or feedback suppression.
- C. Adjust Input Gain for each voice or instrument as described in this manual (see the Input Gain Control section).
- D. If reverberation is desired, adjust Channel Effects Sends, Master Effects and Reverb Master Level for amount of reverb to satisfy personal tastes. **NOTE:** See hookup diagrams for additional patching flexibility (operating system in mono, etc.).

**II. MONITOR SYSTEM:**

- A. Patch from Monitor A Output at rear panel to input of the power amp/speaker system designated for monitor. **NOTE:** If Graphic EQ is desired for the monitor mix, this unit must be interfaced between the Monitor Output and the Monitor Power Amp. All patch connections should be made with shielded cords.
- B. With Input Gain Controls already set for main system, adjust Monitor Master Controls to the approximate mid point of rotation.
- C. Select amount of Monitor Send desired from each channel by adjusting Monitor Sends A or B.
- D. If two separate monitor mixes are desired, repeat steps A through C above with a second monitor amplification system using Monitor B Controls and Outputs. **NOTE:** It is important that the monitor system be initially adjusted with the mains system adjusted and active as there is a definite interaction between the two.

**STOCK SET-UP — NO PATCHING — STEREO**

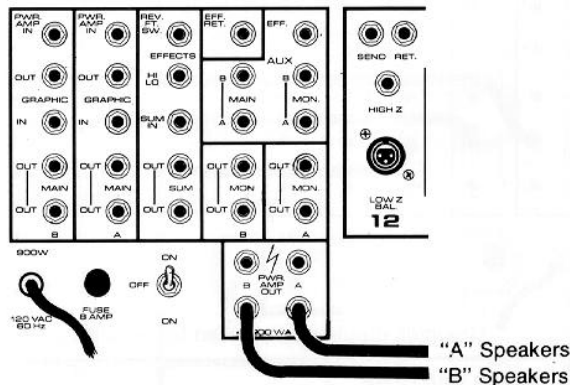

**MONO OPERATION WITH ONE GRAPHIC/PWR. AMP FOR MAINS AND ONE GRAPHIC/PWR. AMP FOR MONITOR**

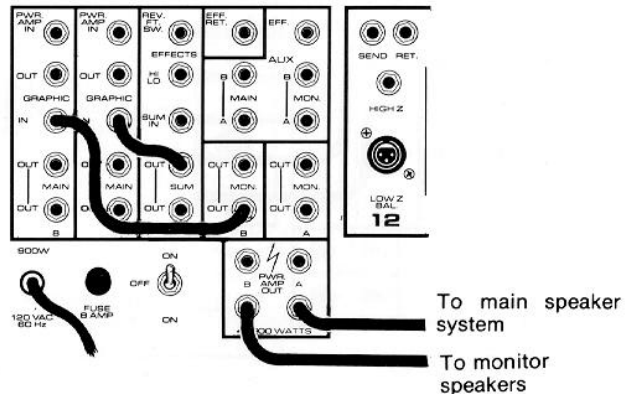

**MONO OPERATION WITH BOTH MAINS FEEDING GRAPHIC "A" AND BOTH POWER AMPS**

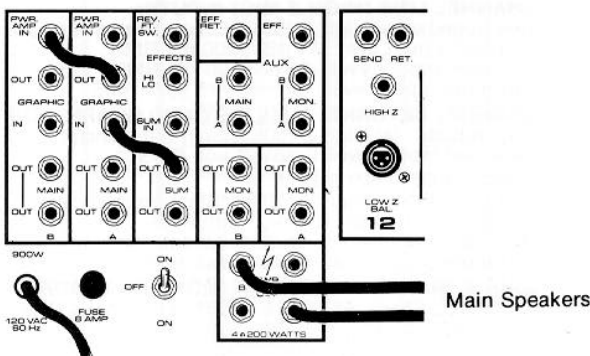

**TWO MONITOR MIXERS WITH INTERNAL AMPS AND GRAPHICS — SUM PATCHED TO ADDITIONAL POWER AMP FOR MAINS**

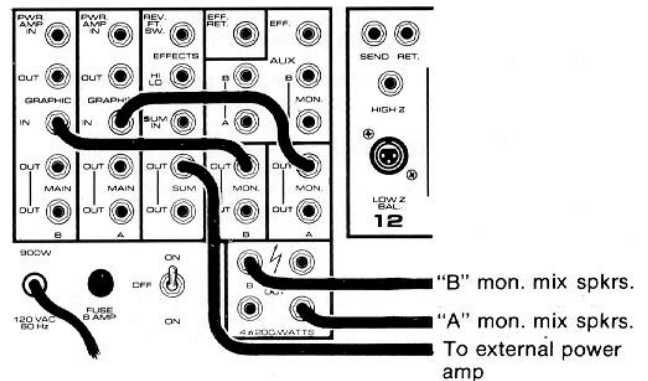

## BI-AMPLIFICATION WITH XR-1200™/XR-800™ AND ECM™ WITH PL-SP-1™ MODULE

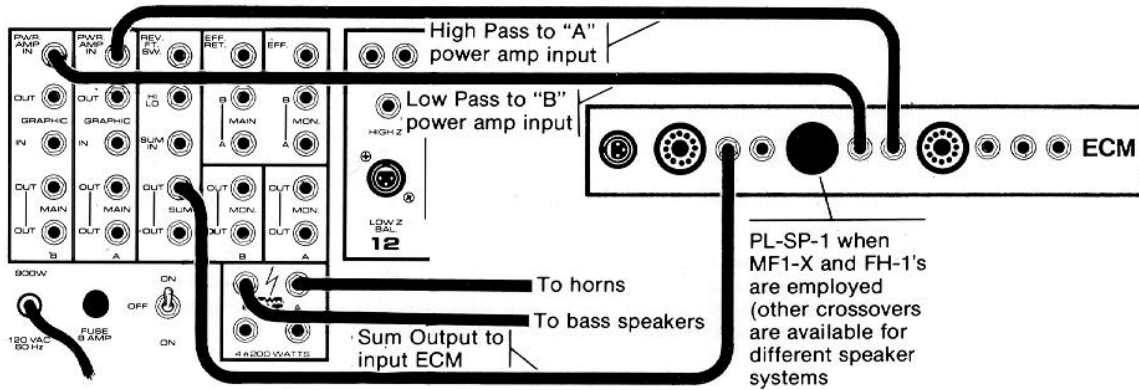

## EFFECTS LOOP PATCH

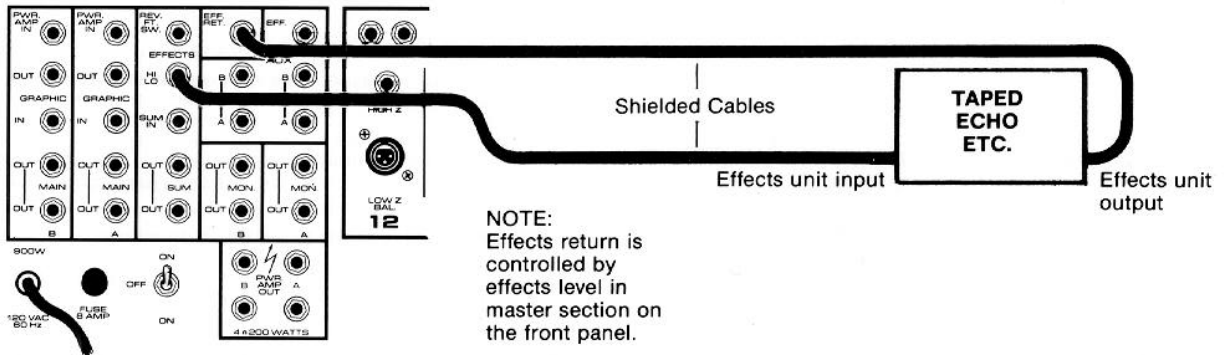

## PATCHING TWO XR-1200™/XR-800™ BOARDS TOGETHER

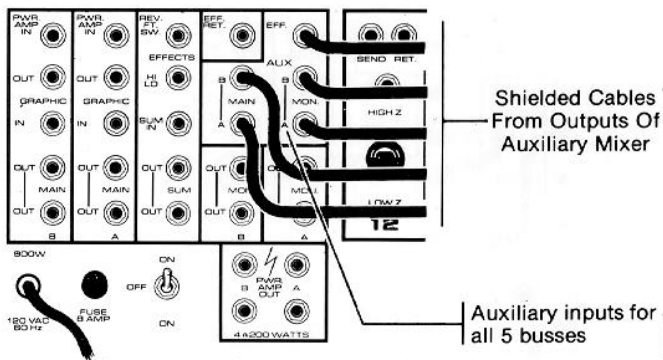

## TAPE RECORDING

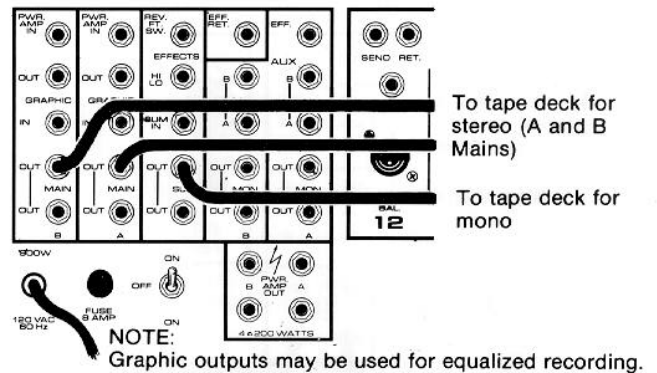

## XR-800™/XR-1200™ SPECS:

### Summary of Functions:

8 in (XR-800™), Stereo Main out, Sum out, 2 Pre Monitor out, Mono Headphone, 1 Post Effects out, 3-band EQ and PFL each channel, Reverb, 2 patchable 9-band Graphic Equalizers, 100 watts (XR-800™), 200 watts (XR-1200™) per channel stereo power amp with DDT

### INPUTS, EACH OF 8 CHANNELS (XR-800™);

### 12 CHANNELS (XR-1200™):

1 Low Z balanced mic, 1 High Z unbalanced line, and 1 High Z unbalanced return line.

### INPUTS, MASTER:

1 unbalanced auxiliary for Main A & B, Monitor A & B, Effects and Sum, 1 unbalanced High Z Effects Return, 1 High Z unbalanced line for each graphic and each power amp.

### OUTPUTS, EACH OF 8 CHANNELS (XR-800™);

### 12 CHANNELS (XR-1200™):

1 Low Z unbalanced send line

### OUTPUTS, MASTER:

1 Low Z unbalanced lines each for Main A, Main B, Monitor A, Monitor B and Sum, 1 High/Low Level Effects, 1 Low Z unbalanced line for each Graphic, Mono headphone with stereo jack, Reverb footswitch

### OUTPUTS, POWER AMPS:

2 parallel each channel, 4 ohm minimum parallel load

## MIXER SECTION:

### CHANNEL MICROPHONE INPUTS:

Mic Impedance: Low Z (600 ohms) balanced  
Nominal Input Level: -26 dBm, 40 mV RMS  
Minimum Input Level: -42 dBV, 6 mV RMS  
Maximum Input Level: +8 dBV, 2 volts RMS

### CHANNEL LINE (HIGH Z MIC) INPUTS:

Line Impedance: High Z (50K ohms) unbalanced  
Nominal Input Level: -14 dBV, 200 mV RMS  
Minimum Input Level: -30 dBV, 30 mV RMS  
Maximum Input Level: +20 dBV, 10 volts RMS

### CHANNEL RETURNS, AUXILIARY AND GRAPHIC INPUTS:

Line Impedance: High Z (50K ohms) unbalanced  
Designed Input Level: 0 dBV, 1 volt RMS

### EFFECTS RETURN INPUT:

Line Impedance: High Z (220K ohms) unbalanced  
Nominal Input Level: 0 dBV, 1 volt RMS  
Minimum Input Level: -14 dBV, 0.2 volt RMS  
Maximum Input Level: +6 dBV, 2 volts RMS

### MAIN A, MAIN B, MONITOR A, MONITOR B, SUM, CHANNEL SEND, EFFECTS HIGH LEVEL AND GRAPHIC UNBALANCED OUTPUTS:

Load Impedance: 600 ohms or greater  
Nominal Output: 0 dBV, 1 volt RMS  
Maximum Output: +18 dBV, 8 volts RMS into 50K ohm load  
Maximum Output: +14 dBm, 4 volts RMS into 600 ohm load

**EFFECTS LOW LEVEL UNBALANCED OUTPUT:**

Load Impedance: 10K ohms or greater  
Nominal Output: -12 dBV, 0.25 volt RMS  
Maximum Output: +6 dBV, 2 volts RMS

**HEADPHONES:** (Mono amp with stereo jack)

Load Impedance: 4 ohms to 50 ohms  
Maximum Output Power: 100 mW

**THE FOLLOWING SPECS MEASURED WITH A NOMINAL INPUT GAIN SETTING OF +14 dB ALL CHANNELS, ALL SLIDERS SET AT NORMAL, ALL EQ SET FLAT, LOW Z INPUTS TERMINATED @ 600 OHMS, HIGH Z INPUTS AND ALL OUTPUTS TERMINATED AT 47K OHMS:**

**FREQUENCY RESPONSE:**

(Any in/out combination with 1 volt RMS output)  
+0, -2 dB, 20 Hz to 30 KHz

**SIGNAL-TO-NOISE RATIO:** (All channels on)

84 dB High Z line inputs  
80 dB Low Z mic inputs

**OVERALL DISTORTION:**

(Any in/out combination, 20 Hz - 20 KHz @ 1 volt RMS)  
Less than .05% THD, Typically below .01%

**EQUALIZATION:** (Graphic)

+/-15 dB @ 50 Hz, 100 Hz, 200 Hz, 400 Hz, 800 Hz, 1.5 KHz,  
3 KHz, 6 KHz and 12 KHz, Peak/Notch, Average Q of 1.8

**CROSSTALK:**

Greater than 60 dB @ 1 KHz

**MAXIMUM AVAILABLE GAIN:**

+12 dB Master Slider  
+12 dB Channel Slider  
+32 dB Input Control  
+14 dB Balanced Input Amp  
+70 dB Total

**LED READOUT RANGE:**

-21 to +6 dBV; Main A & B, Monitor A & B

**DDT DYNAMIC RANGE:**

Greater than 26 dB

**DDT MAXIMUM TOTAL HARMONIC DISTORTION:**

(1 KHz)  
Below 0.5% THD for 6 dB overload  
Below 1% THD for 20 dB overload

**XR-800™****EQUALIZATION:** (Each Channel)

+/-15 dB @ 60 Hz and 8 KHz, Shelving  
+/-15 dB @ 600 Hz, Peak/Notch

**POWER AMPLIFIER SECTION:**

(240SC module with DDT compression)

**FREQUENCY RESPONSE:**

+0, -1 dB, 20 Hz to 30 KHz @ 1 watt into 4 ohms

**RATED POWER AND LOAD:**

100 watts per channel into 4 ohms

**POWER @ CLIPPING:**

(1% THD, 1 KHz, 120 VAC line, Typical single channel)  
75 watts RMS into 8 ohms  
125 watts RMS into 4 ohms  
2 ohms not recommended

**TOTAL HARMONIC DISTORTION:**

Less than 0.1%, 100 mW to 100 watts RMS, 20 Hz to 200 KHz, 4 ohms, Typically below .05%

**INTERMODULATION DISTORTION:**

Less than 0.1%, 100 mW to 100 watts RMS, 60 Hz and 5 KHz, 4 ohms, Typically below .05%

**HUM AND NOISE:**

90 dB below 100 watts, 20 Hz - 20 KHz

**SLEW RATE:**

Greater than 15 V/uSec

**DAMPING FACTOR:**

Greater than 100 @ 1 KHz, 4 ohms

**INPUT SENSITIVITY:**

1 volt RMS for 100 watts into 4 ohms

**INPUT IMPEDANCE:**

22K ohms overload protected

**POWER CONSUMPTION:**

500 watts, 120 VAC, 50/60 Hz

**XR-1200™****EQUALIZATION:** (Each channel)

+/-15 dB @ 60 Hz and 8 KHz, Shelving  
+/-15 dB @ 600 Hz, Peak/Notch  
+/-17 dB overall combining

**POWER AMPLIFIER SECTION:**

(CS-400™ module with DDT compression)

**FREQUENCY RESPONSE:**

+0, -1 dB, 10 Hz to 30 KHz @ 1 watt into 4 ohms

**RATED POWER AND LOAD:**

200 watts per channel into 4 ohms

**POWER @ CLIPPING:**

(1% THD, 1 KHz, 120 VAC line, Typical single channel)  
130 watts RMS into 8 ohms  
240 watts RMS into 4 ohms  
130 watts RMS into 2 ohms

**TOTAL HARMONIC DISTORTION:**

Less than 0.1%, 20 mW to 200 watts RMS, 20 Hz to 20 KHz, 4 ohms, Typically below .05%

**HUM AND NOISE:**

95 dB below 200 watts, 20 Hz - 20 KHz

**SLEW RATE:**

Greater than 20 V/uSec

**DAMPING FACTOR:**

Greater than 100 @ 1 KHz, 4 ohms

**INPUT SENSITIVITY:**

1 volt RMS for 200 watts into 4 ohms

**INPUT IMPEDANCE:**

50K ohms overload protected

**POWER CONSUMPTION:**

900 watts, 120 VAC, 50/60 Hz



**SIGNAL FLOW CHART FOR THE XR-800™/XR-1200™**

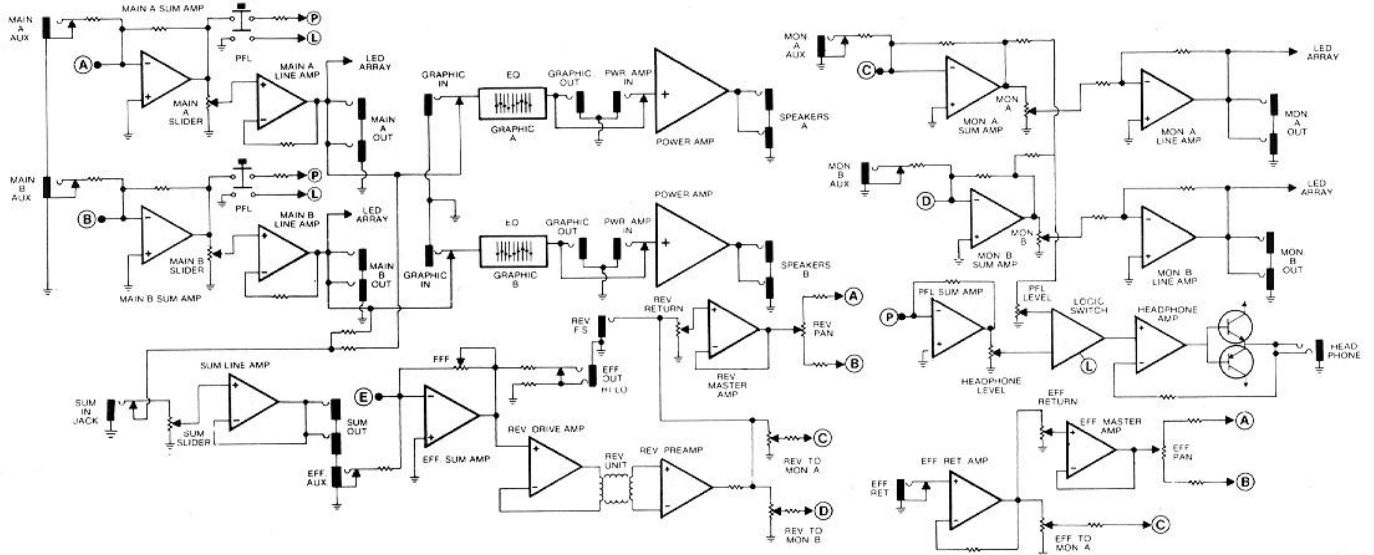
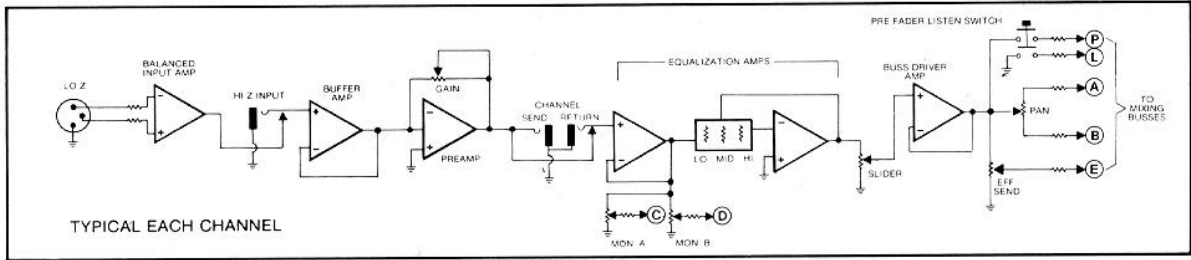

**DANGER**

EXPOSURE TO EXTREMELY HIGH NOISE LEVELS MAY CAUSE A PERMANENT HEARING LOSS. INDIVIDUALS VARY CONSIDERABLY IN SUSCEPTIBILITY TO NOISE INDUCED HEARING LOSS, BUT NEARLY EVERYONE WILL LOSE SOME HEARING IF EXPOSED TO SUFFICIENTLY INTENSE NOISE FOR A SUFFICIENT TIME. THE U.S. GOVERNMENT'S OCCUPATIONAL SAFETY AND HEALTH ADMINISTRATION (OSHA) HAS SPECIFIED THE FOLLOWING PERMISSIBLE NOISE LEVEL EXPOSURES:

DURATION PER DAY IN HOURS	SOUND LEVEL dBA, SLOW RESPONSE
8	90
6	92
4	95
3	97
2	100
1½	102
1	105
¾	110
½ or less	115

ACCORDING TO OSHA, ANY EXPOSURE IN EXCESS OF THE ABOVE PERMISSIBLE LIMITS COULD RESULT IN SOME HEARING LOSS. EAR PLUGS OR PROTECTORS IN THE EAR CANALS OR OVER THE EARS MUST BE WORN WHEN OPERATING THIS AMPLIFICATION SYSTEM IN ORDER TO PREVENT A PERMANENT HEARING LOSS IF EXPOSURE IS IN EXCESS OF THE LIMITS AS SET FORTH ABOVE. TO INSURE AGAINST POTENTIALLY DANGEROUS EXPOSURE TO HIGH SOUND PRESSURE LEVELS, IT IS RECOMMENDED THAT ALL PERSONS EXPOSED TO EQUIPMENT CAPABLE OF PRODUCING HIGH SOUND PRESSURE LEVELS SUCH AS THIS AMPLIFICATION SYSTEM BE PROTECTED BY HEARING PROTECTORS WHILE THIS UNIT IS IN OPERATION.

**CAUTION**

THIS MIXING CONSOLE/PREAMP HAS BEEN DESIGNED AND CONSTRUCTED TO PROVIDE ADEQUATE SIGNAL VOLTAGE FOR PLAYING MODERN MUSIC. IMPROPER USE OF THE GAIN/EQUALIZATION CONTROLS AND/OR IMPROPER USE OF INTERNAL/EXTERNAL BUSES MAY CREATE CLIPPING (SQUARE WAVES) AND POSSIBLY CAUSE SUBSEQUENT DAMAGE TO THE LOUDSPEAKER SYSTEMS. EXTENDED OPERATION OF THE GAIN/EQUALIZATION CONTROLS IN THEIR MAXIMUM POSITIONS IS THEREFORE, NOT RECOMMENDED. PLEASE BE AWARE THAT MAXIMUM POWER CAN BE OBTAINED WITH VERY LOW SETTINGS OF THE GAIN/EQUALIZATION CONTROLS IF THE INPUT SIGNAL IS VERY STRONG.

IT IS COMMON PRACTICE AMONG USERS OF SOUND REINFORCEMENT EQUIPMENT TO IDENTIFY THE INDIVIDUAL CHANNELS WITH A STRIP OF TAPE PLACED ABOVE OR BELOW THE ROW OF VOLUME FADERS. MANY TYPES OR BRANDS OF TAPE HAVE A VERY STRONG ADHESIVE WHICH CAN ABRADE THE PAINT ON THE FACEPLATE AND ACTUALLY REMOVE THE PAINT WHEN THE TAPE IS REMOVED. WE STRONGLY RECOMMEND THAT SCOTCH TAPE NOT BE USED ON PAINTED SURFACES NOR ANY OTHER TAPE THAT IS NOT ESPECIALLY DESIGNED FOR SUCH APPLICATIONS. MEDIUM OR LIGHT ADHESIVE MASKING OR MIXER LABEL TAPE IS RECOMMENDED IF TAPE IS USED. ANY TAPE LEFT ON PAINTED SURFACE FOR EXTENDED PERIODS WILL BE DIFFICULT TO REMOVE. NEVER USE CLEAR OR SCOTCH TAPE FOR THESE APPLICATIONS.

1. Read all safety and operating instructions before using this product.
2. All safety and operating instructions should be retained for future reference.
3. Obey all cautions in the operating instructions and on the back of the unit.
4. All operating instructions should be followed.
5. This product should not be used near water, i.e. a bathtub, sink, swimming pool, wet basement, etc.
6. This product should be located so that its position does not interfere with its proper ventilation. It should not be placed flat against a wall or placed in a built-in enclosure that will impede the flow of cooling air.
7. This product should not be placed near a source of heat such as a stove, heater, radiator or another heat producing amplifier.
8. Connect only to a power supply of the type marked on the unit adjacent to the power supply cord.
9. Never break off the ground pin on the power supply cord. For more information on grounding write for our free booklet "Shock Hazard and Grounding."
10. Power supply cords should always be handled carefully. Never walk or place equipment on power supply cords. Periodically check cords for cuts or signs of stress, especially at the plug and the point where the cord exits the unit.
11. The power supply cord should be unplugged when the unit is to be unused for long periods of time.
12. Metal parts can be cleaned with a damp rag. The vinyl covering used on some units can be cleaned with a damp rag, or an ammonia based household cleaner if necessary.
13. Care should be taken so that objects do not fall and liquids are not spilled into the unit through the ventilation holes or any other openings.
14. This unit should be checked by a qualified service technician if:
  - A. The power supply cord or plug has been damaged.
  - B. Anything has fallen or been spilled into the unit.
  - C. The unit does not operate correctly.
  - D. The unit has been dropped or the enclosure damaged.
15. The user should not attempt to service this equipment. All service work should be done by a qualified service technician.

Due to our efforts for constant improvement, features and specifications are subject to change without notice.

**PEAVEY ELECTRONICS CORPORATION**  
 711 A Street / Meridian, MS 39301 / U.S.A.  
 © 1982  
 Printed in U.S.A.  
 80370355 6/82

