

OPERATING INSTRUCTIONS



Intended to alert the user to the presence of uninsulated "dangerous voltage" within the product's enclosure that may be of sufficient magnitude to constitute a risk of electric shock to persons.



Intended to alert the user to the presence of important operating and maintenance (servicing) instructions in the literature accompanying the product.

CAUTION: Risks of electrical shock — DO NOT OPEN

CAUTION: To reduce the risk of electric shock, do not remove cover. No user serviceable parts inside. Refer Servicing to qualified service personnel.

MA™ 635T

Mixer Amplifier



PEAVEY®

ARCHITECTURAL
ACOUSTICS®

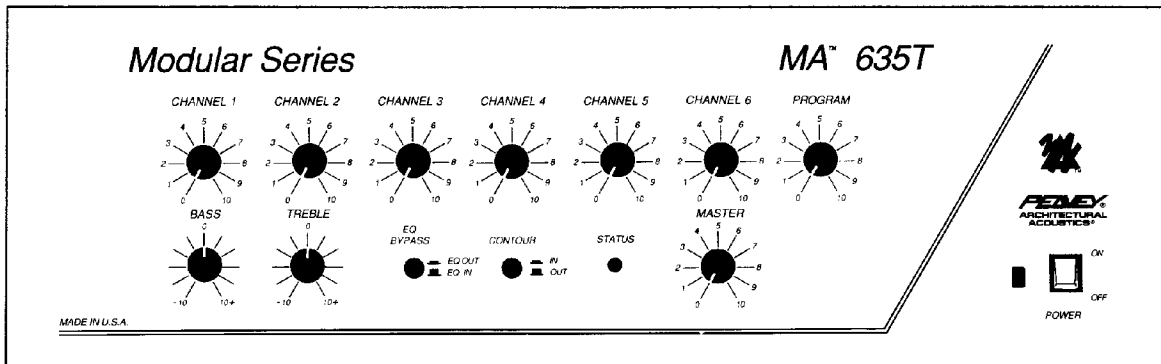

3

4

5

6

7

8

9

10

FEATURES:

- 7 channel mixer/power amplifier system
- 20 - 20 kHz frequency response
- Bridging input/output
- Dedicated program input
- Contour switch (special equalization)
- Bass and treble controls
- Preamp output/power amp input patch capability
- Short circuit and thermal protection
- SPS™ compression circuitry
- Built-in low cut filter (switchable from rear panel)
- Plug in module capability
- Output impedance variations: 4 ohm, 8 ohm, 25V, and 70V
- Rack-mountable or stand alone package
- 600 balanced output

General Description

The Architectural Acoustics MA™ 635T is a high quality mixer amplifier with seven separate input channels. Each channel provides a level control and the master output section features bass and treble EQ controls (defeatable), and special equalization contour.

The MA 635T provides unmatched application flexibility with an array of optional plug-in modules, allowing each system to be tailor-made for specialized installations. Input modules may be loaded in as required for varying sound reinforcement applications, number of input channels, special functions, etc.

The program input includes its own level control and is totally separate from the other six channels. External signals may be patched in at this point as a system auxiliary input or the seventh input channel. Signals appearing at this input are routed directly to the master summing amplifier stage and are mixed with signals from the other six channels. Systems requiring a single input may use the program

input and the purchase of an input module is not necessary. The program level control regulates the level of this input and the signal is routed through the system bass and treble controls.

The power section delivers 35 watts and includes built-in SPS™ compression which allows the MA 635T to produce full power capability without audible power amp clipping. A broad load impedance range is provided and twenty-five and seventy volt line outputs are standard equipment. The MA 635T is packaged as a stand-alone unit but will also rack-mount into a standard 19" rack.

1. Channel Level Control

Controls the signal level at the channel input.

2. Program Level Control

Controls the signal level at the program input.

3. Low EQ Control (Bass)

Active equalization control that adjusts the low frequency response. Clockwise rotation boosts lows while counterclockwise rotation provides a cut (reduction) of the low frequencies (± 10 dB).

4. High EQ Control (Treble)

Active equalization control that adjusts the high frequency response. Clockwise rotation boosts highs while counterclockwise rotation provides a cut (reduction) of the high frequencies (± 10 dB).

5. EQ Bypass

The "in" position of this switch bypasses bass and treble equalization. The "out" position allows operation of the equalization.

6. Contour Switch

The "in" position of this switch provides 6 dB boost at 100 Hz and 6 dB boost at 10 kHz. The "out" position removes boost from the system.

7. Status LED

Indicates output level from the master mixing stage. Bi-color illumination capability indicates signal activity (green) and 2 dB below clipping (red).

8. Master

Controls the overall volume level of the system.

9. Power On LED

Indicates when AC power is being supplied to the unit.

10. Power Switch

Depress to "on" position to turn on.

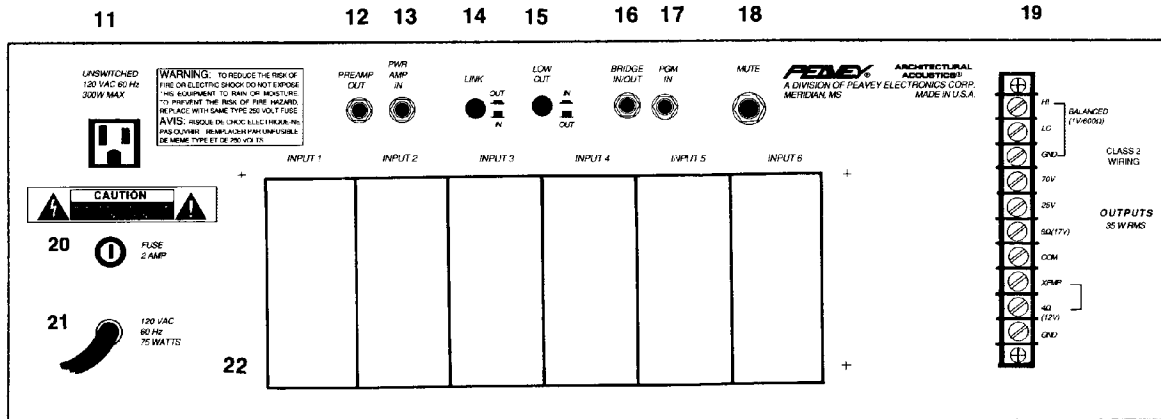

11. AC Outlet (Unswitched)

Provides AC power for auxiliary equipment with power consumption 300 watts maximum.

12. Preamp Out

Provides output signal to outboard gear for signal processing. Compressors, limiters, equalizers, etc., may be patched into the loop from this point. Signal from output of signal processor should return to power amp input. The "link" switch should be in the "in" position for this operation.

13. Power Amp Input

Provides access directly to the power amp. When using this input the "link" switch should be in the "in" position.

14. Link Switch

Breaks the signal flow routing from the preamp to the power amp when the link switch is in the "in" position, allowing external signals to be patched in at this point.

15. Low Cut Switch

Provides a 6 dB/octave low frequency roll-off at 60 Hz. The "in" position activates the low cut. The "out" position defeats the low cut.

16. Bridge In/Out

Provides output signal that is independent of the Master level control, Bass and Treble controls. It also may be used as a mixing output point when the similar terminal of another amplifier is connected to this terminal. A separate tape recording output may be taken from this point without interaction of EQ and master level control.

17. Program In

Accepts signals from other sources such as another mixer or mixer amplifier. Signal level at this input is controlled by the Program level control and is fed to the Master output. The program in may be regarded as channel "seven" without plug-in module capability.

NOTE: This input is muted whenever the mute line is grounded.

18. Mute

Plug-in modules are available with muting function. The mute line may be activated with an external switch at this point.

19. Outputs

A direct output, as well as several transformer outputs, are provided to allow the proper interface between the amplifier and the speaker system. The direct output allows direct connection to a 4 ohm speaker system. To use this output, disconnect the jumper between the 4 ohm terminal and the XFMR terminal. Connect the speaker (or speakers) from the GND terminal to the 4 ohm terminal. 8 ohm, 25 volt, and 70 volt outputs are also provided. To use these outputs, the jumper between 4 ohm and XFMR must be installed. For 8 ohm speaker systems, connect between the COM terminal and the 8 ohm output. 25V and 70V outputs are also provided for "constant voltage" speaker distribution systems. The 25V output connection is between the COM terminal and the 25V terminal and the 70V output is between the COM terminal and the 70V terminal. The MA 635T also features a balanced, transformer isolated line level output. This output is provided for direct con-

nection to "music on hold" systems, booster power amplifiers, etc. The balanced output is designed to deliver 1V RMS into a 600 ohm load.

20. Fuse

Replace with the same size and rating.

21. Power Cord

Connect to 120V AC power source.

22. Module Input Ports

Accepts plug-in modules for all six channels. Input modules are optional and should be selected by installation requirements.

NOTE: All modules will function in any of the six ports.

SPECIFICATIONS

Output Power:

35 watts

Power Bandwidth:

Direct: 20-20K < 0.5% THD
XFMR: 50-20K < 0.5% THD

Frequency Response:

Direct: 20-20K \pm 1.0 dB
XFMR: 20-20K \pm 3 dB

THD:

0.02% at 1 kHz rated power

Output Regulation:

Direct: <0.5 dB
XFMR: <1.0 dB

S/N Ratio:

Master Volume Min: 95 dB
Master Volume Max: 79 dB
Power Amp Only: 100 dB

Tone Controls:

Bass: \pm 10 dB @ 100 Hz
Treble: \pm 10 dB @ 10 kHz

Contour:

+6 dB @ 100 Hz
+6 dB @ 10 kHz

Inputs:

Six input ports, one dedicated program input bridge in/out

Input Sensitivity:

Ports 1-6 and PGM: 100 mV @ 10K ohms
Bridge in/out: 100 mV/3.3K ohms

Preamp Out/Power Amp In:

1.0 V @ 600 ohms/1.0 V @ 15K ohms

Outputs:

Direct Out: 4 ohms
XFMR: 8 ohms, 25 volts, 70 volts (balanced)

Controls:

7 input gain controls, 1 bass control, 1 treble control, 1 contour switch, 1 master gain control, 1 power switch, 1 EQ defeat switch, 1 link switch, 1 low-cut switch

Indicators:

Power LED, Bi-color (green/red) status LED

Protection:

Internal current limiting, SPS (speaker protection) output relays, 1 line fuse (external), and 2 internal fuses

Connectors:

Preamp Out, Power Amp In, PGM input, bridge in/out, RCA phono jack, Ports 1-6: Card edge connector, Outputs: Screw terminals, Mute: 1/4" jack, AC SJT, 3 prong

Power Consumption:

AC 120 volts, 60 Hz, 75 watts

Dimensions:

5.20" (H) x 17.00" (W) 12.625" (D)

Color:

Gray

Other Features:

600 ohm output
Output disconnected for 4 seconds after power on.

70V "Constant Voltage" Distribution System

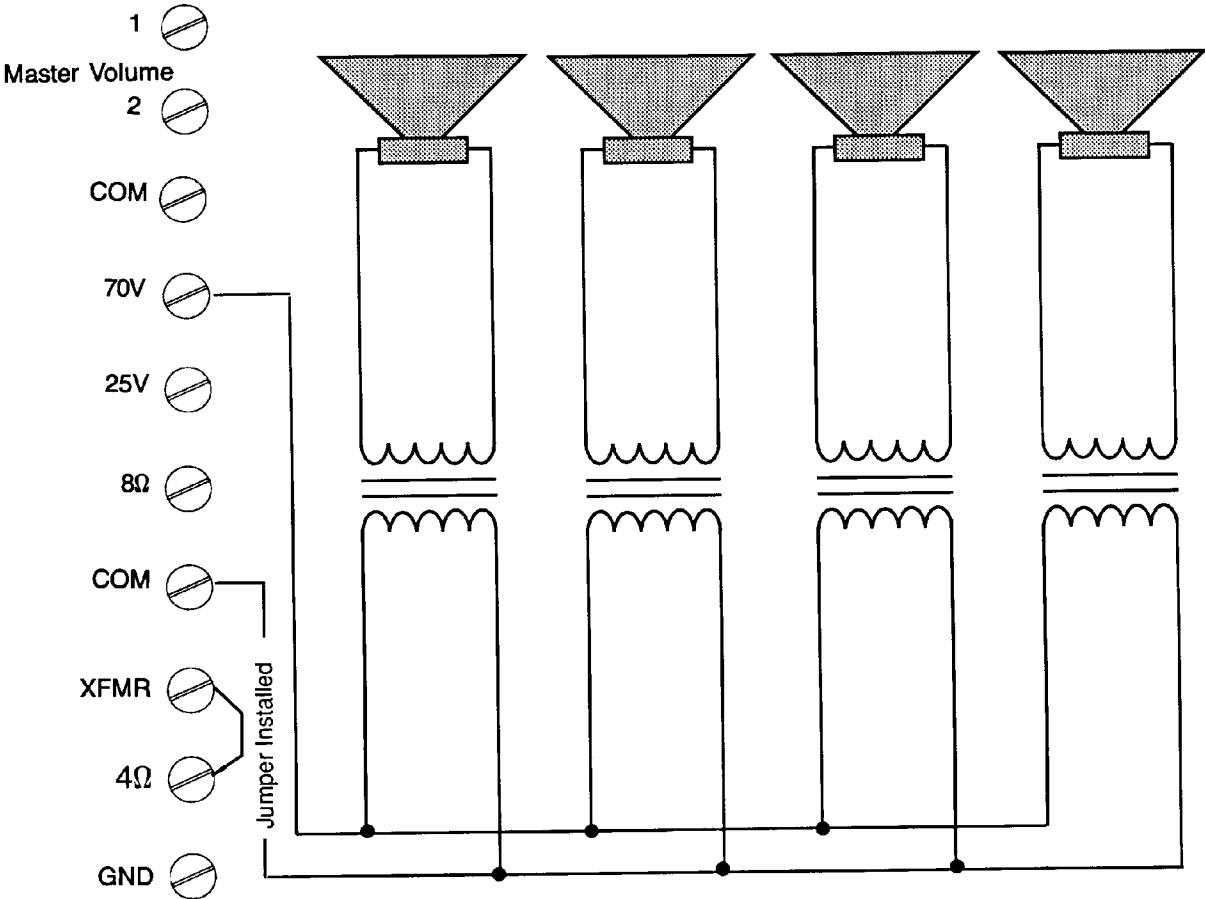

1 V Balanced Output Connectors

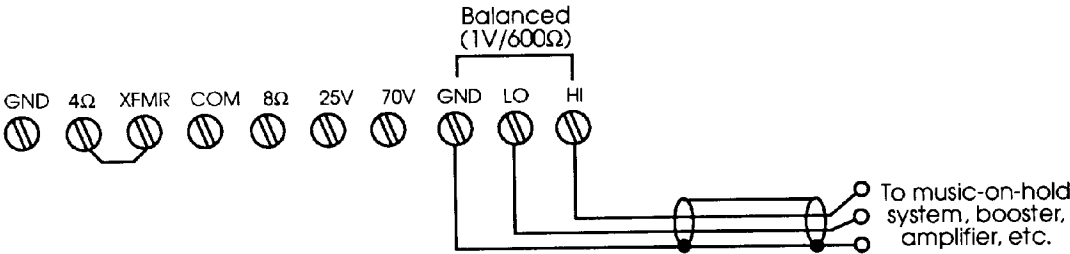

Direct output to 4Ω Speaker

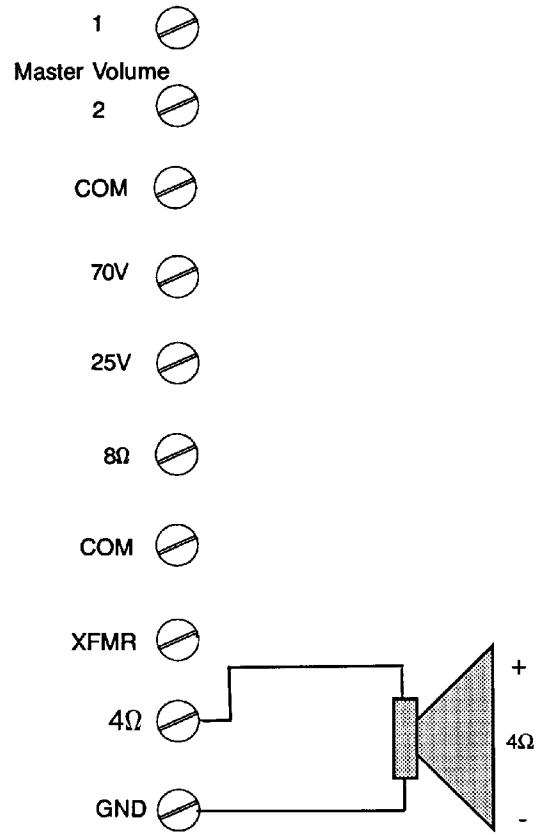

BLOCK DIAGRAM

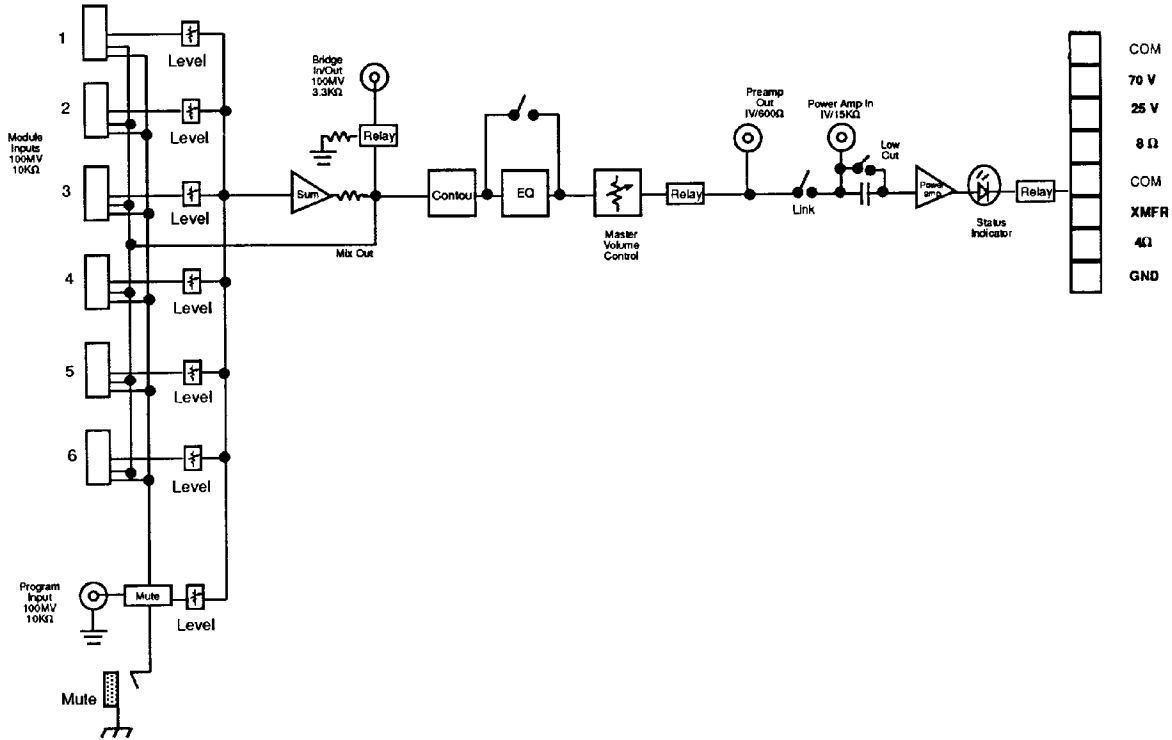

DANGER

EXPOSURE TO EXTREMELY HIGH NOISE LEVELS MAY CAUSE A PERMANENT HEARING LOSS. INDIVIDUALS VARY CONSIDERABLY IN SUSCEPTIBILITY TO NOISE INDUCED HEARING LOSS, BUT NEARLY EVERYONE WILL LOSE SOME HEARING IF EXPOSED TO SUFFICIENTLY INTENSE NOISE FOR A SUFFICIENT TIME. THE U.S. GOVERNMENT'S OCCUPATIONAL SAFETY AND HEALTH ADMINISTRATION (OSHA) HAS SPECIFIED THE FOLLOWING PERMISSIBLE NOISE LEVEL EXPOSURES:

DURATION PER DAY IN HOURS	SOUND LEVEL, dBA, 8-HOUR RESPONSE
8	90
6	92
4	95
3	97
2	100
1 1/2	102
1	105
3/4	110
1/2 or less	115

ACCORDING TO OSHA, ANY EXPOSURE IN EXCESS OF THE ABOVE PERMISSIBLE LIMITS COULD RESULT IN SOME HEARING LOSS. EAR PLUGS OR EARPLUGS IN THE EAR CANALS, OR OVER THE EAR, MUST BE WORN WHEN OPERATING THIS AMPLIFICATION SYSTEM IN ORDER TO PREVENT A PERMANENT HEARING LOSS IF EXPOSURE IS IN EXCESS OF THE LIMITS SET FORTH ABOVE AND INSURE AGAINST POTENTIALLY EXCESSIVE EXPOSURE TO HIGH SOUND PRESSURE LEVELS. IT IS RECOMMENDED THAT ALL PERSONS EXPOSED TO EQUIPMENT CAPABLE OF PRODUCING HIGH SOUND PRESSURE LEVELS SUCH AS THIS AMPLIFICATION SYSTEM BE INSPECTED BY A HEARING PROFESSIONAL WHILE THE UNIT IS IN OPERATION.

CAUTION

THIS AMPLIFIER HAS BEEN DESIGNED AND CONSTRUCTED TO PROVIDE ADEQUATE POWER RESERVE FOR PLAYING MODERN MUSIC WHICH MAY REQUIRE OCCASIONAL PEAK POWER. ADEQUATE POWER RESERVE FOR "BASS BOOST" HAS BEEN DESIGNED INTO THIS SYSTEM. UNDESIRED OPERATION AT ABOVE MAXIMUM POWER LEVELS MAY DAMAGE THE ASSOCIATED SPEAKER SYSTEM. PLEASE BE AWARE THAT MAXIMUM POWER CAN BE OBTAINED WITH VERY LOW SETTINGS OF THE GAIN CONTROLS IF THE INPUT SIGNAL IS VERY STRONG.

- Read all safety and operating instructions before using this product.
- All safety and operating instructions should be retained for future reference.
- Obey all cautions in the operating instructions and on the back of the unit.
- All operating instructions should be followed.
- This product should not be used near water, i.e. a bathtub, sink, swimming pool, well basement, etc.
- This product should be located so that its position does not interfere with its proper ventilation. It should not be placed flat against a wall or placed in a built-in enclosure that will impede the flow of cooling air.
- This product should not be placed near a source of heat such as a stove, radiator or another heat producing amplifier.
- Connect only to a power supply of the type marked on the back of the power supply used.
- Always unplug the ground pin of the power supply used. For more information on grounding write for our free booklet "Shock Hazard and Grounding."
- Power supply cords should always be handled carefully. Never walk or place equipment on power supply cords. Periodically check cords for cuts or signs of stress, especially at the plug and the point where the cord exits the unit.
- The power supply cord should be unplugged when the unit is to be unused for long periods of time.
- If this product is to be mounted in an equipment rack, rear support should be provided.
- When parts are cleaned with a damp rag, the vinyl control knobs on some units should be cleaned with a damp rag containing a nonion based household cleaner if necessary.
- Care should be taken so that objects do not fall and liquids are not spilled into the unit through the ventilation holes or any other openings.
- This unit should be checked by a qualified service technician if:
 - The power supply cord or plug has been damaged.
 - Anything has fallen or been spilled into the unit.
 - The unit does not operate correctly.
 - The unit has been dropped or the enclosure damaged.
- The user should not attempt to service this equipment. All service work should be done by a qualified service technician.

LIMITED WARRANTY

Peavey Electronics Corporation warrants to the original purchaser of this new Architectural Acoustics product that it is free from defects in material and workmanship. If within one (1) year from date of purchase a properly installed product proves to be defective and Peavey is notified, Peavey will repair or replace it at no charge. (Note: Batteries and patch cords not covered.) "Original purchaser" means the customer for whom the product is originally installed.

Damage resulting from improper installation, interconnection of a unit or system of another manufacturer, accident or unreasonable use, neglect or any other cause not arising from defects in material and workmanship is not covered by this warranty. The warranty is valid only as to products purchased and installed in the United States.

THIS LIMITED WARRANTY IS IN LIEU OF ANY AND ALL WARRANTIES, EXPRESSED OR IMPLIED, INCLUDING THE IMPLIED WARRANTIES OF MERCHANTABILITY AND FITNESS FOR A PARTICULAR USE. UNDER NO CIRCUMSTANCES WILL PEAVEY BE LIABLE FOR ANY LOST PROFITS, LOST SAVINGS, INCIDENTAL DAMAGES OR CONSEQUENTIAL DAMAGES ARISING OUT OF THE USE OR INABILITY TO USE THE PRODUCT, EVEN IF PEAVEY HAS BEEN ADVISED OF THE POSSIBILITY OF SUCH DAMAGE. THIS LIMITED WARRANTY IS THE ONLY EXPRESSED WARRANTY ON THIS PRODUCT, AND NO OTHER STATEMENT, REPRESENTATION, WARRANTY, OR AGREEMENT BY ANY PERSON SHALL BE VALID OR BINDING UPON PEAVEY.

Peavey's liability to the original purchaser for damages for any cause whatsoever and regardless of the form of action, is limited to the actual damages up to the greater of Five Hundred Dollars (\$500) or an amount equal to the purchase price of the product that caused the damage or that is the subject of or is directly related to the cause of action. This limitation of liability will not apply to claims for personal injury or damage to real property or tangible personal property allegedly caused by Peavey's negligence. For information on service under this warranty, call a Peavey customer service representative at (601) 483-5376.



Features and specifications subject to change without notice.

A Division of Peavey Electronics Corporation

711 A Street, P. O. Box 2898, Meridian, MS 39302-2898 / (601) 483-5376 / Telex 504115 / Fax (601) 484-4278