

# OWNERS MANUAL

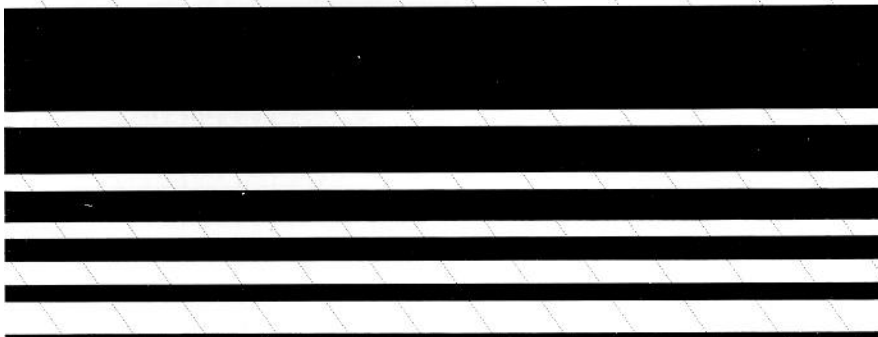

## ***PRODUCTION MIXER™ 502***



WARNING: TO PREVENT ELECTRICAL SHOCK OR FIRE HAZARD, DO NOT EXPOSE THIS APPLIANCE TO RAIN OR MOISTURE. BEFORE USING THIS APPLIANCE, READ THE OPERATING GUIDE FOR FURTHER WARNINGS.

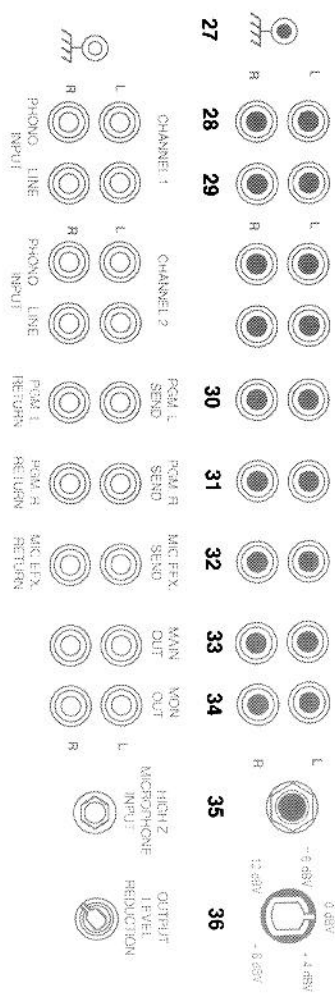

16.5 V 1 AMP  
AC INPUT

A PRODUCT OF PEAVEY ELECTRONICS CORP.  
MERIDIAN MS  
MADE IN U.S.A.

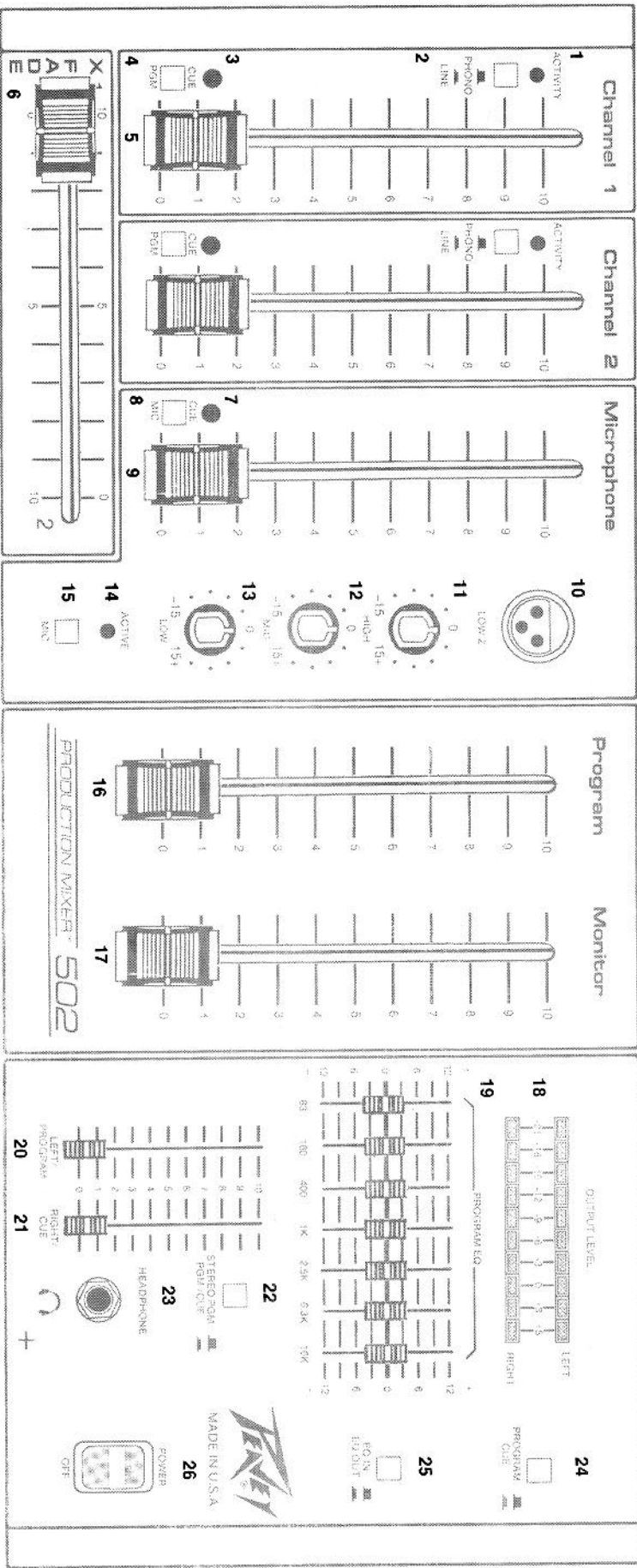

**CAUTION:** TO PREVENT THE RISK OF FIRE AND SHOCK HAZARD, DO NOT EXPOSE THIS APPLIANCE TO RAIN OR MOISTURE, DO NOT REMOVE FROM CASE, NO USER SERVICEABLE PARTS INSIDE. REFER SHIPPING TO QUALIFIED SERVICE PERSONNEL.

AVIS: RISQUE DE CHOC ELECTRIQUE - NE PAS OUVRIRE

**ACTIVITY LED (1)**

Provides dynamic signal indication at the input. This LED is peak responsive and under most conditions will indicate tempo.

**PHONO/LINE SWITCH (2)**

Allows selection of phono (L and R) or line (L and R) inputs. The "in" position of this switch selects "line" and the "out" position selects "phono".

**CUE LED (3)**

Indicates that signal is routed to cue system.

**PROGRAM CUE SWITCH (4)**

The "in" position of this switch routes channel signal to cue system.

**CHANNEL LEVEL SLIDER (5)**

A stereo slider that determines the output level of the channel.

**NOTE:**

Channel 2 functions are identical to Channel 1.

**CROSSFADE SLIDER (6)**

A stereo slider which allows crossfade capability between Channels 1 and 2. Full left positioning of this control places the output on Channel 1 only. Full right positioning places the output on Channel 2. The mid point of slider travel creates a mixed output from both Channel 1 and Channel 2. Blending and cross fading from Channel 1 to Channel 2 is possible between full left and full right positioning.

**MICROPHONE CHANNEL****CUE LED (7)**

Indicates that signal from the Microphone Channel is routed to cue system.

**MIC CUE SWITCH (8)**

The "in" position of this switch routes microphone signal to cue system.

**MICROPHONE LEVEL SLIDER (9)**

A mono slider that determines the output level of the Microphone Channel.

**BALANCED LOW Z MICROPHONE INPUT (10)**

For use with low impedance microphones or low level sources equipped with an XLR connector.

**HIGH EQ (11)**

An active tone control (shelving type, +/- 15 dB) that varies the high frequency range.

**MID EQ (12)**

An active tone control (peak/notch, +/- 15 dB) that adjusts the mid frequency range.

**LOW EQ (13)**

An active tone control (shelving type, +/- 15 dB) that varies the low frequency boost or cut.

**ACTIVE LED (14)**

Indicates that Microphone Channel is active.

**MIC SWITCH (15)**

The "in" position of this switch activates Microphone Channel.

**NOTE:**

The Microphone Channel has automatic talkover capability. When Mic Channel is activated the program level from Channels 1 and 2 drops -6 dB.

**PROGRAM MASTER LEVEL (16)**

A stereo slider that determines the overall program level from Channel 1, Channel 2 and the Microphone Channel.

**MONITOR LEVEL CONTROL (17)**

A stereo slider that determines the overall monitor level from Channel 1, Channel 2 and the Microphone Channel.

**LED ARRAYS (LEFT AND RIGHT) (18)**

Two calibrated, switch-selectable LED arrays are provided to visually indicate output levels of program or cue (L and R). See program/cue switch.

**PROGRAM EQ (19)**

A 7-band, stereo graphic equalizer that provides +/- 12 dB boost or cut at each center frequency. The equalizer is functional on both the program signal and monitor signal and is switch selectable. See EQ in/out switch.

**LEFT/PROGRAM LEVEL (20)**

A slider that controls the left program level in the stereo program mode or entire program level in the program/cue mode. See Stereo PGM/Cue switch.

**RIGHT/CUE LEVEL (21)**

A slider that controls the right program level in the stereo program mode or entire cue level in the program/cue mode. See Stereo PGM/Cue switch.

**STEREO PGM — PGM/CUE SWITCH (22)**

The "out" position of this switch allows headphone monitoring of stereo program with slider level controls for L and R. The "in" position allows the program to be monitored in mono on the left side and the cue system in mono on the right side.

**HEADPHONE JACK (23)**

Stereo headphones patched in at this point will allow monitoring of program material or cueing system. **Note:** Do not use mono headphones with this system.

**PROGRAM/CUE SWITCH (24)**

The "in" position of this switch places stereo LED array on output of cue system. The "out" position places the LED array on output of program.

**EQ IN/EQ OUT SWITCH (25)**

The "out" position of this switch activates the stereo graphic EQ on the program output. The "in" position removes the graphic from the program output.

**POWER SWITCH (26)**

Depress to "on" position to turn on.

**GROUND LUG (27)**

Chassis grounds from other pieces of equipment should be connected at this point to minimize ground loop possibilities between power amps, outboard signal processing, turntables, etc.

**PHONO INPUTS (28)**

Left and right inputs are provided for output from turntables on each channel. See phono/line switch.

**LINE INPUTS (29)**

Left and right inputs are provided for "line level" signals from tape decks, CD's or other sources. See phono/line switch.

**PROGRAM LEFT — SEND AND RETURN (30)**

Send and return jacks are provided for patching of external effects graphic equalizers, or other signal processing at the left program channel.

**PROGRAM RIGHT — SEND AND RETURN (31)**

Send and return jacks are provided for patching of external effects graphic equalizers, or other signal processing at the right program channel.

**MIC EFFECTS — SEND AND RETURN (32)**

Send and return jacks are provided for patching of external effects graphic equalizers, or other signal processing at the microphone channel.

**MAIN OUTPUT (33)**

Left and right jacks are provided for the main (program) output. The outputs at this point should be patched out to the stereo power amplifiers driving the main speaker system.

**MONITOR OUTPUT (34)**

Left and right jacks are provided for the monitor output. When monitor system is required, the outputs at this point should be patched out to stereo power amplifier driving the monitor enclosures.

**HIGH Z MIC INPUT (35)**

A high impedance microphone input that is controlled by the microphone level slider on front panel.

**NOTE:**

When high Z mic is patched at this point, XLR mic input on the front panel is inactivated.

**OUTPUT LEVEL REDUCTION (36)**

A calibrated level control that varies the output level of the main signal from -12 dBV to +8 dBV.

**NOTE:**

Any increase or decrease in level with this control is not indicated at the LED arrays. Monitor output level is unaffected by this control.

**AC INPUT (37)**

External 16.5 volt, 1 amp power supply should be plugged in at this point.

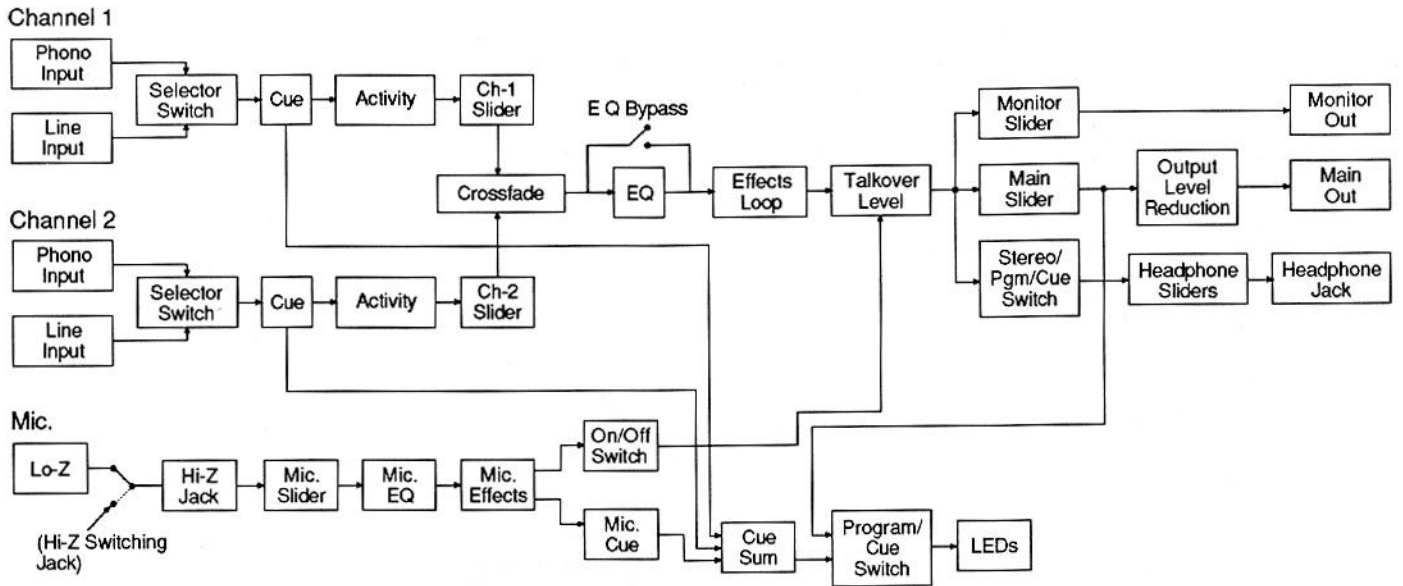

THIS BLOCK DIAGRAM SHOWS THE SIGNAL PATH WITHIN THE UNIT. IN ORDER TO THOROUGHLY UNDERSTAND THE FUNCTIONS OF THE UNIT, PLEASE STUDY THE BLOCK DIAGRAM CAREFULLY.

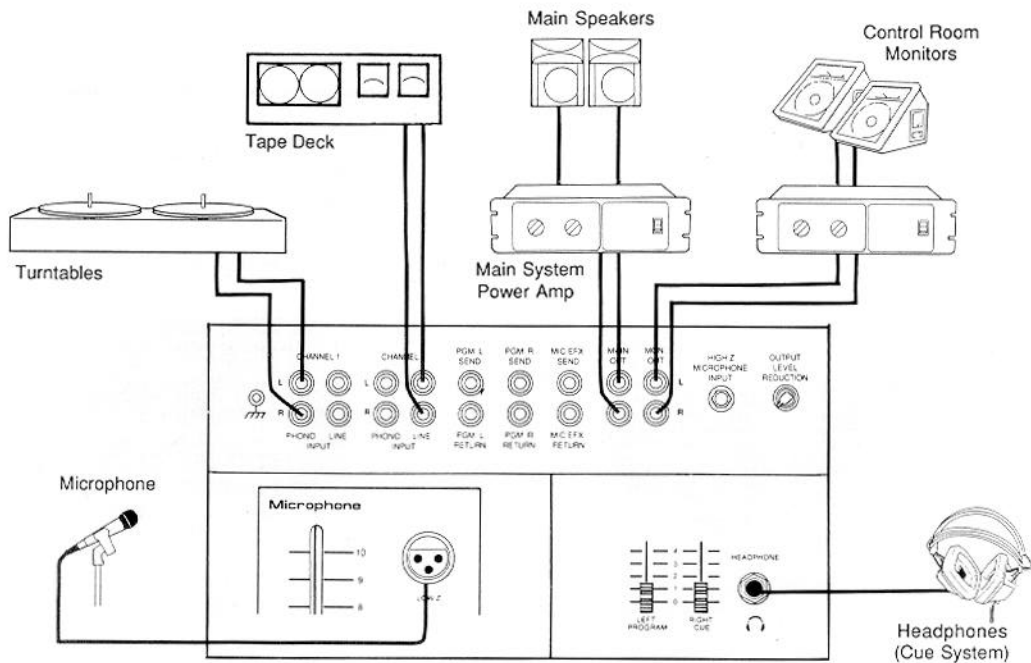

System Patch

**PRODUCTION MIXER™ 502 SPECS:**

**SUMMARY OF FUNCTIONS:**

2 switchable phone/line stereo inputs; 1 mic channel input; 1 stereo effects loop; 1 microphone effects loop; 1 stereo main unbalanced output; 1 stereo monitor unbalanced output; 7-band switchable EQ (will effect both main and monitor signals); dual/switchable LED ladders; switchable stereo headphone jack; channel 1/channel 2 crossfade slider, main output level reduction pot (-12/+8 dBV)

**CHANNEL 1-2 FEATURES:**

1 stereo (RIAA) phono input; 1 stereo line input; phone/line input selector switch; activity LED; switchable cue signal with LED; 100 mm stereo level slider

**MICROPHONE CHANNEL FUNCTIONS:**

1 low Z balanced microphone input; 1 High Z unbalanced microphone input (defeats Low Z Input); 3-band EQ; MIC On/Off Switch (with 6 dBV attenuation of program signal); switchable cue signal with LED

**PHONO INPUTS:**

Input Sensitivity: -46 dBV (5 mV)  
Input Impedance: 47K ohms  
Max Input Level: -23.7 dBV (65 mV) at 1 kHz

**LINE INPUTS:**

Input Sensitivity: -9.1 dBV (.35V)  
Input Impedance: 47K ohms  
Max Input Level: +15 dBV (5.6V) at 1 kHz

**MICROPHONE INPUT (LOW Z):**

Input Sensitivity: -40 dBV (10 mV)  
Input Impedance: 3.3K ohms  
Max Input Level: -10.75 dBV (.29V) at 1 kHz

**MICROPHONE INPUT (HIGH Z):**

Input Sensitivity: -22.5 dBV (75 mV)  
Input Impedance: 220K ohms  
Max Input Level: +4 dBV (1.6) at 1 kHz

**MICROPHONE TALKOVER:**

-6 dB with MIC "active" switch enabled

**FREQUENCY RESPONSE:**

Phono Inputs: Equalized to RIAA, 20 Hz to 20 kHz  
Line Inputs: 30 Hz - 30 kHz, +0/-3dB  
Mic Inputs: 30 Hz - 30 kHz, +0/-3dB  
Headphone: 40 Hz - 20 kHz, +0/-3dB

**SIGNAL TO NOISE RATIOS:**

Phono (10 mV at 1 kHz): Greater than 80 dB  
Line (-10 dBV at 1 kHz): Greater than 80 dB

**THD:**

Greater than .03% (40 Hz - 20 kHz at +6 dBV)

**PROGRAM/MONITOR EQ:**

7-band master EQ with bypass switch; 30 mm stereo sliders; -12/+12 dB peak/notch filters; center frequencies at 63 Hz, 160 Hz, 400 Hz, 1 kHz, 2.5 kHz, 6.3 kHz, 16 kHz

**MICROPHONE EQ:**

Low: +/- 15 dB shelving filter at 40 Hz  
Mid: +/- 15 dB peak notch filter at 600 Hz  
High: +/- 15 dB shelving filter at 15 kHz

**MAX OUTPUT LEVEL:**

+18.1 dBV (8V)

**POWER REQUIREMENTS:**

16.5 VAC, 1A external power supply

Features and specifications are subject to change without notice.

**DANGER**

EXPOSURE TO EXTREMELY HIGH NOISE LEVELS MAY CAUSE A PERMANENT HEARING LOSS. INDIVIDUALS VARY CONSIDERABLY IN SUSCEPTIBILITY TO NOISE INDUCED HEARING LOSS. BUT NEARLY EVERYONE WILL LOSE SOME HEARING IF EXPOSED TO SUFFICIENTLY INTENSE NOISE FOR A SUFFICIENT TIME. THE U.S. GOVERNMENT'S OCCUPATIONAL SAFETY AND HEALTH ADMINISTRATION (OSHA) HAS SPECIFIED THE FOLLOWING PERMISSIBLE NOISE LEVEL EXPOSURES

DURATION PER DAY IN HOURS	SOUND LEVEL dBA, SLOW RESPONSE
8	90
6	92
4	95
3	97
2	100
1½	102
1	105
¾	110
½ or less	115

ACCORDING TO OSHA, ANY EXPOSURE IN EXCESS OF THE ABOVE PERMISSIBLE LIMITS COULD RESULT IN SOME HEARING LOSS. EAR PLUGS OR PROTECTORS IN THE EAR CANALS OR OVER THE EARS MUST BE WORN WHEN OPERATING THIS AMPLIFICATION SYSTEM IN ORDER TO PREVENT A PERMANENT HEARING LOSS IF EXPOSURE IS IN EXCESS OF THE LIMITS AS SET FORTH ABOVE. TO INSURE AGAINST POTENTIALLY DANGEROUS EXPOSURE TO HIGH SOUND PRESSURE LEVELS, IT IS RECOMMENDED THAT ALL PERSONS EXPOSED TO EQUIPMENT CAPABLE OF PRODUCING HIGH SOUND PRESSURE LEVELS SUCH AS THIS AMPLIFICATION SYSTEM BE PROTECTED BY HEARING PROTECTORS WHILE THIS UNIT IS IN OPERATION.

**CAUTION**

THIS MIXING CONSOLE EFFECTS DEVICE (REAR) HAS BEEN DESIGNED AND CONSTRUCTED TO PROVIDE ADEQUATE SIGNAL (VOLTAGE) FOR PLAYING MODERN MUSIC. IMPROPER USE OF THE GAIN/EQUALIZER CONTROLS AND/OR IMPROPER USE OF INTERNAL/EXTERNAL BUSES MAY CREATE CLIPPING (SQUARE WAVES) AND POSSIBLY CAUSE SUBSEQUENT DAMAGE TO THE LOUDSPEAKER SYSTEMS. EXTENDED OPERATION OF THE GAIN/EQUALIZATION CONTROLS IN THEIR MAXIMUM POSITIONS IS THEREFORE NOT RECOMMENDED. PLEASE BE AWARE THAT MAXIMUM POWER CAN BE OBTAINED WITH VERY LOW SETTINGS OF THE GAIN/EQUALIZATION CONTROLS IF THE INPUT SIGNAL IS VERY STRONG.

IT IS COMMON PRACTICE AMONG USERS OF SOUND REINFORCEMENT EQUIPMENT TO IDENTIFY THE INDIVIDUAL CHANNELS WITH A STRIP OF TAPE PLACED ABOVE OR BELOW THE ROW OF VOLUME FADERS. MANY TYPES OR BRANDS OF TAPE HAVE A VERY STRONG ADHESIVE WHICH CAN INHIBIT THE PAINT ON THE FACER PLATE AND ACTUALLY REMOVE THE PAINT WHEN THE TAPE IS REMOVED. WE STRONGLY RECOMMEND THAT SCOTCH TAPE NOT BE USED ON PAINTED SURFACES NOR ANY OTHER TAPE THAT IS NOT ESPECIALLY DESIGNED FOR THESE APPLICATIONS. MEDIA OF LIGHT ADHESIVE (WRAPPING OR LABEL TAPE) IS RECOMMENDED IF TAPE IS USED. ANY TAPE LEFT ON PAINTED SURFACE FOR EXTENDED PERIODS WILL BE DIFFICULT TO REMOVE. NEVER USE CLEAR OR SCOTCH TAPE FOR THESE APPLICATIONS.

1. Read all safety and operating instructions before using this product.
2. All safety and operating instructions should be retained for future reference.
3. Obey all cautions in the operating instructions and on the back of the unit.
4. All operating instructions should be followed.
5. This product should not be used near water, i.e. a bathtub, sink, swimming pool, wet basement, etc.
6. This product should be located so that its position does not interfere with its proper ventilation. It should not be placed flat against a wall or placed in a built-in enclosure that will impede the flow of cooling air.
7. This product should not be placed near a source of heat such as a stove, radiator or another heat producing amplifier.
8. Connect only to a power supply of the type marked on the unit adjacent to the power supply cord.
9. Never break off the ground pin on the power supply cord. For more information on grounding write for our free booklet "Shock Hazard and Grounding".
10. Power supply cords should always be handled carefully. Never walk or place equipment on power supply cords. Periodically check cords for cuts or signs of stress, especially at the plug and the point where the cord exits the unit.
11. The power supply cord should be unplugged when the unit is to be unused for long periods of time.
12. If this product is to be mounted in an equipment rack, rear support should be provided.
13. Metal parts can be cleaned with a damp rag. The vinyl covering used on some units can be cleaned with a damp rag, or an ammonia based household cleaner if necessary.
14. Care should be taken so that objects do not fall and liquids are not spilled into the unit through the ventilation holes or any other openings.
15. This unit should be checked by a qualified service technician if:
  - A. The power supply cord or plug has been damaged.
  - B. Anything has fallen or been spilled into the unit.
  - C. The unit does not operate correctly.
  - D. The unit has been dropped or the enclosure damaged.
16. The user should not attempt to service this equipment. All service work should be done by a qualified service technician.



**THIS LIMITED WARRANTY VALID ONLY WHEN PURCHASED AND REGISTERED IN THE UNITED STATES OR CANADA. ALL EXPORTED PRODUCTS ARE SUBJECT TO WARRANTY AND SERVICES TO BE SPECIFIED AND PROVIDED BY THE AUTHORIZED DISTRIBUTOR FOR EACH COUNTRY.**

**Ces clauses de garantie ne sont valables qu'aux Etats-Unis et au Canada. Dans tous les autres pays, les clauses de garantie et de maintenance sont fixées par le distributeur national et assurées par lui selon la législation en vigueur.**

**Diese Garantie ist nur in den USA and Kanada gültig. Alle Export-Produkte sind der Garantie und dem Service des Importeurs des jeweiligen Landes unterworfen.**

**Esta garantía es válida solamente cuando el producto es comprado en E.U. continentales o en Canada. Todos los productos que sean comprados en el extranjero, están sujetos a las garantías y servicio que cada distribuidor autorizado determine y ofrezca en los diferentes países.**

#### **ONE-YEAR LIMITED WARRANTY/REMEDY**

PEAVEY ELECTRONICS CORPORATION ("PEAVEY") warrants this product, EXCEPT for covers, footswitches, patchcords, tubes and meters, to be free from defects in material and workmanship for a period of one (1) year from date of purchase, PROVIDED, however that this limited warranty is extended only to the original retail purchaser and is subject to the conditions, exclusions and limitations hereinafter set forth:

#### **PEAVEY 90-DAY LIMITED WARRANTY ON TUBES AND METERS**

If this product contains tubes or meters, Peavey warrants the tubes or meters contained in the product to be free from defects in material and workmanship for a period of ninety (90) days from date of purchase; PROVIDED, however, that this limited warranty is extended only to the original retail purchaser and is also subject to the conditions, exclusions and limitations hereinafter set forth.

#### **CONDITIONS, EXCLUSIONS AND LIMITATIONS OF LIMITED WARRANTIES**

These limited warranties shall be void and of no effect if:

- The first purchase of the product is for the purpose of resale; or
- The original retail purchase is not made from an AUTHORIZED PEAVEY DEALER; or
- The product has been damaged by accident or unreasonable use, neglect, improper service or maintenance, or other causes not arising out of defects in material or workmanship; or
- The serial number affixed to the product is altered, defaced or removed.

In the event of a defect in material and/or workmanship covered by this limited warranty, Peavey will:

- In the case of tubes or meters, replace the defective component without charge;
- In other covered cases (i.e., cases involving anything other than covers, footswitches, patchcords, tubes or meters), repair the defect in material or workmanship or replace the product, at Peavey's option; and provided, however, that, in any case, all costs of shipping, if necessary, are paid by you, the purchaser.

**THE WARRANTY REGISTRATION CARD SHOULD BE ACCURATELY COMPLETED AND MAILED TO AND RECEIVED BY PEAVEY WITHIN FOURTEEN (14) DAYS FROM THE DATE OF YOUR PURCHASE.**

In order to obtain service under these warranties, you must:

- Bring the defective item to any AUTHORIZED PEAVEY DEALER or AUTHORIZED PEAVEY SERVICE CENTER and present therewith the ORIGINAL PROOF OF PURCHASE supplied to you by the AUTHORIZED PEAVEY DEALER in connection with your purchase from him of this product.

If the DEALER or SERVICE CENTER is unable to provide the necessary warranty service you will be directed to the nearest other PEAVEY AUTHORIZED DEALER or AUTHORIZED PEAVEY SERVICE CENTER which can provide such service.

**OR**

- Ship the defective item, prepaid, to:

PEAVEY ELECTRONICS CORPORATION  
International Service Center  
Highway 80 East  
MERIDIAN, MS 39301

including therewith a complete, detailed description of the problem, together with a legible copy of the original PROOF OF PURCHASE and a complete return address. Upon Peavey's receipt of these items:

If the defect is remedial under these limited warranties and the other terms and conditions expressed herein have been complied with, Peavey will provide the necessary warranty service to repair or replace the product and will return it, FREIGHT COLLECT, to you, the purchaser.

Peavey's liability to the purchaser for damages from any cause whatsoever and regardless of the form of action, including negligence, is limited to the actual damages up to the greater of \$500.00 or an amount equal to the purchase price of the product that caused the damage or that is the subject of or is directly related to the cause of action. Such purchase price will be that in effect for the specific product when the cause of action arose. This limitation of liability will not apply to claims for personal injury or damage to real property or tangible personal property allegedly caused by Peavey's negligence. Peavey does not assume liability for personal injury or property damage arising out of or caused by a non-Peavey alteration or attachment, nor does Peavey assume any responsibility for damage to interconnected non-Peavey equipment that may result from the normal functioning and maintenance of the Peavey equipment.

**UNDER NO CIRCUMSTANCES WILL PEAVEY BE LIABLE FOR ANY LOST PROFITS, LOST SAVINGS, ANY INCIDENTAL DAMAGES OR ANY CONSEQUENTIAL DAMAGES ARISING OUT OF THE USE OR INABILITY TO USE THE PRODUCT, EVEN IF PEAVEY HAS BEEN ADVISED OF THE POSSIBILITY OF SUCH DAMAGES.**

THESE LIMITED WARRANTIES ARE IN LIEU OF ANY AND ALL WARRANTIES, EXPRESS OR IMPLIED, INCLUDING, BUT NOT LIMITED TO, THE IMPLIED WARRANTIES OF MERCHANTABILITY AND FITNESS FOR A PARTICULAR USE; PROVIDED, HOWEVER, THAT IF THE OTHER TERMS AND CONDITIONS NECESSARY TO THE EXISTENCE OF THE EXPRESS, LIMITED WARRANTIES, AS HEREINABOVE STATED, HAVE BEEN COMPLIED WITH, IMPLIED WARRANTIES ARE NOT DISCLAIMED DURING THE APPLICABLE ONE-YEAR OR NINETY-DAY PERIOD FROM DATE OF PURCHASE OF THIS PRODUCT.

SOME STATES DO NOT ALLOW LIMITATION ON HOW LONG AN IMPLIED WARRANTY LASTS, OR THE EXCLUSION OR LIMITATION OF INCIDENTAL OR CONSEQUENTIAL DAMAGES, SO THE ABOVE LIMITATIONS OR EXCLUSIONS MAY NOT APPLY TO YOU. THESE LIMITED WARRANTIES GIVE YOU SPECIFIC LEGAL RIGHTS, AND YOU MAY ALSO HAVE OTHER RIGHTS WHICH MAY VARY FROM STATE TO STATE.

THESE LIMITED WARRANTIES ARE THE ONLY EXPRESS WARRANTIES ON THIS PRODUCT, AND NO OTHER STATEMENT, REPRESENTATION, WARRANTY OR AGREEMENT BY ANY PERSON SHALL BE VALID OR BINDING UPON PEAVEY.

In the event of any modification or disclaimer of express or implied warranties, or any limitation of remedies, contained herein conflicts with applicable law, then such modification, disclaimer or limitation, as the case may be, shall be deemed to be modified to the extent necessary to comply with such law.

Your remedies for breach of these warranties are limited to those remedies provided herein and Peavey Electronics Corporation gives this limited warranty only with respect to equipment purchased in the United States of America.

#### **INSTRUCTIONS — WARRANTY REGISTRATION CARD**

1. Mail the completed WARRANTY REGISTRATION CARD to:

PEAVEY ELECTRONICS CORPORATION  
POST OFFICE BOX 2898  
MERIDIAN, MISSISSIPPI 39302-2898

- a. Keep the PROOF OF PURCHASE. In the event warranty service is required during the warranty period, you will need this document. **There will be no identification card issued by Peavey Electronics Corporation.**
2. **IMPORTANCE OF WARRANTY REGISTRATION CARDS AND NOTIFICATION OF CHANGES OF ADDRESS:**
    - a. Completion and mailing of WARRANTY REGISTRATION CARDS — Should notification become necessary for any condition that may require correction, the REGISTRATION CARD will help ensure that you are contacted and properly notified.
    - b. Notice of address changes — If you move from the address shown on the WARRANTY REGISTRATION CARD, you should notify Peavey of the change of address so as to facilitate your receipt of any bulletins or other forms of notification which may become necessary in connection with any condition that may require dissemination of information or correction.
  3. You may contact Peavey directly by telephoning (601) 483-5365.
  4. Please have the Peavey product name and serial number available when communicating with Peavey Customer Service.



**PEAVEY ELECTRONICS CORPORATION**/711 A Street/Meridian, MS 39302-2898/U.S.A./Telephone: (601) 483-5365/Fax: (601) 484-4278/Telex: 504115  
#80300816 ©1988 Printed in U.S.A.