

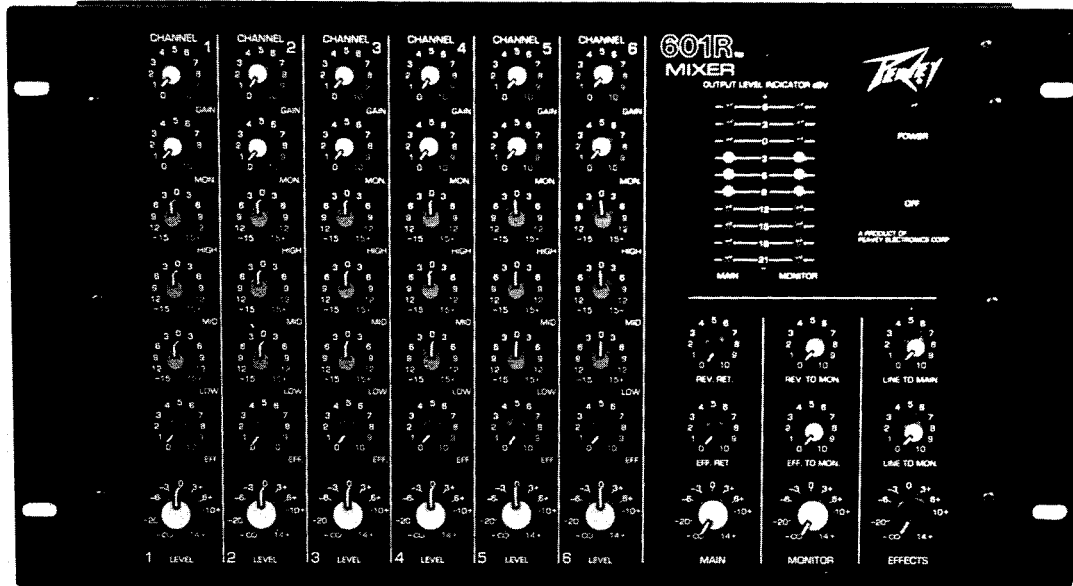

# 601R MIXER

## OPERATING GUIDE

**CAUTION**  
TO PREVENT ELECTRICAL SHOCK OR FIRE HAZARD, DO NOT EXPOSE THIS INSTRUMENT TO RAIN OR MOISTURE.  
BEFORE USING THIS INSTRUMENT READ BACK COVER FOR FURTHER WARNINGS.



### INTRODUCTION

The system you have purchased is a very portable package with the flexibility of mixers twice the size at twice the price. The 601R™ features six channels, excellent 3-band equalization and rack mount versatility.

Rack mountable mixers have a special place in sound reinforcement applications, and many times no other type product will suffice. The 601R™ requires a very low profile, vertical mounting space, and is exceptionally thin, front to back. These dimensions are critical as rack space is usually a premium consideration. The input circuitry has tremendous dynamic range and will handle sound reinforcement applications with ease. As you read the enclosed literature, please try to learn as much as possible about the product so your job of sound reproduction will be easier and the results will be an overall improved performance. The person doing sound or installing sound systems is actually an extension of the performance and should master the sound equipment, just as a musician masters his/her instrument.

### INPUT GAIN CONTROL

The input gain control determines the sensitivity of each individual channel. It should be adjusted accordingly to each instrument or vocal that is being patched into this system. The operator must adjust the input gain so that overload "clipping" is avoided at the input. A very strong signal coming into the mixer would require a fairly low setting of the input gain control, and obviously, a very weak signal will require a fairly high setting of this control. Proper adjustment of the input gain control may be easily accomplished by setting up the highest expected input signal level and adjusting the input gain so that no "clipping" or distortion is heard from the amp/speaker system. After this mixer has been used several times, the operator will have a very good idea of the signal levels encountered and will be able to set up the input sensitivity with no difficulty. Please be aware that different types of microphones will have different output levels and different performers will get widely varying signals from microphones depending on the strength of their voices and/or their basic microphone technique.

### MONITOR SEND CONTROL

The monitor send control is the channel mixing element for determining the all important monitor mix. The signal for the monitor send is obtained right after the input preamp and before the channel EQ. This type control is referred to as a pre-monitor send, i.e. it is before or pre to the channel equalization and channel level control. This makes the control independent of all equalization and channel level adjustments. Alterations to channel EQ will not affect the equalization of the monitor system. Having the monitor send with pre-capability is absolutely vital to avoid feedback of the monitor system when various channel adjustments are made to the outfront system.

### HIGH FREQUENCY EQ CONTROL

The high frequency control is capable of 15 dB boost or cut at 8 KHz with a shelving characteristic sloping down to the crossover point. High frequency boost is obtained with a clockwise rotation of this control and counter clockwise rotation results in a cutting of the high frequencies. Flat response is obtained in the center (12:00) position. This flat "12:00" position is an excellent place to begin tuning the system so that with different rooms and concert halls you will be able to determine what degree of equalization is needed and then adjust accordingly.

### MID FREQUENCY EQ CONTROL

The mid control is capable of 15 dB boost or cut at 600 Hz with a peak/notch type filter response. This middle EQ circuit enables control over the vital mid-range frequencies. The action of this middle filter is somewhat different than the high and low EQ since it is of the peaking and notching type. This type of filter response is necessary to avoid undue interaction with the high and low equalizers. Caution must be exercised in order to avoid overboosting or overcutting the mid-range. Experience has proven that for most applications, a very slight mid-range cut tends to produce a tight and well defined sound. Generally, larger amounts of mid-range boost are extremely unpleasant and will probably never be used except for special effects or to correct extremely marginal microphones or unusual voice timbre. Most systems tend to get "muddy" and lose a certain amount of presence when excessive amounts of mid-range are used. More feedback problems are usually encountered when too much mid-range boost is used with sound reinforcement systems.

### LOW FREQUENCY EQ CONTROL

This control is capable of 15 dB boost or cut at 60 Hz and demonstrates a shelving characteristic so that excessive lows are not boosted below the usable range of sound reinforcement speaker systems. The shelving action of this circuit has proven to yield much more satisfying and effective equalization characteristics than some of the wide open EQ circuits claiming 20 to 25 dB boost and cut. Care should be taken with the low frequency control to not overboost lows on any particular instrument or vocal due to the fact that tremendous amounts of power amp "headroom" will be used up and a general "muddiness" will be apparent in the speaker system. Woofers may also be blown much more easily with excessive low frequency boost.

### EFFECTS SEND CONTROL

The effects send control is the channel control for determining the amount of signal from each respective channel to be sent to the effects output on the rear panel and simultaneously provides the drive signal for the internal reverb system. The effects send has been designed to provide multiple functions which will be explained further in the master control section. Please note: When reverb and external effects are to be used, the send control must function as the level regulating device for both internal reverb and the effects.

### CHANNEL LEVEL CONTROL

The channel level control determines the overall mix from all six channels that appears in the main master summing bus. This control should be operated near the zero dB indication (unity gain) whenever possible for optimum headroom and signal to noise. Operation of this control above the zero point increases system gain (and noise), and below the zero point sacrifices headroom. Please notice that this control is capable of 14 dB of gain above the (0) unity gain position. Proper adjustment of the input gain control will, in most cases, allow this level control to be operated very near the unity gain position.

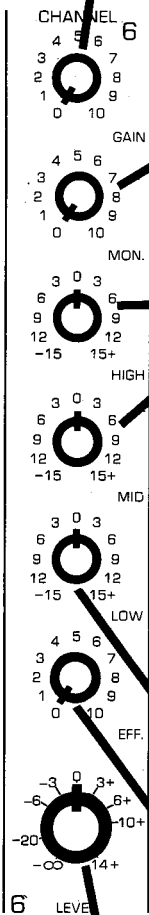

## MASTER SECTION

### MASTER (MAIN) LEVEL CONTROL

This control is the element that determines the overall level of the main outfront system. It is a master function and controls the level of the overall mix which has been established by the channel level controls. This function should be operated near the zero unity gain position for optimum performance. Above the zero position will yield increased noise and below the zero position will sacrifice headroom. The action of this control is very similar to the channel level controls and should present no problem in operation. Please notice that this control is capable of 14 dB of gain above the zero position.

### MASTER MONITOR CONTROL

Operation of this control is similar to that of the main level control and should be set in conjunction with the respective individual channel monitor send controls to achieve operation somewhere within the middle rotation of the master control. The action of this control is conventional and should present no operational difficulties. The output signal from the monitor master is available from the output connectors on the rear panel. Again, under normal usage, these controls should also be operated near the center of their range to allow optimum performance. Please notice this control is capable of 14 dB of gain above the zero position.

### EFFECTS MASTER CONTROL

The effects master control is the final control element determining the output level from the effects send jack on the rear panel, as well as the amount of reverb drive delivered to the internal reverberation system. Please note that no reverberation effect may be achieved unless the individual channel effects send controls and the effects level control are adjusted properly.

### EFFECTS RETURN CONTROL

The effects return control may be considered an auxiliary input channel with a high impedance input and has been designed to accept a wide range of audio signals. This effects control adjusts the level of the "return" signal back into the main mix.

### REVERB RETURN CONTROL

The reverb return control determines the amount of delay (reverb) signal blended back into the main mix.

### EFFECTS TO MONITOR CONTROL

The effects to monitor control enables signals from the effects return input to be routed back into the monitor mix. This unique feature enables external effects such as echo units, flangers, delay lines, etc. to be blended back into the monitor output signal if desired.

### REVERB TO MONITOR CONTROL

This unique circuit of the 601R™ Mixer allows mixing of the reverberation signal back into the monitor mix for those who do not prefer a "dry" monitor sound. (Note: Feedback may be more pronounced with reverb on the monitors.)

### LINE TO MAIN

This control functions with the phono line inputs provided at the rear panel to allow a signal patched in at this point to be mixed with the main signal from the other six channels of this mixer. (See rear panel description of line inputs.)

### LINE TO MONITOR

This control functions exactly like the line to main control and allows a signal which is patched into the phono line inputs at the rear panel to be mixed in with the monitor signal. (See rear panel description for line inputs.)

### POWER SWITCH/PILOT LED

The power switch is of the simple 2-position "rocker" type with the pilot LED immediately above it. Operation of this switch is conventional and should present no problems in operation. The "on" position will be indicated when the LED pilot light glows, signifying power is being delivered to the mixer circuitry.

### OUTPUT LEVEL INDICATION

Two 10-segment multicolored LED arrays have been provided to visually indicate the output level of the main and monitor mixes. The LED ladders indicate output levels from -21 dBV to +6 dBV. Each output section is capable of +18 dBV so there is 12 dB of headroom left when the top LED flashes for the mains and the monitors.

601R™  
MIXER

OUTPUT LEVEL INDICATOR dBV

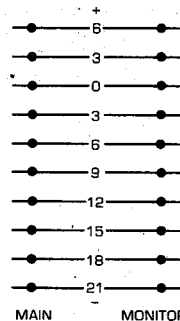

PEAVEY®

POWER



OFF

A PRODUCT OF  
PEAVEY ELECTRONICS CORP.

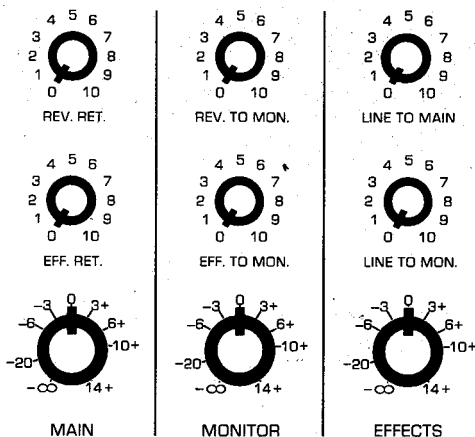

# REAR PANEL

## REAR PANEL INPUT SECTION

The rear panel of the 601R™ Mixer contains all the interface connection to and from the electronic circuitry. The versatility offered by these connections is unmatched by any competing unit and a thorough understanding of the various features is **essential** in order to fully realize the performance and versatility of this unit.

Each channel features both balanced (symmetrical) low impedance (600 ohms) as well as high impedance (50 K ohms) unbalanced inputs. Each of these inputs feature extremely wide dynamic range and are fully transient protected to ensure durability under road conditions. While these inputs are intended primarily for low or high impedance microphones, they will also work well for many other types of program sources.

## OUT/IN JACK

The 601R™ features a "stereo" out/in jack on each channel to facilitate the use of direct outputs/inputs from the preamps for "patching" various auxiliary units (chorus, flanging, tape/digital/analog delays, equalizers, etc.) "inline." To utilize this unique system, a stereo plug (ring/tip/sleeve) to a "Y" cord must be used. The tip portion of the 1/4" stereo jack serves as the channel send (output) while the ring portion will return the processed signal to the channel. The "sleeve" portion serves as the ground.

Since this is a stereo jack configuration, the first "click" on the jack may be used as a "pre-EQ" output with a mono 1/4" plug if desired. This first "click" **will not** disturb the signal flow to the remainder of the channel as it is fed into the master section. NOTE: IF THE SECOND "CLICK" OF THE OUT/IN JACK IS UTILIZED WITHOUT RETURNING ANY SIGNAL TO THE CHANNEL FROM AN EFFECTS DEVICE **THE REMAINING PREAMP FUNCTIONS WILL BE DISABLED.**

## AUXILIARY INPUTS

The auxiliary inputs are line level access points to the three internal mixing busses. They are the medium impedance type (33K ohms) and are provided to allow parallel mixers or for any other purpose that requires direct signal injection into the internal mixing busses of the 601R™.

## LINE CORD

For your safety, we have incorporated a 3-wire line (mains) cable with proper grounding facilities.

## REVERB FOOTSWITCH

To facilitate remote control of the reverberation function, we have included a remote control footswitch jack. Any standard single pole footswitch may be used to remotely defeat the reverb function. Please note that this switch disables the reverb system **only** and has no effect whatsoever on the effects system.

## LINE INPUTS

The line input features phono jacks and allows a signal to be patched directly into the "line to main" and "line to monitor" controls in the master section. These line inputs are extremely useful when a tape deck needs to be patched into the system without tying up a desperately needed channel input. Please note that RIAA equalization is not built into this input. Also note that the dual phono jacks are "bridged" (parallel) allowing a "stereo" signal to be patched in. Naturally, the "bridging" reduces this signal to mono.

## EFFECTS RETURN

The effects return input on the rear panel may be considered an auxiliary channel featuring its own set of level controls located on the front panel. This effects return is capable of handling a wide range of input signals and is a very high impedance type (220K ohms). The effects return system feeds into both main and monitor mixing busses through the respective controls and is intended for use when returning signals from external devices to be mixed into the main or monitor outputs.

## MAIN AND MONITOR OUTPUTS

The main and monitor outputs are located on the rear panel and are low Z unbalanced. The jacks are 1/4" phone and each output is capable of 8 volts (18 dBV) out. For sound reinforcement situations, the main output should patch to the power amp/speaker system for the main PA. The monitor output should patch to the power amp/speaker system that is used for monitors. (See patch diagram.)

# REAR PANEL

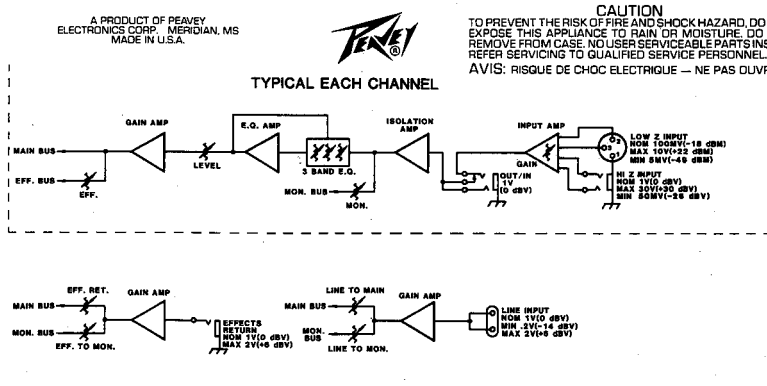
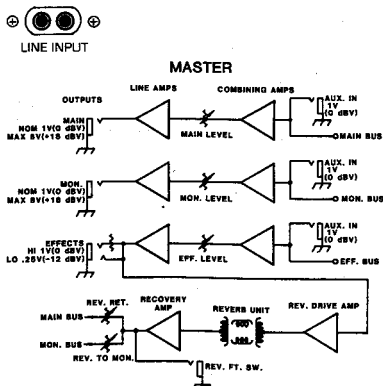
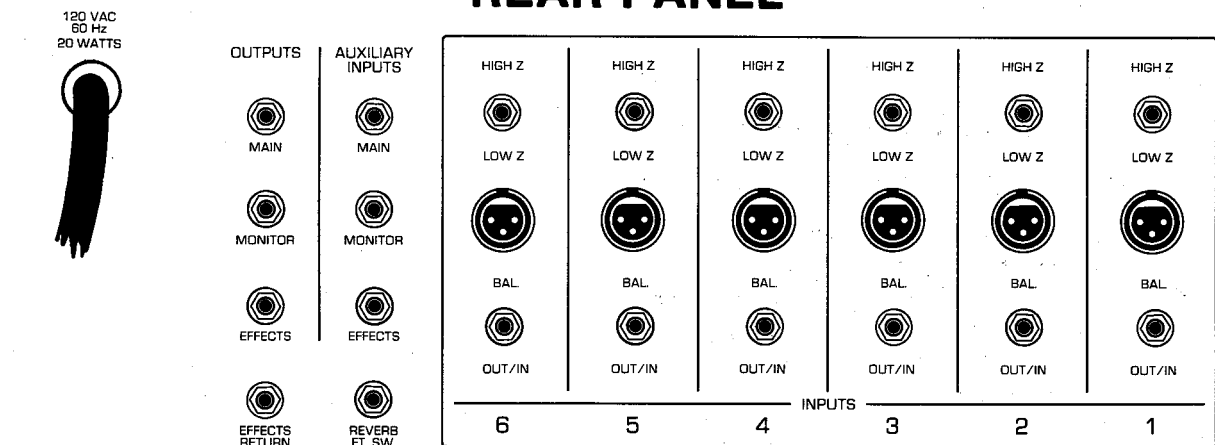

# PATCHING DIAGRAM

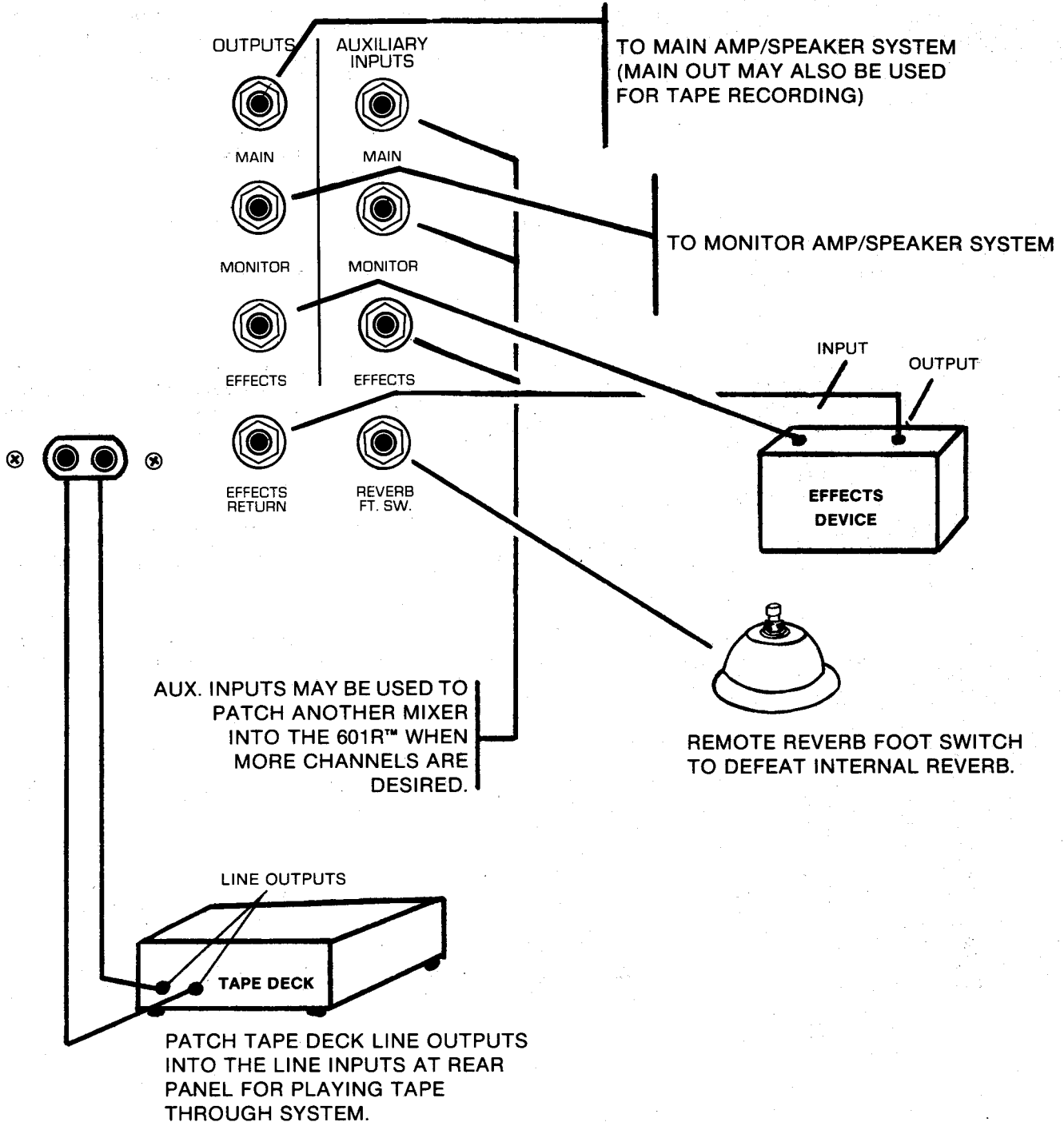

# SPECIFICATIONS

## SUMMARY OF FUNCTIONS:

6 ch in, main out, pre monitor, post effects (hi/low level) out; 3 band eq. each channel; master effects and reverb return to main and monitor; dual LED ladders; line input to main and monitor

## INPUTS, EACH CHANNEL:

1 low Z balanced microphone; 1 high Z unbalanced line; 1 high Z unbalanced (stereo ring) pre return

## INPUTS, MASTER:

1 high Z unbalanced auxiliary each for main, monitor, and effects, 1 high Z unbalanced effects return; dual (bridged) phono high Z line inputs (No RIAA)

## OUTPUTS, EACH CHANNEL:

1 low Z unbalanced (stereo tip) pre send

## OUTPUTS, MASTER:

1 low Z unbalanced line each for main, monitor, and (high/low level) effects; reverb footswitch

## CHANNEL MICROPHONE INPUTS:

Mic Impedance: Low Z 600 ohms balanced  
Nominal Input Level: -18 dBm, 100 mV RMS  
Minimum Input Level: -44 dBm, 5 mV RMS  
Maximum Input Level: +22 dBm, 10 Volts RMS

## CHANNEL LINE (HIGH Z MIC) INPUTS:

Line Impedance: Hi Z 10K ohms unbalanced  
Nominal Input Level: 0 dBV, 1 V RMS  
Minimum Input Level: -20 dBV, 0.1 V RMS  
Maximum Input Level: +30 dBV, 30 Volts RMS  
**CHANNEL RETURNS AND AUXILIARY INPUTS:**

Line Impedance: Hi Z 20K ohms unbalanced  
Designed Input Level: 0 dBV, 1 Volt RMS

## LINE & EFFECTS RETURN INPUTS:

Line Impedance: Hi Z 100K ohms unbalanced  
Nominal Input Level: 0 dBV, 1 VRMS  
Minimum Input Level: -14 dBV, 0.2 VRMS  
Maximum Input Level: +6 dBV, 2 VRMS

## MAIN, MONITOR & EFFECTS (HIGH LEVEL) UNBALANCED OUTPUTS:

Load Impedance: 600 ohms or greater  
Nominal Output: 0 dBV, 1 V RMS  
Maximum Output: +18 dBV, 8 VRMS into 50K ohms load; +16 dBm, 5 VRMS into 600 ohms load  
**EFFECTS (LOW LEVEL) UNBALANCED OUTPUT:**

Load Impedance: 10K ohms or greater  
Nominal Output: -12 dBV, 0.25 VRMS  
Maximum Output: +6 dBV, 2 VRMS

The following specs measured with a nominal input gain setting of 14 dB all channels, all levels

set at 0 dB, all EQ. set flat, all Lo Z inputs terminated with 600 ohms, all Hi Z inputs and all outputs terminated with 47K ohms.

## FREQUENCY RESPONSE:

(Any in/out combination with 1 VRMS output) 0, -2 dB, 20 Hz to 30 KHz

## SYSTEM HUM & NOISE:

(All channels on)  
-84 dBV (Hi Z line inputs)  
-80 dBV (Lo Z mic inputs)

## EQUIVALENT INPUT NOISE:

(20 Hz - 20 KHz, 150 ohms) -126 dBV

## OVER-ALL DISTORTION:

(Any in/out combination, 20 Hz - 20 KHz VRMS) Less than .05% THD, TYP below .01%

## EQUALIZATION:

+/-15 dB 60 Hz & 8 KHz, shelving  
+/-15 dB 600 Hz, peak/notch

## MAX. AVAILABLE GAIN:

+14 dB main control  
+14 dB channel control  
+46 dB mic input control  
+74 dB total

## LED READOUT RANGE:

-21 to +6 dBV

## POWER REQUIREMENTS:

120 VAC, 60 Hz, 20 Watts (Domestic)

**DANGER**  
EXPOSURE TO EXTREMELY HIGH NOISE LEVELS MAY CAUSE A PERMANENT HEARING LOSS. INDIVIDUALS VARY CONSIDERABLY IN SUSCEPTIBILITY TO NOISE INDUCED HEARING LOSS. BUT NEARLY EVERYONE WILL LOSE SOME HEARING IF EXPOSED TO SUFFICIENTLY INTENSE NOISE FOR A SUFFICIENT TIME.

THE U.S. GOVERNMENT'S OCCUPATIONAL SAFETY AND HEALTH ADMINISTRATION (OSHA) HAS SPECIFIED THE FOLLOWING PERMISSIBLE NOISE LEVEL EXPOSURES:

### DURATION PER DAY IN HOURS

8  
6  
4  
3  
2  
1 1/2  
1  
1/2  
1/4 or less

### SOUND LEVEL dBA, SLOW RESPONSE

90  
92  
95  
97  
100  
102  
105  
110  
115

ACCORDING TO OSHA, ANY EXPOSURE IN EXCESS OF THE ABOVE PERMISSIBLE LIMITS COULD RESULT IN SOME HEARING LOSS.

EAR PLUGS OR PROTECTORS IN THE EAR CANALS OR OVER THE EARS MUST BE WORN WHEN OPERATING THIS AMPLIFICATION SYSTEM IN ORDER TO PREVENT PERMANENT HEARING LOSS IF EXPOSURE IS IN EXCESS OF THE LIMITS SET FORTH ABOVE. TO INSURE AGAINST POTENTIALLY DANGEROUS EXPOSURE TO HIGH SOUND PRESSURE LEVELS, IT IS RECOMMENDED THAT ALL PERSONS EXPOSED TO EQUIPMENT CAPABLE OF PRODUCING HIGH SOUND PRESSURE LEVELS SUCH AS THIS AMPLIFICATION SYSTEM BE PROTECTED BY HEARING PROTECTORS WHILE THIS UNIT IS IN OPERATION.

### CAUTION

THIS MIXING CONSOLE/PREAMP HAS BEEN DESIGNED AND CONSTRUCTED TO PROVIDE ADEQUATE SIGNAL VOLTAGES FOR PLAYING MODERN MUSIC. IMPROPER USE OF THE GAIN/EQUALIZATION CONTROLS AND/OR IMPROPER USE OF INTERNAL/EXTERNAL BUSES MAY CREATE CLIPPING (SQUARE WAVES) AND POSSIBLY CAUSE SURFACE DAMAGE TO THE LOUDSPEAKER SYSTEMS. WHEN OPERATING THE GAIN/EQUALIZATION CONTROLS IN THESE MAXIMUM POSITIONS IS THEREFORE, NOT RECOMMENDED. PLEASE BE AWARE THAT MAXIMUM POWER CAN BE OBTAINED WITH VERY LOW SETTINGS OF THE GAIN/EQUALIZATION CONTROLS IF THE INPUT SIGNAL IS VERY STRONG.

IT IS COMMON PRACTICE AMONG USERS OF SOUND REINFORCEMENT EQUIPMENT TO IDENTIFY THE INDIVIDUAL CHANNELS WITH A TAPE WHICH IS PLACED ABOVE OR BELOW THE ROW OF VOLUME FADERS. MANY TYPES OR BRANDS OF TAPE HAVE A VERY STRONG ADHESIVE WHICH CAN INHIBIT THE PAINT ON THE FACEPLATE AND ACTUALLY REMOVE THE PAINT WHEN THE TAPE IS REMOVED. WE STRONGLY RECOMMEND THAT SCOTCH TAPE NOT BE USED ON PAINTED SURFACES NOR ANY OTHER TAPE THAT IS NOT ESPECIALLY DESIGNED FOR SUCH APPLICATIONS. MEDIUM OR LIGHT ADHESIVE MASKING OR MIXER LABEL TAPE IS RECOMMENDED IF TAPE IS USED. ANY TAPE LEFT ON PAINTED SURFACE FOR EXTENDED PERIODS WILL BE DIFFICULT TO REMOVE. NEVER USE CLEAR OR SCOTCH TAPE FOR THESE APPLICATIONS.

1. Read all safety and operating instructions before using this product.
2. All safety and operating instructions should be retained for future reference.
3. Obey all cautions in the operating instructions and on the back of the unit.
4. All operating instructions should be followed.
5. This product should not be used near water, i.e. a bathtub, sink, swimming pool, wet basement, etc.
6. This product should be located so that its position does not interfere with its proper ventilation. It should not be placed flat against a wall or placed in a built-in enclosure that will impede the flow of cooling air.
7. This product should not be placed near a source of heat such as a stove, heater, radiator or another heat producing amplifier.
8. Connect only to a power supply of the type marked on the unit adjacent to the power supply cord.
9. Never break off the ground pin on the power supply cord. For more information on grounding write for our free booklet "Shock Hazard and Grounding."
10. Power supply cords should always be handled carefully. Never walk or place equipment on power supply cords. Periodically check cords for cuts or signs of stress, especially at the plug and the point where the cord exits the unit.
11. The power supply cord should be unplugged when the unit is to be unused for long periods of time.
12. Metal parts can be cleaned with a damp rag. The vinyl covering used on some units can be cleaned with a damp rag, or an ammonia based household cleaner if necessary.
13. Care should be taken so that objects do not fall and liquids are not spilled into the unit through the ventilation holes or any other openings.
14. This unit should be checked by a qualified service technician if:
  - A. The power supply cord or plug has been damaged.
  - B. Anything has fallen or been spilled into the unit.
  - C. The unit does not operate correctly.
  - D. The unit has been dropped or the enclosure damaged.
15. The user should not attempt to service this equipment. All service work should be done by a qualified service technician.

Due to our efforts for constant improvement, features and specifications are subject to change without notice.



PEAVEY ELECTRONICS CORPORATION  
711 A Street / Meridian, MS 39301 / U.S.A.