

# PARTS AND OPERATION MANUAL



## PLASTER / MORTAR MIXERS

**WM-900S**

**WM-900P**

© COPYRIGHT 2001, MULTIQIP INC.

Revision #7 (03/17/06)



**MULTIQIP INC.**

18910 WILMINGTON AVE.  
CARSON, CALIFORNIA 90746  
310-537-3700  
800-421-1244  
FAX: 310-537-3927

**PARTS DEPARTMENT:**

800-427-1244  
FAX: 800-672-7877

**SERVICE DEPARTMENT/TECHNICAL ASSISTANCE:**

800-478-1244  
FAX: 310-631-5032

E-mail: [mq@multiquip.com](mailto:mq@multiquip.com) • [www.multiquip.com](http://www.multiquip.com)



# **WARNING**



## **CALIFORNIA — Proposition 65 Warning**

Diesel engine exhaust and some of its constituents are known to the State of California to cause cancer, birth defects and other reproductive harm.

## **HERE'S HOW TO GET HELP**

*PLEASE HAVE THE MODEL AND SERIAL NUMBER  
ON-HAND WHEN CALLING*

### ***PARTS DEPARTMENT***

*800-427-1244 or 310-537-3700*

*FAX: 800-672-7877 or 310-637-3284*

### ***SERVICE DEPARTMENT/TECHNICAL ASSISTANCE***

*800-478-1244 or 310-537-3700*

*FAX: 310- 537-4259*

### ***WARRANTY DEPARTMENT***

*888-661-4279, or 310-661-4279*

*FAX: 310- 537-1173*

### ***MAIN***

*800-421-1244 or 310-537-3700*

*FAX: 310-537-3927*

Here's How To Get Help ..... 3  
Table of Contents ..... 4  
Parts Ordering Procedures ..... 5  
Rules for Safe Operation & Safety Decals ..... 6  
Warranty ..... 7

**WHITEMAN — 900S & 900P**

Operations ..... 8-10  
Specifications ..... 11  
Explanation Of Codes In Remarks Column ..... 12  
Suggested Spare Parts ..... 13  
Drum Head Assembly ..... 14-15  
Paddle Shaft Assembly ..... 16-17  
Steel Drum (S) ..... 18-19  
Polyethylene Drum (P) ..... 20-21  
Gas Engines, Pulleys & Cab Assembly ..... 22-23  
Electric Motor & Pulleys ..... 24-25  
Axle & Wheel Group ..... 26-27

Terms and Conditions Of Sale — Parts ..... 28

*NOTE: Specification and part number  
are subject to change without notice.*

www.multiquip.com

**Ordering parts has never been easier!  
Choose from three easy options:**



**Order via Internet (Dealers Only):**

Order parts on-line using Multiquip's SmartEquip website!

- View Parts Diagrams
- Order Parts
- Print Specification Information



If you have an MQ Account, to obtain a Username and Password, E-mail us at: [parts@multiquip.com](mailto:parts@multiquip.com).

To obtain an MQ Account, contact your District Sales Manager for more information.

Goto [www.multiquip.com](http://www.multiquip.com) and click on **Order Parts** to log in and save!

Use the **internet** and qualify for a **5% Discount** on *Standard orders* for all orders which include complete part numbers.\*

Note: Discounts Are Subject To Change



**Order via Fax (Dealers Only):**

All customers are welcome to order parts via Fax.

**Domestic (US) Customers dial:**  
1-800-6-PARTS-7 (800-672-7877)

**Fax** your order in and qualify for a **3% Discount** on *Standard orders* for all orders which include complete part numbers.\*

Note: Discounts Are Subject To Change



**Order via Phone: Domestic (US) Dealers Call:**  
1-800-427-1244

**Non-Dealer Customers:**

Contact your local Multiquip Dealer for parts or call 800-427-1244 for help in locating a dealer near you.



**International Customers** should contact their local Multiquip Representatives for Parts Ordering information.

**When ordering parts, please supply:**

- |  |   |  |   |                                       |   |                                 |  |                                   |  |   |  |
|--|---|--|---|---------------------------------------|---|---------------------------------|--|-----------------------------------|--|---|--|
| <ul style="list-style-type: none"> <li><input type="checkbox"/> Dealer Account Number</li> <li><input type="checkbox"/> Dealer Name and Address</li> <li><input type="checkbox"/> Shipping Address (if different than billing address)</li> <li><input type="checkbox"/> Return Fax Number</li> <li><input type="checkbox"/> Applicable Model Number</li> <li><input type="checkbox"/> Quantity, Part Number and Description of Each Part</li> </ul> | <ul style="list-style-type: none"> <li><input type="checkbox"/> Specify Preferred Method of Shipment:                     <table border="0" style="margin-left: 20px;"> <tr> <td><input checked="" type="checkbox"/> Fed Ex/UPS</td> <td><input checked="" type="checkbox"/> DHL</td> </tr> <tr> <td><input type="checkbox"/> Priority One</td> <td><input checked="" type="checkbox"/> Truck</td> </tr> <tr> <td><input type="checkbox"/> Ground</td> <td></td> </tr> <tr> <td><input type="checkbox"/> Next Day</td> <td></td> </tr> <tr> <td><input type="checkbox"/> Second/Third Day</td> <td></td> </tr> </table> </li> </ul> | <input checked="" type="checkbox"/> Fed Ex/UPS | <input checked="" type="checkbox"/> DHL | <input type="checkbox"/> Priority One | <input checked="" type="checkbox"/> Truck | <input type="checkbox"/> Ground |  | <input type="checkbox"/> Next Day |  | <input type="checkbox"/> Second/Third Day |  |
| <input checked="" type="checkbox"/> Fed Ex/UPS   | <input checked="" type="checkbox"/> DHL   |  |   |                                       |   |                                 |  |                                   |  |   |  |
| <input type="checkbox"/> Priority One  | <input checked="" type="checkbox"/> Truck   |  |   |                                       |   |                                 |  |                                   |  |   |  |
| <input type="checkbox"/> Ground  |   |  |   |                                       |   |                                 |  |                                   |  |   |  |
| <input type="checkbox"/> Next Day  |   |  |   |                                       |   |                                 |  |                                   |  |   |  |
| <input type="checkbox"/> Second/Third Day  |   |  |   |                                       |   |                                 |  |                                   |  |   |  |

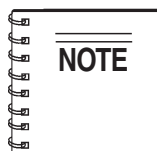

Unless otherwise indicated by customer, all orders are treated as *Standard Orders* and will ship within 24 hours. We will make every effort to ship *Air Shipments* the same day the order is received, if received prior to 2PM PST. *Stock Orders* must be noted on fax or web order form.

**WE ACCEPT ALL MAJOR CREDIT CARDS!**



# RULES FOR SAFE OPERATION & SAFETY DECALS



■ Do not operate or service this equipment before reading the operating and maintenance instructions manual or serious injury may result.

■ Do not operate this equipment unless all guards and safety devices are attached and in place.

■ Stop the engine when leaving the equipment.

■ Block the unit when leaving or when using on a slope

■ Maintain this equipment in a safe operating condition at all times.

■ Caution must be exercised while servicing this equipment. Rotating and moving parts can cause injury if contacted.

■ Stop the engine before servicing, adding fuel and oil.



■ When towing, an adequate safety chain must be fastened to the frame, refer to page 9.

■ Keep all inexperienced and unauthorized people away from the equipment at all times.

■ Unauthorized equipment modifications will void all warranties.

■ Check all fasteners periodically for tightness. Also check towing tongue bolt, lock nut and wheel lug nuts for wear.

■ Wear safety glasses at all times when working around machinery.

■ Stop the engine and disconnect the spark plug before allowing anybody's hands in the mixing drum.

■ Never pour or spray water over the engine or electric motor.

■ Always stand clear of dump handle when mixer is in operation. Any binding of material between the mixer blades and drum will cause drum and handle to quickly move in the discharge position.



**The safety instruction decals shown must be on all Whiteman Mixers**



Caution Decal is:  
P/N EM948423

## WHITEMAN SAFETY INSTRUCTIONS

1. Read owners manuals before operating.
2. Keep unauthorized and untrained people away from machine during operation.
3. Make sure all safety devices are in place before this machine is started.
4. Make sure engine is turned off and spark plug wire is disconnected before cleaning the machine.
5. Keep hands and fingers away from moving objects.
6. Do not operate machine in an enclosed area. Proper ventilation is required.
7. Never leave machine unattended when operating.
8. Always stop engine and allow engine to cool before adding fuel or oil.

□□□□□□□ □□□□□□□ □□□□□□□ — □ □□□□□□□ □□□□□□□ — □□□□□□, □□□□□□□□□□

The safety instruction decal is P/N 924801

There are no warranties, express or implied, made by **Multiquip Inc.** hereunder on Products manufactured or distributed by it except the warranty against defects in material and workmanship on new Products to the original purchaser, as hereinafter set forth.

Multiquip Inc. warrants Products manufactured by it to be free from defects in material and workmanship under normal and proper use and servicing for the periods specified on the bottom of this page. Warranty on the engines supplied with the Products is limited to the warranty extended by the engine manufacturer. Multiquip Inc.' sole obligation under this warranty is limited to the replacement or repair, at its Carson, California facility, or such authorized facility, of only such part or parts thereof as shall appear to Multiquip Inc. upon inspection at such facility, to have been defective in material and workmanship.

A statement giving model and serial number of the Product, date of sale to original purchaser and date and description of failure shall accompany all parts.

Any part or parts determined by Multiquip Inc. to be defective will be replaced free of charge, F.O.B. Carson, California. Returned parts subject to warranty must be shipped prepaid to Multiquip Inc. within 30 days from the date the defective part or parts were removed. This warranty does not apply to any part or parts which have been subject to abuse or unauthorized repairs

Warranty with respect to Products, components and accessories not manufactured by Multiquip Inc. is limited to the warranty extended by the manufacturer of those items.

There are no warranties, express or implied, in addition to the above except as may be provided in writing by Multiquip Inc. MULTIQUIP INC. SHALL NOT BE LIABLE FOR ANY SPECIAL, INDIRECT OR CONSEQUENTIAL DAMAGES.

**THE FOREGOING WARRANTIES ARE IN PLACE AND IN LIEU OF ALL WARRANTIES OF MERCHANTABILITY AND FITNESS AND SETS FORTH THE ENTIRE OBLIGATION OF MULTIQUIP INC.**

To avoid misrepresentations with respect to Products sold hereunder, the Dealer agrees that no warranties, or other operating guaranties on any Products covered by this Agreement shall be made in excess of those made by Multiquip Inc.

### **Multiquip Inc. Warranty Periods:**

WM-900 ..... 12 months

# WM-900S, 900P — OPERATIONS

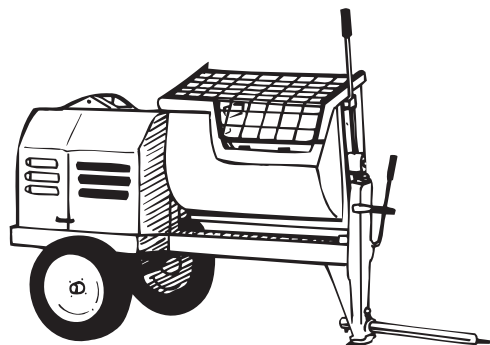

## GENERAL

The Whiteman WM-700 and WM-900 Series plaster and mortar mixers are quality mixers that have a batch capacity of 2.5 and 3.5 bags respectively. With proper care, they will give continuous service year-after-year.

## BEFORE STARTING

Before starting the engine, read the engine owners manual and thoroughly understand the safety information.

Check the items listed below:

**Oil Levels.** Be sure to check the oil levels in the engine and engine reduction unit before starting the unit.

**Hardware.** Check all hardware on the mixer before starting. Periodically inspect all hardware. Loose hardware can contribute to early component failure and poor performance. Use the torque chart below as a general guideline and keep all hardware tight:

HARDWARE DIA	TORQUE (LB./FT.)
5/16" - 18	14
#/8" - 16	24
#/8" - 24	37
1/2" - 13	39
1/2" - 13 (Grade 8)	90

## GASOLINE ENGINE CARE

For care and operation of the gasoline engine, refer to the engine manufacturer's operating instructions furnished with the engine. We recommend draining and refilling the engine crankcase at least every thirty hours of operation. Check the engine oil level daily.

## ELECTRIC MOTOR CARE

For lubrication care and operation of the electric motor, refer to your electric motor instruction booklet furnished with the motor.

Protect the electric motor from dust as much as possible and keep ventilating openings clean. Do not spray water on the electric motor.

Refer to the following chart. For recommend plug sizes.

MOTOR	115 VOLT 1Ø WM 700		230 VOLT 1Ø WM 900	
	PIGTAIL CAP NEMA/ WHITEMAN	CONN BODY NEMA/ WHITEMAN	PIGTAIL CAP NEMA/ WHITEMAN	CONN BODY NEMA/ WHITEMAN
1½ & 3 HP	L5-30P/940545	L5-30R/940546	L6-15P/940550	L6-15R/940551

## CONTROLS

**KILL SWITCH:** (Gasoline Engine Only) Located on the side of the engine cover.

**ENGINE THROTTLE AND CHOKE CONTROLS:** Please refer to the engine owners manual for specific instructions. The electric motor switch ( electric motor only) located on the motor — is used to start and stop the mixer.

**DUMP LATCH:** To dump the tub, grasp the dump handle and lift the dump latch, then rotate the tub to discharge the mix. After, discharge, return the tub to the vertical mixing position.

## CLUTCH

The paddle shaft and mixing blades are engaged and disengaged by tightening and loosening the drive belts with a spring loaded idler pulley. To engage the clutch, rotate the lever counterclockwise. The spring maintains the correct belt tension. To disengage the clutch, rotate the lever clockwise against the lever stop. The engine base is slotted to adjust for belt wear and to bring the idler pulley into operating range.

**CAUTION:** Stop the engine before allowing anybody to put their hands in the mixing drum.

## WHEEL BEARINGS

After every 3 months of operation, remove the hub dust cap and inspect the wheel bearings. Once a year, or when required, disassemble the wheel hubs remove the old grease and repack the bearings forcing grease between rollers, cone and cage with a good grade of high speed wheel bearing grease (never use grease heavier than 265 A.S.T.M. penetration ("No. 2.") Fill the wheel hub with grease to the inside diameter of the outer races and also fill the hub grease cap. Reassemble the hub and mount the wheel. Then tighten the adjusting nut, at the same time turn the wheel in both directions, until there is a slight bind to be sure all the bearing surfaces are in contact. Then back-off the adjusting nut ! / 6 to ¼ turn or to the nearest locking hole or sufficiently to allow the wheel to rotate freely within limits of .001" to .010" end play. Lock the nut at this position. Install the cotter pin and dust cap, and tighten all hardware.



## BEARING BRACKET

Grease the bearing bracket every month.

## COUNTERSHAFT

The countershaft rotates on two self-aligned pillow block bearings. Grease these every 40 hours using grade #1 Lithium Base grease.

## GEAR ALIGNMENT

The countershaft and driven pinion are mounted on a slotted base. To align gears, loosen the pillow block mounting bolts and move them until the necessary alignment has been made.

## GEAR LUBRICATION



The surface of the pinion and the bull gear should be very lightly greased every 250 hours.

**IMPORTANT! AVOID OVER-GREASING. EXCESS GREASE WILL ACCUMULATE CONTAMINATES AND CAUSE PREMATURE WEAR.**



### IMPORTANT — DRUM HEAD SEAL CARE

Grease seals every 40 hours of operation using any grade #1 lithium base grease. Apply grease until visible inside of mixing tub (overgrease). This will purge seal system of contamination.

## DRUM GRILL

The drum opening is covered by a steel grill that is hinged for easy cleaning. This grill should be closed at all times when mixer is in use. Do not remove the grill or grill opening bar. Keep the grill clean by washing it down daily.

**CAUTION:** Stop the engine before allowing anybody to put their hands in the mixing drum.

**TOWING — Before towing, check with local and state laws for proper compliance.**

The tow bar and chain must be properly attached to the mixer and towing vehicle prior to towing. Refer to the following installation instruction:

**Step 1.** Insert the Draw Bar into the main frame. Secure, utilizing the 3/4" bolt (grade 5) and nylock nut. Tighten to 100 foot pounds.

**Step 2.** Install the chain through the hole located between the frame gusset and frame angle. Loop the chain together and place under the Draw Bar. Secure with connector link.

**Step 3.** Extend the chain along the length of the Draw Bar, remove excess chain (slack) and secure to bottom connector link. Secure the chain to the towing vehicle, using the connector link.

**NOTE:** It is critical that the length of chain be properly adjusted to prevent the Draw Bar and front mixer stand from dropping to the ground (contact) in the event the Draw Bar becomes disconnected from the towing vehicle.

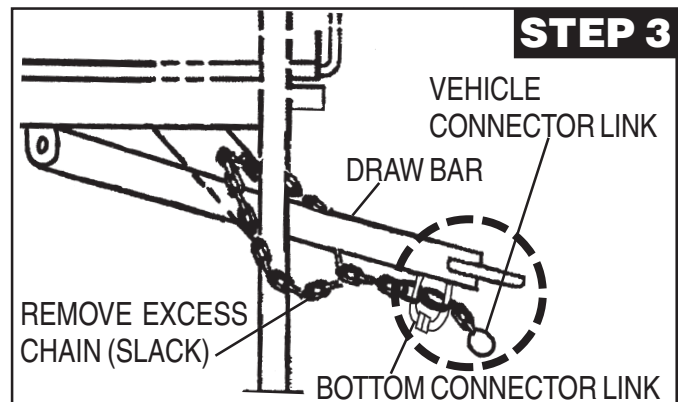
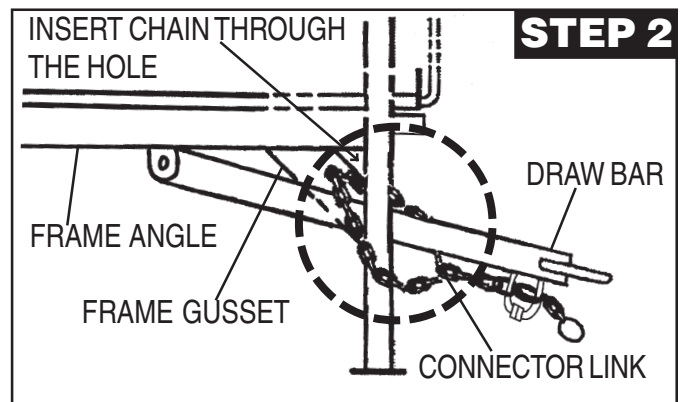
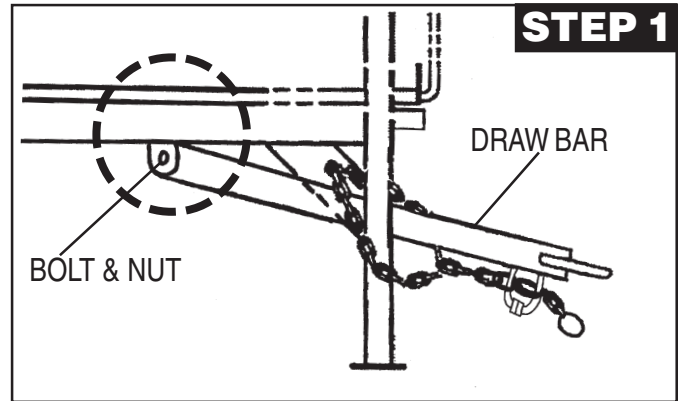

**SAFETY CHAIN** ..... P/N 3148

**CONNECTOR LINK** ..... P/N 01004

# WM-900S, 900P — OPERATIONS



**DANGER**



**BEFORE TOWING**

## BALL HITCH COUPLER

1. Check vehicle hitch, ball, and coupler for signs of wear or damage. Replace any parts that are worn or damaged before towing.
2. Use only the 2" ball diameter as indicated on your coupler. Use of any other ball diameter will create an extremely dangerous condition which can result in separation of the coupler and ball or ball failure.
3. Be sure the coupler is secured to the hitch ball and the lock lever is down tight and locked.  
Recheck tightness again after towing about 50 miles.
4. Check that trailer safety chains are properly connected.

## RECOMMENDED MAINTENANCE

1. Smear ball socket and clamp face with chassis grease. Periodically oil pivot points and solutions surfaces of coupler with SAE 30 wt. motor oil.
2. When parking or storing your trailer. Keep the coupler off the ground so dirt will not build up in the ball socket.



**DANGER**



**If housing is deformed, replace complete coupler.**

**USE ONLY GENUINE FULTON REPAIR KITS.**

## CLEANING — BLADE ADJUSTMENTS

Always disconnect the spark plug wire before cleaning the inside of the drum.

Never pour or spray water over the gasoline engine or electric motor.

For consistent performance, long life and high quality mixing, thoroughly clean the mixer inside and out at the end of each day's operation. To prevent lumps of dried mortar from forming and contamination of future batches, do not allow a buildup of materials to form on the blades or anywhere inside the drum.

The following is the recommended wiper blade adjustments:

## 1) STEEL DRUM MIXERS

### SIDE SCRAPER

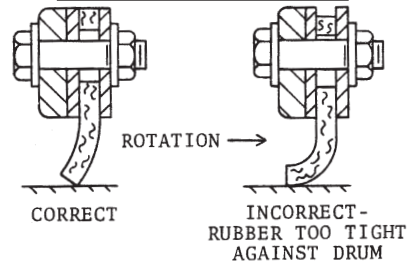

### END SCRAPER

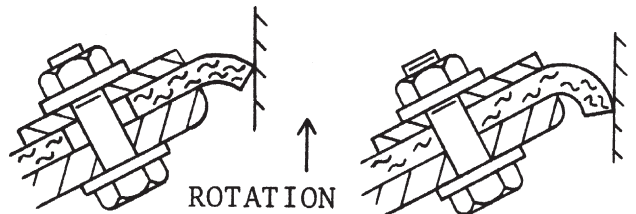

**CORRECT**

**INCORRECT -  
RUBBER TOO TIGHT  
AGAINST DRUM**

## 2) POLYETHYLENE DRUM MIXERS

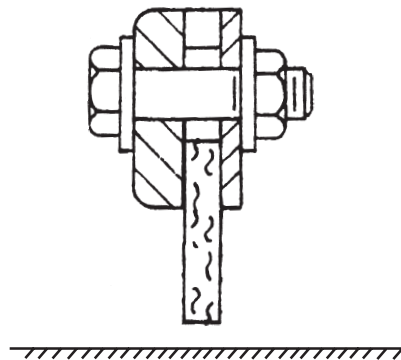

The poly blade should come as close as possible to the surface without touching. If material builds up on the drum, you may use a rubber mallet to dislodge the material without adverse effect to the drum.

### IMPORTANT NOTICE

**EPOXY COMPATIBILITY** — There are some epoxies and other chemicals used in certain applications that are not compatible with polyethylene tubs.

Since Whiteman Industries cannot control the end user's application of this product, we will not assume responsibility for the resulting damages when exposed to incompatible chemicals.

## WM-900S SPECIFICATIONS

<u>MODEL</u>	<u>U.S.(inch)</u>	<u>METRIC</u>
CAPACITY .....	9 CUBIC FEET .....	248 LITERS
BAG CAPACITY .....	2½ - 3½ .....	2½ - 3½
WEIGHT (APPROX.) .....	870 LBS. ....	395 KG.
L x W x H .....	71 x 50 x 59 IN. ....	180 x 127 x 150 CM.
LENGTH W/TOW BAR .....	98 IN. ....	248 CM.
HEIGHT W/DUMP HANDLE .....	77 IN. ....	195 CM.
DISCHARGE HEIGHT .....	21 IN. ....	53 CM.
DRIVE .....	V-BELT TO GEAR .....	—
DUMP ACTION .....	MANUAL .....	—

## WM-900P SPECIFICATIONS

<u>MODEL</u>	<u>U.S.(inch)</u>	<u>METRIC</u>
CAPACITY .....	9 CUBIC FEET .....	248 LITERS
BAG CAPACITY .....	2½ - 3½ .....	2½ - 3½
WEIGHT (APPROX.) .....	870 LBS. ....	395 KG.
L x W x H .....	71 x 50 x 59 IN. ....	180 x 127 x 150 CM.
LENGTH W/TOW BAR .....	98 IN. ....	248 CM.
HEIGHT W/DUMP HANDLE .....	77 IN. ....	195 CM.
DISCHARGE HEIGHT .....	21 IN. ....	53 CM.
DRIVE .....	V-BELT TO GEAR .....	—
DUMP ACTION .....	MANUAL .....	—

*NOTE: In accordance with our established policy of constant improvement, we reserve the right to amend these specifications at anytime without notice.*

# EXPLANATION OF CODE IN REMARKS COLUMN

How to read the marks and remarks used in this parts book.

## Section 1: Items Found In the “Remarks” Column

Serial Numbers-Where indicated, this indicates a serial number range (inclusive) where a particular part is used.

Model Number-Where indicated, this shows that the corresponding part is utilized only with this specific model number or model number variant.

## Section 2: Items Found In the “Remarks” Column

Serial Numbers-Where indicated, this indicates a serial number range (inclusive) where a particular part is used.

Model Number-Where indicated, this shows that the corresponding part is utilized only with this specific model number or model number variant.

## Section 3: Items Found In the “Items Number” Column

All parts with same symbol in the number column, \*, #, +, %, or ■, belong to the same assembly or kit.

Note: If more than one of the same reference number is listed, the last one listed indicates newest (or latest) part available.

### NOTE

If more than one of the same reference number is listed, the last one listed indicates newest (or latest) part available.

### NOTE

*The contents of this catalog are subject to change without notice.*

# WM-900S, 900P — SUGGESTED SPARE PARTS

## WM-900S/P

### 1 to 3 Units

Qty.	P/N	Description
3	EM505834	V-BELT
3	491115	V-BELT, w/ELECTRIC MOTOR
6	491010	LATCH ASSY
3	EM200863	BLADE KIT STEEL DRUM
3	EM204625	BLADE KIT POLY DRUM
2	EM902153	BEARING, DRUM HEAD
2	3131	O-RING, DRUM HEAD
2	3530	SEAL KIT
1	3351	PINION GEAR

## WM-900S/P

### 5+ Units

Qty.	P/N	Description
5	EM505834	V-BELT
5	491115	V-BELT, w/ELECTRIC MOTOR
10	491010	LATCH ASSY
5	EM200863	BLADE KIT STEEL DRUM
5	EM204625	BLADE KIT POLY DRUM
4	EM902153	BEARING, DRUM HEAD
4	3131	O-RING, DRUM HEAD
1	EM940734	SWITCH, ON/OFF
2	3351	DRIVEN PINON GEAR
1	509171	DUMP HANDLE, POLY DRUM
1	EM201537	DUMP HANDLE, STEEL DRUM
4	3530	SEAL KIT
2	3065	SEAL, AXLE
2	3469	DUST CAP AXLE
2	EM903049	BEARING CONE UP TO S/N HL60000
2	EM903113	BEARING CONE STARTING S/N JA00000
2	EM903012	BEARING CUP

#### NOTE

Part numbers on this Suggested Spare Parts List may supercede/replace the P/N shown in the text pages of this book.

# WM-900S, 900P — DRUM HEAD ASSEMBLY

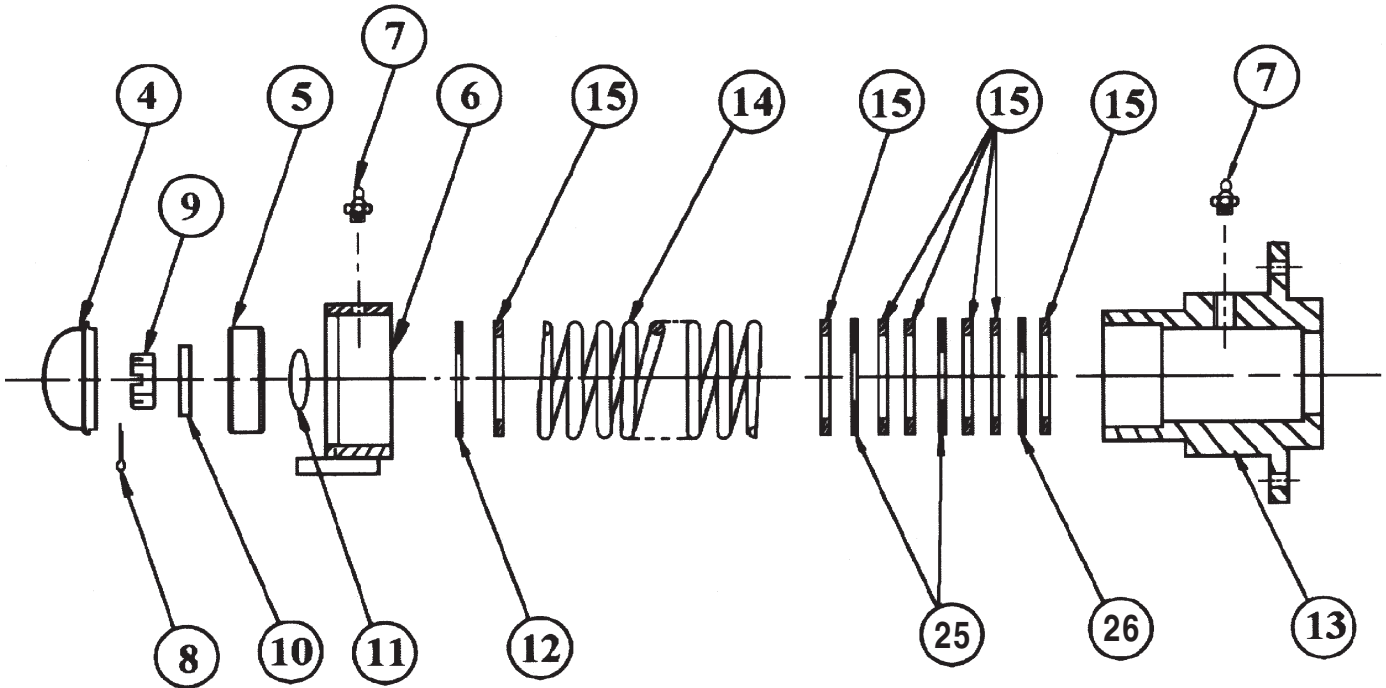

# WM-900S, 900P — DRUM HEAD ASSEMBLY

## DRUM HEAD ASSEMBLY

<u>NO.</u>	<u>PART NO.</u>	<u>PART NAME</u>	<u>QTY.</u>	<u>REMARKS</u>
2	EM200297	U-BOLT	2	
	EM968011	NUT HEX ½-13	4	
3	EM200292	U-BOLT INSERT	4	
4	3249	DUST CAP .....	1	REPLACES 50017
5	EM902153	BEARING	2	
6	500076	BRACKET, DUMP BEARING .....	2	S/N 750002 THRU 750179
6	EM507720	BRACKET, DUMP BEARING .....	2	S/N 750180 & UP
7	EM916019	GREASE ZERK .....	2	REPLACES 491705
8	5028 B	COTTER PIN 1/8 X 2 .....	2	REPLACES 491690
9	8164	CASTLE NUT .....	2	REPLACES 502246
10	3047	SPACER .....	2	REPLACES 500089
11	3131	O-RING .....	2	REPLACES 491040
12*	13002	SEAL .....	2	REPLACES 504749
13	3291	DRUM HEAD, BEARING BOSS .....	2	S/N 750002, THRU 750179 REPLACES 500085
13	507719	DRUM HEAD, BEARING BOSS .....	2	S/N 750180 & UP
14	3024	SPRING .....	2	REPLACES 491930
15	3061	THIN SEAL SPACER .....	14	REPLACES 500088
25*	3019	SEAL .....	4	REPLACES 500086
26*	3494	SEAL URETHANE .....	2	REPLACES 500613
	3530	SEAL KIT, PADDLE SHAFT .....	1	INCLUDES ITEMS w/*

# WM-900S, 900P — PADDLE SHAFT ASSEMBLY

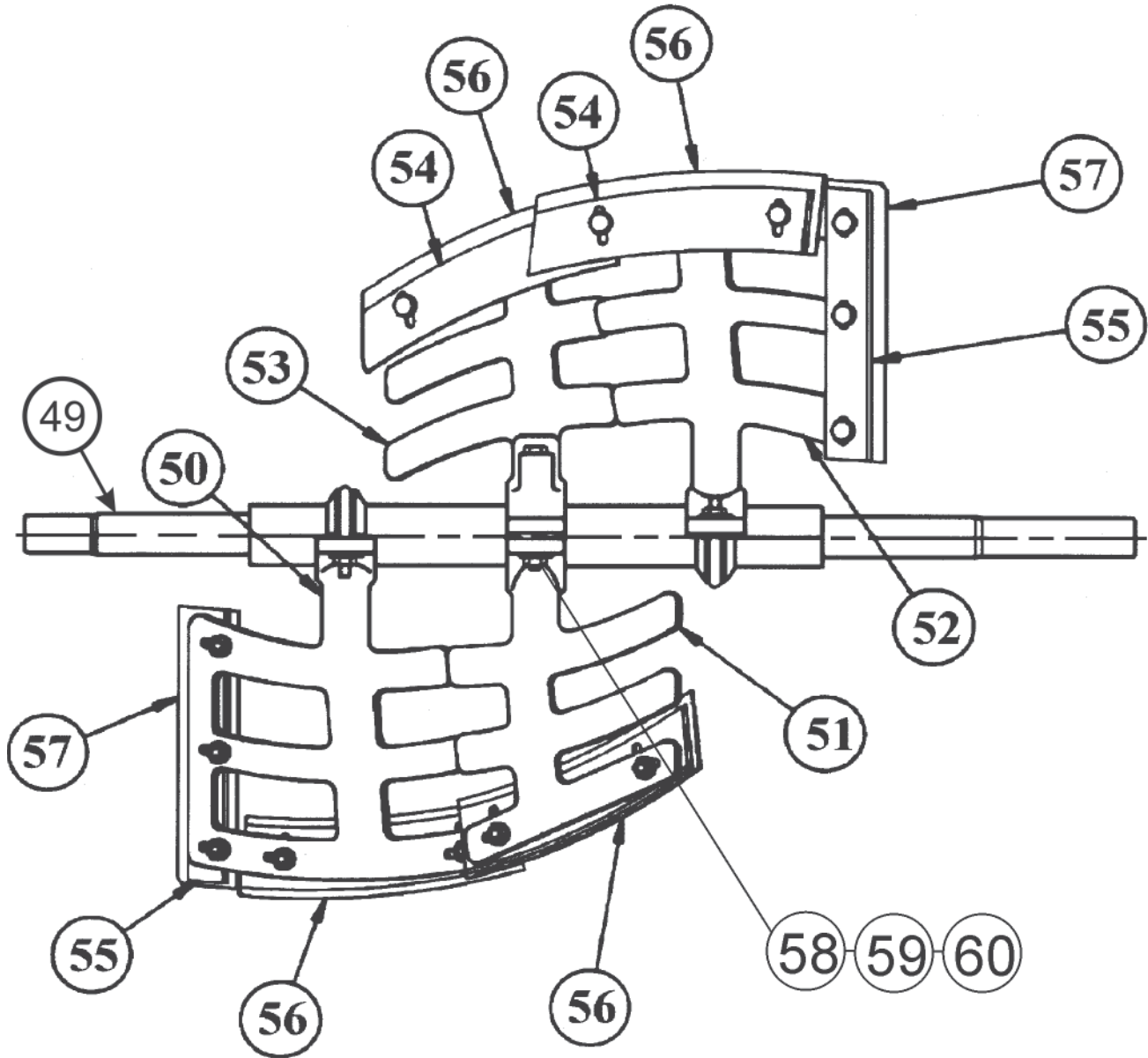



# WM-900S, 900P — PADDLE SHAFT ASSEMBLY

## PADDLE SHAFT ASSEMBLY

<u>NO.</u>	<u>PART NO.</u>	<u>PART NAME</u>	<u>QTY.</u>	<u>REMARKS</u>
46	EM200297	U-BOLT	2	
47	EM968011	NUT ½"-13	4	
48	EM200292	U-BOLT INSERT	4	
49	507269	PADDLE SHAFT	1	
50	EM200293	PADDLE ARM-TOW END	1	
51	EM200294	PADDLE ARM-CENTER	1	
52	EM200296	PADDLE ARM-ENGINE END	1	
53	EM200295	PADDLE ARM-CENTER	1	
54*#	EM203432	CENTER BACK-UP BLADE	4	
55*#	EM203433	END BACK-UP BLADE	2	
56*	EM200212	TOP RUBBER BLADE (STEEL) DRUM ONLY	4	
56#	EM507519	TOP PLASTIC BLADE (POLY) DRUM ONLY	4	
57*	EM200213	END RUBBER BLADE (STEEL) DRUM ONLY	2	
57#	EM507518	END PLASTIC BLADE (POLY) DRUM ONLY	2	
58	EM963837	BOLT ½-13 X 5-½	1	
59	6109180	LOCK WASHER ½"	1	REPLACES EM923638
60	EM968011	HEX NUT ½"-13	1	
61	507270	SPACER BULL GEAR	1	
	EM200863	BLADE KIT, (STEEL) DRUM ONLY .....	1 .....	INCLS ITEMS w/* AND MTG. HDWR
	EM204625	BLADE KIT, (POLY) DRUM ONLY .....	1 .....	INCLS ITEMS w/# AND MTG. HDWR
	EM203028	HARDWARE KIT, (RUBBER/POLY BLADES) .....	1 .....	INCLUDED IN BLADE KITS

REFER TO PAGES 14 & 15 FOR DRUM HEAD BREAKDOWN

# STEEL DRUM

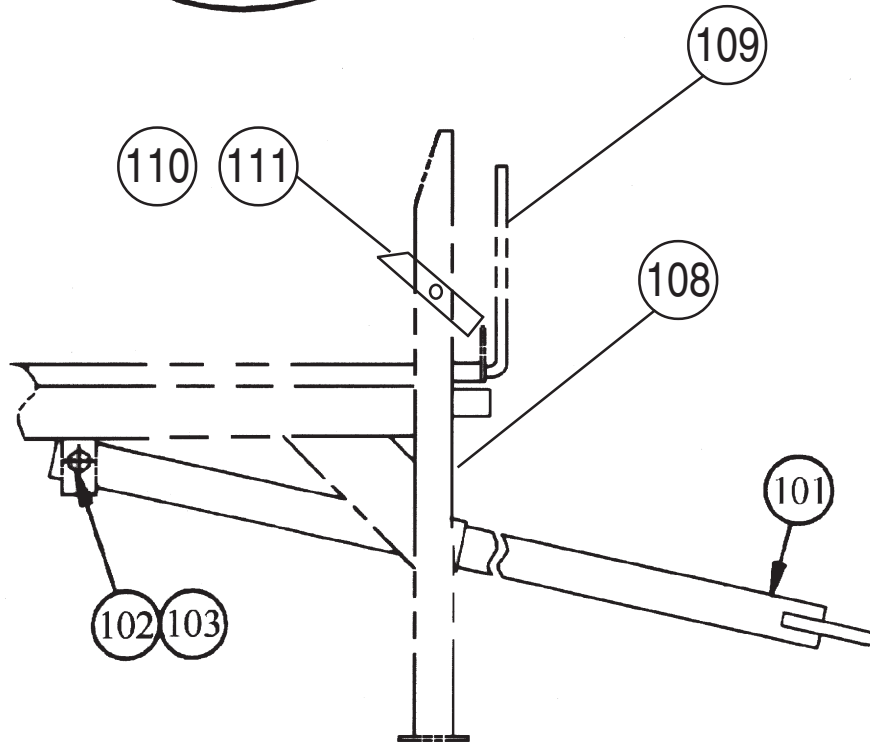
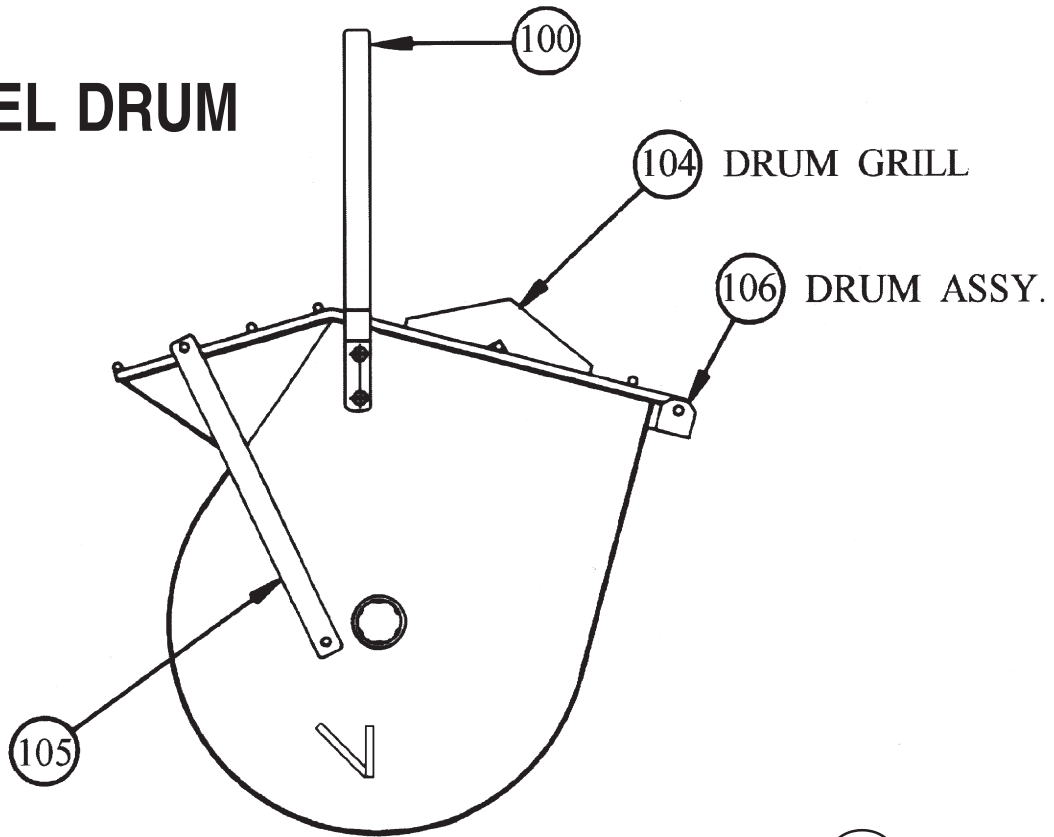

## STEEL DRUM

### COMMON PARTS

<u>NO.</u>	<u>PART NO.</u>	<u>PART NAME</u>	<u>QTY.</u>	<u>REMARKS</u>
100#	EM201537	DUMP HANDLE	1	
101	ELC1	TOWING TONGUE (P. EYE) .....	1	NO LONGER AVAILABLE
101	EPC1	TOWING TONGUE (PIN HOLE) .....	1	CONTACT MQ SALES DEPT./ACCESSORY ITEM
101	EBC1	TOWING TONGUE (BALL HITCH) .....	1	CONTACT MQ SALES DEPT./ACCESSORY ITEM
102	EM963580	CAP SCREW .....	1	REPLACES 505067
103	EM969038	LOCK NUT .....	1	REPLACES 505069
108	EM506309	MAIN FRAME	1	
109	507264	CLUTCH LEVER	1	
110	EM507421	DUMP LATCH	1	
111	EM507835	CLEVIS PIN	1	
104#	EM203332	DRUM GRILL	1	
105#	EM507484	GRILL OPEN BAR	1	
106%	508095	DRUM ASSY (STEEL) .....	1	INCLS. ITEMS w/#
	508096	DRUM & SHAFT ASSY (COMPLETE) (STEEL) .....	1	INCLS. ITEMS w/% AND DRUM HEAD & PADDLE SHAFT ASSY
<input type="checkbox"/>	3148	SAFETY CHAIN .....	1	REPLACES 13363
<input type="checkbox"/>	01004	5/16" CONNECTOR LINK	2	
<input type="checkbox"/>	ILLUSTRATED ON PAGE 9			

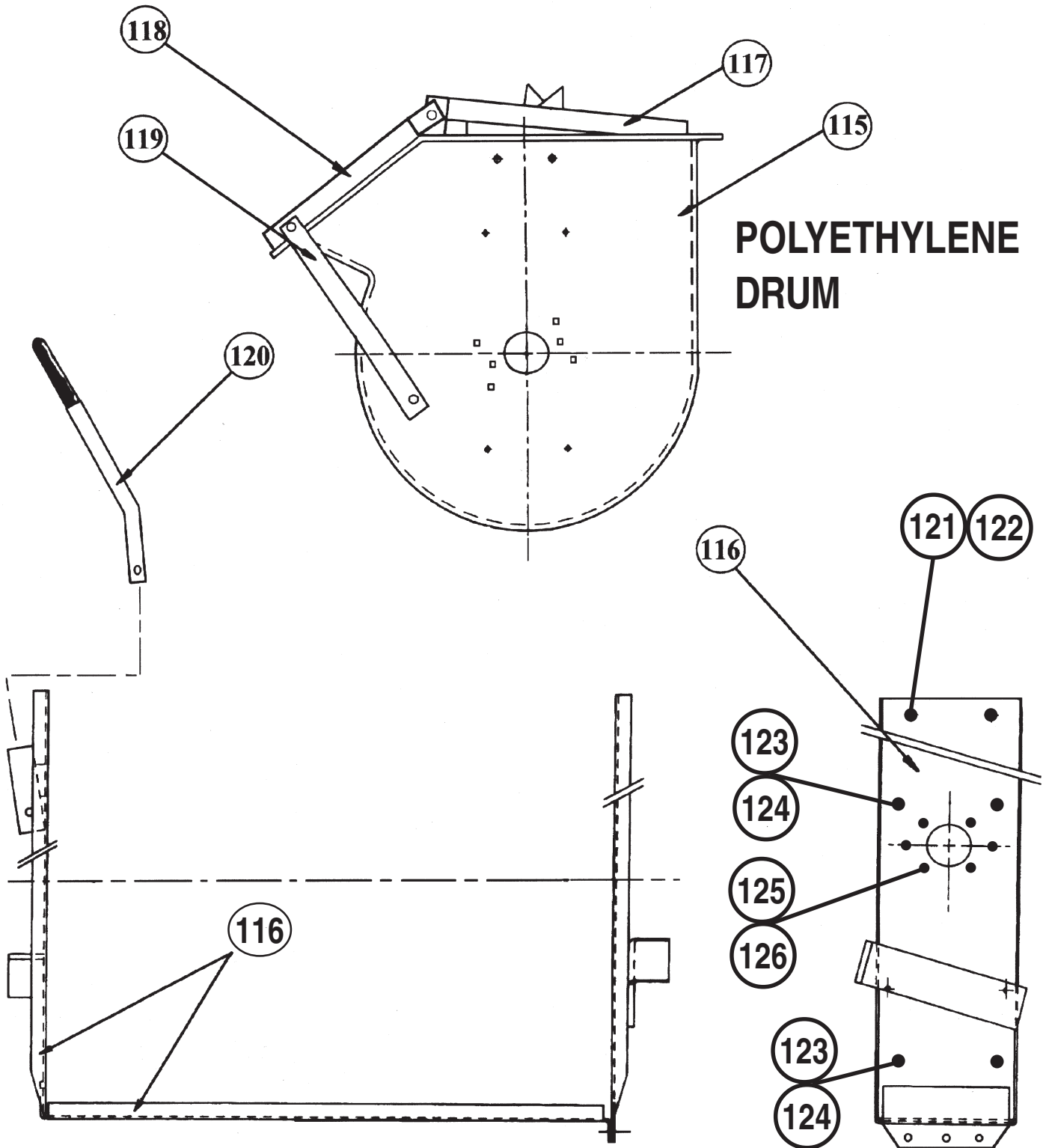

# WM-900P — POLYETHYLENE DRUM

## POLYETHYLENE DRUM

<u>NO.</u>	<u>PART NO.</u>	<u>PART NAME</u>	<u>QTY.</u>	<u>REMARKS</u>
115#	506432	PLASTIC DRUM (W/O GRATES)	1	
116	507549	SUPPORT DRUM	1	
117#	507416	STATIONARY GRATE	1	
118#	507417	MOVEABLE GRATE	1	
119#	507517	GRATE OPEN BAR	1	
120#	509171	DUMP HANDLE	1	
	EM509077	DRUM & SHAFT ASSY (COMPLETE) (POLY) .....	1 .....	INCLS ITEMS w/# AND DRUM HEAD & PADDLE SHAFT ASSY
121	EM963610	HHCS 3/8" NC X 1 1/4" G-5	7	REPLACES 492376
122	EM969013	LOCK NUT 3/8" NC	7	REPLACES 492583
123	5041987	FHCS 1/4" NC X 1" G-5	8	REPLACES 504987
124	EM969079	LOCK NUT 1/4" NC	8	REPLACES 492581
125	504943	FHCS 3/8" NC X 2" G-5	12	
126	EM969013	LOCK NUT 3/8" NC	12	REPLACES 492583

# CAB ASSEMBLY

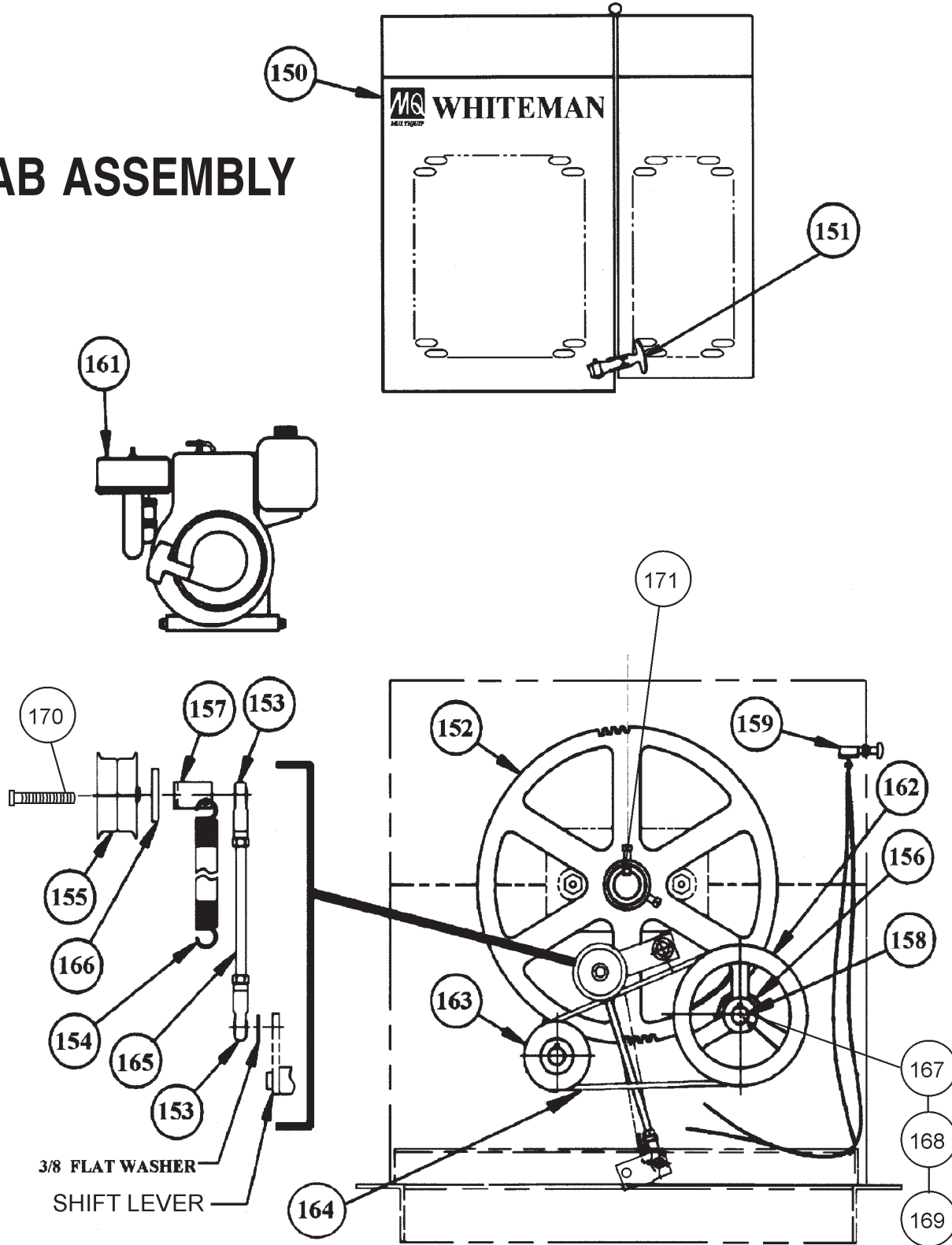

# WM-900S, 900P — GAS ENGINES, PULLEYS & CAB ASSEMBLY

## GAS ENGINES, PULLEYS & CAB ASSEMBLY

### COMMON PARTS

<u>NO.</u>	<u>PART NO.</u>	<u>PART NAME</u>	<u>QTY.</u>	<u>REMARKS</u>
150	507158	CAB ASSEMBLY	1	
151	491010	LATCH ASSEMBLY .....	2	REPLACES 504744
152	502228	DRIVE GEAR 16-½ DIA.	1	
153	EM959080	ROD END	2	
154	EM102014	SPRING	1	
155	EM901515	IDLER PULLEY	1	
156	EM905016	PILLOW BLOCK BEARING	2	
157	EM203098	SPRING CLIP	1	
158	3351	DRIVEN PINION GEAR .....	1	REPLACES 500272
159	EM940734	SWITCH, ON/OFF	1	
167	502226	COUNTER SHAFT	1	
168	JISB2804C25	SNAP RINGS .....	2	REPLACES 490957
169	500214	KEY	1	
170	EM963064	BOLT 3/8 X16 X 3-1/4	1	
171	1141	KEY	1	

### MODEL WM 900 w/HONDA

<u>NO.</u>	<u>PART NO.</u>	<u>PART NAME</u>	<u>QTY.</u>	<u>REMARKS</u>
161	GX240K1HA2	HONDA ENGINE GX240 K1HA 8HP .....	1	REPLACES 493261
161	GX160K1HX2	HONDA ENGINE GX160 5.5HP ENG.	1	
162	492057	DRIVEN PULLEY-LARGE	1	
162	492055	DRIVE PULLEY-5.5 HP	1	
163	EM901074	DRIVE PULLEY-SMALL 1" BORE 8.0 HP	1	
164	EM505834	V-BELT	2	
165	EM507490	THREADED ROD	1	
166	EM507491	IDLER ARM	1	

### MODEL WM 900 w/WISCONSIN

<u>NO.</u>	<u>PART NO.</u>	<u>PART NAME</u>	<u>QTY.</u>	<u>REMARKS</u>
161	EM937171	ENGINE WISCONSIN BKN2-408472 .....	1	REPLACES 505208
162	EM505204	DRIVEN PULLEY	1	
163	505205	DRIVE PULLEY	1	
164	507775	V-BELT	2	
165	EM507771	THREADED ROD	1	
166	EM203352	IDLER ARM	1	

### MODEL WM 900 w/ROBIN

<u>NO.</u>	<u>PART NO.</u>	<u>PART NAME</u>	<u>QTY.</u>	<u>REMARKS</u>
161	W1280800466	ROBIN ENGINE 8HP EY-28 .....	1	UP TO OCTOBER, 1999
161	EH252YR0000	ROBIN ENGINE 8HP EH25-2 .....	1	STARTING OCTOBER, 1999, REPLACES 493260
162	492057	DRIVEN PULLEY-LARGE	1	
163	492054	DRIVE PULLEY-SMALL	1	
164	EM505834	V-BELT	2	
165	EM507490	THREADED ROD	1	
166	EM203352	IDLER ARM	1	

### MODEL WM-900 w/B&S

<u>NO.</u>	<u>PART NO.</u>	<u>PART NAME</u>	<u>QTY.</u>	<u>REMARKS</u>
161	1964521049	B&S ENGINE 8HP .....	1	REPLACES 493181
161	1352321036E1	B&S ENGINE 5HP	1	
162	492057	DRIVEN PULLEY-LARGE	1	
163	EM901074	DRIVE PULLEY-SMALL 1" BORE	1	
164	EM505834	V-BELT	2	
165	EM507490	THREADED ROD	1	
166	EM507491	IDLER ARM	1	

CAB ASSEMBLY

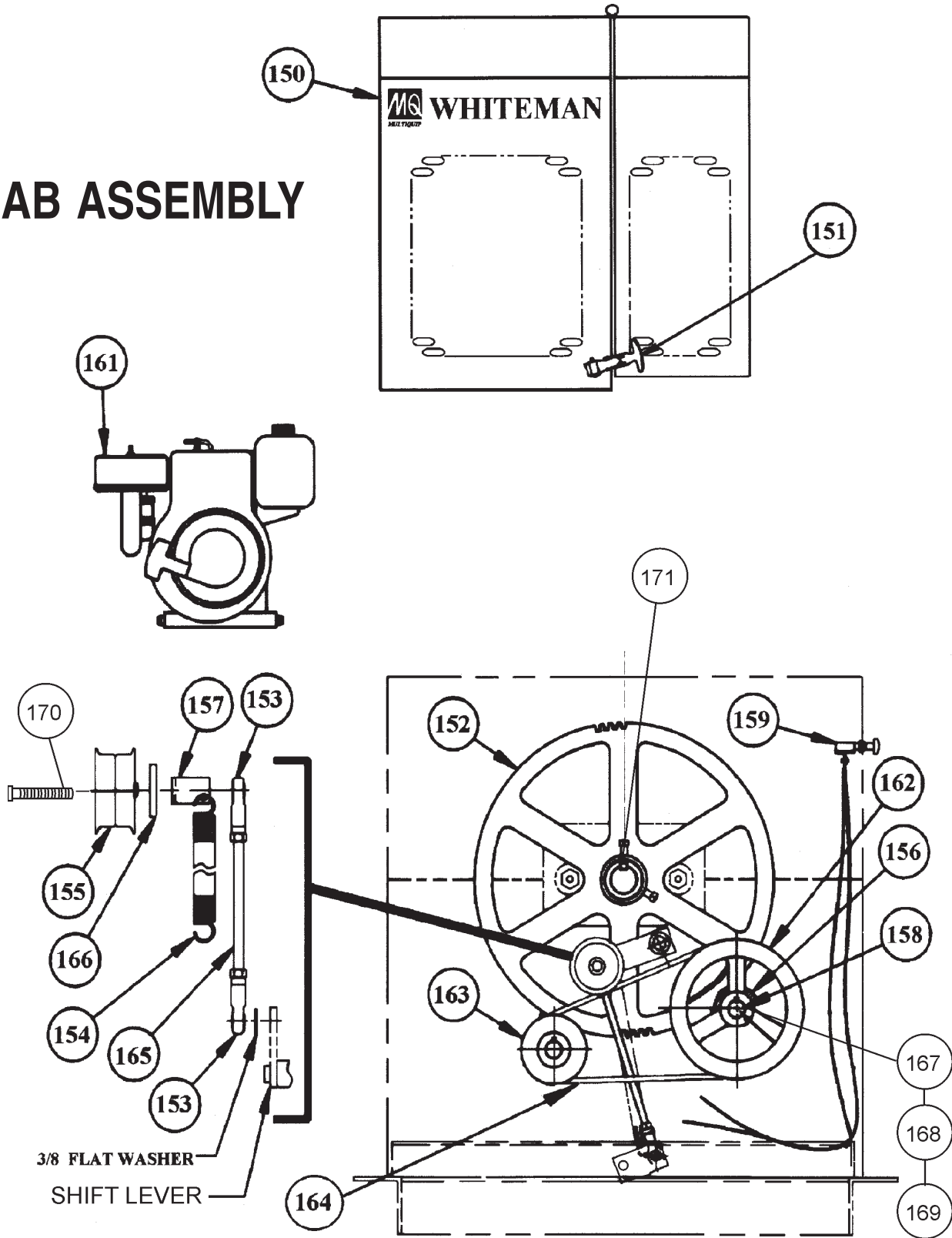



# WM-900S, 900P — ELECTRIC MOTOR & PULLEYS

## CAB ASSEMBLY

<u>NO.</u>	<u>PART NO.</u>	<u>PART NAME</u>	<u>QTY.</u>	<u>REMARKS</u>
161	EM939315	ELECTRIC MOTOR, 3.0 H.P	1	
162	EM505204	DRIVEN PULLEY	1	
163	EM901513	DRIVE PULLEY	1	
164	491115	V-BELT	2	
165	EM507490	THREADED ROD	1	
166	EM507713	IDLER ARM	1	
	507715	GUIDE, V-BELT .....	1 .....	NOT ILLUSTRATED

FOR COMMON PARTS SEE PAGE 23

# WM-900S, 900P — AXLE & WHEEL GROUP

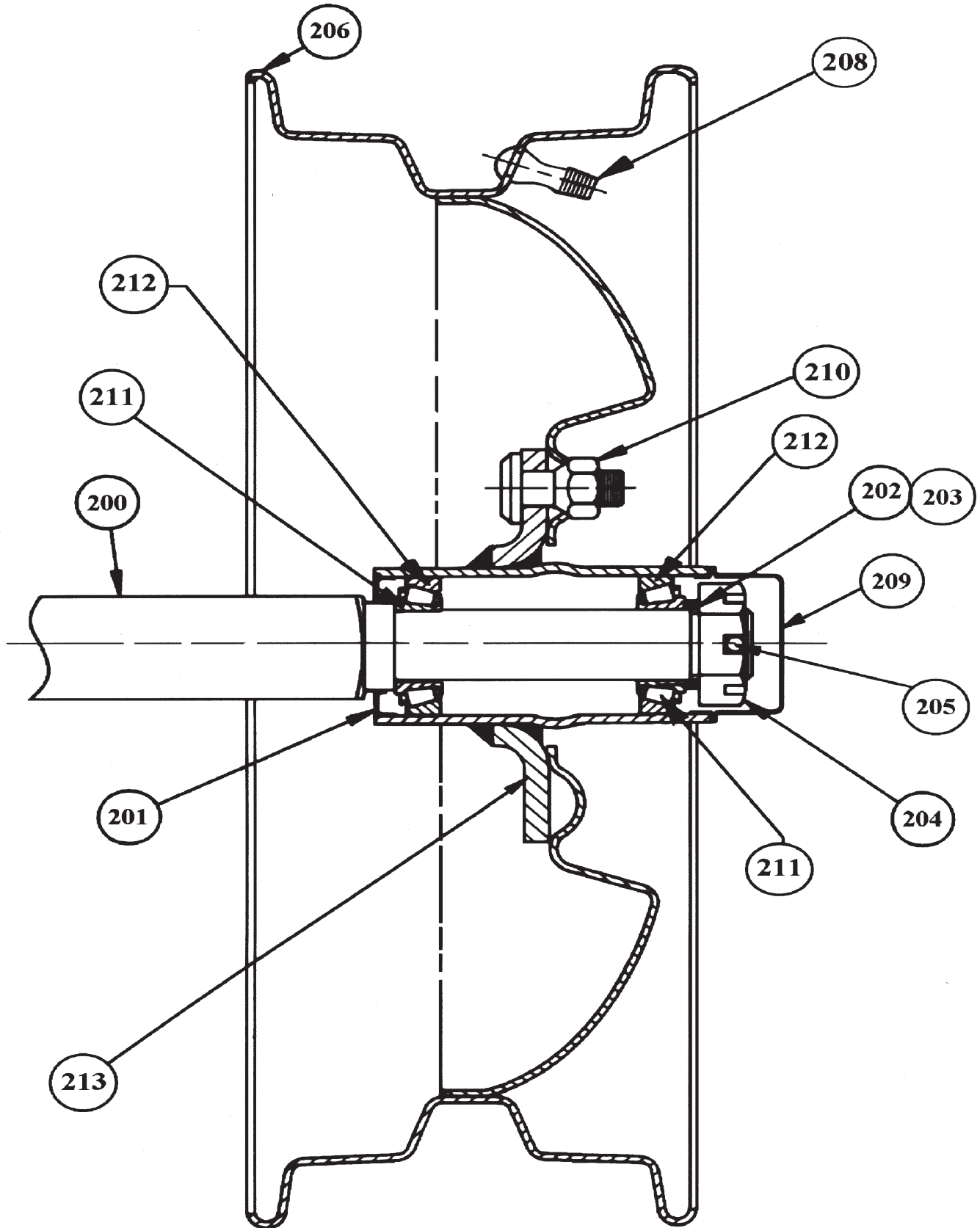

# WM-900S, 900P — AXLE & WHEEL GROUP

## AXLE & WHEEL GROUP

<u>NO.</u>	<u>PART NO.</u>	<u>PART NAME</u>	<u>QTY.</u>	<u>REMARKS</u>
200	EM507407	AXLE .....	1 .....	UP TO S/N HL60000
200	511334	AXLE .....	1 .....	STARTING S/N JA00000
201*#	EM914288	SEAL	2	
202	504708	THICK SPACER .....	2 .....	3/4" INSIDE DIAMETER
203	507444	THIN SPACER .....	2 .....	3/4" INSIDE DIAMETER
204	3068	AXLE NUT .....	2 .....	UP TO S/N HL60000
204	8164	AXLE NUT .....	2 .....	STARTING S/N JA00000
205	0183	COTTER PIN	2	
206	3005	RIM & TIRE ONLY	2	
207	3469	GREASE CAP	1	
208	EM942000	VALVE STEM .....	1 .....	REPLACES 942052
209*#	3469	DUST CAP	2	
210*#	8115	LUG NUT	8	
211*	EM903049	BEARING CONE .....	2 .....	UP TO S/N HL60000
211#	EM903113	BEARING CONE .....	2 .....	STARTING S/N JA00000
212*#	EM903012	BEARING CUP	2	
213	3504	HUB w/CUPS .....	1 .....	UP TO S/N HL60000, INCLS. ITEM w/*
213	EM941306	HUB w/CUPS .....	1 .....	STARTING S/N JA00000, INCLS. ITEM w/#

**PAYMENT TERMS**

Terms of payment for parts are net 30 days.

**FREIGHT POLICY**

All parts orders will be shipped collect or prepaid with the charges added to the invoice. All shipments are F.O.B. point of origin. Multiquip's responsibility ceases when a signed manifest has been obtained from the carrier, and any claim for shortage or damage must be settled between the consignee and the carrier.

**MINIMUM ORDER**

The minimum charge for orders from Multiquip is \$15.00 net. Customers will be asked for instructions regarding handling of orders not meeting this requirement.

**RETURNED GOODS POLICY**

Return shipments will be accepted and credit will be allowed, subject to the following provisions:

1. A Returned Material Authorization must be approved by Multiquip prior to shipment.
2. To obtain a Return Material Authorization, a list must be provided to Multiquip Parts Sales that defines item numbers, quantities, and descriptions of the items to be returned.
  - a. The parts numbers and descriptions must match the current parts price list.
  - b. The list must be typed or computer generated.
  - c. The list must state the reason(s) for the return.
  - d. The list must reference the sales order(s) or invoice(s) under which the items were originally purchased.
  - e. The list must include the name and phone number of the person requesting the RMA.
3. A copy of the Return Material Authorization must accompany the return shipment.
4. Freight is at the sender's expense. All parts must be returned freight prepaid to Multiquip's designated receiving point.
5. Parts must be in new and resalable condition, in the original Multiquip package (if any), and with Multiquip part numbers clearly marked.
6. The following items are not returnable:
  - a. Obsolete parts. (If an item is listed in the parts price book as being replaced by another item, it is obsolete.)
  - b. Any parts with a limited shelf life (such as gaskets, seals, "O" rings, and other rubber parts) that were purchased more than six months prior to the return date.
  - c. Any line item with an extended dealer net price of less than \$5.00.
  - d. Special order items.
  - e. Electrical components.
  - f. Paint, chemicals, and lubricants.
  - g. Decals and paper products.
  - h. Items purchased in kits.
7. The sender will be notified of any material received that is not acceptable.
8. Such material will be held for 5 working days from notification, pending instructions. If a reply is not received within 5 days, the material will be returned to the sender at his expense.
9. Credit on returned parts will be issued at dealer net price at time of the original purchase, less a 15% restocking charge.
10. In cases where an item is accepted for which the original purchase document can not be determined, the price will be based on the list price that was effective twelve months prior to the RMA date.
11. Credit issued will be applied to future purchases only.

**PRICING AND REBATES**

Prices are subject to change without prior notice. Price changes are effective on a specific date and all orders received on or after that date will be billed at the revised price. Rebates for price declines and added charges for price increases will not be made for stock on hand at the time of any price change.

Multiquip reserves the right to quote and sell direct to Government agencies, and to Original Equipment Manufacturer accounts who use our products as integral parts of their own products.

**SPECIAL EXPEDITING SERVICE**

A \$20.00 to \$50.00 surcharge will be added to the invoice for special handling including bus shipments, insured parcel post or in cases where Multiquip must personally deliver the parts to the carrier.

**LIMITATIONS OF SELLER'S LIABILITY**

Multiquip shall not be liable here under for damages in excess of the purchase price of the item with respect to which damages are claimed, and in no event shall Multiquip be liable for loss of profit or good will or for any other special, consequential or incidental damages.

**LIMITATION OF WARRANTIES**

No warranties, express or implied, are made in connection with the sale of parts or trade accessories nor as to any engine not manufactured by Multiquip. Such warranties made in connection with the sale of new, complete units are made exclusively by a statement of warranty packaged with such units, and Multiquip neither assumes nor authorizes any person to assume for it any other obligation or liability whatever in connection with the sale of its products. A part from such written statement of warranty, there are no warranties, express, implied or statutory, which extend beyond the description of the products on the face hereof.



# PARTS AND OPERATION MANUAL

## **HERE'S HOW TO GET HELP**

*PLEASE HAVE THE MODEL AND SERIAL NUMBER  
ON-HAND WHEN CALLING*

### **PARTS DEPARTMENT**

*800-427-1244 or 310-537-3700*

*FAX: 800-672-7877 or 310-637-3284*

### **SERVICE DEPARTMENT/TECHNICAL ASSISTANCE**

*800-478-1244 or 310-537-3700*

*FAX: 310- 537-4259*

### **WARRANTY DEPARTMENT**

*888-661-4279, or 310-661-4279*

*FAX: 310- 537-1173*

### **MAIN**

*800-421-1244 or 310-537-3700*

*FAX: 310-537-3927*



**MULTIQUIP INC.**

POST OFFICE BOX 6254

CARSON, CA 90749

310-537-3700 • 800-421-1244

FAX: 310-537-3927

E-MAIL: [mq@multiquip.com](mailto:mq@multiquip.com)

WWW: [multiquip.com](http://multiquip.com)

Atlanta • Boise • Dallas • Houston • Newark  
Quebec, Canada • Manchester, UK • Rio De Janeiro, BR • Guadalajara, MX