

Owner's Manual

Model

260

RECORDER/MIXER



Fostex[®]

Figure Model 260 Main Panel Features

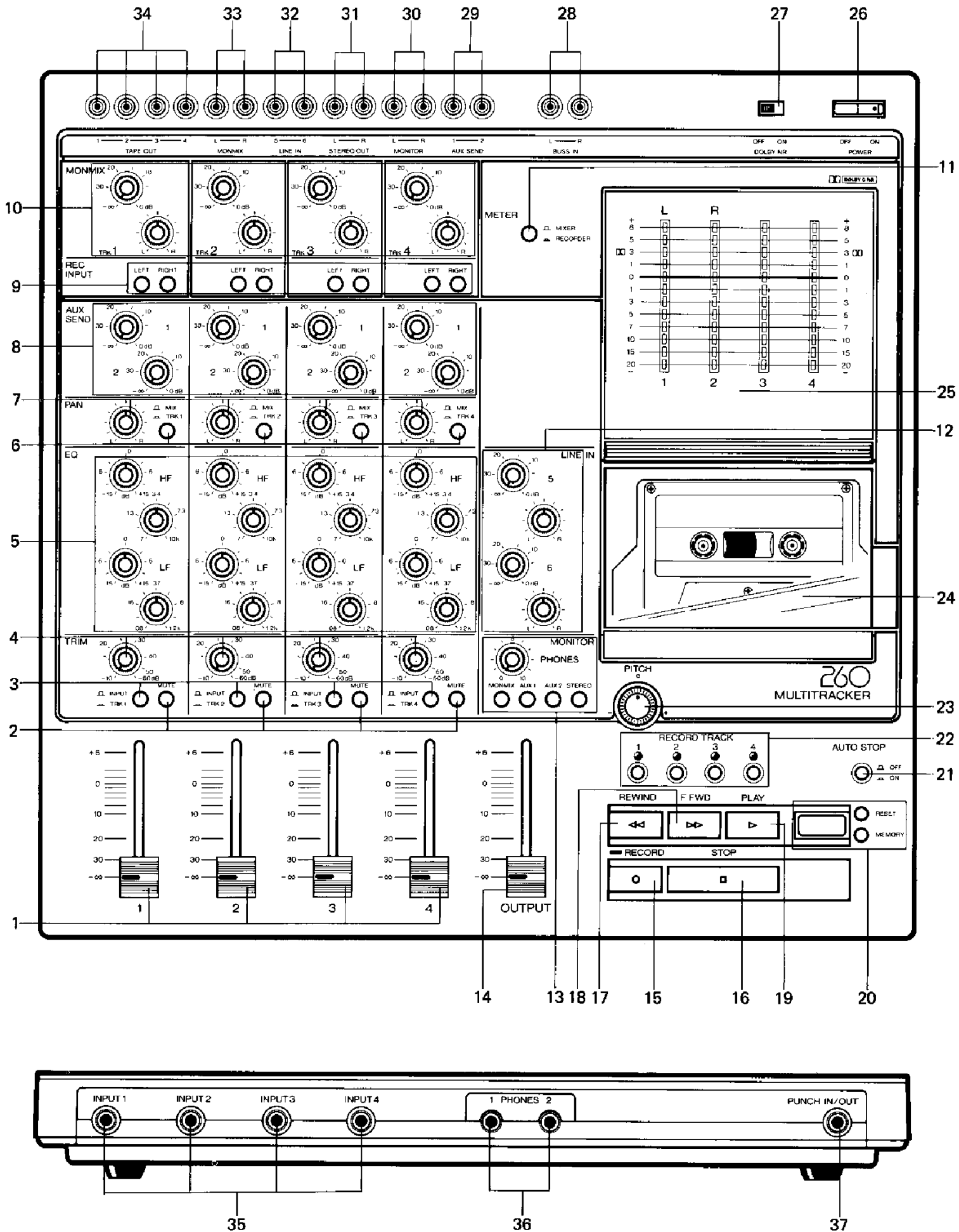

SECTION 1. CONTROLS, INDICATORS AND CONNECTORS

MAIN PANEL FEATURES

Input Channels 1 — 4

1. INPUT FADER

This fader controls the signal level from either of two sources: that channel's input jack or playback from the cassette recorder—depending on the position of the INPUT BUTTON (3). To ensure low distortion and to achieve the best signal-to-noise ratio, set this fader in the range of 0dB \pm 2 scales (nominal position). When the INPUT BUTTON is up, the TRIM control also affects signal level for that channel.

2. MUTE BUTTON

This push-to-engage button temporarily cuts off the signal on that channel, whether input or tape. If you wish to solo one channel, simply mute the others.

3. INPUT BUTTON

In the up or INPUT position, this channel receives signal from the corresponding input jack; in the down or TRK position, this channel receives the playback signal from the corresponding track on the cassette tape.

4. TRIM CONTROL

This control continuously adjusts the internal preamplifier gain over a 50 dB range. In the full CCW position (–10), the channel input is suitable for use with most line level signals, such as those from tape recorders and most electronic musical instruments (nominal –10 dBV, 0.3V rms). As you rotate the control to the full CW position, gain increases 50 dB to accommodate the typical output of a dynamic microphone (nominal –60 dB, 1 μ V rms). Intermediate settings are suitable for use with condenser microphones, hot guitar pickups and so forth. The best setting for any input signal level is determined by the interaction of the FADER (1) with its corresponding TRIM control. Note that this control has no effect on signals from the cassette tape; the playback level is preset for your convenience.

5. PARAMETRIC EQUALIZER

These sophisticated tone controls give you maximum control over your sound. The low frequency band (LF) is continuously variable from 80 Hz to 1.2 kHz, \pm 15 dB; the high frequency band (HF) is continuously variable from 700 Hz to 10 kHz, \pm 15 dB.

- If you know what frequency range is in need of adjustment, first use the sweep control to set the hinge point, then set the gain control for the amount of boost or cut desired.
- If you are making EQ adjustments by ear, first turn the gain control to maximum boost or cut; use the sweep control to identify the frequency range, then back off to amount of boost or cut desired.
- If both sweep controls are set to overlap — the high end of the low frequency band with the low end of the high frequency band — be judicious in the use of the level controls. As the sweep controls approach the same frequency, 30 dB of boost or cut is available. That's a whole lot more than you'll probably ever need!

6. STEREO MASTER SELECT BUTTON

In the up or MIX position, the signal from this channel will be fed to the Stereo Master Buss. Stereo imaging is dependent upon the setting of the REC INPUT Selectors (9) and the PAN CONTROL (7).

In the down or TRK position, the signal from this channel will be fed directly to the corresponding track, by-passing the Stereo Master Buss and, of course, the PAN CONTROL (7).

NOTE: If you want to record "direct," by-passing the Stereo Master Buss, be sure the REC INPUT selectors are up.

7. STEREO MASTER PAN CONTROL

When the STEREO MASTER SELECT Button (6) is in the up or MIX position, the Pan Control will place the signal from this channel anywhere within the stereo panorama.

8. AUX SEND

The two AUX SEND controls for each input channel are post fader and post equalizer. These independent mono send circuits are designed to feed external signal processing equipment from AUX SEND Jacks 1 & 2 (29). Effects returns are then received (32) and controlled by Pan and Gain (12). The MONMIX controls (10) and their output jacks (33) may be used as a stereo send, if necessary.

9. REC INPUT

These two select buttons control the routing of signals to the Stereo Master Buss, either Left or Right. When both are depressed, the PAN CONTROL (7) will be by-passed, and the record signal will be summed to Stereo Master Buss. This particular record select arrangement is very convenient for bouncing tracks. See Section 6 for instructions on ping-ponging.

NOTE: These input selectors are for the Stereo Master Buss only. When you want to record "direct" turn these selectors off (up) and press that track's Pan Select (Mix/Trk) (6) button.

10. MONMIX

These Pan and Gain controls give you a separate, independent stereo mix of the cassette recorder. Normally, they will be used to supply a cue feed for the musicians, but they can also be used readily for a stereo effects send.

11. METER SELECT

This button determines the signals displayed on the four LED Bar Graph Meters (25). In the up or MIXER position, the meters will display signal levels for the Stereo Buss (L and R). When the Stereo Master Buss is engaged, meters 1 and 2 will function, respectively, as Left and Right. In the down or RECORDER position, the meters will indicate input level status for those tracks in the record mode, and output level status for those tracks in the playback mode.

12. LINE IN 5 & 6

These line level signals can each be independently adjusted for gain and pan, and then fed to the Stereo Master Buss. As such, they are ideal for effects returns. Synth players will especially appreciate two extra line inputs.

13. MONITOR/PHONES

You can selectively monitor any of four different signal groups, just with the press of a button: MONMIX (33), AUX SEND 1 (29), AUX SEND 2 (29), or the STEREO MASTER Buss Out (31). The MONITOR OUT jacks (30) and the HEADPHONE jacks (36) are wired in parallel; the Headphone signal has a separate, independent level control.

- As a special feature, your 260 is tailor-made for a "rolling punch." Select both MONMIX and STEREO in the (Cue) MONITOR/PHONES circuit. You will hear the recorded track and the input signal as you rehearse before the punch-in point. When you then enter RECORD, the monitor switches automatically to input.

14. STEREO MASTER

Overall output level control for the Stereo Master Buss.

TAPE TRANSPORT FEATURES

15. RECORD BUTTON AND LED INDICATOR

The effect of pressing the record button will vary, depending upon the status of other controls. There are three main operations:

- (a) LEVEL SET. With the recorder in the STOP mode, press the RECORD button alone and its LED will blink in green. Engage the RECORD TRACK SELECTORS (22) for the track(s) you wish to record, and use the Fader (14) and Trim (4) controls to set proper levels before you begin recording.
- (b) NORMAL RECORDING. After setting proper levels as indicated above, simply press RECORD and PLAY simultaneously. All blinking LEDs (indicating Record READY status) now remain lighting (indicating Recording in Progress.) and the RECORD LED will be lit in red.
- (c) PUNCH-IN RECORDING. There are two ways to accomplish Punch-in recording manually. First, depress the RECORD TRACK SELECTOR button(s) for the channel(s) you wish to record on, press PLAY and when you reach the punch-in point, press PLAY and RECORD simultaneously. The second way to manually punch-in is to release all RECORD TRACK SELECTOR buttons (22) and press RECORD and PLAY simultaneously. The RECORD LED will be lit in green, indicating Record READY, as the transport enters PLAY. At the Punch-in spot, press the appropriate RECORD TRACK SELECTOR button(s) and the monitor function instantly changes to input as you enter the RECORD mode. All LEDs remain on.

You can also Punch-in with the optional Remote Foot Control, Model 8051. Simply depress the appropriate RECORD TRACK SELECT button(s), place the transport in PLAY, and use the Remote Foot Control Switch to Punch-in and -Out.

16. STOP BUTTON

Cancels any previously selected transport command and stops tape travel.

17. REWIND BUTTON <<

Cancels any previously selected transport command and tape begins spooling to the supply reel (from right to left) at high speed.

18. FAST FORWARD BUTTON >>

Cancels any previously selected transport command and tape begins spooling to the take-up reel (from left to right) at high speed.

19. PLAY BUTTON >

Advances tape to the take-up reel (from left to right) at a constant speed of 3-3/4 ips (9.5 cm/sec), plus or minus any effect of the PITCH CONTROL (23), if engaged.

20. TAPE INDEX COUNTER WITH MEMORY AND RESET

The 4-digit LCD indicates relative tape position. Pressing the adjacent RESET button sets the display at 0000. Pressing the adjacent MEMORY button, programs the AUTO STOP (21) function.

21. AUTO STOP

The transport may be programmed to search and automatically stop at two different points: one is set by the MEMORY button (20) and the other is the 0000 reference set by the RESET button (20).

22. RECORD TRACK SELECTORS

One button per track with a corresponding LED which indicates -

- (a) RECORD SAFE status (recording will not take place), when unlit,
- (b) RECORD READY status (recording will take place when the proper command is given), when blinking, and
- (c) Recording in Progress, when lighted.

23. PITCH CONTROL

This control can vary tape speed $\pm 15\%$. CCW rotation decreases tape speed; CW rotation increases tape speed. There is a click-stop OFF position in the center. You can use this control to compensate for tuning irregularities as well as for creative effects.

24. CASSETTE WELL AND COVER

A transparent, curved plastic cover protects the cassette during operation. To insert or remove a cassette, lift the cover manually.

NOTE: Use ONLY C-60S or C-90S, High Bias 70 μ sec EQ — TDK-SA, Maxell UD-HL II, or equivalent.

25. METER PANEL

Four highly accurate LED Bar Graph meters are housed in smoked plexiglass for easy viewing. They can be switched to read the mixer or the recorder, stereo (1 & 2 = L & R) or 4-track (1,2,3,4).

CONNECTIONS AND SWITCHES

26. POWER

On-Off Switch.

27. DOLBY C NR

On-Off Switch.

28. BUSS IN L & R

Left and Right inputs to the Stereo Master Buss just before the Stereo Master Output Fader (14).

29. AUX SEND

Two pin jacks for mono outputs.

30. MONITOR

Left and Right pin jacks for stereo output to main monitors.

31. STEREO MASTER OUT

Left and Right pin jacks for the output of the Stereo Master Buss.

32. LINE IN 5 & 6

Two additional line level inputs, each adjustable for Pan and Gain, are then assigned to the Stereo Master Buss.

33. MONMIX

Left and Right pin jacks for the output of the recorder — track status is dependent upon other controls. Easily used as a stereo send, these outputs will typically feed the Cue amplifier.

34. TAPE OUT

These four pin jacks carry the track outputs from the recorder directly. If signal is present on the tape, it appears at these outputs, regardless of input Select status.

FRONT PANEL FEATURES

35. INPUT JACKS

Four 1/4" phone jacks for mic or line level sources. Use these inputs as the reference for channel assignment.

36. HEADPHONE JACKS

Two standard Headphone jacks are wired in parallel.

37. PUNCH IN/OUT

1/4" Phone jack for connecting Model 8051, Optional Remote Control Foot Switch.

SECTION 2. INTRODUCTION.

Your FOSTEX 260 incorporates a 6-input x 4-output mixer with an independent stereo buss and a 4-track, 4-channel cassette tape recorder.

With the very portable Model 260, setting up an "Instant" recording studio is as easy in a hotel room or at a friend's place as it is at home. The system is ideal for making original multi-track recordings, overdubbing, and mixing down to stereo. The Model 260 provides many alternate signal flow paths, thanks to a variety of assignment switches, pan pots and auxiliary in/out jacks. This not only provides creative flexibility, it also enables the unit to serve as a back-up mixer for simple sound reinforcement applications.

Live instruments and vocals tend to generate high instantaneous peak levels, and sometimes low average levels, both of which tax the limits of the mixing and recording equipment. These extremes—the difference between maximum undistorted recording level and the noise floor—constitute the *dynamic range* of the program. In commercial recordings and broadcasts, such extremes in dynamics have already been compressed by a variety of signal processing. This is why consumer tape recorders can yield acceptable results even though they offer limited dynamic range. When making live recordings, however, the ability to handle wide dynamics is far more critical. For this reason, Fostex engineers have given special attention to maximizing the dynamic range of the cassette recorder and of the mixing electronics.

The result is excellent audio performance, with wide bandwidth (wide frequency response), low distortion and low noise. To improve tape record/play performance, a new track/speed format has been adopted. Standard cassettes are utilized, but the tape head configuration and running speed are modified for optimum four-channel operation.

SECTION 3. INITIAL RECORDING (MAKING THE BASIC TRACKS)

For purpose of explanation, let's assume a single musician working alone with a drum machine, synths, guitars and keyboards. Plus a pretty good idea of how things are going to come together.

1. Start by "zeroing" all controls. Set all faders, knobs and controls to their off or neutral positions. Each adjustment you make from this point on should be purposefull.
2. Suppose the drum machine has a stereo output. Connect those leads (L & R) to input jacks 3 & 4 (35) respectively on your 260.

NOTE: You could, of course, choose tracks 1 & 2 just as easily. Our choice here will become apparent as you read on.

3. Make sure the Input Select Buttons (3) and Pan Select Button (6) are up (INPUT and MIX, respectively).
4. Select Rec Input (9) Left for Track 3, Right for Track 4.
5. Set the Meter Select Button (11) to the Up/MIXER position. The L & R metering positions are fixed for channels 1 & 2. In this case, L is assigned to track 3, R to track 4.
6. Select Stereo for the MONITOR/PHONES Assignment (13).
7. Select Tracks 3 & 4 of the Record Track Selectors (22).
8. Press the RECORD Button (15) once.
9. Advance the OUTPUT Fader (14) to the 0 position. Now start the drum machine.
10. Slowly advance Input Faders 3 & 4 (1) and adjust the Headphone Level Control (13). Just set a relative level reference at this point.

11. Books have been written about equalization. Now it's your turn. You get to decide how much is enough.
12. Now use the Trim controls (4), if necessary, so that the loudest parts register in the +3 to +5 range. At this point, everything should be under control from the output stage of the drum machine to the input stage of the recorder. The best advice we can give you here, especially if you're about to make your first recording with the 260, is to make a trial recording. Thirty seconds or so is all you need. Rewind, and play it back through MONMIX (10). If it sounds very close to the recording, and the meters read about the same, you're ready to go on. If you find a big difference between record levels and playback levels, adjust the input level controls (1), Trim controls (4) and adjust your amplifier or headphone level control (13) which, of course, have no effect on the record level.
13. Cue the drum machine.
14. Check to be sure you're not trying to record on the leader portion of the tape, set the LCD counter (20) to 0000, press REC (15) and PLAY (19) simultaneously, then start the drum machine.
15. Adjust relative levels (L and R) with the input Faders (1) and overall level with the Master Output Fader (14).
16. When the recording is completed, press STOP.

PLAYING BACK BASIC TRACKS

Before you do anything, disengage the RECORD TRACK Selectors (22).

1. Press REWIND \ll (17) and cue the tape to the beginning.

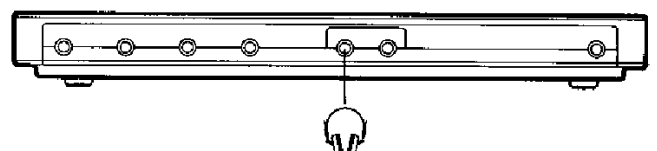
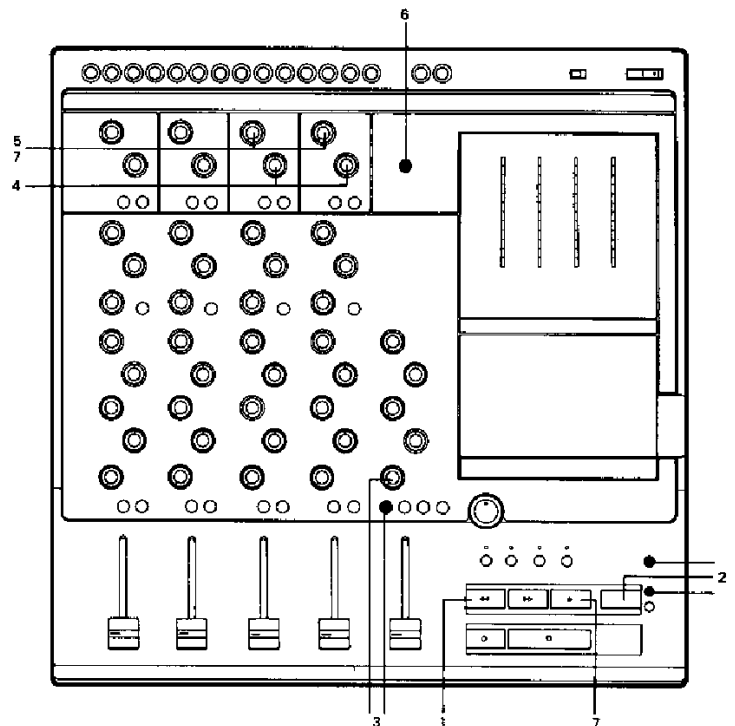
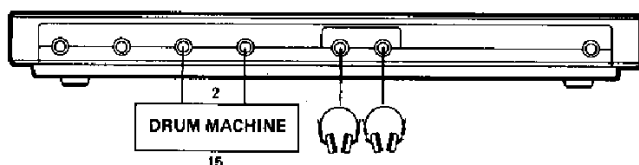
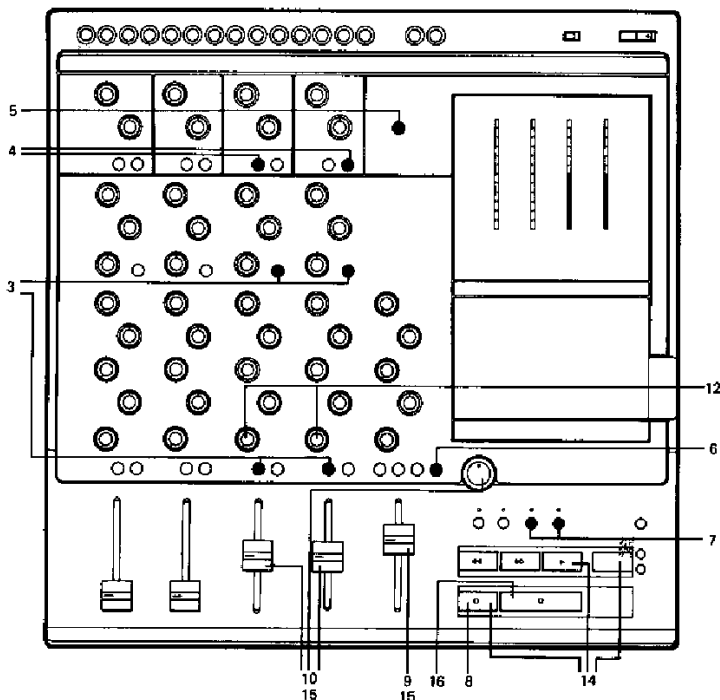

2. Now press AUTO STOP (21) On (down), and RESET (20) the LCD counter (20) to 0000. The tape will now automatically stop at this position from the REWIND mode, until the AUTO STOP function is disengaged.
3. Typically, at this point, you would have to make notes about where the faders, EQ and Pan controls were set for the recording, identify the take, then zero all the controls and re-set them for Playback. But your 260 has a better design. Leave everything as it was, and press MONMIX in the MONITOR Select (13).
4. Turn MONMIX Pan (10) full Left on Track 3, full Right on Track 4.
5. Adjust MONMIX Gain (10) to approximately -10 (2 O'Clock position) for Tracks 3 & 4.
6. Set Meter Select (11) to the RECORDER (down) position.
7. Press PLAY > (19) and you will be able to evaluate the

recording. Adjust MONMIX Gain (10) as necessary, in addition to headphone and/or amplifier gain.

NOTE: You may find yourself making this basic recording over and over again. Until it's just right. You may also find that one take is almost perfect, except for one mistake. Instead of recording the whole track over again, you may wish to fix the mistake by punching-in and out (see Section 8).

SUGGESTION: Sometimes the multitrack recording process can get out of hand when you try to keep everything inside your head. Note pads and track sheets (see sample on Page 16) make this process a whole lot easier.

SECTION 4. OVERDUBBING

Overdubbing, or Sync Recording, is the primary benefit of multitrack recording. You may have an occasional need to record all 4 tracks simultaneously, but the standard multitrack procedure is to record one or two tracks at a time. This way, you can concentrate on each component part, literally building a song.

1. Zero all controls.
2. To continue with our example (stereo drums on 3 & 4), now let's overdub the bass guitar. Instead of using a mic on the bass amp, let's plug the bass directly into Channel 2 (35).
3. MONMIX will be the standard Monitor Select (13) position for overdubbing. You will always be able to set up an independent stereo mix from the recorder on the MONMIX buss. Whatever the source/tape status, each track will appear on the MONMIX buss. Switching is automatic.

Caution: There is one special ping-pong application where the settings for the 260 permit mixing of tape signals with input signals. When a REC INPUT (9) button is down, in addition to that track's "direct" button (6), Pan Control (7) settings for the other channels may assign signals to the stereo buss for recording. In almost all overdub applications you do not want the tape signal mixed with the input signal, except, of course, in the headphones. Hence the importance of always zeroing the controls before the start of any major operation.

4. Set the Meter Select Button (11) to the RECORDER (down) position.
5. Select INPUT (3) for Channel 2 and set the input level with the Fader (1) and TRIM (4) Controls. Note that the Master Fader (14) is not in the circuit at this point.
6. Press the Pan Select Button (TRK 2).
7. Press the Record Track Selector (22) for Track 2.
8. Now press PLAY > and rehearse. First set the MONMIX controls (10) so that you have a comfortable mix of the track (3 & 4) and the live part (Bass on 2) in the

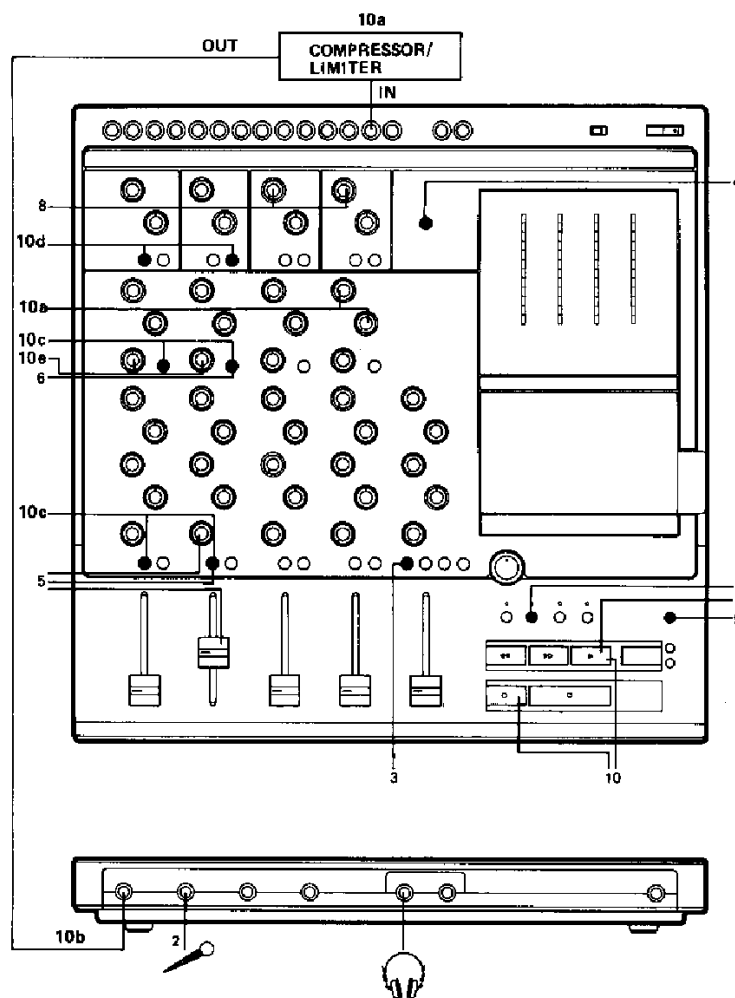

headphones. Then set the input level controls for the proper record level.

9. You'll probably want to rehearse the first overdub several times. Now you'll really appreciate the return-to-zero and AUTO STOP (21) function of the 260.

10. When you're ready to make the overdub, cue the tape and press **PLAY >** and **RECORD** simultaneously. After a few attempts, suppose you decide to add a compressor. Here's how to patch one in:
 - a. Connect a lead from **AUX SEND 1 (29)** to the Line input on the Compressor (you may need a pin jack to phone jack adaptor), and adjust Gain with the **AUX SEND Level Control (8)**.
 - b. Connect a lead from **Line Out** on the Compressor to the **Channel 1 input (35)**.
 - c. Place both **Input Selectors (3)** to **INPUT** and both **Pan Selectors (6)** to **MIX** for Channels 1 & 2.
 - d. Select **Left REC INPUT (9)** for Track 1, **Right** for Track 2.
 - e. Now turn both **Pan Controls (7)** fully **CCW (left)**.
 - f. Channels 1 & 2 of the mixer are now feeding Track 2 of the recorder with an incredible amount of tone and gain control, both to (**Channel 2**) and from (**Channel 1**) the Compressor.

When you have three tracks recorded, it's time for decisions. How many more parts to record? What are the best sub-groups for combining tracks? You may want to turn to **Ping-pong Recording, Section 6**, to see what your options are.

The Final Overdub

Scheduling the sequence of the tracks to be recorded is often the key to a successful recording. There are no hard rules, only guidelines. A rhythm part is generally the first to be recorded because it serves as a common reference for all other parts. Background vocals/fills are usually next because they can be combined and bounced, thereby leaving room for still more parts. Leads and solos are typically the last parts to be recorded, so that they are first generation recordings on the multitrack master tape.

SECTION 5. MIXDOWN

When the multitrack master tape has been completed, give your ears a rest before going on to the next step in the process, the mixdown. Some producers believe that mixing is a craft, others maintain that it's an art. Nobody thinks it's easy. Mixing requires intense concentration and the patience to listen over and over until all the elements are blended the best they can be.

The following example is a typical mixdown set-up with the 260.

1. Zero all controls and connect the **MONITOR (30)** outputs to an amp which drives two speakers. You're going to be making value judgments about improving what you hear, so use the best speakers you can buy, borrow or beg.
2. Connect the **STEREO OUT (31)** leads to your mixdown recorder, and connect the outputs of that machine to the **Line inputs (32)** of Channels 3 & 4.
3. Release all **RECORD TRACK (22)** Selectors and **REC INPUT (9)** Buttons.
4. Select the **TRK** position (down) on all four **INPUT (3)** Selectors.
5. Select the **MIX** position (up) on all four **Pan (6)** Selectors.
6. Select the **MIXER** position (up) on the **Meter Select (11)** Button.
7. Interconnect any signal processors (such as a reverb) using the **AUX SEND Controls (8)** and jacks (29); connect the return leads to **LINE IN 5 & 6 (32)** for Pan and Gain control before routing to the **Stereo Master Buss**. A separate stereo mix may be obtained from the **MONMIX** outputs (33), which may then be processed and returned to the stereo buss via the **Buss inputs (28)**.
8. Press **PLAY > (19)** and set a relative balance among the four tracks with the **input faders (1)**; set the overall output level with the **Master Fader (14)**.
9. Adjust the monitor levels as necessary and adjust the input level controls of the mixdown recorder.
10. Cue the tape and record a minute or so of a trial mix for the purpose of checking the system level balance.

11. Rewind the mixdown tape and play it. Set the **INPUT Select (3)** on 3 & 4 to **Input**, and listen carefully to make sure there is a relative balance between the output level of the 260 and the input/output levels of the mixdown recorder.
12. Reset the **INPUT Select (3)** buttons on 3 & 4 to **TRK** (down), cue both tapes and record your mixes. Now is the time, incidentally, for some open-minded experimentation. You might just come up with a great idea during mixdown that sends you back to re-record a part, thereby making the song stronger.

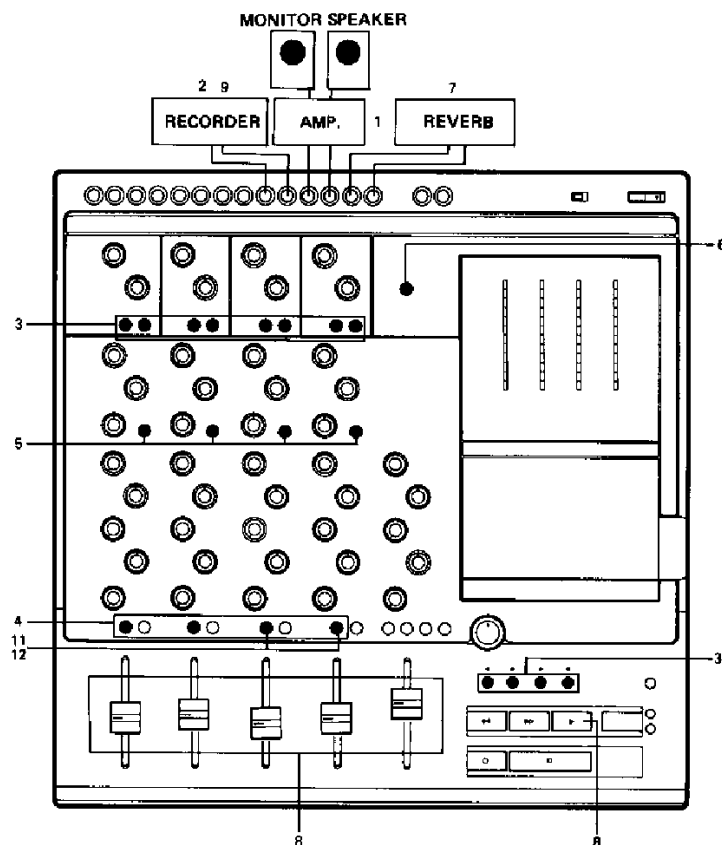

SECTION 6 PING-PONG RECORDING — BOUNCING TRACKS.

Your 260 is especially well-designed for ping-pong recording. Build a composition track by track, combining some tracks in order to make room for others.

The key idea in this operation is to use the independent stereo buss with its REC INPUT selectors (9), Left and Right. For convenience, save Tracks 1 & 2 for the stereo master buss, because meters 1 & 2 can be switched to read L & R.

The REC INPUT Selectors (9) will override the "direct" to TRK recording button (6) so that whenever the Stereo Master Buss has been selected, it controls the final routing of input and tape signals.

Example 1: Single musician with multiple instruments.

1. Record drum machine on track 4.
2. Record bass guitar on track 3.
3. Record rhythm keyboard on track 2.
4. Bounce Tracks 4, 3 & 2 to Track 1, while simultaneously playing acoustic rhythm guitar.
 - a. Input Select (3) to TRK on 2 — 4; INPUT on 1.
 - b. Adjust EQ (5) on 2 — 4; Trim (4) and EQ on 1.
 - c. All 4 Pan Select buttons (6) to MIX (Up).
 - d. All 4 REC INPUT Select (9) to LEFT. (Note that this assignment by-passes the Pan Control for the Stereo Master Buss.)
 - e. REC TRK Select (22) 1.
 - f. Meter Select (11) to RECORDER (down).
 - g. Practice the record/playback levels until you're ready to make the recording, then do it.

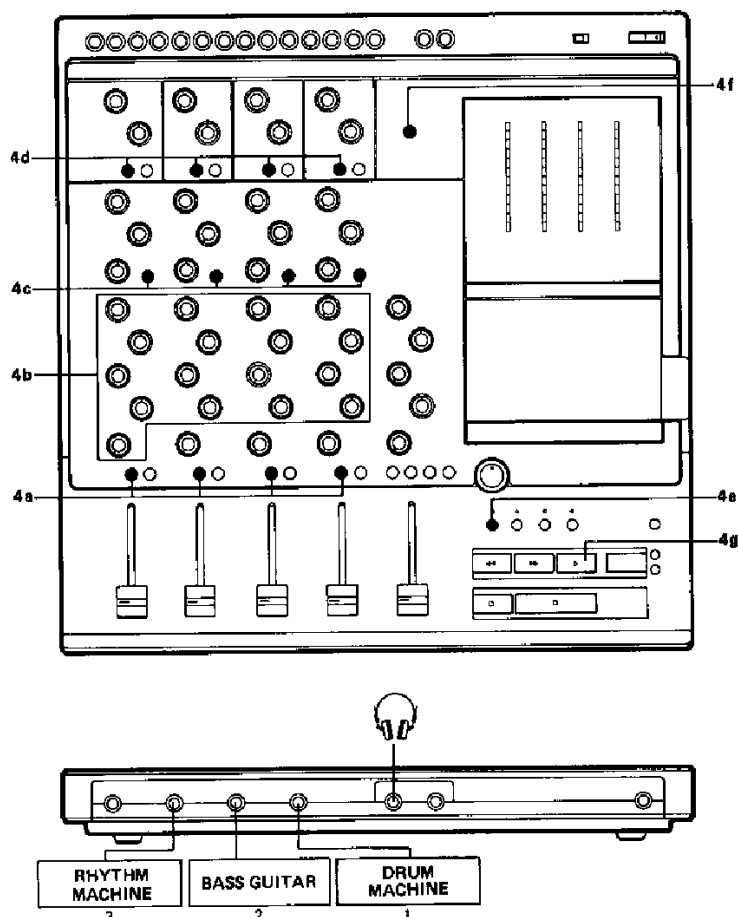

h. Listen carefully for the desired balance when you play it back. If you think you'll need more bass, for one example, by the time the other parts are added, then just go back and mix it again. But if you think you'll need a fatter snare sound, for another example, then go back and re-record the drum track (4) now.

When tracks are mixed together, sometimes it's impossible to emphasize a particular instrument, even with parametric EQ.

5. Track 1 now contains all the basic rhythm parts. Now, let's say you're ready for background vocals. Record two separate parts on Tracks 3 & 4 (re-recording over previous tracks).
6. Then transfer Tracks 3 & 4 onto Track 2, while simultaneously adding a third background vocal part, similar to the procedure in Step 4, above.
7. Now record the primary lead instrument on track 4, and the lead vocal on track 3. These two tracks are first generation; tracks 1 & 2 (7 separate parts) are second generation.
8. Connect an external deck and mix these 9 parts to stereo.

Example 2: Single musician with synth.

1. Record 3 separate voices on Tracks 4, 3 & 2.
2. Transfer to Track 1 while adding another part (4 parts total).
3. Record 2 more voices on tracks 4 and 3 (erasing previous tracks).
4. Transfer to Track 2 while adding another part (3 parts total).
5. Record still another voice on Track 3.
6. Transfer to Track 4 while adding another part (2 parts total).
7. Record the final part (main melody) on Track 3 (1 part).
8. You now have ten parts on 4 tracks, ready to mix to stereo.

Example 3: Single musician with multiple synths and sequencer.

1. Record a "SYNC to TAPE" signal on Track 4. You don't have to turn off the Dolby C noise reduction. In fact, you don't have to leave a "guard" track for data — even SMPTE code.

Note: The sequencer must have a TAPE SYNC Output; if it does not, use an interface device like the Fostex TS-15 so that the SYNC signal is "Readable" by the tape recorder.

2. Connect the output of Track 4 (34) to the sequencer. Use the recorded MIDI signal to control the sequencer as you record rhythm and/or background parts on Tracks 1, 2 and 3.
3. Up to six parts (three stereo parts) can be recorded on each track via the six inputs. If there is a lead vocal, save one of the tracks for it.
3. Now connect the MONMIX outputs (33), to Buss In (28).
4. Via the sequencer, two stereo synths (4 mono) can now be connected to the 260's Line Inputs (32), with input and assign controls set to send everything to the stereo buss.
5. Again using Track 4 as the control reference for the

sequencer, your 260 can simultaneously mix 3 pre-recorded tracks from the recorder with 4 live channels through the mixer directly to the stereo buss. Connect a mixdown recorder to the stereo outputs (31), and record the mix.

It's always best to determine the recording sequence ahead of time, planning overdubs and ping-pong

combinations in advance. The key thing to keep in mind as you bounce tracks, is that the submix will act as a single unit during the final mixdown.

The Fostex MN-50 5 x 1 line level mixer has a Built-in compressor and is ideal for bouncing and combining tracks.

SECTION 7. STEREO RECORDING

There was a time when the term, "stereo," had only one meaning. Purists will insist that nothing has changed since. Others are more relaxed with the application of the term, and use it to refer to a variety of stereo-like program sources, each valid in its own right.

True Stereo. Two microphones only during recording, carefully placed, and two reciprocal channels of playback.

Multi-Mono. Monophonic sources are recorded individually, at various times, mixed into sub-groups, then re-mixed within a simulated stereo sound spectrum. This is the way most recordings are made.

Example 1. True Stereo.

See Pages 5 to 6 for steps on stereo recording, substituting microphones for the line level sources. Suppose this stereo source is now recorded on tracks 3 & 4. You want to make a transfer while adding another part, a vocal, say.

- Record Track Select (22) 3 & 4 off, 1 & 2 on.
- Set Input Select (3) to TRK 3 & TRK 4, INPUT for 1 & 2.
- Set all 4 Pan Select (6) buttons to MIX.
- Set REC INPUT Selectors to LEFT for 1 & 3, RIGHT for 2 & 4.
- Set Meter Select (11) to MIXER.
- Set MONITOR/PHONES (13) Select to STEREO.
- Connect two microphones to Input Jacks (35) 1 & 2, and adjust for level, EQ and Pan.

NOTE: One microphone will, of course, work as well. The attempt here was to preserve stereo imaging of the vocal against the track.

- Set the Stereo Pan Control (7) full Left for 3, full Right for 4.
- Cue the tape, set AUTO STOP (21), and record, over and over, if necessary, until you get the take you like. The composite is now on tracks 1 & 2, the original stereo track on 3 & 4.

Example 2. "Stereo Plus."

Your 260 is particularly well-suited for this application because of the additional inputs.

- Use channels 1 & 2 (35) for the main stereo microphones. Select INPUT (3), MIX (6) and LEFT (9) for Channel 1; INPUT (3), MIX (6) and RIGHT (9) for Channel 2.
- Use channel 3 for a solo mic and select TRK 3 (22), by-passing the stereo buss.
- Use Channel 4 as a touch-up mic (bass amp) and select TRK 4 (22), by-passing the stereo buss.
- Use Line Inputs 5 & 6 (32) for mono feeds (keyboard, guitar) which can be individually controlled for Pan and Gain (7) before assignment to the stereo buss.
- Use the Buss Inputs for an outboard stereo submix, like drums, whose output level can be adjusted.
- Set the Meter Select to RECORDER.
- Set the MONITOR/PHONES to STEREO.

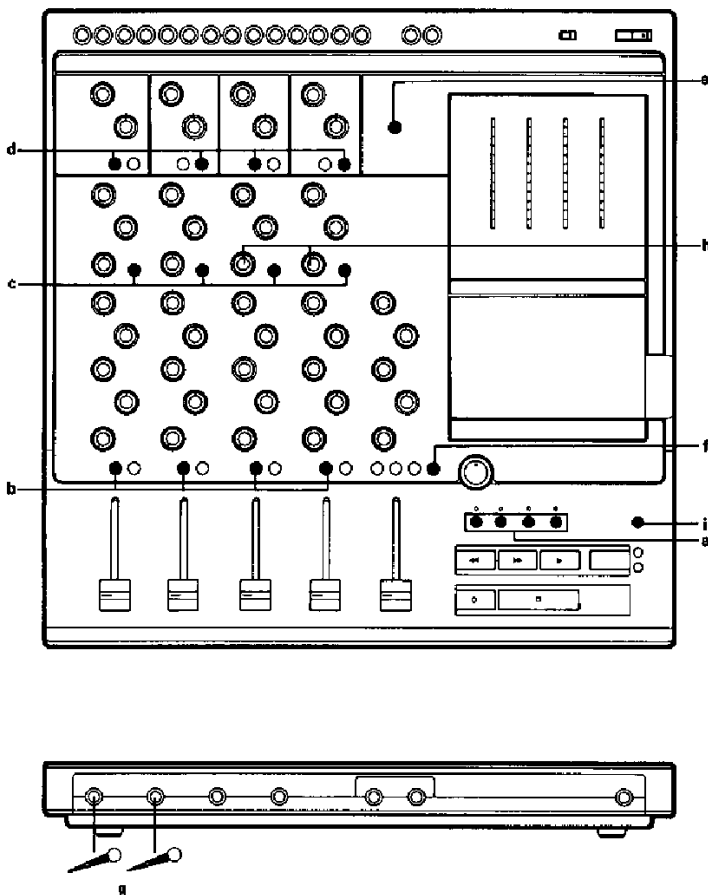

- h. Engage all 4 RECORD TRACK Select buttons.
- i. You now have three stereo pairs on the stereo buss (Tracks 1 & 2):

- Channels 1 & 2 — live mics
- Line Inputs 5 & 6 — synth, guitar
- Buss In L & R — drum submix

and two independent tracks:

- Solo Mic on Track 3 — vocals, acoustic instrument
- Touch-up Mic on Track 4 — bass amp

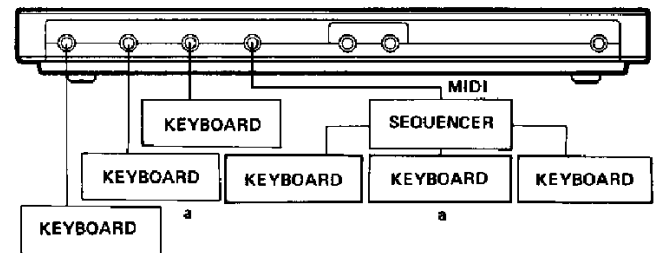
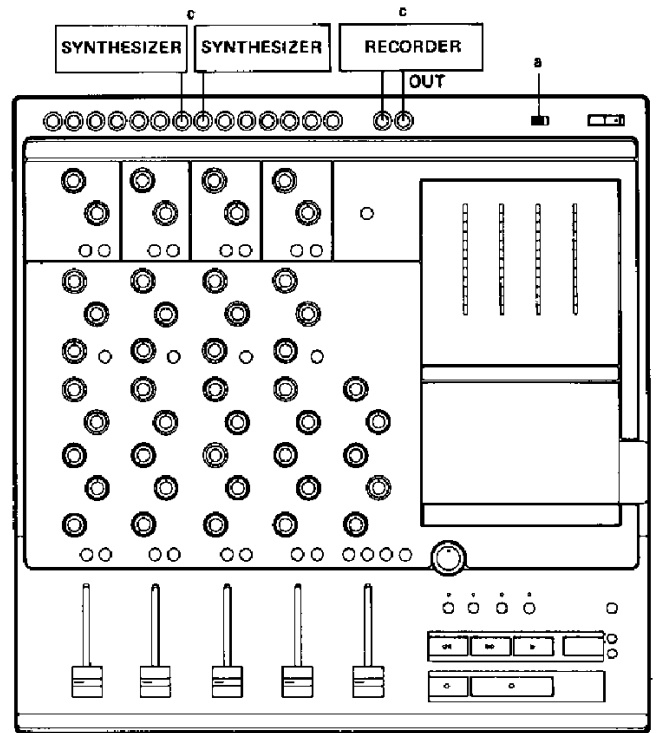
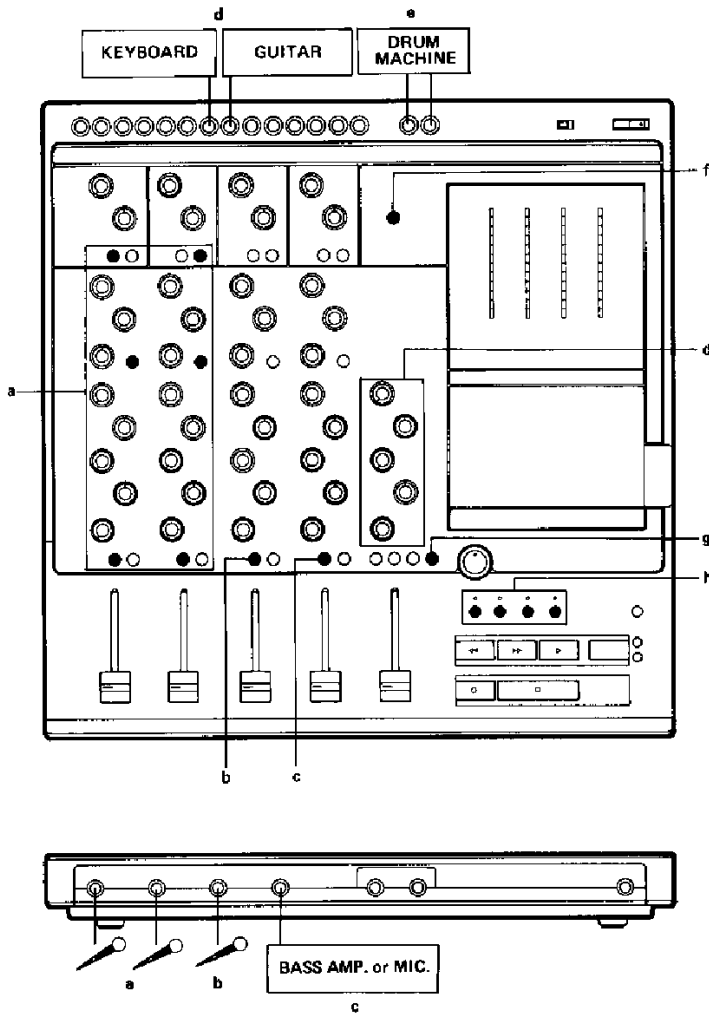

Mixing Multi-Mono within the Stereo Panorama.

Once you allow variations of the "True Stereo Reference," all sorts of artistic possibilities present themselves. In a basic assembly, the Pan control is used for Left-to-Right placement, and a reverb unit like the Fostex 3180 is used to re-create the Front-to-Back dimension.

With the Fostex M22RP Stereo Microphone, you can record the source on 3 tracks (left, right & middle), then later decode the signal from 180° spread all the way to mono, without any phase irregularities.

In more complex assemblies, different stereo references are mixed together. The drums, for example, might occupy the entire spread, so that the hi-hat or crash/ride cymbal is extreme Right, the lowest tom, extreme Left, kick drum in the center. Another stereo reference — like a piano — might be mixed in between the stereo drum spread. The final sources — like lead vocal and lead solos — are placed in the center.

In some multitrack-mono assemblies, the actual stereo references are each a vast departure from the true reference, yet mixed as they are, they create yet another reference, valid in itself. In other words, if you like the sound, use it.

Example 3. Multi-Mono.

The following set-up is becoming more and more popular:

- a. Record your MIDI (TAPE SYNC) control signal on track 4. Leave the Dolby C noise reduction on.
- b. Use this control track to trigger a sequencer which, in turn, synchronizes playback from up to three synths. These signals can be recorded on track 1, 2 and 3.
- c. Up to two more synths can be synchronized through the line input channels, simultaneously reproducing the tape signals on the Stereo Master Buss.
- d. Up to 20 separate parts may thus be assembled for a final stereo mix. Refer to Example 3, Ping-pong Recording for details.

SECTION 8. Punch-in Recording (Inserts)

This is a useful technique for correcting minor mistakes on a track, thus saving you the trouble of recording the whole track over again.

An insert is very much like an overdub in that you listen to previously recorded parts while recording a new part. The essential difference is that while an overdub is accomplished on an another track, a punch-in is recorded over a portion of the *same* track.

Timing is therefore critical. Wherever the insert occurs, previously recorded material will be erased. If you punch-in too soon or punch-out too late, you end up ruining the very track you're trying to fix.

Your 260 is especially well-suited for punch-in recording because the monitor section allows you to listen to MONMIX and STEREO OUT simultaneously.

Here's a typical example: You've just finished a bass track on 2, and everything is perfect except for a bad note in the middle of the second chorus.

1. Leave the record track selectors and input level controls where they were during the first recording. You don't want a level shift for the insert — you don't want anyone to know that there was an insert.
2. Select both MONMIX and STEREO for the Monitor/Phones (13).
3. Set the Monmix Pan and Gain controls for the best mix in the headphones.
4. Select TRK 2 for the Pan Select Control (7).
5. Set the Meter Select Button (11) to RECORDER.
6. All REC INPUT Select (9) buttons up.
7. Press RECORD TRACK Select (22) button 2.
8. Now press PLAY> and rehearse the punch-in, listening to both the prerecorded part along with the Input signal. In our example, the bad note occurs in the second chorus. A good operating technique would be to find the beginning of the second chorus, plan to punch-in there, and plan to punch-out at the end of that chorus. Re-doing a coherent section is usually much easier than trying to replace a note or two. Plus, if the insert is timed to coincide with major downbeats, any minute timing deviations will be masked.
9. You're now ready to record the insert. Except maybe your hands will be busy playing the bass. Fortunately, the 260 is equipped with a Remote jack (37) which accepts the optional Model 8051, a foot operated remote punch-in/out unit.
10. Punch-out can also be accomplished by simply stopping the tape.

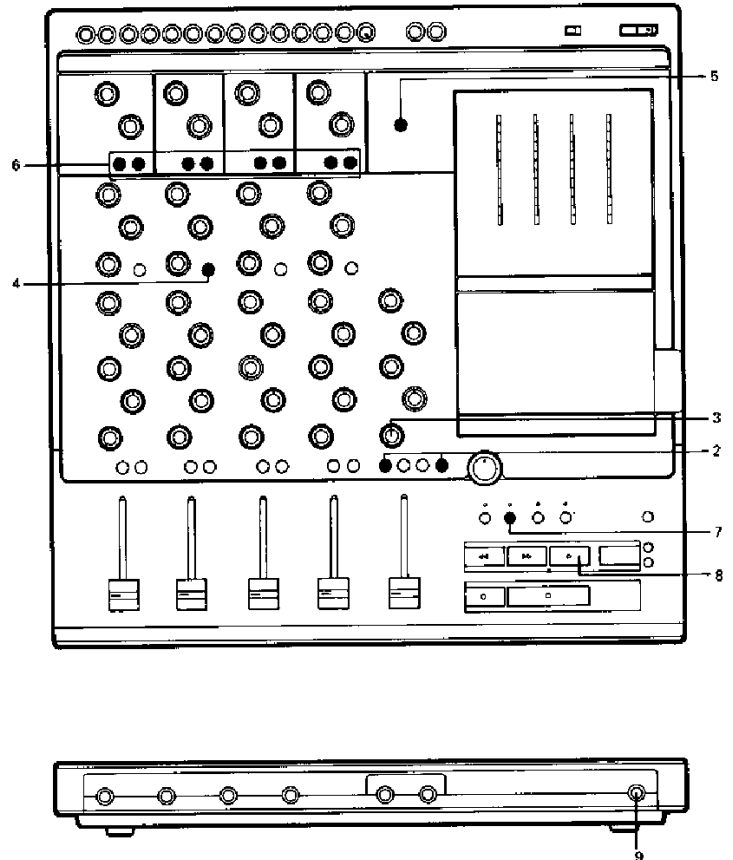

SECTION 9. INTERFACE SUGGESTIONS.

There is no "right" way to hook-up the 260. It all depends on what you want to do with what you have on hand. But perhaps we can save you some grief with the following general suggestions:

- Any equipment with pin jack connectors (Hi-Fi standard) will interface easily with the 260.
- Equipment with phone jack connectors (music standard) will also interface easily with the 260, but adapters/adaptor cables may be necessary.
- Equipment (other than microphones) with XLR-type three-pin connectors (studio/broadcast standard) will not interface easily with the 260; typically, they require outboard converters like the Fostex 5030 for proper interface.
- Some microphones, such as the Fostex RP Series, require XLR to 1/4 Phone adapters or the 1030 matching transformer for proper interface with the 260.
- MIDI data is difficult for all the recorders to read. If you have a problem, try adjusting the record level to "-10."

- Be careful in your use of "Y" adapters. Know what you're doing. Never connect outputs to outputs, for example.
- For best results in using the remote foot control function, use the Fostex Model 8051 Foot Switch.
- Fostex T-20 Headphones are excellent monitoring devices and are preferred by many studio musicians.
- Fostex 6301B Self-Powered Monitors are a great in-the-field reference. For superb stereo imaging during final mixdown, the Fostex RM Series are highly recommended.
- The cable you use may have an effect on the tapes you make. Use low capacitance cable such as the Fostex color-coded pairs, 8840~8843 (U.S.A. only), multitrack bundles 8041~8043 and snakes, 8044~8048.
- Try to keep your AC lines away from mic cable, and keep small magnetic fields — speakers, guitar pick-ups, headphones — away from the recorder.
- An attempted connection which results in an impedance or level mis-match may require an additional unit for proper interface.

SECTION 10. ROUTINE MAINTENANCE

Common sense says that you keep your 260 dry and clean, free of dust, that you avoid shocks and extremes in temperature. What you may not know is that all tape recorders require special cleaning. It's just a matter of physics: as the tape passes over the heads & guides, magnetism builds up and tape oxide is left behind.

After a short while, this build-up of oxide residue becomes visible. The increased magnetism does not. If left unchecked, the recorder degenerates from impaired to permanently damaged.

Just a few minutes a day of routine cleaning will keep your 260 working in top operating condition, giving you all the sound you paid for.

Use Fostex Cleaners Model 9600 or isopropyl alcohol on the heads, guides and capstan shaft. Cotton swabs are great. Use Fostex Model 9600 or an equivalent rubber cleaner on the pinch roller. Never use isopropyl alcohol on rubber parts because they will dry and crack.

Clean all parts indicated. Be careful with the heads. You don't want to scratch them.

After cleaning, allow the surfaces to dry before inserting a cassette. A canister of compressed air is a great way to keep the cassette compartment dry and dust-free.

To demagnetize (degauss) you need a unit like the Fostex HD-10. Follow the instructions that come with the unit. The following process is fairly standard:

1. Turn the 260 Off and remove any tape from the area.
2. Turn the demagnetizer on at a distance of three feet (one meter) from the 260.
3. Slowly bring the probe close to the head, begin moving the probe up and down, increasing the arc as you gradually pull away.
4. Turn the demagnetizer off at a distance of three feet (one meter) from the 260.
5. Repeat the process for all other metal parts in the tape path.

Do yourself a favor and set aside a time for cleaning your 260. Do it every day — every four hours if you're really using it hard. With a schedule like this, you'll never have to spend more than a few minutes each time, and your 260 will always be ready to perform its best.

If schedules make you sad, then just remember to clean and demagnetize before any recording or mixing session.

SECTION 11. SPECIFICATIONS

INPUT (x4)

Mic impedance	10K Ω or less
Input impedance	50K Ω
Nominal input level Mic:	-60dBV (1mV)
Nominal input level Line:	-10dBV (0.3V)
Min. input level	66dBV (0.5mV)
Max. input level	+12dBV (4V)

LINE IN (x2)

Input impedance	20K Ω
Nominal input level	-10dBV (0.3V)
Max. input level	+20dBV (10V)

BUSS IN (x2)

Input impedance	20K Ω
Nominal input level	-10dBV (0.3V)
Max. input level	+15dBV (5.6V)

STEREO OUT/MONITOR OUT/AUX SEND

Output load impedance	10K Ω or more (5K Ω minimum)
Nominal output level	-10dBV (0.3V)
Max. output level	+12dBV (4V)

TAPE OUT (x4)

Output load impedance	10K Ω or more
Nominal output level	-10dBV (0.3V)
Max. output level	+12dBV (4V)

HEADPHONE OUTPUT (stereo)

Load impedance	8-40 Ω (4 Ω minimum)
Maximum output	100mW at 8 Ω

EQUALIZER

80Hz ~ 1.2KHz, \pm 15dB
700Hz ~ 10KHz, \pm 15dB

RECORDING TAPE

Compact cassette, C-60 or C-90.
Use a gamma-ferric oxide tape that requires high bias level and 70 microsecond EQ (TDK Sa, Maxell X-II or equivalent).

RECORD TRACKS

4 track, one direction (Special format)

RECORD CHANNELS

4 with Dolby NR C-type in encode mode throughout (encode/decode switchable).

PLAYBACK CHANNELS

4 with Dolby NR C-type in decode mode throughout (encode/decode switchable).

NORMAL TAPE SPEED

3-3/4 ips, \pm 1%

PITCH CONTROL

\pm 15% of normal tape speed

RECORDING TIME

15 minutes for C-60

HEAD

4 channel erase (ferrite)
4 channel record/playback (Permalloy)

MOTORS

One FG servo controlled DC capstan motor and one DC reel motor.

WOW AND FLUTTER

\pm 0.1% peak (IEC/ANSI weighted) measured with flutter test tape.

FAST WIND TIME

100 seconds for C-60

FREQUENCY RESPONSE

Mixer section

Mic: 20Hz ~ 18KHz, 0/-2dB
Line: 20Hz ~ 20KHz, 0/-1dB

Recorder section

40Hz ~ 18KHz, +2/-3dB at 0VU

T.H.D.

Mixer section

0.07% at 1KHz

Recorder section

2.0% at 1KHz, 0dB level (overall)

S/N

Mixer section

One mic in overall 65dB weighted
63dB unweighted
One line in overall 80dB weighted
75dB unweighted

Recorder section

70dB weighted
55dB unweighted
Referenced to 3% THD level

CROSSTALK

Mixer section

65dB at 1KHz

Recorder section

50dB at 1KHz

ERASURE

70dB at 1KHz

POWER REQUIREMENTS

120V AC, 60Hz, 22W
220V AC, 50Hz, 24W
240V AC, 50Hz, 24W

DIMENSIONS

95(H) x 420(W) x 415(D)mm
[3-3/4(H) x 16-1/2(W) x 16-3/8(D)]

WEIGHT

Net 6.2Kg, (13.6 lbs.)

Specifications subject to change without notice.

**Dolby noise reduction manufactured under license from Dolby Laboratories Licensing Corporation. "Dolby" and the double-D symbol are trademarks of Dolby Laboratories Licensing Corporation.*

SECTION 12. BLOCK DIAGRAM

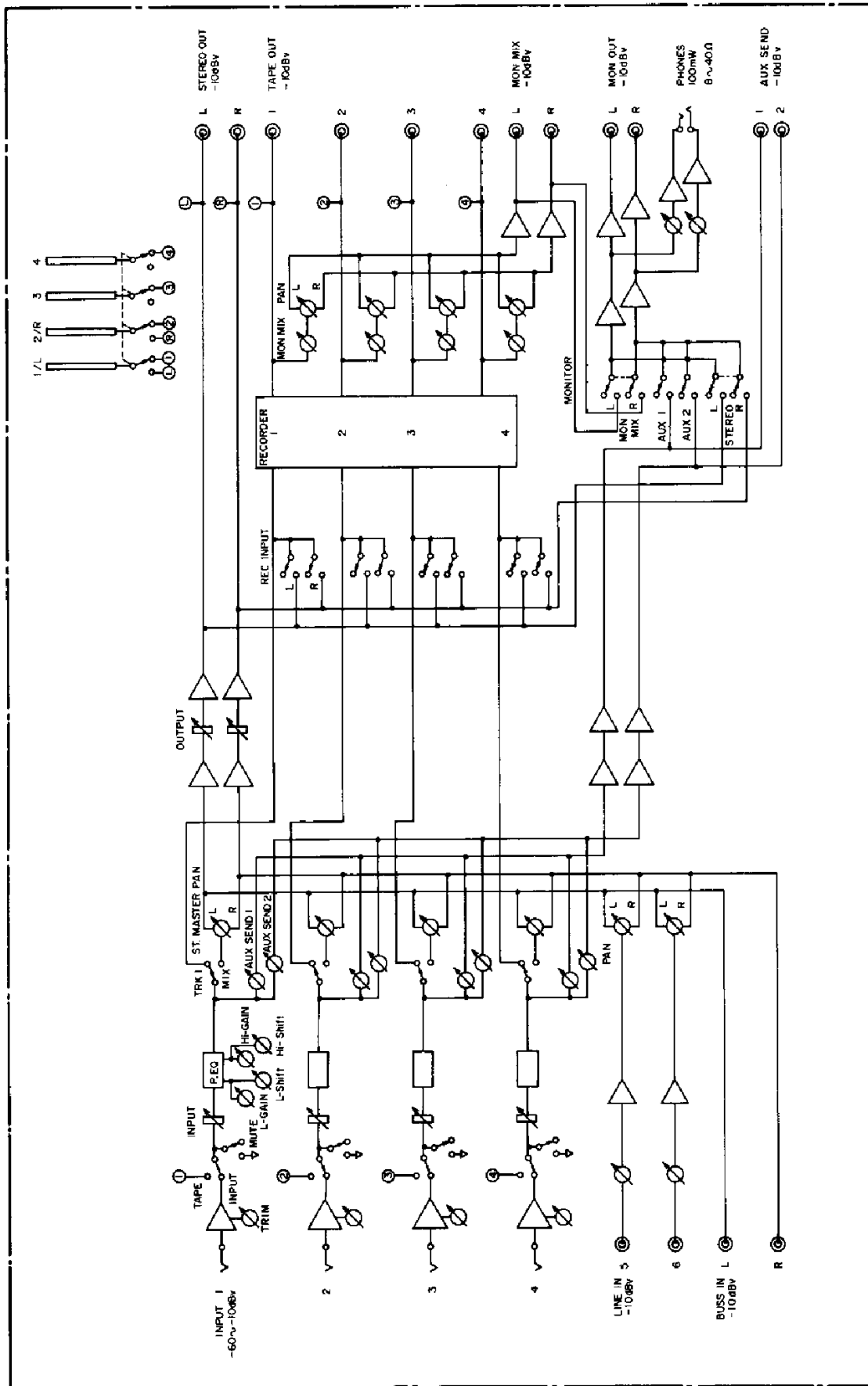

FOSTEX INFORMATION SERVICE

*HELPFUL HOW TOs AND PRACTICAL GUIDES
FOR MUSICIANS AND SONGWRITER*

BASIC DISC MASTERING

Larry Boden \$10.95

Really detailed and technical, but clear. Lots of illustrations help make it easy to follow. 52 pages, 1981.

THE PLATINUM RAINBOW

*Bob Monaco &
James Riordan \$9.95*

Knowledgeable and enthusiastic. They share their enthusiasm and information so well that this recent 212 page book is used as a text in dozens of colleges, 1983.

BREAKIN*IN TO THE MUSIC BUSINESS

Alan H. Siegel \$8.95

Encouraging, optimistic, practical — one of the premier lawyers in the field helps you ask the right questions and get the right answers. Illustrations, 274 pages, 1983.

THE MODERN RHYMING DICTIONARY

Gene Lees \$14.95

Lees knows and loves lyrics; he's been writing and selling them for years. Lots of insights, plus a comprehensive rhyming dictionary which even includes a list of words for which there are no rhymes. 360 pages, 1981.

MAKING MUSIC

George Martin \$10.99

A definitive book, given worldwide praise for its comprehensiveness and clarity. Martin, of course was the first producer of the Beatles, 352 pages, 1983.

BUILDING A RECORDING STUDIO

Jeff Cooper \$30.00

All you want and need to know about acoustical design and engineering, and soundproofing — by the licensed architect whose clients include Warner Studios and George Lucas. 209 pages, more than 100 illustrations, 1984.

HOME RECORDING FOR MUSICIANS

*Craig Anderton
\$14.95*

Half technical, half general, all helpful. Anderton is a critic and enthusiast. Lots of illustrations; includes a demo record. Foreward by Brittain's George Martin. 182 pages.

HOW TO MAKE AND SELL YOUR OWN RECORD













*Diane Rapaport
\$12.95*

In 192 bright, breezy fact-studded pages, Ms. Rapaport gives you a solid handle on the critical business side of the music business. Lots of charts, tables, check sheets, lists of important addresses. 1984.

Figure Blank log sheet for reproduction

TAPE No.:		SONG/TITLE:		START DATE:		END DATE:		NOTE ALL PERFORMERS ON BACK OF THIS SHEET	
INITIAL TAKE & OVERDUBS									
REF. NO.	TAPE INDEX COUNT	PROGRAM ON EACH TRACK OF TAPE				COMMENTS/NOTES			
		TRACK 1	TRACK 2	TRACK 3	TRACK 4				
		RECORD TRACK	RECORD TRACK	RECORD TRACK	RECORD TRACK	RECORD TRACK SELECTOR SETTINGS FOR INITIAL TRACK ASSIGNMENT.			

TRANSFERS/TRACK COMBINATION						
REF. No.	INDEX COUNT	PROGRAM TRANSFERRED ONTO EACH TRACK OF TAPE				COMMENTS/NOTES
		TRACK 1	TRACK 2	TRACK 3	TRACK 4	

SETUP FOR REMIX TO STEREO (OR MONO)							
TRACK No.	CHAN. FADER	EQUAL		2 CHAN (1-2) PAN	EFFECTS PATCH AUX OUT- ? -AUX	AUX RCV	COMMENTS
					LEFT		
					RIGHT		
							
							

SAFETY INSTRUCTIONS

WARNING

“READ BEFORE OPERATING”

1. **Read Instructions**—All the safety and operating instructions should be read before the appliance is operated.
2. **Retain Instructions**—The safety and operating instructions should be retained for future reference.
3. **Heed Warnings**—All warnings on the appliance and in the operating instructions should be adhered to.
4. **Follow Instructions**—All operating and use instructions should be followed.
5. **Water and Moisture**—The appliance should not be used near water—for example, near a bathtub, washbowl, kitchen sink, laundry tub, in a wet basement, or near a swimming pool, etc.
6. **Ventilation**—The appliance should be situated so that its location or position does not interfere with its proper ventilation. For example, the appliance should not be situated on a bed, sofa, rug, or similar surface that may block the ventilation openings; or, placed in a built-in installation, such as a bookcase or cabinet that may impede the flow of air through the ventilation openings.
7. **Heat**—The appliance should be situated away from heat sources such as radiators, heat registers, stoves, or other appliances (including amplifiers) that produce heat.
8. **Power Sources**—The appliance should be connected to a power supply only of the type described in the operating instructions or as marked on the appliance.
9. **Power-Cord Protection**—Power-supply cords should be routed so that they are not likely to be walked on or pinched by items placed upon or against them, paying particular attention to cords at plugs, convenience receptacles, and the point where they exit from the appliance.
10. **Cleaning**—The appliance should be cleaned only as recommended by the manufacturer.
11. **Nonuse Periods**—The power cord of the appliance should be unplugged from the outlet when left unused for a long period of time.
12. **Object and Liquid Entry**—Care should be taken so that objects do not fall and liquids are not spilled into the enclosure through openings.
13. **Damage Requiring Service**—The appliance should be serviced by qualified service personnel when:
 - A. The power-supply cord or the plug has been damaged; or
 - B. Objects have fallen, or liquid has been spilled into the appliance; or
 - C. The appliance has been exposed to rain; or
 - D. The appliance does not appear to operate normally or exhibits a marked change in performance; or
 - E. The appliance has been dropped, or the enclosure damaged.
14. **Servicing**—The user should not attempt to service the appliance beyond that described in the operating instructions. All other servicing should be referred to qualified service personnel.

Fostex

FOSTEX CORPORATION 560-3, Miyazawa-cho, Akishima, Tokyo, Japan

FOSTEX CORPORATION OF AMERICA 15431, Blackburn Ave., Norwalk, CA 90650, U.S.A.

©PRINTED IN JAPAN JUL. 1996 8288 1120 00