

# *Digital Portable Mixer*

---

## **Operating Instructions**

Before operating the unit, please read this manual thoroughly and retain it for future reference.

## **DMX-P01**

## Owner's Record

The model and serial numbers are located on the rear. Record the serial numbers in the spaces provided below. Refer to them whenever you call upon your Sony dealer regarding the product.

Model No. DMX-P01

Serial No. \_\_\_\_\_

## WARNING

**To prevent fire or shock hazard, do not expose the unit to rain or moisture.**

**To avoid electrical shock, do not open the cabinet. Refer servicing to qualified personnel only.**

### For the customers in the U.S.A.

This equipment has been tested and found to comply with the limits for a Class A digital device, pursuant to Part 15 of the FCC Rules. These limits are designed to provide reasonable protection against harmful interference when the equipment is operated in a commercial environment. This equipment generates, uses, and can radiate radio frequency energy and, if not installed and used in accordance with the instruction manual, may cause harmful interference to radio communications. Operation of this equipment in a residential area is likely to cause harmful interference in which case the user will be required to correct the interference at his own expense.

You are cautioned that any changes or modifications not expressly approved in this manual could void your authority to operate this equipment.

The shielded interface cable recommended in this manual must be used with this equipment in order to comply with the limits for a digital device pursuant to Subpart B of Part 15 of FCC Rules.

### For customers in Canada

This class A digital apparatus complies with Canadian ICES-003.

### For the customers in Europe

This product with the CE marking complies with the EMC Directive (89/336/EEC) issued by the Commission of the European Community.

Compliance with these directives implies conformity to the following European standards:

- EN55103-1: Electromagnetic Interference (Emission)
- EN55103-2: Electromagnetic Susceptibility (Immunity)

This product is intended for use in the following Electromagnetic Environment(s):

E1 (residential), E2 (commercial and light industrial), E3 (urban outdoors) and E4 (controlled EMC environment, ex. TV studio).

### Voor der Klanten In Nederland

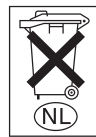

Gooi de batterij niet weg maar lever deze in als klein chemisch afval (KCA).

# Table of Contents

<b>Overview .....</b>	<b>4</b>	12. HOURS METER	
<b>Precautions .....</b>	<b>5</b>	Sub-Menu .....	33
<b>Using the CD-ROM Manual .....</b>	<b>6</b>	13. POWER ON MODE	
CD-ROM System		Sub-Menu .....	33
Requirements .....	6	<b>Using the Unit to a</b>	
Preparations .....	6	<b>Camcorder .....</b>	<b>34</b>
Reading the CD-ROM Manual ...	6	Connecting a Camcorder .....	34
<b>Location and Function of</b>		Checking the Status of a	
<b>Parts and Controls .....</b>	<b>8</b>	Connection .....	35
Front Panel .....	8	<b>Miscellaneous .....</b>	<b>38</b>
Left Panel .....	13	Preparing a Power Supply .....	38
Right Panel .....	15	Inserting the Batteries in the	
<b>Connections .....</b>	<b>18</b>	Battery Compartment .....	38
Basic Connection .....	18	Replacing a Meter Scale	
Cascade Connection .....	19	Sheet .....	41
<b>Display in the Display Mode... 20</b>		Troubleshooting .....	42
<b>Settings from the Setup</b>		Pin Assignments of	
<b>Menu .....</b>	<b>22</b>	Connectors .....	44
Setup Menu Structure .....	22	<b>Specifications .....</b>	<b>46</b>
Basic Menu Operation .....	24	<b>Block Diagram .....</b>	<b>48</b>
1. SCENE RECALL			
Sub-Menu .....	26		
2. SCENE STORE Sub-Menu ..	27		
3. CAMERA RETURN			
Sub-Menu .....	28		
4. LCF Sub-Menu .....	28		
5. CH LINK/M-S Sub-Menu ....	29		
6. INPUT LIMITER			
Sub-Menu .....	29		
7. OUTPUT COMP L			
Sub-Menu/8. OUTPUT			
COMP R Sub-Menu .....	30		
9. PARAMETER LOCK			
Sub-Menu .....	31		
10. PANEL LOCK Sub-Menu ..	32		
11. METER SELECT			
Sub-Menu .....	32		

# Overview

The DMX-P01 is a portable digital mixer designed for professional electronic news gathering (ENG) and electronic field production (EFP). The DMX-P01 has a compact, lightweight body designed to be used in field production, making it ideal for use with digital video and audio recording media such as a camcorder and microphones, and so on.

The DMX-P01 has the following features.

---

## High quality audio signal processing

The unit allows you to select a sampling frequency of either 48 kHz or 96 kHz

The unit converts an analog signal to a 24-bit digital signal and outputs an AES3 format (AES/EBU connector) or an IEC60958 format (S/PDIF coaxial connector) digital audio signal. This enables to record the sound with excellent sound quality using digital peripheral equipment such as a portable recorder corresponding to an 96-kHz sampling frequency.

---

## 4 microphone/line inputs/2 balanced outputs

The unit is equipped with 4 microphone/line inputs and 2 outputs, all with XLR type balanced connectors. Furthermore, digital AES/EBU output (stereo) with XLR connectors and IEC60958 format digital output with a coaxial connector are provided.

---

## Digital cascade

Since the unit is equipped with coaxial input/output connectors, DMX-P01 mixers can be cascaded using one coaxial cable, for applications requiring additional inputs.

---

## LCD panel for various displays and easy setup

The LCD panel enables the unit to display the level meter, battery remaining amount, or cumulative time in use.

The level meter can be easily chosen from among a VU, a dBFS or four types of PPM meters.

Setup menus displayed on the LCD allow to easily change various parameter settings.

Also, since a heater is built into the LCD, the heated LCD displays normally, even at low temperature.

---

## High quality digital limiters/compressors

The unit is equipped with digital limiters at the input and both digital compressor/limiters at the output. Using these features, the unit can provide highly stable audio recording.

---

## Scene storing/recalling

The unit allows to store up to ten different parameter settings such as panel-lock, parameter lock, and so on, as a scene file. Recalling the desired scene file switches the operating parameters of the unit immediately.

---

## **Full parameter controls on the front panel similar to those of analog mixers**

Controls and switches are logically laid out on the front panel to allow fast, easy and accurate setting adjustments. Also, the panel-lock function prevents you from operating the unit accidentally.

---

## **Solid and lightweight**

Since the unit is compact and lightweight, you can carry it easily. Also, its solid design enables it to stand work in the field.

# Precautions

- The unit is designed for use in ambient temperature range of 0°C to 45°C (32°F to 113°F).
- Do not place the unit on or near heat sources, such as lighting equipment, power amplifiers, or in a place subject to direct sunlight or excessive moisture. In such places, the external finish or internal parts of the unit may be damaged.
- If the unit is used in a very humid or dusty place or in a place subject to an active or corrosive gas, clean it surface as well as the connectors with a dry, soft cloth soon after use. Lengthy use of the unit in such places or not cleaning it after its use in such places may shorten its life.
- When cleaning the unit, never use organic solvents such as thinner or benzene, which will damage the finish of the unit.
- The unit has been factory adjusted precisely. Do not tamper with its internal parts or attempt to repair it.

# Using the CD-ROM Manual

The supplied CD-ROM includes operating instructions (Japanese, English, French, German, Italian, Spanish and Chinese versions).

## CD-ROM System Requirements

The following are required to access the supplied CD-ROM disc.

- Computer: PC with Intel Pentium CPU
  - Installed memory: 64 MB or more
  - CD-ROM drive: ×8 or faster
- Monitor: Monitor supporting resolution of 800 × 600 or higher
- Operating system: Microsoft Windows Millennium Edition, Windows 2000 Service Pack 2, Windows XP Professional or Windows XP Home Edition

When these requirements are not met, access to the CD-ROM disc may be slow, or not possible at all.

## Preparations

One of the following programs must be installed on your computer in order to use the operating instructions contained on the CD-ROM disc.

- Adobe Acrobat Reader Version 4.0 or higher
- Adobe Reader Version 6.0 or higher

### Note

If Adobe Reader is not installed, you can download it from the following URL:

<http://www.adobe.com/>

## Reading the CD-ROM Manual

To read the operating instructions contained on the CD-ROM disc, do the following.

- 1** Insert the CD-ROM disc in your CD-ROM drive.

A cover page appears automatically in your browser. If it does not appear automatically in the browser, double-click the `index.htm` file on the CD-ROM disc.

- 2** Select and click the operating instructions that you want to read.

This opens the PDF file of the operating instructions.

---

**Note**

If you lose the CD-ROM disc or become unable to read its content, you can purchase a new CD-ROM disc to replace one that has been lost or damaged. Contact your Sony service representative.

**Trademarks**

- Intel and Pentium are registered trademarks of Intel Corporation or its subsidiaries in the United States and other countries.
- Microsoft and Windows are registered trademarks of Microsoft Corporation in the United States and/or other countries.
- Adobe, Acrobat, and Adobe Reader are trademarks of Adobe Systems Incorporated in the United States and/or other countries.

# Location and Function of Parts and Controls

## Front Panel

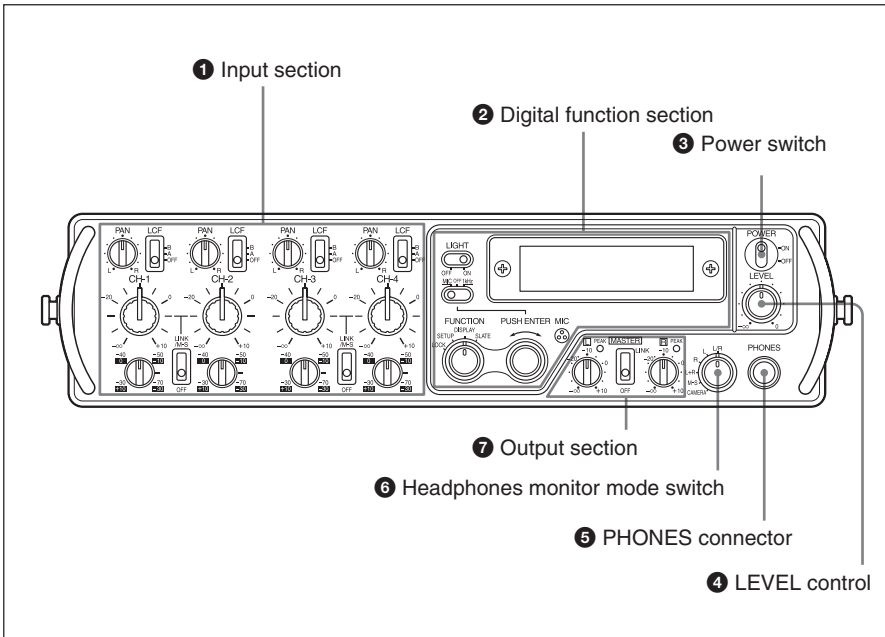

### 1 Input section

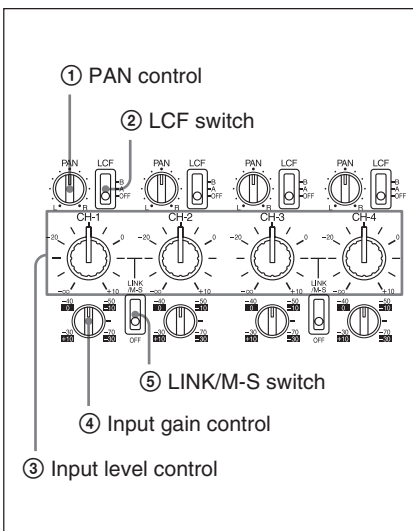

### 1 PAN control

Adjusts the mix level of the input signal sent to the Left and Right buses. The adjustable range is 0 dB to -3 dB (at the center position) to -∞.

**When the control is turned fully to the L side:** The signal is sent to the Left bus at a 0 dB gain. The signal to the Right bus is completely attenuated

**When the control is turned fully to the R side:** The signal is sent to the Right bus at a 0 dB gain. The signal to the Left bus is completely attenuated.

**When the control is placed at the center position:** A signal of -3 dB is sent to both the Left and Right buses.



## ② LCF (Low Cut Filter) switch

Selects the frequency of the low cut filter of each channel.

**OFF:** Select this position to deactivate the LCF switch.

**A, B:** A cut-off frequency between 50 and 400 Hz at 48-kHz sampling frequency and between 70 and 400 Hz at 96-kHz sampling frequency can be assigned to each position. The filter is 12 dB per octave.

The SETUP menu allows you to set the cut-off frequency.

*For detailed information, see “4. LCF Sub-Menu” on page 28.*

## ③ Input level control

Adjusts the input level of each channel. The adjustable range is between  $-\infty$  (at the fully counterclockwise position) and +10 dB (at the fully clockwise position).

The function of this control depends on the setting of the ⑤ LINK/M-S switch.

*For detailed information, see “⑤ LINK/M-S switch” on this page.*

## ④ Input gain control

Adjusts the gain of the input head amplifier of each channel.

The adjustable range depends on the setting the input select switch located on the left side of the unit.

**When the input select switch is set to LINE:** The adjustable range is enclosed in a square. The range is between +10 dB (at the fully counterclockwise position) and -30 dB (at the fully clockwise position).

**When the input select switch is set to MIC or MIC+48 V:** The range is between -30 dB (at the fully counterclockwise position) and -70 dB (at the fully clockwise position).

## ⑤ LINK/M-S switch

By setting this switch to the LINK/ M-S position, channels 1 and 2 and channels 3 and 4 can be set to either LINK mode or M-S mode.

The SETUP menu allows you to select either LINK or M-S mode.

*For detailed information, see “5. CH LINK/M-S Sub-Menu” on page 29.*

**When the switch is set to**

**LINK/M-S:**

**When LINK is selected on the 5. CH LINK/M-S sub-menu;** The

unit is in link mode. Channels 1 and 2 and channels 3 and 4 are linked and act as a stereo pair. Channels 1 and 3 are Left and channels 2 and 4 are Right. The input level control of channel 1 adjusts the input level of channels 1 and 2, and the input level control of channel 3 adjusts the input level of channels 3 and 4. In this case, the PAN control becomes a Left/Right balance control. At the center position, an impression of stereo sound can be obtained. The LCF switches of channels 1 and 3 are activated. The LCF switch of channel 1 acts as the LCF switch of channel 2, as well. Also, the LCF switch of channel 3 acts as the LCF switch of channel 4 at the same time.

# Location and Function of Parts and Controls

**When M-S is selected on the 5. CH LINK/M-S sub-menu;** The unit is in M-S mode.

Select this position for M-S decoding when an M-S microphone is used.

Connect channel 1 and channel 3 to the M side and channel 2 and channel 4 to the S side. In such a case, the input level control of the CH-1 and CH-3 act as an input level control and the input level controls of the CH-2 and CH-4 act as a phase control. Turning the phase control to the right provides an expansive feeling.

**When the switch is set to OFF:**

Controls and switches act as those of each channel, independently.

## ② Digital function section

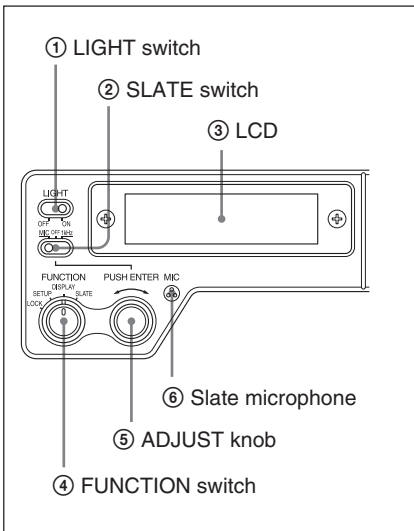

**① LIGHT switch**

Turns the light of the LCD on or off.

**② SLATE switch**

Only activates when the

**④ FUNCTION** switch is set to SLATE. Turns the slate function on or off. The slate function allows you to record the scene number or take number along with the sound at the beginning of a recording for each cut, or adjust the level using a 1-kHz reference signal when recording using a camcorder or recorder.

**MIC:** Outputs the sound to all of output connectors from the built-in condenser microphone.

**1 kHz:** Outputs a 1-kHz reference signal to all of the output connectors.

**OFF:** The slate function is disabled.

## To output the voice from the microphone or a 1-kHz reference signal

- 1 Turn the L/R MASTER volume control toward the right to increase the volume.
- 2 Set the SLATE switch to either MIC or 1 kHz.
- 3 Set the FUNCTION switch to SLATE.
- 4 Push the ADJUST knob. Output of the voice from the microphone or a 1 kHz. reference signal depends on how you press the ADJUST knob.

**When you press and hold the ADJUST knob:**

The sound or signal is output while this knob is being pressed when you release the knob, output ceases.

**When you press the knob and release it instantly:**

When you press the knob and release it instantly, the sound or signal continues to be output.

When you press the knob and release it again, output ceases.

**③ LCD (Liquid Crystal Display)**

What is displayed depends on the setting of the FUNCTION switch. For detailed information, see “④ FUNCTION switch.”

A heater is built into the LCD to be used in cold weather. This prevents the LCD from slowing down the display speed. The temperature is detected and the heater is automatically turned on or off.

**Note**

This heater is activated only with an external power supply. When the power is supplied from the batteries, the heater is not activated.

**④ FUNCTION switch**

**LOCK:** Set to this position to lock the controls and switches on the front panel to the settings at the time you set the switch to the LOCK position. Switches and controls locked are the Input level control, PAN control, LINK/M-S switch, MASTER control and MASTER LINK switch.

The PANEL LOCK sub menu of the SETUP menu allows you to decide which switches and controls are to be locked or unlocked.

**LCD in the lock mode:** Displayed in the display mode. You can select the item to be displayed by turning the ADJUST knob.

**When you operate locked switches or controls:** The following message is displayed to state that the switch or control is locked.

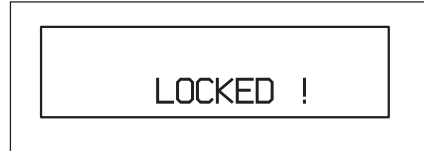

However, these switches and controls activate with the current settings when the FUNCTION switch is set to the SETUP or DISPLAY position.

**When the power is turned off with the lock setting in place:**

Switches and controls are still locked when you turn on the power again.

**SETUP:** Set to this position to set parameters.

**DISPLAY:** Set to this position to display meters. The meter to be displayed is changed in the following sequence by turning the ADJUST switch: Full size level meter → Multi meter → Input level meter for channels 1 and 2 → Input level meter for channels 3 and 4 → Information.

**SLATE:** Set to this position to use the SLATE function. The SLATE switch becomes activated. The kind of the output signal depends on the setting of ② SLATE switch.

# Location and Function of Parts and Controls

## ⑤ ADJUST (PUSH ENTER) knob

Used for menu operations. Select a menu by turning the knob and execute by pressing the knob.

When the SLATE function is on, this switch acts as the slate signal output button.

## ⑥ Slate microphone

This built-in condenser microphone is activated when the ADJUST knob is pressed.

*For detailed information on how to output voice from the microphone, see “To output the voice from the microphone or a 1-kHz reference signal” on page 10.*

## ③ Power switch

Turns the power on or off.

When the power is on, the external power supply is selected automatically when the power is supplied externally. If the internal batteries are inserted, the power supply is not interrupted even if you disconnect and re-connect the external power supply. Also, you can change the internal batteries without interrupting operations when you use the external power supply.

## ④ LEVEL control

Adjusts the headphones volume level.

## ⑤ PHONES connector (stereo phone jack)

Connects the headphones. The same signal as the one from the PHONES connector located on the right side of the unit is output.

The signal to be output depends on the setting of the ⑥ Headphones monitor mode switch.

## ⑥ Headphones monitor mode switch

Selects the signal to be monitored through the headphones.

**L/R:** Outputs the Left signal of the master output signal to the Left channel and the Right signal to the Right channel as stereo.

**L+R:** Outputs a mixed signal of the master output signal to both Left and Right channels as mono.

**L:** Outputs the Left signal of the master output signal to both Left and Right channels.

**R:** Outputs the Right signal of the master output signal to both Left and Right channels.

**M-S:** Outputs the M/S decoded signal to the PHONES connector. Select this position when the M-S (Mid-Side) microphone is used and only the output signal to the PHONES connector is to be decoded.

**CAMERA:** Outputs the signal from the camcorder input to the CAMERA connector located on the right side.

## ⑦ Output section

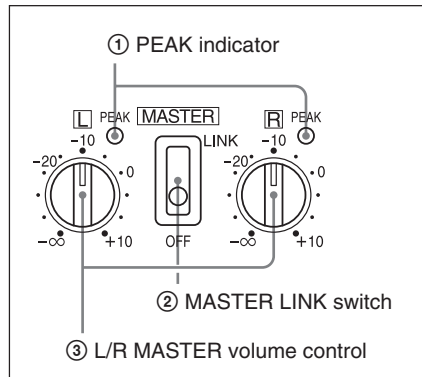

### ① PEAK indicator

Lights in red when the output signal reaches  $-3$  dB from a clipping level. When the output compressors/limiters activate, this indicator lights to indicate the compressor/limiter operations, as follows.

When the input level exceeds the preset threshold level, the output compressors activate and the indicator lights in orange.

When the input level exceeds the preset threshold level, the limiters activate and the indicator lights in red. The OUTPUT COMP L and OUTPUT COMP R sub-menus of the SETUP menu allow you to make settings of the threshold level for the compressors/limiters.

### ② MASTER LINK switch

Setting the switch to the LINK position links the Left channel output and Right channel output of the master output. The L MASTER volume control adjusts the output level of both channels. In this case, the R MASTER volume control is not activated. This function is not applied to the output compressor/limiter.

### ③ L/R MASTER volume control

Adjusts the output level. The adjustable range is  $-\infty$  dB at the fully counterclockwise position, 0 dB and  $+10$  dB at the fully clockwise position.

## Left Panel

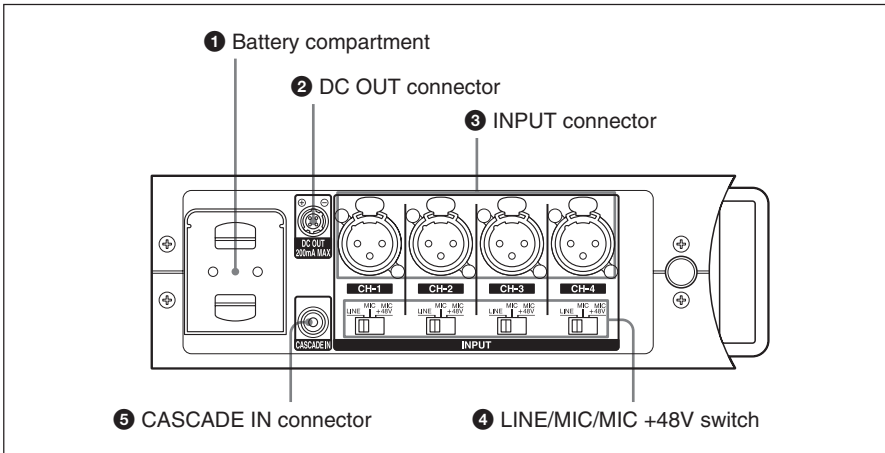

### ① Battery compartment

Accommodates eight LR6 (size AA) alkaline batteries.

### ② DC OUT connector (4-pin, female)

Supplies the power to a UHF portable tuner WRR-860A/861A/862A (option).

## Location and Function of Parts and Controls

### Notes

- Be sure not to connect devices other than a UHF portable tuner.
- The unit outputs the power, only when the unit operates with an external power supply.  
This connector outputs the power by dividing the power input via the DC IN 10-15 V connector. Thus the output voltage depends on the power input via the DC IN 10 - 15 V connector.

### ③ INPUT (analog signal input) connectors (XLR type 3-pin, female)

Input the analog audio signals of the four channels CH1, CH2, CH3 and CH4.

### ④ LINE/MIC/MIC +48V switch

Selects the position to match the incoming signal level of each channel.

**LINE:** Set to this position when connecting equipment with an input signal level between +10 dBu and -30 dBu.

**MIC:** Set to this position when connecting the equipment with an input signal between -30 dBu and -70 dBu, especially when connecting a microphone.

**MIC +48V:** Set to this position when connecting the equipment with an input signal between -30 dBu and -70 dBu, especially when connecting a DC +48V power microphone.

### ⑤ CASCADE IN (Cascade signal input) connector (Phono jack)

Used for a cascade connection. When this unit is as the second one connected, connect this connector to the COAXIAL connector located on the right panel of the first DMX-P01. This unit is synchronized with the first DMX-P01 using the master clock signal extracted from the signal of this connector.

### Note

In a cascade connection, the sampling rate of both DMX-P01 mixers must be matched. Set the sampling rate to match using the SAMPLING RATE switch.

Also, do not input the IEC60958 format signal to the CASCADE INPUT connector.

## Right Panel

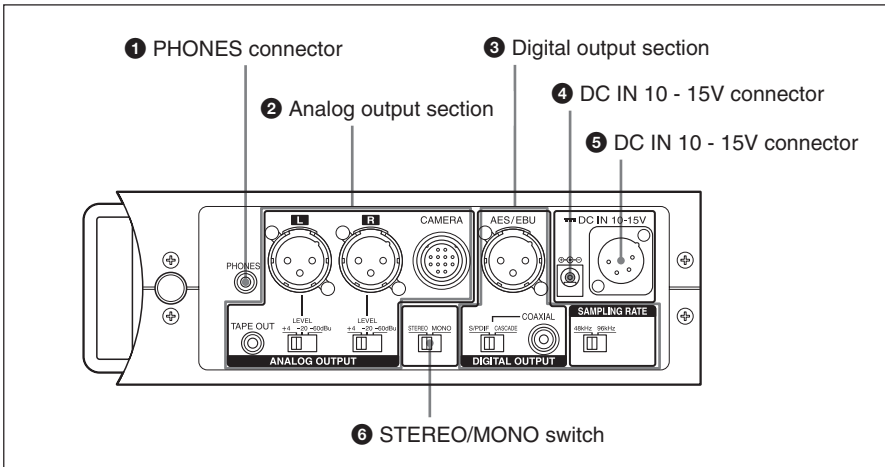

### 1 PHONES connector (3.5 mm TRS jack)

Connects the headphones. The same signal as the one output from the PHONES connector located on the front panel is output.

### 2 Analog output section

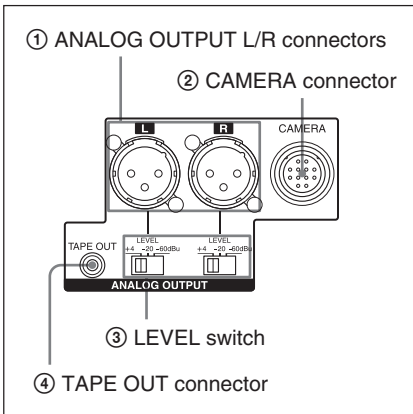

### 1 ANALOG OUTPUT L/R (analog signal output) connectors (XLR type 3-pin, male)

Outputs the Left and Right analog master signals.

### 2 CAMERA (analog signal input/output) connector (12-pin)

Connects to a camcorder. Outputs the master analog signal and inputs the return signal from the camcorder.

Make connection which matches the specifications of the camcorder using the supplied connector.

*For detailed information on the pin assignment, see "Pin Assignments of Connectors" on page 44.*

### 3 LEVEL (output level select) switch

Selects the reference level of the Left and Right analog master signals and the CAMERA output signal from among +4 dBu, -20 dBu, and -60 dBu.

# Location and Function of Parts and Controls

## ④ TAPE OUT (analog signal output) connector (3.5mm TRS jack)

Outputs an unbalanced stereo analog signal. The reference level is fixed to -10 dBu.

## ③ Digital output section

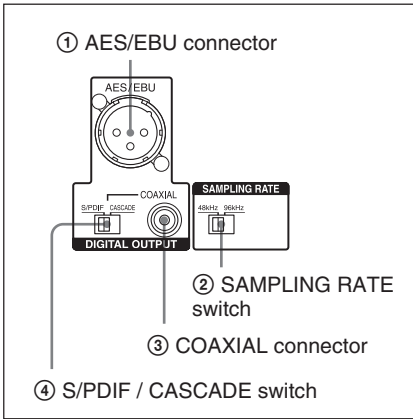

## ① AES/EBU (AES/EBU signal output) connector (XLR type 3-pin, male)

Outputs the digital master signal in AES/EBU format. Used to connect the unit to a digital recorder. The sampling frequency is the same as the one selected using the ② SAMPLING RATE switch.

## ② SAMPLING RATE (sampling frequency select) switch

Selects the sampling frequency, either 48 kHz or 96 kHz.

## Note

When you change the sampling frequency, turn the power off once, and then turn it on again. After the power is turned on again, the unit operates according to the new sampling frequency.

You can check the current sampling frequency at which the unit operates on the Information window.

*For details, see “Information” on page 21.*

## ③ COAXIAL (digital signal output) connector (Phono jack)

Outputs the digital signal in IEC60958 format. Used to connect the unit to a digital recorder or a second DMX-P01. The sampling frequency is the same as the one selected using the ② SAMPLING RATE switch.

## ④ S/PDIF / CASCADE switch

Selects the signal to be output from the COAXIAL connector.

**S/PDIF:** Outputs the same signal as the master output. Set to this position when connecting the unit to a digital recorder

**CASCADE:** Outputs the Left and Right bus signals. Set the switch to this position when connecting the COAXIAL connector to the CASCADE IN connector of the second DMX-P01 in a cascade connection for adding inputs.

## Note

When two DMX-P01 mixers are used in the cascade connection, the sampling rate of both mixers should be matched. Set the same sampling rate using the SAMPLING RATE switch.



---

**④ DC IN 10 - 15 V (external power input) connector (DC jack type)/**

**⑤ DC IN 10 - 15 V (external power input) connector (XLR type 4-pin, male)**

Inputs the 10 to 15 V DC external power.

#### **Notes**

- An external battery other than BP-90 type battery cannot be connected to **④ DC IN 10 - 15 V (DC jack type) connector** because the polarity of the DC jack is different.
- Do not connect external batteries to both **④ DC IN 10 - 15 V connector (DC jack type)** and **⑤ DC IN 10 - 15 V connector (XLR type 4-pin)** at the same time. Be sure to connect the external battery to either one.

**⑥ STEREO/MONO (stereo/mono select) switch**

Changes signals to be output from all of the output connectors to either stereo or mono.

# Connections

## Note

Before making connections, be sure to turn the power of any peripheral equipment off.

## Basic Connection

An example of a basic connection where one DMX-P01 is used is as follows.

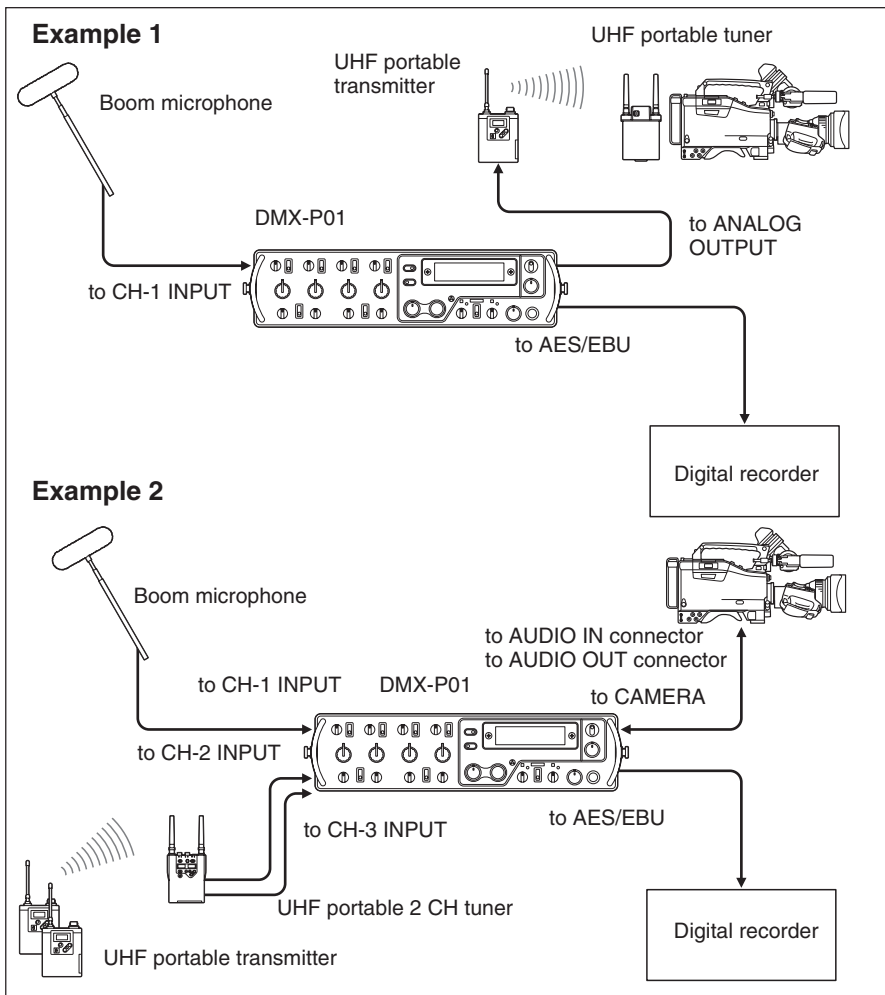

## Cascade Connection

An example of a cascade connection is as follows.

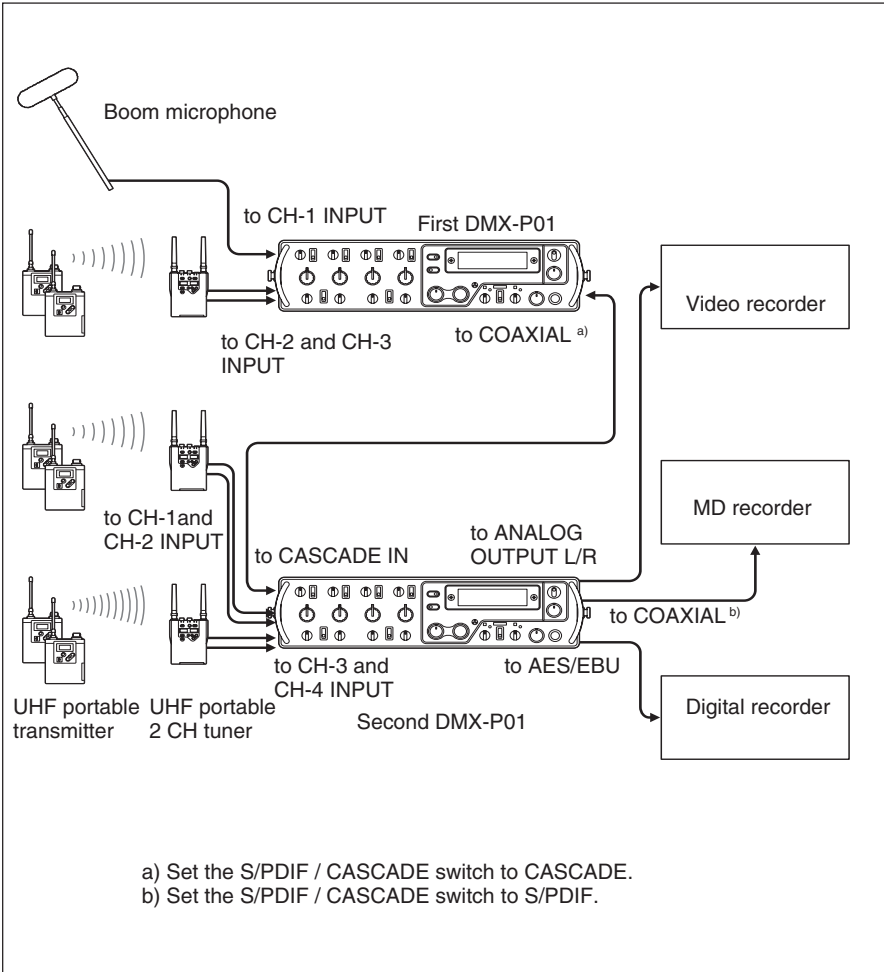

# Display in the Display Mode

The display mode, when the FUNCTION switch is set to DISPLAY, allows you to display all kinds of meters, the unit operating status and so on. In day-to-day operation, use the unit in the display mode. In display mode, four kinds of screen display are available. Select a desired screen display as follows.

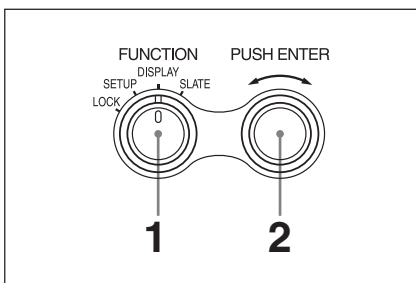

- 1** Set the FUNCTION switch to DISPLAY.
- 2** Display the desired screen display by turning the ADJUST knob.  
*For detailed information on the display mode, see the following "About the display mode."*

## About the display mode

There are four kinds of screen display, as follows.

### Full size level meter

Displays only the signal level. This mode is suitable when you want to monitor the signal level.

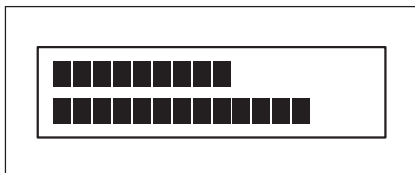

### Multi meter

Displays the accumulating time, level meter, and battery indicator. This is the default setting.

### When you use the internal battery:

You can confirm the amount of battery power remaining.



### When you use an external battery:

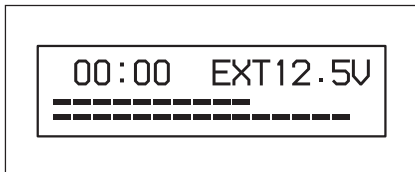

*For detailed information on the battery indicator, see "Battery life" on page 40.*

### Input level meter

Displays the pre-fader level of the input signal of each input connector. This display allows you to confirm whether or not the signal is input correctly.

### Input level meter for channels 1 and 2:

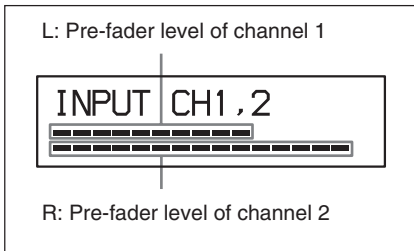

### Input level meter for channels 3 and 4:

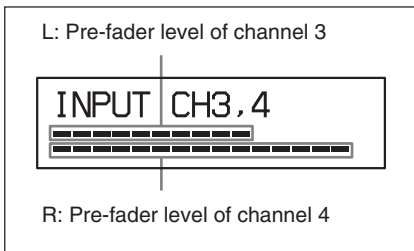

### Level meter display when the slate signal is output:

When the SLATE switch is set to MIC, the meter displays  $\infty$  while voice is being output from the slate microphone.

When the SLATE switch is set to 1 kHz, the meter displays the pre-fader level even though the 1-kHz reference signal is being output.

### Information

Displays the synchronization status and the sampling frequency.

LOCK: Appears when the unit is synchronized with the input signal from the CASCADE IN connector on the left panel.

UNLOCK: Appears when the unit is synchronized with the internal clock signal.

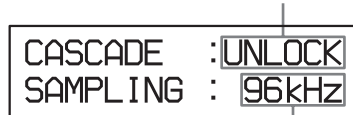

Displays the current sampling frequency.

### About the level meter display

You can change the type of level meter to be displayed on the LCD to another without replacing the entire meter. Six types, VU, PPM1, PPM2, PPM3, PPM4 and dBFS, are available. The dBFS display is selected at the default setting.

*For detailed information, see “11. METER SELECT Sub-Menu” on page 32.*

When you change the level meter type using the METER SELECT sub-menu, you should change the meter scale sheet (supplied).

*For detailed information on how to replace the meter scale sheet, see “Replacing a Meter Scale Sheet” on page 41.*

# Settings from the Setup Menu

## Setup Menu Structure

You can set all sorts of parameters using the setup menu organized in the following 13 sub-menus.

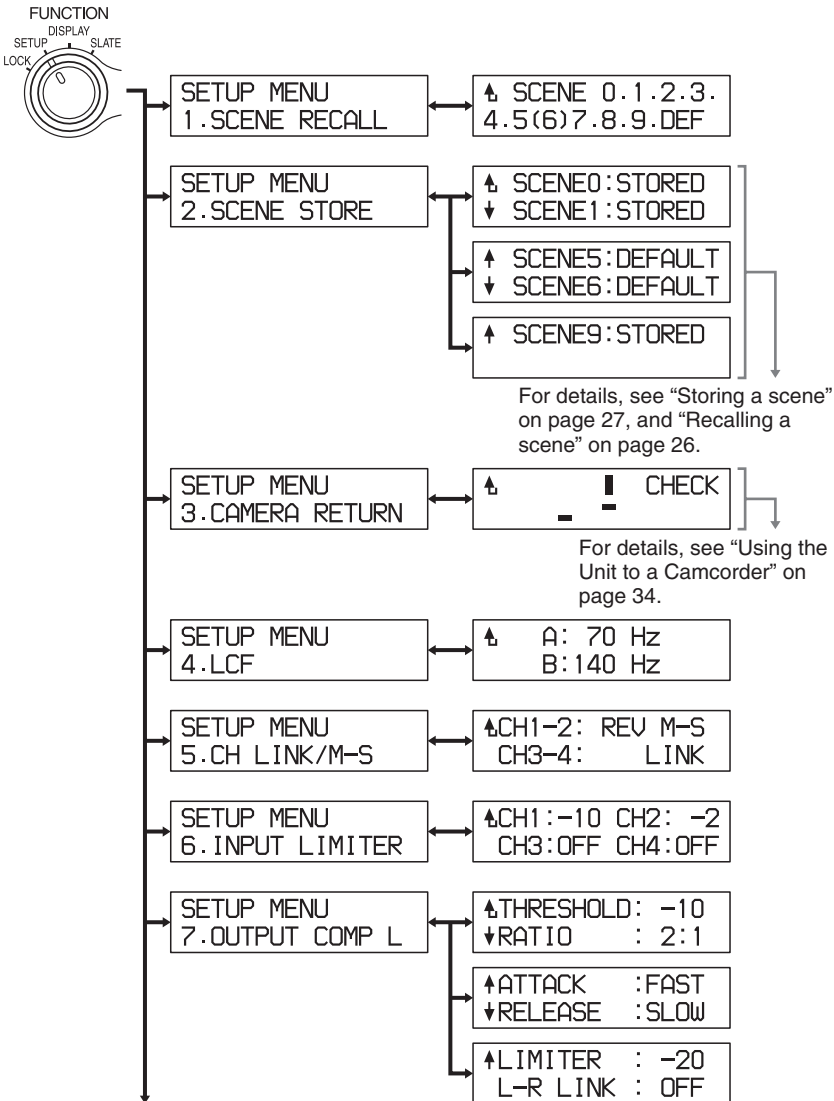

to the next page

from the previous page

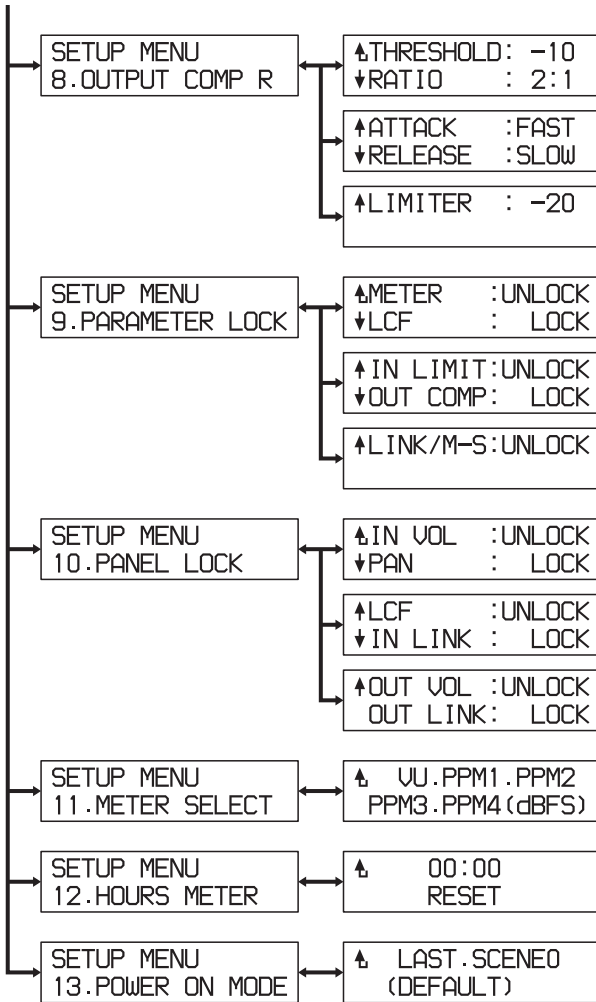

# Settings from the Setup Menu

## Basic Menu Operation

This section describes basic operating procedures for using a menu, taking the 9. PARAMETER LOCK sub-menu as an example.

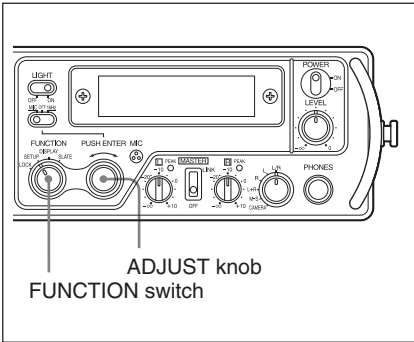

**1** Set the FUNCTION switch to SETUP.  
The sub-menu page of the SETUP menu that was used when the last menu operation was performed appears.

**2** Turn the ADJUST knob until the desired sub-menu page appears.  
In this case, turn the ADJUST knob until the ninth sub-menu, 9. PARAMETER LOCK sub-menu, appears.

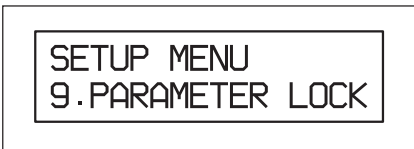

**3** Press the ADJUST knob to access the appropriate sub-menu.  
The unit displays the setting sub-menu to be used to make the settings.  
The return mark blinks.

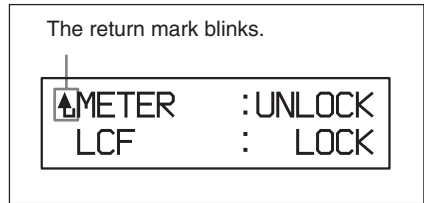

**4** Turn the ADJUST knob to the right.  
The unit allows you to select the item to be set.  
The return mark disappears from the LCD and the cursor moves to the first of the item that can be set.  
The first item, METER in this example, blinks.  
When the corresponding sub-menu has multiple items, such sub-menus are displayed as follows.

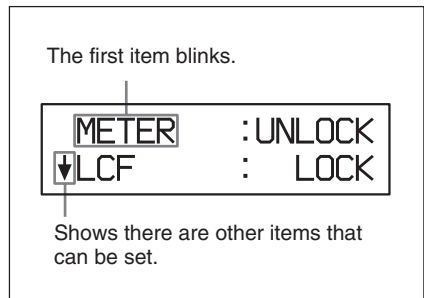

The first item blinks.

Shows there are other items that can be set.

When there are multiple items, go to step 5.  
When there is only one item, go to step 7.



When you want to perform an operation such as a reset (12. HOURS METER sub-menu), or a check of an item (3. CAMERA RETURN sub-menu) on the appropriate sub-menu, go to step 7.

- 5 Turn the ADJUST knob until the desired item blinks. Turning it to the right results in the cursor moving to the next item, and turning it to the left results in the cursor moving to the previous item.
- 6 Press the ADJUST knob. The cursor moves to the selection, or the set value of the selected item, and the selection or set value blinks.

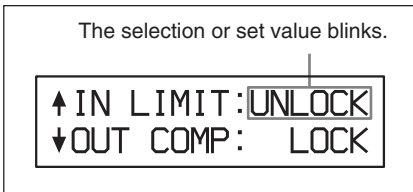

- 7 Turn the ADJUST knob to the right or left until the blinking cursor moves to the desired selection or the desired set value appears.  
**To reset on the 12. HOURS METER sub-menu or to check an item on the 3. CAMERA RETURN sub-menu:**  
Turning the ADJUST knob to the right results in RESET or CHECK blinking.

**To select the setting:**

Turn the ADJUST knob to the right or left, and the subsequent selection blinks.

**To increase or decrease the set value:**

Turning the ADJUST knob to the right or left increases or decreases the set value step by step.

**While adjusting the value:**

The unit operates using the value which is currently being adjusted. You can select the appropriate value while monitoring the response of the unit to the value as it is adjusted.

- 8 Press the ADJUST knob to execute the change. The change is carried out, and the setting is made. The cursor moves to the setting item and blinks. When there are multiple setting items to be set, perform the remaining settings by repeating steps 5 to 8. On the 12. HOURS METER sub-menu or on the 3. CAMERA RETURN sub-menu, resetting or checking is started by pressing the ADJUST knob.

**Note**

If you turn the power off without executing the change while performing operations in step 7, the settings or changes performed in step 7 are not stored. Be sure to execute the change in step 8 first, and then turn the power off.

# Settings from the Setup Menu

## To move to another sub-menu

- 1 When the cursor blinks beside the setting item just set, turn the ADJUST knob to the left until the return mark to the left of the top setting item appears and blinks.
- 2 Press the ADJUST knob. The sub-menu appears.
- 3 Turn the ADJUST knob to the left or right until the desired sub-menu appears, and then press the ADJUST knob.

## When you cannot enter the setting mode from the sub-menu

That sub-menu has been locked to prevent misoperation using 9. PARAMETER LOCK sub-menu. To perform settings on that sub-menu, unlock it using the 9. PARAMETER LOCK sub-menu.

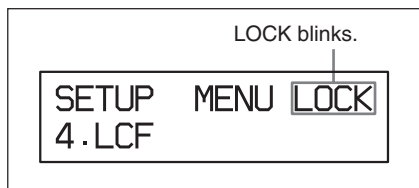

For details, see “9. PARAMETER LOCK Sub-Menu” on page 31.

## 1. SCENE RECALL Sub-Menu

### Recalling a scene

- 1 Turn the ADJUST knob until the 1. SCENE RECALL sub-menu appears, and then press the ADJUST knob.

▲ SCENE 0.1.2.3.  
4.5(6)7.8.9.DEF

The scene currently recalled is enclosed in parentheses.

### Note

If parameters included in the currently recalled scene are changed using a sub-menu, the parentheses disappear from the currently recalled scene indicator.

- 2 Turn the ADJUST knob until the scene number to be recalled blinks. Turning the ADJUST knob to the right changes the scene number in the following sequences: SCENE 0 → SCENE 1 → SCENE 2 .....SCENE 8 → SCENE 9 → DEF. Turning the ADJUST knob to the left changes the scene number in the reverse order.
- 3 Press the ADJUST knob. The scene selected in step 2 is recalled. This recalled scene number is enclosed in parentheses.

## 2. SCENE STORE Sub-Menu

This sub-menu allows you to store ten different parameter settings as a scene file from scenes nos. 0 to 9. Recalling the desired scene changes the unit to the desired setup immediately.

### Parameters stored in a scene file

Parameters set on sub-menus 4 to 11.

#### Note

For settings on the 10. PANEL LOCK sub-menu, only the locked switches and controls are stored. To actually lock those switches and controls, you should set the FUNCTION switch to the LOCK position.

### Storing a scene

- 1 Turn the ADJUST knob until the 2. SCENE STORE sub-menu appears, and then press the ADJUST knob.

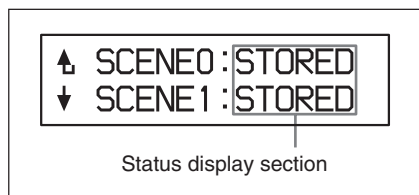

- 2 Turn the ADJUST knob until the desired scene number blinks. Turning the ADJUST knob to the right changes the scene number in the following sequences: SCENE 0 → SCENE 1 → SCENE 2 .....SCENE 8 → SCENE 9.

Turning the ADJUST knob to the left changes the scene number in the reverse order.

The status display section shows the status of each scene.

Display	Status
DEFAULT	The corresponding scene file is not used (parameters are default settings).
STORED	The default settings are overwritten (parameters other than the defaults are stored).

- 3 Press the ADJUST knob. The cursor moves to the status display section and CANCEL appears there.
- 4 Turn the ADJUST knob to the right to display WRITE. Turning the ADJUST knob to the right changes the status display section in the following sequence: CANCEL → WRITE → ERASE.  
**To cancel the storing operation and return the cursor to the scene number selection area:** Display CANCEL.  
**To reset the parameters to the default settings:** Display ERASE.
- 5 Press the ADJUST knob to execute the change. Parameters currently set are stored as a scene with the number selected in step 2.

## Settings from the Setup Menu

### 3. CAMERA RETURN Sub-Menu

This sub-menu allows you to check whether or not signal transmission and reception are correctly performed between the unit and a camcorder by transmitting a 1-kHz reference signal from all of output connectors of the unit.

By comparing the 1-kHz reference signal sent from the unit with the signal returned from the camcorder, an error is detected. You can confirm the connection status and adjust the output level and recording according to the error detected.

*For detailed information, see “Using the Unit to a Camcorder” on page 34.*

### 4. LCF Sub-Menu

This menu allows you to set two kinds of frequencies for the input low-cut filter as entries A and B.

You can change either A or B using the LCF switch on the front panel.

#### 4. LCF sub-menu

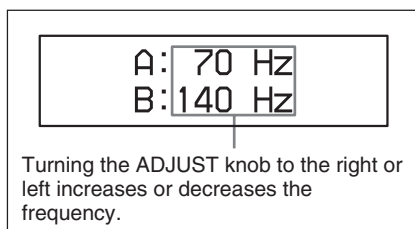

Turning the ADJUST knob to the right or left increases or decreases the frequency.

#### Default frequency for the low cut filter

A: 70 Hz

B: 140 Hz

#### Available frequencies

##### At the 48-kHz sampling frequency:

50, 70, 100, 120, 140, 160, 180, 200, 220, 240, 260, 280, 320, 360 and 400

##### At the 96-kHz sampling frequency:

70, 100, 120, 140, 160, 180, 200, 220, 240, 260, 280, 320, 360 and 400

#### Note

At the 96-kHz sampling frequency, 50 Hz cannot be selected.

If the 50 Hz frequency is selected at 48-kHz sampling frequency and the sampling frequency is switched to 96 kHz, the setting of 50 Hz is changed to 70 Hz. When the sampling frequency is switched to 48 kHz again, the setting of 50 Hz is restored.

## 5. CH LINK/M-S Sub-Menu

This menu allows you select whether input channels 1 and 2 or channels 3 and 4 are set to LINK mode or M-S mode independently.

### 5. CH LINK/M-S sub-menu

Turning the ADJUST knob to the right changes the setting item in the following sequence: CH1-2 → CH3-4.



Turning the ADJUST knob to the right changes the selection in the following sequence: LINK → M-S → REV M-S.

### Default setting: LINK

Selection	Function
LINK	Channels 1 and 2 or channels 3 and 4 are set to link mode and linked as stereo. Switches and controls of channel 1 or channel 3 are activated and those of channel 2 and channel 4 are disabled.
M-S	Selects when the MS microphone is used. Channels 1 and 2 or channels 3 and 4 are set to M-S mode. The input level control of channel 1 and channel 3 acts as the input level control of those channels and the input level control of channels 2 and 4 acts as the phase adjust knob.
REV M-S	Used when the MS microphone is placed upside down. In this mode, even if the MS microphone is placed upside down, the right and left signals are not reversed.

## 6. INPUT LIMITER Sub-Menu

This sub-menu allows you to set the threshold level of the limiter for each channel.

### 6. INPUT LIMITER sub-menu

Turning the ADJUST knob to the right changes the setting item changes in the following sequence: CH1 → CH2 → CH3 → CH4.



Turning the ADJUST knob to the right or left increases or decreases the set value between OFF, 0 and -20 dBFS in units of 2 dB.

### Default threshold level

CH1 to CH4: OFF

### Display of the threshold level

When the dBFS meter is selected on the 11. METER SELECT sub menu, the threshold level is displayed in the unit of dBFS.

**The adjustable range:** Between OFF, 0 and -20.

When the meter other than the dBFS meter is selected, the threshold level is displayed in the unit of dB.

**The adjustable range:** Between OFF, +20 and 0.

# Settings from the Setup Menu

## 7. OUTPUT COMP L Sub-Menu/8. OUTPUT COMP R Sub-Menu

These sub-menus allow you to perform settings for compressors and limiters of the Left and Right channels.

### 7. OUTPUT COMP L sub-menu/ 8. OUTPUT COMP R sub-menu

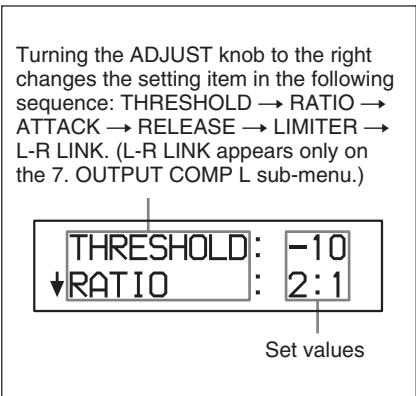

Item	Set value	Default
THRESHOLD	OFF, -10 to -40 dBFS (+10 to -20 dB), adjustable in 2 dB step.	OFF
RATIO	2:1, 4:1, 6:1, 10:1	2:1
ATTACK	FAST (0.5ms), MID (10ms), SLOW (100ms)	MID (10ms)
RELEASE	FAST (0.1sec), MID (1sec), SLOW (2sec)	MID (1sec)
LIMITER	OFF, 0 to -20 dBFS (+20 to 0 dB), adjustable in 2 dB step.	OFF
L-R LINK <sup>a)</sup>	Turns LINK mode on or off.	OFF

- a) This item is displayed only on the OUTPUT COMP L sub-menu. Setting this item to ON activates the stereo link function and prevents any unnatural fluctuation of the audio.

### Display of the threshold level and limiter

When the dBFS meter is selected on the 11. METER SELECT sub menu, the threshold level and the limiter are displayed in the unit of dBFS.

**The adjustable range of the threshold level:** Between OFF, -10 and -40.

**The adjustable range of the limiter:** Between OFF, 0 and -20.

When the meter other than the dBFS meter is selected, the threshold level and the limiter displayed in the unit of dB.

**The adjustable range of the threshold level:** Between OFF, +10 and -20.

**The adjustable range of the limiter:** Between OFF, +20 and 0.

**Note**

When L-R LINK is set to ON, you cannot work on the 8. OUTPUT COMP R sub-menu. If you select the 8. OUTPUT COMP R sub-menu and press the ADJUST knob, the following message appears.



**9. PARAMETER LOCK Sub-Menu**

This sub-menu allows you to lock parameters set on the following sub-menus.

- 4. LCF
- 5. CH LINK/M-S
- 6. INPUT LIMITER
- 7. OUTPUT COMP L
- 8. OUTPUT COMP R
- 11. METER SELECT

You can select the lock function on each sub-menu.

**9. PARAMETER LOCK sub-menu**

Turning the ADJUST knob to the right changes the setting item in the following sequence: METER → LCF → IN LIMIT → OUT COMP (including L and R) → LINK/M-S.



Turning the ADJUST knob to the left changes the selection changes in the following sequence: UNLOCK → LOCK.

**Default setting: UNLOCK**

**For locked sub-menus**

LOCK is displayed (blinking) at the top right of the sub-menu. On this sub-menu you cannot change to the setting mode even if you press the ADJUST knob.

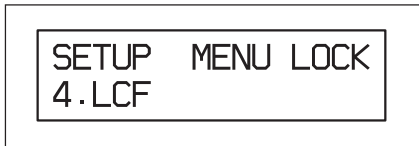

# Settings from the Setup Menu

## 10. PANEL LOCK Sub-Menu

When the FUNCTION switch is set to LOCK, all of or some of the switches and controls on the front panel are locked and you cannot operate them. This sub-menu allows you to decide which switches and controls should be locked, from among the input level control, PAN control, LCF switch, L/R MASTER output level control, LINK/M-S switch, and MASTER LINK control.

### 10. PANEL LOCK sub-menu

Turning the ADJUST knob to the right changes the setting item in the following sequence: IN VOL → PAN → LCF → IN LINK → OUT VOL → OUT LINK.

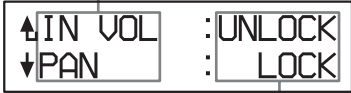

Turning the ADJUST knob to the right changes the selection in the following sequence: LOCK → UNLOCK.

**Default setting: LOCK**

## 11. METER SELECT Sub-Menu

This sub-menu allows you to select the level meter to be displayed on the LCD from among 6 types of meter, VU, PPM1, PPM2, PPM3, PPM4 and dBFS.

The dBFS meter is the default. When you change the type of meter displayed using this sub-menu, you should replace the meter scale sheet with the one corresponding to the new meter.

*For detailed information on the supplied meter scale sheets, see “Replacing a Meter Scale Sheet” on page 41.*

### 11. METER SELECT sub-menu

Turning the ADJUST knob to the right changes the selection in the following sequence: VU → PPM1 → PPM2 → PPM3 → PPM4 → dBFS.



The type of the meter currently being displayed is surrounded by parenthesis.

#### Note

The following table shows the relationship between the meter displayed on the LCD and the meter type.



Menu selection	Meter
VU	VU meter
PPM1	BBC-type meter
PPM2	DIN-type meter
PPM3	NORDIC-type meter
PPM4	IEC-type 1-type meter
dBFS	dBFS meter

**Default setting: dBFS**

## 12. HOURS METER Sub-Menu

This sub-menu allows you to reset the accumulating time.

### 12. HOURS METER sub-menu

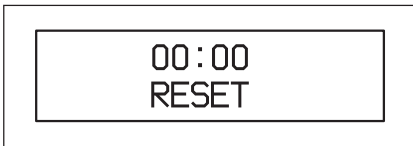

When the time is reset, 00:00 appears in the upper row.

## 13. POWER ON MODE Sub-Menu

This sub-menu allows you to select with which settings the unit starts when the power is turned on.

### 13. POWER ON MODE sub-menu

Turning the ADJUST knob to the right changes the setting item in the following sequence: LAST → SCENE 0 → DEFAULT.

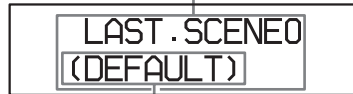

The selected mode is enclosed in parenthesis.

### Default setting: LAST

The available power on modes are as follows.

Selection	Status at power on
LAST	Same settings as the last time the unit was used.
SCENE 0	Settings stored as Scene 0.
DEFAULT	Default settings

# Using the Unit to a Camcorder

This section describes how to connect the unit to a camcorder and how to check the connection status.

## Connecting a Camcorder

Connect the camcorder to the CAMERA connector of the unit using the 10-line multi cable with a 12-pin multi connector supplied with the unit. You can send signals from the unit and receive return signals from the

camcorder only if you use a multi cable.

*For detailed information on the pin assignment of the CAMERA connector of the unit, see "Pin Assignments of Connectors" on page 44.*

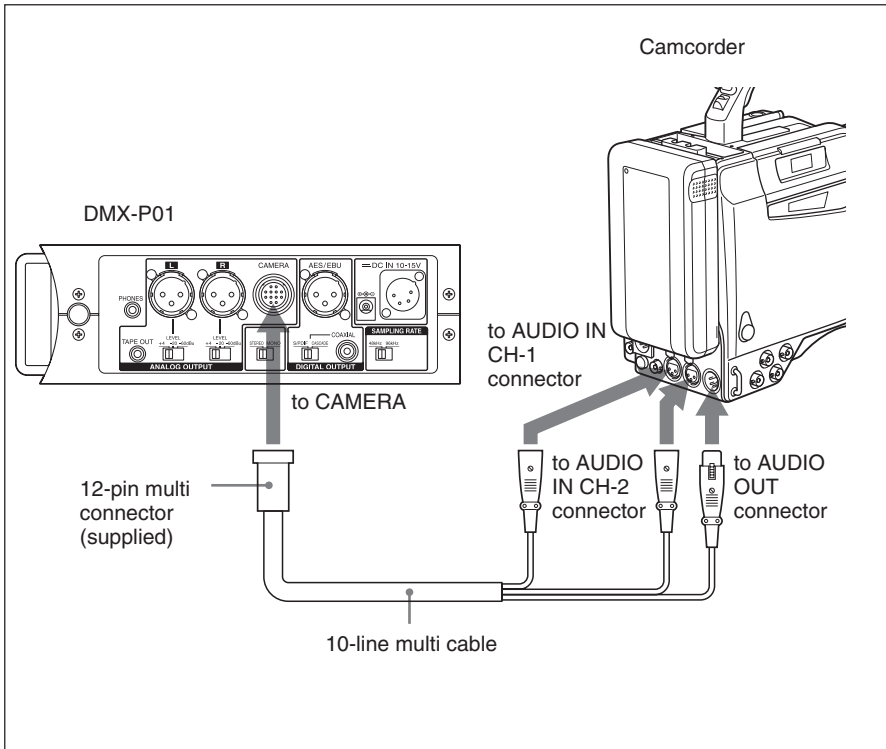

## Checking the Status of a Connection

The 3. CAMERA RETURN sub-menu allows you to check for misconnections of lines or other problems between the unit and the camcorder. This function can prevent trouble.

To confirm the status of a connection, proceed as follows.

- 1 Turn on the power of the unit and the camcorder.
- 2 Match the reference level of the unit and the camcorder.  
Set the LEVEL switch on the right panel of the unit and the input level select switch on the camcorder to the same value.  
**When connecting with a +4 dBu reference output level:**  
Set the LEVEL switch of the unit to +4 and the input level select switch of the camcorder to LINE.  
**When connecting with a -60 dBu reference level:**  
Set the LEVEL switch of the unit to -60 and the input level select switch of the camcorder to MIC.  
*For detailed information on the switches of the camcorder, refer to the operations manual supplied with the camcorder.*
- 3 Send a 1-kHz reference signal using the SLATE function of the unit, and adjust the output level of the unit to the reference value using the L/R MASTER volume control.

The following table shows the reference position of each meter.

Output meter	Reference position
VU	0
PPM1	4
PPM2	0
PPM3	0
PPM4	0
dBFS	-20

*For detailed information on how to output the reference signal, see "To output the voice from the microphone or a 1-kHz reference signal" on page 10.*

- 4 Adjust the REC level of the camcorder.  
Adjust the level control of the camcorder so that the level meter of a camcorder points to 20. The adjustment required for checking the status of a connection between the unit and the camcorder has been completed.  
Now, perform a final check of the connection status using the 3. CAMERA RETURN sub-menu.
- 5 Display the 3. CAMERA RETURN sub-menu, and then push the ADJUST knob. The CHECK window appears.

*(continued)*

# Using the Unit to a Camcorder

**6** Turn the ADJUST knob to the right so that CHECK blinks on the sub-menu, and then press the ADJUST knob.

The test signal is output and the unit starts checking the status of the connection.

When the unit and the camcorder are connected correctly, the following window appears.



When the L/R MASTER level control of the unit or the REC level of the camcorder is not correctly adjusted, the following window appears.

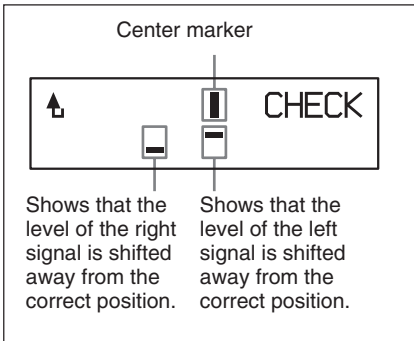

**When the marker is located on the left side of the center marker:**

The level of the return signal from the camcorder is lower.

**When the marker is located on the right side of the center marker:**

The level of the return signal from the camcorder is higher.

In either case, the L/R MASTER level control of the unit or the REC level of the camcorder is not correctly adjusted.

Readjust the level so that the marker is located at the center, repeating steps 2 and 3, as necessary.

A message stating the result of the check also appears.

*For detailed information on messages, see the following "Messages stating the results of check", on page 37.*

### Note

This adjustment function of the return signal level is effective when a camcorder with a balanced output of 0 dBu is used.

**7** Push the ADJUST menu. The unit stops outputting the test signal and completes the check of the status of the connection.

**To return to the setup menu**

Turn the ADJUST knob to the left until the return mark blinks, and then press the ADJUST knob.

---

## Messages stating the results of check

Message	Meaning
SIGNAL OK	Both left and right signals are connected correctly.
L-R REVERSE	The connection of the left and right signals are reversed.
L-R NO SIGNAL	Neither the left nor right signal is connected. Or the connection is broken.
Lch NO SIGNAL	The left signal is not connected or the connection is broken.
Rch NO SIGNAL	The right signal is not connected or the connection is broken.
Lch LEAK	The sound is leaking to the left channel, or abnormal sound exists in the left channel.
Rch LEAK	The sound is leaking to the right channel, or abnormal sound exists in the right channel.

# Miscellaneous

## Preparing a Power Supply

The unit can be powered in the following two ways:

- **Internal batteries**

Eight LR6 (size AA) alkaline batteries can be accommodated in the battery compartment.

- **External battery**

A lithium ion battery or nickel metal hydride battery which is connected to the DC IN 10 - 15 V connector on the right panel. The unit is equipped with two types of DC IN 10 - 15 V connector, an XLR 4-pin and a DC jack type connector. Use either one depending on the external battery you are using.

### Notes

- Do not connect external batteries to both the 4-pin of the XLR type connector and the DC jack type connector at the same time. Be sure to connect the external battery to either one. Connecting external batteries to both connectors may cause the deterioration of the external batteries.
- Do not connect the external battery other than the BP-90 type battery to the DC jack type connector, because the polarity of the DC jack is different.

## When both internal batteries and an external battery are used

When the power of the unit is turned on, the power is supplied from the external battery. Since the unit can be

powered by an external battery while preserving the life of the internal batteries, the power supply is switched from internal batteries if the DC cord is disconnected accidentally or the external battery is shut down suddenly.

## Inserting the Batteries in the Battery Compartment

- 1 Pull the battery compartment toward you by pressing the lock levers.

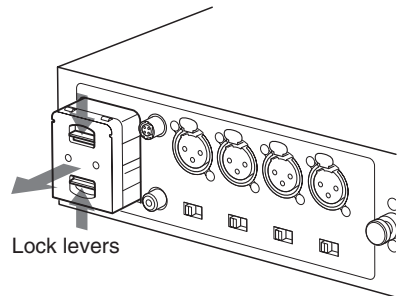

- 2 Open the cover of the battery compartment by loosening the screw as illustrated.

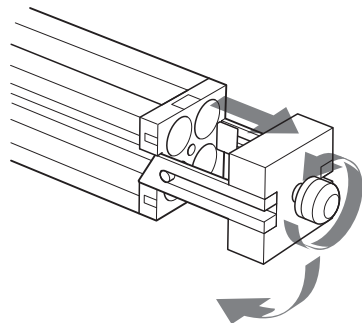

- 3** Align eight new LR6 (size AA) alkaline batteries with the polarity markings and insert them into the battery compartment.

Insert the batteries by aligning the polarity according to the markings on the battery compartment.

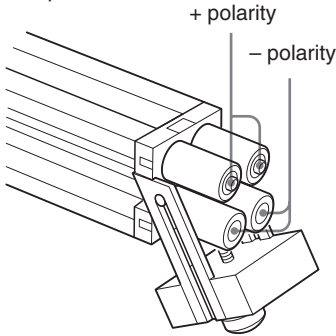

- 4** Close the cover of the battery compartment and tighten the screw.

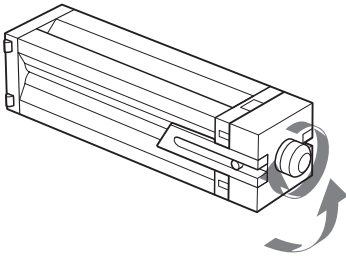

- 5** Reinsert the battery compartment as it was.

Insert the battery compartment with the rounded corners facing upward.

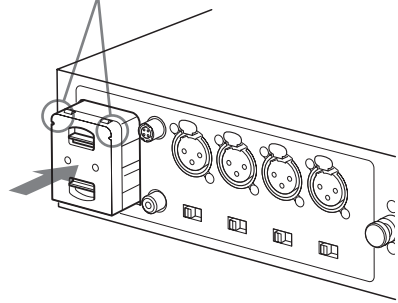

#### Notes

- When you are not using the unit for a long period of time, remove the batteries to avoid leakage.
- If the batteries do leak, clean all the leakage from the battery compartment and the components. Replace the batteries with new ones.
- Always replace the eight batteries all at the same time. Do not use different types of batteries or old and new ones together.

#### About the spare battery compartment

A spare battery compartment is supplied with the unit. If you insert eight new LR6 (size AA) alkaline batteries in this spare battery compartment beforehand, you can replace the regular battery compartment with the spare battery compartment quickly and easily when the internal batteries run low.

# Miscellaneous

## Battery life

When the multi meter mode of the LCD is selected, the battery condition is shown on the LCD.

### To check the power remaining in the internal batteries

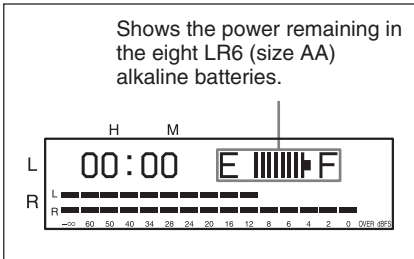

When the amount of power remaining in the batteries is low, the battery indication on the LCD starts flashing. Replace the batteries with new ones, or use the external battery. *For details, see “When the internal batteries run low” below.*

### To check the power remaining in the external battery

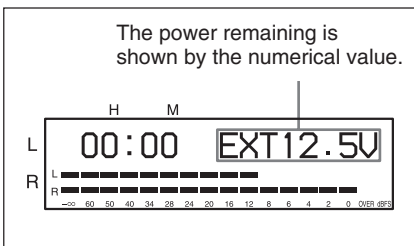

The power voltage input to the DC IN 10 - 15 V connector is shown on the LCD.

The battery designed for a camcorder, such as a lithium ion battery, is shut down around 10 V. The numerical value starts flashing when the battery power decreases to less than 10 V. Replace the external battery or use the internal batteries.

*For details, see “When the external battery runs low” below. When the external battery is equipped with a battery indicator, check this battery indicator, too.*

### When the external battery runs low

When internal batteries are loaded in the battery compartment, disconnect the DC cable of the external battery. The power is automatically supplied from the internal batteries.

### When the internal batteries run low

Before removing the battery pack, connect the DC cable of the external battery to the DC IN 10 - 15 V connector with the power switch of the unit set to on to switch to the external battery.



## Replacing a Meter Scale Sheet

When you change the meter displayed using the 11. METER SELECT sub-menu, you have to replace the meter scale sheet with the corresponding one.

As the factory setting, the dBFS meter is selected and the meter scale sheet for the dBFS meter is attached to the unit.

To change a meter scale sheet, proceed as follows.

- 1 Loosen the screws located at both sides of the acrylic panel of the LCD, and push either side of the panel. The other side of the panel pops up.

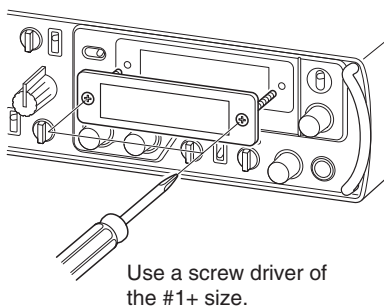

- 2 Remove the acrylic panel.

- 3 Remove the meter scale sheet from the inside of the acrylic panel, and insert the corresponding meter scale sheet.

The type of meter is written at the right top of the meter scale sheet.

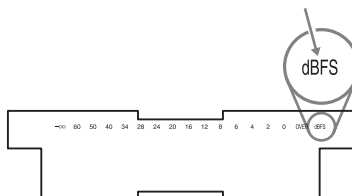

- 4 Replace the acrylic panel, and tighten the screws.

### Note

After the meter scale sheet has been attached, check that the meter scale is not crooked.

## Troubleshooting

If a problem appears, check the following trouble shooting guide first, and perform whatever action is

necessary to solve the problem. If the problem persists, turn the unit off and consult your Sony dealer.

Symptom	Possible causes	Remedies
The power does not turn on.	Batteries are inserted with the + and – polarities reversed.	Insert the batteries with the correct polarities. (page 39)
	The batteries run low.	Replace the eight internal batteries with new ones. (page 38)
	The screws of the cover of the battery compartment are loose.	Tighten the screws. (page 39)
The batteries run low quickly.	The batteries run low.	Replace the eight internal batteries with new ones. (page 38)
	You are using manganese batteries.	Use alkaline batteries. (page 38)
The volume does not increase even through the input level control of channels 2 or 4 is increased.	The LINK/M-S switch is set to the LINK/M-S side.	Set the LINK/M-S switch is set to OFF. When the LINK/M-S switch is set to the LINK/M-S side, channels 1 and 2 and channels 3 and 4 are linked. In this case, the controls of even channels do not activate. (page 9)
Power is not supplied to the DC OUT connector.	The unit is running on the internal batteries.	Use the external battery. The external battery output function activates only when the unit works on the external battery. (page 38)
The indication of the level meter and the meter scale do not match.	The meter scale sheet attached and the meter display selected using the METER SELECT sub-menu are different.	Replace the meter scale sheet with one that matches the meter you are using. (pages 32 and 41)
Each time the power is turned on, the parameters are reset to the default settings.	The POWER ON MODE is set to DEFAULT on the POWER ON MODE sub-menu.	The power-on setting can be changed on the POWER ON MODE sub-menu. You can select the mode from among LAST, DEFAULT and SCENE 0. (page 33)

Symptom	Possible causes	Remedies
An impression of stereo sound cannot be obtained. even when an MS microphone is used.	The S side of the MS microphone is connected to channel 1 or channel 3, and the M side is connected to channel 2 or channel 4.	Connect the M side to channel 1 or 3 and the S side to channel 2 or 4.
	LINK/M-S is set to LINK on the LINK/M-S sub-menu.	Change the LINK/M-S setting to M-S on the LINK/M-S sub menu.
Sound is not output from the R channels of the headphones.	A monaural earphone is connected to the other PHONES connector.	Use stereo headphones or earphones.
The sampling rate cannot be switched.	The unit was not restarted when the SAMPLING RATE switch setting was changed.	Restart the unit after you change the sampling rate. The setting of the SAMPLING RATE switch is switched only when the unit is restarted. (page16)
The MASTER volume does not activate to adjust the level of the signal output from the COAXIAL connector.	The S/PDIF/CASCADE switch is set to CASCADE.	Set the switch to S/PDIF. The CASCADE function is used only when two DMX-P01s are connected in cascade. In this case, the MASTER volume control does not activate. (page 16)

# Miscellaneous

## Pin Assignments of Connectors

### INPUT connector

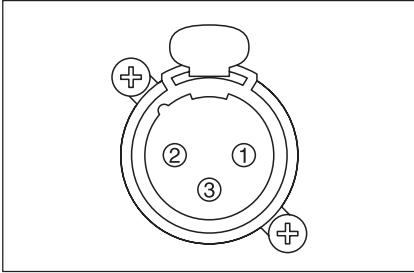

XLR-3-31 (female) equivalent

Pin No.	Signal	Remarks
1	GND	Ground of the audio signal input
2	HOT	HOT of the audio signal input
3	COLD	COLD of the audio signal input

### ANALOG OUTPUT connector

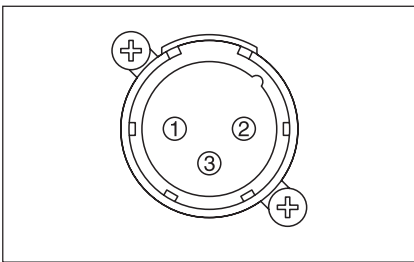

XLR-3-32 (male) equivalent

Pin No.	Signal	Remarks
1	GND	Ground of the audio signal output
2	HOT	HOT of the audio signal output
3	COLD	COLD of the audio signal output

### CAMERA connector

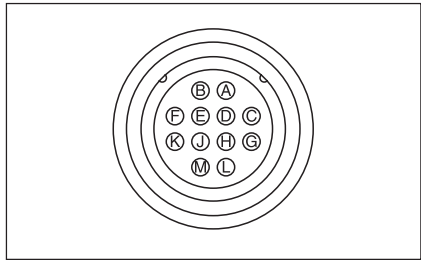

12-pin (female)

Pin No.	Signal	Remarks
A	L HOT	HOT of the left output of the master audio signal
B	L COLD	COLD of the left output of the master audio signal
C	R HOT	HOT of the right output of the master audio signal
D	R COLD	COLD of the right output of the master audio signal
E	L HOT	HOT of the left input of the camera return signal
F	L COLD	COLD of the left input of the camera return signal
G	R HOT	HOT of the right input of the camera return signal
H	R COLD	COLD of the right input of the camera return signal
J	GND	Ground of the output of the master audio signal
K	GND	Ground of the input of the master audio signal
L	NC	Not connected
M	NC	Not connected

### DC IN 10 -15 V connector

XLR-4-32 (male) equivalent

Input voltage range +10 to +15V

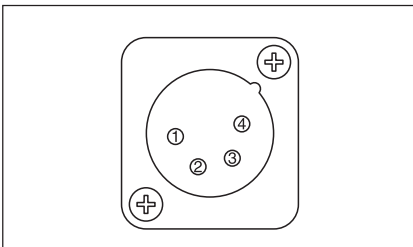

Pin No.	Signal	Remarks
1	GND	Ground of the DC input
2	NC	Not connected
3	NC	Not connected
4	DC INPUT	DC power input

### DC jack

Input voltage range +10 to +15V

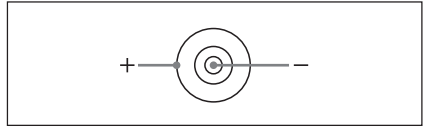

### DC OUT connector

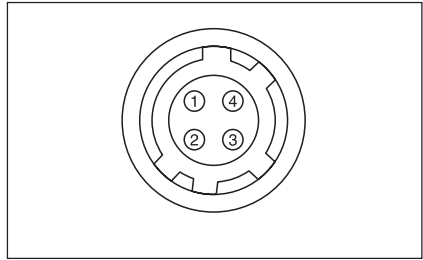

4-pin (female)

Output voltage range +10 to +15V

Pin No.	Signal	Remarks
1	GND	Ground of the DC output
2	NC	Not connected
3	NC	Not connected
4	DC OUTPUT	DC power output

# Specifications

## General

### Power requirements

10 - 15 V DC (at the external power supply from the DC IN 10 - 15 V connector)

### Maximum power consumption

1400 mA or less (at the external power supply from the DC IN 10 - 15 V connector)

### Operating temperature

0°C to 45°C  
(32°F to 113°F)

### Storage temperature

-20°C to 60°C  
(-4°F to 140°F)

### Continuous operation time

Approx. 5 hours  
at the following condition:  
Power supply; 8 LR6/  
AA-size Sony alkaline  
batteries  
Sampling frequency;  
48 kHz,  
Temperature; 25°C  
(77°F),  
LCD Light; off  
DC +48 V; off

Mass Approx. 2.2 kg (4 lb 14 oz)

### Dimensions

266 × 68 × 206 mm  
(10½ × 2¾ × 8⅛ inches)  
(w/h/d) (excluding  
projecting parts)

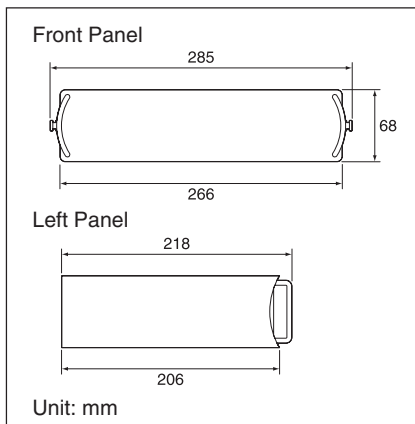

## Input/output

### INPUT (Analog)

XLR-3-31 (female)  
equivalent × 4  
Reference input level:  
-70 dBu to -30 dBu,  
2.2 kΩ (at the MIC  
setting)  
-30 dBu to +10 dBu,  
10 kΩ (at the LINE  
setting)  
Maximum input level:  
-50 dBu to -10 dBu,  
2.2 kΩ (at the MIC  
setting)  
-10 dBu to +30 dBu,  
10 kΩ (at the LINE  
setting)

### CASCADE INPUT (Digital)

Phono jack, 75 Ω

### ANALOG OUTPUT (Analog)

XLR-3-32 (male) × 2  
load impedance: 600 Ω or  
more  
Reference output level:  
+4/-20/-60 dBu  
Maximum output level:  
+24 dBu (at +4 dB output  
setting)

---

AES/EBU (Digital)  
XLR-3-32 (male)  
equivalent, 110  $\Omega$

S/PDIF / CASCADE (Digital)  
Phono jack, 75  $\Omega$

PHONES (Analog)  
Stereo phone jack  $\times$  1  
3.5 mm TRS jack  $\times$  1,  
load impedance:  
32  $\Omega$  or more,  
300 mW or more (at a  
32  $\Omega$  load)

TAPE OUT (Analog)  
3.5 mm TRS jack, load  
impedance: 10 k $\Omega$  or  
more,  
Reference output level:  
-10 dBu  
Maximum output level:  
+ 10 dBu

CAMERA  
12-PIN  
Reference input level:  
0 dBu  
Reference output level:  
+4/-20/-60 dBu

DC OUT  
4-pin (female), output  
voltage range:  
+10 to +15 V

DC IN 10 - 15 V  
XLR-4-32 (male)  
equivalent,  
input voltage range:  
+10 to +15 V  
DC jack, input voltage  
range: +10 to +15 V

---

## Audio characteristics

Frequency response  
20 Hz to 20 kHz, 0.5/-1 dB  
(at a 48-kHz sampling  
frequency)  
20 Hz to 40 kHz, 0.5/-3 dB  
(at a 96-kHz sampling  
frequency)

Noise level (E.I.N)  
-130 dBu or less  
(A-weighted, mic input,  
150  $\Omega$  terminated, typical)

T.H.D 0.05 % or less (at 1 kHz,  
+4 dBu)

Maximum output level  
+24 dBu, load impedance  
10 k $\Omega$

Crosstalk -90 dB or less (at 1 kHz)

---

## Supplied accessories

Meter scale sheet (5)  
Spare battery compartment (1)  
Feet (4)<sup>a)</sup>  
12-pin multi connector (1)  
Clamp filter (2)  
Band (2)  
Operating Instructions (1)  
CD-ROM (Operating Instructions pdf  
files) (1)

a) When you use the unit on a desk, it may slide around easily. To prevent it from moving, it is recommended that you attach the feet supplied to the bottom of the unit.

Design and specifications are subject to change without notice.

# Block Diagram

