

Part No. 312755-G Rev 00  
May 2006

4655 Great America Parkway  
Santa Clara, CA 95054

# **Installing the Breaker Interface Panel for the Ethernet Routing Switch 8010co Chassis**

**NORTEL**

## **Copyright © 2006 Nortel Networks. All Rights Reserved.**

The information in this document is subject to change without notice. The statements, configurations, technical data, and recommendations in this document are believed to be accurate and reliable, but are presented without express or implied warranty. Users must take full responsibility for their applications of any products specified in this document. The information in this document is proprietary to Nortel.

### **Trademarks**

\*Nortel, the Nortel logo, and the Globemark are trademarks of Nortel.

Adobe and Acrobat Reader are trademarks of Adobe Systems Incorporated.

### **Statement of conditions**

In the interest of improving internal design, operational function, and/or reliability, Nortel Inc. reserves the right to make changes to the products described in this document without notice.

Nortel Inc. does not assume any liability that may occur due to the use or application of the product(s) or circuit layout(s) described herein.

### **International regulatory statements of conformity**

This is to certify that the Nortel 8000 Series chassis and components installed within the chassis were evaluated to the international regulatory standards for electromagnetic compliance (EMC) and safety and were found to have met the requirements for the following international standards:

- EMC - Electromagnetic Emissions – CISPR 22, Class A
- EMC - Electromagnetic Immunity – CISPR 24
- Electrical Safety – IEC 60950, with CB member national deviations

Further, the equipment has been certified as compliant with the national standards as detailed below.

### **National electromagnetic compliance (EMC) statements of compliance**

#### **FCC statement (USA only)**

This equipment has been tested and found to comply with the limits for a Class A digital device, pursuant to Part 15 of the Federal Communications Commission (FCC) rules. These limits are designed to provide reasonable protection against harmful interference when the equipment is operated in a commercial environment. This equipment generates, uses, and can radiate radio frequency energy. If it is not installed and used in accordance with the instruction manual, it may cause harmful interference to radio communications. Operation of this equipment in a residential area is likely to cause harmful interference, in which case users will be required to take whatever measures may be necessary to correct the interference at their own expense.

#### **ICES statement (Canada only)**

##### **Canadian Department of Communications Radio Interference Regulations**

This digital apparatus (8000 Series chassis and installed components) does not exceed the Class A limits for radio-noise emissions from digital apparatus as set out in the Radio Interference Regulations of the Canadian Department of Communications.

---

## Règlement sur le brouillage radioélectrique du ministère des Communications

Cet appareil numérique (8000 Series chassis) respecte les limites de bruits radioélectriques visant les appareils numériques de classe A prescrites dans le Règlement sur le brouillage radioélectrique du ministère des Communications du Canada.

## CE marking statement (Europe only)

### EN 55 022 statements

This is to certify that the Nortel 8000 Series chassis and components installed within the chassis are shielded against the generation of radio interference in accordance with the application of Council Directive 89/336/EEC. Conformity is declared by the application of EN 55 022 Class A (CISPR 22).

**Warning:** This is a Class A product. In a domestic environment, this product may cause radio interference, in which case, the user may be required to take appropriate measures.

**Achtung:** Dieses ist ein Gerät der Funkstörgrenzwertklasse A. In Wohnbereichen können bei Betrieb dieses Gerätes Rundfunkstörungen auftreten, in welchen Fällen der Benutzer für entsprechende Gegenmaßnahmen verantwortlich ist.

**Attention:** Ceci est un produit de Classe A. Dans un environnement domestique, ce produit risque de créer des interférences radioélectriques, il appartiendra alors à l'utilisateur de prendre les mesures spécifiques appropriées.

### EN 55 024 statement

This is to certify that the Nortel 8000 Series chassis is shielded against the susceptibility to radio interference in accordance with the application of Council Directive 89/336/EEC. Conformity is declared by the application of EN 55 024 (CISPR 24).

## EC Declaration of Conformity

This product conforms to the provisions of the R&TTE Directive 1999/5/EC.

## VCCI statement (Japan/Nippon only)

This is a Class A product based on the standard of the Voluntary Control Council for Interference (VCCI) for information technology equipment. If this equipment is used in a domestic environment, radio disturbance may arise. When such trouble occurs, the user may be required to take corrective actions.

この装置は、情報処理装置等電波障害自主規制協議会（VCCI）の基準に基づくクラスA情報技術装置です。この装置を家庭環境で使用すると電波妨害を引き起こすことがあります。この場合には使用者が適切な対策を講ずるよう要求されることがあります。

---

## Denan statement (Japan/Nippon only)

---



### 警告

本製品を安全にご使用頂くため、以下のことにご注意ください。

- 接続ケーブル、電源コード、ACアダプタなどの部品は、必ず製品に同梱されております添付品または指定品をご使用ください。添付品・指定品以外の部品をご使用になると故障や動作不良、火災の原因となることがあります。
  - 同梱されております付属の電源コードを他の機器には使用しないでください。上記注意事項を守らないと、死亡や大怪我など人身事故の原因となることがあります。
- 

## National safety statements of compliance

### CE marking statement (Europe only)

#### EN 60 950 statement

This is to certify that the Nortel 8000 Series chassis and components installed within the chassis are in compliance with the requirements of EN 60 950 in accordance with the Low Voltage Directive. Additional national differences for all European Union countries have been evaluated for compliance. Some components installed within the 8000 Series chassis may use a nickel-metal hydride (NiMH) and/or lithium-ion battery. The NiMH and lithium-ion batteries are long-life batteries, and it is very possible that you will never need to replace them. However, should you need to replace them, refer to the individual component manual for directions on replacement and disposal of the battery

### Nortel Inc. software license agreement

This Software License Agreement (“License Agreement”) is between you, the end-user (“Customer”) and Nortel Corporation and its subsidiaries and affiliates (“Nortel”). PLEASE READ THE FOLLOWING CAREFULLY. YOU MUST ACCEPT THESE LICENSE TERMS IN ORDER TO DOWNLOAD AND/OR USE THE SOFTWARE. USE OF THE SOFTWARE CONSTITUTES YOUR ACCEPTANCE OF THIS LICENSE AGREEMENT. If you do not accept these terms and conditions, return the Software, unused and in the original shipping container, within 30 days of purchase to obtain a credit for the full purchase price.

“Software” is owned or licensed by Nortel, its parent or one of its subsidiaries or affiliates, and is copyrighted and licensed, not sold. Software consists of machine-readable instructions, its components, data, audio-visual content (such as images, text, recordings or pictures) and related licensed materials including all whole or partial copies. Nortel grants you a license to use the Software only in the country where you acquired the Software. You obtain no rights other than those granted to you under this License Agreement. You are responsible for the selection of the Software and for the installation of, use of, and results obtained from the Software.

**1. Licensed Use of Software.** Nortel grants Customer a nonexclusive license to use a copy of the Software on only one machine at any one time or to the extent of the activation or authorized usage level, whichever is applicable. To the extent Software is furnished for use with designated hardware or Customer furnished equipment (“CFE”), Customer is granted a nonexclusive license to use Software only on such hardware or CFE, as applicable. Software contains trade secrets and Customer agrees to treat Software as confidential information using the same care and discretion Customer uses with its own similar information that it does not wish to disclose, publish or disseminate. Customer will ensure that anyone who uses the Software does so only in compliance with the terms of this Agreement. Customer shall not a) use, copy, modify, transfer or distribute the Software except as expressly authorized; b) reverse assemble, reverse compile,

---

reverse engineer or otherwise translate the Software; c) create derivative works or modifications unless expressly authorized; or d) sublicense, rent or lease the Software. Licensors of intellectual property to Nortel are beneficiaries of this provision. Upon termination or breach of the license by Customer or in the event designated hardware or CFE is no longer in use, Customer will promptly return the Software to Nortel or certify its destruction. Nortel may audit by remote polling or other reasonable means to determine Customer's Software activation or usage levels. If suppliers of third party software included in Software require Nortel to include additional or different terms, Customer agrees to abide by such terms provided by Nortel with respect to such third party software.

**2. Warranty.** Except as may be otherwise expressly agreed to in writing between Nortel and Customer, Software is provided "AS IS" without any warranties (conditions) of any kind. NORTEL DISCLAIMS ALL WARRANTIES (CONDITIONS) FOR THE SOFTWARE, EITHER EXPRESS OR IMPLIED, INCLUDING, BUT NOT LIMITED TO THE IMPLIED WARRANTIES OF MERCHANTABILITY AND FITNESS FOR A PARTICULAR PURPOSE AND ANY WARRANTY OF NON-INFRINGEMENT. Nortel is not obligated to provide support of any kind for the Software. Some jurisdictions do not allow exclusion of implied warranties, and, in such event, the above exclusions may not apply.

**3. Limitation of Remedies.** IN NO EVENT SHALL NORTEL OR ITS AGENTS OR SUPPLIERS BE LIABLE FOR ANY OF THE FOLLOWING: a) DAMAGES BASED ON ANY THIRD PARTY CLAIM; b) LOSS OF, OR DAMAGE TO, CUSTOMER'S RECORDS, FILES OR DATA; OR c) DIRECT, INDIRECT, SPECIAL, INCIDENTAL, PUNITIVE, OR CONSEQUENTIAL DAMAGES (INCLUDING LOST PROFITS OR SAVINGS), WHETHER IN CONTRACT, TORT OR OTHERWISE (INCLUDING NEGLIGENCE) ARISING OUT OF YOUR USE OF THE SOFTWARE, EVEN IF NORTEL, ITS AGENTS OR SUPPLIERS HAVE BEEN ADVISED OF THEIR POSSIBILITY. The forgoing limitations of remedies also apply to any developer and/or supplier of the Software. Such developer and/or supplier is an intended beneficiary of this Section. Some jurisdictions do not allow these limitations or exclusions and, in such event, they may not apply.

#### **4. General**

- a. If Customer is the United States Government, the following paragraph shall apply: All Nortel Software available under this License Agreement is commercial computer software and commercial computer software documentation and, in the event Software is licensed for or on behalf of the United States Government, the respective rights to the software and software documentation are governed by Nortel standard commercial license in accordance with U.S. Federal Regulations at 48 C.F.R. Sections 12.212 (for non-DoD entities) and 48 C.F.R. 227.7202 (for DoD entities).
- b. Customer may terminate the license at any time. Nortel may terminate the license if Customer fails to comply with the terms and conditions of this license. In either event, upon termination, Customer must either return the Software to Nortel or certify its destruction.
- c. Customer is responsible for payment of any taxes, including personal property taxes, resulting from Customer's use of the Software. Customer agrees to comply with all applicable laws including all applicable export and import laws and regulations.
- d. Neither party may bring an action, regardless of form, more than two years after the cause of the action arose.
- e. The terms and conditions of this License Agreement form the complete and exclusive agreement between Customer and Nortel.
- f. This License Agreement is governed by the laws of the country in which Customer acquires the Software. If the Software is acquired in the United States, then this License Agreement is governed by the laws of the state of New York.



---

# Contents

---

<b>Preface</b> .....	<b>15</b>
Before you begin .....	15
Text conventions .....	16
How to get Help .....	16
Getting Help from the Nortel Web site .....	16
Getting Help over the phone from a Nortel Solutions Center .....	17
Getting Help from a specialist by using an Express Routing Code .....	17
Getting Help through a Nortel distributor or reseller .....	17
<b>Chapter 1</b>	
<b>Overview</b> .....	<b>19</b>
Physical description .....	19
Front panel .....	20
Shelf circuit breakers (upper and lower shelves) .....	20
Alarm module display panel .....	22
Front panel locking screws .....	24
Back panel .....	24
Shelf alarm connectors (upper and lower shelves) .....	24
Central office alarms .....	26
Power terminal block .....	27
Accessing the alarm module .....	30
Configuration example .....	32
<b>Chapter 2</b>	
<b>Installation</b> .....	<b>33</b>
Preparing to install the breaker interface panel .....	33
Shipment contents .....	34
Additional equipment .....	35

Mounting hardware	35
DC input electrical requirements	35
Installing the breaker interface panel	36
Installing the hardware	36
Connecting cables to the chassis power supplies	38
Routing power supply cables to the BIP	47
Connecting the ground cables to the rack grounding strip	48
Connecting the power supply cables to the BIP	49
Connecting DC input power feeds to the BIP	52
Replacing covers	59
Installing shelf alarm cables	61
Verifying the installation	62
Initial power-up	63
Verifying the LEDs	63
Powering off the system	64
<b>Chapter 3</b>	
<b>Problem solving</b>	<b>67</b>
Interpreting the LEDs	68
Diagnosing and correcting the problem	70
Corrective actions	71
<b>Appendix A</b>	
<b>Technical specifications</b>	<b>73</b>
Environmental	73
Electrical	74
Physical dimensions	74
Electromagnetic emissions	74
Safety agency certification	74
<b>Appendix B</b>	
<b>BIP external cable pin assignments</b>	<b>75</b>
Shelf alarm connectors (J1 and J2)	75
Office alarm connectors (J3 and J4)	77
Standalone office alarm connector (J5)	79



---

**Index ..... 81**



---

## Figures

---

Figure 1	Breaker interface panel . . . . .	19
Figure 2	Front panel components . . . . .	20
Figure 3	Shelf circuit breakers . . . . .	21
Figure 4	Alarm module display panel . . . . .	22
Figure 5	Back panel components . . . . .	24
Figure 6	Shelf alarm connections (upper and lower shelves) . . . . .	25
Figure 7	Configuring multiple BIPs to aggregate office alarms . . . . .	26
Figure 8	Configuring standalone BIPs to report alarm status . . . . .	27
Figure 9	Power terminal block . . . . .	28
Figure 10	Power and grounding example . . . . .	29
Figure 11	Opening the front panel . . . . .	30
Figure 12	Accessing the alarm module . . . . .	31
Figure 13	Default jumper settings . . . . .	31
Figure 14	8010co chassis configuration with BIP option . . . . .	32
Figure 15	Contents of the BIP shipping container . . . . .	34
Figure 16	Removing the plastic back cover from the BIP . . . . .	37
Figure 17	Installing the BIP in the rack . . . . .	37
Figure 18	Removing the 8010co chassis bottom 312096-A bezel . . . . .	39
Figure 19	Location of power supplies . . . . .	40
Figure 20	Loosening the power supply retaining screws . . . . .	41
Figure 21	Disconnecting the power supply from the chassis backplane . . . . .	41
Figure 22	Removing the plastic safety cover from the power supply . . . . .	42
Figure 23	Power supply input and ground stud location . . . . .	42
Figure 24	Power supply cables . . . . .	43
Figure 25	Attaching the ground lead . . . . .	43
Figure 26	Attaching the positive lead . . . . .	44
Figure 27	Attaching the negative lead . . . . .	45
Figure 28	Replacing the plastic safety cover on the power supply . . . . .	45
Figure 29	Replacing the power supply . . . . .	46

Figure 30	Labeling cables for the BIP	47
Figure 31	Rack grounding strip example	48
Figure 32	Attaching power supply cable leads to the BIP	49
Figure 33	Upper and lower shelf power cables connected to the BIP	50
Figure 34	Attaching the BIP ground cable	51
Figure 35	A and B feed example	53
Figure 36	Locating the A and B -48 VDC input feeds	54
Figure 37	Connecting the A and B -48 VDC input feeds to the BIP (1 of 2)	55
Figure 38	Connecting the A and B -48 VDC input feeds to the BIP (2 of 2)	56
Figure 39	Connecting the A/B input feed returns (1 of 2)	57
Figure 40	Connecting the A/B input feed returns (2 of 2)	58
Figure 41	Replacing the plastic back cover on the BIP	59
Figure 42	Replacing the 8010co chassis 312096-A bezel	60
Figure 43	Installing shelf alarm cables	61
Figure 44	BIP LEDs and indicators	68
Figure 45	J1 and J2 9-pin standard D-sub connector	75
Figure 46	J1 and J2 shelf alarm connector pinouts	76
Figure 47	J3 and J4 high-density 26-pin D-sub connector	77
Figure 48	J3 and J4 office alarm connectors	77
Figure 49	J5 high-density 26-pin D-sub connector	79
Figure 50	J5 standalone office alarm connector	79

---

## Tables

---

Table 1	Alarm module display LEDs .....	22
Table 2	DC power requirements .....	35
Table 3	Single chassis and dual chassis input options .....	53
Table 4	BIP LEDs and indicators .....	68
Table 5	Corrective actions .....	71
Table 6	J1 and J2 shelf alarm connector pin assignments .....	76
Table 7	J3 and J4 office alarm connector pin assignments .....	78
Table 8	J5 standalone office alarm connector pin assignments .....	80



## Preface

---

The breaker interface panel (BIP) provides power distribution and alarm status indications for one or two 8010co chassis in an equipment rack. The status indications can be linked to other BIPs to provide total system status to the central office (CO).

This guide describes how to install the breaker interface panel in an equipment rack, connect cables, and interpret LEDs. It also includes technical specifications for the breaker interface panel.

For a list of related publications, see the release notes that accompany your software.

## Before you begin

This guide is intended for qualified service personnel who need to install or replace a breaker interface panel. A qualified service person must have appropriate technical training and experience and be aware of hazards involved in installing and replacing customer-replaceable units (CRUs).

## Text conventions

This guide uses the following text conventions:

<b>bold Courier text</b>	Indicates command names and options and text that you need to enter. Example: Use the <b>dinfo</b> command. Example: Enter <b>show ip {alerts routes}</b> .
<i>italic text</i>	Indicates new terms, book titles, and variables in command syntax descriptions. Where a variable is two or more words, the words are connected by an underscore. Example: If the command syntax is <code>show at &lt;valid_route&gt;</code> , <i>valid_route</i> is one variable and you substitute one value for it.
plain Courier text	Indicates command syntax and system output, for example, prompts and system messages. Example: Set Trap Monitor Filters

## How to get Help

This section explains how to get help for Nortel products and services.

### Getting Help from the Nortel Web site

The best way to get technical support for Nortel products is from the Nortel Technical Support Web site:

<http://www.nortel.com/support>

This site provides quick access to software, documentation, bulletins, and tools to address issues with Nortel products. More specifically, the site enables you to:

- download software, documentation, and product bulletins
- search the Technical Support Web site and the Nortel Knowledge Base for answers to technical issues



- sign up for automatic notification of new software and documentation for Nortel equipment
- open and manage technical support cases

### **Getting Help over the phone from a Nortel Solutions Center**

If you don't find the information you require on the Nortel Technical Support Web site, and have a Nortel support contract, you can also get help over the phone from a Nortel Solutions Center.

In North America, call 1-800-4NORTEL (1-800-466-7835).

Outside North America, go to the following Web site to obtain the phone number for your region:

<http://www.nortel.com/callus>

### **Getting Help from a specialist by using an Express Routing Code**

To access some Nortel Technical Solutions Centers, you can use an Express Routing Code (ERC) to quickly route your call to a specialist in your Nortel product or service. To locate the ERC for your product or service, go to:

<http://www.nortel.com/erc>

### **Getting Help through a Nortel distributor or reseller**

If you purchased a service contract for your Nortel product from a distributor or authorized reseller, contact the technical support staff for that distributor or reseller.



---

# Chapter 1

## Overview

---

This chapter provides an overview of the BIP and covers the following topics:

- [Physical description](#)
- [“Accessing the alarm module” on page 30](#)
- [“Configuration example” on page 32](#)

## Physical description

The BIP provides a central rack location where redundant input DC power feeds are connected and routed to one or two 8010co chassis. The BIP also provides an alarm module and display panel that monitors system components, generates alarms, and controls LED status indicators (requires 8010co chassis configured with an 8691SF or 8691omSF CPU Module). The alarm module provides total system status to the central office.

[Figure 1](#) shows the breaker interface panel. Descriptions of the front panel components follow the figure.

**Figure 1** Breaker interface panel

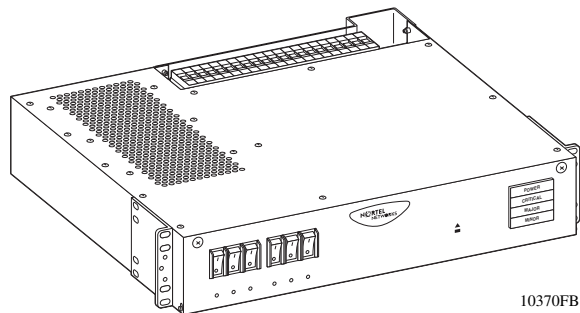

## Front panel

Figure 2 shows the BIP front panel components.

**Figure 2** Front panel components

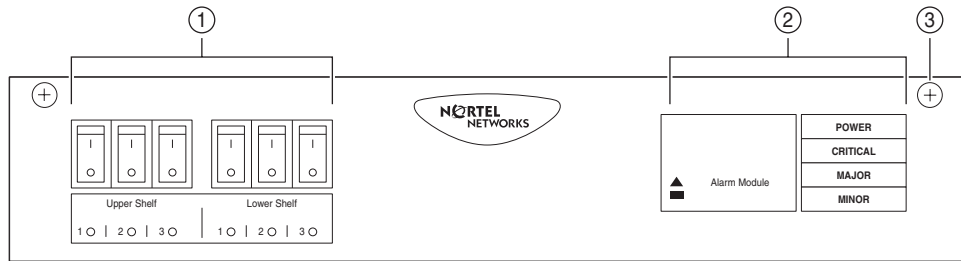

- 1 = Shelf circuit breakers (upper/lower shelves)
- 2 = Alarm module display panel
- 3 = Front-panel locking screws (x2)

10376EB

### Shelf circuit breakers (upper and lower shelves)

Two groups of three circuit breakers provide input power to the power supplies for the upper and lower shelf 8010co chassis (Figure 3 on page 21):

- The first group, labeled “Upper Shelf,” provides input power to the upper shelf power supplies.
- The second group, labeled “Lower Shelf,” provides input power to the lower shelf power supplies.

If a power supply over current condition occurs, the associated circuit breaker trips and indicates the fault by lighting the associated circuit breaker’s LED (red).

Each of the six circuit breakers is current limited to 30 amperes @80 volts direct current. The circuit breakers are designed with internal auxiliary switches to provide fault indications to the alarm module and to the associated circuit breaker LEDs on the front panel. The alarm module reports circuit breaker fault conditions by lighting the MAJOR indicator on the Alarm Module display panel.

No alarm is generated to the alarm module when the circuit breaker is manually switched on (I) or off (O).

**Figure 3** Shelf circuit breakers

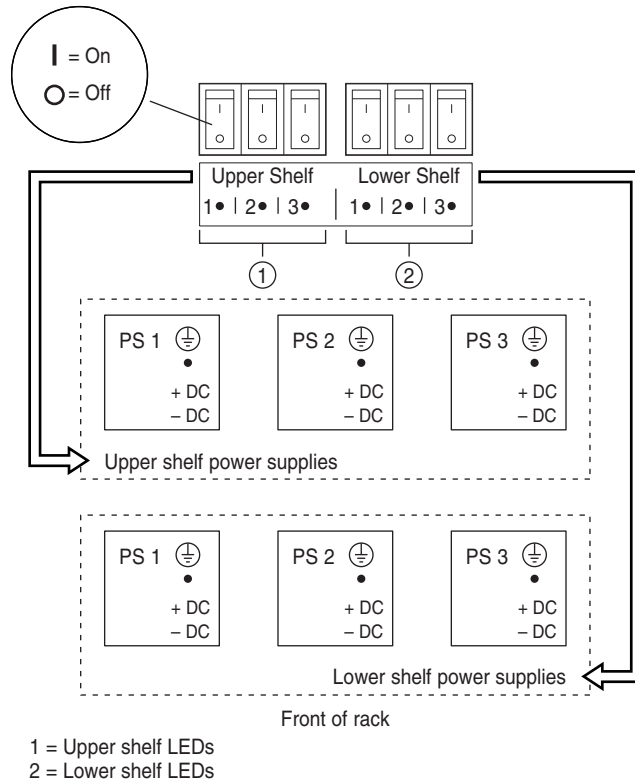

10372EA

## Alarm module display panel

The alarm module display panel (Figure 4), located on the BIP front panel, provides visual status indications for one or two 8010co chassis in a single rack.

**Figure 4** Alarm module display panel

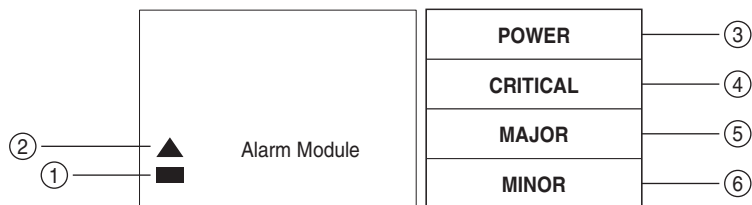



1 = Shelf alarm cable validation LED    3 = POWER indicator    5 = MAJOR fault indicator  
 2 = Shelf alarm cable fault LED    4 = CRITICAL fault indicator    6 = MINOR fault indicator

10377EA

See [Table 1](#) for a description of the LEDs.

**Table 1** Alarm module display LEDs

Item	Label/Icon	Type	Color/State	Description
1		LED	Green/On steady	Shelf alarm cable validation LED—The alarm cables are properly connected to the shelves.
2		LED	Red/On steady	Shelf alarm cable fault LED—The shelf alarm cables are missing, not secured, or the shelf alarm jumpers are not configured properly (see <a href="#">“Accessing the alarm module” on page 30</a> ). This fault condition also lights the MINOR indicator (see Minor fault description in this table).
3	POWER	Indicator	White/On steady	Power indicator—The external DC power is available to the BIP.
4	CRITICAL	Indicator	Red/On steady	Critical fault indicator—Indicates that a severe service-affecting condition has occurred that requires immediate corrective action. Common causes for this type of fault condition include: <ul style="list-style-type: none"> <li>• Line card failure</li> <li>• Temperature fault</li> <li>• CPU fault when only one CPU is installed</li> </ul>

**Table 1** Alarm module display LEDs (continued)

Item	Label/Icon	Type	Color/State	Description
5	MAJOR	Indicator	Red/On steady	<p>Major fault indicator—Indicates that the system hardware or software has identified a serious disruption of service or that an important circuit failure has occurred.</p> <p>Common causes for this type of fault condition include:</p> <ul style="list-style-type: none"> <li>• CPU fault when two CPUs are installed</li> <li>• Two fan trays are faulty</li> <li>• Two power supplies are faulty</li> </ul>
6	MINOR	Indicator	Yellow/On steady	<p>Minor fault indicator—Indicates a problem that does not have a serious effect on customer service, or a problem in circuits that are not essential to device operation.</p> <p>Common causes for this type of fault condition include:</p> <ul style="list-style-type: none"> <li>• Shelf alarm cables not installed or not connected properly.</li> <li>• Alarm module jumpers configured incorrectly.</li> <li>• One power supply is faulty</li> <li>• One fan tray is faulty</li> </ul>

The alarm module can also be linked to other BIPs, and can provide visual and audible alarms to aisle alarms and to the central office (see [“Central office alarms” on page 26](#)).

Alarm support for the BIP is provided by the 8691SF or 8691omSF central processing unit (CPU) in the 8010co chassis. The following conditions in the 8010co chassis generate alarms:

- Power supply failure
- Fan failure
- Overheating
- Line card error
- Master CPU failure

For details about the 8691SF or 8691omSF Central Processing Unit (CPU), see the appropriate product chassis installation manual.

## Front panel locking screws

The front panel locking screws allow you to open the front panel to access the alarm module. The alarm module contains jumpers that you use to configure your system alarm parameters.

For information about configuring your system alarm parameters, see [“Accessing the alarm module” on page 30](#).

## Back panel

[Figure 5](#) shows the BIP back panel configuration (plastic back cover not shown).

Descriptions of the back panel components follow the figure.

**Figure 5** Back panel components

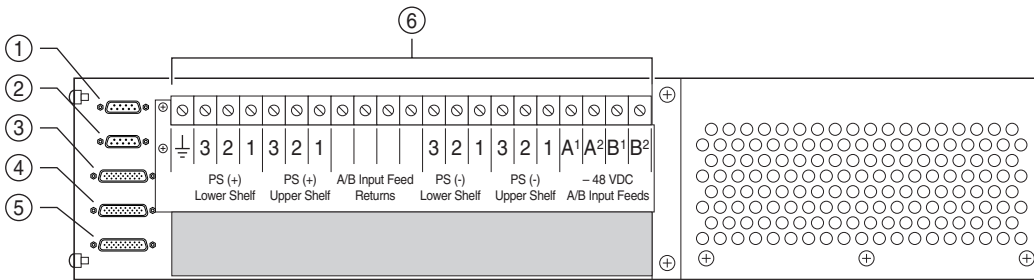

- |                                    |                                   |  |
|------------------------------------|-----------------------------------|--|
| 1 = J1 Upper shelf alarm connector | 3 = J3 Central office alarm "in"  | 5 = J5 Standalone office alarm connector |
| 2 = J2 Lower shelf alarm connector | 4 = J4 Central office alarm "out" | 6 = TB1 Power terminal block             |

10367EA

## Shelf alarm connectors (upper and lower shelves)

The shelf alarm connectors allow you to configure the BIP to control more than one 8010co chassis.



**Note:** The BIP ships from the factory with default alarm configurations set for a single chassis in the lower shelf of the rack. If you install a second chassis, you must also configure the jumper on the alarm module to support that configuration. See [“Accessing the alarm module” on page 30](#) for information about jumper settings for your configuration.



Figure 6 shows the location of the shelf alarm connectors on the BIP and on two 8010co chassis (upper and lower shelves).

**Figure 6** Shelf alarm connections (upper and lower shelves)

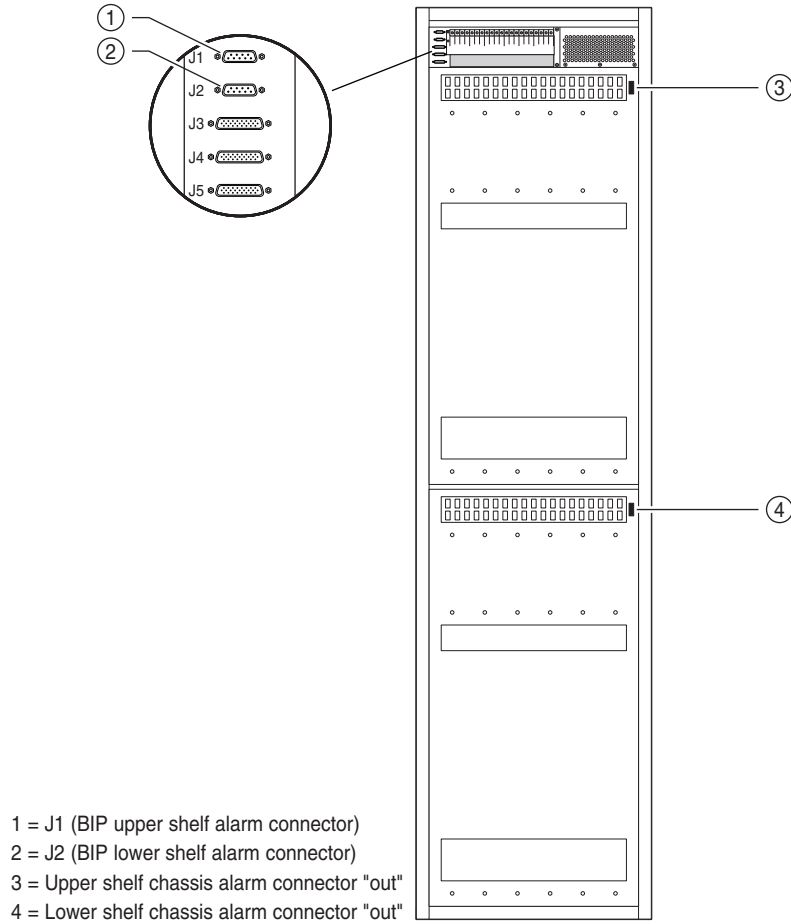

10380EA

## Central office alarms

The central office alarm connectors allow you to aggregate alarms from multiple BIPs and route them to an aisle alarm and to the central office. [Figure 7](#) shows three BIPs configured to aggregate alarms from three racks. You can configure up to ten BIPs in a series configuration to aggregate alarms.

Central office alarm cables are not provided as part of your BIP shipment. To build your own central office alarm cables, see [Appendix B, “BIP external cable pin assignments,”](#) on page 75.

**Figure 7** Configuring multiple BIPs to aggregate office alarms

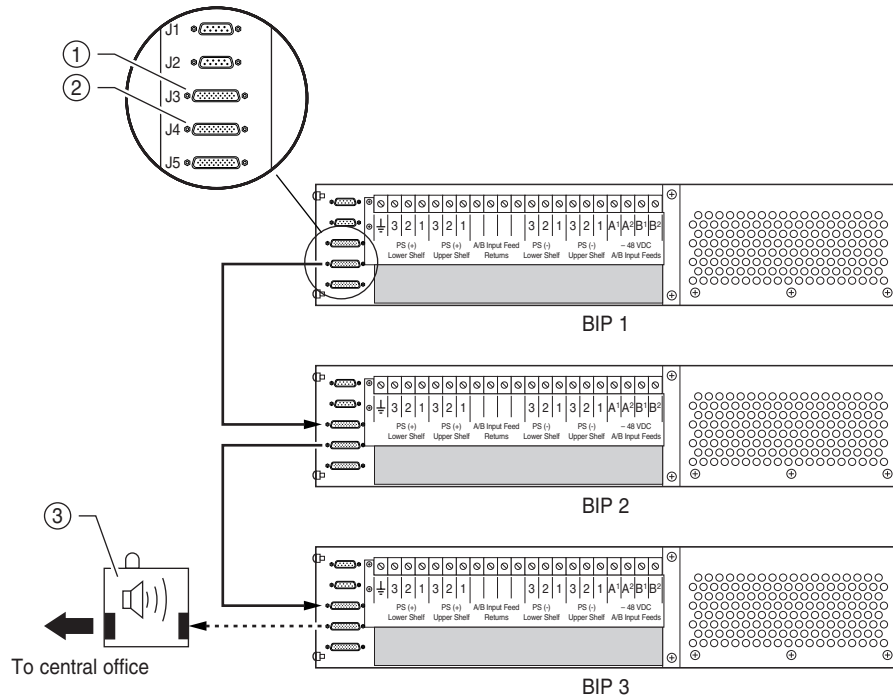

- 1 = J3 (central office alarm "in")
- 2 = J4 (central office alarm "out")
- 3 = Aisle alarm

10371EA

You can also configure one or more standalone BIPs to individually report alarm status to the central office ([Figure 8](#) on page 27).

This type of configuration allows you to independently monitor and control the external audible and visual alarm status indications of the BIP at the central office.

**Figure 8** Configuring standalone BIPs to report alarm status

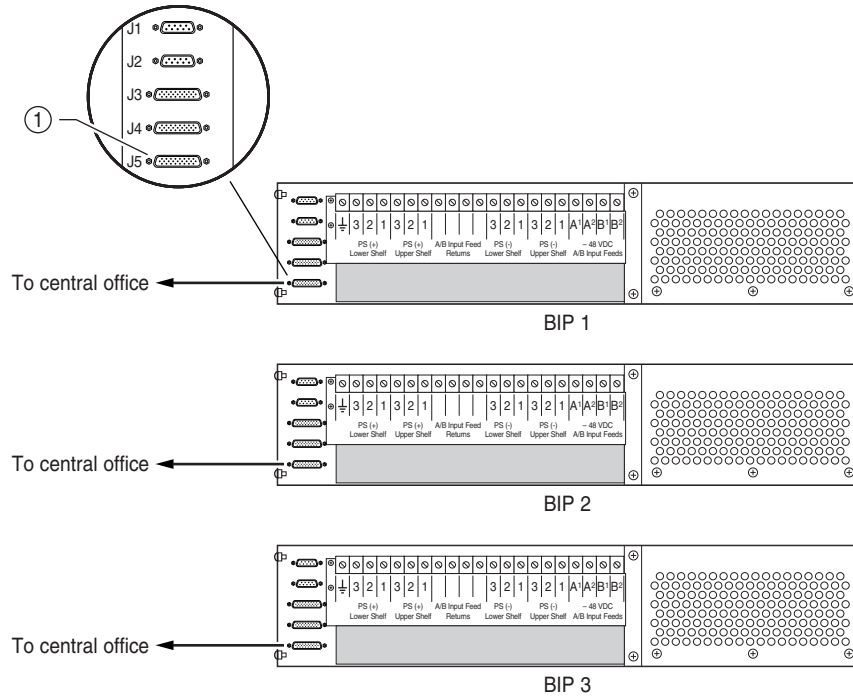

1 = J5 (standalone office alarm connector)

10419EA

## Power terminal block

The power terminal block is located on the back panel of the BIP. As shown in [Figure 9 on page 28](#), the power terminal block provides 21 connection blocks for DC input and output feeds.

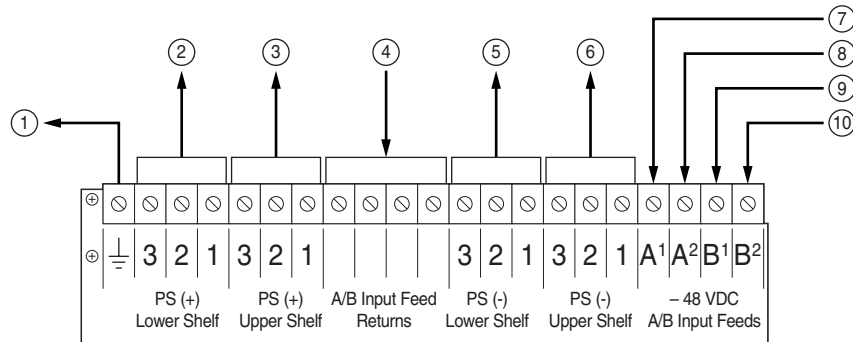
**Figure 9** Power terminal block

- |   |   |
|---|---|
| 1 = To frame (rack) ground                        | 6 = To upper shelf power supplies (-DC terminals) |
| 2 = To lower shelf power supplies (+DC terminals) | 7 = -48 VDC input feed (Primary A feed)           |
| 3 = To upper shelf power supplies (+DC terminals) | 8 = -48 VDC input feed (Secondary A feed)         |
| 4 = Returns (A/B input feeds)                     | 9 = -48 VDC input feed (Primary B feed)           |
| 5 = To lower shelf power supplies (-DC terminals) | 10 = -48 VDC input feed (Secondary B feed)        |

10379EA

Figure 10 on page 29 shows an example of the BIP power terminal block cabling including ground connections for two 8010co chassis and installed power supplies.

As shown in this example, both upper and lower chassis are each fully configured with three power supplies (one is redundant) and require four 60 A direct current input feeds to the BIP (two feeds are redundant).

For more information, see “Connecting DC input power feeds to the BIP” on page 52.



**Caution:** All DC input feeds to the breaker interface panel must be equipped with an overcurrent protection device that limits current to a maximum of 60 A. The overcurrent protection device can be any approved, standard-delay, 60 A fuse or circuit breaker with an interrupting current rating of not less than 10,000 A.

Figure 10 Power and grounding example

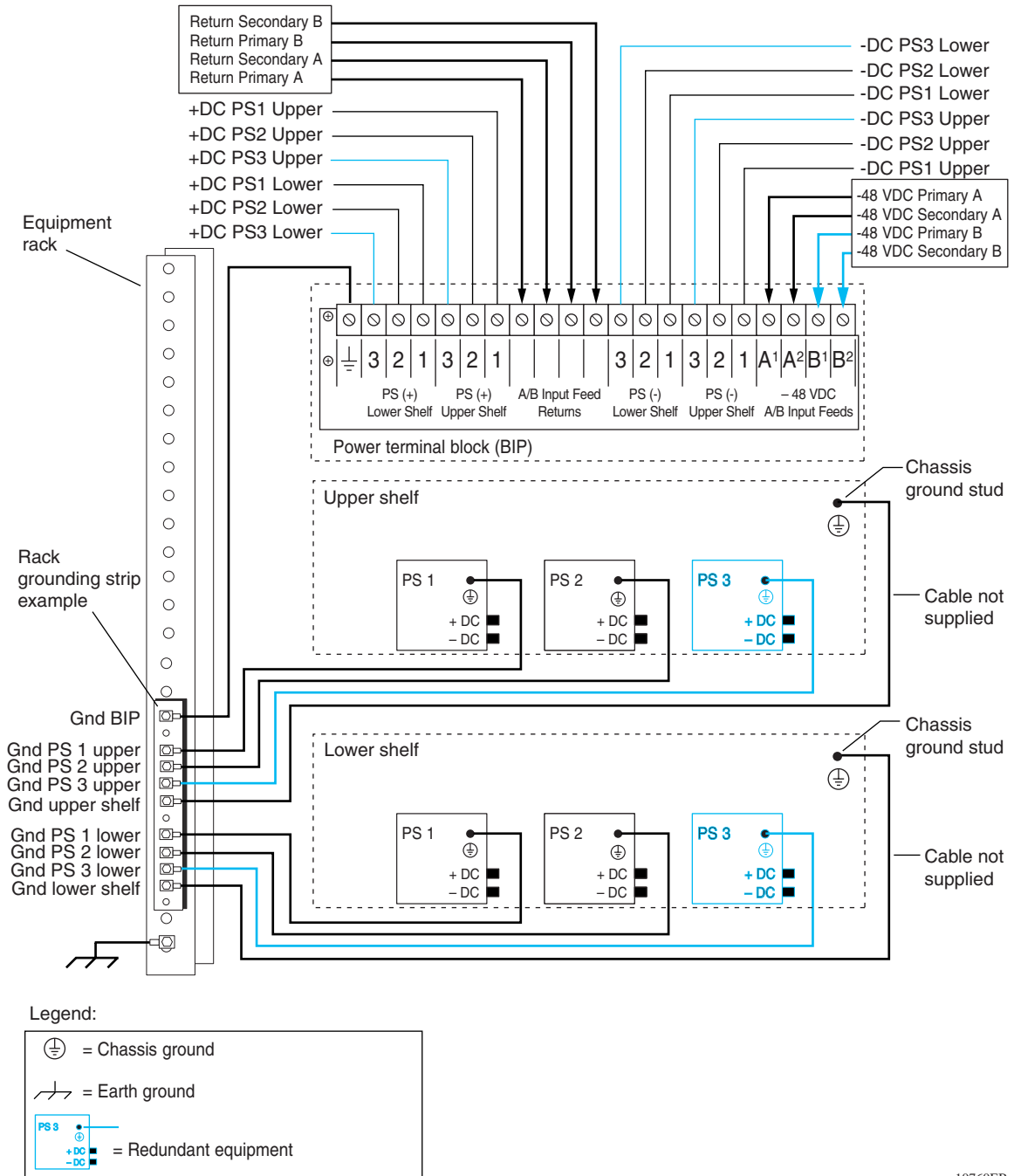

10760EB

## Accessing the alarm module



**Danger:** Ensure that the DC power source is off or disconnected at the remote end before you perform any of the steps in this section. Be sure that the DC input source power is locked out and tagged.

The alarm module contains jumpers that you can configure to allow the BIP to monitor the shelf alarm cables for a single or dual chassis installation. The BIP ships from the factory with default jumper configurations set for a single chassis in the lower shelf of the rack. If you install a second chassis in the upper shelf, you must configure the jumpers on the alarm module to support that configuration.



**Note:** The jumper configuration has no affect on the chassis status alarms.

The BIP front panel opens to provide access to the jumpers on the alarm module.

To open the front panel:

- 1 Using a Phillips screwdriver, loosen the two front panel locking screws (Figure 11).

**Figure 11** Opening the front panel

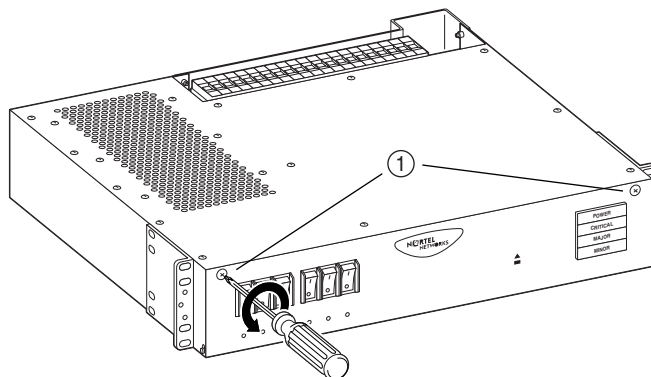

1 = Front panel locking screws (x 2)

10375FB

2 Gently lower the front panel to expose the alarm module (Figure 12).

**Figure 12** Accessing the alarm module

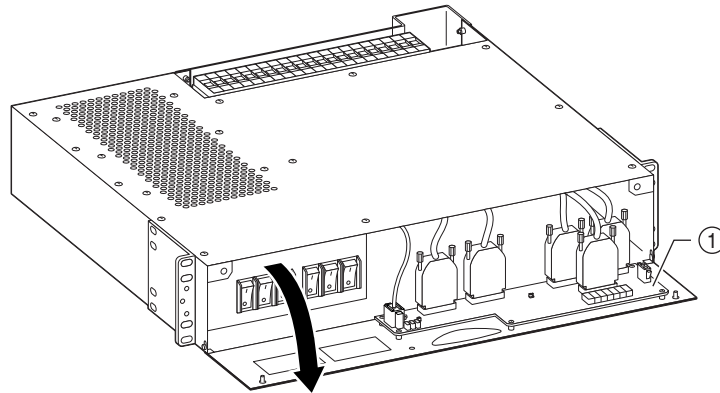

1 = Alarm module

10365FB

Figure 13 shows a close-up view of the alarm module with jumpers J8 and J9 configured to monitor the shelf alarm cable for a single chassis in the lower shelf only (default setting). Monitoring of the upper shelf alarm cable is disabled with jumper J8, by default.

To enable the BIP to monitor the shelf alarm cable for a second chassis in the upper shelf, you must place the upper shelf alarm jumper (J8) over pins 2 and 3.

**Figure 13** Default jumper settings

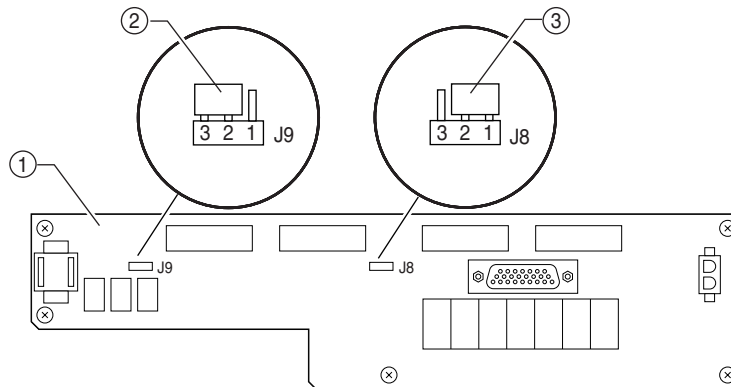

1 = Alarm module

2 = J9 Lower shelf alarm jumper (enabled)

3 = J8 Upper shelf alarm jumper (disabled)

10366EB

## Configuration example

Figure 14 shows a typical configuration using the optional breaker interface panel.

**Figure 14** 8010co chassis configuration with BIP option

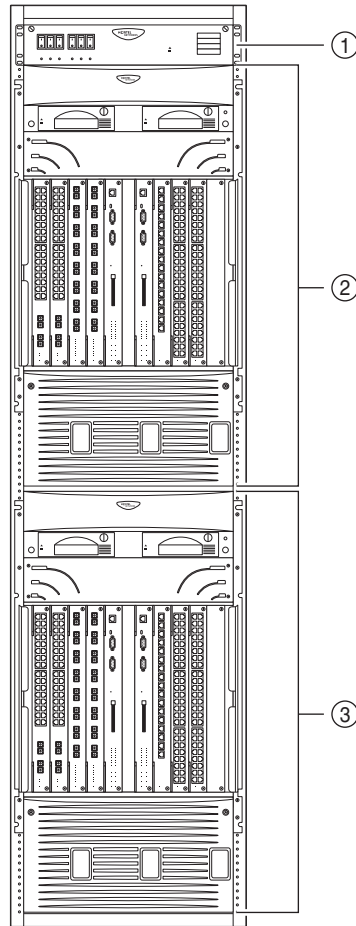

- 1 = Breaker interface panel
- 2 = 8010co Chassis (upper shelf position)
- 3 = 8010co Chassis (lower shelf position)

10420EB



---

## Chapter 2

# Installation

---

This chapter describes how to install the breaker interface panel and covers the following topics:

- [“Preparing to install the breaker interface panel”](#) next
- [“Installing the breaker interface panel”](#) on page 36
- [“Verifying the installation”](#) on page 62

## Preparing to install the breaker interface panel

Before begin the installation, verify that:

- Your shipment is complete and undamaged.
- You have the cables, tools, and other equipment that you need.
- Your installation site meets the physical, electrical, and environmental requirements (see [Appendix A, “Technical specifications,”](#) on page 73).

The sections that follow help you prepare for installation.



**Note:** For a list of requirements that must be met for the 8010co chassis, see the appropriate product chassis installation manual.

---

## Shipment contents

Inspect all items for shipping damage. If you detect any damage, do not install the BIP. Call the Nortel Technical Solutions Center in your area (see [“How to get Help”](#) on page 16).

Your BIP shipment contains the following items ([Figure 15](#)):

**Figure 15** Contents of the BIP shipping container

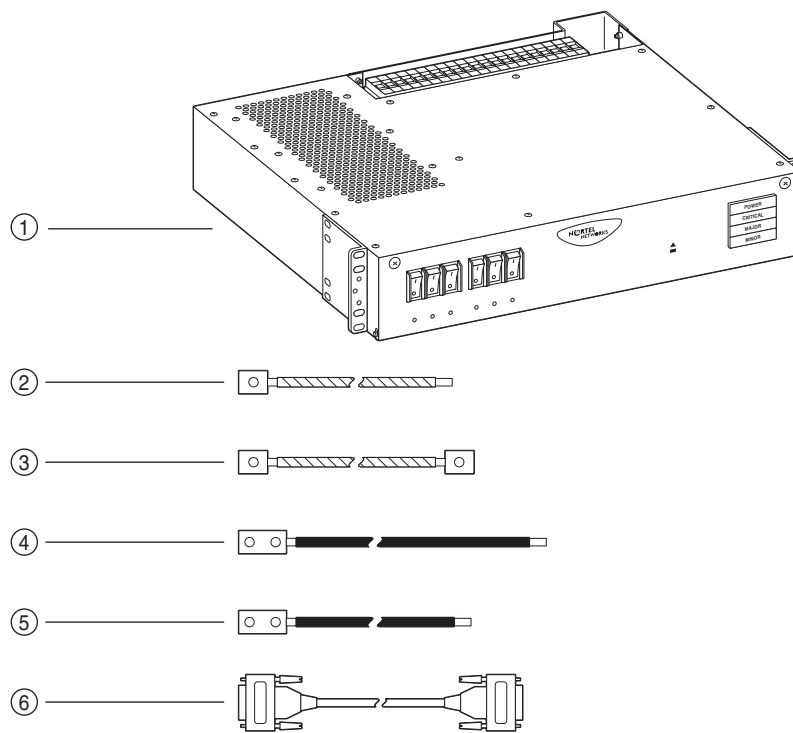

- |   |                                       |
|---|---------------------------------------|
| 1 = Breaker interface panel (BIP)           | 4 = 125-inch power supply cable (x 6) |
| 2 = BIP ground cable (x 1)                  | 5 = 90-inch power supply cable (x 6)  |
| 3 = 90-inch power supply ground cable (x 6) | 6 = Shelf alarm cables (x 2)          |

10369FC

## Additional equipment

To install the BIP, you might need items that are not part of the BIP installation kit. Before installing the BIP hardware, ensure that you obtain all the cables, tools, and other equipment that you need. For information about office alarm cable pin assignments, see [Appendix B, “BIP external cable pin assignments,” on page 75](#).

## Mounting hardware

You must install the BIP in an equipment rack. You need the following tools:

- Phillips screwdriver
- 7/16-inch hex wrench

You also need a rack that meets the following specifications:

- Heavy-duty steel construction
- Electronics Industries Association (EIA) standard hole-spacing

You can install the BIP in the following 19-in. (48.26 cm) rack configurations:

- Standard 19-inch rack
- Hendry rack

You can install the BIP in a standard 23-inch rack using adapters provided by the rack supplier. If your rack does not have threaded rail holes, you must use cagenuts that are appropriate for the specific rack model you are using.

## DC input electrical requirements

The installation site must meet the following electrical requirements for DC power ([Table 2](#)):

**Table 2** DC power requirements

Nominal input voltage	Maximum input current	Physical
-48 VDC nominal	60 A	Reinforced insulation from the main DC power

## Installing the breaker interface panel

---



**Warning:** Ensure that the DC power source is off or disconnected at the remote end before you perform any of the steps in this section. You may need to switch a circuit breaker off or turn off power at the DC input source. Be sure that the DC input source power is locked out and tagged.

---



**Note:** The 8004DC power supply operates with the BIP. The BIP does not support the 8005DC power supply.

---

This section covers the following topics:

- [“Installing the hardware”](#) next
- [“Connecting cables to the chassis power supplies”](#) on page 38
- [“Routing power supply cables to the BIP”](#) on page 47
- [“Connecting the ground cables to the rack grounding strip”](#) on page 48
- [“Connecting the power supply cables to the BIP”](#) on page 49
- [“Connecting DC input power feeds to the BIP”](#) on page 52
- [“Replacing covers”](#) on page 59
- [“Installing shelf alarm cables”](#) on page 61

### Installing the hardware

Before beginning the BIP hardware installation, ensure that you:

- Always install the BIP in the uppermost position in the rack to allow for maximum convection cooling requirements.
- Ground the rack to the same grounding electrode used by the power service in the area.

The ground path must be permanent and must not exceed 1 ohm of resistance from the rack to the grounding electrode.

To install the BIP:

- 1 Remove the plastic back cover from the BIP terminal block (Figure 16).

**Figure 16** Removing the plastic back cover from the BIP

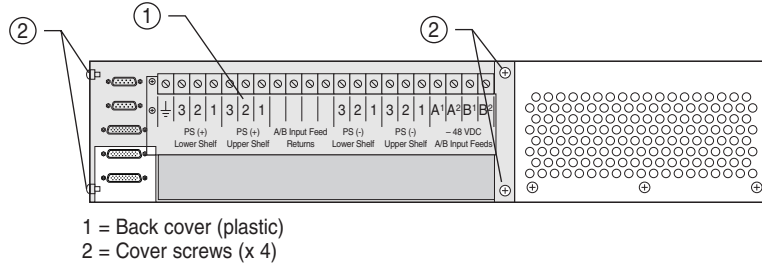

10421FA



**Caution:** The BIP weighs 33.9 lbs (15.4 kg). The next step requires two persons to mount the BIP in the rack.

- 2 Position the BIP in the uppermost position in the rack and align the holes in the mounting bracket with the holes in the rack.
- 3 Insert 2 screws, appropriate for your rack type, into each mounting bracket and tighten them (Figure 17).

**Figure 17** Installing the BIP in the rack

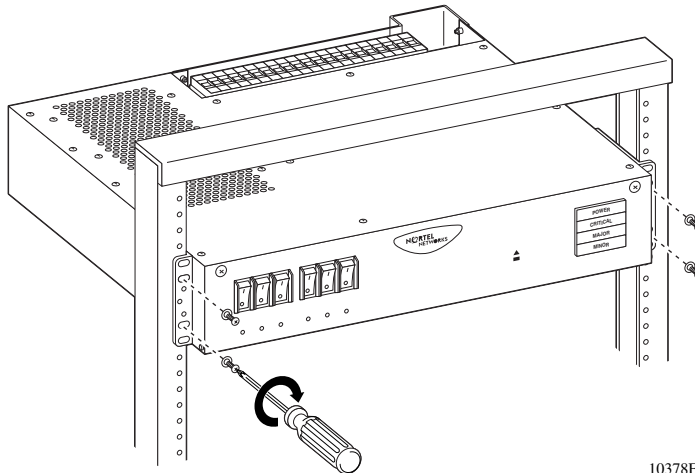

10378FB

- 4 After the BIP is secured in the rack, go to the next section, “Connecting cables to the chassis power supplies” on page 38.

## Connecting cables to the chassis power supplies

This section describes how to connect the BIP power cables to the 8010co chassis 8004DC power supplies. These procedures assume that all required power supplies were previously installed during the 8010co chassis installation.



**Note:** This guide does not describe how to remove or replace power supplies in the 8010co chassis. For detailed instructions about adding power supplies or modifying an existing configuration, see the appropriate product chassis installation manual.

---

Before beginning the procedures in this section, note the following:

- A 8010co chassis configuration can consist of one or two chassis in a single rack. If a single chassis is installed, it is always installed in the lower shelf position.



**Note:** For a single chassis installation, always install the chassis in the lower shelf position to stabilize the rack.

---

- Each chassis can be configured with up to three power supplies. The cabling for each power supply comprises three conductors: the positive lead wire, the negative lead wire, and the ground lead.
- To access the power supplies, you may have to remove the bottom front bezel from both the upper shelf and lower shelf 8010co chassis.



**Warning:** Ensure that the DC power source is off or disconnected at the remote end before you perform any of the steps in this section. You may need to switch a circuit breaker off or turn off power at the DC input source. Be sure that the DC input source power is locked out and tagged.

---



**Note:** The 321325-A bezel does not need to be removed to access the power supplies.

---

To connect cables to the chassis power supplies:

- 1** Remove the 8010co chassis bottom bezels (if required).
  - a** Using a Phillips screwdriver, loosen the 2 captive screws securing the bezel to the chassis ([Figure 18](#)).
  - b** Pull the top of the bezel forward and then lift the 312096-A bezel from the two tabs on the bottom of the chassis.
  - c** Repeat steps **a** and **b** for the second chassis, if installed.

**Figure 18** Removing the 8010co chassis bottom 312096-A bezel

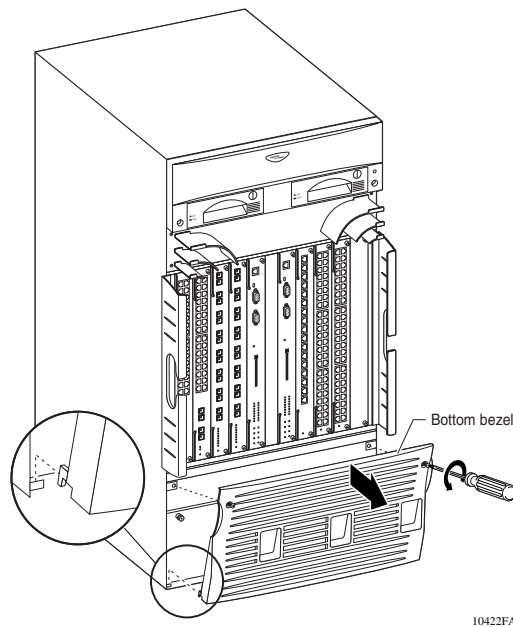

**2** Locate the power supplies ([Figure 19](#)).

With the bezel removed, you can see the power supplies. The chassis can contain up to three power supplies. (Power supplies reside in bay 1, bay 2, and bay 3, viewed left to right from the front of the chassis.)

**Figure 19** Location of power supplies

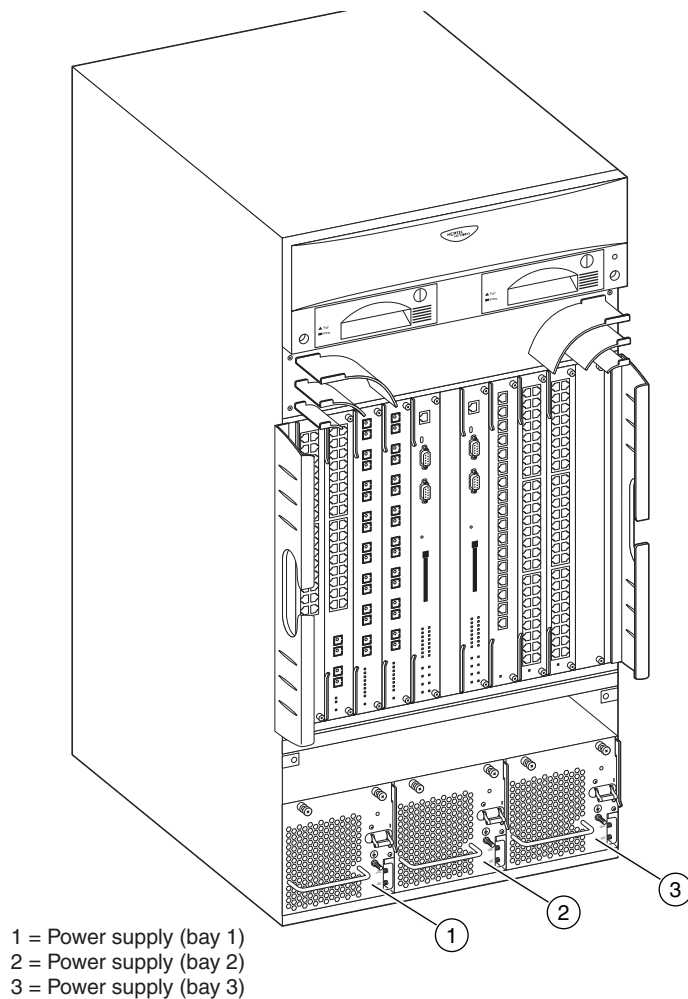

10423FA



- 3 Loosen the 2 retaining screws on the power supply located in bay 1 in the lower chassis (Figure 20).

**Figure 20** Loosening the power supply retaining screws

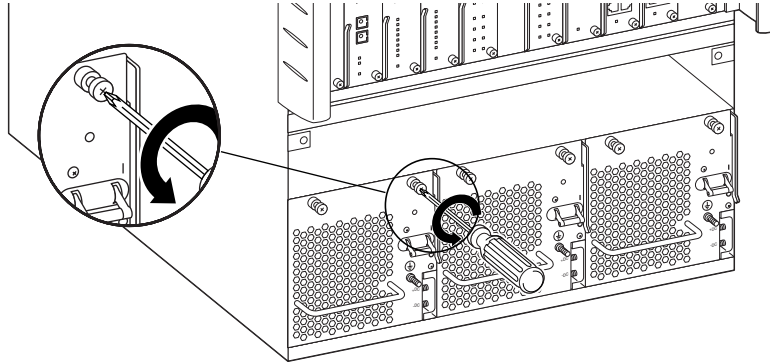

10424FA

- 4 Lift the extractor lever to disconnect the power supply from the backplane connector, and then pull the power supply partially out of the chassis (Figure 21).

**Figure 21** Disconnecting the power supply from the chassis backplane

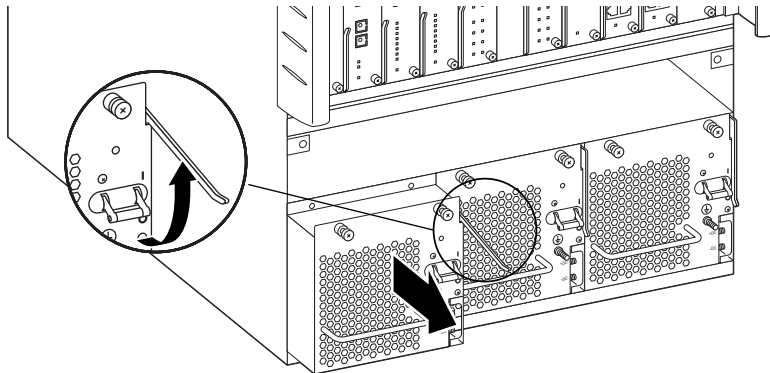

10425FA

- 5 Remove the Phillips screw securing the plastic safety cover to the power supply, and then remove the cover (Figure 22).

Save the Phillips screw and the cover for replacement later.

**Figure 22** Removing the plastic safety cover from the power supply

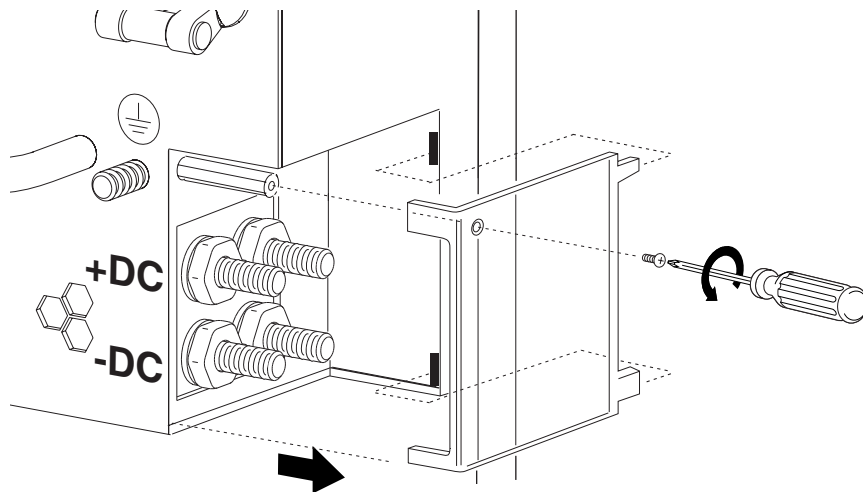

10426FA

- 6 Note the position of the ground stud and of the positive and negative power supply inputs (Figure 23).

**Figure 23** Power supply input and ground stud location

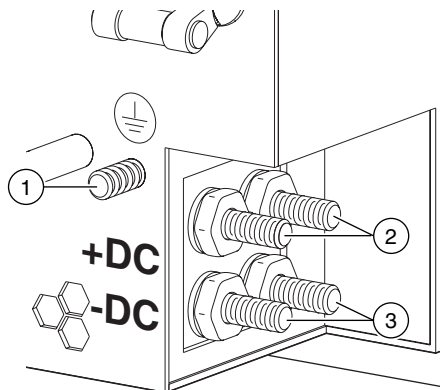

- 1 = Ground stud
- 2 = Positive power inputs
- 3 = Negative power inputs

10427FA

- 7 Locate the following items in the shipping container (Figure 24).
- 125-inch power cables—for power supplies located in the lower chassis
  - 90-inch power cables—for power supplies located in the upper chassis
  - 90-inch ground cables—for grounding of power supplies located in the upper and lower chassis

**Figure 24** Power supply cables

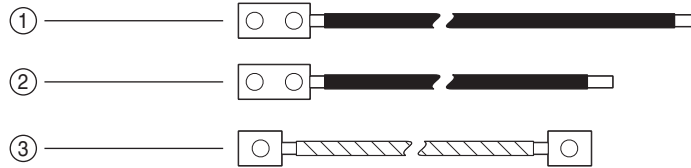

- 1 = 125-inch power supply cables (x 6)  
 2 = 90-inch power supply cables (x 6)  
 3 = 90-inch power supply ground cables (x 6)

10428FC

- 8 Attach one end of a 90-inch ground cable to the grounding stud on the power supply. Use a 7/16-inch hex wrench to fasten the hardware in the correct order (Figure 25).

The hardware (washers and nuts) are included with the power supply shipment.

**Figure 25** Attaching the ground lead

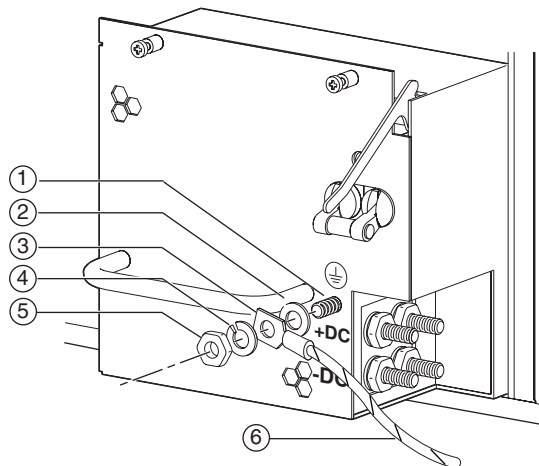

- 1 = Grounding stud      4 = Lock washer  
 2 = Flat washer        5 = Hex nut  
 3 = Crimp lug          6 = Earth ground lead

10297FA

- 9 Attach the lug end of a 125-inch power supply cable to the positive terminal on the power supply (Figure 26).

Use a 7/16-inch hex wrench to fasten the hardware in the correct order.

**Figure 26** Attaching the positive lead

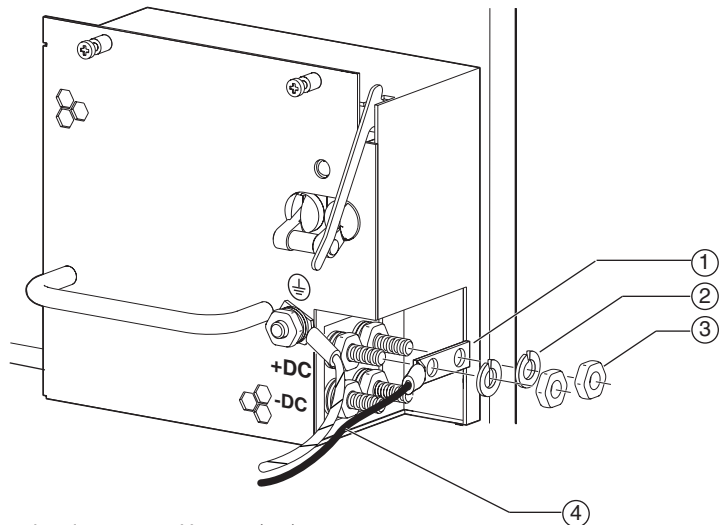

- 1 = Two-hole crimp lug      3 = Hex nut (x 2)  
2 = Lock washer (x 2)      4 = Positive lead wire

10429FA

- 10** Attach the lug end of a 125-inch power supply cable to the negative terminal on the power supply (Figure 27).

Use a 7/16-inch hex wrench to fasten the hardware in the correct order.

**Figure 27** Attaching the negative lead

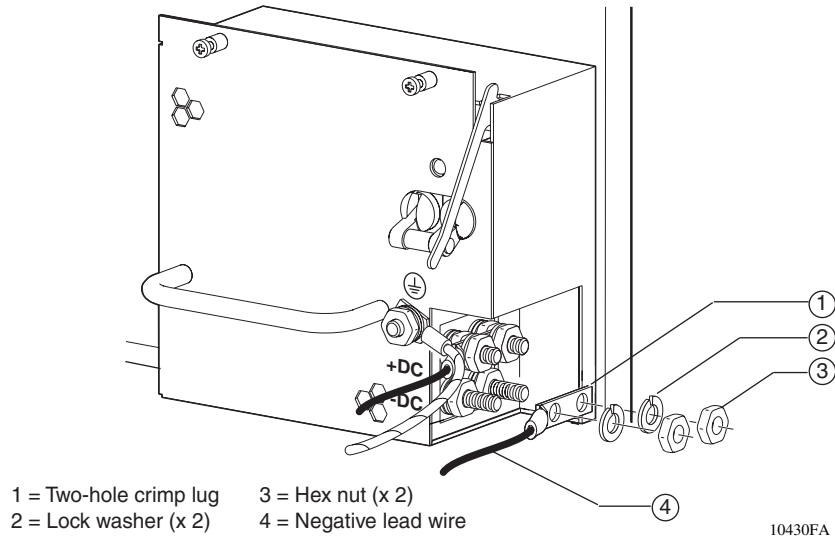

- 11** Replace the plastic safety cover on the power supply (Figure 28).

**Figure 28** Replacing the plastic safety cover on the power supply

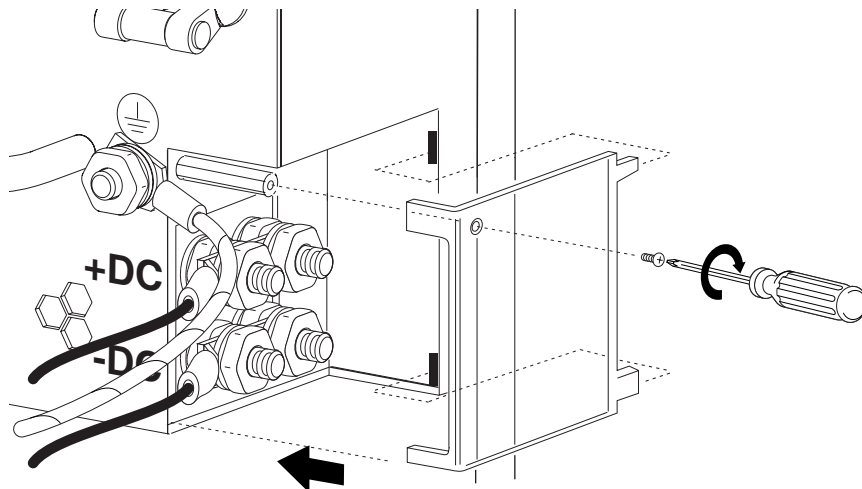

- 12** Secure the power supply in bay 1 of the lower chassis ([Figure 29](#)).
  - a** Use the power supply handle to push the power supply firmly into bay 1.
  - b** Push the extractor lever down to lock the power supply in place.
  - c** Tighten the two power supply retaining screws.

**Figure 29** Replacing the power supply

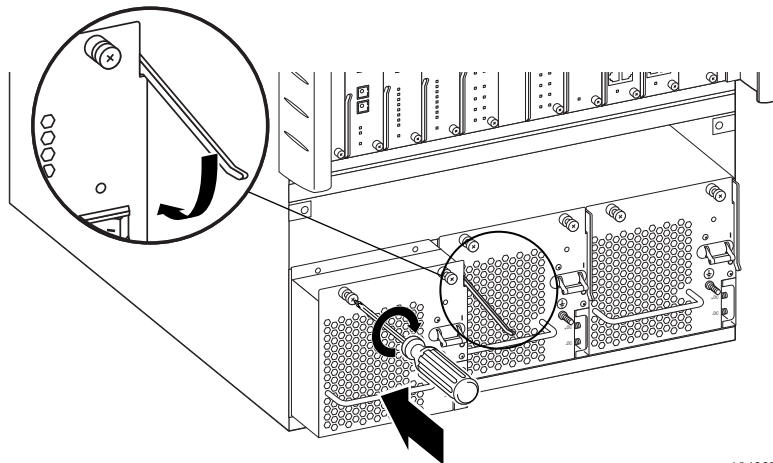

10432FB

- 13** Perform steps [3](#) through [12](#) for each power supply in the system configuration, including the upper shelf chassis, if installed.

Use the shorter, 90-inch power cables for upper shelf power supplies.
- 14** After all power supplies are cabled, go to the next section, [“Routing power supply cables to the BIP”](#) on page [47](#).

## Routing power supply cables to the BIP

After you connect all cables to the chassis power supplies, you must route the power supply cable leads from each chassis to the BIP. If you installed an upper and lower shelf chassis, and each chassis has three power supplies, you have 18 separate cables to route to the BIP. For this reason, Nortel recommends that you label the cables and loosely bundle and fasten them with tie-wraps along the path.

To route the cables to the BIP:

- 1 Label the unconnected ends of the cable leads for each power supply according to their destination on the BIP (Figure 30).

Figure 30 shows an example of one set of power supply cables for a power supply that is located in bay 1 of the upper shelf chassis. The cables were preassembled with the appropriate crimp lugs.

Be sure to label the cable leads appropriately for the power supplies in both the upper and lower shelves.

**Figure 30** Labeling cables for the BIP

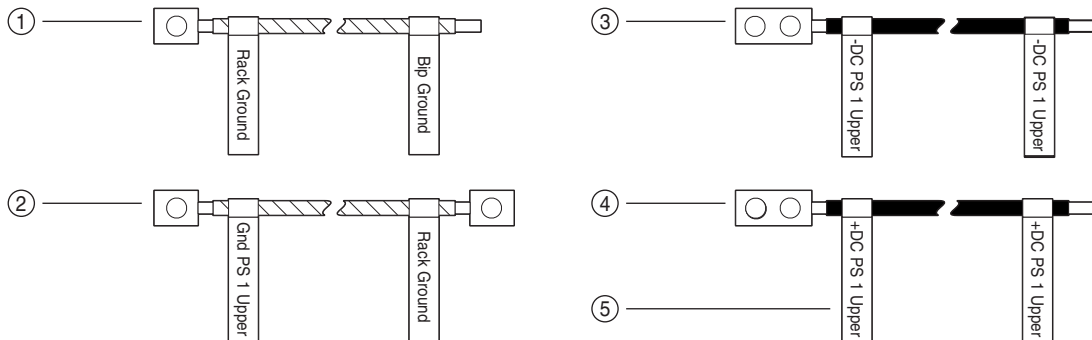

1 = BIP ground cable (x 1)

2 = Power supply ground cable (x 6)

3 = Power supply negative lead cable (x 6)

4 = Power supply positive lead cable (x 6)

5 = Label tags (optional, use as required)

10411EB

- 2 Use tie-wraps or cable ties to loosely bundle the cable leads for each power supply into a single manageable cable.
- 3 Route the bundled cables under each chassis to the back of the rack.
- 4 Separate the green (with yellow stripe) ground cable leads from the bundled cables, and route them to the base of the rack.

- 5 Route the remaining (black) power supply cables from the back of the lower and upper shelf chassis to the back panel of the BIP, loosely fastening them with tie-wraps along the path.
- 6 Loosely support the power supply cables with tie-wraps above the BIP power terminal block.
- 7 Proceed to, [“Connecting the ground cables to the rack grounding strip.”](#)

## Connecting the ground cables to the rack grounding strip

To connect the power supply ground cables to the rack grounding strip:

- 1 Locate the rack grounding strip at the back base of the rack ([Figure 31](#)).



**Note:** [Figure 31](#) shows an example of a rack grounding strip. Your rack grounding strip can look different than the one shown in this example.

- 2 Attach the lug ends of the power supply ground cables to the rack grounding strip ([Figure 31](#)).

Use a 7/16-inch hex wrench to fasten the hardware in the correct order.

**Figure 31** Rack grounding strip example

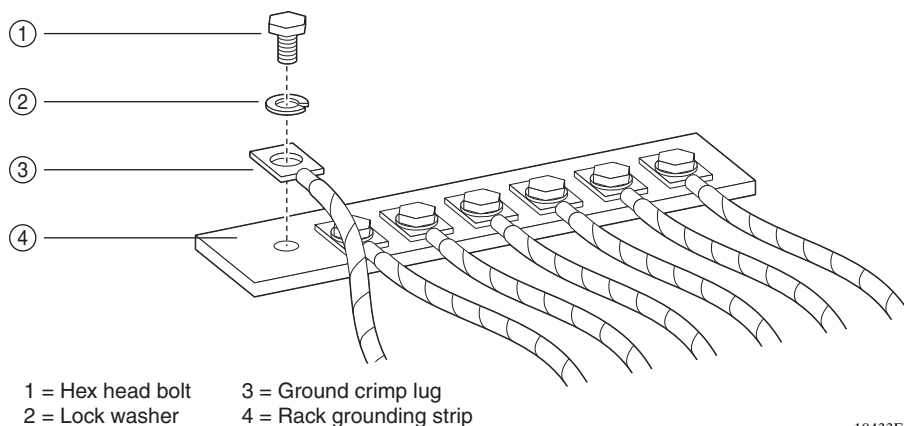

10433FA

- 3 Proceed to [“Connecting the power supply cables to the BIP”](#) on page 49.



## Connecting the power supply cables to the BIP

To connect the power supply cables to the BIP:

- 1 Locate one of the power supply cables.
- 2 Match the labeled tag on the power supply cable with the correct location on the power terminal block (Figure 32).

The power terminal block label indicates a location for the positive and negative power supply leads for both the upper shelf and lower shelf power supplies.

- 3 Loosen the appropriate power terminal block screw, and then insert the cable lead (item 1 in Figure 32). Tighten the screw securely.

Item 2 in Figure 32 shows the negative cable lead from power supply 1 in the upper shelf correctly connected to the power terminal block.

**Figure 32** Attaching power supply cable leads to the BIP

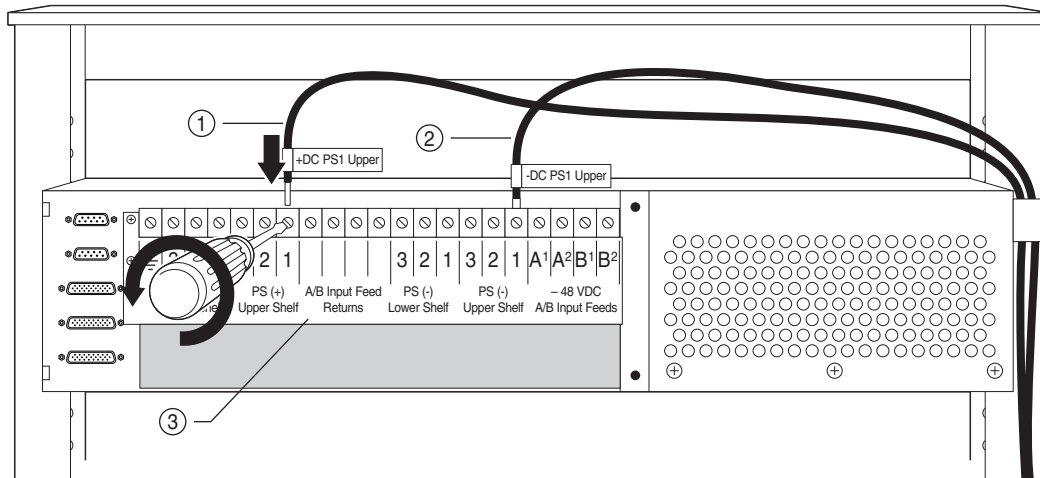

1 = Positive lead wire from power supply 1, upper shelf  
2 = Negative lead wire from power supply 1, upper shelf

3 = Power terminal block label

10393FA

- 4 Repeat steps 1 through 3 for each remaining power supply in your configuration (Figure 33).

**Figure 33** Upper and lower shelf power cables connected to the BIP

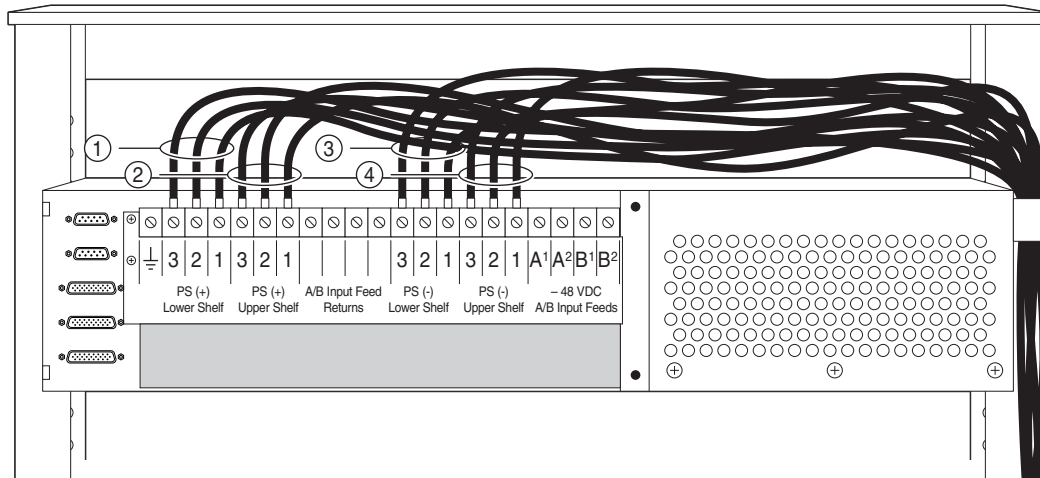

- |   |   |
|---|---|
| 1 = Positive lead wires<br>(lower shelf power supplies) | 3 = Negative lead wires<br>(lower shelf power supplies) |
| 2 = Positive lead wires<br>(upper shelf power supplies) | 4 = Negative lead wires<br>(upper shelf power supplies) |

10394FA

- 5 Locate the BIP ground cable (see Figure 30 on page 47).

- 6 Attach one end of the BIP ground cable to the power terminal block (Figure 34).
  - a Loosen the power terminal block screw just enough to insert the ground cable lead (item 1 in Figure 34).
  - b Insert the lead and tighten the screw securely.

**Figure 34** Attaching the BIP ground cable

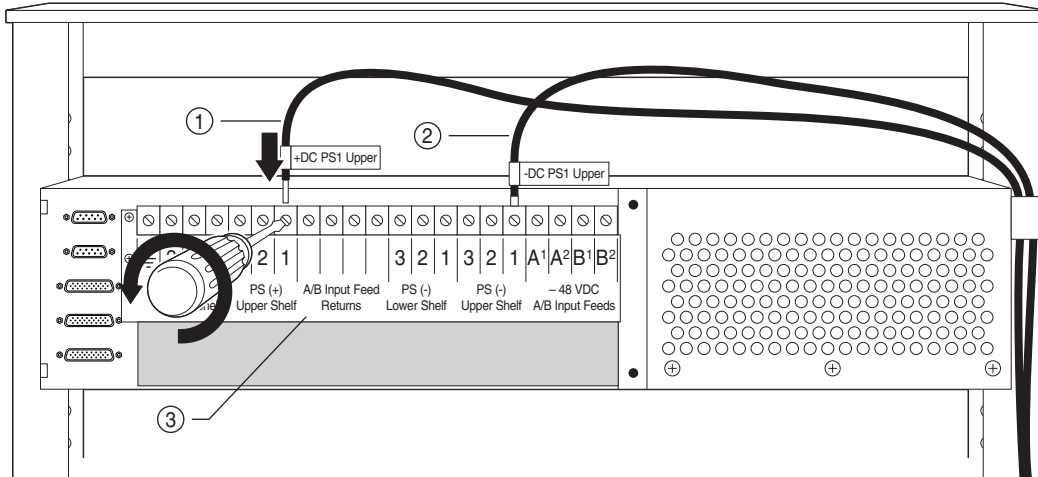

1 = Positive lead wire from power supply 1, upper shelf

3 = Power terminal block label

- 7 Route the other end of the BIP ground cable to the rack grounding strip near the base of the rack (see Figure 31 on page 48).  
Use a 7/16-inch hex wrench to fasten the hardware in the correct order.
- 8 Go to the next section, “Connecting DC input power feeds to the BIP” on page 52.

## Connecting DC input power feeds to the BIP



**Danger:** Due to high-energy hazards, only qualified service personnel are permitted to connect the BIP to the DC power source.

---



**Warning:** Ensure that the DC power source is off or disconnected on the remote end before you perform any of the steps in this section. You may need to switch a circuit breaker off or turn off power at the DC input source.

---

Nortel does not supply the cables for connecting the breaker interface panel to the DC input power source. You must select cables that comply with the electrical code of the country where you intend to use the DC-DC power supply.



**Caution:** As the installer, you have the sole responsibility for ensuring that the connection cable used with the breaker interface panel is appropriate for use with the DC power source to which the power supply is connected. Consider gauge, flammability, and mechanical serviceability when determining which cables to use.

---

You can connect up to two “A” feeds and two “B” feeds to your 8010co chassis configuration for redundancy. Each chassis can require up to 60 A service for maximum operating power.

As shown in [Figure 35 on page 53](#), the primary B feed (B<sup>1</sup>) provides redundancy for the primary A feed (A<sup>1</sup>), and the secondary B feed (B<sup>2</sup>) provides redundancy for the secondary A feed (A<sup>2</sup>).



**Note:** An *optional* third power supply in the chassis provides redundancy and high-availability operation. In the same way, the BIP provides redundancy and high-availability operation by allowing two additional “B” feeds to provide redundancy for single or dual chassis installations.

---

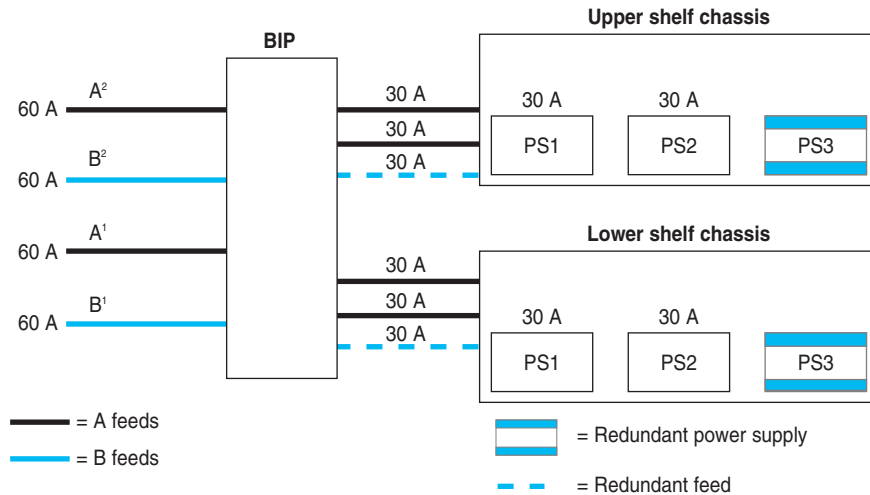
**Figure 35** A and B feed example

10400EC

Table 3 lists input power options for single and dual chassis installations.

**Table 3** Single chassis and dual chassis input options

	Single chassis input*	Dual chassis input
Non-redundant input power	A <sup>1</sup>	A <sup>1</sup> and A <sup>2</sup>
Redundant input power	A <sup>1</sup> and B <sup>1</sup>	A <sup>1</sup> and B <sup>1</sup> , A <sup>2</sup> and B <sup>2</sup>

\* For a single chassis installation, always install the chassis in the lower shelf position to stabilize the rack.

To connect the DC input feeds to the BIP:

- 1 Locate the DC power source for the DC input feed.



**Warning:** Ensure that the DC power source is off or disconnected on the remote end before you perform any of the steps in this section. You may need to switch a circuit breaker off or turn off power at the DC input source.

- 2 Determine the power requirements for your configuration (see [Figure 35 on page 53](#)).
- 3 Locate the A and B -48 VDC input feeds ([Figure 36](#)).



**Note:** [Figure 36](#) shows an example of a site DC input conduit. Your DC input conduit can look different or can be in a different location than the one shown in the following examples.

The -48 VDC input feed cables should be tagged with source labels (for example, -48 VDC Input feed or -48 VDC Return). If they are not labeled, and you are not sure of the source, ask for assistance from a qualified electrician.

**Figure 36** Locating the A and B -48 VDC input feeds

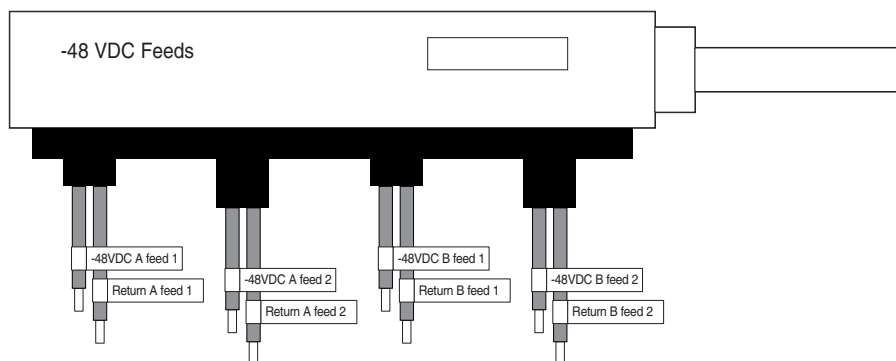

10401EA

- 4 Connect the -48 VDC input feeds according to your configuration requirements.
  - a Match the tagged -48 VDC input feed cable lead with the correct power terminal block on the back of the BIP (Figure 37).
  - a Loosen the power terminal block screw just enough to insert the cable lead (item 1 in Figure 37).
  - b Insert the lead and tighten the screw securely.

**Figure 37** Connecting the A and B -48 VDC input feeds to the BIP (1 of 2)

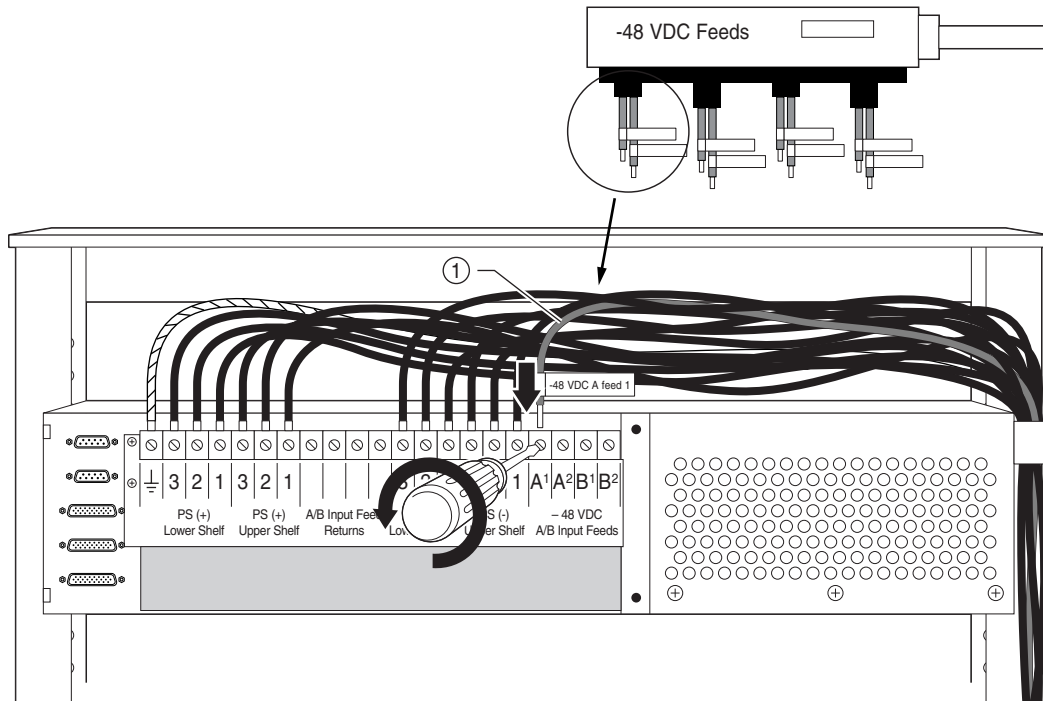

1 = -48 VDC input feed (Primary A feed)

10406FA

- 5 Connect the remaining -48 VDC input feeds and returns as required (Figure 38).



**Note:** Figure 38 shows the attachment of two “A” feeds and two “B” feeds to the BIP. Note that there is a primary and a secondary A feed, as well as a primary and secondary B feed (see Figure 35 on page 53 for configuration details).

**Figure 38** Connecting the A and B -48 VDC input feeds to the BIP (2 of 2)

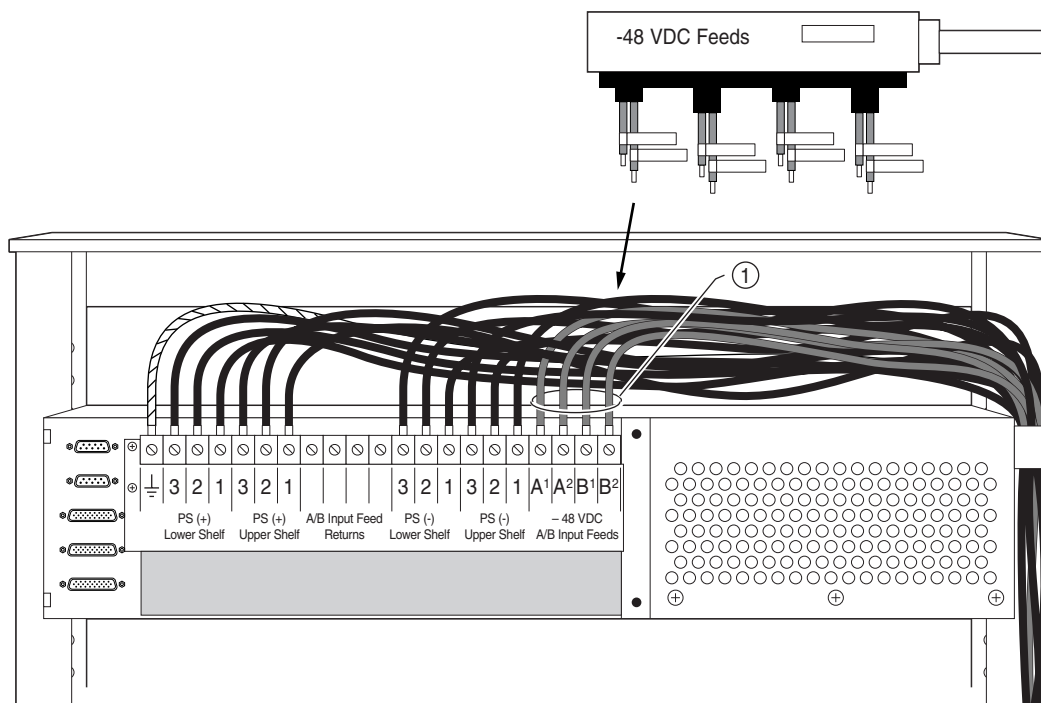

1 = -48 VDC input feeds (Primary A, Secondary A, Primary B, Secondary B)

10407FA



## 6 Connect the A/B input feed returns.



**Note:** The total number (quantity) of Input feed return cable leads must match the total number of Input feeds used for your installation.

- a Locate the A/B Input Feed Returns section of the power terminal block.
- b Loosen one of the four available A/B input feed return connection screws just enough to insert the cable lead (item 1 in Figure 39).

You can use any of the four available input feed return connections.

- c Insert the lead and tighten the screw securely.

**Figure 39** Connecting the A/B input feed returns (1 of 2)

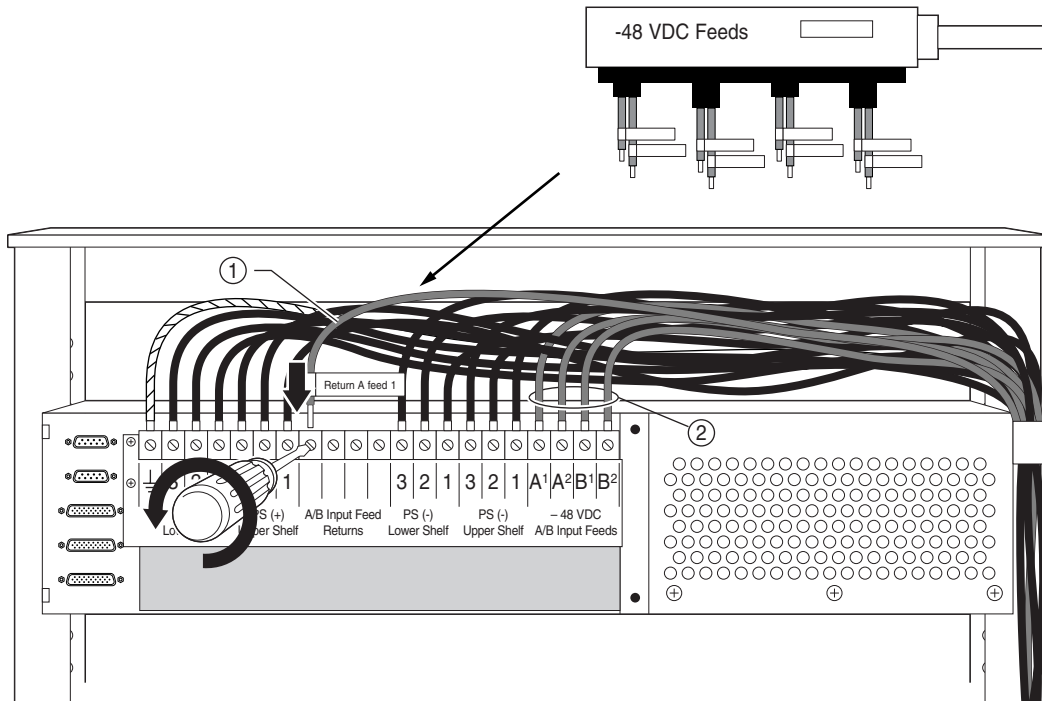

1 = -48 VDC input feed Return (Primary A feed Return)

2 = -48 VDC input feeds (Primary A, Secondary A, Primary B, Secondary B)

10408FA

- 7 Connect the remaining -48 VDC input returns as required ([Figure 40](#)).

[Figure 40](#) shows the BIP with all power cables and returns installed.



**Note:** Be sure to properly support the cables with cable ties to avoid undue stress to the power terminal block.

**Figure 40** Connecting the A/B input feed returns (2 of 2)

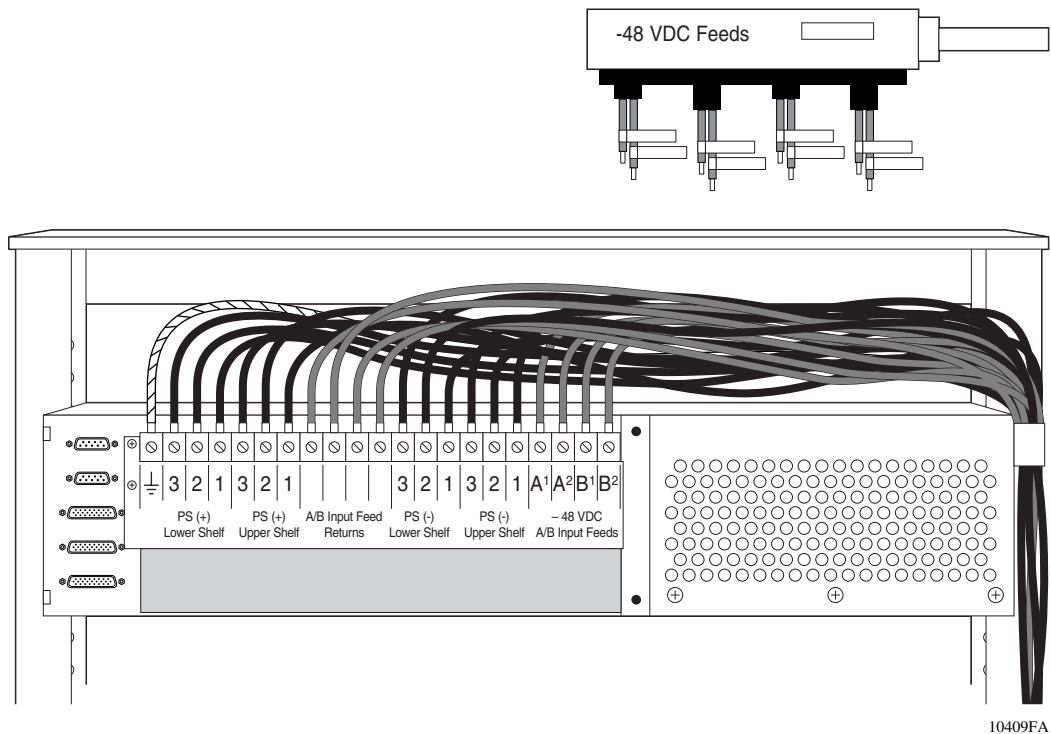

- 8 Go to the next section, [“Replacing covers”](#) on page 59.

## Replacing covers

After you complete all of the cabling requirements as described in the previous sections, you must replace the plastic back cover on the BIP and the 8010co chassis bezel(s) that were removed earlier in these procedures.

Before you replace the covers and bezels, be sure that all cables are routed properly from under the chassis bays, through the rack, and up to the BIP power terminal block. Check that all tie-wraps are secured, and give special attention to the cables at the power terminal strip; the cable leads must be supported to avoid undue stress on the terminal block.

- 1 Replace the plastic back cover on the BIP (Figure 41).

**Figure 41** Replacing the plastic back cover on the BIP

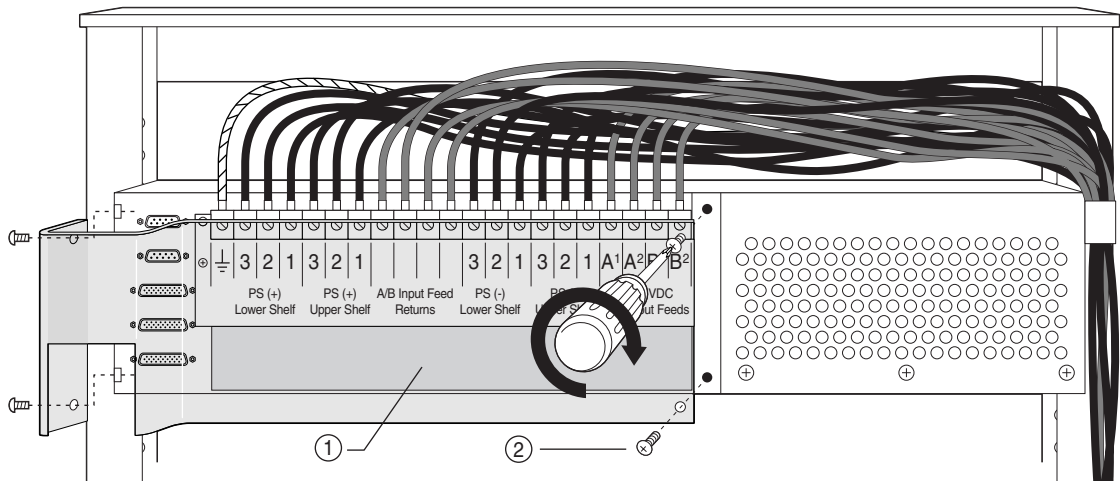

- 1 = Back cover (plastic)  
2 = Cover screws (x 4)

10410FA

- 2 Replace the 8010co chassis bezel.
  - a Set the notch (on both ends of the 312096-A bezel) into the tabs on the chassis (Figure 42).
  - b Lift the top of the bezel up, and then align the captive screws with the holes in the chassis.
  - c Using a Phillips screwdriver, tighten the 2 captive screws to secure the bezel to the chassis.
  - d Replace the bezel on the second chassis, if installed.

**Figure 42** Replacing the 8010co chassis 312096-A bezel

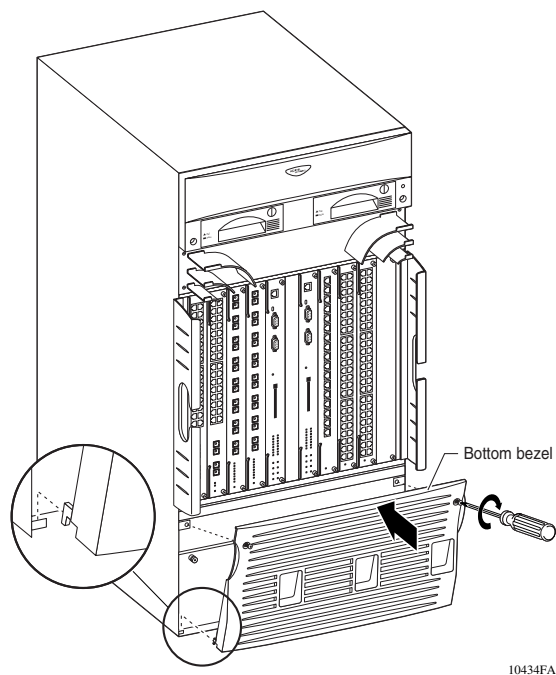

- 3 Go to the next section, [“Installing shelf alarm cables”](#) on page 61.

## Installing shelf alarm cables



**Note:** The BIP ships from the factory with default alarm configurations set for a single chassis in the lower shelf of the rack. If you install a second chassis, you must configure the jumpers on the alarm module to support that configuration. See [“Accessing the alarm module” on page 30](#) if you need to modify the shelf alarm jumpers.

- 1 To install the shelf alarm cable for a single chassis in the lower shelf:
  - a Locate the shelf alarm cables in the shipping container.
  - b Connect one end of the shelf alarm cable to the J2 connector on the back of the BIP (Figure 43).
  - c Connect the other end of the shelf alarm cable to the lower shelf chassis alarm connector, on the lower shelf chassis.

**Figure 43** Installing shelf alarm cables

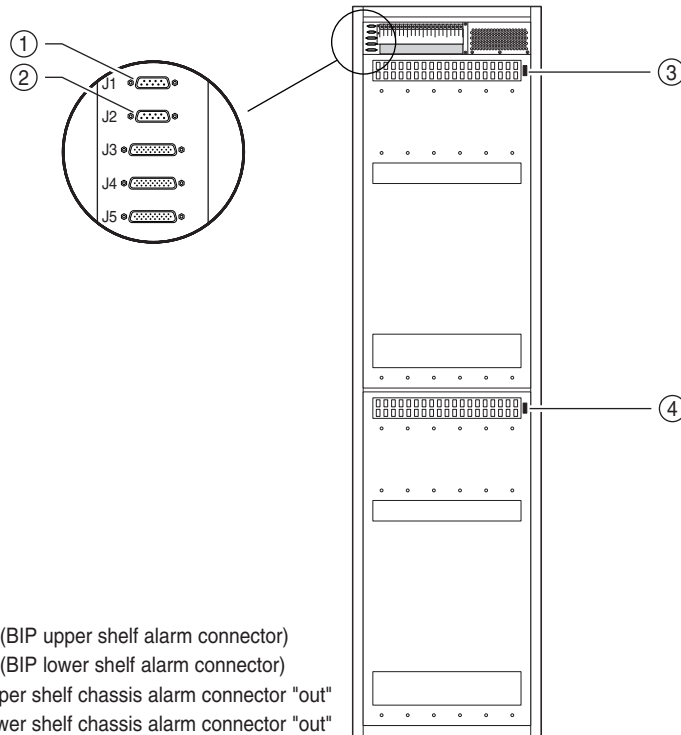

10380EA

- 2 To install the shelf alarm cable for a second chassis in the upper shelf:
  - a Configure the jumpers on the alarm module to support a second chassis in the upper shelf as described in [“Accessing the alarm module” on page 30](#).
  - b Connect one end of the shelf alarm cable to the J1 connector on the back of the BIP ([Figure 43](#)).
  - c Connect the other end of the shelf alarm cable to the upper shelf chassis alarm connector, on the upper shelf chassis.

After successfully installing the shelf alarm cables, go to the next section [“Verifying the installation.”](#)

## Verifying the installation

This section describes how to verify the BIP hardware installation. It includes the following topics:

- [“Initial power-up,”](#) next
- [“Verifying the LEDs” on page 63](#)
- [“Powering off the system” on page 64](#)

Before powering up the system to verify the installation, be sure that:

- All cables are installed and properly secured.
- All safety covers, filler panels, and bezels are installed and secure.
- All tools and installation materials are removed.
- You notify others working in the area that the system power is about to be turned on.

---

## Initial power-up



**Danger:** Due to high-energy hazards, only qualified service personnel are permitted to connect the BIP to the DC power source.

---

To power up the 8010co chassis:

- 1 Set the six circuit breakers on the BIP front panel to the off position (O = Off).
- 2 Set the switches for all power supplies in the upper and lower chassis to the off position (O = Off).  
You can access the power supply switches with the bezels installed.
- 3 Turn on the input feed power at the DC power source.

## Verifying the LEDs

- 1 Verify the following LEDs on the BIP:
  - The (white) POWER Indicator on the BIP front panel is on.
  - The (green) shelf alarm cable validation LED is on steady.  
The green shelf alarm cable validation LED indicates that the shelf alarm cables are installed properly.  
(If there is a problem with the shelf alarm cable installation or jumper settings, the red shelf alarm cable *fault* LED turns on.)
- 2 Set the six circuit breakers on the BIP front panel to the on position (I = On).
- 3 Set the switches for all power supplies in the upper and lower chassis to the on position (I = On).



**Note:** When you first install a 8010co chassis that contains two or three power supplies, you must turn on two of the power supply units simultaneously. If you wait longer to turn on the second power supply, one of the power supplies can shut down. To correct this condition, turn off both power supplies, wait at least 30 seconds, and then turn on both power supplies again simultaneously.

---

- 4 Verify the following LEDs on the 8010co chassis:
  - The (green) power supply LEDs for each power supply in both the upper and lower chassis are on.  
(If any of the power supply LEDs are not on, replace the power supply.)
  - The chassis fans are powering up.

If any of the previous steps indicate a problem with the installation, do the following:

- 1 Set the switches for all power supplies in the upper and lower chassis to the off position (O = Off).
- 2 Set the six circuit breakers on the BIP front panel to the off position (O = Off).
- 3 Check that all cables are installed properly, and that all power supplies are firmly seated in their bays.
- 4 Set the six circuit breakers on the BIP front panel to the on position (I = On).
- 5 Set the switches for all power supplies in the upper and lower chassis to the on position (I = On).
- 6 Proceed to [“Verifying the LEDs” on page 63](#).

If the problem persists, go to [Chapter 3, “Problem solving,” on page 67](#).

## Powering off the system

To power off the system:

- 1 Set the switches for all power supplies in the upper and lower chassis to the off position (O = Off).  
You can access the power supply switches with the bezels installed.
- 2 Set the six circuit breakers on the BIP front panel to the off position (O = Off).
- 3 Turn off the input feed power at the DC power source.



**Warning:** Ensure the DC power source is off or disconnected. You may need to switch a circuit breaker off or turn off power at the DC input source. Be sure that the DC input source power is locked out and tagged.

---





**Note:** When you power off the 8010co chassis, wait at least 30 seconds before turning the power supplies back on.

---

- 4 Continue with the installation of the 8010co chassis as described in the appropriate product chassis installation manual.



---

## Chapter 3

# Problem solving

---

This chapter describes how to isolate and diagnose problems with your breaker interface panel and associated 8010co chassis.

This chapter covers the following topics:

- [“Interpreting the LEDs”](#) (next)
- [“Diagnosing and correcting the problem”](#) on page 70
- [“Corrective actions”](#) on page 71

The topics lead you through a logical process for troubleshooting the BIP and the associated 8010co chassis components. The BIP LEDs provide visual indications of problems that can occur with the 8010co chassis and installed components, as well as system status during normal operations.

To become familiar with the various states that the LEDs can exhibit during normal operation, go to the next section, [“Interpreting the LEDs”](#) on page 68.

For help in determining a problem, go to [“Diagnosing and correcting the problem”](#) on page 70. That section describes symptoms and corrective actions you can perform to resolve specific problems.

If the corrective actions determine that a chassis component needs replacing, see the appropriate product chassis installation manual for replacement and removal procedures.

If you still have problems with your system after completing the instructions in this chapter, contact the Nortel Technical Solutions Center.

# Interpreting the LEDs

All BIP LEDs and indicators are located on the front panel (Figure 44).

**Figure 44** BIP LEDs and indicators

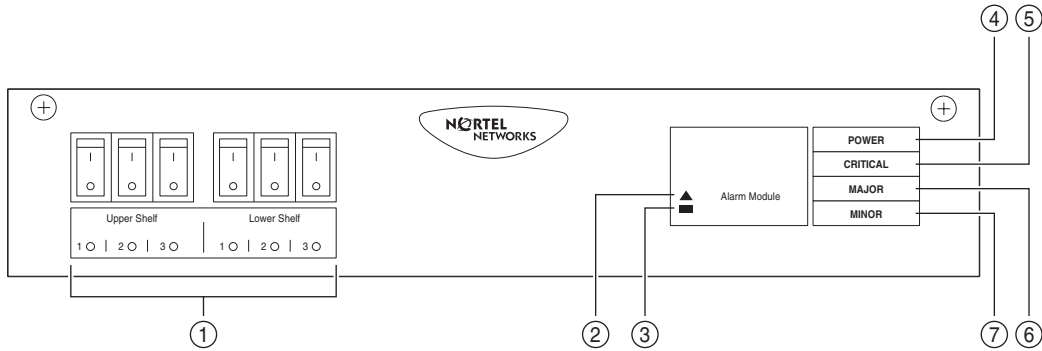

- 1 = Shelf circuit breakers LEDs
- 2 = Shelf alarm cable fault LED
- 3 = Shelf alarm cable validation LED
- 4 = POWER indicator
- 5 = CRITICAL fault indicator
- 6 = MAJOR fault indicator
- 7 = MINOR fault indicator

10435EB

Table 4 describes the BIP LEDs and indicators.

**Table 4** BIP LEDs and indicators

Item	Label/Icon	Type	Color/State	Description
1	Upper Shelf/ Lower Shelf	LED	Red/On steady	Circuit breaker LEDs (for upper shelf and lower shelf power supplies)—Indicates that a circuit breaker has tripped due to an overcurrent condition with the associated power supply. This fault condition also lights the (red) MAJOR fault indicator (see MAJOR fault description in this table). No alarm is generated when a shelf circuit breaker is manually switched on (I) or off (O).
2	▲	LED	Red/On steady	Shelf alarm cable fault LED—The shelf alarm cables are missing, not secured, or the shelf alarm jumpers are not configured properly (see <a href="#">“Accessing the alarm module” on page 30</a> ). This fault condition also lights the MINOR fault indicator (see Minor fault description in this table).
3	■	LED	Green/On steady	Shelf alarm cable validation LED —The shelf alarm cables are properly connected to the shelves.

**Table 4** BIP LEDs and indicators (continued)

Item	Label/Icon	Type	Color/State	Description
4	POWER	Indicator	White/On steady	Power indicator—The external DC power is available to the BIP.
5	CRITICAL	Indicator	Red/On steady	Critical fault indicator—Indicates that a severe service-affecting condition has occurred that requires immediate corrective action. Common causes for this type of fault condition include: <ul style="list-style-type: none"> <li>• Line card failure</li> <li>• Temperature fault</li> <li>• CPU fault when only one CPU is installed</li> </ul>
6	MAJOR	Indicator	Red/On steady	Major fault indicator—Indicates that the system hardware or software has identified a serious disruption of service or that an important circuit failure has occurred. <p>Common causes for this type of fault condition include:</p> <ul style="list-style-type: none"> <li>• CPU fault when two CPUs are installed</li> <li>• Two fan trays are faulty</li> <li>• A power supply circuit breaker has tripped due to an overcurrent condition</li> <li>• Two power supplies are faulty</li> </ul>
7	MINOR	Indicator	Yellow/On steady	Minor fault indicator —Indicates a problem that does not have a serious effect on customer service, or a problem in circuits that are not essential to device operation. <p>Common causes for this type of fault condition include:</p> <ul style="list-style-type: none"> <li>• Shelf alarm cables not installed or not connected properly.</li> <li>• Alarm module jumpers configured incorrectly.</li> <li>• One power supply is faulty</li> <li>• One fan tray is faulty</li> </ul>

If you need more help, go to the next section, [“Diagnosing and correcting the problem” on page 70](#).

## Diagnosing and correcting the problem

Before you perform the problem-solving steps in this section, complete the following steps:

- 1** Set the switches for all power supplies in the upper and lower chassis to the off position (O = Off).
- 2** Set the six circuit breakers on the BIP front panel to the off position (O = Off).
- 3** Check that all cables are installed properly, and that all power supplies are firmly seated in their bays.
- 4** Set the six circuit breakers on the BIP front panel to the on position (I = On).
- 5** Set the switches for all power supplies in the upper and lower chassis to the on position (I = On).
- 6** Verify the following LEDs on the BIP:
  - The (white) POWER Indicator on the BIP front-panel is on.
  - The (green) shelf alarm cable validation LED is on steady.
- 7** Verify the following LEDs on the 8010co chassis:
  - The (green) power supply LEDs for each power supply in both the upper and lower chassis are on.
  - The chassis fans are powering up.
- 8** If the problem still persists, go to the next section, [“Corrective actions” on page 71](#).

## Corrective actions

To resolve problems with the BIP or the 8010co chassis and components, follow the corrective actions suggested in [Table 5](#).

**Table 5** Corrective actions

Symptom	Probable cause	Corrective action
The (red) shelf alarm cable fault LED on the BIP front panel is on, and the (yellow) MINOR indicator is on steady.	Shelf alarm cables are not installed or installed incorrectly.	Check to see that the shelf alarm cables are secure and installed correctly, see <a href="#">“Installing shelf alarm cables” on page 61.</a> ”
	Shelf alarm jumpers not configured or configured incorrectly.	Check the shelf alarm jumper settings, see <a href="#">“Accessing the alarm module” on page 30.</a> ”
The (yellow) MINOR indicator is on steady.	A single chassis fan tray is faulty.	Locate and replace the faulty chassis tray, see the appropriate product chassis installation manual.
	A single power supply is faulty.	Locate and replace the faulty power supply, see the appropriate product chassis installation manual.
The (red) MAJOR indicator is on steady.	Two chassis fan trays are faulty.	Locate and replace the faulty chassis trays. See the appropriate product chassis installation manual, for replacement and removal of system components.
	Two power supplies are faulty.	Locate and replace the faulty power supplies. See the appropriate product chassis installation manual, for replacement and removal of system components.
	An overcurrent condition has occurred with one or more power supplies.	This fault condition causes the associated circuit breaker(s) on the BIP front panel to trip, and also lights the circuit breaker LED. Locate and replace the faulty power supplies. See the appropriate product chassis installation manual, for replacement and removal of system components.
	The master CPU has failed and the second (redundant) CPU has taken over system operations.	Locate and replace the faulty CPU. See the appropriate product chassis installation manual, for replacement and removal of system components.

**Table 5** Corrective actions (continued)

<b>Symptom</b>	<b>Probable cause</b>	<b>Corrective action</b>
The (red) CRITICAL indicator is on steady.	Failover from Master CPU to the second (redundant) CPU. This action is preceded by the CRITICAL indicator blinking two times and then turning off after the redundant CPU becomes operational.	After the Redundant CPU becomes operational, the (red) MAJOR indicator lights to indicate loss of the master CPU (see previous symptom).
	The maximum CPU operating temperature, 50°C (122°F), has been exceeded.	Check to see that nothing is blocking the air flow to the CPU; if airflow is present, power down the system and replace the CPU. See the appropriate product chassis installation manual, for replacement and removal of system components.
	The CPU subsystem has detected a fault.	Locate and remove the faulty card. See the appropriate product chassis installation manual, for replacement and removal of system components.
	A line card is booting and is not yet operational.	Wait until the line card finishes booting; the fault indicator goes out when booting is complete.
	A line card has failed.	Locate and hot swap the faulty line card. See the appropriate product chassis installation manual, for replacement and removal of system components.
A circuit breaker LED on the BIP front panel is on (red). The associated circuit breaker is tripped (off), and the (red) MAJOR indicator is on steady.	A circuit breaker has tripped due to an overcurrent condition with the associated power supply.	Locate and replace the faulty power supply. See the appropriate product chassis installation manual, for replacement and removal of system components.



---

## Appendix A

# Technical specifications

---

This appendix lists the technical specifications for the breaker interface panel.

This appendix covers the following topics:

- [“Environmental”](#) (next)
- [“Electrical”](#) on page 74
- [“Physical dimensions”](#) on page 74
- [“Electromagnetic emissions”](#) on page 74
- [“Safety agency certification”](#) on page 74

## Environmental

Parameter	Operating Specification	Storage Specification
Temperature	-5° to 55°C (23° to 131°F)	-50° to 70°C (-58° to 158°F)
Humidity	85% maximum relative humidity, noncondensing	85% maximum relative humidity, noncondensing
Altitude	1800 m (5,940 ft)	1800 m (5,940 ft)

## Electrical

---

Parameter	Specifications
Input Voltage (Nominal)	-48 VDC
Input Current Feed Rating	60 A per DC input feed
Output Current Feed Rating	30 A per DC output feed

---

## Physical dimensions

---

Parameter	Specifications
Height	12.6 cm (4.92 in.)
Width	50 cm (19.5 in.)
Depth	39.0 cm (15.2 in.)
Weight	15.4 kg (33.9 lb)

---

## Electromagnetic emissions

- Bellcore GR-1089-CORE
- EN50082 (CISPR 22)
- ETSI 300 386-2

## Safety agency certification

- UL Listed (UL 1950)
- Bellcore GR-1089-CORE
- CSA C22.2 No. 950
- EN 60950 and EN 41003

---

## Appendix B

# BIP external cable pin assignments

---

This appendix describes the breaker interface panel connectors.

This appendix covers the following topics:

- “Shelf alarm connectors (J1 and J2),” next
- “Office alarm connectors (J3 and J4)” on page 77
- “Standalone office alarm connector (J5)” on page 79

## Shelf alarm connectors (J1 and J2)

The BIP shelf alarm connectors (J1 and J2) use standard 9-pin D-sub connectors (Figure 45).

**Figure 45** J1 and J2 9-pin standard D-sub connector

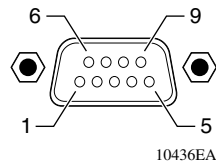

Figure 46 on page 76 shows the pinouts for the J1 and J2 shelf alarm connectors.

**Figure 46** J1 and J2 shelf alarm connector pinouts

Table 6 lists the pin assignments for the J1 and J2 shelf alarm connectors.

**Table 6** J1 and J2 shelf alarm connector pin assignments

Pin	Signal	Description
1	L+ABS	Alarm battery supply return.
2	VCRIT	Visual critical alarm.
3	ACRIT	Audible critical alarm.
4	DISCOUT	Indicates presence of shelf alarm cable.
5	DISCIN	Indicates presence of shelf alarm cable.
6	VMAJ	Visual major alarm.
7	VMIN	Visual minor alarm.
8	AMAJ	Audible major alarm.
9	AMIN	Audible minor alarm

## Office alarm connectors (J3 and J4)

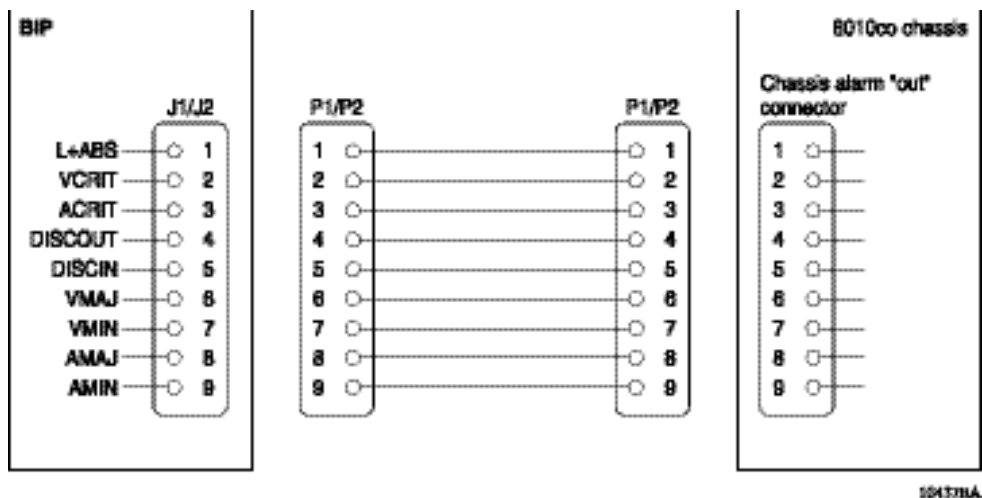
The BIP office alarm connectors (J3 and J4) use high-density, 26-pin D-sub connectors (Figure 47).

**Figure 47** J3 and J4 high-density 26-pin D-sub connector

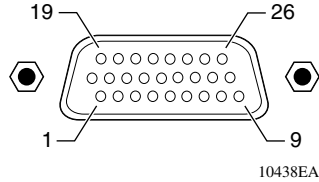

Figure 48 shows the pinouts for the J3 and J4 office alarm connectors.

**Figure 48** J3 and J4 office alarm connectors

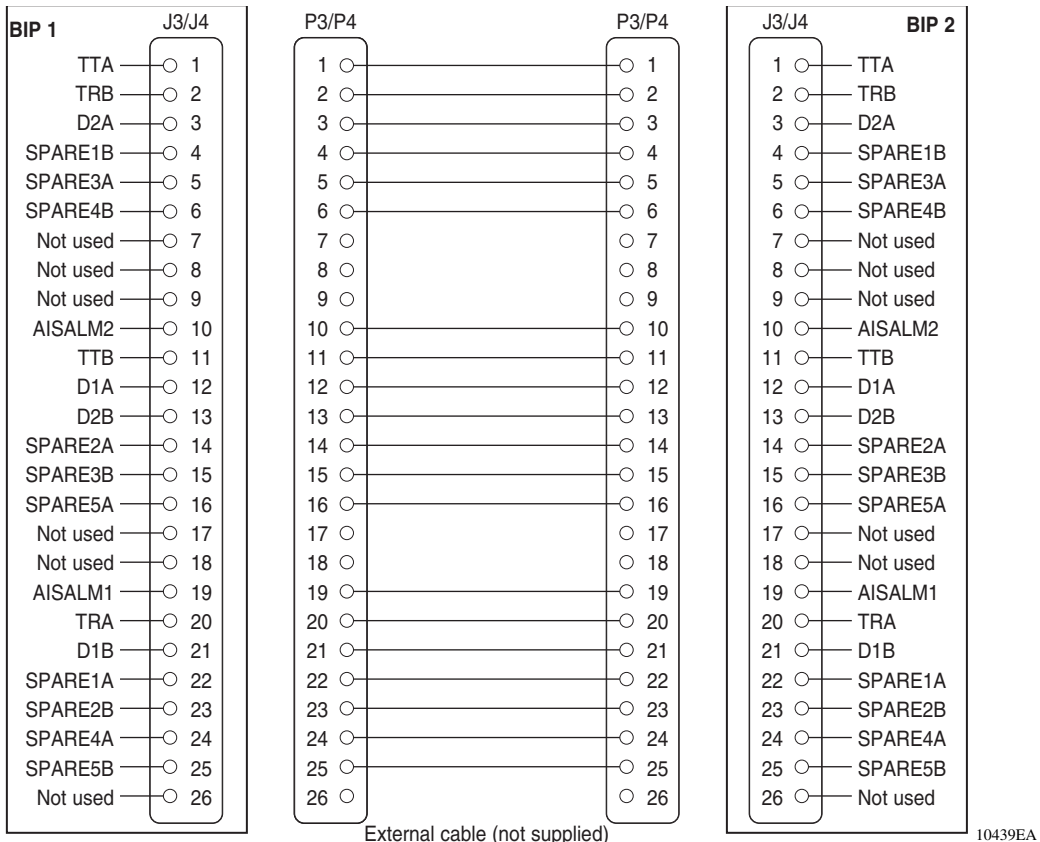

Table 7 lists the pin assignments for the J3 and J4 office alarm connectors.

**Table 7** J3 and J4 office alarm connector pin assignments

Pin	Signal	Description
1	TTA	Voice communications from telephone jacks.
2	TRB	Voice communications from telephone jacks.
3	D2A	Data communications from Data jacks.
4	SPARE1B	Signal provided for office alarm connectivity.
5	SPARE3A	Signal provided for office alarm connectivity.
6	SPARE4B	Signal provided for office alarm connectivity.
10	AISALM2	Normally open from relay. Switches to AISALM1 on aisle alarm (Followme) activation.
11	TTB	Voice communication from telephone jacks.
12	D1A	Data communication from DATA jacks.
13	D2B	Data communication from DATA jacks.
14	SPARE2A	Signal provided for office alarm connectivity.
15	SPARE3B	Signal provided for office alarm connectivity.
16	SPARE5A	Signal provided for office alarm connectivity.
19	AISALM1	Tied to BR externally at office alarm cross connect panel.
20	TRA	Voice communication from telephone jacks.
21	D1B	Data communication from DATA jacks.
22	SPARE1A	Signal provided for office alarm connectivity.
23	SPARE2B	Signal provided for office alarm connectivity.
24	SPARE4A	Signal provided for office alarm connectivity.
25	SPARE5B	Signal provided for office alarm connectivity.

## Standalone office alarm connector (J5)

The standalone office alarm connectors (J5) uses a high-density, 26-pin D-sub connector (Figure 49).

**Figure 49** J5 high-density 26-pin D-sub connector

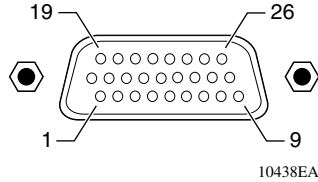

Figure 50 shows the pinouts for the J5 standalone office alarm connector.

**Figure 50** J5 standalone office alarm connector

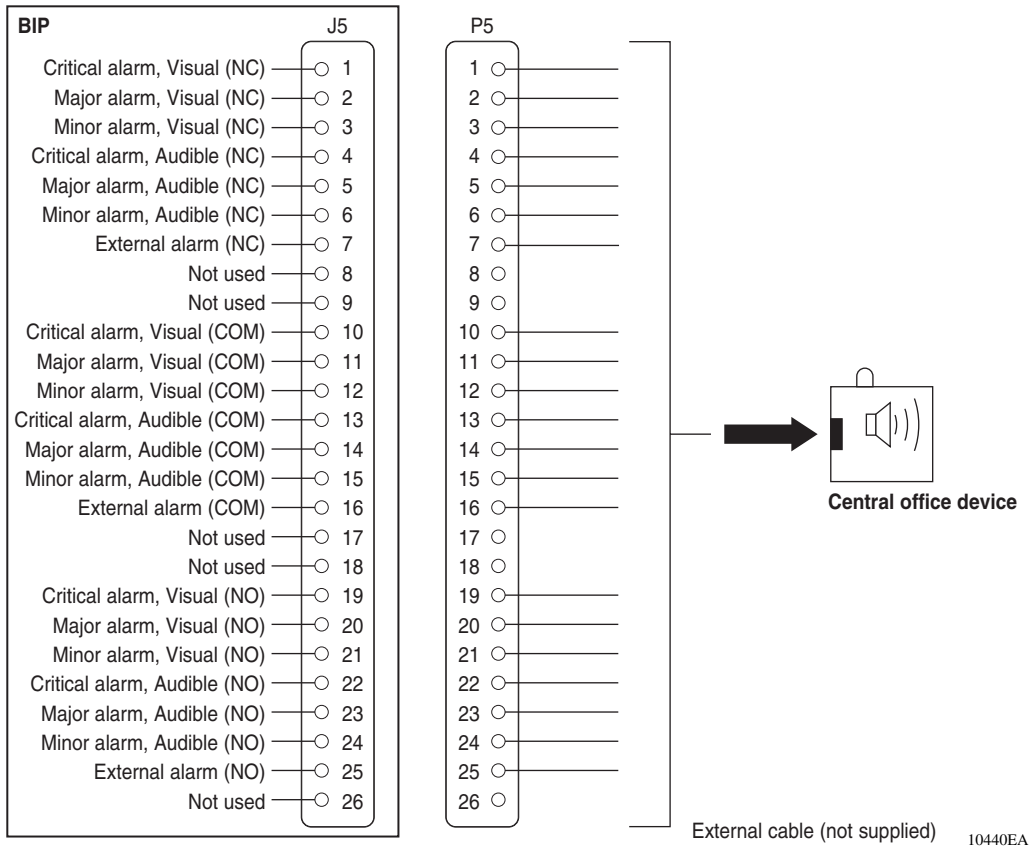

Table 8 lists the pin assignments for the J5 standalone office alarm connector.

**Table 8** J5 standalone office alarm connector pin assignments

Pin	Signal	Description
1	Critical alarm—Visual (NC)	Visual alarm contact
2	Major alarm—Visual (NC)	Visual alarm contact
3	Minor alarm—Visual (NC)	Visual alarm contact
4	Critical alarm—Audible (NC)	Audible alarm contact
5	Major alarm—Audible (NC)	Audible alarm contact
6	Minor alarm—Audible (NC)	Audible alarm contact
7	External alarm—(NC)	External alarm contact
10	Critical alarm—Visual (COM)	Visual alarm contact
11	Major alarm—Visual (COM)	Visual alarm contact
12	Minor alarm—Visual (COM)	Visual alarm contact
13	Critical alarm—Audible (COM)	Audible alarm contact
14	Major alarm—Audible (COM)	Audible alarm contact
15	Minor alarm—Audible (COM)	Audible alarm contact
16	External alarm—(COM)	External alarm contact
19	Critical alarm—Visual (NO)	Visual alarm contact
20	Major alarm—Visual (NO)	Visual alarm contact
21	Minor alarm—Visual (NO)	Visual alarm contact
22	Critical alarm—Audible (NO)	Audible alarm contact
23	Major alarm—Audible (NO)	Audible alarm contact
24	Minor alarm—Audible (NO)	Audible alarm contact
25	External alarm—(NO)	External alarm contact



---

# Index

---

## Numbers

8691omSF central processing unit (CPU) 23

8691SF central processing unit (CPU) 23

## A

alarm module

alarm conditions 23

configuring jumpers 30

display panel 22

LEDs 22

alarms

aisle 26

central office 26

## B

back panel 24

breaker interface panel (BIP)

configuring multiple BIPs 26

configuring standalone BIPs 27

installing 33

physical description 19

technical specifications 73

## C

cables

BIP ground cable, connecting 51

chassis power supplies, connecting 38, 49

DC input power feeds, connecting 52

ground cables, connecting to rack 48

J1 and J2 shelf alarm cables 75

J3 and J4 office alarm cables 77

J5 standalone office alarm cable 79

pin assignments 75

power supply cables, routing 47

central office alarm connectors 26

circuit breakers 20, 72

conventions, text 16

## D

DC electrical requirements 35

## E

electrical requirements, DC 35

external cable pin assignments 75

## F

front panel

description 20

LEDs 68

## G

grounding requirements 36

## I

initial power-up 63

## J

jumpers, shelf alarm cables 30

## L

LEDs

- alarm module 22
- BIP front panel 68
- description 68
- location 68

## P

- pin assignments, cables 75
- power
  - DC input requirements 35
  - initial power-up 63
  - powering off the system 64
- power supplies
  - cable routing 47
  - connecting cables 38, 49
- power terminal block 28
- problem solving
  - corrective actions 71
  - interpreting LEDs 67

## R

- requirements
  - 8691omSF CPU 19, 23
  - 8691SF CPU 19, 23
  - cooling 36
  - DC 35
  - grounding 36
  - physical 33, 35

## S

- shelf alarm cables
  - installing 61
  - jumper default configurations 30
- shelf alarm connectors 25
- shipment contents 34

## T

- technical specifications 73
- text conventions 16
- troubleshooting 67

## V

- verifying the installation 62