

**READ AND SAVE THESE INSTRUCTIONS.**



**Marley**  
Engineered Products

**MODEL A24DD**

**DIRECT DRIVE  
WHOLE HOUSE VENTILATORS**

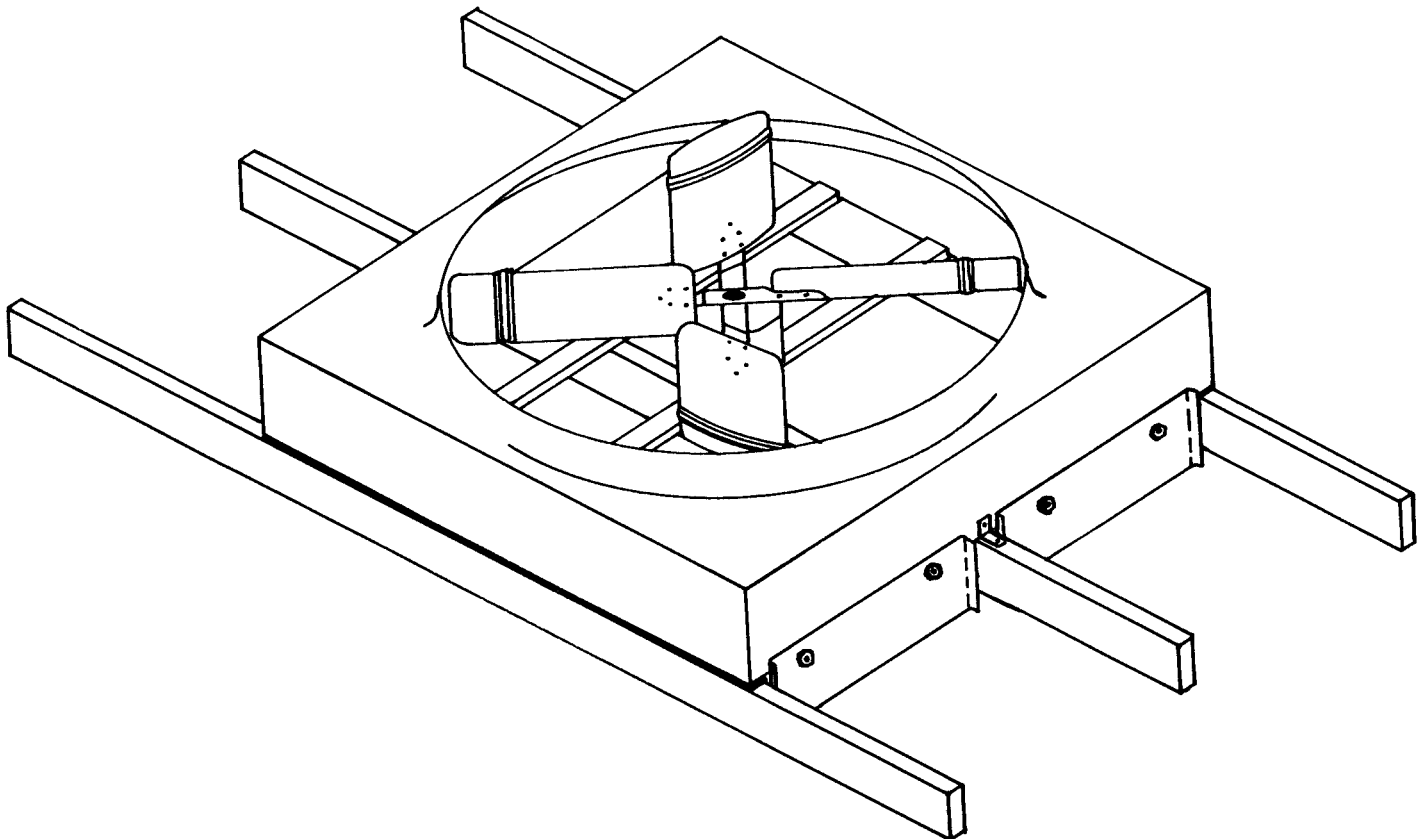

**LEAVE THIS MANUAL WITH HOMEOWNER**

---

---

# IMPORTANT SAFETY INSTRUCTIONS

---

---

## **WARNING:**

TO REDUCE THE RISK OF FIRE, ELECTRICAL SHOCK  
OR INJURY TO PERSONS, OBSERVE THE FOLLOWING:

1. Do not use this fan with any Solid-State Speed Control Device.
2. Use this unit only in the manner intended by the manufacturer. If you have questions, contact the manufacturer.
3. Before servicing or cleaning unit, switch power off at service panel and lock service panel to prevent power from being switched on accidentally.
4. Installation work and electrical wiring must be done by qualified person(s) in accordance with all applicable codes and standards, including fire-rated construction.
5. Sufficient air is needed for proper combustion and exhausting of gases through the flue (chimney) of fuel burning equipment to prevent back drafting. Follow the heating equipment manufacturer's guideline and safety standards such as those published by the National Fire Protection Association (NFPA), and the American Society for Heating Refrigeration and Air Conditioning Engineers (ASHRAE), and the local code authorities.
6. CAUTION: For general ventilation use only! Do not use to exhaust hazardous or explosive materials and vapors.
7. When cutting or drilling into wall or ceiling, Do Not damage electrical wiring or other hidden utilities.
8. CAUTION: This unit has an unguarded impeller. Do not use in locations readily accessible to people or animals.

## **INTRODUCTION**

Your Whole House Ventilator is designed and engineered to provide years of satisfactory service in cooling and ventilating your entire house. Hot, humid air is drawn from the living areas and replaced by cooler outside air. This cooler air may be routed through selected areas of the house by opening the proper windows and doors.

This Whole House Ventilator is a direct drive unit designed to provide maximum ventilation at minimum sound levels, and is supplied with a 3-speed control. It is specifically designed and engineered to eliminate cutting of 16" O.C. joists, thus providing the easiest installation available. The shutter is also designed to give an attractive flush appearance without cutting the center joist.

Shutter model required: Ceiling Installation — Model A3024  
Wall Installation — Model 3130

## CEILING INSTALLATION

### LOCATING & MOUNTING FAN

**STEP 1** — The A24DD fan mounts on ceiling joists that are spaced 16" O.C. Fan should be located in center of house, preferably in hallway or corridor. This will allow air to be drawn through all parts of living space. (See Fig. 1.) Determine tentative location of fan and proceed as shown below.

**STEP 2** — Determine joist direction and locate center joist in tentative fan opening. Lightly pencil a rectangular 30 1/2" x 33 1/2" opening on ceiling below where shutter is to be located. Make sure 33 1/2" side is parallel to joist direction. Check to be sure that enough clearance area is available on ceiling for overlap of shutter flanges (1 1/2" on all sides). Drill two small pilot holes close to center joist, (one on either side) to indicate where hole will be centered. (See Fig. 2.)

**STEP 3** — Now clear insulation and find pilot holes in attic. Tentatively lay out same rectangular hole as on ceiling below. Adjust location of hole if necessary to insure a minimum vertical clearance from roof rafters of 18" above fan (Fig. 3).

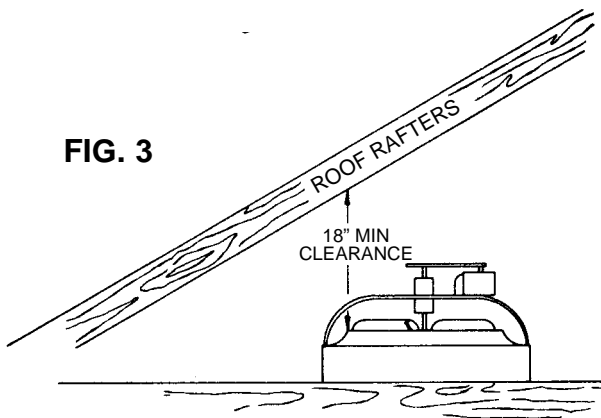

**STEP 4** — Carefully cut hole in ceiling (Fig. 4), being careful not to cut into center joist. Cut along both sides of the center joist, leaving the 1 1/2" (approximately) strip of ceiling sheet rock covering the center joist.

If you have 2 x 4 joist construction, the joists on which the fan will be mounted must be built up to 2 x 6 joist height. This can be done very easily at this point by nailing (3) 2 x 2 furring strips 38" long to the top of the joists, one on each joist.

**STEP 5** — Remove adhesive backing from the 1/2" x 1/2" gasket material and attach to the bottom flanges of fan which rest on the joists. (Fig. 5) Now place fan on joists. Install grommet in bracket (Fig. 5) and attach on each end of fan, using two of the short screws provided. Position fan over opening so that grommets are resting against center joist. Attach fan and brackets to center joist with the two long wood screws and flat washers. Do not crush grommet when tightening screws.

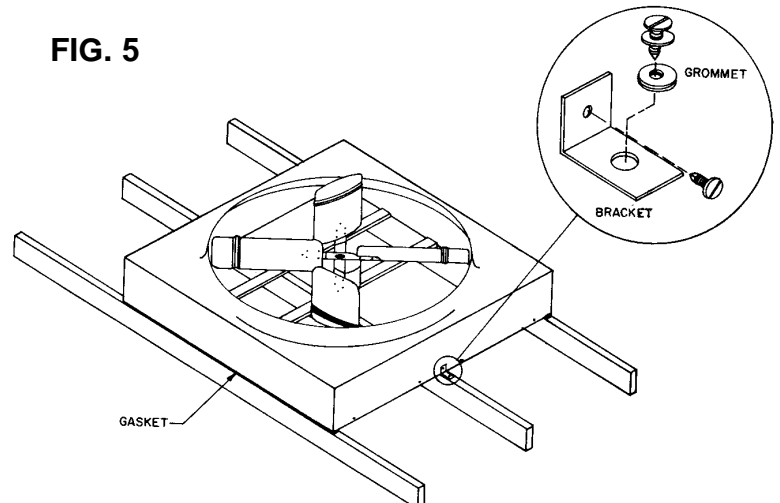
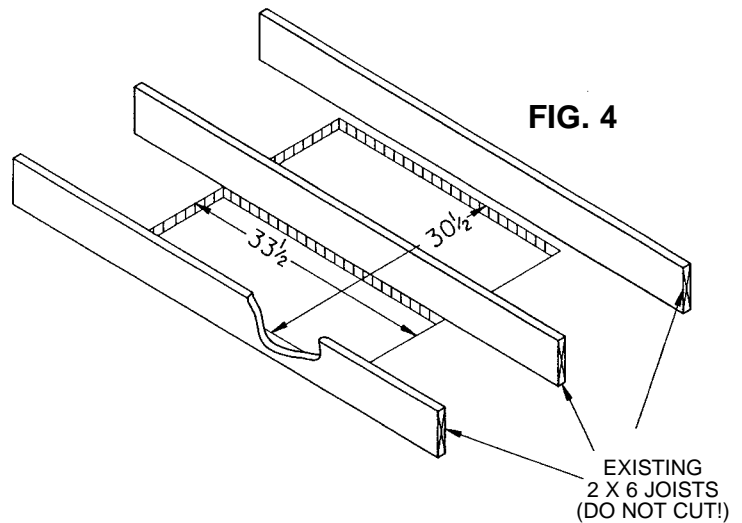
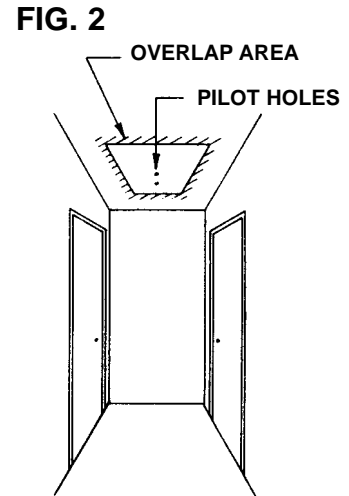
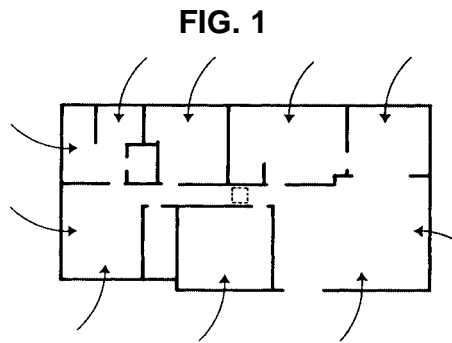

# WIRING

## STEP 6 — PRECAUTIONS: READ CAREFULLY BEFORE WIRING FAN!

- A. Electrical connections and all wiring should be in accordance with the National Electrical Code and all local codes that may apply.
- B. To avoid possibility of serious injury or electrical shock, the installer must disconnect electrical circuit supplying power prior to wiring fan.
- C. CAUTION: Incorrect wiring can cause motor failure and possibly fire. Marley Engineered Products will not accept liability for damage resulting from incorrect wiring. *Follow all wiring diagrams and instructions carefully!*
- D. This fan is designed to run on 120 volt A.C. 60 Hz power only.

**STEP 7** — The 3-speed control packed with this fan is used to operate the fan from a remote wall location. Generally the best location is in the hallway near the fan. The control should be in sight of the fan. Install a single switch box at the location chosen.

**STEP 8** — The wiring diagrams, Figs. 6 & 7, show two alternate methods of wiring fan control. If the 120V power supply is available at the fan, Fig. 6 should be followed. If the 120V power supply is available at the control, Fig. 7 should be followed. In either case, note that the brown control wire must be connected to the black (hot) wire from the 120 volt power supply

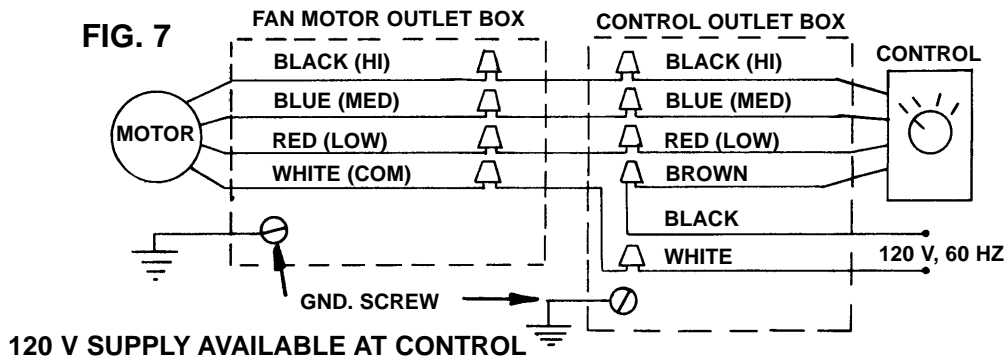
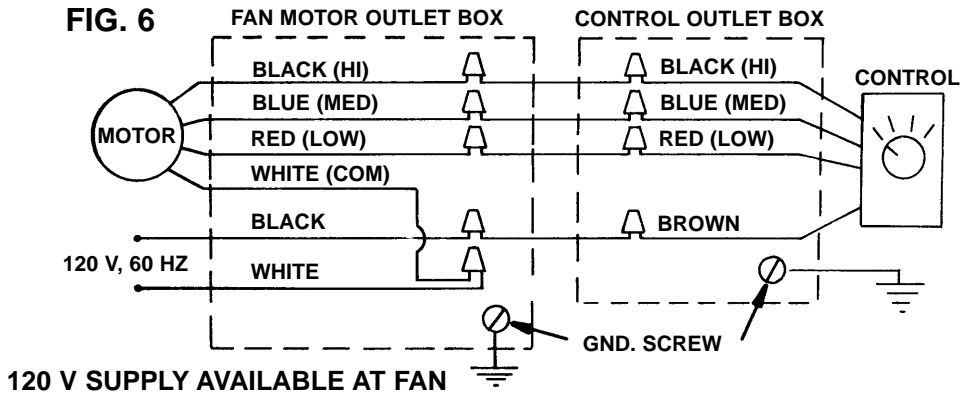

**STEP 9** — After determining which diagram applies, pull wires to fan and control switch box. Be sure to secure cable at fan to prevent it from being caught in fan blade. Make connections to fan from room below, through hole cut in ceiling. After wiring of fan and control is completed and checked against the appropriate wiring diagram, replace outlet box cover on fan and secure control in switch box. Leave control in "OFF" position.

## SHUTTER INSTALLATION

**STEP 10** — Unpack Model A3024 shutter and read instructions included. Note that the first part of the shutter instructions refer to cutting the shutter hole, which you have already done, and so they may be disregarded. Follow the remaining instructions to adjust springs so that shutters open and close freely. (See Fig. 8.)

**STEP 11** — Mount shutter to joists directly below fan opening with wood screws provided. Note sheet rock must be covering center joist before shutter is installed. Again, make sure both sides of shutter open and close freely. (See Fig. 9.)

**STEP 12** — Return to attic and attach side panels to fan as shown using remaining short screws and washers. (See Fig. 10.) Bottom of panels should rest upon ceiling. Bend flaps on ends of panels back when inserting panels between joists. These flaps will then spring back to seal off any space between panel and joist.

**STEP 13** — Fan installation is now complete. With control in "OFF" position turn on 120V power supply to fan. Test run fan through all speeds.

## WALL INSTALLATION MODEL 3130 SHUTTER

**THIS INSTALLATION IS TO BE USED ONLY IN AN ATTIC GABLE OR WALL WHICH FACES AN UNOCCUPIED AREA, AN AREA NOT READILY ACCESSIBLE TO PEOPLE OR ANIMALS! DO NOT USE THIS INSTALLATION IN AN ATTIC WITH ANY TYPE OF LOOSE INSULATION.**

**STEP 1** — Construct wood frame as shown in Figs. 11 & 12. Use 2 x 8 framing lumber and 2 x 2 furring strips.

**STEP 2** — Drill (4) holes  $\frac{1}{4}$ " in diameter in fan housing as shown in Fig. 13.

**STEP 3** — Position fan in frame and secure with (4) wood or lag screws (#12 x  $1\frac{1}{2}$ " preferred) through holes drilled in Step 2. Note  $3\frac{3}{4}$ " dimension from edge of frame. (Fig. 14)

**STEP 4** — Secure Model 3130 shutter with (8) wood or lag screws (#12 x 1" preferred) through holes in shutter frame. Shutter should be positioned so that louvers swing outward and upward. See Fig. 15. Check shutter to make sure it opens and closes freely. Also check to make sure there is clearance between shutter and fan blade.

**STEP 5** — To mount this attic fan in gable or wall, a box must be framed into wall construction as shown in Fig. 16. Make opening in outside wall 37" x 37".

**STEP 6** — Insert frame containing fan and shutter assembly into opening with outside surface of shutter frame flush with outside surface of wall. See Fig. 16.

FIG. 8

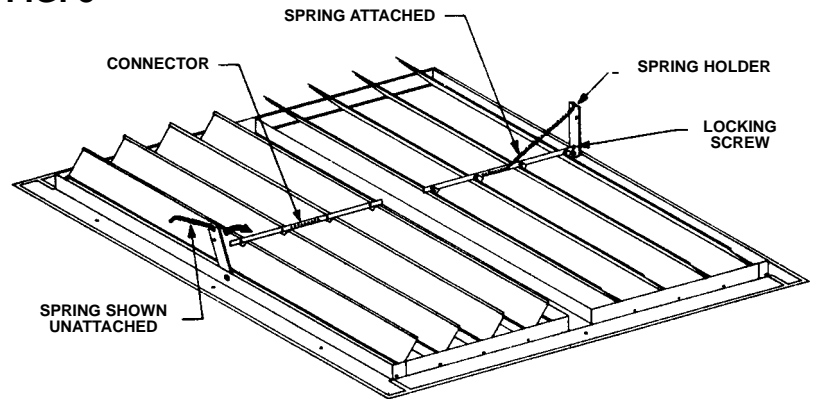

FIG. 9

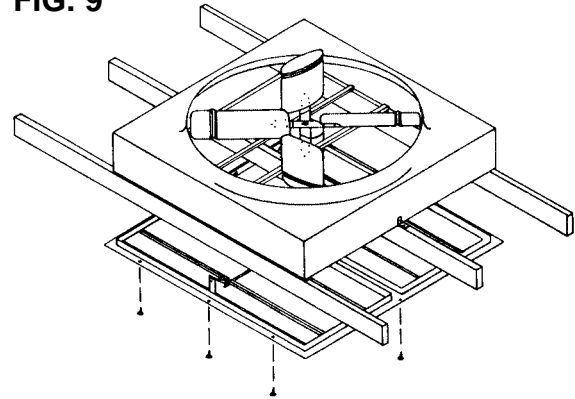

FIG. 10

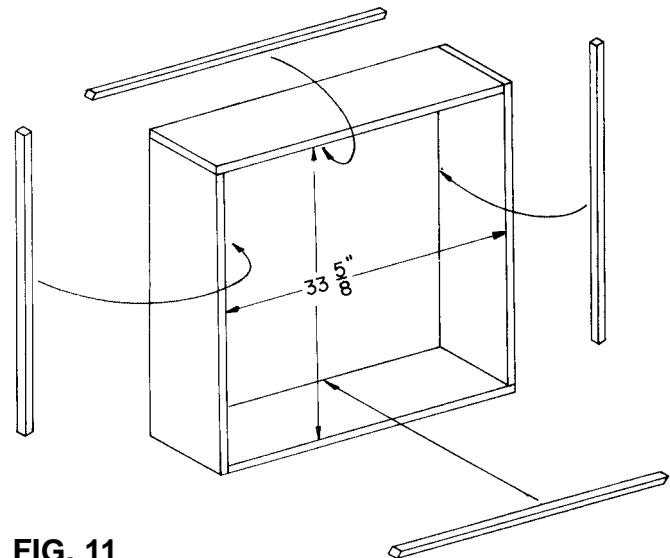
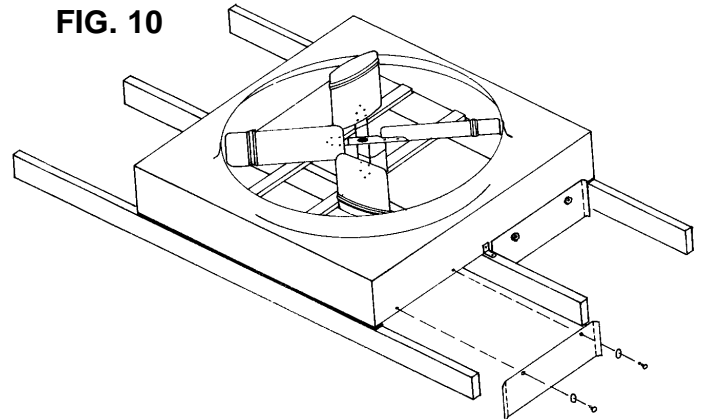
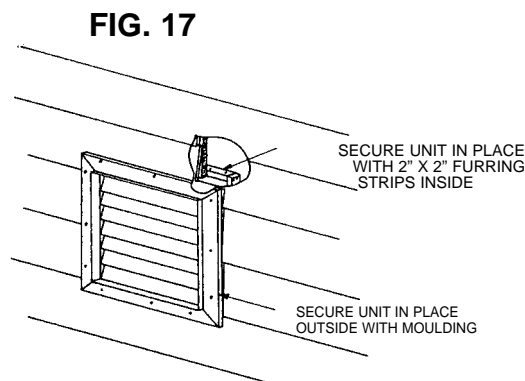
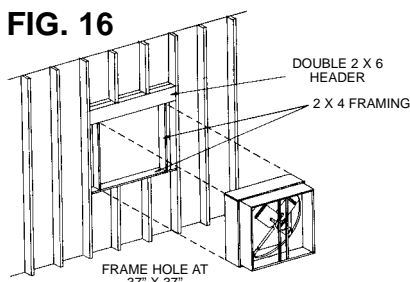
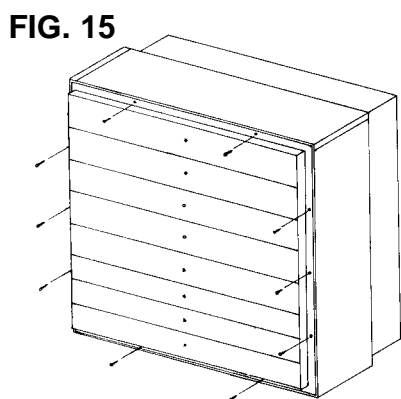
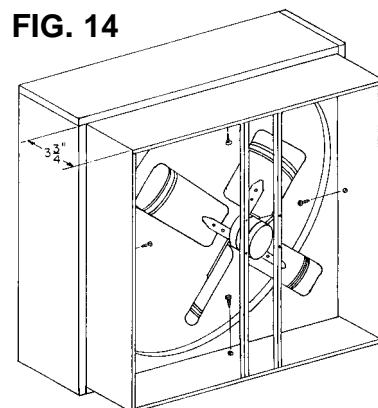
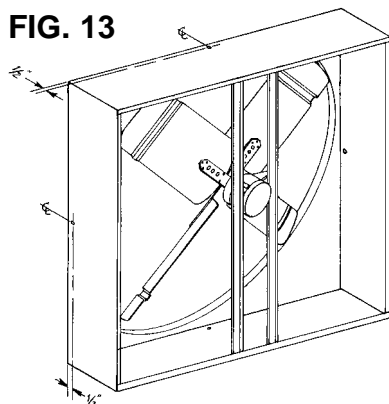
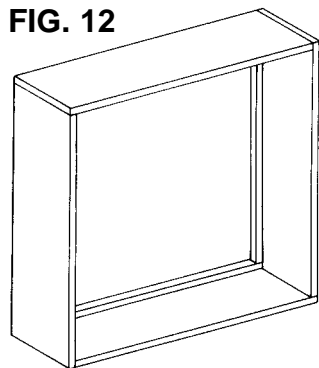

FIG. 11

**STEP 7** — Nail frame assembly securely in place with 2 x 2 furring strips. See Fig. 17. Put moulding around outside of shutter as shown in Fig. 17. Moulding should be at least 4" wide. Caulk around moulding to provide a water-tight seal. Check shutter again to be sure it opens and closes freely.

**STEP 8** — Wire fan to 120V power supply and 3-speed control. Follow steps 6 through 9 under wiring section of "CEILING INSTALLATION."

**STEP 9** — Fan installation is now complete. With control in "OFF" position turn on 120V power supply to fan. Test run fan through all speeds.



### ATTIC AIR INTAKE AND DISCHARGE

Your wholehouse ventilator will be discharging a large volume of air into the attic every minute. It is obvious that provisions must be made to allow this air to escape to the outside. The sketches below illustrate several different types of exhaust vents that are in common usage. Of these types, the under-eave and gable methods are the most prevalent. Under-eave exhaust is probably the most satisfactory from the standpoint of simplicity and economical installation.

Each size fan requires a given amount of minimum outlet in order to insure quiet operation and unrestricted air movement. The table below shows the minimum area to be provided for each fan, and the increased size that is required if the outlet is restricted with louvers, screening, etc.

Sufficient outlet air is most important. Unless enough is provided, the fan will be overloaded, and the motor will run hot, causing the thermal protector to turn it off. When it cools, it will start again. Such intermittent operation is usually an indication of too little outlet air or too little input air through the house.

### MINIMUM ATTIC DISCHARGE AREAS REQUIRED

(All areas are in square feet)

**FAN SIZE**

24"

**UNRESTRICTED\* OPENING REQD.**

8.5

**WOOD LOUVER\* OPENING REQD.**

19.2

**METAL LOUVER\* OPENING REQD.**

15

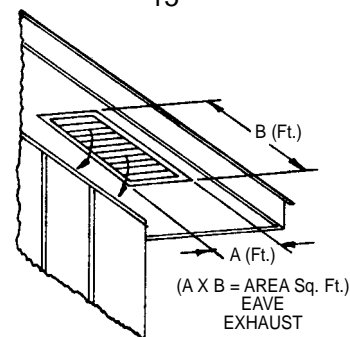
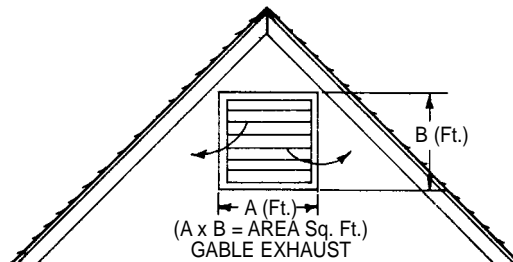
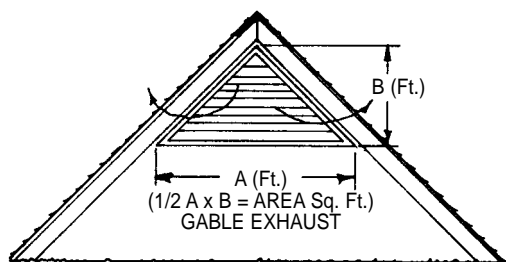

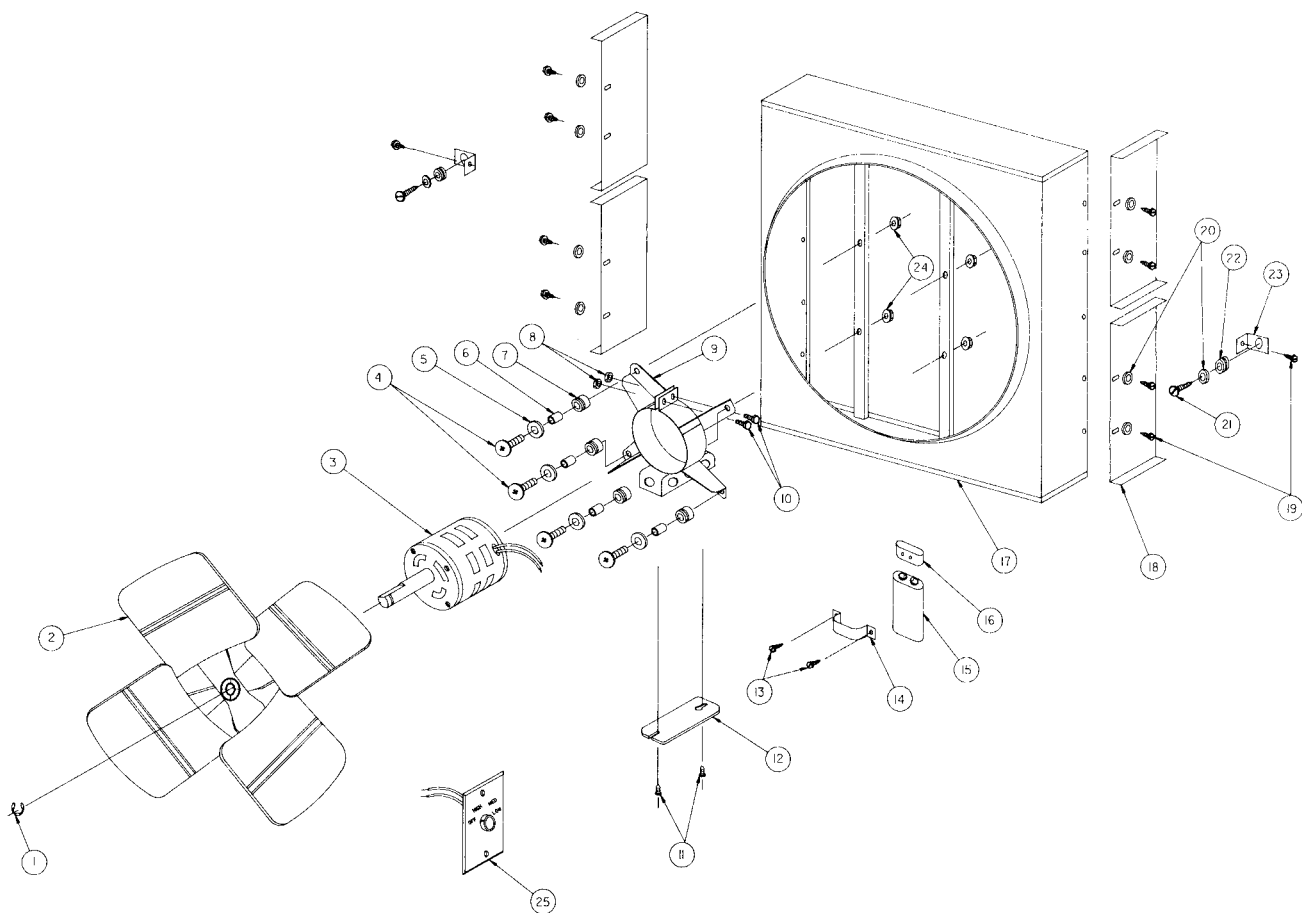

REF NO.	DESCRIPTION	QTY.	MODEL USED ON	REF NO.	DESCRIPTION	QTY.	MODEL USED ON
1	RETAINING RING	1	ALL	15*	CAPACITOR, 6 MFD 379V	1	A24DD
2	FAN BLADE ASSEMBLY - 24"	1	A24DD		CAPACITOR, 12.5 MFD 370V		B30DD
	FAN BLADE ASSEMBLY - 30"	1	B30DD	16	BOOT, CAPACITOR TERMINAL COVER	1	ALL
3	MOTOR, PSC 120V 1/3 HP 3 SPEED	1	A24DD	17	FAN HOUSING ASSEMBLY	1	A24DD
	MOTOR, PSC 120V 1/3 HP 3 SPE3D	1	B30DD		FAN HOUSING ASSEMBLY		B30DD
4*	SCREW, 1/4-20 X 1 TRUSS HEAD	4	ALL	18	PANEL, SIDE	4	ALL
5*	WASHER, FLAT 5/16" ID 7/8" OD	4	ALL	19*	SCREW, 10-16 X 1/2 TYPE AB	10	ALL
6	SPACER, 1/4" ID X 7/16"	4	ALL	20*	WASHER, 9/32" ID 5/8" OD	10	ALL
7	GROMMET, RUBBER	4	ALL	21	SCREW, 12-14 X 1 TYPE AB	2	ALL
8*	NUT, HEX LOCK 1/4-28	2	ALL	22	GROMMET, RUBBER	2	ALL
9	MOTOR MOUNT ASSEMBLY	1	ALL	23	BRACKET, MOUNTING	2	ALL
10*	SCREW, 1/4-28 X 7/8 HEX HEAD	2	ALL	24*	NUT, SERRATED FLANGE 1/4-20	4	ALL
11*	SCREW, 6-21 X 1/4	2	ALL	25	CONTROL ASSEMBLY - 3 SPEED	1	ALL
12	COVER, OUTLET BOX	1	ALL	26†	GASKET, 1/2" X 1/2" P/SENSITIVE	5.4 LF	ALL
13*	SCREW, 10-14 X 1/4	2	ALL	27†	INSTRUCTION SHEET	1	ALL
14	BRACKET, CAPACITOR MOUNTING	1	A24DD				
	BRACKET, CAPACITOR MOUNTING	1	B30DD				

\* STANDARD HARDWARE ITEM, AVAILABLE LOCALLY

† ITEM NOT SHOWN

## OPERATING HINTS AND SUGGESTIONS

1. Never operate a wholehouse ventilator with all outside doors and windows closed. Air will be drawn down the chimney, bringing soot into the house. This could also impair flue gas ventilation of furnaces, water heaters, etc. located in the house, possibly drawing fumes into the house. Be sure to open enough doors and windows to provide adequate ventilating air intake.
2. For best results, open windows in OCCUPIED rooms only. This will insure maximum breeze where you want it most. Before retiring at night, bedroom windows may be opened 15-20 minutes earlier in order to give the fan opportunity to draw out bedroom heat and bring in cooling air from the outside. Windows should be opened 4"-6" from the bottom for best results.
3. Experiment with the drawing power of the fan. It is possible, by regulating room doors and windows, to get the air movement through several rooms without actually opening windows in all the rooms. Air in the house acts like water in a pipe; it follows the path you provide.
4. **MAINTENANCE: TURN OFF ALL ELECTRIC POWER TO THE FAN AT THE CONTROL PANEL—REMOVE FUSE OR DISCONNECT CIRCUIT BREAKER BEFORE PERFORMING ANY MAINTENANCE.**  
If your motor is provided with oil caps, once each year, after 3 years use, oil the front and rear motor bearings with four drops of SAE 20 weight non-detergent motor oil.
5. Check fan periodically for insulation or any foreign materials having fallen into or onto any part of the fan.

## ACCESSORIES

The model 1012A Timer may be used to control the fan if it is desirable to run the fan after retiring at night. This timer can be set manually to run up to 12 hours, turning fan off automatically at the pre-set time.

### LIMITED WARRANTY

Dear Customer,

Thank you for your interest in Marley Engineered Products products. We're sure you will enjoy its benefits for many years to come. Please take a minute to fill out the following information and keep it in your permanent records.

Date Purchased \_\_\_\_\_ Date Installed \_\_\_\_\_

Model Number \_\_\_\_\_

#### LIMITED WARRANTY

This Marley Engineered Products product is warranted to be free of defects in material and workmanship for 12 months from date of original purchase.

There is no other warranty, express or implied, except such as is expressly set forth herein. Seller will not be liable for any general, consequential, or incidental damages, including without limitation any damages for loss of use or loss of profits, for any breach of warranty or for negligence. Seller's liability and buyer's exclusive remedy are limited to the repair of defective goods or the shipment of equivalent goods, or the granting of a reasonable allowance on account of any defects, as the seller may elect.

To obtain performance under this warranty, you must:

1. Contact the Marley Engineered Products Service Department at 1-800-642-HEAT between the hours of 8:00 a.m. and 5:00 p.m. E.S.T. Monday through Friday.
2. Provide the model number of the product, the date of installation, and state the nature of the difficulty being experienced.

3. The Marley Engineered Products Service Representative will determine the best way to resolve the difficulty.

Products within warranty which have been installed and returned to the seller for repair will be repaired and returned as used products. Repairs to products outside the warranty period will be subject to labor and parts charges.

Some states have enacted legislation which (a) does not allow the inclusion of limitations on incidental or consequential damages; (b) does not allow limitations on the length of a warranty period; (c) precludes exclusion, during the period of a limited warranty, of any implied warranties of merchantability or fitness for purpose.

To the extent of such provisions being applicable in your state, the limitations in this warranty may not apply.

#### TO ENSURE SAFE OPERATION

- Be sure that this unit is correctly installed and wired by a qualified installer in accordance with the instructions and applicable NEC or equivalent codes.
- Be sure that operating instructions are followed and that moving and heating parts are kept clean and free from obstructions.

Any warranties granted or liabilities assumed hereunder will not apply to goods that have been damaged in transit, altered, repaired, installed or operated otherwise than in conformity with the above requirements for safe operation.

## HOW TO ORDER REPAIR PARTS

In order to obtain any needed repair or replacement parts, warranty service or technical information, please contact Marley Engineered Products Service Center toll-free by calling 1-800-642-HEAT.

When ordering repair parts, always give the information listed as follows:

1. The Part Number
2. The Model Number
3. The Part Description
4. Date of Manufacture



**Marley**  
Engineered Products

SPX Corporation  
470 Beauty Spot Rd. East  
Bennettsville, SC 29512 USA