

Sunbeam

MultiBlender Electronic

850 watt electronic blender with
7 programmed functions

Instruction Booklet

PB7950

Please read these instructions carefully
and retain for future reference.



Contents

Sunbeam's Safety Precautions	1
Features of your MultiBlender Electronic	2
Before using your MultiBlender Electronic	4
Using your MultiBlender Electronic	5
A Guide to your MultiBlender Electronic	6
Handy Blending Hints	7
Care and Cleaning	8
Recipes	
Soups	9
Dips/Starters/Pastes	11
Light Snacks	14
Desserts	15
Drinks	17
Thick Shakes	19
Cocktails	20

تأكد من تفهم احتياطات السلامة المذكورة اعلاه

請務必理解上述的安全預防措施。

Assurez-vous que les précautions ci-dessus relatives à la sécurité sont bien comprises

Versichern Sie sich, dass die obenstehenden Sicherheitsmaßnahmen Verstanden werden

Βεβαιώνετε πως οι παραπάνω προφυλάξεις ασφαλείας γίνονται κατανοητές

Pastikan bahwa tindakan-tindakan keselamatan seperti di atas dimengerti anda

Accertatevi che le suddette norme di sicurezza siano comprese a dovere

上記の注意事項をよくお読みになり、安全を御確認ください

Уверете се дека погоре споменатите мерки на претпазливост се добро разбрани

Asegúrese de que las precauciones de seguridad precedentes sean bien comprendidas

کاری بکنید کہ احتیاطهای بالا حتماً درک بشوند

ต้องแน่ใจว่า ข้อควรระวังเรื่องความปลอดภัยข้างต้น เป็นที่เข้าใจกันดี

Yukarda belirtilen güvenlik önlemlerinin anlaşılığından emin olunuz

Xin kiểm chắc rằng những biện pháp làm an toàn kể trên được hiểu rõ

Sunbeam's Safety Precautions

SAFETY PRECAUTIONS FOR YOUR SUNBEAM MULTIBLENDER ELECTRONIC PB7950

- Ensure fingers are kept well away from the blades when in use.
- Always operate on a flat surface.

Sunbeam are very safety conscious when designing and manufacturing consumer products, but it is essential that the product user also exercise care when using an electrical appliance. Listed below are precautions which are essential for the safe use of an electrical appliance:

- Read carefully and save all the instructions provided with an appliance.
- Always turn the power off at the power outlet before you insert or remove a plug. Remove by grasping the plug - do not pull on the cord.
- Turn the power off and remove the plug when the appliance is not in use and before cleaning.
- Do not use your appliance with an extension cord unless this cord has been checked and tested by a qualified technician or service person.
- Always use your appliance from a power outlet of the voltage (A.C. only) marked on the appliance.
- Close supervision is necessary when your appliance is being used near children or infirm persons.
- Never leave an appliance unattended while in use.
- Young children should be supervised to ensure that they do not play with the appliance.

- When using heavy loads this blender should not be operated for more than 1 minute and 40 seconds, this does not apply to any of the recipes detailed in this instruction booklet.
- Do not blend hot ingredients.
- Do not use an appliance for any purpose other than its intended use.
- Do not place an appliance on or near a hot gas flame, electric element or on a heated oven. Do not place on top of any other appliance.
- Do not let the power cord of an appliance hang over the edge of a table or bench top or touch any hot surface.
- For safety reasons and to avoid maintenance by unskilled persons, some appliances are 'sealed' using tamperproof screws. Such appliances should always be returned to the nearest Sunbeam Appointed Service Centre for adjustment or repair if required.
- Do not operate any electrical appliance with a damaged cord or after the appliance has been dropped or damaged in any manner. If damage is suspected, return the appliance to the nearest Sunbeam Appointed Service Centre for examination, repair or adjustment.
- For additional protection, Sunbeam recommend the use of a residual current device (RCD) with a tripping current not exceeding 30mA in the electrical circuit supplying power to your appliances.
- Do not immerse the appliance in water or any other liquid unless recommended.

If you have any concerns regarding the performance and use of your appliance, please visit www.sunbeam.com.au or contact the Sunbeam Consumer Service Line.

Ensure the above safety precautions are understood.

Features of your MultiBlender Electronic

Ingredient cup.

Handy 70ml ingredient cup. Also acts as a device to unscrew the blade assembly from the base of the jug.

Flexible lid with pouring hole.

To provide the necessary safety, the lid seals tightly to the jug and features a pouring hole, that allows you to add ingredients during the blending process.

1.6 litre heat-resistant jug.

The sizeable 1.6 litre glass jug features specially designed internal ribs to cycle ingredients back into the blade system for superior results.

The jug features an easy to pour lip and is marked in both cups and millilitres (mL) for ease of use. The heat-resistant jug is ideal for pureeing warm soups.

Detachable blade system assembly.

The detachable blade assembly unit unscrews from the glass blending jug for convenient and thorough cleaning.

Motor base.

The base houses a powerful 850 watt motor providing superior performance for every blending task.

Non-slip feet.

Keeps the blender secure on the bench top during use.

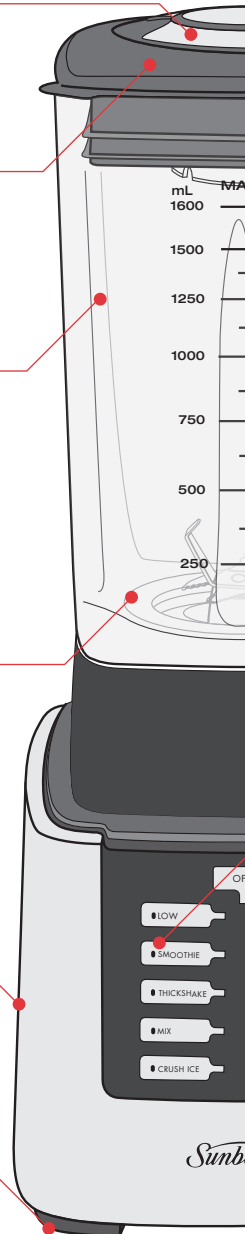

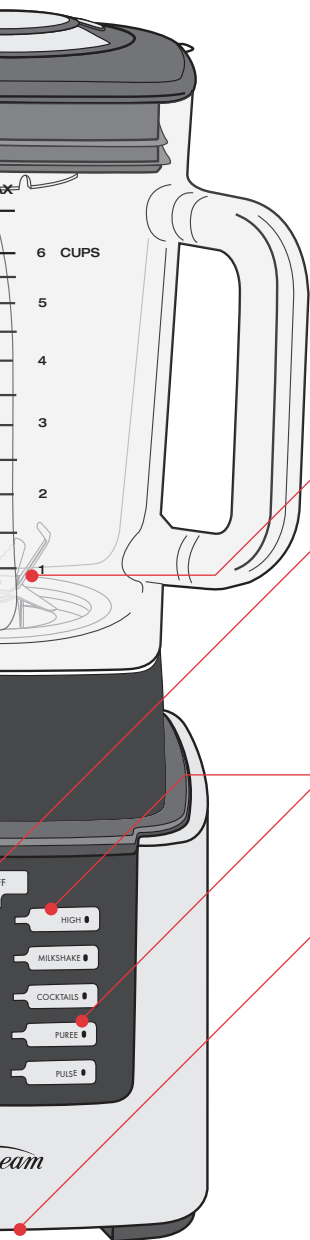

Serrated stainless steel six-blade system.

Specially designed for extra durability, the heavy-duty, serrated stainless steel blade with a six-blade construction, crushes ice cubes to powder, produces a smooth consistency when pureeing and combines ingredients perfectly for a frappé.

Recipe programs.

Three blending favourites milkshake, thickshake and smoothie. Just add ingredients and each of these programs have been developed to ensure perfect consistent results everytime.

Functional programs.

To assist with some of the more functional blender uses, these four programs (mix, puree, cocktail and ice crush) have been tested and refined, to remove the guess work and improve on the final blending result.

Manual operation.

Low and High speed control plus Pulse.

Cord storage facility.

For tidy, convenient storage of the cord underneath the motor base.

Before using your MultiBlender Electronic

Important: Always ensure your blender is unplugged from the power outlet before fitting or removing the blade assembly. Always handle the blade assembly with caution, as the blades are extremely sharp.

To assemble the six-blade system in the glass jug (see Figure 1).

1. Place the silicone rubber seal over the six-blade assembly, as shown in figure 1.

Figure 1

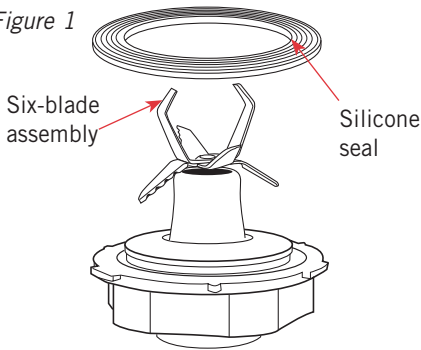

2. Place the six-blade assembly into the glass jug and turn clockwise to secure firmly into position (see Figure 2).

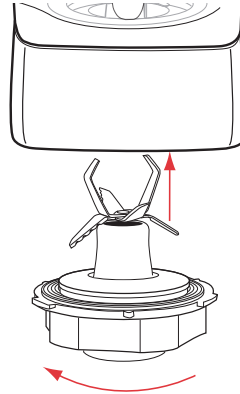

Figure 2

Note: The blender jug will leak if the six-blade system is not assembled correctly.

Note: Do not attempt to remove the stainless steel blades from the blade assembly.

3. Plug the power cord into a 230-240 volt power outlet and turn the power 'ON'.

Using your MultiBlender Electronic

1. Place the blender jug onto the motor base.

Note: Do not switch 'ON' the MultiBlender Electronic without the lid in position.

2. Place ingredients into the glass jug. Do not exceed the maximum indicated level – 1.6 litres.
3. Position the lid with ingredient cup onto the blender jug. Ensure the lid is firmly in place.
4. Using the control panel, select the desired function, either from the pre-programmed functions or the manual buttons High, Low and PULSE settings.

The Blending Guide on page 6 shows various functions that can be performed and the suggested speeds to use.

Note: Although the lid fits firmly to the glass jug, we advise when blending liquid ingredients, to place your hand on the lid as you initially select the blending speed/function. As the powerful 850 watt motor could cause the liquid to surge up causing leakage. Once you have started blending you can remove your hand.

Further ingredients can also be added

while blending by removing the ingredient cup and pouring ingredients through the hole in the lid.

Note: The pre-programmed functions can be stopped by simply pressing the 'OFF' button.

5. If using the manual buttons, Low or High, once you have completed blending, press the 'OFF' button on the control panel.

Note: When removing the six-blade assembly from the glass jug you may need to slightly tilt the blade so that it slides out easily. You shouldn't force the blades out of the glass jug as this will ultimately damage the blades.

A Guide to your MultiBlender Electronic

Processing Task	Food	Suggested Setting	Programme	Suggested Processing Procedure
Aerating	Milkshakes, Smoothies	HIGH	Milkshake	Use chilled milk. Blend until desired consistency is achieved.
Chopping	Nuts, Chocolate, Garlic or Herbs	PULSE		Process ½ cup at a time, to ensure evenly sized pieces.
Crumbing	Bread Crumbs	PULSE		Tear bread roughly. Process until desired consistency.
	Biscuit Crumbs	PULSE		Break into pieces and process until crumbed.
Crushing Ice		PULSE	Crush Ice	Add ¼ cup of water. Use the PULSE button 3-4 times in succession for crushed ice.
Emulsifying	Salad Dressing	LOW	Crush Ice & Cocktails	Blend until well combined. Oil may be added to the mixture during processing through the pouring hole in the lid.
Mixing	Batters, Cakes	LOW & HIGH	MIX	Process ingredients until just combined. DO NOT OVERPROCESS.
Pureeing	Soups, Vegetables, Fruits	HIGH	PUREE	Blend until smooth.

Handy Blending Hints

- Nothing can beat a blender for making smooth purees and sauces or for whipping up frothy drinks – from healthy breakfast shakes to frozen daiquiris.
- Use your blender for chopping small amounts of food like nuts, bread crumbs and whole spices.
- Turn any oil-based salad dressing into a creamy style dressing by blending it until slightly thickened.
- A brief whirl in the blender will rescue a lumpy gravy, or an egg-based sauce that has separated.
- Food items for blending should be cut into cubes (approximately 2-3cm), this will assist in achieving an even result.
- Ensure the lid is firmly and securely placed on the jug. Do not operate the blender without the lid on, if you wish to add any additional ingredients remove the ingredient cup and add as necessary.
- Never fill above the maximum level indicator – 1.6 litres.
- To ensure efficient mixing when blending dry mixtures, it may be necessary to stop the blender and push ingredients down the sides of the jug with a spatula.
- When pureeing fruit or vegetables, cooked or raw, cut into small pieces to facilitate blending.
- When making bread crumbs, use 2 to 3 day old bread, leaving crusts on, to minimise the possibility of clumping. If only fresh bread is available, dry it out for a few minutes in a low heated oven.
- When blending a variety of ingredients together, blend the liquids first, then add dry ingredients.
- Always ensure stones are removed from fruit and bones from meat as these can harm the blades.
- Don't allow a used blender to sit for too long as the food will dry onto the blades, making it very difficult to clean. If you can't clean the blender straight away, pour some warm water in it and allow to soak.
- Do not process hot liquids in your blender. Allow to cool before processing.
- Always ventilate the blender jug when pureeing warm ingredients. This is achieved by lifting the ingredient cup out of the lid after starting the blender.

Care and Cleaning

Quick cleaning method.

Half fill the blender with warm water and a small amount of detergent. Press the PULSE button for 10-20 seconds. Then remove the jug and rinse it under running water.

For thorough cleaning.

Turn the blender jug upside down. Unscrew the six-blade assembly from the glass jug by placing the open end of the ingredient cap to align the cap to the base of the glass jug. Use the 5 grooves on the opening of the ingredient cap to align the cap to the base of the glass jug. Turn the ingredient cap in an anti-clockwise direction to remove the blade assembly. See Figure 3.

Figure 3

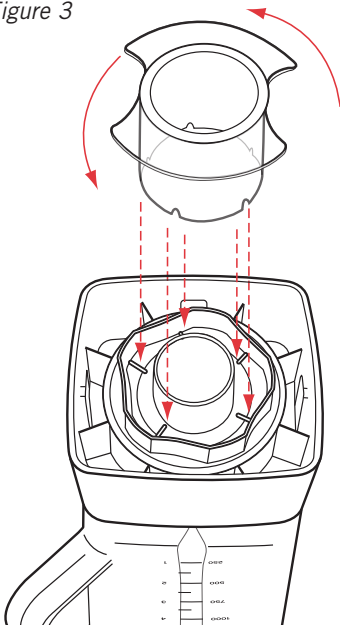

Remove the rubber seal from the blade assembly. Wash the blender lid, ingredient cup, rubber seal, blade assembly and blender jug in warm soapy water.

Caution: Take care when cleaning the blades as they are extremely sharp.

Note: Do not clean any part of the blender in the dishwasher.

To clean the motor base.

Use a damp, soft sponge with mild detergent and wipe over the motor base.

Note: Never immerse the motor base in water.

Recipes – Soups

Potato and Leek Soup

Serves 4

- 1 tablespoon olive oil
- 2 small rashers bacon, chopped
- 3 medium leeks, sliced thinly
- 1 kg potatoes, peeled and chopped roughly
- 2 litres chicken or vegetable stock
- Freshly ground black pepper
- ½ cup grated Parmesan

1. Heat oil in a large saucepan; add bacon and cook, stirring occasionally, until crisp. Remove from pan.
2. Add leeks to the same pan and cook, stirring for about 5 minutes or until leeks are tender. Add potatoes and stock and bring to the boil; reduce heat and simmer, uncovered, for about 40 minutes.
3. Remove from heat; cool. Place half of the soup mixture into the blender jug and press the 'PUREE' button. When the cycle has finished, pour back in with remainder of soup.
4. Add cooked bacon to soup and reheat until soup is hot. Season to taste with freshly ground pepper.
5. Serve soup topped with parmesan cheese.

Mexican style Tomato Soup

Serves 4

- 1 tablespoon olive oil
- 2 onions, chopped
- 2 cloves garlic, crushed
- 2 teaspoons cumin powder
- 1 teaspoon chilli powder
- 3 x 400g can chopped tomatoes
- 500ml water

- 1 teaspoon brown sugar
- 1 tablespoon vinegar
- 2 x 400g cans red kidney beans, rinsed, drained
- Sour cream and flour tortillas to serve

1. Heat oil in a large saucepan, add onions and garlic and cook on a medium heat until onions start to soften; add the cumin and chilli powder and cook, stirring, until the spices become fragrant. Add the tomatoes, and water; simmer for 20 minutes. Remove from heat; cool.
2. Stir through the sugar, vinegar and beans; allow to cool.
3. Place half of the soup mixture into the blender jug and press the 'PUREE' button. Pour contents of blender jug into a container and repeat this step with the remaining soup mixture.
4. Return soup to saucepan to heat through; serve with sour cream and warm flour tortillas.

Recipes – Soups (continued)

Roast Pumpkin Soup

Serves 6

1.5 kg pumpkin
2 tablespoons olive oil
Sea salt & freshly ground black pepper
20g butter
1 onion, chopped
1 litre chicken stock
1/3 cup cream or sour cream to serve (optional)

1. Preheat oven to 200°C.
2. Remove skin and seeds from pumpkin and cut into even sized chunks.
3. Place pumpkin in an oven dish and drizzle with half the oil. Season with a little salt and pepper. Bake in oven for about 40 minutes or until cooked.
4. In a large saucepan heat remaining oil and butter. Add onion and cook until tender. Add the pumpkin and stock and bring to the boil. Reduce heat, simmer, uncovered, for 10 minutes. Cool before blending.
5. Place half of the soup mixture in blender and press the 'PUREE' button. Repeat with remaining soup mixture.
6. Reheat until soup is hot. Serve with cream and extra ground pepper if desired.

Vegetable Soup

Serves 4-6

1 tablespoon olive oil
1 onion, chopped
2 cloves garlic, crushed
2 carrots, diced
1 potato, diced
2 trimmed celery stalks, diced finely
800g can chopped tomatoes
6 cups water
1 cup chopped savoy cabbage
2 small zucchini, diced
100g button mushrooms, sliced
sea salt and freshly ground black pepper

1. Heat oil in frying pan on setting 5. Cook onion and garlic until translucent. Add carrot, potato and celery; cook, stirring occasionally for 5 minutes.
2. Add the chopped tomatoes, cabbage, zucchini, mushrooms and water and bring the soup to the boil. Reduce heat to a simmer and cook, covered for about 45 minutes or until vegetables are tender.
3. Remove from heat and allow to cool. Place the soup in batches into the blender jug and press the 'PUREE' button.
4. Return soup to saucepan and reheat until hot.

Tip: For a soup with more texture you can simply puree only half the soup.

Recipes – Dips/Starters/Pastes

Hummus

420g can chickpeas, rinsed, and drained
2 tablespoons tahini
¼ cup lemon juice
¼ cup water
¼ cup olive oil
1 clove garlic, crushed
½ teaspoon ground cumin
½ teaspoon salt

1. Place all ingredients in the blender jug.
2. Press the 'PUREE' button.
3. Transfer mixture into a bowl and refrigerate for 1-2 hours before serving.

Serving suggestions: Serve hummus with toasted pita crisps; simply cut pita bread into triangles, brush with olive oil and season with a little salt and cumin seeds. Bake in oven at 200°C for about 5 minutes or until crisp.

Serves 4

Guacamole

2 ripe avocados, peeled, seeds removed
1 clove garlic
1 tablespoon lemon juice
dash Tabasco sauce
1 jalapeno chilli, sliced
¼ cup fresh coriander leaves
1 tomato, chopped

1. Place all ingredients except tomato in the blender jug.
 2. Press the 'PUREE' button.
 3. Transfer mixture to a bowl and stir through tomato.
 4. Refrigerate for 1 hour before serving.
- Serve with corn chips and salsa

Recipes – Dips/Starters/Pastes (continued)

Pesto

125g fresh basil leaves
3 cloves garlic
2 teaspoons lemon juice
sea salt
freshly ground black pepper
1 cup extra virgin olive oil
½ cup pine nuts, roasted
60g pecorino or parmesan, grated

1. Place the basil, garlic, juice, salt, pepper and oil in the blender jug. Blend on 'HIGH' for 20 seconds.
2. Push down any ingredients that may have come up the sides of the jug and add the nuts and cheese. Blend on 'HIGH' for a further 20 seconds or until a smooth texture is achieved. If a nutty texture is desired only blend on 'HIGH' for 5-10 seconds.

To serve: Boil a large pot of boiling water with a little oil in it. Boil 500g pasta until just tender. Drain pasta well but do not rinse. Place hot pasta back in to pot and stir through half of the pesto sauce. Add more pesto to taste if desired. Serve with extra cheese and a sprinkle of toasted pine nuts.

Tip: To keep pesto sauce for a few days in the refrigerator simply place pesto into a clean container and pour enough olive oil over top to cover, this will stop the pesto from discolouring. Cover with lid or plastic wrap.

Serves 4

Whole Egg Mayonnaise

Approx. 1½ cups

1 egg
1 tablespoon lemon juice
2 teaspoons Dijon mustard
pinch sea salt
1 cup vegetable oil

1. Place egg, juice, mustard and salt in the blender jug. Blend on 'LOW' for 10 seconds or until combined.
2. With the motor still running remove the measuring cup from the lid, start to pour in the oil in a slow, thin stream until the mixture is creamy and all the oil has been added.
3. Keeps in the refrigerator for 1 week.

Recipes – Dips/Starters/Pastes (continued)

Baba Ghanoush

2 large eggplants
2 cloves garlic
2 tablespoons tahini
¼ cup lemon juice
¼ teaspoon sweet paprika
sea salt and freshly ground black pepper
1 tablespoon Extra Virgin
olive oil

1. Pierce eggplants all over with a fork. Cook eggplants under a griller until the skin blackens and the flesh is soft. Allow eggplants to cool for 20 minutes before removing skin; drain for 10 minutes.
2. Place all ingredients into blender jug. Place lid onto jug and press the 'PUREE' button. Check mixture and scrape sides if necessary. Blend on low to finish blending if needed.
3. Transfer mixture into a bowl and refrigerate for 1-2 hours before serving. Drizzle extra virgin olive oil over the top before serving.

Serve with crusty fresh bread

Herbed Mushroom Pate **Approx. 1½ cups**

50g butter or margarine
1 onion, roughly chopped
300g mushrooms, sliced
200g cream cheese, cubed
1 tablespoon freshly chopped chives
salt and freshly ground black pepper to taste

1. Heat butter in a frying pan over a medium heat. Cook onion and mushrooms until soft; cool.
2. Place mushroom mixture into blender jug with remaining ingredients.
3. Press the 'PUREE' button.
4. Pour into serving bowl and refrigerate for at least 2 hours before serving.
5. Serve with Melba toasts.

Recipes – Light Snacks

Sweet potato and rocket frittata Serves 8

1 small sweet potato
80g baby rocket leaves
200g fetta cheese, crumbled
250ml thickened cream
10 eggs
Sea salt and freshly ground black pepper,
to taste
½ cup grated tasty cheese

1. Preheat oven to 200°C. Grease and line base of a 19cm square shallow cake tin.
2. Peel the sweet potato and slice thinly.
3. Place a layer of sweet potato then rocket then fetta into the cake tin and then repeat layers again. Reserve a few sweet potato slices if possible for the top.
4. Combine the eggs, cream, salt and pepper in blender and blend on HIGH until smooth. Pour egg mixture into the cake tin and top with the grated cheese.
5. Place frittata into oven and cook for about 30-35 minutes or until cooked through. If the frittata starts to brown too much before the inside is completely cooked lay a piece of foil over the top, this will stop excessive browning.

Bacon and Cheese Quiche

1 large sheet ready made frozen shortcrust pastry
6 bacon rashers, rind removed, roughly chopped
1 small onion, chopped finely
1½ cups grated tasty cheese
4 eggs
1 cup milk
½ cup cream
½ cup self raising flour
pepper to taste

1. Preheat oven to 180°C. Line quiche dish with pastry and trim edges. Prick pastry all over with a fork.
2. Cook bacon in a frying pan until tender, remove from pan and drain on absorbent paper; cool.
3. In a large bowl combine the bacon, onion and cheese.
4. Place all the remaining ingredients into the blender jug.
5. Press the 'MIX' button.
6. Place the bacon mixture into the prepared quiche dish and pour the egg mixture over the top.
7. Bake in oven for about 50 minutes or until cooked. Allow quiche to stand for 10 minutes before cutting.

Recipes – Desserts

Baked Lemon Cheesecake

Serves 10

250g plain biscuit crumbs
2 teaspoons nutmeg
125g melted butter
250ml thickened cream
3 eggs
½ cup caster sugar
2 teaspoon grated lemon rind
2 tablespoons lemon juice
500g cream cheese, room temperature, cubed

1. Crush biscuits 5-6 at a time using the 'PULSE' button until crumbled. Remove jug from base and shake biscuits if necessary. Combine the nutmeg, melted butter and biscuit crumbs in a bowl; mix well. Press crumb mixture into the base and sides of a greased 20cm springform pan. Place on a baking tray and refrigerate for 30 minutes.
2. Place cream, eggs, sugar, rind, juice and half of the cream cheese in blender.
3. Press the 'MIX' button. With the motor still running, remove the ingredient cup from the lid and drop in the remaining cubes of cream cheese one at a time, until the mixture is smooth.
4. Pour filling into crust and bake in oven at 160°C for approximately 50 minutes or until firm. Cool in oven with door ajar. Refrigerate for several hours before serving.

Banana Cake with Cream Cheese Frosting

2¼ cups self raising flour
½ teaspoon salt
1 teaspoon cinnamon
½ teaspoon nutmeg
2 eggs
180g butter, room temperature, chopped
½ cup buttermilk
1½ cups raw sugar
1 teaspoon white vinegar
1 teaspoon vanilla essence
1½ cups very ripe mashed banana

1. Preheat oven to 180°C. Grease and line a 20cm baba pan.
2. Sift flour, salt, cinnamon and nutmeg into a large bowl.
3. Place the eggs, butter, milk, sugar, vinegar, essence, and bananas into blender jug.
4. Press the 'MIX' button. (Mixture will separate at this stage but will come back together when mixed with dry ingredients).
5. Pour the banana mixture into the dry ingredients and mix with a wooden spoon or whisk until combined.
6. Pour mixture into prepared tin and bake for about 40 minutes or until cooked when tested with a skewer.
7. Allow cake to cool in pan for 5 minutes before transferring to a wire rack to cool.
8. Ice with cream cheese frosting, recipe over page.

Recipes – Desserts (continued)

Cream Cheese Frosting

- 250g softened cream cheese
- ¼ cup butter
- 1 teaspoon vanilla
- 3 cups icing sugar mixture
- ¼ cup passionfruit pulp

Combine cream cheese, butter and vanilla in a small bowl. Using an electric mixer beat until smooth. Add the icing sugar mixture and beat until smooth. Reduce speed and add passionfruit. Spread over cooled cake.

Sticky Date Pudding

Serves 8

- 200g coarsely chopped dried dates
- 1 teaspoon bicarbonate soda
- 1 ¼ cups boiling water
- 60ml olive oil
- 1 cup firmly packed brown sugar
- 1 cup self raising flour
- ¼ teaspoon mixed spice
- 2 eggs

Butterscotch sauce

- 140g butter
- 2/3 cup firmly packed brown sugar
- 1 cup (250ml) thickened cream

1. Preheat oven to 180°C. Grease and line a 20cm cake pan with baking paper.
2. Place dates, soda and water into the blender jug. Place the lid on and allow the mixture to stand for 5 minutes.
3. Add oil and sugar and pulse 3 times.
4. Add remaining ingredients and pulse mixture until just combined. Scrape down sides of jug if necessary. Do not over process.

5. Pour mixture into prepared pan and bake for about 1 hour or until cooked when tested with a wooden skewer. Remove from oven and stand for 5 minutes before turning out onto a wire rack.
6. Serve pudding with butterscotch sauce. To make sauce, heat all ingredients in a small saucepan over a low heat until combined.

Honey Pikelets

Makes 30

- 3 large eggs
- ¼ cup honey
- 1 cup milk
- 1½ cups self raising flour
- pinch salt

1. Add all ingredients into the blender jug and blend on 'LOW' for 30 seconds. Scrape down sides of blender and blend again on 'LOW' for a further 30 seconds.
2. Pour mixture into a jug and refrigerate for 30 minutes.
3. Place tablespoon amounts of mixture into a lightly greased frying pan until golden on each side.
4. Serve with butter.

Recipes – Drinks

Classic Banana Smoothie

Serves 2

2 cups skim milk
2 medium bananas, roughly chopped
½ cup low fat yogurt
1 tablespoon honey
¼ teaspoon cinnamon

1. Place all ingredients into blender jug.
2. Press the 'SMOOTHIE' button.
3. Pour into 2 glasses.

Classic Milkshake

Serves 2

250ml milk
2 scoops ice cream – any flavour
2 tablespoons topping – any flavour

1. Place all ingredients into blender jug.
2. Press the 'MILK SHAKE' button.
3. Pour into 2 glasses.

Strawberry Milkshake

Serves 2

6 strawberries
2 cups milk
2 scoops strawberry ice cream

1. Place all ingredients into blender jug.
2. Press the 'MILK SHAKE' button.
3. Pour into 2 glasses.

Milo Madness

Serves 2

2 cups milk
2 scoops vanilla ice cream
3-4 tablespoons Milo

1. Place all ingredients into blender jug.
2. Press the 'MILK SHAKE' button.
3. Pour into 2 glasses, dust with extra Milo.

Fruity Fantasy

Serves 2

180ml fresh orange juice
90ml pineapple juice
1 punnet strawberries
slice honeydew melon
slice rockmelon
8 small ice cubes

1. Place all ingredients into blender jug.
2. Press the 'SMOOTHIE' button.
3. Pour into 2 glasses.

Recipes – Drinks (continued)

Citrus Buzz

Serves 2

60ml fresh lime juice
4 dashes Angostura bitters
8 small ice cubes
lemonade

1. Place all ingredients except for lemonade into blender jug.
2. Press the 'SMOOTHIE' button.
3. Pour into 2 glasses, top with lemonade.

Iced Coffee

Serves 2

2 tablespoons instant coffee dissolved in
2 tablespoons boiling water
2 cups milk
2 scoops vanilla ice cream
whipped cream to serve

1. Place all ingredients except for cream into blender jug.
2. Press the 'MILK SHAKE' button.
3. Pour into 2 large glasses, top with whipped cream and dust with chocolate.

Frosty Fruity Smoothie

Serves 2

1 banana
1 cup tropical juice
½ cup milk
3 ice cubes

1. Place all ingredients into blender jug.
2. Press 'SMOOTHIE' button.
3. Pour into 2 glasses.

Raspberry Citrus Smoothie

Serves 2

1 cup raspberry yogurt
1 cup frozen yogurt
1 cup orange juice
1 cup frozen raspberries

1. Place all ingredients into blender jug.
2. Press 'SMOOTHIE' button.
3. Pour into 2 glasses.

Peach Smoothie

Serves 2

400g can peaches in natural juice, drained
¼ cup plain yogurt
2 teaspoons honey
1 scoop vanilla ice-cream
1 cup milk

1. Place all ingredients into blender jug.
2. Press 'SMOOTHIE' button.
3. Pour into 2 glasses.

Mango Papaya Smoothie

Serves 2

1 mango, peeled, pitted, and chopped
½ small papaya, peeled, seeded, and chopped
1 cup plain yogurt
1 tablespoon fresh lime juice
1 tablespoon honey

1. Place all ingredients into blender jug.
2. Press 'SMOOTHIE' button.
3. Pour into 2 glasses.

Recipes – Thick Shakes

Tips for great Thick shakes

- Don't use hard ice cream straight from the freezer
- Leave ice cream out for about 5 minutes before blending; this time may vary depending on how cold your freezer is.
- Ice creams with a higher cream content may need a little extra milk.
- Always put ice cream in the blender jug in small pieces, never in large chunks as this may prevent the blender from blending in the allotted time.

Classic thick shake

Serves 2

270g chocolate ice cream
1/3 cup milk

1. Place all ingredients into blender jug.
2. Press the 'THICK SHAKE' button.
3. Pour into 2 glasses.

Berry Yogurt Thick shake

Serves 2

270g frozen berry yogurt
1/4 cup frozen mixed berries
1/2 cup milk

1. Place all ingredients into blender jug.
2. Press the 'THICK SHAKE' button.
3. Pour into 2 glasses.

Tim Tam Thick shake

Serves 2

4 Arnott's Original Tim Tams, roughly chopped
270g vanilla ice-cream
100ml milk
2 Tim Tam Fingers, to garnish

1. Place ingredients into blender jug.
2. Press the 'THICK SHAKE' button.
3. Pour into 2 glasses, garnish with Tim Tam Fingers.

Recipes – Cocktails

Sugar Syrup is an essential ingredient to making great cocktails. Use equal parts of white sugar and water and bring to the boil in a small saucepan until the sugar has dissolved. Cool and store in the refrigerator.

Frozen Lime Margarita

Serves 2

60ml tequila
30ml fresh lime juice
60ml Cointreau or triple sec
30ml sugar syrup
14 standard size ice cubes

1. Combine all ingredients in blender.
2. Press the 'COCKTAIL' button.
3. Pour into 2 cocktail glasses.

Strawberry Daiquiri

Serves 2

90ml Bacardi rum
60ml fresh lime juice
60ml sugar syrup
6 strawberries, quartered
14 standard size ice cubes

1. Combine all ingredients in blender.
2. Press the 'COCKTAIL' button.
3. Pour into 2 cocktail glasses.

Pina Colada

Serves 2

90ml Bacardi rum
120ml pineapple juice
60ml coconut cream
30ml Malibu
30ml sugar syrup
14 standard size ice cubes

1. Combine all ingredients in blender.
2. Press the 'COCKTAIL' button.
3. Pour into 2 cocktail glasses.

Splice

Serves 2

60ml Midori
60ml Malibu
120ml pineapple juice
80ml cream
14 standard size ice cubes

1. Combine all ingredients in blender.
2. Press the 'COCKTAIL' button.
3. Pour into 2 cocktail glasses.

Recipes – Cocktails (continued)

Mocha Madness

30ml espresso coffee
60ml Baileys
60ml vodka
1 scoop chocolate ice cream
14 standard ice cubes

1. Combine all ingredients in blender.
2. Press the 'COCKTAIL' button.
3. Pour into 2 cocktail glasses.

Eggnog

30ml sugar syrup
60ml brandy
60ml dark rum
2 eggs
8 standard size ice cubes
Milk

1. Combine all ingredients except milk in blender.
2. Press the 'COCKTAIL' button.
3. Pour into 2 cocktail glasses then top up glasses with milk.

Serves 2

Frozen Cosmopolitan

20ml citron vodka
40ml vodka
60ml Cointreau
120ml cranberry juice
1 teaspoon lime juice
8 standard size ice cubes

1. Combine all ingredients in blender.
2. Press the 'COCKTAIL' button.
3. Pour into 2 cocktail glasses.

Serves 2

Serves 2

Notes

12 Month Replacement Guarantee

We are so confident of the quality of our product, should this appliance develop any malfunction within 12 months of purchase (3 Months commercial use) due to faulty materials or manufacture, we will replace it for you absolutely free.

Should you experience any difficulties with your appliance, please phone our free call customer service line for advice on 1800 025 059 in Australia, or 0800 786 232 in New Zealand.

Alternatively, simply return the faulty appliance to your place of purchase, along with your purchase receipt.

Your Sunbeam 12 Month Replacement Guarantee naturally does not cover misuse or negligent handling, and excludes breakables such as glass or ceramic items, and normal wear and tear.

Similarly, your 12 Month Replacement Guarantee does not cover damage to household surfaces as a result of water or other substances leaking from your appliance, nor does it cover freight costs.

In Australia, this guarantee is additional to the conditions and guarantees which are mandatory as implied under the Trade Practices Act 1974 and State and Territory legislation.

Sunbeam Service Centres

Sunbeam has established a network of authorised service centres throughout Australia and New Zealand to provide quick, convenient service for our customers.

Should your appliance require repair or service, either during or after the guarantee period, contact your nearest service centre.

For a complete list of Sunbeam's authorised service centres:

Australia

www.sunbeam.com.au/service-centres
1800 025 059

New Zealand

www.sunbeam.co.nz/service-centres
0800 786 232

Consumer Hotline

In Australia

Visit www.sunbeam.com.au

Or Call 1800 025 059

In New Zealand

Visit www.sunbeam.co.nz

Or call 0800 786 232

 is a registered Trademark of Sunbeam.

'MultiBlender' is a trademark of Sunbeam Corporation.
Made in China. Designed and engineered in Australia.
Due to minor changes in design or otherwise,
the product may differ from the one shown in this leaflet.

© Copyright. Sunbeam Corporation Limited 2006.

ABN 45 000 006 771

Sunbeam Corporation is a division of GUD Holdings Ltd.