

**Stereo Radio
Cassette Recorder**

RX-FS470A

Operating Instructions

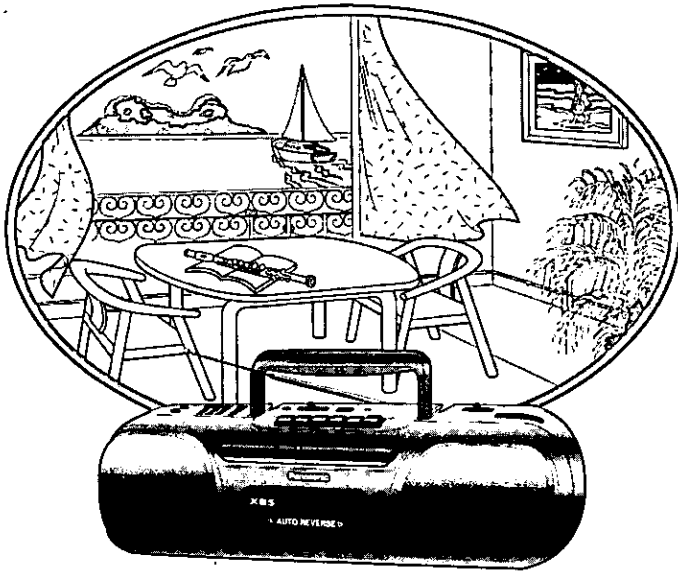

Panasonic®

Before connecting, operating or adjusting this product, please read these instructions completely. Please keep this manual for future reference.

Precautions

Before using this unit please read these operating instructions carefully. Take special care to follow the warnings indicated on the unit itself as well as the safety suggestions listed below.

Afterwards keep them handy for future reference.

Safety

- 1. Power Source**—The unit should be connected to power supply only of the type described in the operating instructions or as marked on the unit.
- 2. Polarization**—If the unit is equipped with a polarized AC power plug (a plug having one blade wider than the other), that plug will fit into the AC outlet only one way. This is a safety feature. If you are unable to insert the plug fully into the outlet, try reversing the plug. If the plug should still fail to fit, contact your electrician to replace your obsolete outlet. Do not defeat the safety purpose of the polarized plug.
- 3. Power Cord Protection**—AC power supply cords should be routed so that they are not likely to be walked on or pinched by items placed upon or against them. Never take hold of the plug or cord if your hand is wet, and always grasp the plug body when connecting or disconnecting it.
- 4. Nonuse Periods**—When the unit is not used, turn the power off. When left unused for a long period of time, the unit should be unplugged from the household AC outlet.

Installation

Environment

- 1. Water and Moisture**—Do not use this unit near water—for example, near a bathtub, washbowl, swimming pool, or the like. Damp basements should also be avoided.
- 2. Heat**—The unit should be situated away from heat sources such as radiators and the like. It also should not be placed in temperatures less than 5°C (41°F) or greater than 35°C (95°F).

Placement

- 1. Ventilation**—The unit should be situated so that its location or position does not interfere with its proper ventilation. Allow 10 cm (4") clearance from the rear of the unit.
- 2. Foreign Material**—Care should be taken so that objects do not fall into and liquids are not spilled into the unit. Do not subject this unit to excessive smoke, dust, mechanical vibration, or shock.
- 3. Magnetism**—The unit should be situated away from equipment or devices that generate strong magnetic fields.
- 4. Stacking**—Do not place heavy objects, other than system components, on top of the unit.
- 5. Surface**—Place the unit on a flat, level surface.
- 6. Carts and Stands**—The unit should be used only with a cart or stand that is recommended by the manufacturer. The unit and cart combination should be moved with care. Quick stops, excessive force, and uneven surfaces may cause the unit and cart combination to overturn.
- 7. Wall or Ceiling Mounting**—The unit should not be mounted to a wall or ceiling, unless specified in this operating instructions.



Maintenance

Clean the cabinet, panel and controls with a soft cloth lightly moistened with mild detergent solution.

Do not use any type of abrasive pad, scouring powder or solvent such as alcohol or benzene.

Service

- 1. Damage Requiring Service**—The unit should be serviced by qualified service personnel when:
 - (a) The AC power supply cord or the plug has been damaged; or
 - (b) Objects have fallen or liquid has been spilled into the unit; or
 - (c) The unit has been exposed to rain; or
 - (d) The unit does not appear to operate normally or exhibits a marked change in performance; or
 - (e) The unit has been dropped, or the enclosure damaged.
- 2. Servicing**—The user should not attempt to service the unit beyond that described in the operating instructions. All other servicing should be referred to an authorized service personnel.

*For the address of an authorized servicer:
in the U.S.A. 1-800-211-7262 or web site
(<http://www.panasonic.com>)*

Listening caution

Selecting fine audio equipment such as the unit you've just purchased is only the start of your musical enjoyment. Now it's time to consider how you can maximize the fun and excitement your equipment offers. This manufacturer and the Electronic Industries Association's Consumer Electronics Group want you to get the most out of your equipment by playing it at a safe level. One that lets the sound come through loud and clear without annoying blaring or distortion—and, most importantly, without affecting your sensitive hearing.

We recommend you to avoid prolonged exposure to excessive noise.

Sound can be deceiving. Over time your hearing "comfort level" adapts to higher volumes of sound. So what sounds "normal" can actually be loud and harmful to your hearing. Guard against this by setting your equipment at a safe level BEFORE your hearing adapts.

To establish a safe level:

- Start your volume control at a low setting.
- Slowly increase the sound until you can hear it comfortably and clearly, and without distortion.

Once you have established a comfortable sound level:

- Set the dial and leave it there.

Taking a minute to do this now will help to prevent hearing damage or loss in the future. After all, we want you listening for a lifetime.



Supplied accessories **A**

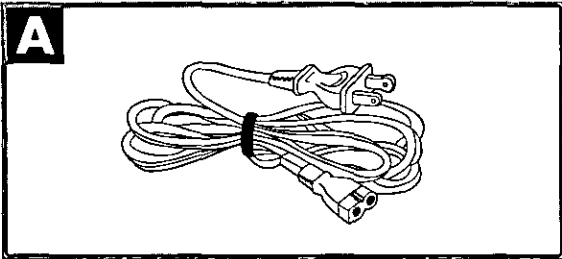

Please check and identify the supplied accessories. Use numbers indicated in parentheses when asking for replacement parts.
To order accessories contact 1-800-332-5368 or web site (<http://www.panasonic.com>).

AC power supply cord (polarized) 1 pc.
(RJA0065-A)

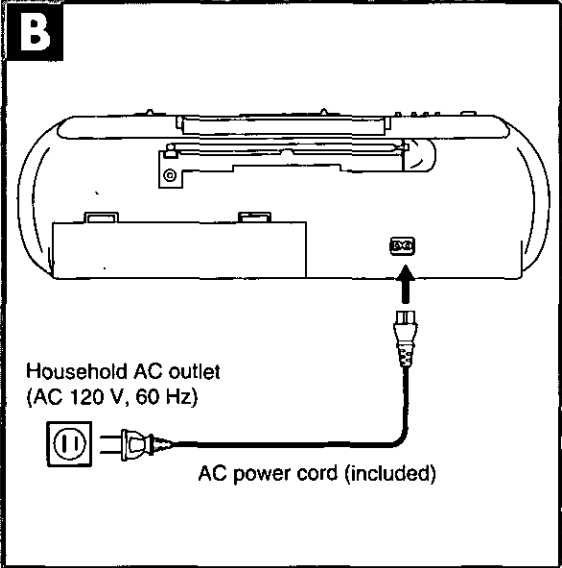

Power sources

The unit can be powered with household AC power or dry cell batteries (not included).

Using a household AC outlet **B**

Connect the power cord firmly to the unit and the outlet.

Notes

- Before unplugging the cord, set the [SELECTOR] to "TAPE/OFF". If the tape is travelling, press [STOP/EJECT] to stop the tape.
- If the unit is to be left unused for a long time, save power by turning the power off and unplugging the power cord from the power outlet.

Using batteries

The unit cannot be powered by batteries if the power cord is connected.

Battery installation and removal **C D**

When to replace the batteries

Sound quality and operation are affected when the batteries are running low. Replace all six batteries. It is also a good idea to replace all the batteries before recording.

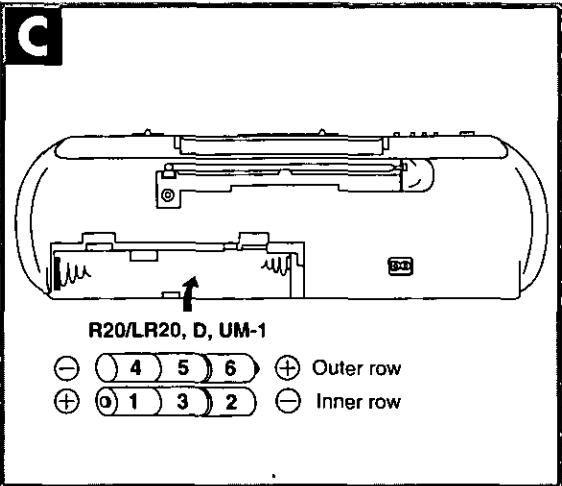

Use of batteries

- Align the poles (+ and -) properly when inserting the batteries.
- Do not mix old and new batteries or different types of batteries.
- Do not recharge ordinary dry cell batteries.
- Do not heat or disassemble the batteries. Do not allow them to contact flame or water.
- If the unit is not going to be used for a long time or if the unit is to be powered exclusively by AC power, remove the batteries and store them in a cool dark place.
- Do not keep together with metallic objects such as necklaces.
- Do not use rechargeable type batteries.

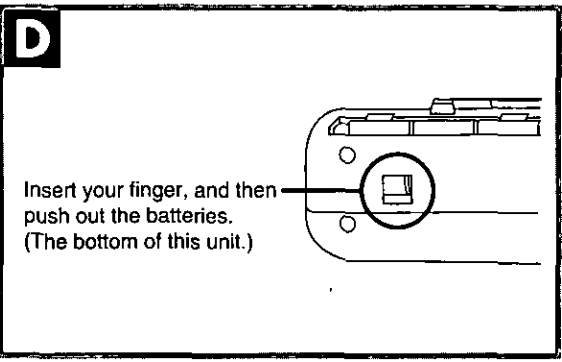

Mishandling of batteries can damage other items, cause damage to the unit, and may cause a fire through short-circuiting or electrolyte leakage.

If electrolyte leaks from the batteries, consult your dealer. Wash thoroughly with water if electrolyte comes in contact with any part of your body.

Location of controls **A**

- ① **Headphones jack (PHONES)**
- ② **Graphic equalizer level control (GRAPHIC EQUALIZER)**
The frequency response of the unit can be compensated for the room acoustics and other factors which affect the frequency response by adjusting the graphic equalizer controls. If XBS is set to "ON", the 100Hz control functions as an XBS level control.
- ③ **Built-in microphone (MIC)**
- ④ **Function selector (SELECTOR) (TAPE/⏏, RADIO, [CD]/LINE)**
- ⑤ **CD/line input jacks ([CD]/LINE IN)**
- ⑥ **FM stereo indicator (FM STEREO)**
- ⑦ **Band selector (BAND)**
- ⑧ **Tuning control (TUNING)**
- ⑨ **XBS on/off button (XBS)**
When XBS is set to "ON", the dynamic low frequency ranges are boosted. If XBS is used together with graphic equalizer, more dynamic sounds can be heard.
- ⑩ **Volume control (VOLUME)**
- ⑪ **Deck buttons:**
Pause button (⏸/PAUSE)
Stop/eject button (⏏/STOP/EJECT)
Fast forward/rewind button (⏩-FAST-⏪)
Playback button (◀/PLAY)
Record button (●/RECORD)
- ⑫ **Deck cassette compartment**
- ⑬ **Direction select lever (DIRECTION)**
- ⑭ **Reverse mode selector (REVERSE MODE)**
- ⑮ **Speaker (Woofer)**
- ⑯ **Speaker (Tweeter)**
- ⑰ **Handle**
- ⑱ **Telescopic antenna**
- ⑲ **Battery compartment**
- ⑳ **AC socket (AC IN ~)**

Using headphones **B**

Turn down the volume and connect the headphones to the [PHONES] jack.

Plug type: 3.5 mm (1/8") stereo

Note

Avoid listening for prolonged periods of time to prevent hearing damage.

Using external equipment **B**

When listening or recording CD, set [SELECTOR] to "[CD]/LINE".

Note

When not using the [CD]/LINE IN jacks, disconnect connector from it.

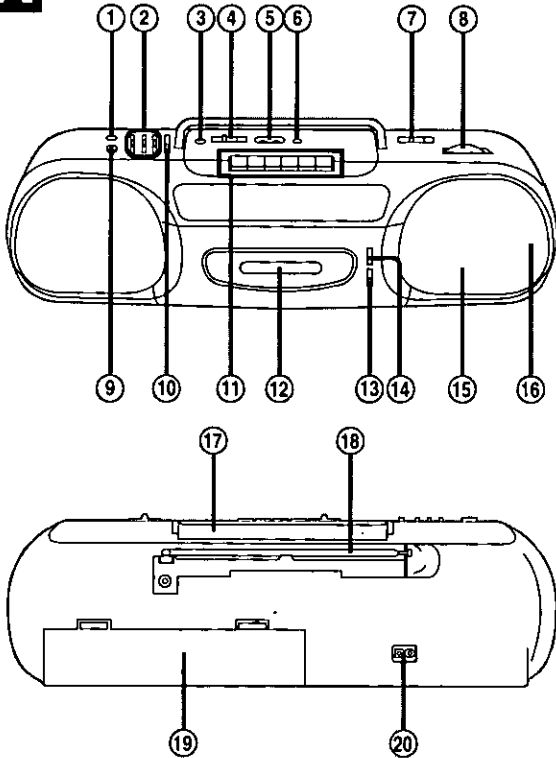
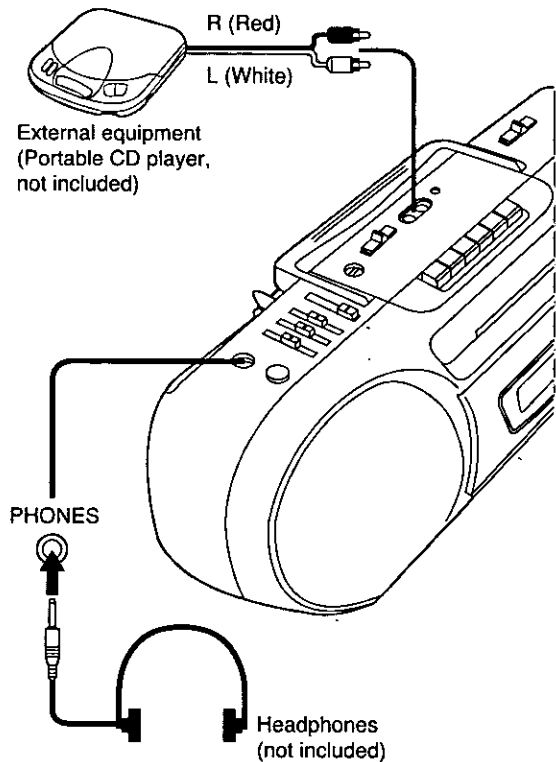
A**B**

Listening to radio broadcasts **A**

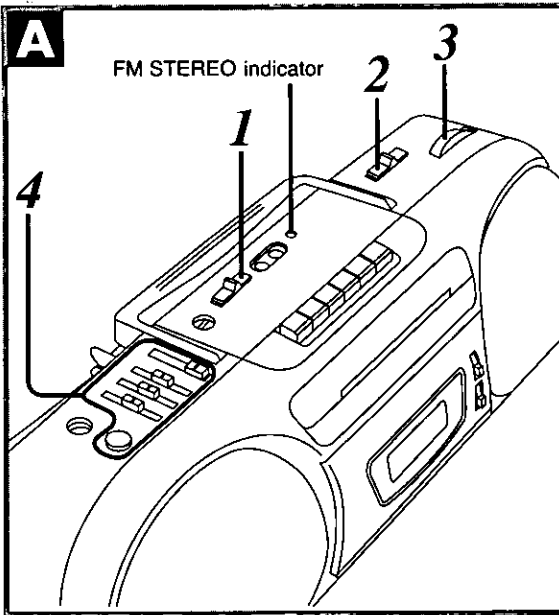

1 Set [SELECTOR] to "RADIO".



2 Set [BAND] to the desired radio band.

FM STEREO: To receive FM stereo broadcasts

(If you have tuned into an FM stereo broadcast, the FM STEREO indicator will light.)

AM: To receive AM broadcasts

- If FM stereo reception is poor, set [BAND] to "FM". This will reduce the noise and provide clear reception; however, the broadcast will not be heard in stereo.



3 Use [TUNING] to tune into a desired broadcast.

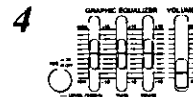

4 Adjust [VOLUME], [GRAPHIC EQUALIZER] and [XBS].

B

FM

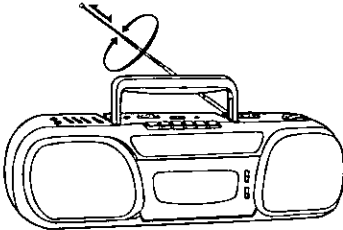

AM

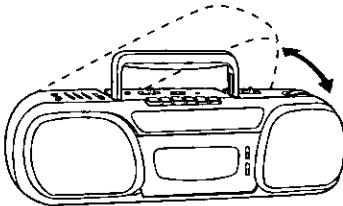

Adjusting the antenna **B**

FM:

Pull out the telescopic antenna and adjust its length and angle for optimum reception.

AM:

Turn the unit in the direction which gives the best results.

Reference:

Radio broadcasts may be hard to receive in a moving vehicle or in a building because the signal may be weakened. In such cases, use the unit near a window.

Listening to tapes **A**

This unit is suitable for playing normal tapes, but high and metal position tapes will not be played to their full potential.

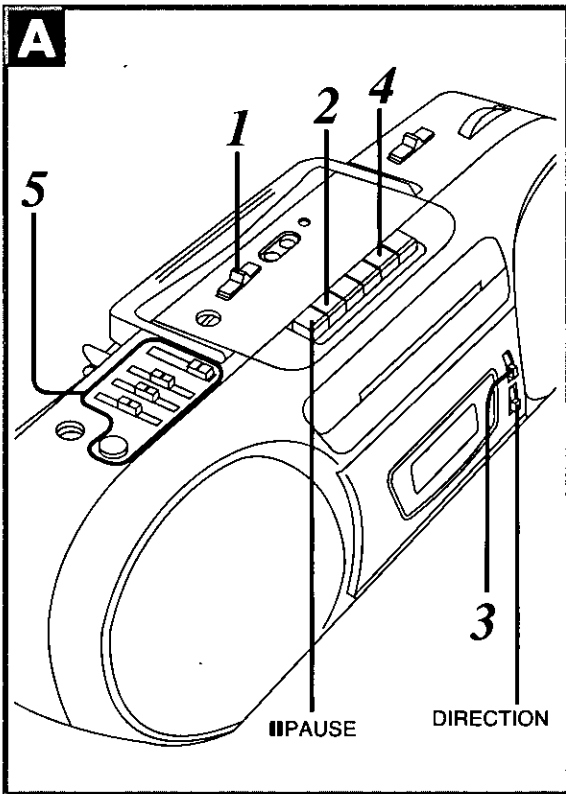

1  Set [SELECTOR] to "TAPE/**OFF**".

2  Press [**STOP/EJECT**], and then insert the tape.
Insert the cassette with the exposed tape facing up.

3  Set [REVERSE MODE] into the desired mode.
(See page 8.)

4  Press [**PLAY**] to start playback.

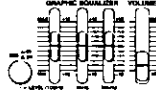
5  Adjust [VOLUME], [GRAPHIC EQUALIZER] and [XBS].

To reverse the playback side
Press [DIRECTION].

To stop the playback
Press [**STOP/EJECT**].

To briefly interrupt the playback
Press [**PAUSE**].

To resume playback, press [**PAUSE**] again.

B

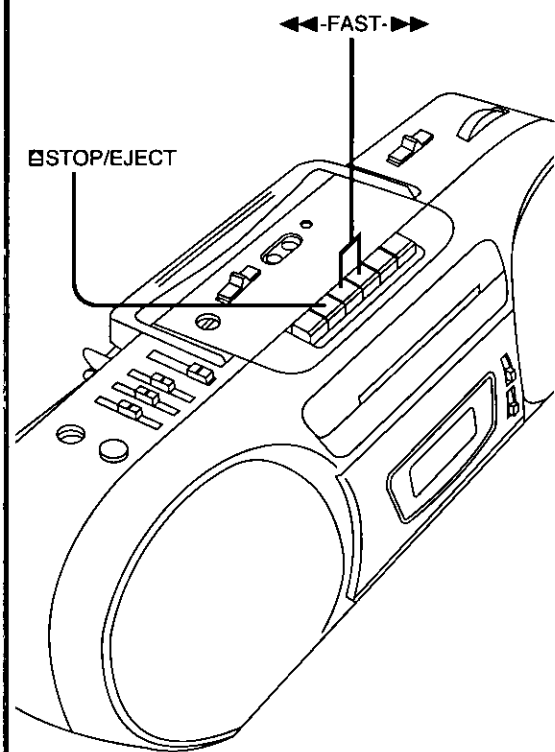

To fast forward or rewind the tape

B

Press [**◀◀-FAST▶▶**] while the tape is stopped.

Note

Do not press [**<PLAY**] during fast forward or rewind, as this may jam the tape.

Always press [**STOP/EJECT**] first, between functions.

Auto-Stop

The automatic stop system will release the buttons when the tape reaches the end during playback or recording.

During tape playback, if the reverse mode selector is set to "◁" position, the automatic stop system does not function.

Note

When the tape reaches the end by pressing the fast button, the automatic stop system does not function. The tape will stop, but the motor continues to turn. Do not leave the set in this condition. Be sure to press [**STOP/EJECT**] button.

Auto reverse system

This unit is equipped with an auto reverse function that allows you to perform two-side playback or repeat two-side playback.

To listen to forward side and reverse side with auto reverse

C

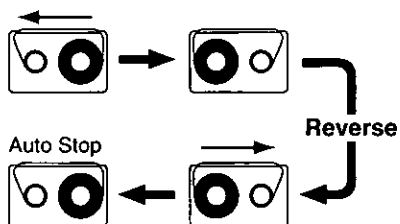

Two-side playback mode (↔)

Playback will start from the forward side to the reverse side and stops automatically.

To listen to forward side and reverse side repeatedly

D

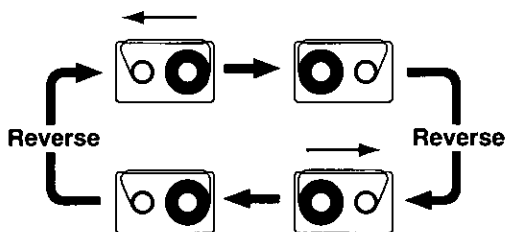

Repeat two-side playback mode (↻)

Playback will be repeated until the [**STOP/EJECT**] button is pressed.

Note

During playback in the reverse direction, if you press the [**STOP/EJECT**] button to stop the tape movement, and then press the playback button again, playback will begin always in the forward direction.



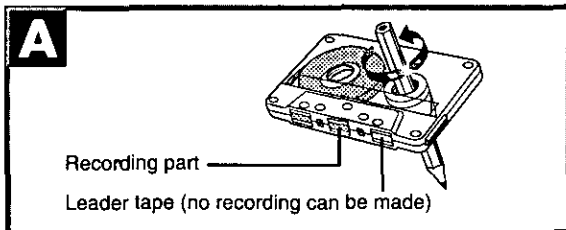

Making a recording

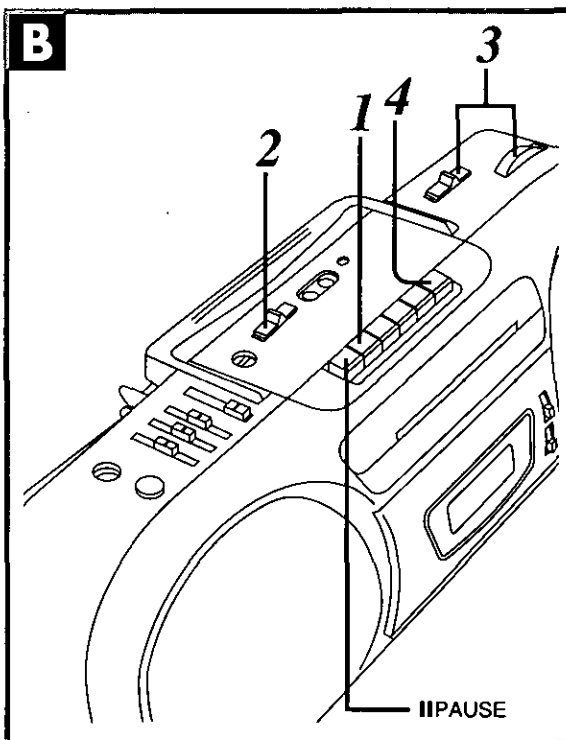

- This unit is suitable for recording normal tapes, but it cannot record onto high and metal position tapes to their full potential and prior recordings will not be erased.
- Any changes made to the volume or sound quality during recording will not affect the recording.
- The recording level is automatically adjusted.
- Auto reverse does not function during recording. Recording and erasure of recording can be made only in the forward direction.
- Recording cannot be made on the leader part of the tape. Before recording, wind the tape past the leader to a point where recording can start immediately. **A**



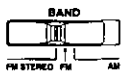

Recording from radio broadcasts **B**

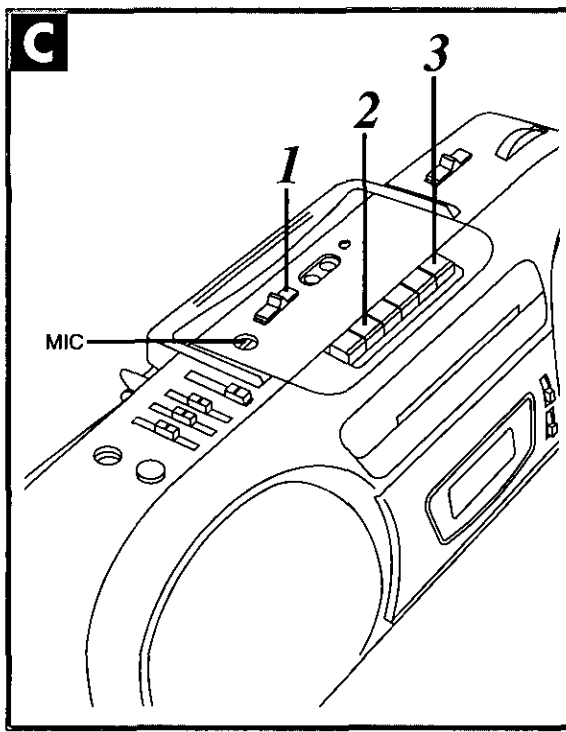
- 1**  Press [**STOP/EJECT**] to insert the tape.
- 2**  Set [**SELECTOR**] to "RADIO".
- 3**  Select the desired band.
 Tune into the desired broadcast.
- 4**  Press [**RECORD**].
[<PLAY] is also depressed with [**RECORD**]. Recording starts (one side only).



Recording through the built-in microphone **C**

- 1**  Set [**SELECTOR**] to "TAPE/**OFF**".
- 2**  Press [**STOP/EJECT**] to insert the tape.
- 3**  Press [**RECORD**].
[<PLAY] is also depressed with [**RECORD**]. Recording starts (one side only).

To stop the recording
Press [**STOP/EJECT**].

To briefly interrupt recording
Press [**PAUSE**].





To resume recording, press [**PAUSE**] again.

To record on the other side of the tape
Turn the tape over and press [**RECORD**].

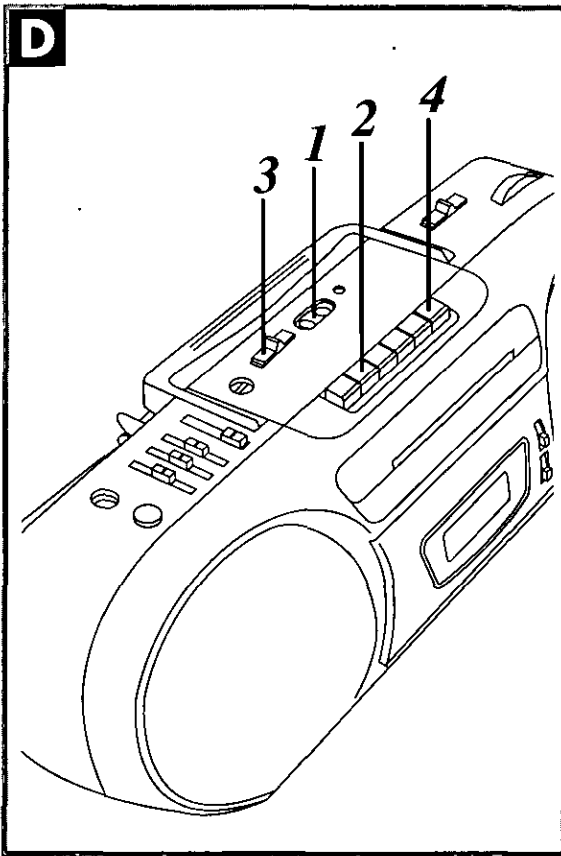
Making a recording

Recording from external equipment **D**

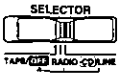



-  **1** **CD/LINE IN** Connect the output of the external equipment to **[CD/LINE IN]** jacks.
-  **2** **STOP/EJECT** Press **[STOP/EJECT]** to insert the tape.
-  **3** **SELECTOR** Set **[SELECTOR]** to "**CD/LINE**".
-  **4** **RECORD** Press **[RECORD]**. **[<PLAY]** is also depressed with **[RECORD]**. Recording starts (one side only).

Erasure of tape **E**

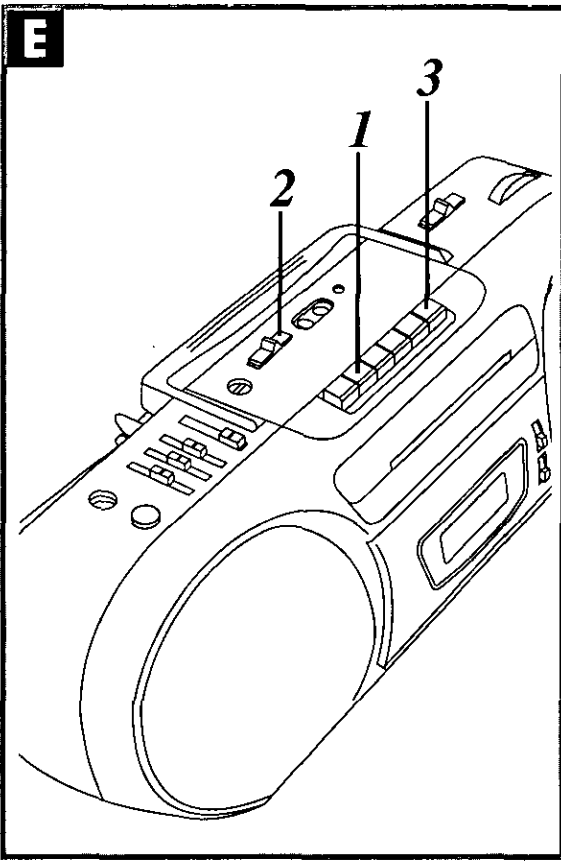
To erase a tape without re-recording, use the following procedure. (Make no connections to the **[CD/LINE IN]** jacks.)



-  **1** **STOP/EJECT** Press **[STOP/EJECT]** to insert the tape.
-  **2** **SELECTOR** Set **[SELECTOR]** to "**CD/LINE**".
-  **3** **RECORD** Press **[RECORD]**. **[<PLAY]** is also depressed with **[RECORD]**. Recording starts (one side only).

To stop the recording

Press **[STOP/EJECT]**.

To briefly interrupt recording

Press **[PAUSE]**.

To resume recording, press **[PAUSE]** again.

To record on the other side of the tape

Turn the tape over and press **[RECORD]**.

Concerning cassette tapes

A How to take up tape slack

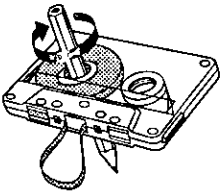

Use a pencil or similar object to take up the slack.

B To protect tapes against further recording

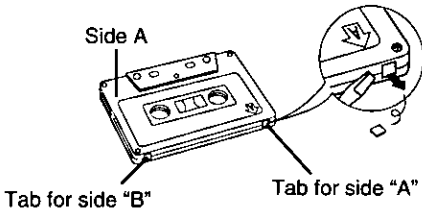

C To re-record

Normal position tape

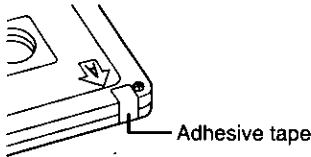

D

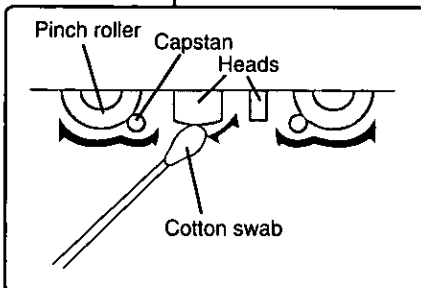
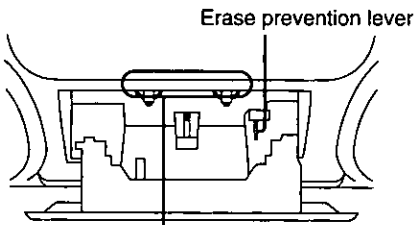

Selection of cassette tapes

Tapes can get caught on the capstans. Use caution with the following types of tapes.

Cassette tapes exceeding 100 minutes

Tapes are made of a thin film material. Do not repeatedly advance and stop the tape, fast-forward it or rewind it.

Endless-tapes

For this unit, it is recommended to use tapes which are appropriate to the auto reverse mechanism.

Always read the instructions provided with your tapes.

Tape slack

Tape slack may cause the tape to break.

Erase prevention

Use a screwdriver or similar object to break out the tab.

To re-record on a protected cassette, cover the hole with adhesive tape. **C**

Storage precautions

Do not place or store tapes in the following places:

- In high temperature (35°C or higher) or high humidity (80% or higher) areas
- In a strong magnetic field (near a speaker, on top of a TV, etc.) This can erase a recording.
- Locations exposed to direct sunlight

Maintenance

Cleaning inside the deck

Regularly clean the parts the tape contacts (the shaded portions in the illustration). Use alcohol only.

- ① Press [STOP/EJECT] to open the lid.
- ② Hold down the erase prevention lever and press [RECORD].
The mechanism will move out so it can be seen.
- ③ Clean the heads, pinch rollers and the capstans with a cotton swab dipped in alcohol.

Product service

Do not attempt to remove the cover(s) or repair the unit yourself. Refer servicing to qualified personnel only.

Product information

For product service, product information or assistance with product operation, refer to the servicenter directory.

Troubleshooting guide

If you are in doubt about some of the check points, or if the remedies indicated in the chart do not solve the problem, refer to the directory of Authorized Service Centers (enclosed with this unit) to locate a convenient service center, or consult your dealer for instructions.

For detailed instructions, contact an authorized servicenter in the U.S.A..

In the U.S.A. 1-800-211-7262 or web site (<http://www.panasonic.com>)

Common problems	
The unit doesn't work on batteries.	Are the batteries run down? Replace them with new ones.
	Is the AC power cord connected to the unit? Disconnect when using batteries.
	Have the batteries been inserted correctly? Check that the poles (- and +) are correctly aligned.
While listening to tapes	
Recording not possible.	Has the cassette's tab been removed? Cover the hole with tape.
Poor sound quality.	Clean the heads.
While listening to the radio	
A lot of noise.	Is another remote control being used? Use it further away from this unit.
	Is the TV on? Move the unit away from the TV or turn it off.

Technical specifications

Radio

Frequency range

FM

88 - 108 MHz

AM

525 - 1705 kHz

Tape recorder

Track system

4 track, 2 channel, stereo

Recording system

AC bias, magnet erase

Monitor system

Variable sound monitor

Frequency range

70 - 11000 Hz (Normal)

General

Power requirement

AC

120 V, 60 Hz

Battery

Power consumption: 12 W
9 V (six "D" size batteries)

Speakers

2 Woofers: 10 cm
2 Tweeters: 1.5 cm

Jacks

Input

CD/LINE IN: 316 mV/47 kΩ

Output

HEADPHONES: 32 Ω

Dimensions (WxHxD)

460 x 149 x 151 mm
(18¹/₈" x 5⁷/₈" x 5¹⁵/₁₆")

Weight

2.4 kg without batteries
(5 lb. 5 oz.)

Note

Specifications are subject to change without notice.
Weight and dimensions are approximate.

Panasonic Consumer Electronics Company, Division of Matsushita Electric Corporation of America

One Panasonic Way Secaucus,
New Jersey 07094

<http://www.panasonic.com>

Panasonic Sales Company, Division of Matsushita Electric of Puerto Rico, Inc. ("PSC")

Ave. 65 de Infanteria, Km. 9.5
San Gabriel Industrial Park, Carolina,
Puerto Rico 00985



RQT5100-P
P0399Y0(M)