

OLYMPUS®

DIGITAL VOICE
RECORDER

DS-3000

ONLINE
INSTRUCTIONS

Please read these instructions for information about using
the product correctly and safely.

Keep the instructions handy for future reference.

To ensure successful recordings, we recommend that
you test the record function and volume before use.

For Safe And Correct Usage

Thank you for purchasing the Olympus Digital Voice Recorder DS-3000. Before using your new recorder, read this manual carefully to ensure that you know how to operate it safely and correctly. Keep this manual in an easily accessible location for future reference.

- The warning symbols indicate important safety related information. To protect yourself and others from personal injury or damage to property, it is essential that you always heed the warnings and information provided.

General Precautions

- Do not leave the recorder in hot, humid locations such as inside a closed automobile under direct sunlight or on the beach in the summer.
- Do not store the recorder in places exposed to excessive moisture or dust.
- Do not use organic solvents such as alcohol and lacquer thinner to clean the unit.
- Do not place the recorder on top of or near electric appliances such as TVs or refrigerators.
- Avoid sand or dirt. These can cause irreparable damage.
- Avoid strong vibrations or shocks.
- Do not disassemble, repair or modify the unit yourself.
- Do not operate the unit while operating a vehicle (such as a bicycle, motorcycle, or go-cart).
- Keep the unit out of the reach of children.

IBM, PC/AT and ViaVoice are the trademarks or registered trademarks of International Business Machines Corporation.

Microsoft and Windows are registered trademarks of Microsoft Corporation.

Intel and Pentium are registered trademarks of Intel Corporation.

Macintosh and Apple are registered trademarks of Apple Computer, Inc.

Other product and brand names mentioned herein may be the trademarks or registered trademarks of their respective owners.

Batteries

Warning

- Batteries should never be exposed to flame, heated, short-circuited or disassembled.
- Do not attempt to recharge alkaline, lithium or any other non-rechargeable batteries.
- Never use any battery with a torn or cracked outer cover.
- Keep batteries out of the reach of children.
- If you notice anything unusual when using this product such as abnormal noise, heat, smoke, or a burning odor:
 - ① remove the batteries immediately while being careful not to burn yourself, and;
 - ② call your dealer or local Olympus representative for servicing.

AC Adapter

Warning

- Do not attempt to disassemble, repair or modify the AC adapter in any way.
- Keep objects including water, metal, or flammable substances from getting inside the product.
- Do not moisten the AC adapter or touch it with a wet hand.
- Do not use the AC adapter in the vicinity of flammable gas (including gasoline, benzene and lacquer thinner).

In case

- ...the internal parts of the AC adapter are exposed because it has been dropped or otherwise damaged:
- ...the AC adapter is dropped in water, or if water, metal flammable substances or other foreign objects get inside it:
- ...you notice anything unusual when using the AC adapter such as abnormal noise, heat, smoke, or a burning odor:
 - ① do not touch any of the exposed parts
 - ② immediately disconnect the power supply plug from the power outlet, and
 - ③ call your dealer or local Olympus representative for servicing. Continued use of the AC adapter under these circumstances could result in electric shock, fire or injury.

Main Features

- The DS-3000 digital voice recorder stores highly compressed DSS audio files on SmartMedia cards.
- The DS-3000 supports two recording modes: SP (Standard Playback) mode and LP (Long Playback) mode (→ P.22). The supplied 16MB SmartMedia card can store approximately 2 hours and 35 minutes of recordings* in SP mode and approximately 5 hours and 30 minutes* in LP mode. A 64MB SmartMedia card (sold separately) can hold up to 22 hours and 20 minutes* of recordings.
- The Variable Control Voice Actuator (VCVA) saves memory space by pausing recording when the recorder judges that there is no sound (→ P.30).
- Recorded audio files can be stored in three separate folders for easier identification in future use.
- Overwrite recording, insert recording, additional recording and partial erasure functions make it easy to correct and edit recordings.
- Furthermore, the AS-3000 transcription kit (sold separately) provides you with a PC-footswitch and DSS Player Pro Transcription Module for easy transcription of DSS recordings.

* The recording time available may be shorter than specified if a large number of short recordings are made. (Use the remaining time and recorded time only as references.)

Table of Contents

Getting Started

SmartMedia	6	Identification of Parts	8
------------------	---	-------------------------------	---

Preparing For Recording

Inserting Batteries	10	Setting Time/Date	12
Replacing Batteries	11	Inserting and Ejecting SmartMedia cards	14
Using the AC Adapter	11		

Basic operations

Recording	16	Playing	23
Microphone Sensitivity	21	Erasing	26
Recording Modes	22		

Other functions

Using the Variable Control Voice Actuator (VCVA)	30	Moving Files Across Folders	36
Locking Files	31	Assigning Folder Names	38
Index Marks	32	Setting Priority Levels	40
System Sounds	33	Setting Job Data	42
Alarm Playback Function	34	Formatting SmartMedia	46
		Transferring Data to a PC	47

Other Information

Dealer Option Items	48	Alarm Message List	51
Hold	48	Troubleshooting	52
Reset	48	Specifications	53
Training your PC for Voice Recognition ...	49	Accessories (optional)	54
Menu List	50	Technical Assistance And Support	55

SmartMedia

What is SmartMedia?

SmartMedia is a type of removable IC memory card. With more memory than a floppy disk, SmartMedia cards facilitate data exchange with personal computers, and can be used to store data. Optional SmartMedia cards are available to add capacity as needed, in addition to the included 16MB SmartMedia card.

When purchasing SmartMedia cards of various memory capacities, specify 3 V (3.3 V) SmartMedia cards (in memory sizes of 4, 8, 16, 32, and 64MB) for the Olympus CAMEDIA digital camera series.

Notes

- Commercial 5 V SmartMedia cards cannot be used.
- This product is compatible with SmartMedia cards that have the copyright protection ID feature, and with SmartMedia cards without the ID feature. (Audio files recorded with this product are not protected by copyright law.)
- Never use SmartMedia cards with products that are not compliant with the SSFDC Forum* (including certain models of MP3 players).

* The SSFDC Forum is a voluntary organization committed to promoting SmartMedia as a de facto standard in the industry. The DS-3000 adheres to a format recommended by the SSFDC Forum.

Memory Sizes of SmartMedia Cards and Approximate Recording Times*

Memory Size	SP Mode	LP Mode
4MB	35 min.	1 hr.20 min.
8MB	1 hr.15 min.	2 hr.45 min.
16MB	2 hr.35 min.	5 hr.30 min.
32MB	5 hr.10 min.	11 hr.10 min.
64MB	10 hr.25 min.	22 hr.20 min.

* Recording time is calculated using a single audio file recorded continuously. If audio files are recorded intermittently, recording time may be shorter than indicated.

Audio Recording Format

The DS-3000 stores highly compressed DSS (Digital Speech Standard) audio files on SmartMedia cards.

Write-protect SmartMedia

A write-protect seal (supplied with SmartMedia card) can be attached to a SmartMedia card to guard against accidental recording, erasing, and formatting.

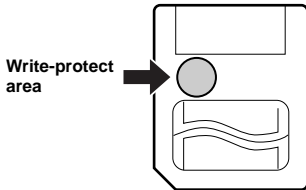

Attach the write-protect seal to the write-protect area to prevent valuable data from being erased accidentally.

Remove the write-protect seal before recording or erasing.

Notes

- Attach the write-protect seal to the write-protect area carefully, without letting the seal stick out, lift, or peel.
- Do not use commercial seals.
- Write-protect seals cannot be reused.
- A dirty write-protect seal may disable the write-protect feature. Wipe it with a soft, dry cloth.
- A SmartMedia card with a write-protect seal attached to it may not be write-protected when using the card with other products.

Identification of Parts

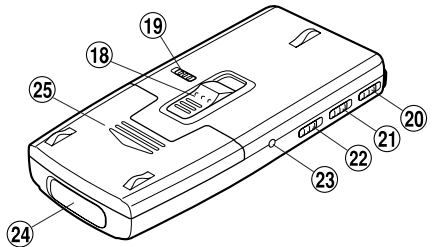
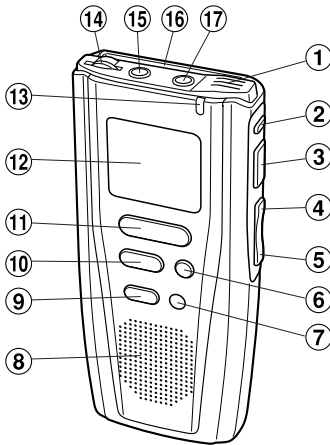

- ① Built-in microphone
- ② NEW button
- ③ REC (Record) /SET button
- ④ REW (Rewind) /- button
- ⑤ FF (Fast Forward) /+ button
- ⑥ INDEX button
- ⑦ ERASE button
- ⑧ Built-in speaker
- ⑨ FOLDER/MENU button
- ⑩ STOP button
- ⑪ PLAY button
- ⑫ Display (LCD panel)
- ⑬ Record/Play indicator lamp

- ⑭ VOLUME control
- ⑮ Earphone jack
- ⑯ SmartMedia slot
- ⑰ Microphone jack
- ⑱ SmartMedia ejection switch
- ⑲ POWER/LOCK switch
- ⑳ MICSENS (Microphone sensitivity) switch
- ㉑ VCVA switch
- ㉒ HOLD switch
- ㉓ Power jack
- ㉔ PC (USB) terminal
- ㉕ Battery cover

Display (LCD Panel)

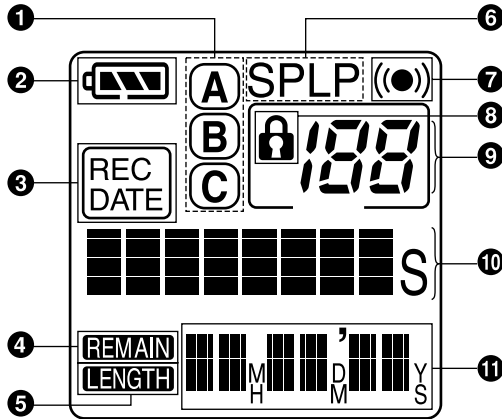

- ❶ Folder
- ❷ Battery indicator
- ❸ Recording date/time mark
- ❹ Remaining memory mark
- ❺ Total file time mark
- ❻ Record mode
- ❼ Alarm mark
- ❽ Erase lock mark
- ❾ Current file
- ❿ Current time, elapsed time, recording time, operation guides, menu display, etc.
- ⓫ Date, remaining memory, total recording time of the playing file, operation guides, etc.

Stopped State

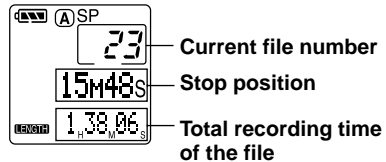

The display appears as shown below when recording or playback is stopped.

Inserting Batteries

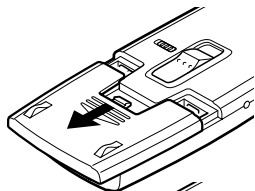

1 Slide open the battery cover.

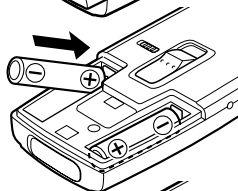

2 Insert two AAA alkaline batteries, observing the correct polarity.

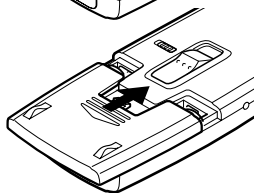

3 Close the battery cover completely.

.....

Note

The hour indicator will flash automatically when you insert batteries before using the recorder for the first time, or after the recorder hasn't been used for a long time. Adjust the time by following Steps 1 to 2 in "Setting Time/Date" (→ P.12, 13).

Replacing Batteries

The battery indicator on the display changes as the batteries lose power.

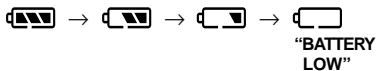

When the batteries are too weak, the recorder shuts down and "BATTERY LOW" appears on the display.

When  appears on the display, replace the batteries as soon as possible. AAA alkaline batteries* are recommended.

* The two AAA alkaline batteries provide approximately 11 hours of continuous recording and playback. Battery life depends on the operating environment and other conditions.

Using the AC Adapter

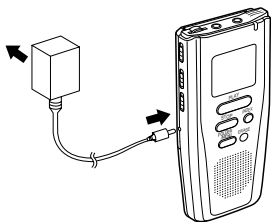

Plug the optional AC adapter (Olympus Model A321 or A322) into household power outlet and connect the power plug to the recorder's power connector (DC 3 V) as shown in the illustration. Do not connect the AC adapter to the recorder during recording. Always stop recording before connection. Otherwise it may not be possible to play back the voice data being recorded.

Notes

- **Be sure to stop the recorder before replacing the batteries.** Unloading the batteries while the recorder is recording, erasing or otherwise accessing an audio file may corrupt the file.
- Be sure to replace both batteries at the same time.
- **Never mix old and new batteries, or batteries of different types and/or brands.**
- If it takes longer than 3 minutes to replace dead batteries, you may have to reset the time when you load fresh batteries.
- Remove the batteries if you are not going to use the recorder for an extended period of time.

Setting Time/Date

If you have set the time and date, information as to when an audio file is recorded is stored automatically with that file. The time and date should be set to ease audio file management tasks. The time and date setting is also needed to perform the alarm playback function (→ P.34, 35). The hour indicator will flash automatically when you load batteries before using the recorder for the first time, or after the recorder hasn't been used for a long time. To adjust the time, follow the steps described below.

Time/Date Setup Screen

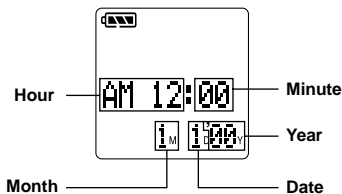

1 Repeat steps ① and ② to set the time and date:

Time and date setup proceeds in the order of hour, minute, year, month, and date.

- ① Press the FF/+ button or REW/- button to set a value.
- ② Press the REC/SET button to accept the value.

2 Press the STOP button to end.

This completes the time setup procedure.

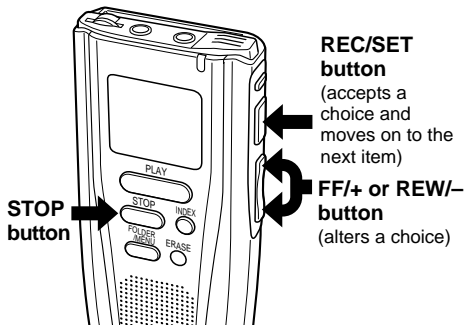

Notes

- If you press the STOP button during the setup operation, the clock will use the items that were set to that point.
- Each press of the NEW button during setting toggles the display between the 12-hour and 24-hour system.

Change Time/Date

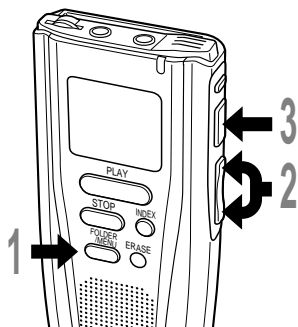

- 1 Press the FOLDER/MENU button for 1 second or longer.**
The menu opens (→P.50).
- 2 Press the FF/+ or REW/- button to choose the time/date setup screen.**
- 3 Press the REC/SET button.**
The hour indicator flashes, indicating the start of the time/date setup process.

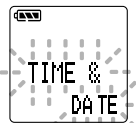

Start with Step 1 and follow the rest of the time/date setup procedure (→ P.12).

Inserting and Ejecting SmartMedia cards

Inserting SmartMedia cards

Insert the SmartMedia card into the slot as shown below.

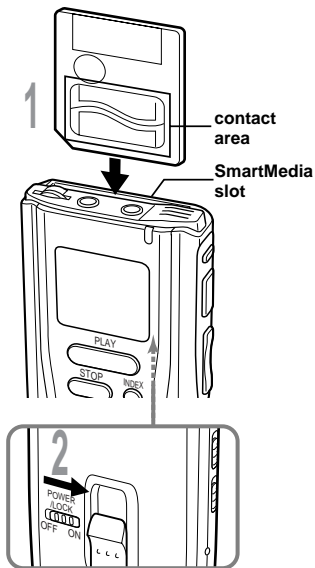

1 Insert the SmartMedia in the correct direction.
Push the SmartMedia card fully into position.

2 Set the POWER/LOCK switch to ON.
The display appears.

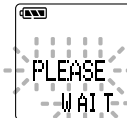

When the SmartMedia card is inserted properly, "PLEASE WAIT" flashes on the display.

Notes

- If an unformatted SmartMedia card is inserted, "FORMAT YES?" will display automatically. Format the SmartMedia card (→ P.46).
- Never use any SmartMedia card other than one that has been formatted on this unit or on a CAMEDIA series Olympus digital camera (→ P.6).

SmartMedia inserted fully into the slot

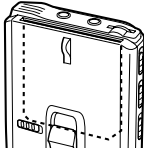

When you set the POWER/LOCK switch to the ON position, "PLEASE WAIT" flashes on the display.

SmartMedia not inserted fully into the slot

Bottom side of SmartMedia projecting from the slot

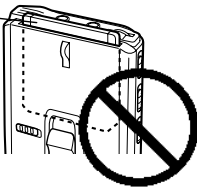

When you set the POWER/LOCK switch to the ON position, "INSERT CARD" flashes on the display for 2 seconds. Pressing any button with no SmartMedia card inserted causes "INSERT CARD" to appear again. Push the SmartMedia card fully into position.

Ejecting SmartMedia cards

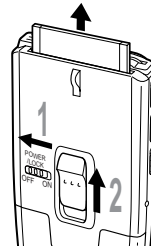

- 1 **Set the POWER/LOCK switch to OFF.**
The display disappears.
- 2 **Raise the SmartMedia ejection switch.**
Pull the SmartMedia card out with your fingers.

The SmartMedia ejection switch won't work if the POWER/LOCK switch is set to ON.

Attention

- SmartMedia cards are precision devices. Never force the cards when inserting them, or subject them to sharp blows.
- Avoid handling and storing SmartMedia cards in a hot, damp environment.
- Do not touch the contact area (gold electrodes) of the SmartMedia card with bare hands. If a SmartMedia card gets dirty, wipe it with a soft, dry cloth.
- SmartMedia cards may be vulnerable to electrostatic data corruption. When carrying a SmartMedia card, put it in its case. Remember to back up data from SmartMedia cards to a PC or other storage medium from time to time (→ P.47).
- Corrupted, lost, or erased data cannot be restored.

Recording

The recorder provides three folders, **[A]**, **[B]**, and **[C]**, and each message recorded in a folder is saved as a Digital Speech Standard (DSS) file. These three folders can be selectively used to distinguish the kind of recording; for example, folder **[A]** might be used to store private information, while folder **[B]** might be dedicated to holding business information (→ P.38, 39). Up to 199 messages can be recorded per folder. Four recording modes are available: new, append, overwrite, and insert.

New Recording

Create a new file to record in.

Recording

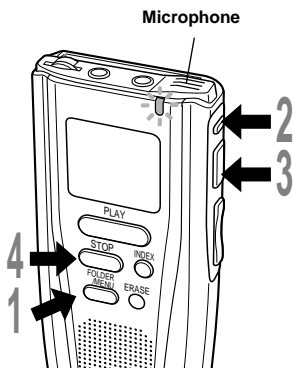

1 Press the FOLDER/MENU button to choose a folder.

The folder name is displayed for 2 seconds.

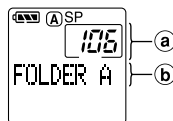

- a Current file number
- b Folder name

2 Press the NEW button to create a new file.

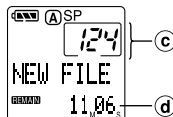

- c New file number
- d Remaining recording time

3 Press the REC/SET button to start recording.

The record/play indicator lamp glows red. Aim the microphone at the sound source.

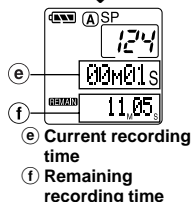
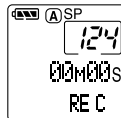

- e Current recording time
- f Remaining recording time

4 Press the STOP button to stop recording.

Notes

- If you press the PLAY button during recording, recording will stop, and play will start at the beginning of the file to which you were recording.
- If you press the NEW button during recording, recording will stop, and "NEW FILE" will appear on the display (as in Step 2).
- A beep will sound when remaining recording time reaches 60 seconds, 30 seconds, and 10 seconds while recording.
- While recording is in progress, never disconnect or connect the AC adapter even if the recorder contains batteries. This may result in failure to play the recorded file.

Pause Recording

Pause

Press the REC/SET button while recording.

➡ "REC PAUSE" will flash on the display.

Resume Recording

Press the REC/SET button again.

➡ Recording will resume at the point of interruption.

Note

The recorder stops when it has been left paused for 10 minutes or longer.

To instantly review a recording (Quick review)

Press the REW/- button while recording, and release it when you want to start playing a file.

The recorder plays up to the quick review point, then stops.

You can append additional recording in the same file from that point.

Listening While Audio Is Recorded (Recording Monitor)

Insert the earphone into the earphone jack to monitor what is being recorded. (The volume is fixed.).

Append recording

Perform the procedure of "New Recording", then press the REC/SET button once again to append additional recording to the same file.

Note

You cannot select any recording mode other than that of the original file before append recording (→ P.22).

Overwrite Recording

You can overwrite a previously recorded file from any point within the file. Note that the overwritten recording will be erased.

Recording

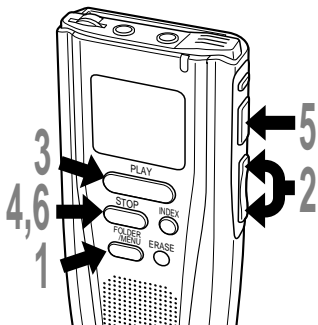

1 Press the **FOLDER/MENU** button to choose a folder.

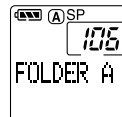

2 Press the **FF/+** or **REW/-** button several times to choose the file into which you want to overwrite. See "To fast-forward," "To skip," and "To rewind" on page 24.

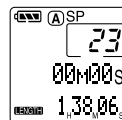

3 Press the **PLAY** button to play the file.

4 Press the **STOP** button where you want to start overwriting.

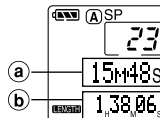

- a** Current playback time
- b** Total recording time of the file being played

5 Press the **REC/SET** button to start overwriting. The Record/Play indicator lamp glows red.

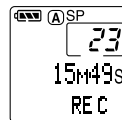

6 Press the **STOP** button to stop overwriting.

Notes

- When you are overwriting and reach the end of the file, the recorder begins to append the additional recording.
- Append recording does not erase the next previously recorded file.
- Locked files cannot be overwritten (→ P.31).
- A SmartMedia card with a write-protect seal attached to it cannot be overwritten.
- You cannot select any recording mode other than that of the original file before overwrite recording (→ P.22).

Inserting Recording into Previous Files

Additional recording can be inserted into previously recorded files.

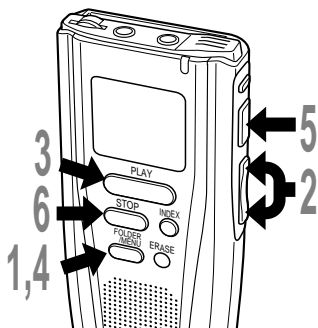

1 Press the FOLDER/MENU button to choose a folder.

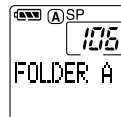

2 Press the FF/+ or REW/- button several times to choose the file into which you want to insert additional recording.

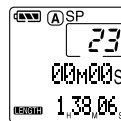

See "To fast-forward," "To skip," and "To rewind" on page 24.

3 Press the PLAY button to play the file.

4 While playing a file, press the FOLDER/MENU button if you want to insert additional recording.

"INSERT REC?" appears on the display.



5 Press the REC/SET button to start inserting additional recording.

As insert recording progresses, remaining memory grows smaller.

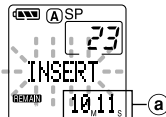

a Remaining recording time

6 Press the STOP button to stop inserting additional recording.

Microphone Sensitivity

Microphone sensitivity is adjustable to meet recording needs.

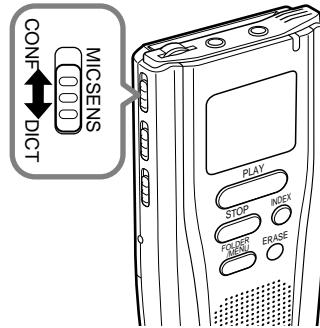

Using the MICSSENS switch, choose between the CONF and DICT positions.

CONF : High-sensitivity mode that records sounds in all directions.

DICT : Low-sensitivity mode suited for dictation.

Notes

- An optional ME7 conference microphone is recommended for recording conferences in CONF mode if people speaking are located far away from the recorder.
- Choose DICT mode if you want to use voice-recognition software, such as ViaVoice from IBM.

Pause Insert Recording

Pause

Press the REC/SET button.

➡ “INSERT PAUSE” flashes on the display.

Resume Insert Recording

Press the REC/SET button again.

➡ Insert recording resumes.

Notes

- The recording time and date of the file into which recording has been inserted is updated to the time and date of when the inserted recording was recorded.
- You cannot select any recording mode other than that of the original file before insert recording (→ P.22).

Recording Modes

You can choose between two recording modes: SP (Standard Playback) mode and LP (Long Playback) mode. Once you choose a mode, files are recorded in the selected mode as long as you do not change the mode.

The included 16MB SmartMedia card holds approximately 2 hours and 35 minutes in SP mode and approximately 5 hours and 30 minutes in LP mode.

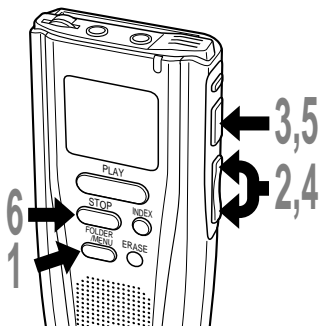

- 1 Press the FOLDER/MENU button for 1 second or longer.**

The menu opens (→ P.50).

- 2 Press the FF/+ or REW/- button to open the Recording Mode Setup screen.**



- 3 Press the REC/SET button.**
The recording mode setup process begins.



- 4 Press the FF/+ or REW/- button to choose between SP and LP.**

- 5 Press the REC/SET button.**
The recording mode setup process ends.

- 6 Press the STOP button to close the menu.**

Notes

- Choose SP mode for recording meetings or lectures with crisp clarity.
- Choose SP mode if you want use voice-recognition software, such as ViaVoice from IBM.
- You cannot select any recording mode other than that of the original file before append, overwrite, or insert recording.

Playing

You can start playing a file at any point. The recorder stops automatically when it finishes playing each file.

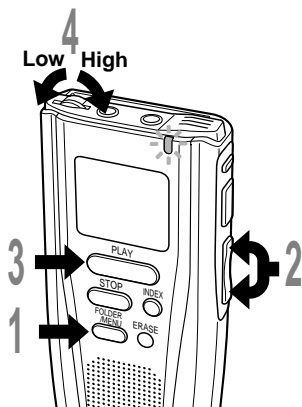

1 Press the FOLDER/MENU button to choose a folder.

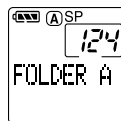

2 Press the FF/+ or REW/- button several times to choose the file that you want to play.

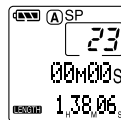

See "To fast-forward," "To skip," and "To rewind" on page 24.
The time and date when the file was recorded are displayed.

3 Press the PLAY button to start playback.

The record/play indicator lamp glows green.

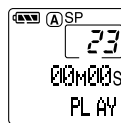

4 Adjust the VOLUME control to your liking.

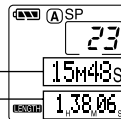

- (a) Current playback time
- (b) Total recording time of the file being played

Canceling Playback

Stop

Press the STOP button.

- The playback stops at the point where the STOP button was pressed.
- Press the PLAY button to resume the playback.

Pause

Press the PLAY button.

- “PLAY PAUSE” flashes on the display.

Resume Playback

Press the PLAY button again.

- Playback will resume at the point of interruption.

Note

The recorder stops when it has been left paused for 10 minutes or longer.

Playback Functions

To fast-forward

Press the FF/+ button once while stopped.

- The recorder stops at the end of the file.
- Press the FF/+ button once while playing a file to start playing from the beginning of the next file (or index mark).

To skip

Press the FF/+ button once while fast-forwarding.

or

Press the FF/+ button twice while stopped.

- The recorder skips to and stops at the beginning of the next file and displays the recording time and date.

To skip continuously

Continue pressing the FF/+ button while fast-forwarding.

To rewind

Press the REW/- button once while stopped.

- The recorder stops at the beginning of the file.
- Press the REW/- button once while playing a file to start playing from the beginning of the previous file (or index mark).

To skip backward

Press the REW/- button once while rewinding.
or

Press the REW/- button twice while stopped.

- ➡ The recorder skips to and stops at the beginning of the previous file and displays the recording time and date.

To continuously skip backward

Continue pressing the REW/- button while rewinding.

Fast Playback

Hold the PLAY button for 1 second or longer while playing a file.

- ➡ The recorder plays back at approximately 50% faster than normal rate.
- After fast playback is canceled, playback returns to normal rate.

Canceling Fast Playback

Hold the PLAY button for 1 second or longer again*.

- ➡ Playback returns to normal rate.
- * Press the PLAY button momentarily (for less than 1 second) to pause with fast playback enabled.

Cue (Fast Forward While Playing)

Hold the FF/+ button while playing a file.

- The recorder stops when it reaches the end of the file. Continue pressing the FF/+ button to proceed with the cue from the beginning of the next file.
- If an index mark is encountered in the middle of the file, the recorder stops at that point, the index number flashes momentarily, and then cueing proceeds when the FF/+ button is still pressed.

Canceling a Cue

Release the FF/+ button where you want the file played.

- ➡ Playback begins.

Review (Fast Rewind While Playing)

Hold the REW/- button while playing a file.

- The recorder stops when it reaches the beginning of the file. Continue pressing the REW/- button to proceed with the review from the end of the next file.
- If an index mark is encountered in the middle of the file, the recorder stops at that point, but will proceed with the review if the REW/- button is pressed.

Canceling the Review

Release the REW/- button where you want the file played.

- ➡ Playback begins.

Erasing

Erasing One File at a Time

A selected file can be erased from a folder.

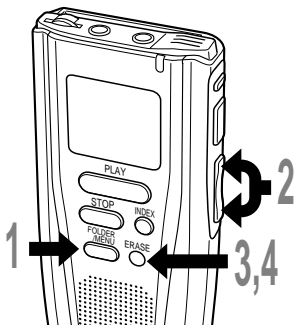

1 Press the **FOLDER/MENU** button to choose a folder.

2 Press the **FF/+** or **REW/-** button several times to choose the file you want to erase.

See “To fast-forward,” “To skip,” and “To rewind” on page 24.

3 Press the **ERASE** button.
“FILE ERASE?” flashes on the display for 8 seconds.

4 Press the **ERASE** button again.
When “ERASE DONE” appears after “FILE ERASE!”, erasing is completed.

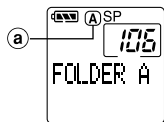

a Current folder

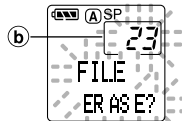
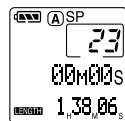

b File to be erased



File numbers are incremented automatically.

Notes

- An erased file cannot be restored.
- Locked files cannot be erased (→ P.31).
- Files stored on a SmartMedia card with a write-protect seal attached to it cannot be erased (→ P.7).

Erase All Files from a Folder

All files in a folder can be erased simultaneously, except for locked files (→ P.31).

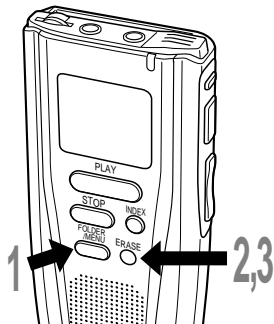

1 Press the **FOLDER/MENU** button to choose the folder in which you want to erase all files.

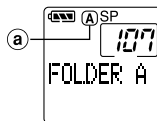

a Folder from which to erase files

2 Press the **ERASE** button for **3 seconds or longer**.
"ALL ERASE?" flashes on the display for 8 seconds.



3 Press the **ERASE** button again.
When "ERASE DONE" appears after "ALL ERASE!", erasing is completed.



Locked files are reassigned file numbers in ascending order.

.....

Notes

- It might take more than ten seconds to complete erasing tracks. Do not eject the SmartMedia card before erasing is finished.
- Files stored on a SmartMedia card with a write-protect seal attached to it cannot be erased (→ P.7).

To Partially Erase a File

You can erase a selected part of a file.

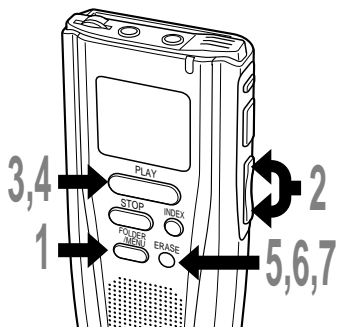

1 Press the FOLDER/MENU button to choose a folder.



2 Press the FF/+ or REW/- button several times to choose the file into which you want to erase a part. See "To fast-forward," "To skip," and "To rewind" on page 24.

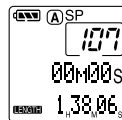

3 Press the PLAY button to play the file.

4 Press the PLAY button once again where you want to start erasing. The recorder pauses.

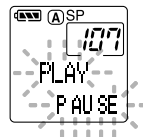

5 Press the ERASE button. The recorder starts playback automatically, and the display shows the total recording time of the file being played and "ERASE" alternately.

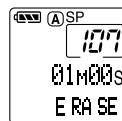
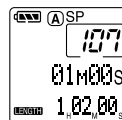

6 Press the ERASE button once again where you want to stop erasing.

The erase starting point (time) set in step 3 and the ending point (time) set in this step appear on the display for 8 seconds alternately.

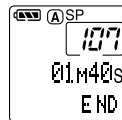

7 Press the ERASE button once again.

When "ERASE DONE" appears after "PARTIAL ERASE!", partial erasing is completed.

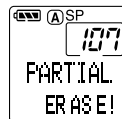

Notes

- When the recorder finishes playback of the current track before you press the ERASE button, the erase starting point (time) and ending point (time) alternate on the display for 8 seconds, similar to Step 6.
- Locked files cannot be erased (→ P.31).
- A SmartMedia card with a write-protect seal attached to it cannot be erased (→ P.7).

Using the Variable Control Voice Actuator (VCVA)

When the microphone senses that sounds have reached a preset volume, the built-in Variable Control Voice Actuator (VCVA) starts recording automatically, and stops when the volume drops. Particularly helpful for extended recording, the VCVA not only conserves memory by turning off recording during silent periods, but also makes playback more efficient and convenient.

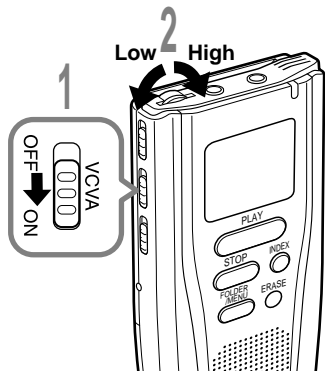

1 Start recording with the VCVA switch set to ON.

When the volume falls to a preset level or lower, recording automatically pauses, and “STANDBY VCVA” flashes on the display.

The record/play lamp glows when recording starts and flashes when recording pauses.

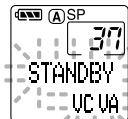

2 Using the VOLUME control, adjust the start/stop actuation level.

The higher the VOLUME control is set, the more sensitive the start/stop level becomes, allowing recording to automatically begin at a quieter level.

Notes

- The start/stop actuation level also varies depending on the selected microphone sensitivity mode (→ P.21).
- To ensure successful recordings, prior testing and adjustment of the start/stop actuation level is recommended.

Locking Files

Locking a file keeps important data from being accidentally erased.

Locked files are not erased when you choose to erase all files from a folder (→ P.27).

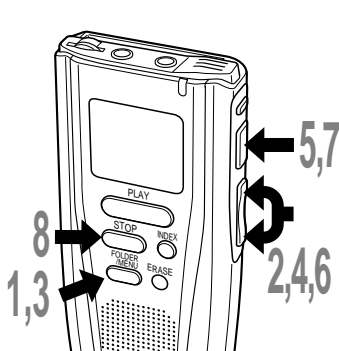

- 1 Press the FOLDER/MENU button to choose a folder.**
- 2 Press the FF/+ or REW/- button several times to choose the file you want to lock.**
- 3 Press the FOLDER/MENU button for 1 second or longer.**
The menu opens (→ P.50).
- 4 Press the FF/+ or REW/- button to open the locking screen.**

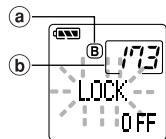

- a** Current folder
- b** File to be locked

- 5 Press the REC/SET button.**
The file locking setup process begins.
- 6 Press the FF/+ or REW/- button to choose between ON and OFF.**
ON : Locks the file and prevents it from being erased.
OFF : Unlocks the file and allows it to be erased.

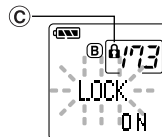

- c** Lock mark

- 7 Press the REC/SET button to complete the setup process.**
If you select ON, the lock mark appears on the display.

- 8 Press the STOP button to close the menu.**

Notes

- You cannot append, overwrite, or insert recordings into locked files.
- You cannot set index marks in locked files (→ P.32).
- Files stored on a SmartMedia card with a write-protect seal attached to it cannot be locked (→ P.7).
- Locked files are erased when a SmartMedia card is formatted (→ P.46).

Index Marks

Index marks can be incorporated into a file during recording or playback to make it easy to locate interesting information. Index marks enable faster access to important information by pressing the FF/+ or REW/- button (→ P.24, 25).

Setting an Index Mark

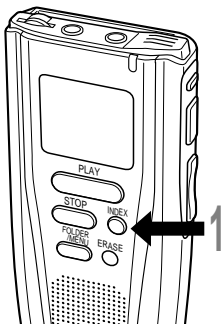

- 1 Press the **INDEX** button during recording or playback to set an index mark.

An index mark is set and the index number appears on the display.

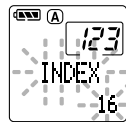

Clearing an Index Mark

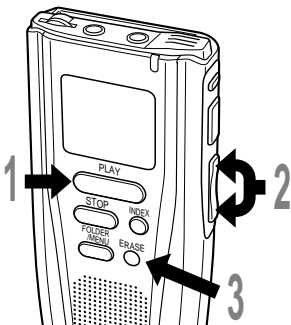

- 1 Play the file with the index mark you want to clear (→ P.23).
- 2 Press the **FF/+** or **REW/-** button to choose the index mark to be cleared.
See “Playback Functions” on pages 23 and 24.
- 3 Press the **ERASE** button while the index number appears for about 2 seconds on the display.
The index mark is erased.

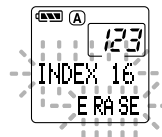

Index numbers are reassigned automatically.

.....

Notes

- Up to 16 index marks can be set in a file. Attempting to set more index marks will cause “INDEX FULL” to appear on the display.
- Index marks cannot be set or cleared in a file stored on a SmartMedia card with a write-protect seal attached to it (→ P.7).
- Index marks cannot be set or cleared in a locked file (→ P.31).

System Sounds

The recorder beeps to alert you to button operations or warn you of errors. System sounds may be turned off.

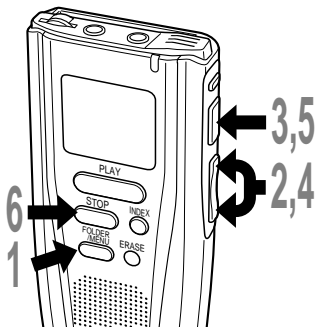

- 1 Press the FOLDER/MENU button for 1 second or longer.**

The menu opens (→ P.50).

- 2 Press the FF/+ or REW/- button to open the system sound setup screen (BEEP).**



- 3 Press the REC/SET button.**
The system sound setup process begins.

- 4 Press the FF/+ or REW/- button to choose between ON and OFF.**

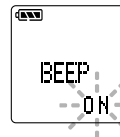

- 5 Press the REC/SET button to complete the setup process.**

- 6 Press the STOP button to close the menu.**

Note

If the alarm playback function has been set, the alarm will sound at the scheduled time even if system sounds are turned off.

Alarm Playback Function

The alarm playback function can be set to play a selected file by pressing any button when the alarm tone sounds.

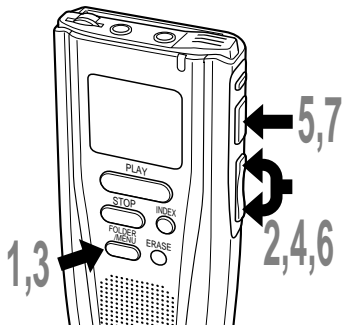

- 1 Press the FOLDER/MENU button to choose a folder.**
- 2 Press the FF/+ or REW/- button to choose the file to be played when the alarm sounds.**
- 3 Press the FOLDER/MENU button for 1 second or longer.**
The menu opens (→ P.50).
- 4 Press the FF/+ or REW/- button to open the alarm playback setup screen.**

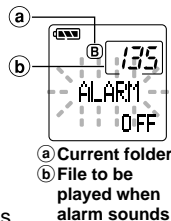

- 5 Press the REC/SET button.**
The alarm playback setup process begins.
- 6 Press the FF/+ or REW/- button to choose between ON and OFF.**
ON: Enables alarm playback.
OFF: Disables alarm playback.



- 7 Press the REC/SET button to complete the setup process.**
When you choose ON, the alarm mark lights and the scheduled time setup process begins. The time indicator will flash. → Step 8

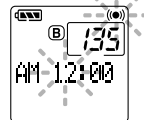

When you choose OFF, the alarm playback setup process ends, and the alarm mark disappears. → Step 12

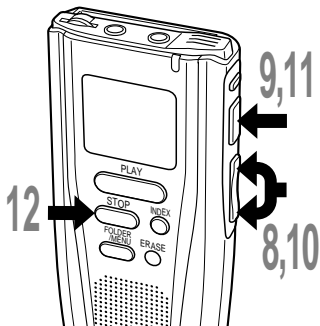

8 Press the FF/+ or REW/- button to set the hour.

9 Press the REC/SET button to accept the hour.

The minute indicator flashes.



10 Press the FF/+ or REW/- button to set the minute.

11 Press the REC/SET button to accept the minute.

12 Press the STOP button to close the menu.

An alarm tone will sound at the scheduled time. Press any button while the alarm sounds to play the file you associated with the alarm.

.....

Notes

- The alarm playback function can be set for only one file at a time.
- The alarm will sound at the scheduled time every day unless the alarm playback setting is cleared.
- The alarm will sound for 5 minutes and then stop.
- If you are using the recorder at the scheduled time, the alarm will sound after you're done.
- The alarm will sound at the scheduled time even if you are holding the recorder. The recorder begins to play the file associated with the alarm when you press any button.
- The alarm playback setting is cleared if the selected file is erased or the SmartMedia card is ejected.
- The alarm won't launch at the scheduled time if the POWER/LOCK switch is set to OFF.

Moving Files Across Folders

A recorded file can be transferred from one folder to another.

The file is added at the end of existing files in the destination folder.

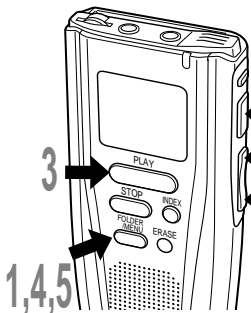
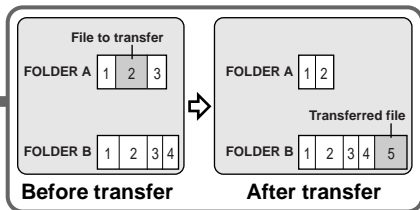

- 1 Press the FOLDER/MENU button to choose a folder.
- 2 Press the FF/+ or REW/- button several time to choose the file you want to move.
- 3 Press the PLAY button to play the file.
- 4 Press the FOLDER/MENU button while playing the file.
"INSERT REC?" appears on the display.
- 5 Press the FOLDER/MENU button once again to select "FILE MOVE?."
- 6 Press the REC/SET button.
The destination folders blink on the display.

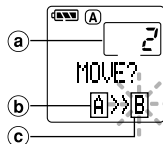
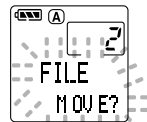

- a File to transfer
- b Current folder
- c Destination folder

7 Press the FF/+ or REW/- button to choose a destination folder.

8 Press the REC/SET button to accept the chosen destination folder.
The file is moved.

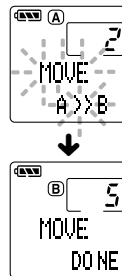

.....

Notes

- If the destination folder is full (a maximum of 199 files), "FOLDER FULL" appears on the display and files cannot be transferred to it.
- The file transfer process is aborted if you press the STOP button or leave the recorder idle for 8 seconds after you choose a destination folder.
- Files cannot be transferred from one folder to another on a SmartMedia card with a write-protect seal attached to it.

Assigning Folder Names

The three folders can each be assigned a name of up to eight characters.

The recorder comes with the following preset folder names:

Folder A : FOLDER A Folder B : FOLDER B

Folder C : FOLDER C

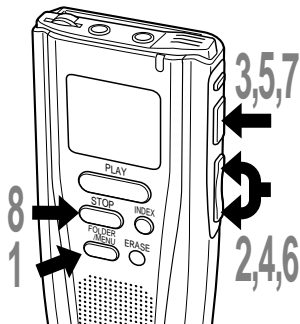

- 1 Press the FOLDER/MENU button for 1 second or longer.**

The menu opens (→ P.50).

- 2 Press the FF/+ or REW/- button to open the folder name setup screen.**



- 3 Press the REC/SET button.**

The folder name setup process begins.

- 4 Press the FF/+ or REW/- button to choose the folder you want to name.**

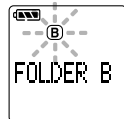

- 5 Press the REC/SET button to accept the chosen folder.**

The first character of the chosen folder's name flashes.

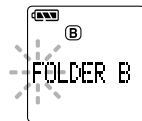

Example

FOLDER A : MEMO

FOLDER B : MEETING

FOLDER C : TO DO

6 Press the FF/+ or REW/- button to choose characters.

Available characters are 0 to 9, A to Z, and space.

REC button: To input the selected character and advance the input position.

NEW button: Acts as a backspace.

ERASE button: To delete the flashing character.

INDEX button: Lets you insert one space.

7 When you have finished setting the folder name, press the REC/SET button for 1 second or longer.

This completes the folder naming procedure. (If you wish to enter another folder name, press the FF/+ or REW/- button to open the folder name setup screen and repeat the process starting from Step 3.)

8 Press the STOP button to close the menu.

.....

Notes

- The folder naming process ends automatically when the eighth character is set.
- Folder names can be changed only if a SmartMedia card is inserted.
- A SmartMedia card with a write-protect seal attached to it cannot be changed.
- When a SmartMedia card is formatted, folder names that you assigned will be reset to the initial names.

Setting Priority Levels

You can set a priority level for each file.

You can choose between “HIGH” and “NORMAL.” The default is NORMAL.

To Set a Priority Level for an Existing File

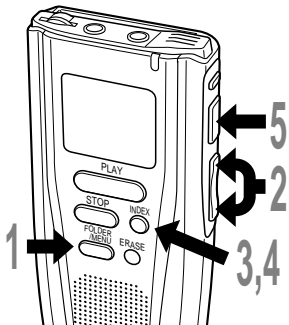

1 Press the FOLDER/MENU button to choose a folder.

2 Press the FF/+ or REW/- button several times to choose the file to set a priority level.

3 Press the INDEX button for longer than 1 second.

“PRIORITY NORMAL” is displayed.

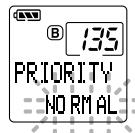

4 Press the INDEX button to choose between “HIGH” and “NORMAL.”



5 Press the REC/SET button to accept the choice.

Notes

- A locked file cannot be assigned a priority level.
- A SmartMedia card with a write-protect seal attached to it cannot be set.

To Set a Priority for a New File

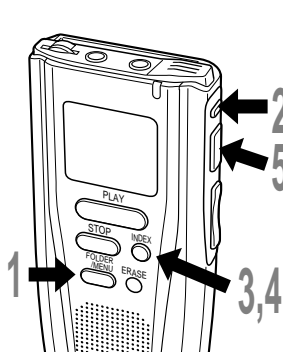

1 Press the FOLDER/MENU button to choose a folder.

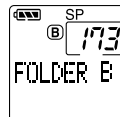

2 Press the NEW button.
A new file is created.

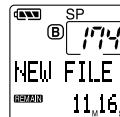

3 Press the INDEX button for longer than 1 second.
"PRIORITY NORMAL" is displayed.

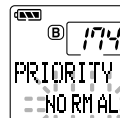

4 Press the INDEX button to choose between "HIGH" and "NORMAL."



5 Press the REC/SET button to accept the choice.

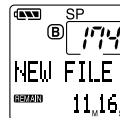

The recorder displays the new file once the priority is set.

Note

You may not be able to change the priority level for files recorded on another DS-3000.

Setting Job Data

You may record the name of the person who made the recording (Author ID) and code name for classification (Work Type) for each file automatically when recording is done.

Using the supplied DSS Player, importing a Job Data list (a list of these Author IDs and Work Types made on a PC) to the recorder saves you the bother of entering the IDs or Types.

These Author IDs and Work Types are set as "AAAA" at the factory.

Setting an Author ID

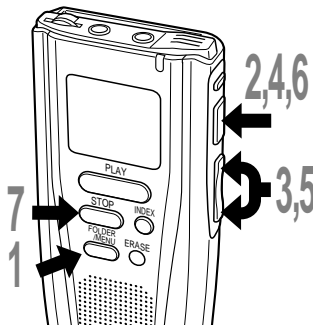

1 Press and hold the FOLDER/MENU button for more than 1 second to open the menu (→ P. 50).

"AUTHOR ID" appears on the display.

2 Press the REC/SET button.

The Author ID currently assigned to the recorder appears on the display.

3 Press the FF/+ or REW/- button to select the Author ID that you want to assign to the recorder from the ID list*.

If you select an ID from the list, go to step 6.

* If no ID list is imported from a PC, the current MANUAL AUTHOR ID appears on the display. In such a case, proceed to step 4.

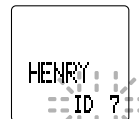

ID List

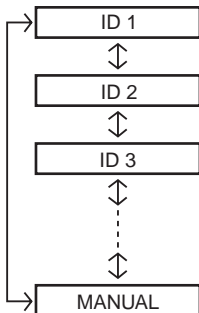

- 4 Press the REC/SET button.**
The current MANUAL AUTHOR ID appears on the display with the first character flashing.



- 5 Press the FF/+ or REW/- button to choose characters.**

Available characters are 0 to 9, A to Z, and space.

REC button: To input the selected character and advance the input position.

NEW button: Acts as a backspace.

ERASE button: To delete the flashing character.

INDEX button: Lets you insert one space.

- 6 After selecting or entering the Author ID, press and hold the REC/SET button for more than 1 second to make it the current Author ID.**

* If you selected an Author ID from the list in step 3, press the REC/SET button.

- 7 Press the STOP button to close the menu.**
-

Notes

- An Author name must be of more than 3 and fewer than 17 characters.
- You must not use a space within the first four characters of a filename.
- You cannot change the Author ID of a file which you have already recorded.

Setting a Work Type

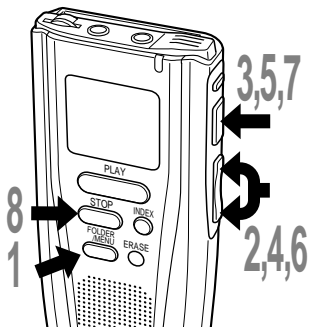

1 Press and hold the **FOLDER/MENU** button for more than 1 second to open the menu (→ P. 50).

2 Press the **FF/+** or **REW/-** button until “**WORK TYPE**” appears on the display.



3 Press the **REC/SET** button.
The Work Type currently assigned to the recorder appears on the display.

4 Press the **FF/+** or **REW/-** button to select the Work Type that you want to assign to the recorder from the **TYPE list***.

If you select a TYPE from the list, go to step 7.

* If no TYPE list is imported from a PC, the current **MANUAL WORK TYPE** appears on the display. In such a case, proceed to step 5.



5 Press the **REC/SET** button.
The current **MANUAL WORK TYPE** appears on the display with the first character flashing.



Type List

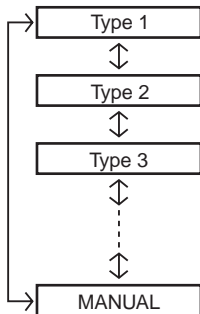

6 Press the FF/+ or REW/- button to choose characters.

Available characters are 0 to 9, A to Z, and space.

REC button: To input the selected character and advance the input position.

NEW button: Acts as a backspace.

ERASE button: To delete the flashing character.

INDEX button: Lets you insert one space.

7 After selecting or entering the Work Type, press and hold the REC/SET button for more than 1 second* to make it the current Work Type.

* If you selected a Work Type from the list in step 4, press the REC/SET button.

8 Press the STOP button to close the menu.

.....

Notes

- The Work Type must be of fewer than 17 characters. You can use a space anywhere in a filename.
- You cannot change the Work Type of a file which you have already recorded.

Formatting SmartMedia

Formatting prepares SmartMedia cards for recording. SmartMedia cards that have been used on non-Olympus devices, or that can't be accessed by this unit, require formatting. The SmartMedia card that comes with this unit and Olympus SmartMedia cards are preformatted and can be used immediately following purchase.

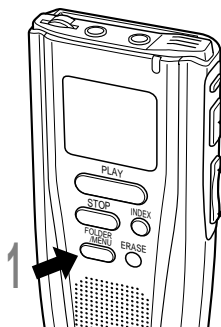

- 1 Press the FOLDER/MENU button for 1 second or longer.**

The menu opens (→ P.50).

- 2 Press the FF/+ or REW/- button to open the FORMAT screen.**

- 3 Press the REC/SET button.**
The formatting process is selected.

- 4 Press the FF/+ or REW/- button to choose “YES?”.**

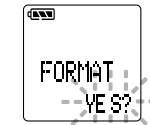

- 5 Press the REC/SET button again.**
Formatting begins and an indicator flashes on the display.

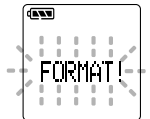

“FORMAT DONE” displays when formatting ends.

Transferring Data to a PC

Notes

- When a SmartMedia card is formatted, all the stored data, including locked files, is erased.
- A SmartMedia card with a write-protect seal attached to it cannot be formatted (→ P.7).
- After formatting a SmartMedia card, the display will show "NEW FILE".*

*New files that you create after formatting the SmartMedia will be stored in the A folder.



Never use any SmartMedia card other than one that has been formatted with this unit or with a CAMEDIA series Olympus digital camera.

Other SmartMedia cards may not perform as expected.

This recorder is equipped with a USB terminal to enable recorded voice data to be transferred to a PC. For more details on how to transfer data and voice recognition software, refer to the supplied DSS Player Pro manual.

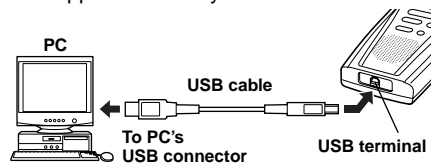

Stop the recorder before plugging in the USB cable.

PC platform

Operating system:

Microsoft Windows 95/98(SE)/

NT/2000 Professional

IBM PC/AT compatible

PC:

CPU:

Intel Pentium 166MHz or

faster; AMD-K6 or faster

32MB or more

RAM:

Hard drive space:

25MB or more (Plus space for sound data files.)

Sound card:

Creative Labs Sound Blaster 16 or 100 % compatible sound card

Display:

800 x 600 pixels or more, 256 colors or more

CD-ROM drive:

2 x or faster

USB port

Audio I/O terminals:

Microphone input and earphone (or speaker) output

Tip

When the SmartMedia card is ejected, data can be transferred from the SmartMedia card to a PC via a number of ways. See Page 54 for optional accessories to download SmartMedia through your PCMCIA, USB, or Floppy Disk drives.

Dealer Option Items

Some additional options can be set by your Professional Olympus dictation dealer. For details on the functions and operation of this optional accessory, consult the dealer from whom you purchased the recorder.

Hold

All operation buttons are disabled. This feature is useful when the recorder has to be carried in a bag or pocket.

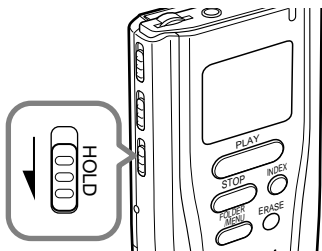

Setting the HOLD switch to the HOLD position.

When the recorder is in hold mode, the time shows on the display.

Remember to reset the HOLD switch when using the recorder. Setting the HOLD switch to the HOLD position locks the recorder. All buttons are disabled.

Reset

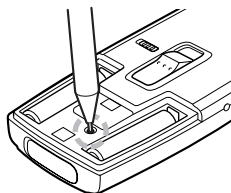

If the display or the recorder acts strangely, lightly press the reset button in the battery compartment with the tip of a ballpoint pen or a similar object.

Notes

- Do not use a sharp object such as a needle.
- The time/date setup process launches automatically when you press the reset button. Set the time and date again (→ P.12, 13).
- Audio data is not erased when the recorder is reset.

Training your PC for Voice Recognition

When you use voice-recognition software such as IBM ViaVoice, it is recommended that you set the recorder to PC microphone and have the software learn the characteristics of the speaker's voice and the recorder's built-in microphone to maximize the accuracy of voice recognition.

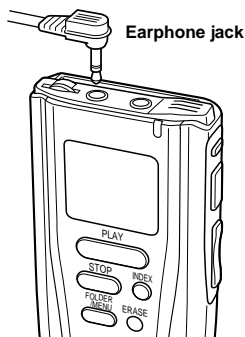

1 Connect the KP-4 PC connection cable (supplied) to the recorder's earphone jack and the PC microphone jack of your PC.

2 Start the software on your PC and prepare it to receive voice input. (Refer to the User's manual of the software for details.)

3 Press and hold the NEW button to get into PC train mode.

The Record/Play indicator lamp lights in red, and "TRAIN PC" flashes on the display, while you are holding the NEW button pressed.



4 Speak into the recorder's microphone.

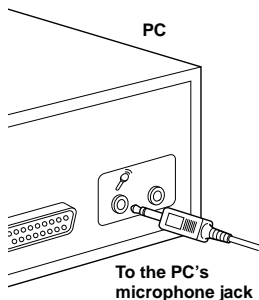

Notes

- When the recorder is connected to a PC with USB connection, you cannot perform these procedures.
- While the recorder is set as PC microphone, the output level of the earphone jack is fixed.
- Refer to the user's manuals of DSS Player Pro and your voice recognition software for details.

Menu List

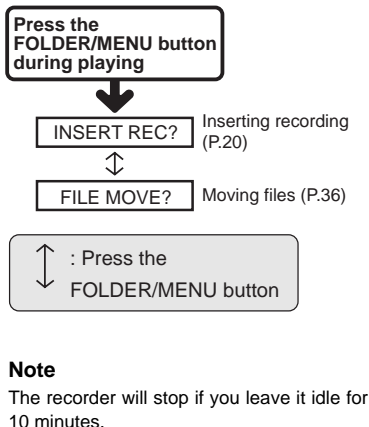
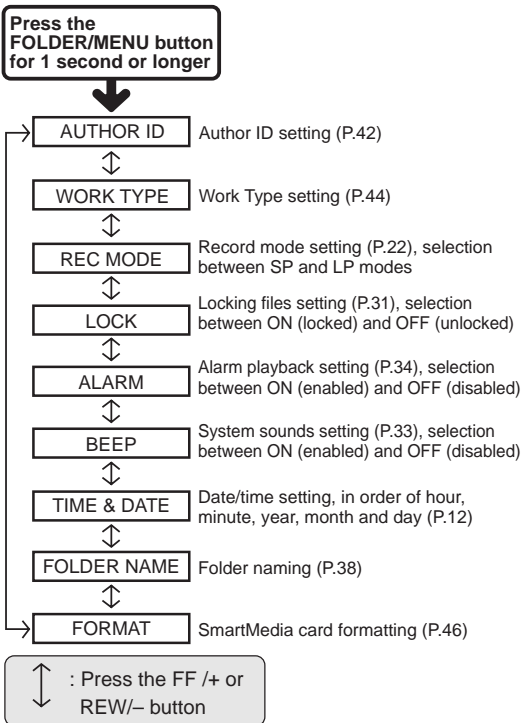

Notes

- If you press the STOP button, the REC/SET button, or the FOLDER/MENU button during a menu setup operation, the recorder will stop and apply the items that were set to that point.
- The recorder will stop if you leave it idle for 3 minutes during a menu setup operation, when a selected item is not applied.

Alarm Message List

Message	Meaning	Explanation	Action
BATTERY LOW	Low battery power	Battery power is getting low.	Replace with new batteries (→ P.11).
🔒 CARD LOCK	Write-protected	Tried to record to, or erase from, a SmartMedia card with a write-protect seal attached.	Remove the write-protect seal from the SmartMedia card and try again (→ P.14).
CARD ERROR	Incompatible SmartMedia	An incompatible SmartMedia card was inserted.	Insert a compatible SmartMedia card (→ P.6).
EJECT ERROR	SmartMedia ejection error	The SmartMedia card was ejected during an operation.	Reinsert the SmartMedia card.
FOLDER FULL	Folder full	The folder is full of files (maximum of 199 files).	Erase files that are no longer required, or insert another SmartMedia card (→ P.26).
FORMAT ERROR	Formatting error	An error was encountered while formatting.	Reinsert the SmartMedia card and then reformat it (→ P.46).
INDEX FULL	Index full	The file is full of index marks (maximum of 16 marks).	Erase index marks that are no longer required (→ P.32).
INSERT CARD	No card	There is no SmartMedia card inserted.	Insert a SmartMedia card (→ P.14).
🔒 LOCK ON	Erase-locked	Attempted to overwrite, insert additional recording to, or erase a locked file.	Unlock the file (→ P.31).
MEMORY FULL	Zero remaining memory	The SmartMedia card has no remaining memory.	Erase files that are no longer required or insert another SmartMedia card (→ P.6, 26).
NO FILE	No file	No files were found in the folder.	Select another folder.
PRIORITY ERROR	Priority cannot be set for the file.	You tried to set a priority level for a file recorded on another recorder.	In such a case, you cannot set a priority for the file.
🔒 READONLY	Unrecordable	There is something wrong with the SmartMedia card.	Back up the data (→ P.47) and format the SmartMedia card.
SAME FILE	File cannot be transferred	A file with the same file name* already exists in the destination folder.	Transfer the file to another folder.
TRAIN PC	PC microphone indicator	The recorder is being used as a PC microphone (→ P.49).	Refer to the supplied DSS Player Pro manual.

* File names are assigned during recording for file management purposes.

Troubleshooting

Symptom	Probable cause	Action
Nothing appears on the display.	The batteries are not loaded properly.	Verify polarity is correct.
	The batteries are dead.	Replace with new batteries.
	The POWER/LOCK switch is set to OFF.	Set the POWER/LOCK switch to ON.
Won't start	If none of these suggestions works	Reset the recorder (→ P.48).
	The recorder is in HOLD mode.	Release the recorder from HOLD (→ P.48).
	The SmartMedia card is not formatted.	Format the SmartMedia card (→ P.46).
Unable to record	The batteries are dead.	Replace with new batteries.
	The SmartMedia card has a write-protect seal attached to it.	Remove the seal (→ P.7).
	The SmartMedia card is unformatted.	Format the SmartMedia card (→ P.46).
No playback tone heard	The SmartMedia card does not have enough memory.	Erase unnecessary files or insert another SmartMedia card.
	The maximum number of files has been reached.	Check another folder.
	The earphone is connected.	Disconnect the earphone jack.
Unable to erase	The VOLUME control is set to 0.	Adjust the VOLUME control.
	The file is locked.	Unlock the file (→ P.31).
Noise heard during playback	The SmartMedia card has a write-protect seal attached to it.	Remove the seal (→ P.7).
	The recorder was shaken during recording.	—
	The recorder was placed near a cell phone or fluorescent lamp while recording or during playback.	Move the recorder.
Recording level too low	The microphone sensitivity is too low.	Set the microphone sensitivity to CONF mode and try again (→ P.21).
Unable to set index marks	The maximum number of index marks (16) has been reached.	Erase unnecessary index marks (→ P.32).
	The SmartMedia card has a write-protect seal attached to it.	Remove the seal (→ P.7).
	The file is locked.	Unlock the file (→ P.31).
Won't work with AC adapter	A non-standard AC adapter is being used.	Use the Olympus A321 (for US, Canada) or A322 (for Europe except U.K) AC adapter (Optional).
Unable to eject the SmartMedia card	The POWER/LOCK switch is set to ON.	Set the POWER/LOCK switch to OFF.

Specifications

Recording format DSS (Digital Speech Standard)

Recording media 3 V (3.3 V) SmartMedia cards
(4 to 64MB)

Card format SSFDC Forum-compliant
SmartMedia format

Input level -70 dBv

Sampling frequency
SP mode: 12 kHz
LP mode: 8 kHz

Overall frequency response
SP mode: 300 to 5,000 Hz
LP mode: 300 to 3,000 Hz

Recording time SP mode: 2 hours 35 minutes
(16MB card)
LP mode: 5 hours 30 minutes
(16MB card)

Speaker Built-in \varnothing 28 mm round dynamic
speaker

Microphone jack \varnothing 3.5 mm mini-jack, impedance
2 k Ω

Earphone jack \varnothing 3.5 mm mini-jack, impedance
8 Ω

Maximum working output (3 V DC)
100 mW or more (8 Ω speaker)

Input power requirement
Rated voltage: 3 V
Batteries: Two AAA
batteries
(LR03 or R03)
External power supply:
AC adapter

Battery life (Recording or Playing):
Approx. 11 hours (with alkaline
batteries, based on our standard
testing procedure)

External dimensions
109.5 x 50.0 x 16.7 mm (without
protrusions)

Weight 86 g (including batteries)

* Specifications and design are subject to
change without notice.

* Battery life varies greatly according to type
of batteries used and the conditions of use.

Accessories (optional)

SmartMedia cards of 4, 8, 16, 32, and 64MB:M-4/8/16/32/64

Olympus CAMEDIA digital camera series 3 V (3.3 V) SmartMedia memory cards can be used.

PC card adapter:MA-2E

Allows files to be transferred to a PC that has a PC card slot or PC card drive.

FlashPath (floppy disk adapter):MAFP-2E

Allows files to be transferred to a PC with a 3.5" floppy disk drive.

USB SmartMedia reader/writer:MAUSB-1 (US and Canada) or MAUSB-2 (Europe)

Allows data to be transferred to and from a PC running Windows98/Windows2000 professional quickly and effortlessly.

Conference microphone:ME7

A highly sensitive directional microphone (shotgun microphone). Used to record speakers at a distance.

External microphone:ME10*

A lavalier omnidirectional microphone that clips to clothing. Used to record your own voice or people near you.

Noise-Cancellation microphone:ME12

Used to get crisp recordings of your own voice by reducing the effects of ambient noise. Recommended to improve the accuracy when using voice-recognition software.

AC adapter:A321 (US and Canada) or A322 (Europe except U.K.)

Connecting cord:KA232*

Use to connect the microphone jack of this unit to a radio or other sound source.

Plug adapter:PA3

An adapter that connects devices such as microphones with $\varnothing 2.5$ mm mini-plugs to the unit's $\varnothing 3.5$ mm mini-jack.

PC Transcription kit: AS-3000

The AS-3000 transcription kit (sold separately) provides you with a PC-footswitch and DSS Player Pro Transcription Module for easy transcription of DSS recordings.

* Use these accessories with the PA3 plug adapter.

Technical Assistance And Support

The following are for only technical questions and support about OLYMPUS DSS player.

- ◆ Technical Hotline Number in the U.S. and Canada
1-888-553-4448
- ◆ User Support E-mail address in the U.S. and Canada
distec@olympus.com
- ◆ Technical Hotline Number in Europe
Toll free number
008000 67 10 83 00
available for Austria, Belgium, Denmark, France, Germany, Netherlands, Norway, Sweden,
Switzerland, United Kingdom

Charged numbers
+49 180 567 1083
available for Finland, Italy, Luxemburg, Portugal, Spain and Czech Republic
+49 40 23773 899
available for Greece, Croatia, Hungary and the rest of Europe
- ◆ User Support E-mail address in Europe
dss.support@olympus-europa.com

The following are for only technical questions and support about IBM ViaVoice.

- ◆ [http://www.ibm.com/software/speech/ support/faqolympus.html](http://www.ibm.com/software/speech/support/faqolympus.html)

Declaration of Conformity

Model Number: DS-3000
Trade Name: DIGITAL VOICE RECORDER
Responsible Party: OLYMPUS AMERICA INC.
Address: 2 Corporate Center Drive, Melville, NY 11747-3157, U.S.A.
Telephone Number: 800-622-6372

This device Complies with Part 15 of the FCC Rules. Operation is subject to the following two conditions: (1) This device may not cause harmful interference, and (2) this device must accept any interference received, including interference that may cause undesired operation.

Trade Name: DIGITAL VOICE RECORDER
Model Number: DS-3000



Tested To Comply
With FCC Standards

FOR HOME OR OFFICE USE

Canadian RFI

This digital apparatus does not exceed the Class B limits for radio noise emissions from digital apparatus as set out in the Radio Interference Regulations of the Canadian Department of Communications.

Cet appareil numerique ne depasse pas limites de Categorie B pour les emissions de bruit radio emanant d'appareils numeriques, tel que prevu dans les Reglements sur l'Interference Radio du Department Canadian des Communications.

OLYMPUS®

OLYMPUS OPTICAL CO., LTD.

San-Ei Building, 22-2, Nishi Shinjuku 1-chome, Shinjuku-ku, Tokyo, Japan. Tel. 03-3340-2211

OLYMPUS AMERICA INC.

Two Corporate Center Drive, Melville, NY 11747-3157, U.S.A. Tel. 1-800-622-6372

OLYMPUS OPTICAL CO (EUROPA) GMBH.

(Premises/Goods delivery) Wendenstrasse 14-18, 20097 Hamburg, Germany. Tel. 040-237730

(Letters) Postfach 10 49 08. 20034 Hamburg. Germany.

OLYMPUS OPTICAL CO. (U.K.) LTD.

2-8 Honduras Street, London EC1Y 0TX, United Kingdom, Tel. 020-7253-2772

<http://www.olympus.com>



“CE” mark indicates that this product complies with the European requirements for safety, health, environment and customer protection.



L'indication “CE” signifie que ce produit est conforme aux exigences concernant la sécurité, la santé, l'environnement et la protection du consommateur.



Das “CE” Zeichen bestätigt die Übereinstimmung mit den Europäischen Bestimmungen für Betriebssicherheit und Umweltschutz.



Il marchio “CE” indica che questo prodotto è conforme alle norme della comunità europea per quanto riguarda la sicurezza, la salute, l'ambiente e la protezione del consumatore.



La marca “CE” indica que este producto se encuentra de conformidad con las exigencias europeas sobre seguridad, salud, medio ambiente y protección al consumidor.