

Memorex®

Is it live or is it Memorex?™

**MC7100
Suffix A**

User's Guide

*CD Clock Radio with
Dual Alarm and
Detachable Speaker*

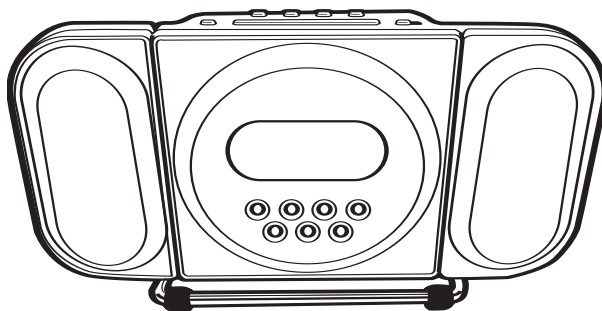

**Before operating this product,
please read these instructions completely.**

SAFETY PRECAUTIONS



CAUTION
RISK OF ELECTRIC SHOCK
DO NOT OPEN



CAUTION: TO REDUCE THE RISK OF ELECTRIC SHOCK, DO NOT REMOVE COVER (OR BACK). NO USER-SERVICEABLE PARTS INSIDE. REFER SERVICING TO QUALIFIED SERVICE PERSONNEL.



The lightning flash with arrowhead symbol within an equilateral triangle is intended to alert the user to the presence of uninsulated 'dangerous voltage' within the product's enclosure that may be of sufficient magnitude to constitute a risk of electric shock to persons.



The exclamation point within an equilateral triangle is intended to alert the user to the presence of important operating and maintenance (servicing) instructions in the literature accompanying the appliance.



Invisible and hazardous laser radiation when open and interlock failed or defeated. Avoid direct exposure to beam.

FCC WARNING:

This equipment may generate or use radio frequency energy. Changes or modifications to this equipment may cause harmful interference unless the modifications are expressly approved in the instruction manual. The user could lose the authority to operate this equipment if an unauthorized change or modification is made.

LASER SAFETY: This unit employs a laser. Only qualified service personnel should attempt to service this device due to possible eye injury.

CAUTION: USE OF CONTROLS, ADJUSTMENTS OR PERFORMANCE PROCEDURE HEREIN MAY RESULT IN HAZARDOUS RADIATION EXPOSURE.

PLEASE KEEP ALL PACKAGING MATERIAL FOR AT LEAST 90 DAYS IN CASE YOU NEED TO RETURN THIS PRODUCT TO YOUR PLACE OF PURCHASE OR MEMOREX.

INFORMATION:

This equipment has been tested and found to comply with the limits for a Class B digital device, pursuant to Part 15 of the FCC Rules. These limits are designed to provide reasonable protection against harmful interference in a residential installation. This equipment generates, uses and can radiate radio frequency energy and, if not installed and used in accordance with instructions, may cause harmful interference to radio communications. However, there is no guarantee that interference will not occur in a particular installation. If this equipment does cause harmful interference to radio or television reception, which can be determined by turning the equipment off and on, the user is encouraged to try to correct the interference by one or more of the following measures:

- Reorient or relocate the receiving antenna.
- Increase the separation between the equipment and receiver.
- Connect the equipment into an outlet on a circuit different from that to which the receiver is connected.
- Consult the dealer or an experienced radio/TV technician for help.

IMPORTANT SAFETY INSTRUCTIONS

Before using the unit, be sure to read all operating instructions carefully. Please note that these are general precautions and may not pertain to your unit. For example, this unit may not have the capability to be connected to an outdoor antenna.

1. READ INSTRUCTIONS

All the safety and operating instructions should be read before the product is operated.

2. RETAIN INSTRUCTIONS

The safety and operating instructions should be retained for future reference.

3. HEED WARNINGS

All warnings on the product and in the operating instructions should be adhered to.

4. FOLLOW INSTRUCTIONS

All operating and use instructions should be followed.

5. CLEANING

Unplug this product from the wall outlet before cleaning. Do not use liquid cleaners or aerosol cleaners. Use a dry cloth for cleaning.

6. ATTACHMENTS

Do not use attachments not recommended by the product's manufacturer as they may cause hazards.

7. WATER AND MOISTURE

Do not use this product near water—for example: near a bathtub, washbowl, kitchen sink or laundry tub; in a wet basement; or near a swimming pool.

8. ACCESSORIES

Do not place this product on an unstable cart, stand, tripod, bracket or table. The product may fall, causing serious injury and serious damage to the product. Use only with a cart, stand, tripod, bracket or table recommended by the manufacturer or sold with the product. Any mounting of the product should follow the manufacturer's instructions, and should use a mounting accessory recommended by the manufacturer.

- 8A.** An appliance and cart combination should be moved with care. Quick stops, excessive force and uneven surfaces may cause the appliance and cart combination to overturn.

9. VENTILATION

Slots and openings in the cabinet and in the back or bottom are provided for ventilation, to ensure reliable operation of the product and to protect it from overheating. These openings must not be blocked or covered. The openings should never be blocked by placing the product on a bed, sofa, rug or other similar surface. This product should never be placed near or over a radiator or heat source. This product should not be placed in a built-in installation such as a bookcase or rack unless proper ventilation is provided or the manufacturer's instructions have been adhered to.

10. POWER SOURCES

This product should be operated only from the type of power source indicated on the marking



IMPORTANT SAFETY INSTRUCTIONS (CONTINUED)

label. If you are not sure of the type of power supply to your home, consult your appliance dealer or local power company. For products intended to operate from battery power, or other sources, refer to the operating instructions.

11. GROUNDING OR POLARIZATION

This product is equipped with a polarized alternating-current line plug (a plug having one blade wider than the other). This plug will fit into the power outlet only one way. This is a safety feature. If you are unable to insert the plug fully into the outlet, try reversing the plug. If the plug should still fail to fit, contact your electrician to replace your obsolete outlet. Do not defeat the safety purpose of the polarized plug.

12. POWER-CORD PROTECTION

Power-supply cords should be routed so that they are not likely to be walked on or pinched by items placed upon or against them, paying particular attention to cords at plugs, convenience receptacles, and the point where they exit from the appliance.

13. LIGHTNING

To protect your product from a lightning storm, or when it is left unattended and unused for long periods of time, unplug it from the wall outlet and disconnect the antenna or cable system. This will prevent damage to the product due to lightning and power-line surges.

14. POWER LINES

An outside antenna system should not be located in the vicinity of overhead power lines or other electric light or power circuits, or where it can fall into such power lines or circuits. When installing an outside antenna system, extreme care should be taken to keep from touching such power lines or circuits as contact with them might be fatal.

15. OVERLOADING

Do not overload wall outlets and extension cords as this can result in a risk of fire or electric shock.

16. OBJECT AND LIQUID ENTRY

Never push objects of any kind into this product through openings as they may touch dangerous voltage points or short out parts that could result in fire or electric shock. Never spill or spray any type of liquid on the product.

17. SERVICING

Do not attempt to service this product yourself as opening or removing covers may expose you to dangerous voltage or other hazards. Refer all servicing to qualified service personnel.

18. REPLACEMENT PARTS

When replacement parts are required, be sure

the service technician uses replacement parts specified by the manufacturer or those that have the same characteristics as the original part. Unauthorized substitutions may result in fire, electric shock or other hazards.

19. SAFETY CHECK

Upon completion of any service or repairs to this product, ask the service technician to perform safety checks to determine that the product is in proper operating condition.

20. WALL OR CEILING MOUNTING

The product should be mounted to a wall or ceiling only as recommended by the manufacturer.

21. DAMAGE REQUIRING SERVICE

Unplug the product from the wall outlet and refer servicing to qualified service personnel under the following conditions:

- a. When the power-supply cord or plug is damaged.
- b. If liquid has been spilled or objects have fallen into the product.
- c. If the product has been exposed to rain or water.
- d. If the product does not operate normally by following the operating instructions. Adjust only those controls that are covered by the operating instructions, as an adjustment of other controls may result in damage and will often require extensive work by a qualified technician to restore the product to its normal operation.
- e. If the product has been dropped or the cabinet has been damaged.
- f. When the product exhibits a distinct change in performance—this indicates a need for service.

22. HEAT

The product should be situated away from heat sources such as radiators, heat registers, stoves or other products (including amplifiers) that produce heat.

23. NOTE TO CATV SYSTEM INSTALLER

This reminder is provided to call the CATV system installer's attention to Article 820-40 of the NEC that provides guidelines for proper grounding and, in particular, specifies that the cable ground shall be connected to the grounding system of the building, as close to the point of cable entry as practical.

24. NONUSE PERIODS

The power cord of the appliance should be unplugged from the outlet when left unused for a long period of time.

Dear Customer:

Selecting fine audio equipment such as the unit you've just purchased is only the start of your musical enjoyment. Now it's time to consider how you can maximize the fun and excitement your equipment offers. This manufacturer and the Electronic Industries Association's Consumer Electronics Group want you to get the most out of your equipment by playing it at a safe level. One that lets the sound come through loud and clear without annoying blaring or distortion—and, most importantly, without affecting your sensitive hearing. Sound can be deceiving. Over time your hearing "comfort level" adapts to higher volumes of sound. So what sounds "normal" can actually be loud and harmful to your hearing. Guard against this by setting your equipment at a safe level BEFORE your hearing adapts.

To establish a safe level:

- Start your volume control at a low setting.
- Slowly increase the sound until you can hear it comfortably and clearly, and without distortion.

Once you have established a comfortable sound level:

- Set the dial and leave it there.

Taking a minute to do this now will help to prevent hearing damage or loss in the future. After all, we want you listening for a lifetime.

We Want You Listening For A Lifetime

Used wisely, your new sound equipment will provide a lifetime of fun and enjoyment. Since hearing damage from loud noise is often undetectable until it is too late, this manufacturer and the Electronic Industries Association's Consumer Electronics Group recommend you avoid prolonged exposure to excessive noise. This list of sound levels is included for your protection.

Decibel

<u>Level</u>	<u>Example</u>
30	Quiet library, soft whispers
40	Living room, refrigerator, bedroom away from traffic
50	Light traffic, normal conversation, quiet office
60	Air conditioner at 20 feet, sewing machine
70	Vacuum cleaner, hair dryer, noisy restaurant
80	Average city traffic, garbage disposals, alarm clock at two feet

THE FOLLOWING NOISES CAN BE DANGEROUS UNDER CONSTANT EXPOSURE:

90	Subway, motorcycle, truck traffic, lawn mower
100	Garbage truck, chain saw, pneumatic drill
120	Rock band concert in front of speakers, thunderclap
140	Gunshot blast, jet engine
180	Rocket launching pad

Information courtesy of the Deafness Research Foundation.



LOCATION OF CONTROLS

FRONT

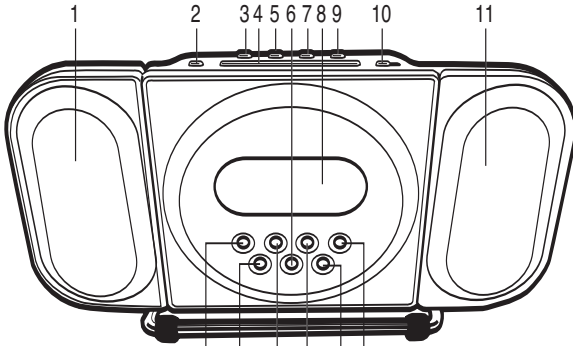

REAR

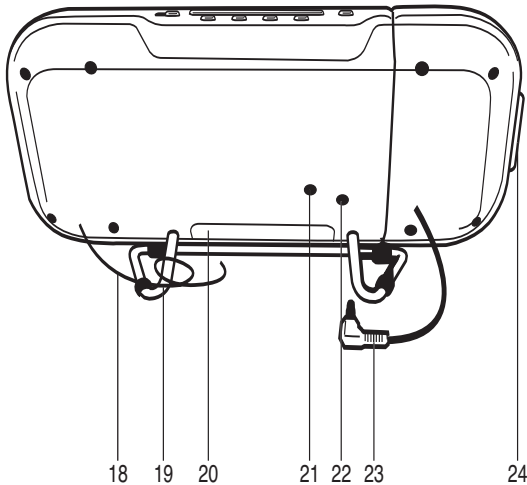

1. Left Detachable Speaker
2. POWER Button
3. RADIO/BAND Button
4. SNOOZE Button
5. ALARM 1/2 ON/OFF Button
6. REPEAT/ALARM 1/2 SET Button
7. VOLUME Down Button
8. Display
9. VOLUME Up Button
10. DOOR OPEN Switch
11. Right Speaker
12. Play/Pause (▶||)/CD Button
13. PROG./CH SAVE Button
14. STOP (■)/CLOCK SET Button
15. Tune/Skip/Search/Hr ⏪ Button
16. MODE/CH+/ALARM SELECT Button
17. Tune/Skip/Search/Min ⏩ Button
18. FM Antenna Wire
19. Stand
20. Battery Compartment
21. DC Jack
22. Left Speaker Jack
23. Left Speaker Wire
24. SNOOZE Button

INSTALLATION

AC ADAPTER CONNECTION

Connect the AC adapter (included) to an AC outlet having 120V, 60Hz AC only. Plug the small end into the DC jack on the rear of the unit.

CAUTION: Do not touch the AC adapter with wet hands. Fully insert the plug without exposing any part of the blade.

DC 6V 

INSERTING BATTERIES

Two AAA size batteries can also be used to power and/or to provide a backup for the clock and alarm time for this unit as follows:

1. Open the battery door by sliding it towards the bottom of the unit.
2. Insert two (2) "AAA" batteries as shown. Alkaline batteries are recommended for the longest playing time.
3. Slide the battery door back on.

NOTE: The batteries are used to back-up the clock and alarm time only when the AC adapter is disconnected or if there is a power failure.

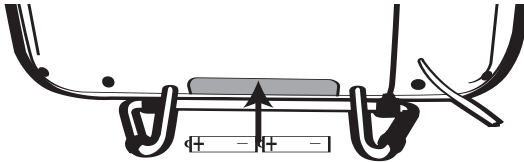

BATTERY PRECAUTIONS

Follow these precautions when using batteries in this device:

1. Use only the size and type of batteries specified.
2. Be sure to follow the correct polarity when installing the batteries as indicated in the battery compartment. Reversed batteries may cause damage to the device.
3. Do not mix different types of batteries together (e.g. Alkaline, Rechargeable and Carbon-zinc) or old batteries with fresh ones.
4. If the device is not to be used for a long period of time, remove the batteries to prevent damage or injury from possible battery leakage.
5. Do not try to recharge batteries not intended to be recharged; they can overheat and rupture. (Follow battery manufacturer's directions.)

BACKLIGHT

If the power supply is connected to the DC 6V IN jack, the backlight will always light on in the display.

INSTALLATION (CONTINUED)

SPEAKER CONNECTION

1. The right speaker cannot be removed from the unit. The left speaker can be removed from the unit, if desired. To remove the left speaker, simply push up on the speaker as shown in figure 1. To reinsert the speaker, line up the pins as shown in figure 2 and push down until a click is heard.

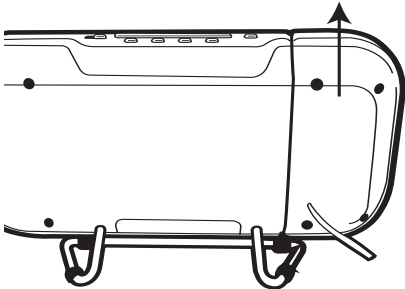

FIGURE 1

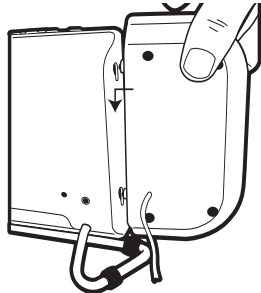

FIGURE 2

2. Connect the left speaker to the Left Speaker jack as shown in figure 3. To extend the speaker wire, connect the speaker plug into the extender (the side with the hole) and the other side of the extender (with the pin) into the speaker jack (see figure 4).

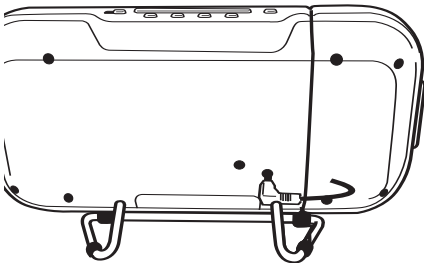

FIGURE 3

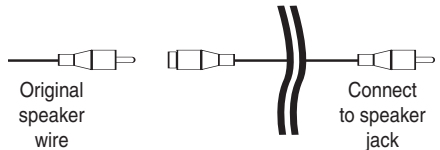
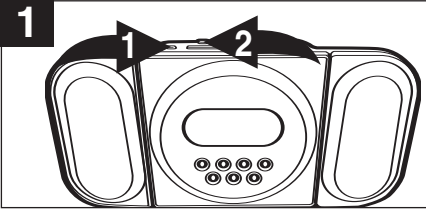

FIGURE 4

CAUTION: Only connect the speakers which are supplied with the unit. The use of any other or additional speakers may cause damage to the unit. Never operate the unit without the speakers connected.

OPERATION

TO LISTEN TO THE RADIO



Press the POWER button ❶ to turn the unit on. Press the RADIO/BAND button ❷ to select radio. Repeatedly press the RADIO/BAND button ❷ to select AM or FM.

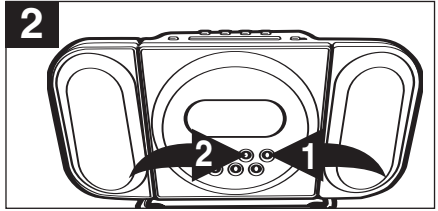

MANUAL TUNING: Repeatedly press the Tune/Skip/Search/Min ►► ❶ or Hr ◀◀ ❷ button to manually advance the frequency in the display up or down until the desired frequency appears. The display will revert back to the time display after a few seconds.

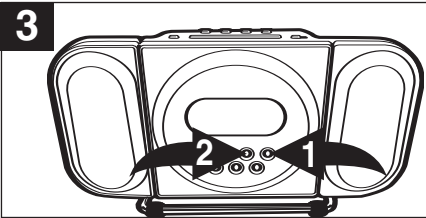

AUTOMATIC TUNING: Press and hold the Tune/Skip/Search/Min ►► ❶ or Hr ◀◀ ❷ button until the frequency in the display starts to scan, and then release the button; the tuner will search and then stop on the next strong station it finds. Repeat this step until the desired frequency appears in the display. The display will revert back to the time display after a few seconds.

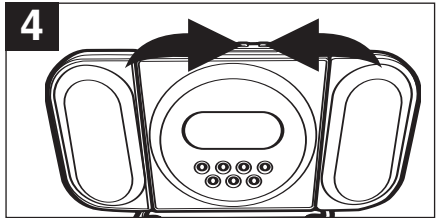

Adjust the VOLUME buttons as desired. When listening to an FM radio station that is broadcasting in Stereo, the Stereo (◫) indicator will appear. If the radio broadcast is not strong enough or not in stereo, the Stereo (◫) indicator will not appear in the display.

Antennas

FM: Unravel and extend the FM antenna wire for best reception.

AM: Turn the unit for better AM reception.

OPERATION (CONTINUED)

RADIO PRESETS—Up to 5 AM and 5 FM

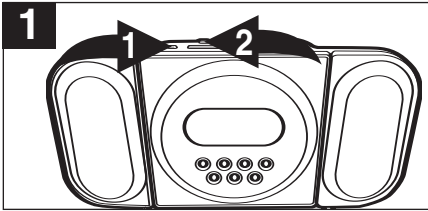

Press the **POWER** button ❶ to turn the unit on. Press the **RADIO/BAND** button ❷ to select radio. Repeatedly press the **RADIO/BAND** button ❷ to select AM or FM.

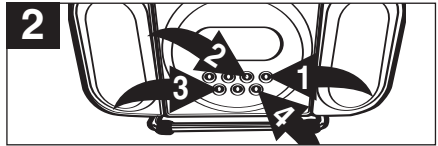

Select a station using the **Tune/Skip/Search/Min** ❶ or **Hr** ❷ buttons. Press the **PROG./CH SAVE** button ❸; the preset number will blink in the display. Within three seconds, press the **MODE/CH+/ALARM SELECT** button ❹ until the desired memory number appears on the display.

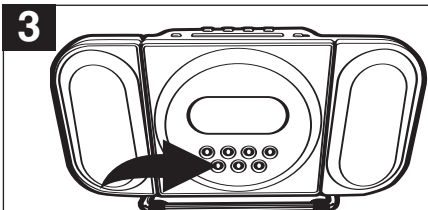

Press the **PROG./CH SAVE** button again to set the station in the selected memory.

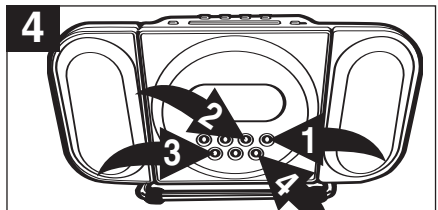

Repeat steps 2 and 3 to program up to 5 stations in each band, if desired.
TO RECALL: Follow step 1 above. Repeatedly press the **MODE/CH+/ALARM SELECT** button to select a preset; the station will automatically be tuned in.

INSERTING A CD

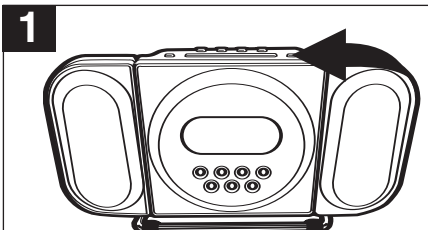

Slide the **DOOR OPEN** switch to the right and the CD door will open, then gently pull out the CD door. **Gently** insert a CD onto the spindle (label side facing forward) until it clicks. Close the CD door.

OPERATION (CONTINUED)

TO PLAY A CD

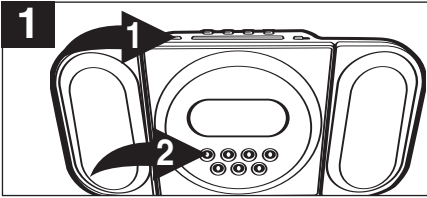

Press the POWER button ❶ to turn the unit on and insert a CD as described on the previous page. Press the Play/Pause (▶||)/CD button ❷ to select CD; the total number of tracks and playing time will appear in the display, then playback will start automatically.

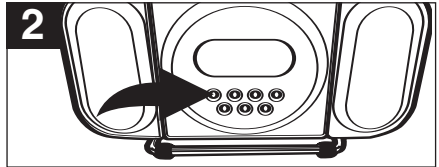

If in the Stop mode, press the Play/Pause (▶||)/CD button to start playback. **TO PAUSE PLAYBACK**, press the Play/Pause (▶||)/CD button again; the elapsed track time will blink in the display for a few seconds, then the time will appear and the track number will blink. Press again to resume playback.

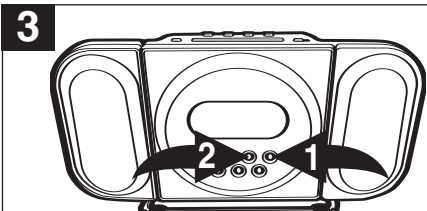

To **skip** forward or backward through the tracks on the disc, press the Tune/Skip/Search/Min ►► ❶ or Hr ◀◀ ❷ button. To **search** forward or backward through the tracks on the disc, press and hold the Tune/Skip/Search/Min ►► ❶ or Hr ◀◀ ❷ button.

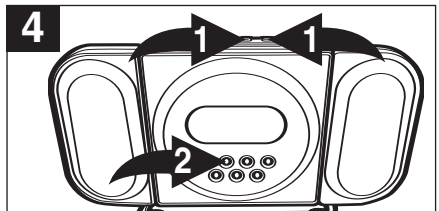

Adjust the VOLUME buttons ❶ as desired. When the disc is through playing, it will stop. Press the STOP (■)/CLOCK SET BUTTON ❷ to stop the disc before it is finished.

FAQS: *Do I need an adapter to play 3" singles?*
No, simply insert the 3" single into the groove.
What is the maximum time for a CD in this unit?
The maximum time is 74 minutes.

NOTES:

- If a disc is inserted incorrectly, dirty, damaged or not present at all, the display will show, "NO DISC".
- When you press the Tune/Skip/Search/Min ►► or Hr ◀◀ button or the Pause button, the track elapsed time will appear for a few seconds then revert back to the time display and the track number will appear.

OPERATION (CONTINUED)

TO REPEATEDLY PLAY BACK ONE TRACK

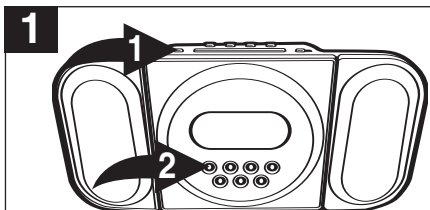

Press the **POWER** button ❶ to turn the unit on and insert a CD as described on page 9. Press the **Play/Pause (▶||)/CD** button ❷ to select CD; the total number of tracks and playing time will appear in the display, then playback will start automatically.

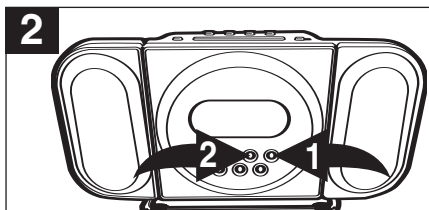

Press the **Tune/Skip/Search/Min** ❷ or **Hr** ❶ button to select a track to repeat.

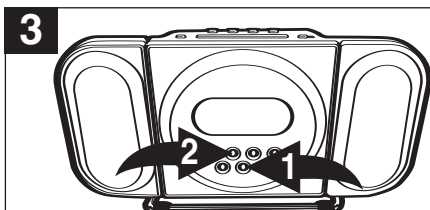

Press the **REPEAT/ALARM 1/2 SET** Button ❶ once; “REP” will appear in the display and the unit will play the same track over and over until the **Stop (■)/CLOCK SET** Button ❷ is pressed.

TO REPEATEDLY PLAY BACK ALL TRACKS

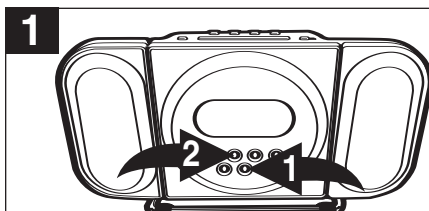

Follow step 1 above. Press the **REPEAT/ALARM 1/2 SET** Button ❶ twice; “REP ALL” will appear in the display and the unit will play all the tracks on the CD over and over until the **Stop (■)/CLOCK SET** Button ❷ is pressed.

TO CANCEL REPEAT MODE, press the **REPEAT** button until the Repeat indicator disappears from the display.

OPERATION (CONTINUED)

TO PROGRAM THE MEMORY (UP TO 20 TRACKS)

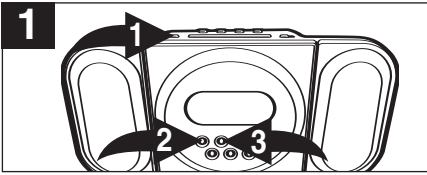

Press the POWER button ❶ to turn the unit on and insert a CD as described on page 9. Press the Play/Pause (▶||)/CD button ❷ to select CD; the total number of tracks and playing time will appear in the display, then playback will start automatically. Press the STOP (■)/CLOCK SET BUTTON ❸ to stop automatic playback.

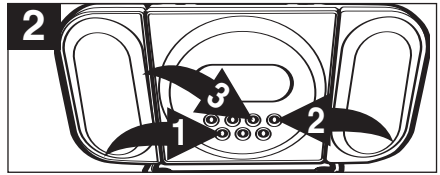

Press the PROG./CH SAVE button ❶ once; "P 01" (program number), "00" track number and the Program indicator will appear in the display. Select the first track to be played back using the Tune/Skip/Search/Min ▶▶ ❷ or Hr ◀◀ ❸ button, then press the PROG./CH SAVE button ❶ again. Repeat this step to program additional tracks, up to 20 tracks.

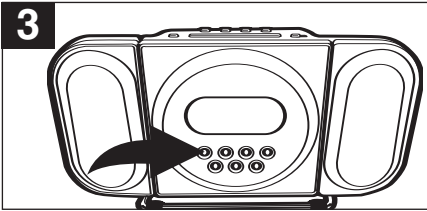

Press the PLAY/PAUSE (▶||)/CD button to begin playback. The unit will play all the tracks in the order you programmed them.

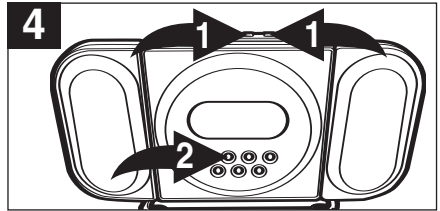

Adjust the VOLUME buttons ❶ as desired. When the disc is through playing, it will stop. Press the STOP (■)/CLOCK SET BUTTON ❷ to stop the disc before it is finished.

NOTES:

- To skip forward or backward through the programs, press the Tune/Skip/Search/Min ▶▶ or Hr ◀◀ button. When the disc is through playing, it will stop.
- Programming is the ability to preselect the order in which a series of tracks will be played.

FAQ: *How do I clear the memory and exit the program playback mode?*
While in the program stop mode, press the STOP (■)/CLOCK SET BUTTON to clear the program and exit the program mode. The display will show the total tracks and time of the disc again.

OPERATION (CONTINUED)

RANDOM PLAYBACK

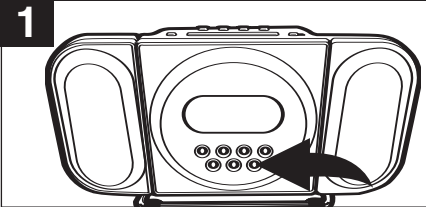

To play the tracks on the CD in a random order, while in the Stop mode, press the MODE/CH+/ALARM SELECT button once and "RAND" will appear in the display.

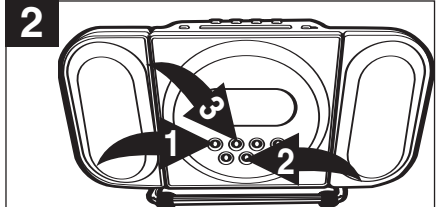

Press the PLAY/PAUSE (▶||)/CD button ❶. The unit will randomly play each track on the CD and then stop. If you want to randomly playback the tracks repeatedly, press the REPEAT/ALARM 1/2 SET Button ❷ twice during random playback. To cancel and stop Random or Random Repeat playback, press the STOP (■)/CLOCK SET BUTTON ❸; the "REP ALL" and "RAND" indicators will disappear from the display.

INTRO PLAYBACK

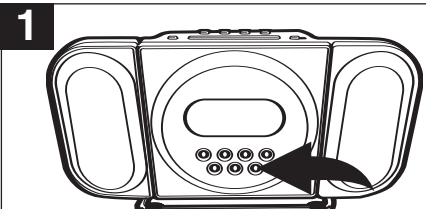

To play the first 10 seconds of each track on the CD, while in the Stop mode, press the MODE/CH+/ALARM SELECT button repeatedly until "INTRO" appears in the display.

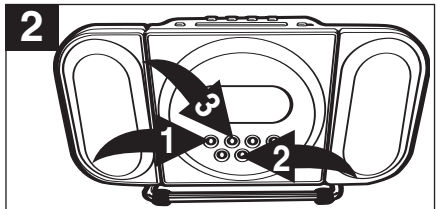

Press the PLAY/PAUSE (▶||)/CD button ❶. The unit will play the first 10 seconds of each song and then stop. If you want to playback the first ten seconds of the tracks repeatedly, press the REPEAT/CLOCK/ALARM SET button ❷ twice during INTRO playback. To cancel and stop INTRO playback or INTRO Repeat playback, press the STOP (■)/CLOCK SET BUTTON ❸; the "REP ALL" and "INTRO" indicators will disappear from the display.

OPERATION (CONTINUED)

TO SET OR RESET THE ACTUAL TIME

1

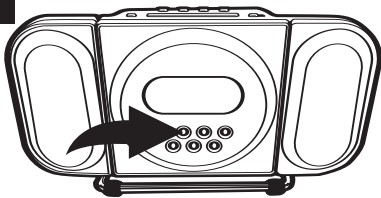

With the power off, press the STOP (■)/CLOCK SET BUTTON; the time will blink.

2

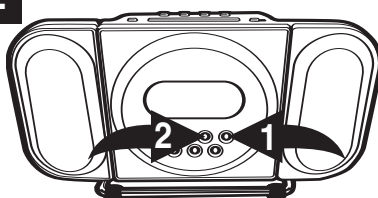

Press the Tune/Skip/Search/Min **1** button to set the present minute and the Tune/Skip/Search/Hr **2** button to set the present hour. Make sure to set the correct AM/PM setting.

3

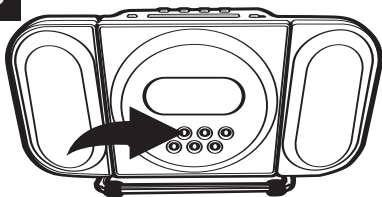

Press the STOP (■)/CLOCK SET BUTTON and the time will be set.

OPERATION (CONTINUED)

TO SET OR RESET THE ALARM TIME

1

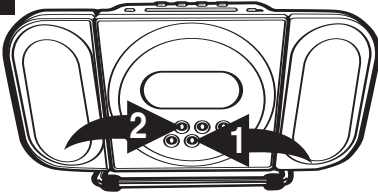

With the power off, press the REPEAT/CLOCK/ALARM SET button ❶ repeatedly; the alarm time and Alarm 1 or Alarm 2 indicator will appear. Select Alarm 1 or Alarm 2, then press the STOP (■)/CLOCK SET BUTTON ❷; the alarm time will blink.

2

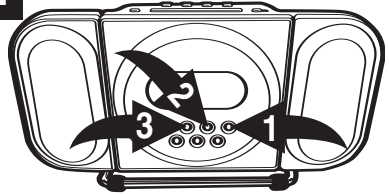

Press the Tune/Skip/Search/Min ► button ❶ to set the alarm minute and the Tune/Skip/Search/Hr ◀ button ❷ to set the alarm hour. Press the STOP (■)/CLOCK SET BUTTON ❸ to confirm. Make sure to set the correct AM/PM setting.

3

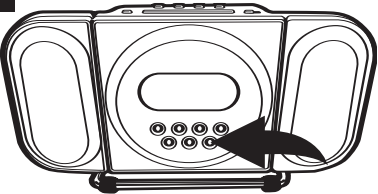

Repeatedly press the MODE/CH+/ALARM SELECT button to select the alarm type: Buzzer (⊙), Radio (□) or CD (⊙).

4



If set to CD, set the track number using the VOLUME buttons.
NOTE: Make sure the CD is read/played before setting the Alarm function.

OPERATION (CONTINUED)

5

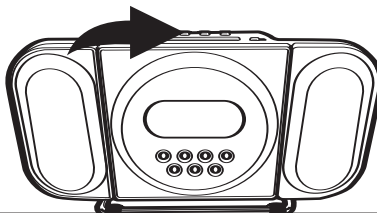

Press the ALARM 1/2 ON/OFF button to activate the alarm; the selected alarm indicator(s) will light. Make sure the volume is set as desired and, if set to Radio, make sure to tune a station. If set to CD, insert a CD before setting the alarm time. When the actual time matches the selected preset alarm time(s), the unit automatically turns on for 59 minutes and then shuts off. If set to CD, and the total disc time is less than 59 minutes, the unit will only play the tracks on the CD, then stop. If you select a starting track for the alarm, the unit will only playback the selected track and the tracks following it, then stop.

TO SHUT OFF THE ALARM, see TO SHUT THE ALARM OFF section on the next page.

OPERATION (CONTINUED)

TO SHUT THE ALARM OFF

1

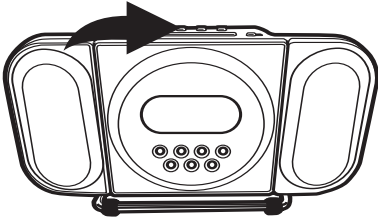

To shut the alarm off, press the ALARM 1/2 ON/OFF button until the selected alarm indicator(s) appears in the display and the alarm time will be reset for the next day. Press the ALARM 1/2 ON/OFF button so the alarm indicators disappear from the display to turn off the alarm and not set it for the next day.

SNOOZE

1

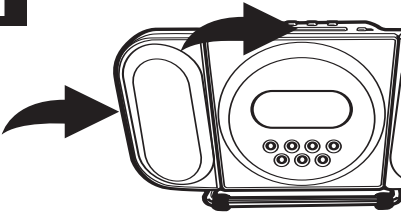

The alarm can be temporarily turned off manually by pressing the SNOOZE button, either on top of the unit or on the side of the left speaker; the Snooze indicator (Z) will blink and the alarm will turn back on automatically 10 minutes later. It can be repeated endlessly.

NOTE:

- When setting the alarm, if no button is pressed within 10 seconds, the display will revert back to the current time.

CARE AND MAINTENANCE

Caring for Compact Discs

- Treat the disc carefully. Handle the disc only by its edges. Never allow your fingers to come in contact with the shiny, unprinted side of the disc.
- Do not attach adhesive tape, stickers, etc. to the disc label.
- Clean the disc periodically with a soft, lint-free, dry cloth. Never use detergents or abrasive cleaners to clean the disc. If necessary, use a CD cleaning kit.
- If a disc skips or gets stuck on a section of the disc, it is probably dirty or damaged (scratched).
- When cleaning the disc, wipe in straight lines from the center of the disc to the outer edge of the disc. Never wipe in circular motions.

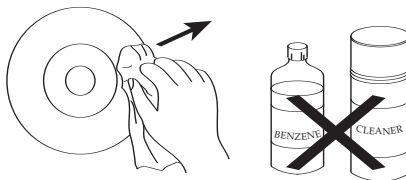
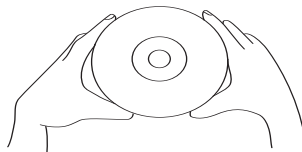

- This unit is designed to play only discs bearing the identification logo as shown here. Other discs may not conform to the CD standard and may not play properly.
- Discs should be stored in their cases after each use to avoid damage.
- Do not expose discs to direct sunlight, high humidity, high temperatures or dust, etc. Prolonged exposure or extreme temperatures can warp the disc.
- Do not stick or write anything on either side of the disc. Sharp writing instruments, or the ink, may damage the surface.



Cleaning the Unit

- To prevent fire or shock hazard, disconnect your unit from the AC power source when cleaning.
- The finish on your unit may be cleaned with a dust cloth and cared for as other furniture. Use caution when cleaning and wiping the plastic parts.
- Mild soap and a damp cloth may be used on the front panel.

TROUBLESHOOTING GUIDE

If you experience a problem with this unit, check the chart below before calling for service.

SYMPTOM	CAUSE	SOLUTION
Unit will not turn on.	AC adapter is not connected.	Check the AC adapter connection.
Disc will not play.	CD compartment door not closed.	Close CD compartment door.
	Disc inserted incorrectly.	Reinsert disc correctly.
	Dirty or defective CD.	Try another disc.
	Moisture condensation on disc.	Wipe disc with soft cloth.
No sound.	VOLUME setting is set to minimum.	Increase volume.
	Defective disc.	Try another disc.
Erratic playback.	Dirty or defective disc.	Clean or replace disc.
Time reset to "12:00".	Battery connected improperly, not connected or dead.	Check the battery.
	Clock not set.	Set the clock.
Alarm does not turn on.	Alarm is not activated or set properly.	Set and activate alarm as described on page 15.
	Clock is not set.	Set the clock.
	Alarm is not set.	Set the alarm.
AM or FM, no sound.	Power is not on.	Press the POWER button to turn the unit on.
	VOLUME setting is set to minimum.	Increase volume.

SPECIFICATIONS

AUDIO

Frequency Range (AM)520–1710KHz
Frequency Range (FM).....87.5–108MHz

CD SECTION:

Disc Diameter4.72" (120mm)
3.15" (80mm) Single CD
Optical Source.....Semiconductor Laser
Wavelength780nm

GENERAL

Power SupplyDC IN Jack 6V, Center Positive
Battery Backup 2 x 1.5V "AAA" size batteries

FOR ADDITIONAL SET-UP OR OPERATING ASSISTANCE, PLEASE VISIT OUR WEBSITE AT

WWW.MEMOREXELECTRONICS.COM

OR CONTACT CUSTOMER SERVICE AT 1-800-919-3647.

PLEASE KEEP ALL PACKAGING MATERIAL FOR AT LEAST 90 DAYS IN CASE YOU NEED TO RETURN THIS PRODUCT TO YOUR PLACE OF PURCHASE OR MEMOREX.

FOR PARTS AND ACCESSORIES, CONTACT FOX INTERNATIONAL AT 1-800-321-6993.

Memcorp, Inc.
Weston, FL
Printed in Hong Kong

Visit our website at www.memorexelectronics.com