

Clarion

Owner's manual
Mode d'emploi
Manual de instrucciones

DXZ745MP

AM / FM CD / MP3 / WMA PLAYER

RADIO AM/FM-LECTEUR CD/MP3/WMA

REPRODUCTOR DE AM/FM CD/MP3/WMA

ProAudio **ceNET**

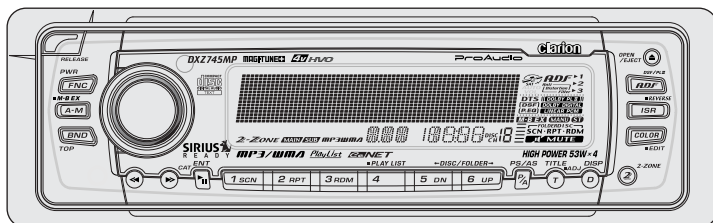

40 HVO

**COMPACT
disc
DIGITAL AUDIO
TEXT**

**SIRIUS
R E A D Y**

Plays
**Windows
Media™**

Thank you for purchasing this **Clarion** product.

Please read this owner's manual in its entirety before operating this equipment.

After reading this manual, be sure to keep it in a handy place (e.g., glove compartment).

Check the contents of the enclosed warranty card and keep it carefully with this manual.

This manual includes the operating procedures of the CD changer, SIRIUS and TV tuner, BB. DTS/AC3 connected via the CeNET cable. The CD changer and TV tuner have their own manuals, but no explanations for operating them are described.

Contents

1. FEATURES	2
2. PRECAUTIONS	3
Motorized Face	4
Handling Compact Discs	4
3. CONTROLS	5
4. NOMENCLATURE	6
Names of the Buttons and Their Functions	6
Major Button Operations When External Equipment is Connected to This Unit	7
Display Items	8
LCD Screen	8
5. DCP	9
6. REMOTE CONTROL	10
Inserting the Batteries	10
Functions of Remote Control Unit Buttons	11
7. OPERATIONS	12
Basic Operations	12
Radio Operations	14
CD/MP3/WMA Operations	16
Different pieces of music heard by plural listeners (2-ZONE function)	21
Operations Common to Each Mode	22
8. OPERATIONS OF ACCESSORIES	26
CD Changer Operations	26
TV Operations	28
Connect with 5.1ch Surround Decoder (DVH920/DVH940)	30
9. IN CASE OF DIFFICULTY	32
10. ERROR DISPLAYS	34
11. SPECIFICATIONS	35

1. FEATURES

- MP3 and WMA File Playable with ID3-TAG and WMA-TAG Display
- Motorized Fold Down Detachable Faceplate in Aluminum with Negative/Positive Reversible 728-Variable Color LCD and Control Buttons
- ADF(Anti Distortion Filter)
- 24 Bit Digital to Analogue Converter for Audiophile
- 4 V/ 6ch Gold Plated RCA Output and 2ch RCA AUX Input with 3 Level Adjustments
- Retractable Volume Control for Easy Operation
- Sirius Control
- 5.1ch Decoder Control

2. PRECAUTIONS

1. When the inside of the car is very cold and the player is used soon after switching on the heater moisture may form on the disc or the optical parts of the player and proper playback may not be possible. If moisture forms on the disc, wipe it off with a soft cloth. If moisture forms on the optical parts of the player, do not use the player for about one hour. The condensation will disappear naturally allowing normal operation.
2. Driving on extremely bumpy roads which cause severe vibration may cause the sound to skip.
3. This unit uses a precision mechanism. Even in the event that trouble arises, never open the case, disassemble the unit, or lubricate the rotating parts.

This equipment has been tested and found to comply with the limits for a Class B digital device, pursuant to Part 15 of the FCC Rules.

These limits are designed to provide reasonable protection against harmful interference in a residential installation.

This equipment generates, uses, and can radiate radio frequency energy and, if not installed and used in accordance with the instructions, may cause harmful interference to radio communications. However, there is no guarantee that interference will not occur in a particular installation.

If this equipment does cause harmful interference to radio or television reception, which can be determined by turning the equipment off and on, the user is encouraged to consult the dealer or an experienced radio/TV technician for help.

⚠ CAUTION

USE OF CONTROLS, ADJUSTMENTS, OR PERFORMANCE OF PROCEDURES OTHER THAN THOSE SPECIFIED HEREIN, MAY RESULT IN HAZARDOUS RADIATION EXPOSURE.

THE COMPACT DISC PLAYER and MINI DISC PLAYER SHOULD NOT BE ADJUSTED OR REPAIRED BY ANYONE EXCEPT PROPERLY QUALIFIED SERVICE PERSONNEL.

CHANGES OR MODIFICATIONS NOT EXPRESSLY APPROVED BY THE MANUFACTURER FOR COMPLIANCE COULD VOID THE USER'S AUTHORITY TO OPERATE THE EQUIPMENT.

INFORMATION FOR USERS:

CHANGES OR MODIFICATIONS TO THIS PRODUCT NOT APPROVED BY THE MANUFACTURER WILL VOID THE WARRANTY AND WILL VIOLATE FCC APPROVAL.

MODEL	<input type="text"/>	Clarion
12V ⚡ GROUND		
AM 530-1710kHz/FM 87.9-107.9MHz		
<p>THIS DEVICE COMPLIES WITH PART 15 OF THE FCC RULES. OPERATION IS SUBJECT TO THE FOLLOWING TWO CONDITIONS: (1) THIS DEVICE MAY NOT CAUSE HARMFUL INTERFERENCE, AND (2) THIS DEVICE MUST ACCEPT ANY INTERFERENCE RECEIVED, INCLUDING INTERFERENCE THAT MAY CAUSE UNDESIRE OPERATION.</p>		
<p>THIS PRODUCTION COMPLIES WITH DHHS RULES 21 CFR SUBCHAPTER J APPLICABLE AT DATE OF MANUFACTURE.</p>		
<p>CLARION CO., LTD. 50 KAMITODA, TODA-SHI, SAITAMA-KEN, JAPAN</p>		
<p>This product includes technology owned by Microsoft Corporation and cannot be used or distributed without a license from MSLGP.</p>		
MANUFACTURED:		
SERIAL No.	<input type="text"/>	286- <input type="text"/>
PE- <input type="text"/>		Clarion Co., Ltd. MADE IN CHINA

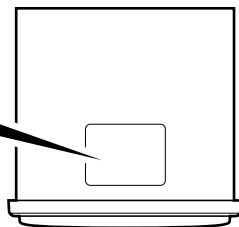

Bottom View of Source Unit

Motorized Face

This unit uses motorized face to make large-screen displays possible.

When you use the motorized face, be sure to close it.

⚠ CAUTION

BE CAREFUL NOT TO GET YOUR FINGERS CAUGHT WHEN OPENING AND CLOSING THE MOTORIZED FACE.

1. For safety's sake, always close the MOTORIZED FACE before leaving this unit unused for a prolonged period or switching OFF the ignition key.

If you switch OFF the ignition key with the MOTORIZED FACE tilted, the MOTORIZED FACE does not close.

2. Before the MOTORIZED FACE closes, there may be a braking sound from the safety mechanism. This is normal.

3. If you move the MOTORIZED FACE by hand, this may create play. To correct this play, with the power on for the unit, press the [▲] button to close the MOTORIZED FACE.
4. After a disc is ejected, the MOTORIZED FACE automatically returns to the tilted or closed state. If there is any obstruction when the MOTORIZED FACE tries to close, the safety mechanism is triggered and the MOTORIZED FACE returns to the open state. If this happens, remove the obstruction, then press the [▲] button.
5. To avoid scratching the compact disk, keep the 12 or 8 cm CD level when inserting or removing them.

Handling Compact Discs

Use only compact discs bearing the  mark.

Do not play heart-shaped, octagonal, or other specially shaped compact discs.

Some CDs recorded in CD-R/CD-RW mode may not be usable.

Handling

- Compared to ordinary music CDs, CD-R and CD-RW discs are both easily affected by high temperature and humidity and some of CD-R and CD-RW discs may not be played. Therefore, do not leave them for a long time in the car.

- New discs may have some roughness around the edges. If such discs are used, the player may not work or the sound may skip. Use a ball-point pen or the like to remove any roughness from the edge of the disc.

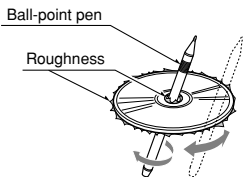

- Never stick labels on the surface of the compact disc or mark the surface with a pencil or pen.
- Never play a compact disc with any cellophane tape or other glue on it or with peeling off marks. If you try to play such a compact disc, you may not be able to get it back out of the CD player or it may damage the CD player.

- Do not use compact discs that have large scratches, are misshapen, cracked, etc. Use of such discs may cause misoperation or damage.
- To remove a compact disc from its storage case, press down on the center of the case and lift the disc out, holding it carefully by the edges.
- Do not use commercially available CD protection sheets or discs equipped with stabilizers, etc. These may damage the disc or cause breakdown of the internal mechanism.

Storage

- Do not expose compact discs to direct sunlight or any heat source.
- Do not expose compact discs to excess humidity or dust.
- Do not expose compact discs to direct heat from heaters.

Cleaning

- To remove fingermarks and dust, use a soft cloth and wipe in a straight line from the center of the compact disc to the circumference.
- Do not use any solvents, such as commercially available cleaners, anti-static spray, or thinner to clean compact discs.
- After using special compact disc cleaner, let the compact disc dry off well before playing it.

Be sure to unfold and read the next page. / Veuillez déplier et vous référer à la page suivante.
Cerciórese de desplegar y de leer la página siguiente.

3.CONTROLS / LES COMMANDES / CONTROLES

English

Français

Español

Source unit / Appareil pilote / Unidad fuente

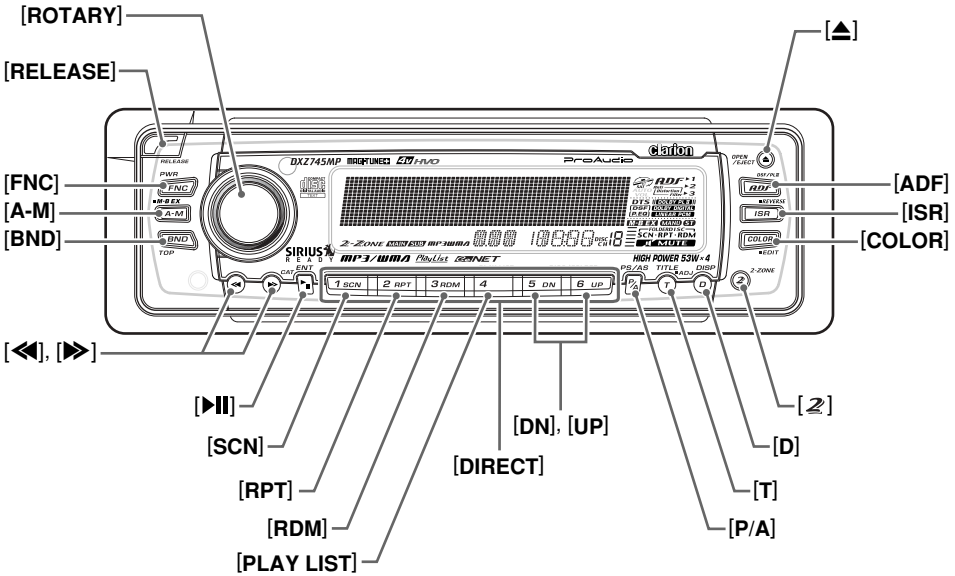

With the SLOPING CONSOLE opened / Ouvrez la CONSOLE RABATTABLE
 Apertura de la CONSOLA INCLINABLE

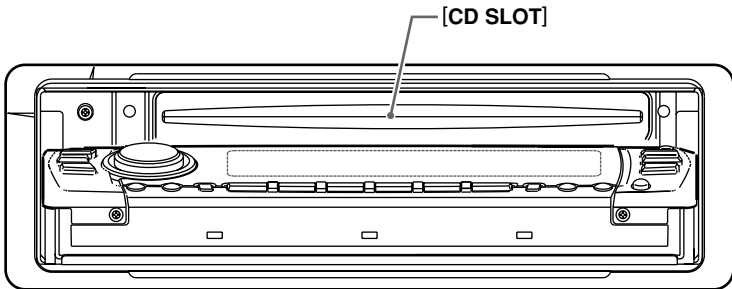

Note: Be sure to unfold this page and refer to the front diagrams as you read each chapter.
 Remarque: Veuillez déplier cette page et vous référer aux schémas quand vous lisez chaque chapitre.
 Nota: Cuando lea los capítulos, despliegue esta página y consulte los diagramas.

4. NOMENCLATURE

Note:

- Be sure to read this chapter referring to the front diagrams of chapter "3. CONTROLS" on page 5 (unfold).

Names of the Buttons and Their Functions

[RELEASE] button

- Deeply push in the button to unlock the DCP.

[ROTARY] knob

- Adjust the volume by turning the knob clockwise or counterclockwise.
- Use the knob to perform various settings.

[▲] button

- Press to eject a CD loaded in the unit.
- Press to open the CD slot and insert a CD.

[ADF] button

- Use the button to select one of the 4 types of sound characteristics already stored in memory.

[ISR] button

- Recall ISR radio station in memory.
- Press and hold for 2 seconds or longer: Store current station into ISR memory (radio mode only).
- Press and hold the button for 1 second or longer to switch the main and sub zone sound source. (only while 2-ZONE mode on).

[COLOR] button

- Button's color change to multicolor.

[Z] button

- Press and hold for 1 second or longer to turn on or off the 2-ZONE mode.
- Press to switch the control zone between main zone or sub zone while 2-ZONE mode on.

[D] button

- Switch the display indication (Main display, Clock display).

[T] button

- Use the button to input a title in the radio, CD mode.
- Press and hold the button for 1 second or longer to enter the adjust mode.

[P/A] button

- Perform preset scan while in the radio mode. When the button is pressed and held, auto store is performed.

[UP], [DN] buttons

- Select the folder while in the MP3/WMA mode.

[DIRECT] buttons

- Store a station into memory or recall it directly while in the radio mode.

[PLAY LIST] button

- Press and hold for 1 second or longer to turn on or off the play list mode. (MP3/WMA disc only)

[RDM] button

- Perform random play while in the CD/MP3/WMA mode.
- Press and hold the button for 1 second or longer to perform folder random play while in the MP3/WMA mode.

[RPT] button

- Repeat play while in the CD/MP3/WMA mode.
- Press and hold the button for 1 second or longer to perform folder repeat play while in the MP3/WMA mode.

[SCN] button

- Perform scan play for 10 seconds of each track while in the CD/MP3/WMA mode.
- Press and hold the button for 1 second or longer to perform folder scan play while in the MP3/WMA mode.

[▶||] button

- Play or pause a CD while in the CD/MP3 mode.

[◀], [▶▶] buttons

- Select a station while in the radio mode or select a track when listening to a CD. These buttons are used to make various settings.
- Press and hold the button for 1 second or longer to switch the fast-forward/fast-backward.

[BND] button

- Switch the band, or seek tuning or manual tuning while in the radio mode.
- Play a first track while in the CD/MP3/WMA mode.

[A-M] button

- Use the button to switch to the audio mode (bass/treble, balance/fader ADF, Magna Bass Extended adjustment)
- Press and hold for 1 second or longer to turn on or off the M-B EX mode.

[FNC] button

- Press the button to turn on the power. Press and hold the button for 1 second or longer to turn off the power.
- Switch the operation mode among the radio mode, etc.

[CD SLOT]

- CD insertion slot.

Major Button Operations When External Equipment is Connected to This Unit

● When the CD/DVD changer is connected

For details, see the section “CD Changer Operations”. For the DVD changer, refer to the Owner’s Manual provided with the DVD changer.

[D] button

- When the button is pressed and held, switches the user titles or track titles, etc. while in the CD changer mode.

[T] button

- Use the button to input a title in the CD changer mode.
- Use the button to scroll the title during CD-text play.

[UP], [DN] buttons

- Select the disc.

[RDM] button

- Perform random play. Also perform disc random play when the button is pressed and held.

[RPT] button

- Perform repeat play. When this button is pressed and held, disc repeat play is performed.

[BND] button

- Move the next disc in increasing order.

[SCN] button

- Perform scan play for 10 seconds of each track. Disc scan play is performed when the button is pressed and held.

[▶II] button

- Play or pause a CD or DVD.

[◀◀], [▶▶] buttons

- Select a track when listening to a disc.
- Press and hold the button for 1 second or longer to switch the fast-forward/fast-backward.

● When the DTS/DOLBY DIGITAL is connected (DVH940)

[ADF] button

- Press the button to turn on the DSF.
- Press the button to turn on the PLII while the DSF on.

[◀◀], [▶▶] buttons

- Press the button to change the DSF mode while the DSF mode is on.
- Press the button to change the PLII mode while the PLII mode is on.

● When the TV is connected

For details, see the section “TV Operations”.

[P/A] button

- Perform preset scan while in the TV mode. When the button is pressed and held, auto store is performed.

[▶II] button

- Switch the TV picture mode or VTR (external) picture mode.

[DIRECT] buttons

- Store a station into memory or recall it directly.

[◀◀], [▶▶] buttons

- Select a station.

[BND] button

- Switch the band.
- When the button is pressed and held, switch seek tuning or manual mode.

● When the Sirius Satellite Radio is connected

For details, refer to the Owner’s Manual provided with the Sirius Satellite Radio.

[FNC] button

- Press the button to switch the operation mode among the SIRIUS mode, etc.

[▶II] button

- Select the CAT (Category) while in the SIRIUS radio mode.

[DIRECT] buttons

- Stores a station into memory or recall it directly while in the SIRIUS mode.

[◀◀], [▶▶] buttons

- Press the button to selects a station.

Major Button Operations When External Equipment is Connected to This Unit

What is Sirius Satellite Radio? **SIRIUS** READY

Sirius is radio the way it was meant to be: Up to 100 new channels of digital quality programming delivered to listeners coast to coast via satellite. That means 50 channels of completely commercial-free music. Plus up to 50 more channels of news, sports, and entertainment from names like CNBC, Discovery, SCI-FI Channel, A&E, House of Blues, E!, NPR, Speedvision and ESPN.

Sirius is live, dynamic entertainment, completely focused on listeners. Every minute of every day of every week will be different. All 50 commercial-free music channels are created in-house and hosted by DJs who know and love the music. Do you like Reggae? How about

Classic Rock or New Rock? Sirius has an array of choices spanning a vast range of musical tastes including the hits of the 50's, 60's, 70's, & 80's as well as Jazz, Country, Blues, Pop, Rap, R&B, Bluegrass, Alternative, Classical, Heavy Metal, Dance and many others...

From its state-of-the-art, digital broadcasting facility in Rockefeller Center, New York City, Sirius will deliver the broadest, deepest mix of radio entertainment from coast to coast.

Sirius will bring you music and entertainment programming that is simply not available on traditional radio in any market across the country. It's radio like you've never heard before.

So Get Sirius and Listen Up! For more information, visit siriusradio.com.

Display Items

The diagram shows a car stereo LCD screen with several callouts pointing to specific display elements:

- Operation status indication**: Titles, clock, etc. are displays.
- Function mode indication**: The names of modes being selected, etc. are displayed.
- Preset channel indication (1 to 6)**: Indicated by small icons on the screen.
- Disc number indication (1 to 12)**: Indicated by a 'DISC' label and a number.

The screen itself displays the following information:

- 2-ZONE**: 2-ZONE indication
- MAIN**: Main indication
- SUB**: Sub indication
- MP3**: MP3 indication
- WMA**: WMA indication
- ST**: Stereo indication
- FOLDER**: Folder indication
- DISC**: Disc indication
- SCN**: Scan indication
- RPT**: Repeat indication
- RDM**: Random indication
- MUTE**: Mute indication
- SAT**: Satellite indication
- ADF**: Anti Distortion Filter indication
- DTS**: DTS indication
- DSF**: DSF indication
- P.EQ**: P.EQ indication
- (DOLBY PL II)**: DOLBY PL II indication
- DOLBY DIGITAL**: DOLBY DIGITAL indication
- LINEAR PCM**: LINEAR PCM indication
- M-B EX**: MAGNA BASS EXTEND indication
- MANU**: Manual indication

LCD Screen

In extreme cold, the screen movement may slow down and the screen may darken, but this is normal. The screen will recover when it returns to normal temperature.

5. DCP

The control panel can be detached to prevent theft. When detaching the control panel, store it in the DCP (DETACHABLE CONTROL PANEL) case to prevent scratches.

We recommend taking the DCP with you when leaving the car.

Removing the DCP

1. With the MOTORIZED FACE closed, turn off the power.
2. Press the [RELEASE] button deeply to open the DCP.

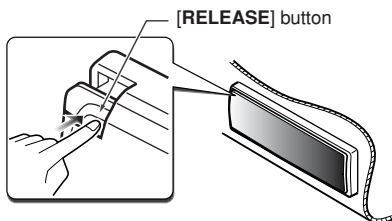

3. Pull the DCP toward you and remove it.

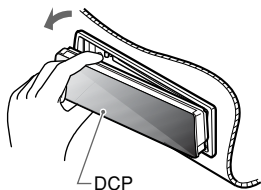

CAUTION

- Always close the MOTORIZED FACE before removing the DCP.
- If you remove the DCP with the MOTORIZED FACE open, the MOTORIZED FACE closes immediately. Be careful not to get your fingers caught.

Attaching the DCP

1. Insert the DCP so that the (A) section on the right side of the DCP catches on the hook (B) on the unit.

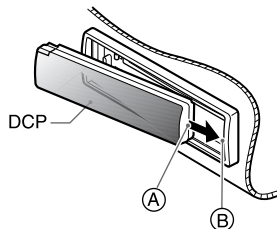

2. Press the left side (C) of the DCP carefully to fit it in place.

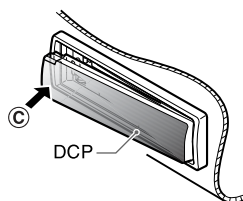

CAUTION

- The DCP can easily be damaged by shocks. After removing it, be careful not to drop it or subject it to strong shocks.
- If the [RELEASE] button is pressed and the DCP is not locked into place, it may fall out from vibration of the car. This can break the DCP, so after removing it, either install it on the unit or put it in its DCP case.
- The connector connecting the unit and the DCP is an extremely important part. Be careful not to damage it by pressing on it with fingernails, screwdrivers, etc.

Note:

- If the DCP is dirty, wipe off the dirt with a soft, dry cloth only.

6. REMOTE CONTROL

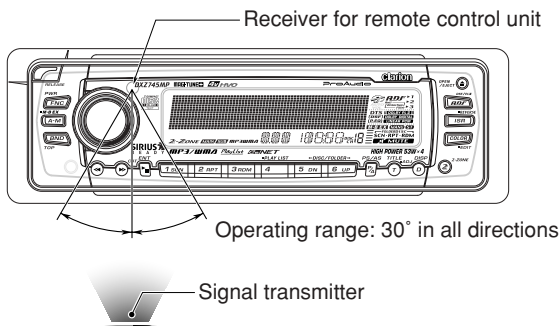

Remote control unit

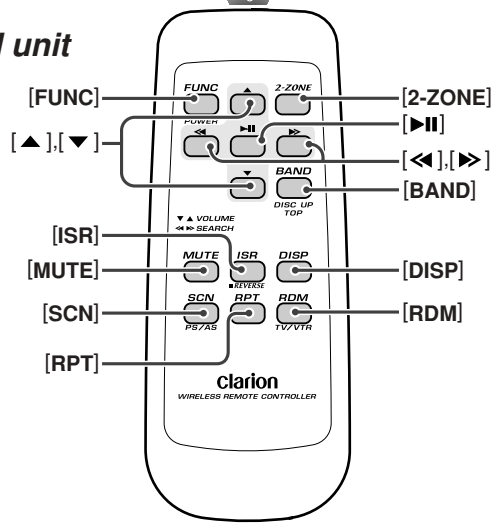

Inserting the Batteries

1. Turn the remote control unit over, then slide the rear cover in the direction of the arrow.
2. Insert the AA (SUM-3, IECR-6/1.5V) batteries that came with the remote control unit facing in the directions shown in the figure, then close the rear cover.

Notes:

Using batteries improperly can cause them to explode. Take note of the following points:

- When replacing batteries, replace both batteries with new ones.
- Do not short-circuit, disassemble or heat batteries.
- Do not dispose of batteries into fire or flames.
- Dispose of spent batteries properly.

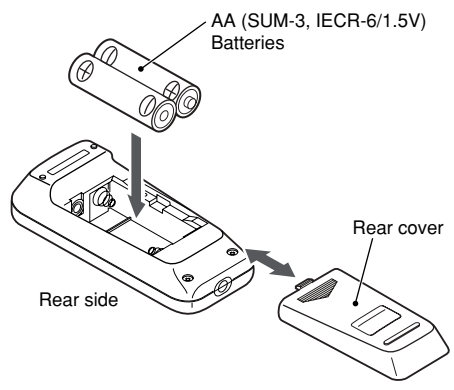

Functions of Remote Control Unit Buttons

Mode Button	Radio/SIRIUS	CD/MP3/WMA	CD changer DVD changer	TV
[FUNC]	Switches among radio, SIRIUS tuner, CD/MP3/WMA, CD changer, DVD changer, TV and AUX.			
[BAND]	Switches reception band.	Plays the first track. Top play.	Moves the next disc in increasing order.	Switches reception band.
[▲], [▼]	Increases and decreases volume (in all modes).			
[◀], [▶]	Moves preset channels up and down.	Moves tracks up and down. When pressed and held for 1 second: Fast-forward/fast-backward.		Moves preset channels up and down.
[▶]	No function.	Switches between playback and pause.		No function.
[MUTE]	Turns mute on and off.			
[ISR]	Recalls ISR radio station in memory. Press and hold for 2 seconds or longer: Stores current station into ISR memory (radio mode only). Press and hold the button for 1 second or longer to switch the main and sub zone sound source (only while 2-ZONE mode on).			
[DISP]	Switches among main display, clock display.			
[SCN]	Preset scan. When pressed and held for 2 seconds: Auto store.	Scan play. Press and hold the button for 1 second or longer to perform folder scan play while in the MP3/WMA mode.	Scan play. When pressed and held for 1 second: Disc scan play.	Preset scan. When pressed and held for 2 seconds: Auto store.
[RPT]	No function.	Repeat play. Press and hold the button for 1 second or longer to perform folder repeat play while in the MP3/WMA mode.	Repeat play. When pressed and held for 1 second: Disc repeat play.	No function.
[RDM]	No function.	Random play. Press and hold the button for 1 second or longer to perform folder random play while in the MP3/WMA mode.	Random play. When pressed and held for 1 second: Disc random play.	Switches between TV and VTR.
[2-ZONE]	Press and hold for 1 second or longer to turn on or off the 2-ZONE mode. Press to switch the control zone between main zone or sub zone while 2-ZONE mode on.			

* Some of the corresponding buttons on the main unit and remote control unit have different functions.

7. OPERATIONS

Basic Operations

Note: Be sure to read this chapter referring to the front diagrams of chapter "3. CONTROLS" on page 5 (unfold).

⚠ CAUTION

Be sure to lower the volume before switching off the unit power or the ignition key. The unit remembers its last volume setting. If you switch the power off with the volume up, when you switch the power back on, the sudden loud volume may hurt your hearing and damage the unit.

Turning on/off the power

Note:

• Be careful about using this unit for a long time without running the engine. If you drain the car's battery too far, you may not be able to start the engine and this can reduce the service life of the battery.

1. Press the [FNC] button.
2. The illumination and display on the unit light up. The unit automatically remembers its last operation mode and will automatically switch to display that mode.
3. Press and hold the [FNC] button for 1 second or longer to turn off the power for the unit.

Note:

• System check

The first time this unit is turned on after the wire connections are completed, it must be checked what equipment is connected. When the power is turned on, "SYSTEM CHCK" and "Push POWER" appear in the display alternately, so press the [FNC] button. The system check starts within the unit. When the system check is complete, press the [FNC] button again.

Selecting a mode

1. Press the [FNC] button to change the operation mode.
2. Each time you press the [FNC] button, the operation mode changes in the following order:

Radio mode → SIRIUS mode → CD/MP3/
WMA mode → CD changer mode → DVD
changer mode → TV mode → AUX mode →
Radio mode...

External equipment not connected with
CeNET is not displayed.

Adjusting the volume

1. Press the front part of the [ROTARY] knob. The knob will pop up.
2. Turning the [ROTARY] knob clockwise increases the volume; turning it counterclockwise decreases the volume.

The volume level is from 0 (minimum) to 33 (maximum).

Switching the display

Press the [D] button to select the desired display.

Each time you press the [D] button, the display switches in the following order:

Main display → Clock display → Main display

Once selected, the preferred display becomes the display default. When a function adjustment such as volume is made, the screen will momentarily switch to that function's display, then revert back to the preferred display several seconds after the adjustment.

When you have entered a title in a CD, it appears in the main display. If you have not entered a title, "NO-TITLE" appears in the title display instead. For information on how to enter a title, refer to the subsection "Entering titles" in section "Operations Common to Each Mode".

Setting the Anti Distortion Filter

The adopted "Liveliness Enhancement Filter" and "Sound Tone Compensation" functions allow well-modulated realistic playback without affecting the characteristics of the original sound tone.

This unit are provided with 3 types of sound tone effects stored in memory. Select the one you prefer.

The factory default setting is "ADF OFF".

Each time you press the [ADF] button, the tone effect changes in the following order:

"ADF-1" → "ADF-2" → "ADF-3" →
"ADF OFF" ...

- ADF-1 : suitable for the genuine speakers
- ADF-2 : suitable for separate speakers
- ADF-3 : suitable for coaxial speakers
- ADF OFF : no sound effect

Notes:

- The volume changes each time the ADF setting is switched. Turn down the volume and the subwoofer volume before performing a switching operation.
- Sufficient effects cannot be obtained with some speaker systems. In such cases, adjust the volume.

Adjusting the tone

Press the [A-M] button and select the item to adjust. Each time you press the [A-M] button, the item changes in the following order:

- **When the ADF-1 (ADF-2, ADF-3) is set**

“SUB-W VOL” → “BALANCE” →
“FADER” → Last function mode...

- **When the ADF-OFF is set**

“SUB-W VOL” → “BASS◀GAIN” →
“TREB◀GAIN” → “BALANCE” → “FADER”
→ Last function mode...

If subwoofer function is set “ON”, “SUB-W VOL” can be selected.

Adjusting the subwoofer output volume

You can adjust the volume output from the unit's subwoofer output terminal.

1. Press the [A-M] button and select “SUB-W VOL”.
2. Turning the [ROTARY] knob clockwise increases the output volume; turning it counterclockwise decreases the output volume.
The factory default setting is “0”. (Setting range: -6 to 6)
3. When the adjustment is complete, press the [A-M] button several times until the function mode is reached.

Adjusting the bass

The bass gain, bass FREQ (center frequency) and bass Q can be adjusted as follows.

1. Press the [A-M] button and select “BASS◀GAIN”.
2. Press the [◀] or [▶] button and select from “BASS◀GAIN” → “BASS◀FREQ” → “BASS◀Q” → “BASS◀GAIN”...
3. Turn the [ROTARY] knob clockwise or counterclockwise as needed and adjust the gain, the FREQ (center frequency) and the Q.

BASS GAIN : -6 to 8 (The factory default setting is “0”)

BASS FREQ : 50Hz/80Hz/120Hz (The factory default setting is “50”)

BASS Q : 1/1.25/1.5/2 (The factory default setting is “1”)

4. When the adjustment is complete, press the [A-M] button several times until the function mode is reached.

Adjusting the treble

The treble gain and treble FREQ (center frequency) can be adjusted as follows.

1. Press the [A-M] button and select “TREB◀GAIN”.
2. Press the [◀] or [▶] button and select from “TREB◀GAIN” → “TREB◀FREQ” → “TREB◀GAIN”...
3. Turn the [ROTARY] knob clockwise or counterclockwise as needed and adjust the gain and the FREQ (center frequency).
TREB GAIN : -6 to 6 (The factory default setting is “0”)
TREB FREQ : 8KHz/12KHz (The factory default setting is “12K”)
4. When the adjustment is complete, press the [A-M] button several times until the function mode is reached.

Adjusting the balance

1. Press the [A-M] button and select “BALANCE”.
2. Turning the [ROTARY] knob clockwise emphasizes the sound from the right speaker; turning it counterclockwise emphasizes the sound from the left speaker.
The factory default setting is “0”. (Adjustment range: L13 to R13)
3. When the adjustment is complete, press the [A-M] button several times until the function mode is reached.

Adjusting the fader

1. Press the [A-M] button and select “FADER”.
2. Turning the [ROTARY] knob clockwise emphasizes the sound from the front speakers; turning it counterclockwise emphasizes the sound from the rear speakers.

Basic Operations

The factory default setting is "0". (Adjustment range: F12 to R12)

- When the adjustment is complete, press the [A-M] button several times until the function mode is reached.

Adjusting MAGNA BASS EXTEND

The MAGNA BASS EXTEND does not adjust the low sound area like the normal sound adjustment function, but emphasizes the deep bass sound area to provide you with a dynamic sound.

The factory default setting is off.

- Press and hold the [A-M] button for 1 second or longer to turn on the MAGNA BASS EXTEND effect. "M-B EX" lights in the display.
- Press and hold the [A-M] button for 1 second or longer to turn off the MAGNA BASS EXTEND effect. "M-B EX" goes off from the display.

Radio Operations

FM reception

For enhanced FM performance the **MAGI-TUNECS**[®] tuner includes signal actuated stereo control, Enhanced Multi AGC, Impulse noise reduction circuits and Multipath noise reduction circuits.

Listening to the radio

- Press the [FNC] button and select the radio mode. The frequency in the display.
- Press the [BND] button and select the radio band. Each time the button is pressed, the radio reception band changes in the following order:
FM1 → FM2 → FM3 → AM → FM1...
- Press the [◀] or [▶] button to tune in the desired station.

Tuning

There are 3 types of tuning mode available, seek tuning, manual tuning and preset tuning.

Seek tuning

- Press the [BND] button and select the desired band (FM or AM).
If "MANU" is lit in the display, press and hold the [BND] button for 1 second or longer. "MANU" in the display goes off and seek tuning is now available.
- Press the [◀] or [▶] button to automatically seek a station.
When the [▶] button is pressed, the station is sought in the direction of higher frequencies; if the [◀] button is pressed, the station is sought in the direction of lower frequencies.

Manual tuning

There are 2 ways available: Quick tuning and step tuning.

When you are in the step tuning mode, the frequency changes one step at a time. In the quick tuning mode, you can quickly tune the desired frequency.

- Press the [BND] button and select the desired band (FM or AM).
If "MANU" is not lit in the display, press and hold the [BND] button for 1 second or longer. "MANU" is lit in the display and manual tuning is now available.

2. Tune into a station.

● **Quick tuning:**

Press and hold the [◀◀] or [▶▶] button for 1 second or longer to tune in a station.

● **Step tuning:**

Press the [◀] or [▶] button to manually tune in a station.

Recalling a preset station

A total of 24 preset positions (6-FM1, 6-FM2, 6-FM3, 6-AM) exists to store individual radio stations in memory. Pressing the corresponding [DIRECT] button recalls the stored radio frequency automatically.

1. Press the [BND] button and select the desired band (FM or AM).
2. Press the corresponding [DIRECT] button to recall the stored station.

Press and hold one of the [DIRECT] buttons for 2 seconds or longer to store that station into preset memory.

Manual memory

1. Select the desired station with seek tuning, manual tuning or preset tuning.
2. Press and hold one of the [DIRECT] buttons for 2 seconds or longer to store the current station into preset memory.

Auto store

Auto store is a function for storing up to 6 stations that are automatically tuned in sequentially. If 6 receivable stations cannot be received, a previously stored station remains unoverwritten at the memory position.

1. Press the [BND] button and select the desired band (FM or AM).
2. Press and hold the [P/A] button for 2 seconds or longer. The stations with good reception are stored automatically to the preset channels.

If auto store is performed in the FM bands, the stations are stored in FM3 even if FM1 or FM2 was chosen for storing stations.

Preset scan

Preset scan receives the stations stored in preset memory in order. This function is useful when searching for a desired station in memory.

1. Press the [P/A] button.
2. When a desired station is tuned in, press the [P/A] button again to continue receiving that station.

Note:

- Be careful not to press and hold the [P/A] button for 2 seconds or longer, otherwise the auto store function is engaged and the unit starts storing stations.

Instant station recall (ISR)

Instant station recall is a special radio preset that instantly accesses a favorite radio station at a touch of a button. The ISR function even operates with the unit in other modes.

● **ISR memory**

1. Select the station that you wish to store in ISR memory.
2. Press and hold the [ISR] button for 2 seconds or longer.

● **Recalling a station with ISR**

In any mode, press the [ISR] button to turn on the radio function and tune the selected radio station. "ISR" appears in the display. Press the [ISR] button again to return to the previous mode.

CD/MP3/WMA Operations

MP3/WMA

What is MP3?

MP3 is an audio compression method and classified into audio layer 3 of MPEG standards.

This audio compression method has penetrated into PC users and become a standard format.

This MP3 features the original audio data compression to about 10 percent of its initial size with a high sound quality. This means that about 10 music CDs can be recorded on a CD-R disc or CD-RW disc to allow a long listening time without having to change CDs.

What is WMA?

WMA is the abbreviation of Windows Media Audio, an audio file format developed by Microsoft Corporation.

Notes:

- If you play a file with DRM (Digital Rights Management) for WMA remaining ON, no audio is output (The WMA indicator blinks).
- Windows Media™, and the Windows ® logo are trademarks, or registered trademarks of Microsoft Corporation in the United States and/or other countries.

● To disable DRM (Digital Rights Management):

1. When using Windows Media Player 8, click on TOOLS → OPTIONS → COPY MUSIC tab, then under COPY SETTINGS, unclick the check box for PROTECT CONTENT. Then, reconstruct files.
2. When using Windows Media Player 9, click on TOOL → OPTIONS → MUSIC RECORD tab, then under Recording settings, unclick the Check box for RECORD PROTECTED MUSIC. Then, reconstruct files.

Personally constructed WMA files are used at your own responsibility.

Precautions when creating MP3/WMA disc

● Usable sampling rates and bit rates:

1. MP3: Sampling rate 11.025 kHz-48 kHz,
Bit rate: 8 kbps-320 kbps / VBR
2. WMA: Bit rate 48 kbps-192 kbps

● File extensions

1. Always add a file extension “.MP3” or “.WMA” to MP3 or WMA file by using single byte letters. If you add a file extension other than specified or forget to add the file extension, the file cannot be played.

2. Files without MP3/WMA data will not play. The indication “--:--” appears in the play time display if you attempt to play files without MP3/WMA data.

● Logical format (File system)

1. When writing MP3/WMA file on a CD-R disc or CD-RW disc, please select “ISO9660 level 1, 2 or JOLIET or Romeo” as the writing software format. Normal play may not be possible if the disc is recorded on another format.
2. The folder name and file name can be displayed as the title during MP3/WMA play but the title must be within 128 single byte alphabetical letters and numerals (including an extension).
3. Do not affix a name to a file inside a folder having the same name.

● Folder structure

1. A disc with a folder having more than 8 hierarchical levels will be impossible.

● Number of files or folders

1. Up to 255 files can be recognized per folder. Up to 500 files can be played.
2. Tracks are played in the order that they were recorded onto a disc. (Tracks might not always be played in the order displayed on the PC.)
3. Some noise may occur depending on the type of encoder software used while recording.

Multisession function

When a disc contains both normal CD type tracks and MP3/WMA type tracks mixedly, you can select which type of the recorded tracks to play.

● Default value is “CD”.

Each time you press and hold the [BND] button for 1 second or longer, the mixed mode is switched between CD type or MP3/WMA type. The following indication appears in the title display when switching the track type to be played.

● Display when CD type track is selected:

M-SESS CD



● Display when MP3/WMA type track is selected:

M-SESS MP3

1. Types of recording that can be played are as follows.

Disc \ Setting	Set to CD	Set to MP3/WMA
Mixed with CD and MP3/WMA type tracks	Play CD	Play MP3/WMA
CD type track only	Play CD	Play CD
MP3/WMA type track only	Play MP3/WMA	Play MP3/WMA

- After making these settings, remove the disc and then reinsert it.
- When a mixed mode CD is loaded and CD is set, the track to be played first is MP3/WMA file data and no sound is heard.

Note:

- When playing a CCCD (Copy Control CD), set the setting to CD type. When this is set to MP3/WMA type, the CD cannot be played normally in some cases.

Disc-In-Play function

As long as the ignition key is turned to the ON or ACC position, this function allows you to turn the power to the unit and start playing the disc automatically when the disc is inserted even if the power is not turned on.

CAUTION

- Do not try to put your hand or fingers in the disc insertion slot. Also never insert foreign objects into the slot.
- Do not insert discs where adhesive comes out from cellophane tape or a rental CD label, or discs with marks where cellophane tape or rental CD labels were removed. It may be impossible to extract these discs from the unit and they may cause the unit to break down.

Backup Eject function

Just pressing the [▲] button ejects the disc even if the power to the unit was not turned on.

- Press the [▲] button. The MOTORIZED FACE opens and a CD ejects. "EJECT" appears in the display.

CAUTION

Be careful not to get your fingers caught when opening and closing the MOTORIZED FACE.

- Remove the CD and press the [▲] button to close the MOTORIZED FACE.

Notes:

- Be sure to close the MOTORIZED FACE after removing the CD.
- The MOTORIZED FACE closes automatically 30 seconds after removing the CD.
- If a CD (12 cm) is left in the ejected position for 15 seconds, the CD is automatically reloaded. (Auto reload)
- 8 cm CDs are not auto reloaded. Be sure to remove it when ejected.
- If you force a CD into before auto reloading, this can damage the CD.

Listening to a disc already loaded in the unit

Press the [FNC] button to select the CD/MP3/WMA mode.

When the unit enters the CD/MP3/WMA mode, play starts automatically.

If there is no disc loaded, the indication "NO DISC" appears in the title display.

The mode changes each time the [FNC] button is pressed. (Modes are not displayed for equipment that is not connected.)

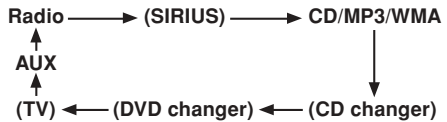

Loading a CD

- Press the [▲] button. The MOTORIZED FACE opens.

CAUTION

Be careful not to get your fingers caught when opening and closing the MOTORIZED FACE.

- Insert a CD into the center of the insertion slot with the labeled side facing up. The CD plays automatically after loading.

Notes:

- Never insert foreign objects into the CD insertion slot.
- If the CD is not inserted easily, there may be another CD in the mechanism or the unit may require service.
- Discs not bearing the COMPACT DISC DIGITAL AUDIO or REMASTERED DIGITAL AUDIO mark and CD-ROMs cannot be played by this unit.
- Some CDs recorded in CD-R/CD-RW mode may not be usable.

CD/MP3/WMA Operations

Loading 8 cm compact discs

No adapter is required to play an 8 cm CD.

Insert the 8 cm CD into the center of the insertion slot.

- After loading a CD, the MOTORIZED FACE closes automatically.

Notes:

- Note that MOTORIZED FACE closes immediately after a CD is inserted into CD insertion slot.
- If no CD is loaded in the MOTORIZED FACE, it closes after 30 seconds.

Pausing play

- Press the [▶||] button to pause play. "PAUSE" appears in the display.
- To resume CD play, press the [▶||] button again.

Displaying CD titles

This unit can display title data for CD-text/MP3/WMA disc and user titles input with this unit.

- Press the [D] button to display the title.
- Each time you press and hold the [D] button for 1 second or longer, the title display changes in the following order:

● CD-TEXT disc

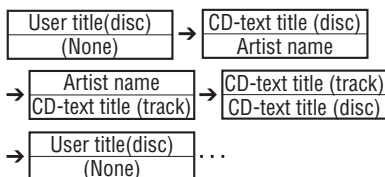

● MP3/WMA disc

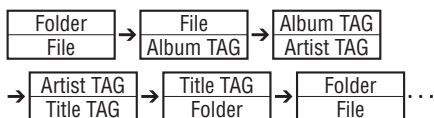

Notes:

- If the CD playing is not a CD-text CD or no user title has been input, "NO-TITLE" appears in the display.
- If MP3/WMA disc is not input TAG, "NO-TAG" appears in the display.
- For MP3, supports ID3 Tags V2.3 / 2.2 / 1.1 / 1.0.
- Tag displays give priority to V2.3 / 2.2
- In the case of album Tags for WMA, the information written into the extension header is displayed.
- Only ASCII characters can be displayed in Tags.

Selecting a track

● Track-up

- Press the [▶▶] button to move ahead to the beginning of the next track.
- Each time you press the [▶▶] button, the track advances ahead to the beginning of the next track.

● Track-down

- Press the [◀◀] button to move back to the beginning of the current track.
- Press the [◀◀] button twice to move to the beginning of the previous track.

Fast-forward/fast-backward

● Fast-forward

Press and hold the [▶▶] button for 1 second or longer.

● Fast-backward

Press and hold the [◀◀] button for 1 second or longer.

For MP3/WMA discs, it takes some time until the start of searching and between tracks. In addition, the playing time may have a margin of error.

Folder select

This function allows you to select a folder containing MP3/WMA files and start playing from the first track in the folder.

- Press the [DN] or the [UP] button.

Press the [DN] button to move the previous folder.

Press the [UP] button to move the next folder.

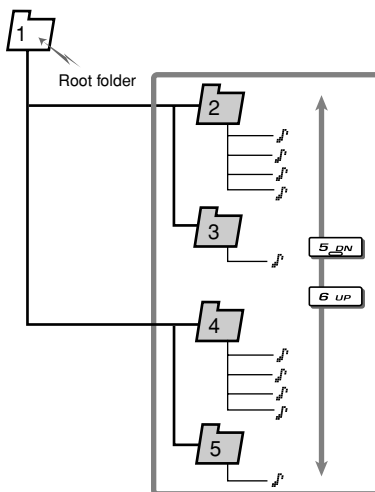

Press the [UP] button while in the final folder to shift to the first folder.

Folder without an MP3/WMA file is not selectable.

- To select a track, press the [◀] or [▶] button.

Top function

The top function resets the CD player to the first track of the disc. Press the [BND] button to play the first track (track No. 1) on the disc.

In case of MP3/WMA, the first track of a folder being played will be returned.

Scan play

This function allows you to locate and play the first 10 seconds of all the tracks recorded on a disc.

- Press the [SCN] button to perform scan play.

The indication "SCN" lights up in the display, and "TRK SCAN" (or "J-SCAN" when searching for a track in the MP3/WMA file) appears in the title display for about 2 seconds, then scan play starts.

Scan play starts from the next track after the track currently being played.

- To cancel scan play, press the [SCN] button again.

The play status indication such as "SCN" disappears from the display and the current track is played.

Folder scan play

This function allows you to locate and play the first 10 seconds of the first track of all the folders on an MP3/WMA disc.

- Press and hold the [SCN] button for 1 second or longer to perform to folder scan play.

The indications "FOLDER" and "SCN" light up in the display and "FOLDER-SCAN" appears for about 2 seconds in the title display, and then folder scan play starts.

Folder scan play starts from the next track after the track currently being played.

- To cancel folder scan play, press the [SCN] button again.

The play status indications such as "FOLDER" and "SCN" disappear from the display and the current track is played.

Repeat play

This function allows you to play the current track repeatedly.

- Press the [RPT] button to perform repeat play.

The indication "RPT" lights up in the display and "TRK REPEAT" (or "J-REPEAT" when performing repeated play for a track in the MP3/WMA file) appears for about 2 seconds in the title display, and then repeat play starts.

- To cancel repeat play, press the [RPT] button again.

The play status display such as "RPT" disappears from the display and normal play resumes from the track currently being played.

Folder repeat play

This function allows you to play a track currently being played in the MP3/WMA folder repeatedly.

- Press and hold the [RPT] button for 1 second or longer to perform folder repeat play.

The indications "FOLDER" and "RPT" light up in the display and "FOLDER-REPEAT" appears for about 2 seconds in the title display, and then folder repeat play starts.

- To cancel folder repeat play, press the [RPT] button again.

The play status indications such as "FOLDER" and "RPT" disappear from the display and normal play resumes from the track currently being played.

Random play

This function allows you to play all tracks recorded on a disc in a random order.

- Press the [RDM] button to perform random play.

The indication "RDM" lights up in the display and "TRK RANDOM" (or "J-RANDOM" when performing random play for tracks on a MP3/WMA disc) appears in the title display for about 2 seconds, and then random play starts. The tracks on the disc are then played in a random order.

- To cancel random play, press the [RDM] button again.

The play status indication such as "RDM" disappears from the display and normal play resumes from the track currently being played.

CD/MP3/WMA Operations

Folder random play

This function allows you to play all the tracks of all the folders recorded on an MP3/WMA disc in a random order.

1. Press and hold the **[RDM]** button for 1 second or longer to perform folder random play. The indications "**FOLDER**" and "**RDM**" light up in the display and "**■-RANDOM**" appear in the title display for about 2 seconds, and then folder random play starts.
2. To cancel folder random play, press the **[RDM]** button again. The play status indications such as "**FOLDER**" and "**RDM**" disappear from the display and normal play resumes from the track currently being played.

Play list mode

This function allows you to play tracks, up to latest 5 time stamps, by reading the play list information written on the disc.

1. Press and hold the **[PLAY LIST]** button for 1 second or longer to turn on or off the play list mode.

Play list play is possible only when there is a file whose extension is "**.M3U**" on the CD-R/RW.

Up to 5 play lists can be recognized, and up to 255 files can be recognized per play list.
2. Press the **[◀]** or **[▶]** button to change the track.
3. Press the **[DN]** button to move to the previous play list.

Press the **[UP]** button to move to the next play list.

Notes:

- The **SCN/RPT/RDM** functions cannot be used while in the play list mode.
- The title display changes from folder name to play list name.

Making a play list

1. Write desired tracks to a CD-R/RW, etc. Be sure to use alphanumeric/ASCII characters for all file names.
2. Make a play list by using a multimedia player, etc. and save the data. The file format must be M3U.
3. Again, write this play list to the CD-R/RW, etc.

Notes:

- When writing to a CD-R/RW, etc., be sure to use alphanumeric/ASCII characters.
- Up to 5 layers can be recognized as a list. For written play lists, latest 5 lists are recognized in the order in which they are written.
- When writing to a CD-R/RW, etc., turn off the Disc At Once function.
- When adding a play list, it is recommended to write it in the "**Root**" folder.

Different pieces of music heard by plural listeners (2-ZONE function)

About the 2-ZONE function

The 2-ZONE function is a function that outputs separate sounds from the MAIN zone and SUB zone by simultaneously operating two sources in the one center unit, thereby allowing plural listeners to enjoy separate music sources.

This unit can control its internal sources (radio, CD, MP3, etc.) to play back them, and further, can simultaneously play back sources from external equipment connected via CeNET (for instance, CD changers etc.).

The sources of the MAIN zone are played back from the speakers of the vehicle side, and those of the SUB zone are from the headphone systems (WH104/WH204).

Notes:

- Except AUX, the MAIN and SUB zones cannot simultaneously use sources inside this unit. Also, external equipment connected via CeNET cannot simultaneously be used.
- The TV mode while the 2-ZONE function is tuned on is forced to change to "VTR playback."
- The ISR function cannot be operated when the 2-ZONE function is turned on.
- The Audio mode and ADF function cannot be set for the sources of the SUB zone.
- If any of following external equipment is connected, this function is disabled.
 - 5.1 channel surround decoder (DVH920/DVH940)

Setting the 2-ZONE function

The initial setting is "OFF".

When you have set the 2-ZONE function to "ON" in the initial state, the MAIN zone services for sources inside this unit and the SUB zone, for AUX. Changing a source during later use causes the latest heard source to be invoked.

Press and hold the [] button for 1 second or longer to turn on or off. When the 2-ZONE function is turned on, "2-ZONE ON" on the display lights.

Switching sources

1. Press the [] button to select the control zone ("MAIN" or "SUB").
Every time the button is pressed, the "MAIN ZONE" changes to the "SUB ZONE" or vice versa.
"MAIN" or "SUB" on the display lights at that time, thereby indicating that the relevant zone becomes ready to operate.

2. Press the [FNC] button to select a source in the control zone.
Every time the button is pressed, the followings appear in turn.

● For a source group included in this unit:

Radio → CD/MP3 → AUX → Radio...

● For a source group in external equipment:

AUX → CD changer → DVD changer → TV → AUX...

The name of equipment that is not connected to this unit is not displayed.

- To change a current musical performance etc., press the button that controls the selected source ([SCN] button, etc.).

● Example for source change

Operation	MAIN zone	SUB zone
2-ZONE turned off	Radio playback ↓	Radio playback ↓
2-ZONE turned on	Radio playback ↓	AUX ↓
2-ZONE turned off	Radio playback ↓	Radio playback ↓
Source change	External equipment (CD changer) ↓	External equipment (CD changer) ↓
2-ZONE turned on	External equipment (CD changer)	Radio playback

Adjusting the sound level for the MAIN zone

You can adjust the sound level only for the MAIN zone. To adjust the sound level for the SUB zone, adjust it in the headphone (WH104/WH204) side. Turning the [ROTARY] knob to adjust the sound level for the MAIN zone.

Counterchanging the sources of the MAIN and SUB zones

You can supersede the music sources of the MAIN and SUB zones.

Press and hold the [ISR] button for 1 second or longer to counterchange the sources of the MAIN and SUB zones.

"REVERSE" is displayed for 2 seconds on the display.

Operations Common to Each Mode

Turning the screen saver function on or off

This unit is provided with the screen saver function which allows you to show various kinds of patterns and characters in the Operation Status indication area of the display in a random order. You can turn on and off this function.

If the button operation is performed with the screen saver function on, the operation display corresponding to the button operation is shown for about 30 seconds and the display returns to the screen saver display.

The factory default setting is "RANDOM".

1. Press and hold the [T] button for 1 second or longer to switch to the adjustment selection display.
2. Press the [◀] or [▶] button to select "◀SCRN SVR ▶
PUSH ENT".
3. Press the [▶||] button.
4. Turn the [ROTARY] knob clockwise or counterclockwise to select the setting. Each time you turn the [ROTARY] knob, the setting changes in the following order:
"◀ OFF" → "◀Pattern-1▶" →
"◀Pattern-2▶" → "◀Pattern-3▶" →
"◀ MESSAGE▶" → "◀ RANDOM▶"
5. Press the [T] button to return to the previous mode.

Entering MESSAGE INFORMATION

Message up to 30 characters long can be stored in memory and displayed for CD, CD changer and TV stations.

The factory default setting is "Welcome to Clarion".

1. Press and hold the [T] button for 1 second or longer to switch to the adjustment selection display.
2. Press the [◀] or [▶] button to select "◀MSG INPUT▶
PUSH ENT".
3. Press the [▶||] button.
4. Press the [BND] button to clear the old message.
5. Press the [◀] or [▶] button to move the cursor.
6. Press the [D] button to select a character. Each time you press the [D] button, the character changes in the following orders:
Capital letters → Small letters → Numbers/
Symbols → Umlaut → Capital letters...

7. Turn the [ROTARY] knob clockwise or counterclockwise to select the desired character.
8. Repeat step 5 to 7 to enter up to 30 characters for message.
9. Press and hold the [▶||] button for 2 seconds or longer to store the message in memory and cancel input message.
10. Press the [T] button to return to the previous mode.

Message display

When the unit is powered on or off, a message is displayed. The user can turn this message display ON or OFF.

The factory default setting is "ON".

1. Press and hold the [T] button for 1 second or longer to switch to the adjustment selection display.
2. Press the [◀] or [▶] button to select "◀MESSAGE ▶".
3. Turn the [ROTARY] knob clockwise or counterclockwise to set the message display "ON" or "OFF".
4. Press the [T] button to return to the previous mode.

Setting the method for title scroll

Set how to scroll in CD-TEXT or MP3/WMA.

The factory default setting is "ON".

1. Press and hold the [T] button for 1 second or longer to switch to the adjustment selection display.
2. Press the [◀] or [▶] button to select "◀AUTO SCRL▶".
3. Turn the [ROTARY] knob clockwise or counterclockwise and select "ON" or "OFF".
 - ON:
To scroll automatically.
 - OFF:
To scroll just 1 time when the title was changed or the title key was pressed.
4. Press the [T] button to return to the previous mode.

Dimmer level

You can adjust the reduced illumination level of the dimmer.

The factory default setting is "LV3".
(Adjustment range is LV1 to LV5)

1. Press and hold the [T] button for 1 second or longer to switch to the adjustment selection display.
2. Press the [◀] or [▶] button to select the "◀DIMMER LV▶".
3. Turn the [ROTARY] knob clockwise or counterclockwise to adjust the reduced illumination level of the dimmer.

● **LV1 to LV5:**

The dimmer operation is performed depending on the set level LV1 to LV5.

● **OFF:**

No dimmer operation is performed.

4. Press the [T] button to return to the previous mode.

Adjusting the display contrast

You can adjust the display contrast to match the angle of installation of the unit.

The factory default setting is "8". (Adjustment level: 1 to 18)

1. Press and hold the [T] button for 1 second or longer to switch to the adjustment selection display.
2. Press the [◀] or [▶] button to select "◀CONTRAST ▶".
3. Turn the [ROTARY] knob clockwise or counterclockwise to adjust the contrast.
4. Press the [T] button to return to the previous mode.

Anti-theft indicator

The red Anti-theft indicator is a function for preventing theft. When the DCP is removed from the unit, this indicator blinks.

The factory default setting is "OFF".

1. Press and hold the [T] button for 1 second or longer to switch to the adjustment selection display.
2. Press the [◀] or [▶] button and select "◀BLINK LED▶".
3. Turn the [ROTARY] knob clockwise to set this function "ON" or turn it counterclockwise to switch this function "OFF".
4. Press the [T] button to return to the previous mode.

Setting the Subwoofer

You can set the subwoofer on or off.

The factory default setting is "ON".

1. Press and hold the [T] button for 1 second or longer to switch to the adjustment selection display.
2. Press the [◀] or [▶] button and select "◀ SUB-W ▶".
3. Turn the [ROTARY] knob clockwise or counterclockwise and select "ON" or "OFF".
4. Press the [T] button to return to the previous mode.

Setting LOW PASS FILTER

The factory default setting is "THRGH". (Through). If subwoofer function is set "ON", "LOW PASS FILTER" can be selected.

1. Press and hold the [T] button for 1 second or longer to switch to the adjustment selection display.
2. Press the [◀] or [▶] button and select "◀SUB-W LPP▶".
3. Turn the [ROTARY] knob clockwise or counterclockwise to select the setting. Each time you turn the [ROTARY] knob, the setting changes in the following order:
THRGH → 50Hz → 80Hz → 120Hz
4. Press the [T] button to return to the previous mode.

Setting the external amplifier

The factory default setting is "OFF".

1. Press and hold the [T] button for 1 second or longer to switch to the adjustment selection display.
2. Press the [◀] or [▶] button and select "◀AMP-CANCL▶".
3. Turn the [ROTARY] knob clockwise or counterclockwise and select "ON" or "OFF".
● **ON:**
Use with connected AMP.
● **OFF:**
Use with inside AMP.
4. Press the [T] button to return to the previous mode.

Operations Common to Each Mode

AUX function

This system has an external input jack so you can listen to sounds and music from external devices connected to this unit.

Selecting AUX IN sensitivity

Make the following settings to select the sensitivity when sounds from external devices connected to this unit are difficult to hear even after adjusting the volume.

The factory default setting is "MID".

1. Press and hold the [T] button for 1 second or longer to switch to the adjustment selection display.
2. Press the [◀] or [▶] button to select "◀AUX SENS ▶".
3. Turn the [ROTARY] knob clockwise or counterclockwise as needed and select from "HIGH", "MID" or "LOW".
4. Press the [T] button to return to the previous mode.

Triggered audio mute for cellular telephones

This unit requires special wiring to mute the audio signal automatically when a cellular telephone rings in the car.

This function is not compatible with all cellular telephones. Contact your local authorized Clarion dealer for information on proper installation and compatibility.

Setting the clock

1. Press and hold the [T] button for 1 second or longer to switch to the adjustment selection display.
2. Press the [◀] or [▶] button to select "◀CLOCK▶
PUSH ENT".
3. Press the [▶||] button.
4. Press the [◀] or [▶] button to select the hour or the minute.
5. Turn the [ROTARY] knob clockwise or counterclockwise to set the correct time.
The clock is displayed in 12-hour format.
6. Press the [▶||] button to store the time into memory.
7. Press the [T] button to return to the previous mode.

Note:

- You cannot set the clock when it is displayed with only the ignition on. If you drain or remove the car's battery or take out this unit, the clock is reset. While setting the clock, if another button or operation is selected, the clock set mode is canceled.

Setting the button illumination

Press the [COLOR] button to select a color type. Each time you press the [COLOR] button, the type changes in the following orders:

COLOR SCAN → Indigo Blue → Surf Blue → Silky White → Aqua Green → Fresh Green → Leaf Green → Warm Amber → Passion Red → Vivid Pink → Pale Pink → Dark Violet → Pure Purple → USER COLOR 1 → USER COLOR 2 → USER COLOR 3 → COLOR SCAN ...

●Setting COLOR SCAN mode

As selecting "COLOR SCAN", the color automatically changes.

The factory default setting is "COLOR SCAN".

After 3 seconds the color changes to the other.

●Setting USER mode

The factory default setting is "R>8 G>8 B>8" (R:red, G:green, B:blue).

As selecting "USER COLOR 1, 2, 3", press and hold the [COLOR] button for 1 second or longer "R>8 G>8 B>8" appears in the display.

1. Press the [◀] or [▶] button to move the cursor.
2. Turn the [ROTARY] knob to select from 0 to 8.
3. Press and hold the [▶||] button for 2 seconds or longer to store the color in memory and cancel setting mode.

COLOR	R	G	B
Indigo Blue	0	1	8
Surf Blue	0	4	8
Silky White	6	8	8
Aqua Green	0	8	2
Fresh Green	0	8	0
Leaf Green	4	8	0
Warm Amber	8	3	0
Passion Red	8	0	0
Vivid Pink	8	0	3
Pale Pink	8	1	3
Dark Violet	3	0	8
Pure Purple	8	0	8
USER COLOR 1	8	8	8
USER COLOR 2	8	8	8
USER COLOR 3	8	8	8

Entering titles

Titles up to 10 characters long can be stored in memory and displayed for Radio, CD, CD changer, tuner station and TV stations. The number of titles that can be entered for each mode are as follows.

Mode	Number of titles
CD mode	50 titles
TV mode	20 titles
TUNER mode	30 titles

CD changer mode	Number of titles
DCZ625 connected	100 titles
CDC655Tz connected	100 titles
CDC1255z connected	50 titles

1. Press the **[FNC]** button to select the mode you want to enter a title (tuner, CD, CD changer or TV).
2. Select and play a CD in the CD changer or tune in to a TV station for which you want to enter the title.
3. Press the **[D]** button and display the main.
4. Press the **[T]** button.
5. Press the **[◀◀]** or **[▶▶]** button to move the cursor.
6. Press the **[D]** button to select a character. Each time you press the **[D]** button, the character changes in the following order:
Capital letters → Small letters → Numbers/Symbols → Umlaut → Capital letters...
7. Turn the **[ROTARY]** knob to select the desired character.
8. Repeat steps 5 to 7 to enter up to 8 characters for the title.
9. Press and hold the **[▶▶▶▶]** button for 2 seconds or longer to store the title into memory and cancel title input mode.

Clearing titles

1. Select and play a CD in the CD changer or tune in to a TV station for which you want to clear the title.
2. Press the **[D]** button and display the main.
3. Press the **[T]** button.
The display switches to the title input display.
4. Press the **[BND]** button.
5. Press and hold the **[▶▶▶▶]** button for 2 seconds or longer to clear the title and cancel title input mode.

8. OPERATIONS OF ACCESSORIES

CD Changer Operations

CD changer functions

When an optional CD changer is connected through the CeNET cable, this unit controls all CD changer functions. This unit can control a total of 2 changers.

Press the **[FNC]** button and select the CD changer mode to start play. If 2 CD changers are connected, press the **[FNC]** button to select the CD changer for play.

If **"NO MAGAZINE"** appears in the display, insert the magazine into the CD changer. **"DISC CHECK"** appears in the display while the player loads (checks) the magazine.

If **"NO DISC"** appears in the display, eject the magazine and insert discs into each slot. Then, reinsert the magazine back into the CD changer.

Note:

- Some CDs recorded in CD-R/CD-RW mode may not be usable.

CAUTION

CD-ROM discs cannot be played from every CD changer, it's depended on the model.

Pausing play

1. Press the **[▶||]** button to pause play. **"PAUSE"** appears in the display.
2. To resume play, press the **[▶||]** button again.

Displaying CD titles

This unit can display title data for CD-text CDs and user titles input with this unit.

Title data for CD-text CDs can be displayed with this unit only when it is connected to CDC655Tz.

● When connected to DCZ625 or CDC1255z.

Press the **[D]** button to display the title.

● When connected to CDC655Tz

1. Press the **[D]** button to display the title.
2. Each time you press and hold the **[D]** button for 1 second or longer, the title display changes in the following order:

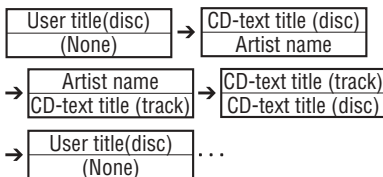

Notes:

- If the CD playing is not a CD-text CD or no user title has been input, **"NO-TITLE"** appears in the display.
- If a CD-text CD is not input its disc title or a track title, **"NO-TITLE"** appears in the display.

Procedure to scroll a title

Set **"AUTO SCROLL"** to **"ON"** or **"OFF"**.

(The factory default setting is **"ON"**. Refer to the subsection **"Turning the screen saver function on or off"** in section **"Operation Common to Each Mode"**.)

● When set to **"ON"**

The title is automatically kept scrolling.

● When set to **"OFF"**

To scroll just 1 time when the title was changed or the **[T]** button was pressed.

Selecting a CD

Press the **[DN]** or the **[UP]** button to select the desired disc.

If a CD is not loaded in a slot of magazine, pressing the **[UP]** or the **[DN]** button cannot work.

Selecting a track

● Track-up

1. Press the **[▶▶]** button to move ahead to the beginning of the next track.
2. Each time you press the **[▶▶]** button, the track advances ahead to the beginning of the next track.

● Track-down

1. Press the **[◀◀]** button to move back to the beginning of the current track.
2. Press the **[◀◀]** button twice to move to the beginning of the previous track.

Fast-forward/fast-backward

● Fast-forward

Press and hold the [▶▶] button for 1 second or longer.

● Fast-backward

Press and hold the [◀◀] button for 1 second or longer.

Scan play

Scan play locates and plays the first 10 seconds of each track on a disc automatically. This function continues on the disc until it is cancelled.

The scan play is useful when you want to select a desired track.

1. Press the [SCN] button to start track scanning. "SCN" lights in the display.
2. To cancel the scan play, press the [SCN] button again. "SCN" goes off from the display and the current track continues to play.

Disc scan play

Disc scan play locates and plays the first 10 seconds of the first track on each disc in the currently selected CD changer. This function continues automatically until it is cancelled.

Disc scan play is useful when you want to select a desired CD.

1. Press and hold the [SCN] button for 1 second or longer. "DISC" and "SCN" light in the display and disc scan play starts.
2. To cancel disc scan play, press the [SCN] button again. "DISC" and "SCN" go off from the display and the current track continues to play.

Repeat play

Repeat play continuously plays the current track. This function continues automatically until it is cancelled.

1. Press the [RPT] button. "RPT" lights in the display and the current track is repeated.
2. To cancel repeat play, press the [RPT] button again. "RPT" goes off from the display and normal play resumes.

Disc repeat play

After all the tracks on the current disc have been played, disc repeat play automatically replays the current disc over from the first track. This function continues automatically until it is cancelled.

1. Press and hold the [RPT] button for 1 second or longer. "DISC" and "RPT" light in the display and disc repeat play starts.
2. To cancel disc repeat play, press the [RPT] button again. "DISC" and "RPT" go off from the display and normal play resumes on the current track.

Random play

Random play selects and plays individual tracks on the disc in no particular order. This function continues automatically until it is cancelled.

1. Press the [RDM] button. "RDM" lights in the display and random play begins.
2. To cancel random play, press the [RDM] button again. "RDM" goes off from the display and normal play resumes.

Disc random play

The disc random play selects and plays individual tracks or discs automatically in no particular order. This function continues automatically until it is cancelled.

1. Press and hold the [RDM] button for 1 second or longer. "DISC" and "RDM" light in the display and disc random play starts.
2. To cancel disc random play, press the [RDM] button again. "DISC" and "RDM" go off from the display and normal play resumes from the current track.

TV Operations

TV tuner functions

When an optional TV tuner is connected through the CeNET cable, this unit controls all TV tuner functions. To watch TV requires a TV tuner and monitor.

Watching a TV

1. Press the **[FNC]** button and select the TV mode.
2. Press the **[BND]** button to select the desired TV band (TV1 or TV2). Each time the button is pressed, the input selection toggles between TV1 and TV2.
3. Press the **[◀]** or **[▶]** button to tune in the desired TV station.

Watching a video

The TV tuner has a VTR input terminal to which 1 external device can be connected. Connect a 12 V video cassette player (VCP) or video cassette recorder (VCR) to the TV tuner input terminal.

1. Press the **[▶||]** button to select VTR.
2. To return to the TV broadcast, press the **[▶||]** button.

Tuning

There are 3 types of tuning mode available, Seek tuning, manual tuning and preset tuning.

Seek tuning

1. Press the **[BND]** button and select the desired TV band (TV1 or TV2).
If "MANU" is lit in the display, press and hold the **[BND]** button for 1 second or longer. "MANU" in the display goes off and seek tuning is now available.
2. Press the **[◀]** or **[▶]** button to automatically seek a station. Press the **[▶]** button to automatically tune up the frequency band to the next available TV station; press the **[◀]** button to automatically tune down.

Manual tuning

There are 2 ways available: Quick tuning and step tuning.

When you are in the step tuning mode, the frequency changes one step at a time. In the quick tuning mode, you can quickly tune the desired frequency.

1. Press the **[BND]** button and select the desired band (TV1 or TV2).

If "MANU" is not lit in the display, press and hold the **[BND]** button for 1 second or longer. "MANU" lights in the display and manual tuning is now available.

2. Tune into a station.

● Quick tuning:

Press and hold the **[◀]** or **[▶]** button for 1 second or longer to tune in a station.

● Step tuning:

Press the **[◀]** or **[▶]** button to manually tune in a station.

Recalling a preset station

A total of 12 TV stations can be stored (6-TV1 and 6-TV2). This allows you to select your favorite TV stations and store them in memory for later recall.

1. Press the **[BND]** button and select the desired TV band (TV1 or TV2).
2. To recall a stored TV station, press the desired **[DIRECT]** button to select that station.

Press and hold one of the **[DIRECT]** buttons for 2 seconds or longer to store the current station into preset memory.

Manual memory

1. Select the desired station with seek tuning, manual tuning or preset tuning.
2. Press and hold one of **[DIRECT]** buttons for 2 seconds or longer to store the current station into preset memory.

Auto store

Auto store selects 6 TV stations automatically and stores each one into preset memory.

If there are not 6 stations with good reception, stations previously stored in memory remain and only the strong stations are stored into memory.

1. Press the **[BND]** button and select the desired TV band (TV1 or TV2).
2. Press and hold the **[P/A]** button for 2 seconds or longer. The stations with good reception are stored automatically to the preset channels.

Preset scan

Preset scan allows the user to view each preset position before it automatically advances to the next preset. This function is useful for searching for a desired TV station in memory.

1. Press the **[P/A]** button.
2. When the desired station is found, press the **[P/A]** button again to remain tuned to that station.

Note:

- Do not press and hold the **[P/A]** button for 2 seconds or longer. Doing so will trigger the auto store function and start storing stations into memory.

Setting the TV diver

You can change the reception setting for the TV antenna connected to the TV tuner.

1. Press and hold the **[T]** button for 1 second or longer to switch to the adjustment selection display.
2. Press the **[◀]** or **[▶]** button to select “**TV DIVER**”.
3. Turn the **[ROTARY]** knob clockwise to set to “**ON**” or counterclockwise to set to “**OFF**”.
 - **ON:**
Sets reception emphasizing the visual.
 - **OFF:**
Sets the diver setting to OFF.
4. Press the **[T]** button to return to the previous mode.

Connect with 5.1ch Surround Decoder (DVH920/DVH940)

■ DVH920

SET and 5.1ch Surround Decoder connect with RCA pin cable (sold separately)

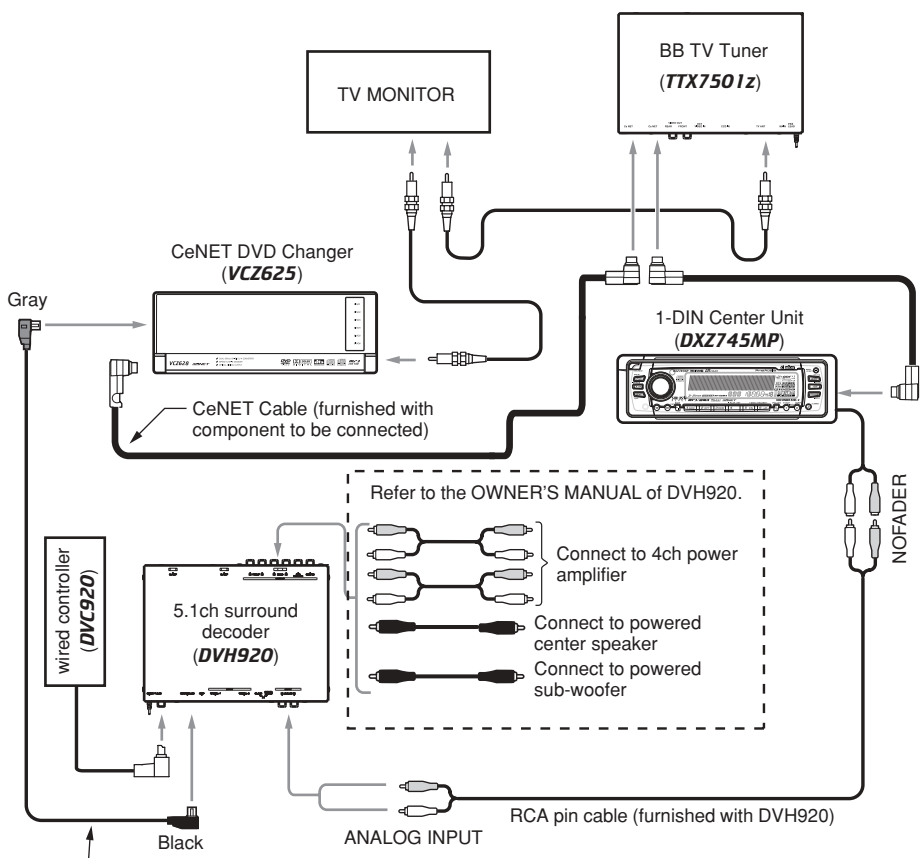

Optical Digital cable (sold separately)

DCA-005 (5 m) (furnished with DVH920)

DCA-008 (1.5 m)

Connect properly in accordance with color of connectors

Set the 5.1ch surround decoder's [STAND-ALONE / SLAVE] switch to the [STAND-ALONE] position.

SLAVE  STAND ALONE

■ DVH940

SET and 5.1ch Surround Decoder connect with RCA pin cable (sold separately)

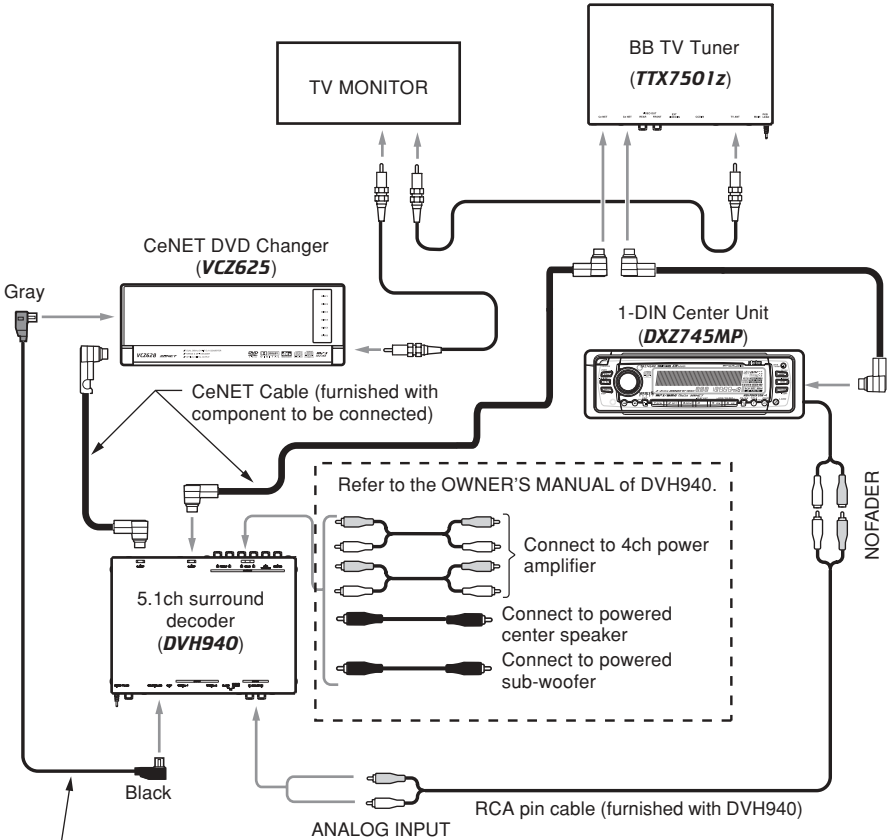

Optical Digital cable (sold separately)

DCA-005 (5 m) (furnished with DVH940)

DCA-008 (1.5 m)

Connect properly in accordance with color of connectors

Set the 5.1ch surround decoder's [STAND-ALONE / SLAVE] switch to the [STAND-ALONE] position.

SLAVE  STAND ALONE

9. IN CASE OF DIFFICULTY

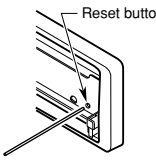
	Problem	Cause	Measure
General	Power does not turn on. (No sound is produced.)	Fuse is blown.	Replace with a fuse of the same amperage. If the fuse blows again, consult your store of purchase.
		Incorrect wiring.	Consult your store of purchase.
	No sound output when operating the unit with amplifiers or power antenna attached.	Power antenna lead is shorted to ground or excessive current is required for remote-on the amplifiers or power antenna.	<ol style="list-style-type: none"> 1. Turn the unit off. 2. Remove all wires attached to the power antenna lead. Check each wire for a possible short to ground using an ohm meter. 3. Turn the unit back on. 4. Reconnect each amplifier remote wire to the power antenna lead one by one. If the amplifiers turn off before all wires are attached, use an external relay to provide remote-on voltage (excessive current required).
	Nothing happens when buttons are pressed. Display is not accurate.	The microprocessor has malfunctioned due to noise, etc.	Turn off the power, then press the [RELEASE] button and remove the DCP. Press the reset button for about 2 seconds with a thin rod. 
		DCP or main unit connectors are dirty.	Wipe the dirt off with a soft cloth moistened with cleaning alcohol.
	No sound heard.	The speaker protection circuit is operating.	<ol style="list-style-type: none"> 1. Turn down sound volume. Function can also be restored by turning the power off and on again. (Speaker volume is reduced automatically when the speaker protection circuit operates). 2. If the sound is muted again, consult our service department.
CD/MP3/WMA	No sound heard.	MP3/WMA files are absent in a disc.	Write MP3/WMA files onto the disc properly.
		Files are not recognized as an MP3/WMA file.	Use MP3/WMA files encoded properly.
		File system is not correct.	Use ISO9660 level 1, 2 or JOLIET or Romeo file system.
	Sound skips or is noisy.	Disc is dirty.	Clean the disc with a soft cloth.
		Disc is heavily scratched or warped.	Replace with a disc with no scratches.
Sound is cut or skipped. Noise is generated or noise is mixed with sound.	MP3/WMA files are not encoded properly.	Use MP3/WMA files encoded properly.	

	Problem	Cause	Measure
CD/MP3/WMA	Sound is bad directly after power is turned on.	Water droplets may form on the internal lens when the car is parked in a humid place.	Let dry for about 1 hour with the power on.
	Wrong filename	File system is not correct.	Use ISO9660 level 1, 2 or JOLIET or Romeo file system.
	Play list play is not performed.	File name or extension is not correct.	Use alphanumeric/ASCII characters for MP3/WMA file name. Use “.M3U” for the file extension of a play list.

10. ERROR DISPLAYS

If an error occurs, one of the following displays is displayed.
Take the measures described below to eliminate the problem.

	Error Display	Cause	Measure
CD/MP3/WMA	ERROR 2	A CD is caught inside the CD deck and is not ejected.	This is a failure of CD deck's mechanism and consult your store of purchase.
	ERROR 3	A CD cannot be played due to scratches, etc.	Replace with a non-scratched, non-warped-disc.
	ERROR 6	A CD is loaded upside-down inside the CD deck and does not play.	Eject the disc then reload it properly.
CD changer	ERROR 2	A CD inside the CD changer is not loaded.	This is a failure of CD changer's mechanism and consult your store of purchase.
	ERROR 3	A CD inside the CD changer cannot be played due to scratches, etc.	Replace with a non-scratched, non-warped disc.
	ERROR 6	A CD inside the CD changer cannot be played because it is loaded upside-down.	Eject the disc then reload it properly.
DVD changer	ERROR 2	A DISC inside the DVD changer cannot be played.	This is a failure of DVD mechanism and consult your store of purchase.
	ERROR 3	A DISC cannot be played due to scratches, etc.	Retry or replace with a non-scratched, non-warped-disc.
	ERROR 6	A DISC inside the DVD changer cannot be played because it is loaded upside-down.	Eject the disc then reload it properly
	ERROR P	Parental level error	Set the correct Parental level.
	ERROR R	Region code error	Eject the disc and replace correct region code disc.
General	AMP GUARD	The speaker protection circuit is operating. During this operation, if any volume operation is performed, the display shows "AMP GUARD".	<ol style="list-style-type: none"> 1. Turn down sound volume. Function can also be restored by turning the power off and on again. (Speaker volume is reduced automatically when the speaker protection circuit operates). 2. If the sound is muted again, consult our service department.

If an error display other than the ones described above appears, press the reset button. If the problem persists, turn off the power and consult your store of purchase.

11. SPECIFICATIONS

FM Tuner

Frequency Range:
87.9 MHz to 107.9 MHz

Usable Sensitivity:
9 dBf

50dB Quieting Sensitivity:
15 dBf

Alternate Channel Selectivity:
70 dB

Stereo Separation (1 kHz):
35 dB

Frequency Response (± 3 dB):
30 Hz to 15 kHz

AM Tuner

Frequency Range:
530 kHz to 1710 kHz

Usable Sensitivity:
25 μ V

CD Player

System:
Compact disc digital audio system

Usable Discs:
Compact disc

Frequency Response (± 1 dB):
5 Hz to 20 kHz

Signal to Noise Ratio (1 kHz):
100 dB

Dynamic Range (1 kHz):
95 dB

Harmonic Distortion:
0.01%

Note:

- *Specifications and design are subject to change without notice for further improvement.*

Audio

Maximum Power Output:
212 W (53 W \times 4 ch)

Continuous Average Power Output:
18 W \times 4, into 4 Ω 20 Hz to 20 kHz, 1%THD

Bass Control Action (50 Hz/80 Hz/120 Hz):
+16 dB, -12 dB

Treble Control Action (8 kHz/12 kHz):
 ± 12 dB

Line Output Level (CD 1 kHz):
4 V

General

Power Supply Voltage:
14.4 V DC (10.8 to 15.6 V allowable), negative ground

Current Consumption:
Less than 15 A

Speaker Impedance:
4 Ω (4 Ω to 8 Ω allowable)

Weight / Source unit:
2.75 lb. (1.6 kg)

Weight / Remote control unit:
1 oz. (30 g) (including battery)

Dimensions / Source unit:
7" (Width) \times 2" (Height) \times 6-1/8" (Depth)
[178 (W) \times 50 (H) \times 155 (D) mm]

Dimensions / Remote control unit:
1-3/4" (Width) \times 4-5/16" (Height) \times 1-1/8" (Depth)
[44 (W) \times 110 (H) \times 27 (D) mm]

Clarion Co., Ltd.

All Rights Reserved. Copyright © 2003: Clarion Co., Ltd.
Printed in China / Imprimé en Chine / Impreso en China

PE-2619B
280-8000-00

clarion

Installation/Wire Connection Guide
Manuel d'installation et de connexion
Guía de instalación/conexión de cables

English Français Español

1. BEFORE STARTING / PRÉPARATIFS / ANTES DE COMENZAR

1. This set is exclusively for use in cars with a negative ground, 12 V power supply.
2. Read these instructions carefully.
3. Be sure to disconnect the battery "⊖" terminal before starting. This is to prevent short circuits during installation. (Figure 1)

1. Cet appareil est exclusivement destiné à être utilisé dans les voitures avec une alimentation 12 V à masse négative.
2. Lire ces instructions attentivement.
3. S'assurer de débrancher la borne "⊖" de la batterie avant de commencer. Cela évitera les court-circuits pendant l'installation. (Figure 1)

1. Esta unidad ha sido diseñada para utilizarse exclusivamente en automóviles con fuente de alimentación de 12 V, y negativo a masa.
2. Lea cuidadosamente estas instrucciones.
3. Antes de comenzar, cerciórese de desconectar el terminal "⊖" de la batería. Esto es para evitar cortocircuitos durante la instalación. (Figura 1)

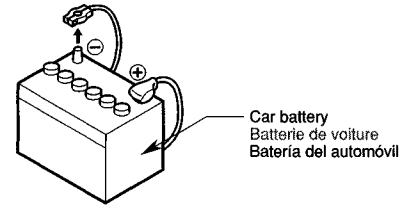

Figure 1 / Figure 1 / Figura 1

English Français Español

2. CAUTIONS ON INSTALLATION / PRÉCAUTIONS AU SUJET DE L'INSTALLATION / PRECAUCIONES PARA LA INSTALACIÓN

1. Prepare all articles necessary for installing the source unit before starting.
2. Install the unit within 30° of the horizontal plane. (Figure 2)
3. If you have to do any work on the car body, such as drilling holes, consult your car dealer beforehand.
4. Use the enclosed screws for installation. Using other screws can cause damage. (Figure 3)

1. Avant de commencer, préparer toutes les pièces nécessaires pour installer l'appareil pilote.
2. Installer l'appareil avec un angle inférieur à 30° par rapport à l'horizontal. (Figure 2)
3. S'il est nécessaire d'effectuer certains travaux sur la carrosserie comme percer des trous, consulter d'abord votre concessionnaire automobile.
4. Utiliser les vis fournies pour l'installation. L'utilisation d'autres vis peut causer des dommages. (Figure 3)

1. Antes de comenzar, prepare todos los elementos necesarios para instalar la unidad fuente.
2. Instale la unidad con un ángulo de 30° sobre el plano horizontal. (Figura 2)
3. Si tiene que realizar cualquier trabajo en la carrocería, como taladrado de orificios, etc., consulte al proveedor de su automóvil.
4. Use los tornillos incluidos para la instalación. El uso de otros tornillos puede causar daños. (Figura 3)

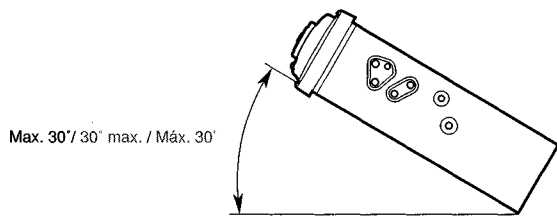

Figure 2 / Figure 2 / Figura 2

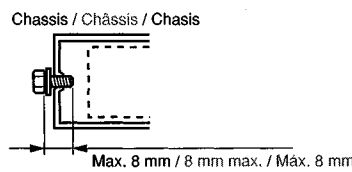
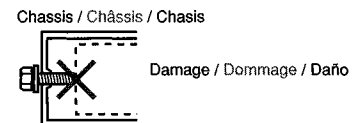

Figure 3 / Figure 3 / Figura 3



English Français Español

3. INSTALLING THE SOURCE UNIT / INSTALLATION DE L'APPAREIL PILOTE / INSTALACIÓN DE LA UNIDAD FUENTE

■ Universal Mount

1. Place the universal mounting bracket into the instrument panel, use a screwdriver to bend each stopper of the universal mounting bracket inward, then secure the stopper as shown in Figure 4.
2. Wire as shown in Section 6.
3. Insert the source unit into the universal mounting bracket until it locks.
4. Take care of the top and bottom of the outer escutcheon and mount it so that all the hooks are locked.

■ Montage universel

1. Placer le support de montage universel dans le tableau de bord, utiliser un tournevis pour replier vers l'extérieur chaque languette du support de montage universel, puis fixer les languettes comme montré sur la Figure 4.
2. Câbler comme montré dans la Section 6.
3. Insérer l'appareil pilote dans le support de montage universel jusqu'à ce qu'il soit bloqué.
4. Repérer le haut et le bas de l'écusson extérieur et le monter de manière que tous les crochets soient verrouillés.

■ Montaje universal

1. Coloque el soporte de montaje universal en el tablero de instrumentos, utilice un destornillador para doblar cada retén del soporte de montaje universal hacia adentro, y después asegure el retén como se muestra en la Figura 4.
2. Conecte los cables como se muestra en la Sección 6.
3. Inserte la unidad fuente en el soporte de montaje universal hasta que quede enganchado.
4. Tenga cuidado con la partes superior e inferior de la pieza ornamental exterior, y móntela de forma que todos los ganchos queden bloqueados.

Notes:
 1) Some car models require special mounting kits for proper installation. Consult your Clarion dealer for details.
 2) Fasten the front stopper securely to prevent the source unit from coming loose.

Remarques:
 1) Certains modèles de voiture nécessitent un kit de montage spécial pour une installation correcte. Consulter le revendeur Clarion pour les détails.
 2) Serrer fermement la languette avant pour éviter que l'appareil pilote ne se desserre.

Notas:
 1) Algunos modelos de automóviles requieren juegos de montaje especiales para realizar la instalación apropiada. Solicite los detalles a su proveedor Clarion.
 2) Apriete con seguridad el retén frontal para evitar que se afloje la unidad fuente.

- Console opening dimensions
- Dimensions d'ouverture de la console
- Dimensiones de la abertura de la consola

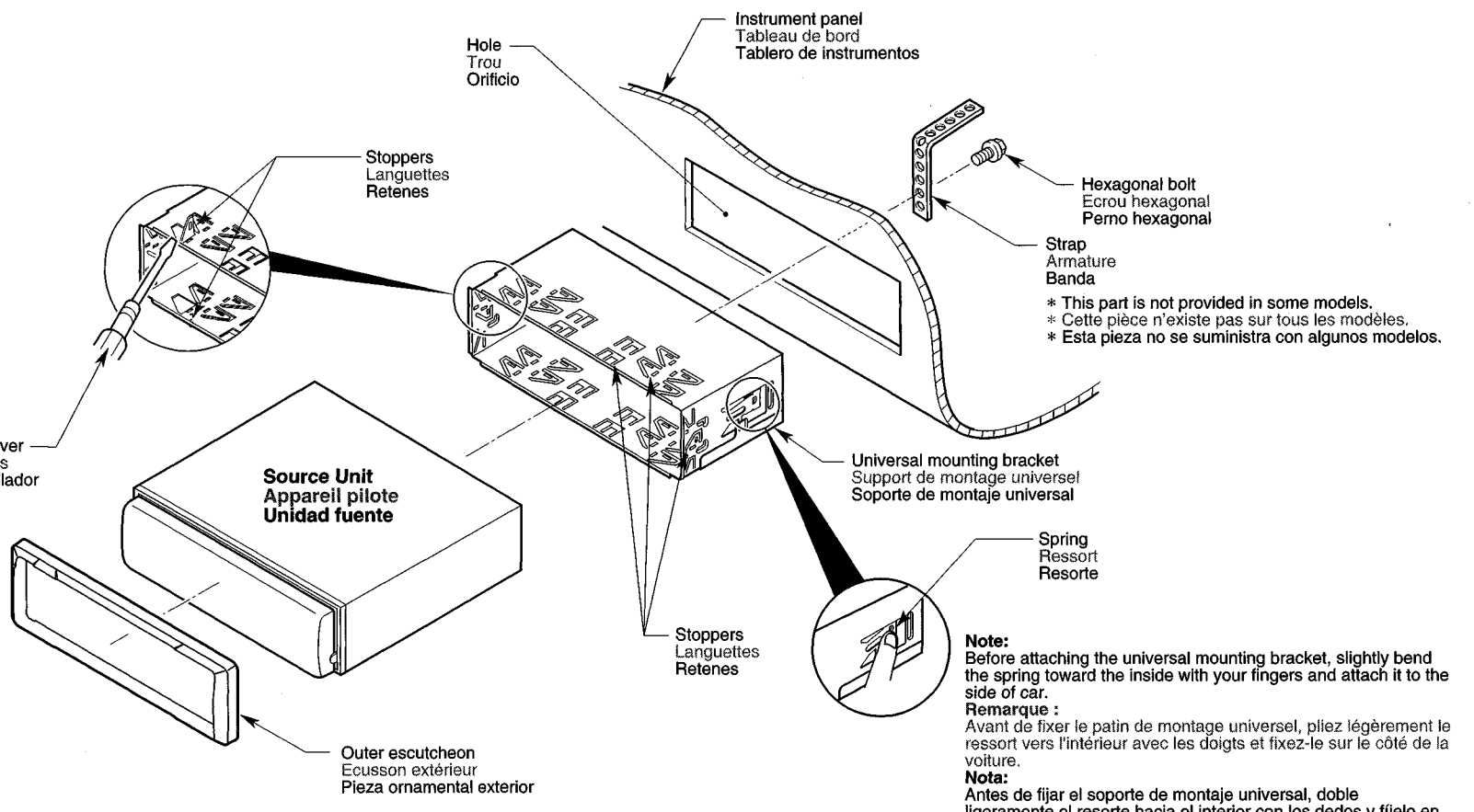
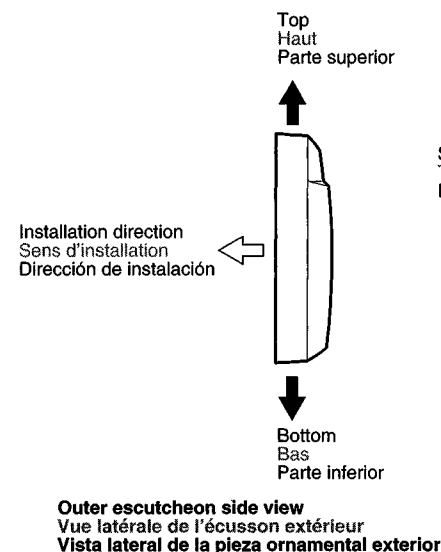
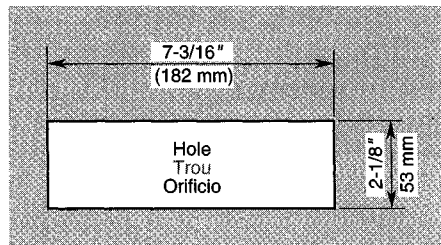

Figure 4 / Figure 4 / Figura 4

■ PRECAUTION

Remove the stopper following the procedures below when this source unit is installed without the universal mounting bracket.

1. Remove the screw from the source unit (Figure 5).
2. Remove the stopper from the source unit (Figure 6).
3. Install the remove screw to the source unit (Figure 7).

* Securely attach the screw.

Note:
Store the removed stopper in a safe place together with the Instruction Manual.

■ PRECAUCION

Retire el tapón después de los siguientes procedimientos indicados abajo cuando esta unidad de la fuente está instalada sin el soporte de montaje universal.

1. Quite el tornillo de la unidad de la fuente (Figura 5).
2. Quite el tapón de la unidad de la fuente (Figura 6).
3. Instale el tornillo retirado de la unidad de la fuente (Figura 7).

* Apriete firmemente el tornillo.

Nota:
Guarda el tapón retirado en un lugar seguro junto con el Manual de Instrucciones.

■ Précaution

Retirer la languette en procédant comme suit pour installer le module source sans la patte de montage universel.

1. Retirer la vis du module source (Figure 5).
2. Retirer la languette du module source (Figure 6).
3. Fixer la vis ainsi retirée sur le module source (Figure 7).

* Fixer la vis à fond.

Remarque:
Ranger la languette retirée en lieu sûr avec le mode d'emploi.

Example 1/Exemple 1/Ejemplo 1

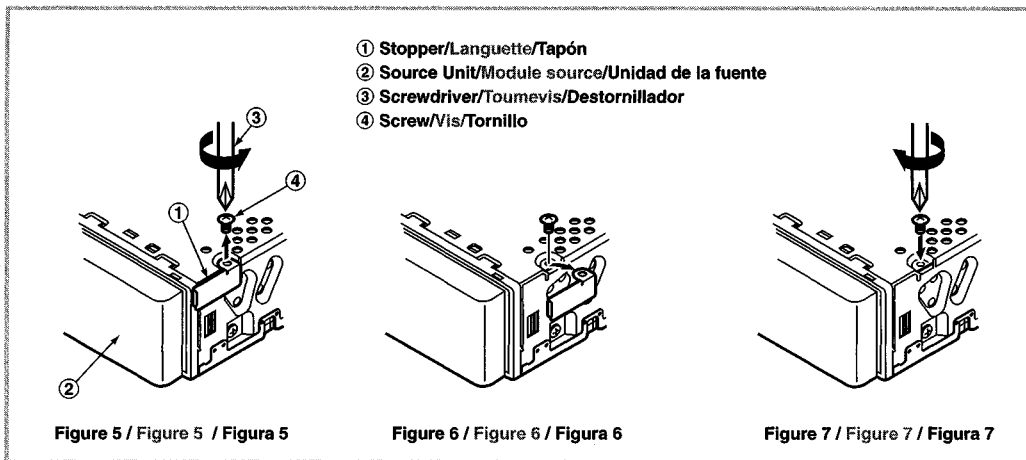

Example 2/Exemple 2/Ejemplo 2

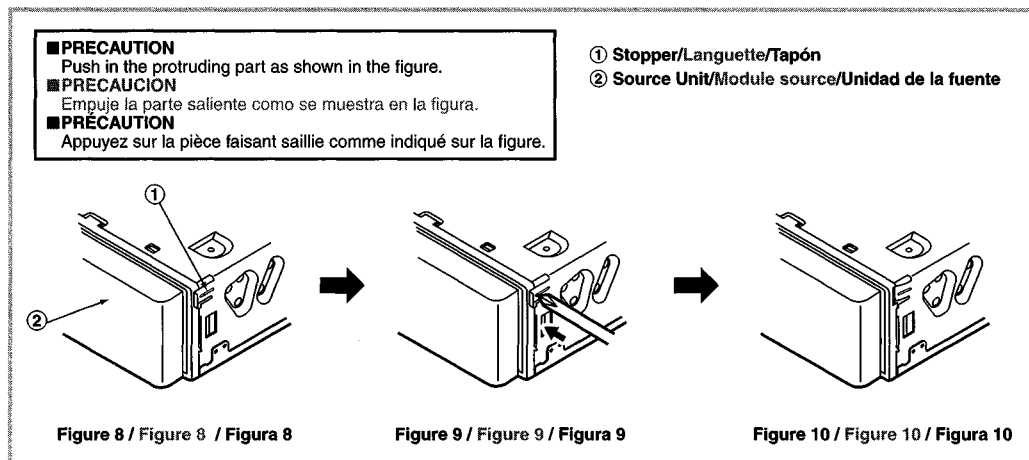

■ Fixed Mount (Using the bracket originally equipped in vehicle)

This unit is designed for fixed installation in the dashboard.
If the vehicle is equipped with a factory-installed radio, install the source unit with the parts and screws marked (*). (Figure 11)
If the vehicle is not equipped with a factory-installed radio, obtain an installation kit to install the source unit in the following procedure.

1. Secure the mounting brackets to the chassis as shown in Figure 11. When the source unit is installed without the universal mounting bracket, holes exist; modification, such as drilling new holes, of the mounting brackets may be required for other models.
2. Wire as shown in Installation (Section 6).
3. Secure the unit in the dashboard, and then reassemble the dashboard and the center panel.

■ Montage fixe (Avec la patte fixée à l'origine dans le véhicule)

L'appareil est conçu pour une installation fixe dans le tableau de bord.
Si le véhicule est équipé d'une radio installée en usine, installer le module source avec les pièces et les vis marquées d'un astérisque (*). (Figure 11)
Si le véhicule n'est pas équipé d'une radio installée en usine, se procurer le kit d'installation pour installer le module source en procédant comme suit.

1. Fixer les pattes de montage sur la carrosserie comme indiqué à la Figure 11. Pour installer le module source sans patte de montage universel, les orifices existent déjà; pour les autres modèles, il faudra peut-être modifier les pattes de montage (par exemple percer de nouveaux orifices).
2. Effectuer les câblages comme indiqué dans Installation (Section 6).
3. Fixer l'appareil dans le tableau de bord, puis remonter le tableau de bord et le panneau central.

■ Montura fija (Usando el soporte originalmente equipado en el vehículo)

Esta unidad ha sido diseñada para la instalación fija en el tablero de instrumentos.
Si el vehículo está equipado con una radio instalada en fábrica, instale la unidad de la fuente con las piezas los tornillos marcados con (*). (Figura 11)
Si el vehículo no está equipado con una radio instalada en fábrica, obtenga un juego de instalación para instalar la unidad de la fuente mediante el procedimiento que se da a continuación:

1. Asegure los soportes de montaje al chasis como se muestra en la Figura 11. Cuando la unidad de la fuente está instalada sin el soporte de montaje universal, existiendo agujeros, puede requerirse una modificación para otros modelos, tal como perforación de nuevos agujeros.
2. Realice el cableado tal como se muestra en instalación (Sección 6).
3. Asegure la unidad en el tablero de instrumentos, y luego vuelva a armar el tablero de instrumentos y el panel central.

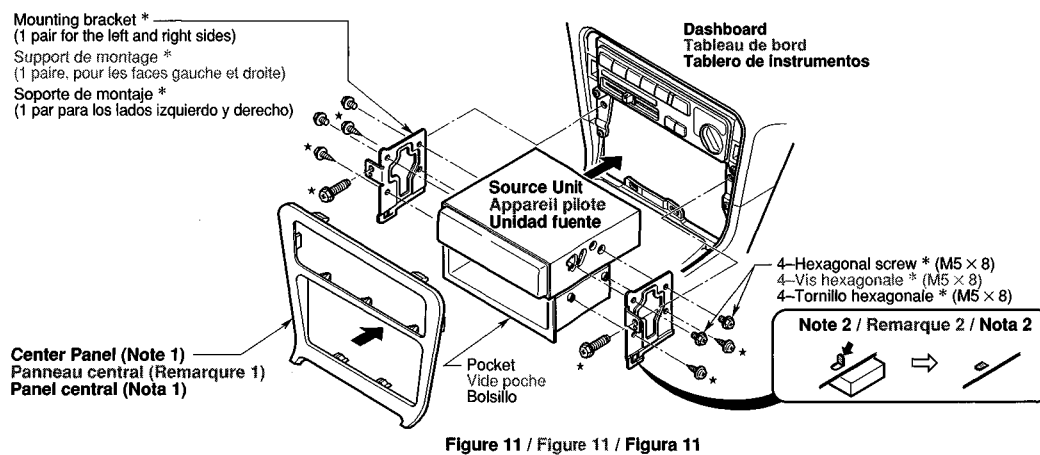

* : The parts and SCREW with this mark are used to install radio or included in the installation kit.

★ : The screws with this mark are originally attached to the vehicle.

Note 1: In some cases, the center panel may require some modification (trimming, filling, etc.).

Note 2: If a hook on the installation bracket interferes with the unit, bend and flatten it with a nipper or a similar tool.

* : Les pièces et la VIS portant cette marque servent pour l'installation de la radio ou sont fournies avec le kit d'installation.

★ : Les vis portant cette marque sont montées d'origine dans le véhicule.

Remarque 1: Dans certains cas, il sera parfois nécessaire de modifier le panneau central (découpe, remplissage, etc.).

Remarque 2: Si le crochet de la patte d'installation interfère avec l'appareil, le plier et l'aplatir à l'aide d'une pince par exemple.

* : Las piezas y los tornillos con esta marca se utilizan para instalar una radio o están incluidos en el juego de instalación.

★ : Los tornillos con esta marca están originalmente sujetos al vehículo.

Nota 1: En algunos casos, el panel central puede requerir cierta modificación (Recorte, relleno, etc.).

Nota 2: Si un gancho en el soporte de instalación interfiere con la unidad, dóbelo y aplástelo con una pinzas de corte u otra herramienta especial.

English Français Español

4. REMOVAL OF THE SOURCE UNIT / DEPOSE DE L'APPAREIL PILOTE / DESMONTAJE DE LA UNIDAD FUENTE

1. When removing the source unit, disassemble it in the reverse of the order in Section "3. INSTALLING THE SOURCE UNIT".
2. Remove the Detachable Control Panel (DCP).
* For instructions on removing the DCP, refer to the owner's manual.
3. Press the outer escutcheon upward and remove it. (Figure 12)
4. Insert and lock the hook plates. (Figure 13)
5. Pull the hook plates to remove the source unit.

1. Lors de la dépose de l'appareil pilote, démonter dans l'ordre inverse de la Section "3. INSTALLATION DE L'APPAREIL PILOTE".
2. Déposer le clavier de commande amovible (DCP).
* Pour les instructions sur le retrait du clavier de commande amovible (DCP), se référer au mode d'emploi.
3. Presser l'écusson extérieur vers le haut et le retirer. (Figure 12)
4. Insérer et verrouiller les plaques à crochet. (Figure 13)
5. Tirer sur les plaques à crochet pour retirer l'appareil pilote.

1. Para desmontar la unidad fuente, realice el procedimiento inverso al de la Sección "3. INSTALACIÓN DE LA UNIDAD FUENTE".
2. Desmonte el panel de control desmontable (DCP).
* Para instrucciones sobre cómo desmontar el DCP, consulte el manual de instrucciones.
3. Presione la pieza ornamental exterior hacia afuera y extráigala. (Figura 12)
4. Inserte y bloquee las placas de enganche. (Figura 13)
5. Tire de las placas de enganche para extraer la unidad fuente.

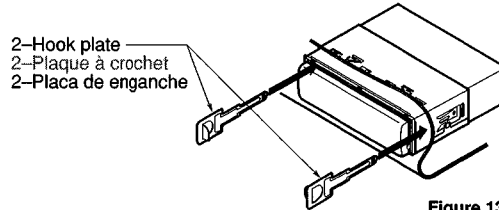
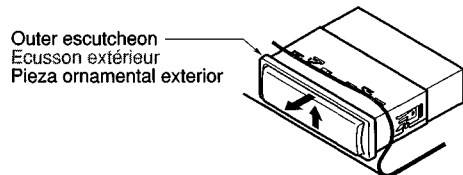

English Français Español

5. CAUTIONS ON WIRING / PRÉCAUTIONS AU SUJET DES CONNEXIONS / PRECAUCIONES PARA LA CONEXIÓN DE CABLES

1. Be sure to turn the power off when wiring.
2. Be particularly careful where you route the wires. Keep them well away from the engine, exhaust pipe, etc. Heat may damage the wires.
3. If the fuse should blow, check that the wiring is correct.
If it is, replace the fuse with a new one with the same amperage rating as the original one. (Figure 14)

Note:

There are various types of fuse holder. Do not let the battery side touch other metal parts.

4. Connect the CeNET extension cable fully and securely until it locks. When the CeNET extension cable is pulled, hold the slide cap part and pull it towards you.
* When the CeNET extension cable is extended or branches, use extension cable CCA-520 (2.5m) or CCA-521 (0.6m), or Y-adaptor CCA-519 (each of them is sold separately).
* Use the CeNET extension cable made by Clarion.
5. When the main power supply fuse in the car is 15 A or less, purchase an automotive cable that can withstand 15 A and supply this unit with power directly from the battery to ensure that the unit will operate normally.
Note that a fuse must be installed at a distance no longer than 30 cm from the cable battery terminal to prevent accidents.

1. S'assurer de mettre l'appareil hors circuit avant de faire le câblage.
2. Faire particulièrement attention lors de l'acheminement des fils. Les éloigner du moteur, des tuyaux d'échappement, etc. La chaleur risque d'endommager ces fils.
3. Si le fusible saute, vérifier si le câblage est correct.
Si le fusible est grillé, le remplacer par un fusible neuf de même ampérage que le fusible d'origine. (Figure 14)

Remarque:

Il y a différent type de porte-fusible. La borne du côté batterie ne doit pas toucher d'autres pièces métalliques.

4. Connecter le câble d'extension CeNET complètement et solidement jusqu'à ce qu'il soit verrouillé. Pour tirer le câble d'extension CeNET, tenir la partie coulissante du capuchon et tirer vers vous. AB
* Pour étendre ou dériver le câble d'extension CeNET, utiliser le câble d'extension CCA-520 (2,5 m [8 pieds]) ou CCA-521 (0,6 m [2 pieds]), ou l'adaptateur Y CCA-519 (ces câbles sont vendus séparément)
* Utiliser les câbles d'extension CeNET fabriqués par Clarion.
5. Si le fusible d'alimentation principale de la voiture est de 15 A ou moins, achetez un câble automobile qui peut supporter 15 A et alimenter cet appareil directement à partir de la batterie et assurer que l'appareil fonctionnera normalement.
Notez qu'un fusible doit être installé à une distance de moins 30 cm de borne de la batterie pour éviter tout accident.

1. Antes de hacer las conexiones, asegúrese de desconectar la alimentación de la unidad.
2. Sea especialmente cuidadoso al dirigir y fijar los cables. Manténgalos alejados del motor, tubo de escape, etc. El calor puede dañar los cables.
3. Si el fusible se quema, revise las conexiones.
Si está quemado, reemplace el fusible por otro nuevo con el mismo valor de amperaje que el original. (Figura 14)

Nota:

Existen varios tipos de portafusibles. No permita que el terminal del lado de la batería toque otras partes metálicas.

4. Conecte el cable prolongador CeNET completa y seguramente hasta que chasquee. Para desconectar el cable, sujete la parte de la tapa deslizable y tire hacia usted.
* Para prolongar o ramificar el cable prolongador CeNET, utilice un cable prolongador CCA-520 (2,5 m) o CCA-521 (0,6 m), o un adaptador en Y CCA-519 (vendidos aparte).
* Utilice un cable prolongador CeNET fabricado por Clarion.
5. Cuando el fusible de alimentación principal del automóvil sea de 15 A o menos, adquiera un cable para automóvil que pueda resistir 15 A y alimente esta unidad directamente desde la batería para cerciorarse de que pueda funcionar normalmente.
Tenga en cuenta que para evitar accidentes, deberá instalar un fusible en el cable que va a terminales de la batería a una distancia no superior a 30 cm.

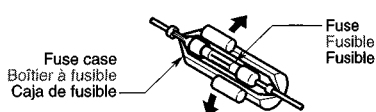

6. WIRE CONNECTIONS / CONNECTIQUE / CONEXIÓN DE CABLES

DXZ945MP/DXZ745MP

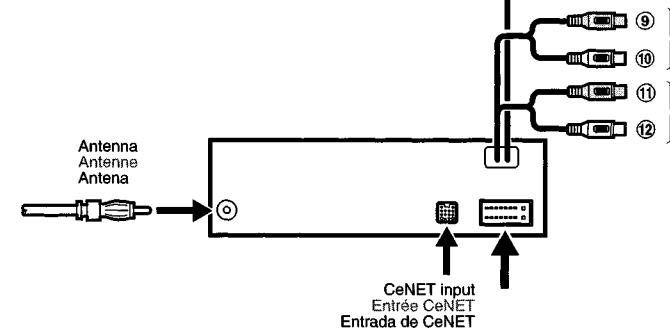

To external amplifier
 * To eliminate audio short circuits, do not remove the caps of unused RCA cables.
CAUTION: Please make sure when connecting external power amplifier, that you properly, to the car chassis, ground the amplifier. If this is not done, severe damage to the source unit may happen.
Vers un amplificateur externe
 * Pour supprimer les courts-circuits audio, ne pas retirer les capuchons des câbles RCA non utilisés.
ATTENTION: Lorsque vous raccordez un ampli de puissance externe, faites bien attention à mettre correctement l'amplificateur à la masse sur le châssis de la voiture. Sinon, vous risquez d'endommager gravement l'appareil pilote.
A un amplificador externo
 * Para eliminar los cortocircuitos de audio, no quite los casquillos protectores de los cables RCA no utilizados.
PRECAUCIÓN: Cuando conecte un amplificador de potencia externo, cerciórese de ponerlo adecuadamente a masa en el chasis de su automóvil. Si no lo hiciese, la unidad fuente podría dañarse seriamente.

DXZ845MC

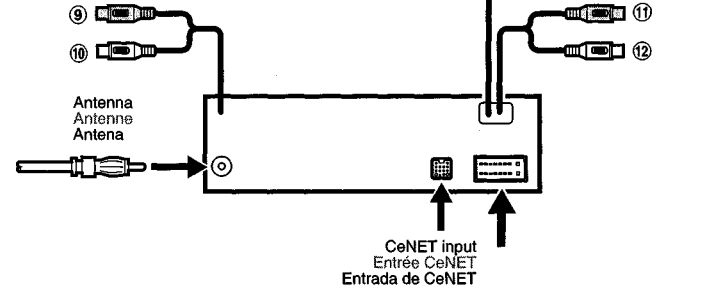

DXZ645MP

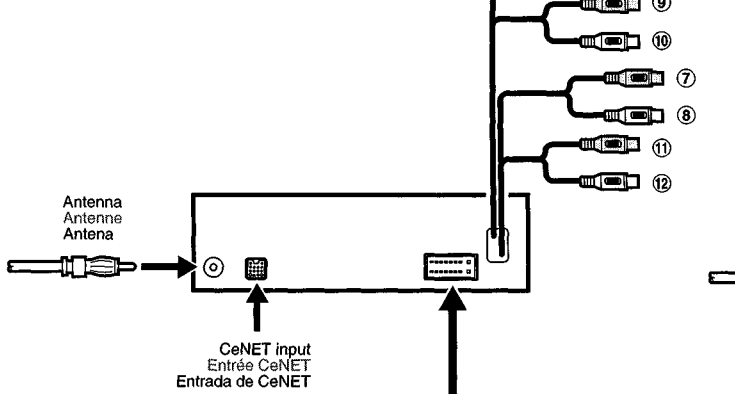

DXZ545MP

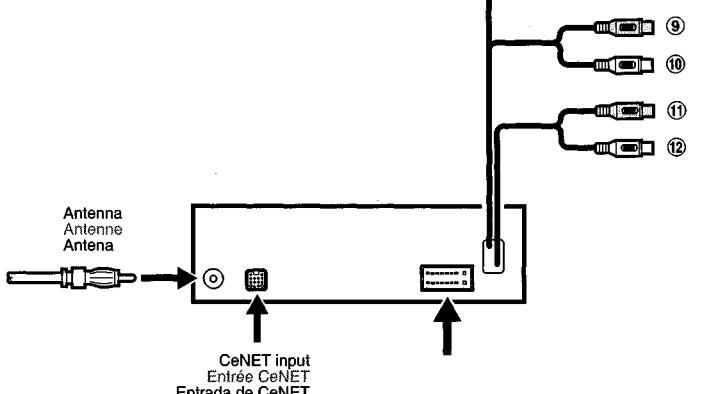

DXZ445

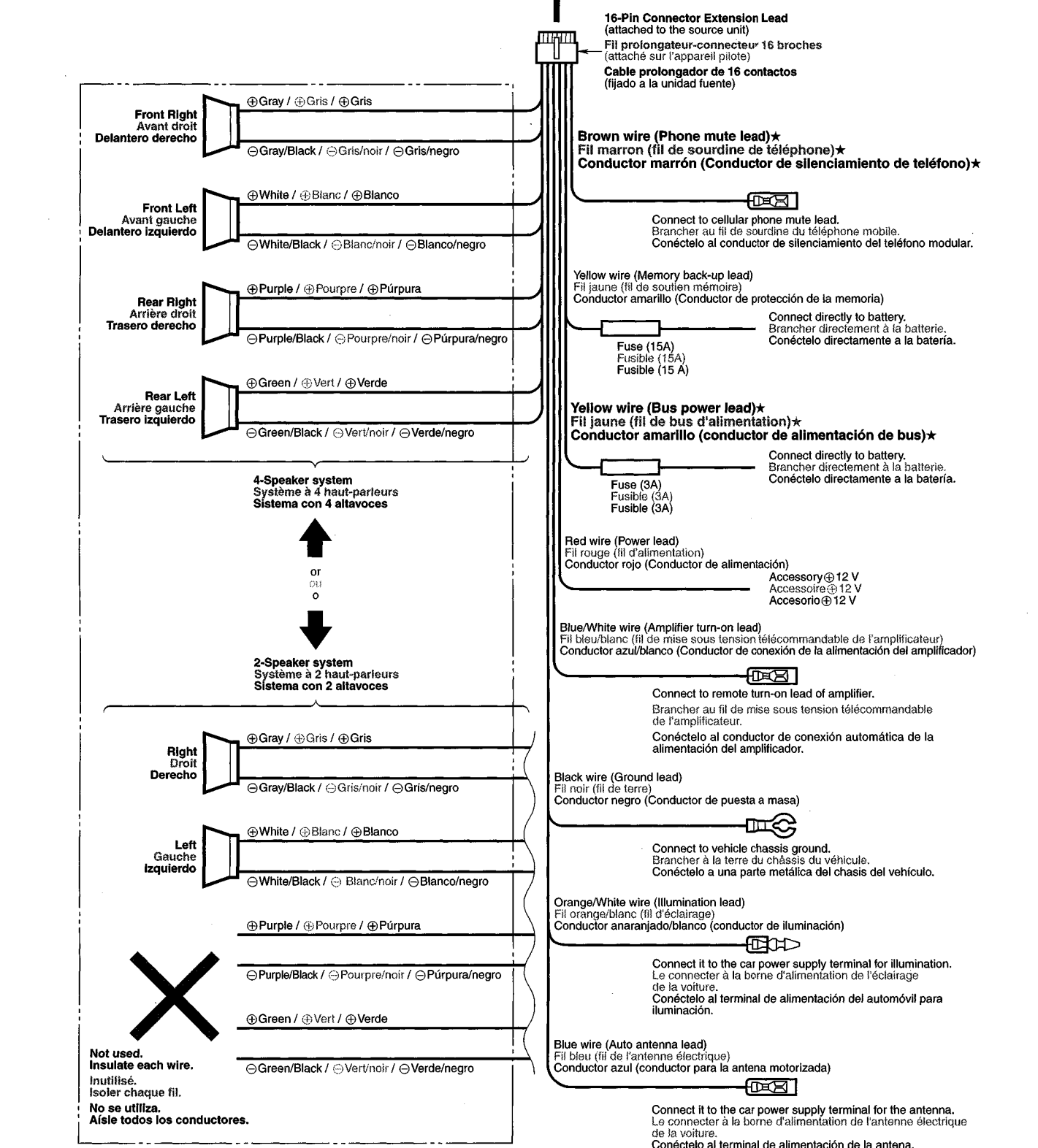
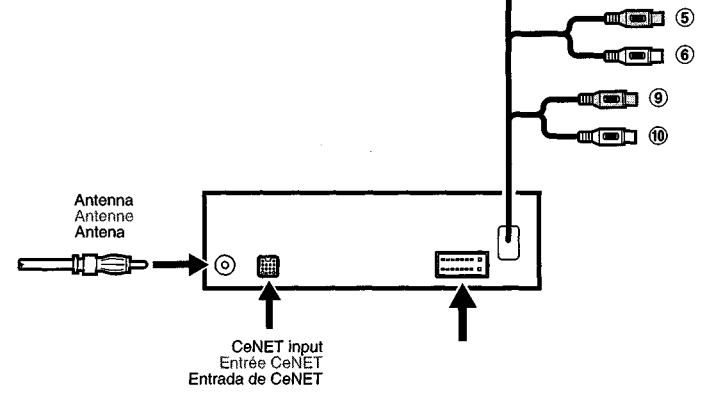

Note:
 Some units do not have connecting leads or jacks.
 (Refer to ★.)
Remarque:
 Certains appareils n'ont pas de conducteurs de connexion ou de prises.
 (Voir ★.)
Nota:
 Algunas unidades no tienen cables de conexión ni conectores.
 (Refiérase a ★.)

English

No.	Description
①	FRONT RIGHT Gray (Red)
②	FRONT LEFT Gray (White)
③	REAR RIGHT Black (Red)
④	REAR LEFT Black (White)
⑤	REAR RIGHT/(SUB WOOFER RIGHT) Black (Red)
⑥	REAR LEFT/(SUB WOOFER LEFT) Black (White)
⑦	SUB WOOFER RIGHT Violet (Red)
⑧	SUB WOOFER LEFT Violet (White)
⑨	AUX INPUT RIGHT Red (Red)
⑩	AUX INPUT LEFT Red (White)
⑪	2-ZONE OUTPUT RIGHT Green (Red)
⑫	2-ZONE OUTPUT LEFT Green (White)

Français

No.	Description
①	AVANT DROIT Gris (Rouge)
②	AVANT GAUCHE Gris (Blanc)
③	ARRIERE DROIT Noir (Rouge)
④	ARRIERE GAUCHE Noir (Blanc)
⑤	ARRIERE DROIT/(SUBWOOFER DROIT) Noir (Rouge)
⑥	ARRIERE GAUCHE/(SUBWOOFER GAUCHE) Noir (Blanc)
⑦	SUBWOOFER DROIT Violet (Rouge)
⑧	SUBWOOFER GAUCHE Violet (Blanc)
⑨	ENTREE AUX droite (Rouge)
⑩	ENTREE AUX gauche (Blanc)
⑪	2-ZONE OUTPUT DROIT VERT (rouge)
⑫	2-ZONE OUTPUT GAUCHE VERT (blanc)

Español

No.	Descripción
①	DELANTERO DERECHO Gris (Rojo)
②	DELANTERO IZQUIERDA Gris (Blanco)
③	TRASERO DERECHO Negro (Rojo)
④	TRASERO IZQUIERDA Negro (Blanco)
⑤	TRASERO DERECHO/(ALTAVOZ DE SUBGRAVES DERECHO) Negro (Rojo)
⑥	TRASERO IZQUIERDA/(ALTAVOZ DE SUBGRAVES IZQUIERDA) Negro (Blanco)
⑦	ALTAVOZ DE SUBGRAVES DERECHO Violado (Rojo)
⑧	ALTAVOZ DE SUBGRAVES IZQUIERDA Violado (Blanco)
⑨	Entrada auxiliar (AUX INPUT) del canal derecho (Rojo)
⑩	Entrada auxiliar (AUX INPUT) del canal izquierdo (Blanco)
⑪	SALIDA DE ZONA 2 DERECHO VERDE (Rojo)
⑫	SALIDA DE ZONA 2 IZQUIERDO VERDE (Blanco)

7. SYSTEM EXAMPLE/EXEMPLE DE SYSTEME/EJEMPLO DE SISTEMA

- Example of the system using an external amplifier (Audio Visual)
- Exemple de système utilisant un amplificateur extérieur. (audio-visuel)
- Ejemplo de sistema utilizando un amplificador externo (audiovisual)

■ DXZ945MP/DXZ745MP

■ DXZ845MC/DXZ645MP/DXZ545MP/DXZ445

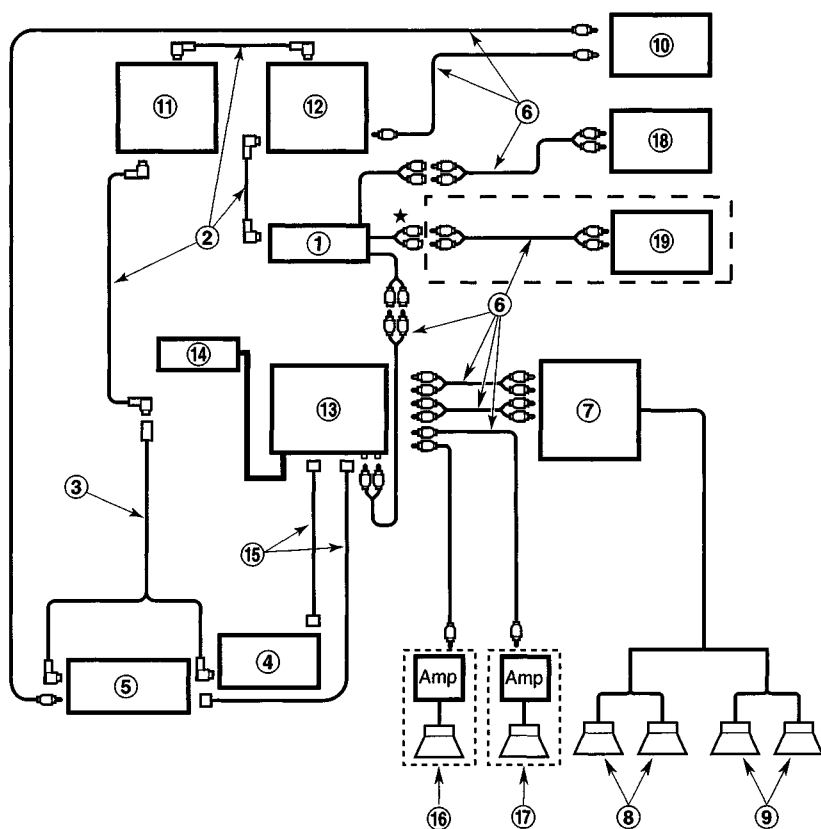
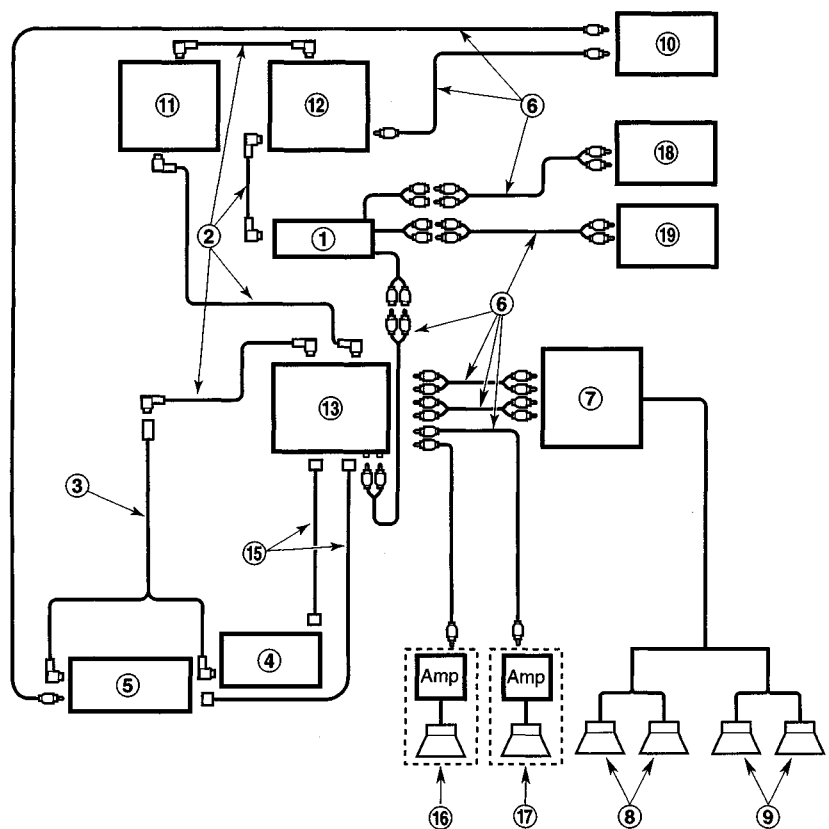

Note:
Use a CeNET extension cable that is less than 20 m in length. (including the Y-adaptor CCA-519.)
Remarque:
Utiliser un câble d'extension CeNET inférieur à 20 m de long (en comptant aussi l'adaptateur Y CCA-519).
Nota:
Utilice un cable prolongador CeNET de menos de 20 m de longitud (incluyendo el adaptador en Y CCA-519).

Note:
DXZ445 does not have a "2-ZONE OUTPUT" terminal. (Refer to ★.)
Remarque:
Le DXZ445 ne possède pas de borne "2-ZONE OUTPUT". (Voir ★.)
Nota:
El modelo DXZ445 no posee terminal "2-ZONE OUTPUT". (Refiérase a ★.)

- * This source unit can control a total of 2 changers except 2 DVD changers exist in the system.
- * L'appareil pilote est capable de commander 2 changeurs au total en plus des 2 changeurs de DVD qui existent dans le système.
- * Esta unidad fuente puede controlar en total 2 cambiadores excepto los 2 cambiadores de discos DVD del sistema.

English

①	Source unit
②	CeNET extension cable
③	Y-adaptor (sold separately)
④	CD changer
⑤	DVD changer
⑥	RCA extension cable (sold separately)
⑦	4-Channel power amplifier
⑧	Front speakers
⑨	Rear speakers
⑩	Monitor
⑪	SIRIUS satellite radio receiver
⑫	TV tuner module
⑬	5.1ch surround decoder
⑭	5.1ch surround decoder control unit
⑮	Optical connector cable
⑯	Center speaker (with amplifier)
⑰	Subwoofer (with amplifier)
⑱	External unit
⑲	Wireless head phone unit

Français

①	Appareil pilote
②	Câble d'extension CeNET
③	Adaptateur Y (vendu séparément)
④	Changeur de CD
⑤	Changeur de DVD
⑥	Câble de rallonge RCA (vendu séparément)
⑦	Amplificateur de puissance 4 canaux
⑧	Haut-parleurs avant
⑨	Haut-parleurs arrière
⑩	Moniteur
⑪	Récepteur radio satellite SIRIUS
⑫	Module tuner TV
⑬	Décodeur surround 5.1 canaux
⑭	Module de commande de décodeur surround 5.1 canaux
⑮	Câble de connexion optique
⑯	Haut-parleur central (avec amplificateur)
⑰	Subwoofer (avec amplificateur)
⑱	Appareil externe
⑲	Casque sans fil

Español

①	Unidad fuente
②	Cable prolongador CeNET
③	Adaptador en Y (vendido aparte)
④	Cambiador de discos compactos
⑤	Cambiador de DVD
⑥	Cable de extensión RCA
⑦	Amplificador de potencia de 4 canales
⑧	Altavoces delanteros
⑨	Altavoces traseros
⑩	Monitor
⑪	Sintonizador SIRIUS de recepción radio via satélite
⑫	Módulo sintonizador de televisión
⑬	Descodificador de 5.1ch surround
⑭	Unidad de control de Descodificador de 5.1ch surround
⑮	Cable conector óptico
⑯	Altavoz central (con amplificador)
⑰	Altavoz de subgraves (con amplificador)
⑱	Unidad externo
⑲	Unidad de auriculares inalámbricos

8. GENERAL CAUTIONS / PRÉCAUTIONS GÉNÉRALES / PRECAUCIONES GENERALES

1. Do not open the case. There are no user serviceable parts inside. If you drop anything into the unit during installation, consult your dealer or an authorized CLARION service center.
2. Use a soft, dry cloth to clean the case. Never use hard cloth, thinner, benzen, alcohol, etc. For tough dirt, apply a little cold or warm water to a soft cloth and wipe off the dirt gently.

1. Ne pas ouvrir le coffret. Il n'y a pas de pièces réparables par l'utilisateur à l'intérieur de l'appareil. Si un objet est tombé dans l'appareil pendant l'installation, consulter votre revendeur ou un service après-vente agréé CLARION.
2. Utiliser un chiffon doux et sec pour nettoyer le coffret, ne jamais utiliser un chiffon rigide, un diluant, du benzène, de l'alcool, etc. Pour enlever la saleté tenace, appliquer un peu d'eau froide ou tiède sur un chiffon doux et essuyer doucement la saleté.

1. No abra la caja. En el interior no hay piezas que pueda reparar el usuario. Si dentro de la unidad entra algo durante la instalación, consulte a su proveedor o a un centro de servicio autorizado por CLARION.
2. Para limpiar la caja, utilice un paño suave y seco. no use nunca un paño duro, diluidor de pintura, benceno, alcohol, etc. Para la suciedad resistente, aplique un poco de agua fría o caliente a un paño suave y frote suavemente la parte sucia.

IMPORTANT:
Improper installation may cause damage to your unit or car. If you do not have the appropriate experience, consult a qualified installer. Cutting chassis wire leads voids the warranty.

IMPORTANT:
Une installation incorrecte peut endommager l'appareil ou le véhicule. Si l'on ne possède pas les connaissances requises, consulter un installateur qualifié. Couper le fil du châssis annule la garantie.

IMPORTANTE:
La instalación inapropiada puede causar daños en su unidad o su automóvil. Si usted no posee la experiencia apropiada, consulte a un instalador cualificado. El corte de los conductores de puesta a masa (carrocería) anulará la garantía.



CLARION LIMITED WARRANTY

For USA and Canada only

If purchased from an authorized Clarion dealer, this product is warranted against all defects in materials and workmanship for a period of one (1) year from the date of original purchase. Clarion ProAudio products, except for speakers, are covered by a two (2) year limited warranty when purchased from and installed by an authorized Clarion dealer. **ALL PURCHASES OF CLARION PRODUCTS FROM NON-AUTHORIZED CLARION DEALERS ARE SUBJECT TO FURTHER WARRANTY RESTRICTIONS AS DESCRIBED BELOW.**

The conditions of this limited warranty and the extent of responsibility of Clarion Corporation of America ("Clarion") under this limited warranty are as follows :

1. **PROOF OF DATE OF PURCHASE WILL BE REQUIRED FOR WARRANTY SERVICE OF THIS PRODUCT. IN THE CASE OF THE TWO (2) YEAR LIMITED WARRANTY FOR CLARION PROAUDIO PRODUCT, PROOF OF INSTALLATION BY AN AUTHORIZED CLARION DEALER IS REQUIRED. INFORMATION ABOUT CLARION AUTHORIZED WARRANTY SERVICE CENTERS MAY BE OBTAINED BY CONTACTING OR WRITING CLARION AT THE ADDRESS LISTED BELOW.**
2. This limited warranty will become void if service performed by anyone other than an approved Clarion Warranty Service Center results in damage to the product.
3. This limited warranty does not apply to any product which has been subject to misuse, neglect or accident, or which has had the serial number altered, defaced or removed, or which has been connected, installed, adjusted or repaired, other than in accordance with the instructions furnished by Clarion.
4. This limited warranty does not cover car static or other electrical interferences, tape head or laser pick-up cleaning or adjustments, or labor costs for the removal or reinstallation of the unit for repair.
5. The sole responsibility of Clarion under this limited warranty shall be limited to the repair of the product or replacement of the product, at the sole discretion of Clarion.
6. Product must be shipped in its original carton or equivalent carton, fully insured, with shipping charges prepaid. Clarion will not assume any responsibility for any loss or damage incurred in shipping.
7. **CLARION PRODUCTS, INCLUDING PROAUDIO PRODUCTS, PURCHASED FROM A SOURCE OTHER THAN AN AUTHORIZED CLARION DEALER, INCLUDING ANY AND ALL PURCHASES VIA THE INTERNET FROM A NON INTERNET AUTHORIZED CLARION DEALER, SHALL NOT BE COVERED BY ANY CLARION LIMITED WARRANTY TO THE EXTENT ALLOWED BY APPLICABLE LAW. IN THE EVENT AND TO THE EXTENT APPLICABLE LAW PROHIBITS ELIMINATION OF WARRANTIES UNDER THESE CIRCUMSTANCES, THE APPLICABLE LIMITED WARRANTY PERIOD SHALL BE DEEMED TO BE FIFTEEN (15) DAYS FROM THE DATE OF ORIGINAL PURCHASE.**
8. ALL IMPLIED WARRANTIES EXCEPT TO THE EXTENT PROHIBITED BY APPLICABLE LAW SHALL HAVE NO GREATER DURATION THAN THE WARRANTY PERIOD SET FORTH ABOVE. UNDER NO CIRCUMSTANCES SHALL CLARION BE LIABLE FOR ANY LOSS OR DAMAGE, DIRECT OR CONSEQUENTIAL, ARISING OUT OF THE USE OR INABILITY TO USE THE PRODUCT. BECAUSE SOME STATES DO NOT ALLOW LIMITATIONS ON HOW LONG AN IMPLIED WARRANTY LASTS OR EXCLUSIONS OR LIMITATIONS OF INCIDENTAL OR CONSEQUENTIAL DAMAGES, THE ABOVE LIMITATIONS OR EXCLUSIONS MAY NOT APPLY TO YOU.
9. **THIS LIMITED WARRANTY GIVES YOU SPECIFIC LEGAL RIGHTS, AND YOU MAY ALSO HAVE OTHER RIGHTS WHICH VARY FROM STATE TO STATE.**
10. The laws of the State of California shall govern and control this limited warranty, its interpretation and enforcement.
11. Should you have any difficulties with the performance of this product during the warranty period, please call or visit our web site for a listing of Authorized Warranty Service Centers in your area. You may also contact the Clarion Customer Service at the address listed below for any service help you may need with Clarion products.

In USA:
 Clarion Corporation of America
 Attn:Customer Service Manager
 661 W. Redondo Beach Blvd
 Gardena, CA.90247-4201
 1-800-GO-CLARION
 (310)327-9100
www.clarion.com

In Canada:
 Clarion Canada Inc.
 Warranty Service Center
 2239 Winston Park Drive
 Oakville, Ontario L6H 5R1
 (905)829-4600
www.clarioncanada.com

WELCOME TO

SIRIUS SATELLITE RADIO

**100 CHANNELS OF THE
BEST ENTERTAINMENT ON THE ROAD**

Clarion

siriusradio.com

YOUR NEW RECEIVER IS READY FOR

100%
COMMERCIAL-FREE
MUSIC



SIRIUS
Satellite Radio

SIRIUS
S>PLEX
SUPERIOR
SOUND
RESOLUTION

SIRIUS **100%**
COMMERCIAL-FREE
MUSIC

**SIRIUS
POP**

- 1 Top 40 Hits
- 2 Adult Contemporary
- 3 Alt Pop Mix
- 4 Love Songs
- 5 The Best of the 50s/60s
- 7 The Best of the 70s
- 8 The Best of the 80s
- 9 The Best of the 90s

**SIRIUS
ROCK**

- 15 Soft Rock
- 17 Eclectic Rock
- 20 Rock Hits
- 21 Modern Rock
- 22 Mainstream Rock
- 23 Classic Rock I
- 24 Classic Rock II
- 25 Classic Alternative
- 26 Alternative I
- 27 Alternative II
- 29 Hard Rock

**SIRIUS
COUNTRY**

- 30 Country Hits
- 31 Today's Country
- 32 Country Mix
- 35 Classic Country
- 36 Alt Country
- 37 Bluegrass

**SIRIUS
R&B/URBAN**

- 40 R&B Hits
- 42 Today's R&B
- 43 Soul Ballads
- 44 Classic Soul
- 45 R&B Oldies
- 47 Rap Hits
- 48 Today's Rap
- 49 Classic Rap

**SIRIUS
DANCE**

- 50 Dance Hits
- 51 Mainstream Dance
- 53 Electronica
- 56 Disco

285-1887-00

**SIRIUS
JAZZ &
STANDARDS**

- 60 Classic Jazz
- 61 Latin Jazz
- 62 Contemporary Jazz
- 63 Smooth Jazz
- 65 Standards
- 66 Swing
- 67 Broadway's Best

**SIRIUS
LATIN**

- 70 Latin Hits
- 71 Latin Pop Mix
- 72 Rock en Español
- 74 Mexicana
- 77 Tejano

**SIRIUS
CLASSICAL**

- 80 Symphonic
- 82 Chamber Works
- 85 Classical Voices

**SIRIUS
VARIETY**

- 90 Blues
- 91 Reggae
- 93 Gospel
- 94 Christian Hits
- 95 World Music
- 96 New Age
- 99 Kids
- 100 Specialty Showcase

**SIRIUS
NEWS**

- 101 CNBC
- 102 FOX News Channel
- 104 CNN Headline News
- 105 Bloomberg
- 107 NPR Now
- 108 NPR Talk
- 109 PRI's Public Radio Channel
- 111 World Radio Network
- 112 BBC World Service News
- 114 C-SPAN Radio
- 115 The Weather Channel
Radio Network
- 116 Sirius Talk
- 117 Real Sirius
- 119 ABC News & Talk

**SIRIUS
SPORTS**

- 120 ESPN Radio Network
- 121 ESPNNews
- 123 Sports Byline USA
- 124 Speedvision
- 125 OLN Adventure Radio

**SIRIUS
HISPANIC TALK**

- 140 BBC Mundo
- 142 La Red Hispana
- 144 Radio Deportivo
- 146 Radio Mujer
- 147 Radio Amigo

**SIRIUS
ENTERTAINMENT**

- 150 Radio Disney
- 151 Discovery Radio
- 152 El Entertainment Radio
- 154 A&E Satellite Radio
- 156 Radio Classics
- 158 SCI FI
- 159 Sirius Entertainment
- 160 Sirius Comedy
- 161 Sirius Arts
- 164 Personal Achievement
- 165 Wisdom Radio
- 167 African American Talk
- 168 The Scandal Channel
- 172 Women's Talk
- 175 Guy Talk
- 180 Trucker Channel
- 184 Preview Channel



SIRIUS
Satellite Radio





**ACTIVATE NOW
YOU'LL NEVER WANT TO LEAVE YOUR CAR**

GET READY FOR 100 CHANNELS OF THE BEST IN-CAR ENTERTAINMENT.

You've just purchased a Sirius Satellite Radio receiver that's going to plug you into 60 original music channels, from today's hits to R&B oldies to classical masterpieces. From authentic country and real bluegrass to cool jazz, hot latin, reggae and rock. Plus 40 channels of world-class sports, news and entertainment, like ESPN, Radio Disney, E! Entertainment Radio, CNBC, Fox News and Discovery Radio.

At Sirius, the emphasis is on the music and entertainment *you* want. From now on, it's just you, the road and the music.

ONLY FROM SIRIUS —

- 100 channels of digital entertainment, coast-to-coast
- 60 original music channels, all commercial-free
- 40 world-class sports, news and entertainment channels
- S>PLEX technology for superior sound resolution

EXPERIENCE SIRIUS IN TWO SIMPLE STEPS.

If you haven't already activated your Sirius receiver, here's how:

1. Contact us at siriusradio.com or call toll-free 1-888-539-SIRIUS (7474).
2. Have 3 items on hand:
 - A valid credit card or branded debit card
 - Sirius ID or Electronic Serial Number (check on the receiver box or your display control window)
 - Your vehicle identification number (VIN)

Activate today to get 100% commercial-free music, plus a Welcome Kit with a detailed Channel Guide.



SIRIUS
Satellite Radio

