

# Owner's Manual & Safety Instructions

**Save This Manual** Keep this manual for the safety warnings and precautions, assembly, operating, inspection, maintenance and cleaning procedures. Write the product's serial number in the back of the manual near the assembly diagram (or month and year of purchase if product has no number). Keep this manual and the receipt in a safe and dry place for future reference.

CENTRAL  
**Forge**

12"

**CERAMIC  
TILE  
CUTTER**

**ITEM 68978**

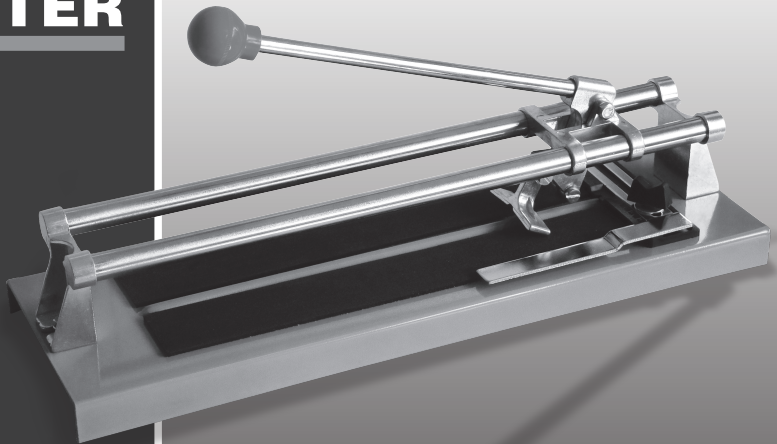

Visit our website at: <http://www.harborfreight.com>  
Email our technical support at: [tech@harborfreight.com](mailto:tech@harborfreight.com)

When unpacking, make sure that the product is intact and undamaged. If any parts are missing or broken, please call 1-800-444-3353 as soon as possible.

Copyright© 2011 by Harbor Freight Tools®. All rights reserved.  
No portion of this manual or any artwork contained herein may be reproduced in any shape or form without the express written consent of Harbor Freight Tools. Diagrams within this manual may not be drawn proportionally. Due to continuing improvements, actual product may differ slightly from the product described herein. Tools required for assembly and service may not be included.

## **⚠ WARNING**

**Read this material before using this product.  
Failure to do so can result in serious injury.  
SAVE THIS MANUAL.**

## Important Safety Information

1. Assemble only according to these instructions. Improper assembly can create hazards.
2. Wear ANSI-approved safety goggles and heavy-duty work gloves during assembly and use.
3. Keep assembly area clean and well lit.
4. Keep bystanders out of the area during assembly.
5. Do not assemble when tired or when under the influence of drugs or medication.
6. This product is not a toy. Do not allow children to play with or near this item.
7. Use as intended only. Do not use handle extension to increase force.
8. Inspect before every use; do not use if parts are loose or damaged.
9. Maintain product labels and nameplates. These carry important safety information. If unreadable or missing, contact Harbor Freight Tools for a replacement.

## Assembly Instructions

1. Insert the threaded end of the Breaking Bar (21) into the Connector (17).
2. Screw the Knob (22) clockwise onto the Breaking Bar until it is tightly in place.

## Operating Instructions

1. Mark the cut line on the tile with a soft carpenter's pencil.
2. Loosen the Try Square Knob (23) and slide the Try Square out so there is room for the tile.
3. With the glazed side up, place the tile against the Ruler Bar (7), with the pencil line directly under the Cutting Wheel (16).
4. Slide the Try Square to the edge of the tile and tighten the Try Square Knob.
5. Holding the tile firmly, score along the pencil line with the Cutting Wheel several times across the pencil line.
6. Raise the Breaking Bar (21), and position the tile so that the front edge of the pencil line is lined up with the center of the Breaking Foot (20).
7. Holding the Knob (22), press down firmly to split the tile along the scored pencil line.

**Note:** Once the Try Square is secured at the desired setting, you can make multiple cuts of the same size without marking the cut line on the tile.

**Note:** The scoring action occurs by moving the Carriage (14) from the back to the front each time and pressing down slightly. At the end of the motion, raise the Breaking Bar, and move it backwards. Repeat this action several times, depending on the thickness of the tile, until a scored line appears.

## Parts List and Assembly Diagram

Part	Description	Qty
1	Nut	2
2	Washer	2
3	Nut	1
4	Spring Washer	1
5	Base	1
6	Foam Plate	2
7	Ruler Bar	1
8	Bolt	2
9	Sliding Bar	2
10	Support	2
11	Flat Washer	2
12	Bolt	2
13	Bolt	1

Part	Description	Qty
14	Carriage	1
15	Arbor	1
16	Cutting Wheel	1
17	Connector	1
18	Lock nut	1
19	Locknut	2
20	Breaking Foot	1
21	Breaking Bar	1
22	Knob	1
23	Try Square Knob	1
24	Washer	1
25	Try Square	1

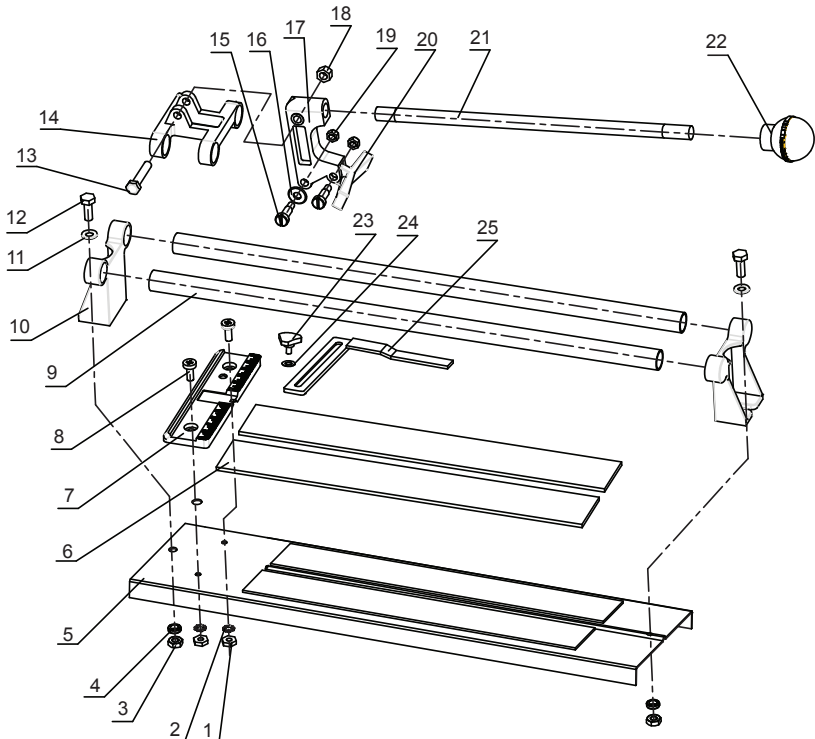

Record Product's Serial Number Here: \_\_\_\_\_

**Note:** If product has no serial number, record month and year of purchase instead.

**Note:** Some parts are listed and shown for illustration purposes only, and are not available individually as replacement parts.

## PLEASE READ THE FOLLOWING CAREFULLY

THE MANUFACTURER AND/OR DISTRIBUTOR HAS PROVIDED THE PARTS LIST AND ASSEMBLY DIAGRAM IN THIS MANUAL AS A REFERENCE TOOL ONLY. NEITHER THE MANUFACTURER OR DISTRIBUTOR MAKES ANY REPRESENTATION OR WARRANTY OF ANY KIND TO THE BUYER THAT HE OR SHE IS QUALIFIED TO MAKE ANY REPAIRS TO THE PRODUCT, OR THAT HE OR SHE IS QUALIFIED TO REPLACE ANY PARTS OF THE PRODUCT. IN FACT, THE MANUFACTURER AND/OR DISTRIBUTOR EXPRESSLY STATES THAT ALL REPAIRS AND PARTS REPLACEMENTS SHOULD BE UNDERTAKEN BY CERTIFIED AND LICENSED TECHNICIANS, AND NOT BY THE BUYER. THE BUYER ASSUMES ALL RISK AND LIABILITY ARISING OUT OF HIS OR HER REPAIRS TO THE ORIGINAL PRODUCT OR REPLACEMENT PARTS THERETO, OR ARISING OUT OF HIS OR HER INSTALLATION OF REPLACEMENT PARTS THERETO.

### Limited 90 Day Warranty

Harbor Freight Tools Co. makes every effort to assure that its products meet high quality and durability standards, and warrants to the original purchaser that this product is free from defects in materials and workmanship for the period of 90 days from the date of purchase. This warranty does not apply to damage due directly or indirectly, to misuse, abuse, negligence or accidents, repairs or alterations outside our facilities, criminal activity, improper installation, normal wear and tear, or to lack of maintenance. We shall in no event be liable for death, injuries to persons or property, or for incidental, contingent, special or consequential damages arising from the use of our product. Some states do not allow the exclusion or limitation of incidental or consequential damages, so the above limitation of exclusion may not apply to you. THIS WARRANTY IS EXPRESSLY IN LIEU OF ALL OTHER WARRANTIES, EXPRESS OR IMPLIED, INCLUDING THE WARRANTIES OF MERCHANTABILITY AND FITNESS.

To take advantage of this warranty, the product or part must be returned to us with transportation charges prepaid. Proof of purchase date and an explanation of the complaint must accompany the merchandise. If our inspection verifies the defect, we will either repair or replace the product at our election or we may elect to refund the purchase price if we cannot readily and quickly provide you with a replacement. We will return repaired products at our expense, but if we determine there is no defect, or that the defect resulted from causes not within the scope of our warranty, then you must bear the cost of returning the product.

This warranty gives you specific legal rights and you may also have other rights which vary from state to state.

