

## Recording/Playback with the Connected Equipment

### Dubbing onto another tape recorder

Connect another tape recorder to the EAR jack using the RK-G64HG connecting cord (not supplied) (For "Sony World Model" : in Japan, use the RK-G64, not supplied).

Set this unit to the playback mode and another tape recorder to the recording mode.

### Recording from another tape recorder (M-637V/635VK/630V only)

Connect another tape recorder to the MIC jack using the RK-G64HG connecting cord (not supplied) (For "Sony World Model" : in Japan, use the RK-G64, not supplied).

Set this unit to the recording mode and another tape recorder to the playback mode. In this case set VOR to OFF.

### Recording with an External Microphone (M-637V/635VK/630V only)

Connect a microphone to the MIC jack.

M-637V for the United States : use the supplied microphone. Other models : use a microphone of low impedance (less than 3 kilohms) such as ECM-T115 (not supplied). When using a plug-in-power system microphone, the power to the microphone is supplied from this unit.

#### Note

When recording with an external microphone, the VOR system may not work properly because of the difference in sensitivity.

## Precautions

### On power

- Operate the unit only on 3 V DC.

For AC operation, use the AC adaptor recommended for the unit. Do not use any other type. For battery operation, use two size AA (R6) batteries.

### On the unit

- Use only the **MICROCASSETTE™** (standard microcassettes) with this unit. Non-standard cassettes cannot be used because their "L" dimension (see illustration) is different.

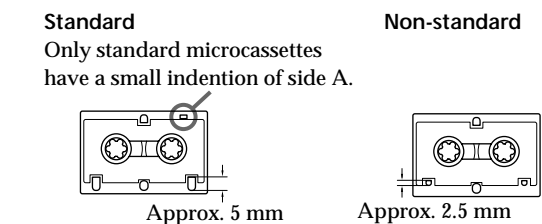

- Do not leave the unit in a location near heat sources, or in a place subject to direct sunlight, excessive dust or mechanical shock.
- Should any solid object or liquid fall into the unit, remove the batteries or disconnect the AC power adaptor, and have the unit checked by qualified personnel before operating it any further.
- Keep personal credit cards using magnetic coding or spring-wound watches etc. away from the unit to prevent possible damage from the magnet used for the speaker.
- When you do not use the unit for long, remove the batteries to avoid damage caused by battery leakage and subsequent corrosion.
- If the unit has not been used for long, set it in the playback mode and warm it up for a few minutes before inserting a cassette.

### For the customers in the USA and Canada

#### RECYCLING NICKEL-CADMIUM BATTERIES

Nickel-Cadmium batteries are recyclable. You can help preserve our environment by returning your unwanted batteries to your nearest point for collection, recycling or proper disposal.

Note: In some areas the disposal of nickel-cadmium batteries in household or business trash may be prohibited.



RBRC (Rechargeable Battery Recycling Corporation) advises you about spent battery collection by the following phone number.

Call toll free number: 1-800-822-8837 (United States and Canada only)

Caution: Do not handle damaged or leaking nickel-cadmium batteries.

If you have any questions or problems concerning your unit, please consult your nearest Sony dealer.

## Troubleshooting

Should any problem persist after you have made these checks, consult your nearest Sony dealer.

### A cassette cannot be inserted.

- The cassette is being inserted in the wrong way.
- ◀ has been already pressed.

### Playback cannot be made.

- The tape has reached the end. Rewind the tape.
- The batteries are weak. Replace both batteries with new ones.
- The head is contaminated.

### Recording cannot be made.

- There is no cassette in the cassette compartment.
- The cassette tab has been removed.
- The batteries are weak. Replace both batteries with new ones.
- The head is contaminated.
- Improper setting of the VOR switch (M-637V/635VK/630V/535V/530V only).

### Recording is interrupted.

- The VOR switch (M-637V/635VK/630V/535V/530V only) is set to H or L. When you do not use VOR, set it to OFF.

### During CUE/REVIEW the tape stops or does not run. You cannot fast-forward or rewind.

- The batteries are weak. Replace both batteries with new ones.

### The unit does not operate.

- The batteries have been inserted with incorrect polarity.
- The batteries are weak. Replace both batteries with new ones.
- ▶PAUSE is slid in the direction of the arrow.
- The AC power adaptor is connected to the unit only and you are going to use the unit on batteries.

### No sound comes from the speaker.

- The earphone is plugged in.
- The volume is turned down completely.

### The sound drops out or comes with excessive noise.

- The volume is turned down completely.
- The batteries are weak. Replace both batteries with new ones.

- The head is contaminated. See "Maintenance".

### Tape speed is too fast or too slow in the playback mode.

- Improper setting of the TAPE SPEED switch. Set it to the same speed as that used for recording.

### Tape speed is faster than the normal playback speed.

- The FAST PB switch (M-637V/635VK/630V only) is slid in the direction of the arrow.

### Recording cannot be erased completely.

- The head is contaminated.

## Maintenance

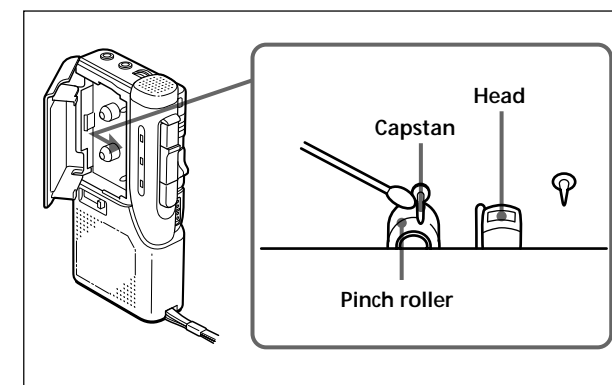

### To clean the tape head and path

Press ▶ and wipe the head, capstan and the pinch roller with a cotton swab, moistened with alcohol every 10 hours of use.

### To clean the exterior

Use a soft cloth slightly moistened in water. Do not use alcohol, benzine or thinner.

## Specifications

### Tape

**MICROCASSETTE™** (normal position type)

### Recording system

2-track 1-channel monaural

### Speaker

Approx. 3.6 cm (1<sup>1</sup>/<sub>16</sub> in.) dia.

### Tape speed

2.4 cm/s (1<sup>5</sup>/<sub>16</sub> ips), 1.2 cm/s (1<sup>1</sup>/<sub>2</sub> ips)

### Frequency range

300 - 4,000 Hz (with TAPE SPEED switch at 2.4 cm/s)

### Input (M-637V/635VK/630V only)

Microphone input jack (minijack/PLUG IN POWER)  
sensitivity 0.24 mV for 3 kilohms or lower impedance microphone

### Output

Earphone jack (minijack) for 8 - 300 ohms earphone

### Power output (at 10% harmonic distortion)

M-637V/635VK/630V/535V/530V 250 mW  
M-430 160 mW

### Power requirements

3 V DC batteries size AA (R6) × 2/External DC 3V power sources

### Dimensions (w/h/d)

Approx. 62.2 × 121.5 × 24.3 mm (2<sup>1</sup>/<sub>2</sub> × 4<sup>7</sup>/<sub>8</sub> × 3<sup>1</sup>/<sub>2</sub> in.) incl. projecting parts and controls

### Mass

Approx. 125 g (4.5 oz)

### Supplied accessories

AC power adaptor (1) (M-635VK only)  
Battery charge adaptor (1) (M-635VK only)  
Rechargeable batteries NC-AA, 1.2 V, 600 mAh, Ni-Cd (2) (M-635VK only)  
Microcassette tape MC-30 (1) (M-637V for the United States, M-630V/535V/530V/430 for Europe and M-430(S) only)  
Batteries R6P (SR) (2) (M-630V for Europe and M-530V "Sony World Model" only)  
Alkaline batteries LR6 (SG) (2) (M-637V for the United States only)  
Carrying pouch (1) (M-637V for the United States, M-630V for Europe and M-530V "Sony World Model" only)  
Microphone (1) (M-637V for the United States only)

Design and specifications are subject to change without notice.

## This warranty is valid only in the United States.



SONY

3-865-285-72 (1)

## Microcassette™ -Corder

Operating Instructions

M-637V/635VK/630V/  
535V/530V/430

Sony Corporation © 1999 Printed in China



For customers in the United States

## Owner's Record

The model number is located at the bottom and the serial number is located inside the battery compartment. Record these numbers in the spaces provided below. Refer to these numbers whenever you call upon your Sony dealer regarding this product.

Model No. \_\_\_\_\_ Serial No. \_\_\_\_\_

You are cautioned that any changes or modifications not expressly approved in this manual could void your authority to operate this equipment.

## WARNING

To prevent fire or shock hazard, do not expose the unit to rain or moisture.

## About This Manual

The instructions in this manual are for 5 models. The M-635VK is the model used for illustration purposes.

Their differences are shown in the table below:

	M-635VK	M-637V/630V	M-535V	M-530V	M-430
TAPE COUNTER	○	○	○	○	—
MIC jack	○	○	—	—	—
BATT lamp	○ (BATT lamps)	○ (BATT lamps)	○ (REC/ BATT)	○ (REC/ BATT)	○
REC lamp	○ (REC lamp)	○ (REC lamp)	○ (REC/ BATT)	○ (REC/ BATT)	—
VOR	○	○	○	○	—
FAST PB	○	○	—	—	—
Handstrap	○	○	○	○	—

○: provided or supplied —: not provided or not supplied

## Preparing Power Sources

Choose one of the following power sources.

### Dry Batteries

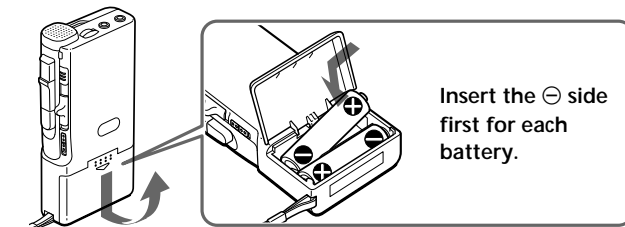

Make sure that nothing is connected to the DC IN 3V jack.

- 1 Open the battery compartment lid.
- 2 Insert two size AA (R6) batteries with correct polarity and close the lid.

### To take out the batteries

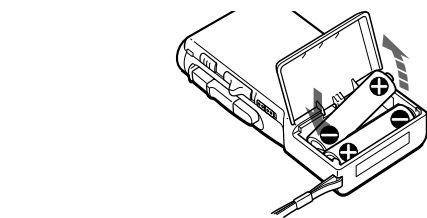

If the battery compartment lid is accidentally detached  
Attach it as illustrated.

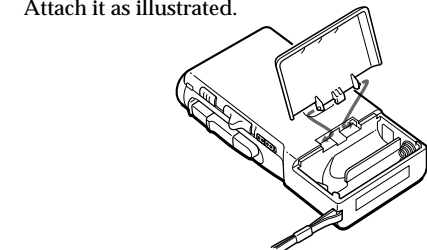

### When to replace the batteries

For M-535V/530V/430  
Replace the batteries with new ones when the REC/BATT (M-535V/530V) or BATT (M-430) lamp dims.

For M-637V/635VK/630V  
Replace the batteries with new ones when the BATT lamps go off and the lamp flashes.  
The BATT lamps change as illustrated:

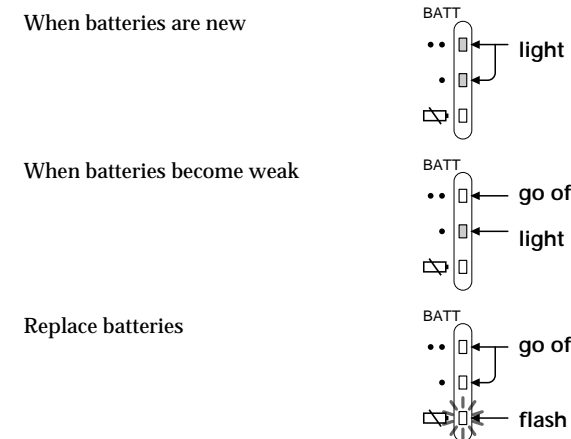

### Notes

- The unit will play back normally for a while, even after the lamp flashes. However, replace the batteries as soon as you can. If you do not, the playback cannot be made with normal sound, noise may be recorded and the recorded sound will not be loud enough (M-637V/635VK/630V only).
- In the following cases you do not need to replace the batteries:
  - if the REC/BATT or BATT lamp, or BATT lamps flash with the playback sound when you turn up the volume.
  - if the lamp lights momentarily when the tape starts running or at the end of the tape (M-637V/635VK/630V only).
  - if the lamp flashes during FF (CUE) or REW (REVIEW) (M-637V/635VK/630V only).

Battery life (Approx. hours)		(EIAJ*)
Batteries	Recording	
Sony manganese R6P (SR)	7	
Sony alkaline LR6 (SG)	24	
NC-AA (M-635VK only)	6.5	

\* Measured valued by the standard of EIAJ (Electronic Industries Association of Japan) (Using a Sony Microcassette)

### Note

The battery life may shorten depending on the operation of the unit.

### House current

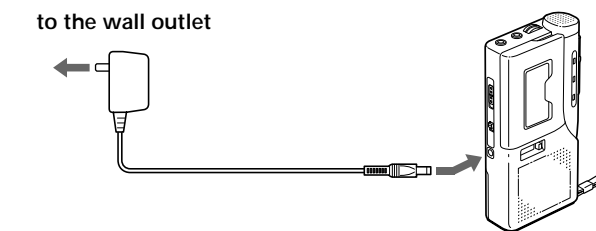

AC power adaptor (supplied with M-635VK only)

Connect the AC power adaptor to DC IN 3V and to a wall outlet. Use the AC power adaptor (supplied with M-635VK only) or the AC-E30HG AC power adaptor (not supplied) (For "Sony World Model": in Japan, use the AC-E30M, not supplied). Do not use any other AC power adaptor.

### Polarity of the plug



### Note

Specifications for AC-E30HG vary for each area. Check your local voltage and the shape of plug before purchasing.

## Rechargeable batteries (supplied with M-635VK only)

Charge the rechargeable batteries only with the supplied charge adaptor and the AC power adaptor. The rechargeable batteries can be charged approximately 500 times.

Be sure to charge the rechargeable batteries for approximately 8 hours before using them. The unit can be used for recording for approximately 6.5 hours with the fully charged rechargeable batteries.

### To charge

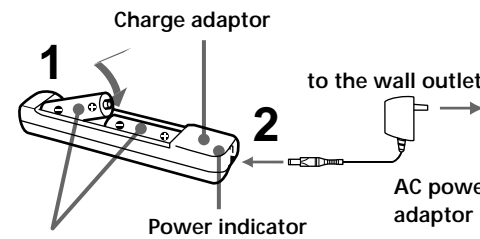

Rechargeable batteries NC-AA

The power indicator of the charge adaptor remains lit as long as power is supplied from the wall outlet.

### To use

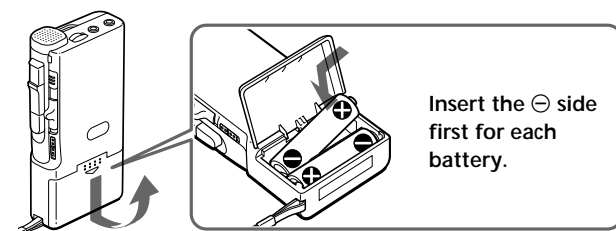

### Notes

- Use the supplied two rechargeable batteries only with the supplied charge adaptor.
- If there is distortion of sound or excessive noise, or if the unit does not operate properly, turn off the unit and recharge the two rechargeable batteries together.
- The rechargeable batteries will discharge even when not in use. Be sure to charge them before use.
- Recharge the two rechargeable batteries together. Otherwise, the charging cannot be done.
- Be sure to remove the rechargeable batteries from the charge adaptor to avoid overcharging (more than 20 hours) when charging has been completed.
- Charging and operation should be made in temperature ranges 5°C to 40°C (40°F to 104°F).
- The charge adaptor will become warm during charging but this is not a sign of problem.
- Do not use or leave the charge adaptor in a location near heat sources or in a place subject to direct sunlight or excessive moisture.
- Unplug the AC power adaptor from the wall outlet when it is not to be used for long.
- Do not attempt to charge dry batteries.

## Recording

Make sure that nothing is connected to MIC (M-637V/635VK/630V only).

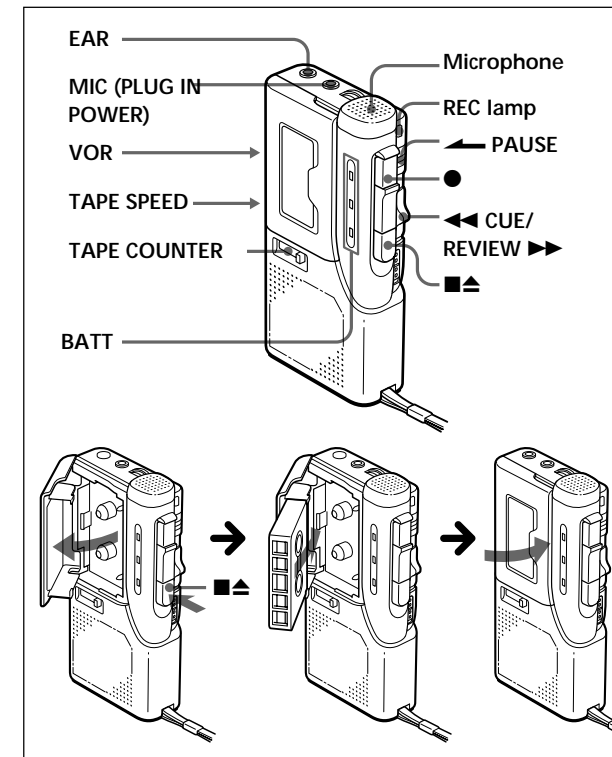

- 1 Press the reset button of the TAPE COUNTER (M-637V/635VK/630V/535V/530V only).
- 2 Press ■▲ and insert a standard microcassette with the side to start recording facing the lid.
- 3 Select the desired tape speed.  
2.4 cm for optimum sound (recommended for normal use):  
A 30-minute recording can be made using both sides of the MC-30 microcassette.  
1.2 cm for longer recording time: A 60-minute recording can be made using both sides of the MC-30 microcassette.
- 4 Set VOR to H, L or OFF (M-637V/635VK/630V/535V/530V only).  
If you set VOR to H or L, the unit automatically starts recording the sound and pauses when there is no sound (you can save tapes and batteries).  
H: To record at meeting or in a quiet and/or spacious place.  
L: To record for dictation or in a noisy place.  
When the sound is not loud enough, set it to OFF, or the unit may not start recording.
- 5 Press ●.  
◀ is pressed simultaneously and recording starts. While the tape runs, the REC lamp or REC/BATT lamp lights and flashes depending on the strength of the sound (M-637V/635VK/630V/535V/530V only).  
Recording level is fixed.

To	Press or slide
Stop recording	■▲
Start recording during playback	● during playback (the unit becomes in the recording mode)
Review the portion just recorded	Push up ◀◀CUE/▶▶REVIEW toward ▶▶REVIEW during the recording. Release the button at the point to start playback.
Pause recording	Slide ◀◀PAUSE in the direction of the arrow. The REC/BATT (M-535V/530V), BATT (M-430) or REC lamp (M-637V/635VK/630V) goes off.
Take out a cassette	■▲

### Note

Select the 2.4 cm tape speed for recording, if you play back the recorded tape with another unit. Otherwise, the sound quality may be changed.

### Notes on VOR (Voice Operated Recording) (M-637V/635VK/630V/535V/530V only)

- The VOR system depends on the environmental conditions. If you cannot get the desired results, set VOR to OFF.
- When you use the system in a noisy place, the unit will stay in the recording mode. If the sound is too soft, on the contrary, the unit will not start recording. Set VOR to H (high) or L (low) depending on the conditions.

### To monitor the sound

Connect an earphone (not supplied) to EAR jack. The monitor volume cannot be adjusted by VOL.

### To prevent a cassette from being accidentally recorded over

Break out and remove the cassette tabs. To reuse the cassette for recording, cover the tab hole with adhesive tape.

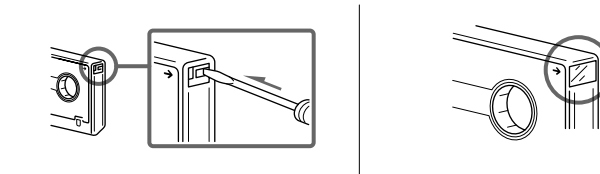

## Playing a Tape

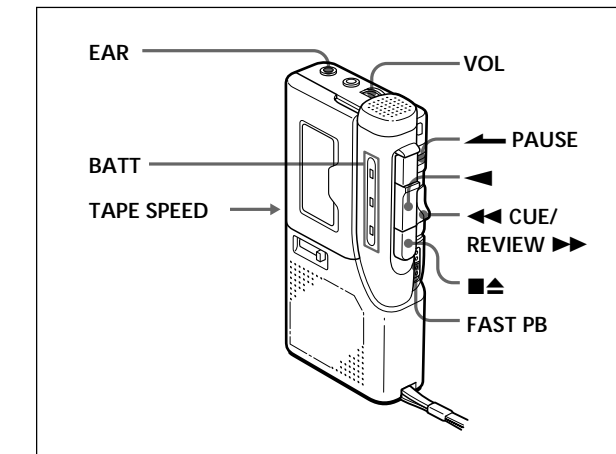

- 1 Insert a cassette with the side to start playing facing the lid.
- 2 Select the tape speed to the same speed as that used for recording.
- 3 Press ◀◀.
- 4 Adjust the volume.

To	Press or slide
Stop playback/stop fast forward or rewind*	■▲
Pause playback	Slide ◀◀PAUSE in the direction of the arrow. The REC/BATT (M-535V/530V) or BATT (M-430) lamp, or BATT lamps (M-637V/635VK/630V) go off.
Fast forward	Slide ◀◀CUE/▶▶REVIEW toward ◀◀CUE during stop.
Rewind	Slide ◀◀CUE/▶▶REVIEW toward ▶▶REVIEW during stop.
Search forward during playback (CUE)	Keep ◀◀CUE/▶▶REVIEW pushed down during playback and release it at the point you want.
Search backward during playback (REVIEW)	Keep ◀◀CUE/▶▶REVIEW pushed up during playback and release it at the point you want.

\* If you leave the unit after the tape has been wound or rewound, the batteries will be consumed rapidly. Be sure to depress ■▲.

### Note

If the tape is completely wound or rewound while searching forward/backward during playback (CUE/REVIEW), the ◀◀CUE/▶▶REVIEW switch may not return to the center position when you release the switch. In this case, push back the switch to the center to start playback.

If you plug in headphones (not supplied) to the EAR jack, you will get monaural output from both left and right channels.

### To increase the playback speed (M-637V/635VK/630V only)

Slide the FAST PB switch in the direction of the arrow. The playback speed will be increased.  
To return to the original speed, slide the FAST PB switch to the original position.

### At the end of the tape

In the recording or playback mode, the tape stops at the end of the tape and the locked buttons will be released automatically (Automatic shut-off mechanism).

After fast forward or rewind, be sure to set ◀◀CUE/▶▶REVIEW back to the center.