

**COMSPHERE  
3550 SERIES  
DATA SERVICE UNITS  
MODELS 3550 AND 3551**

**QUICK REFERENCE**

Document No. 3550-A2-GL10-10

**Copyright © 1999 Paradyne Corporation.**

**All rights reserved.**

**Printed in U.S.A.**

## **Notice**

This publication is protected by federal copyright law. No part of this publication may be copied or distributed, transmitted, transcribed, stored in a retrieval system, or translated into any human or computer language in any form or by any means, electronic, mechanical, magnetic, manual or otherwise, or disclosed to third parties without the express written permission of Paradyne Corporation, 8545 126th Ave. N., Largo, FL 33773.

Paradyne Corporation makes no representation or warranties with respect to the contents hereof and specifically disclaims any implied warranties of merchantability or fitness for a particular purpose. Further, Paradyne Corporation reserves the right to revise this publication and to make changes from time to time in the contents hereof without obligation of Paradyne Corporation to notify any person of such revision or changes.

Changes and enhancements to the product and to the information herein will be documented and issued as a new release to this manual.

## **Warranty, Sales, Service, and Training Information**

Contact your local sales representative, service representative, or distributor directly for any help needed. For additional information concerning warranty, sales, service, repair, installation, documentation, training, distributor locations, or Paradyne worldwide office locations, use one of the following methods:

- **Internet:** Visit the Paradyne World Wide Web site at **www.paradyne.com**. (Be sure to register your warranty there. Select *Service & Support* → *Warranty Registration*.)
- **Telephone:** Call our automated system to receive current information by fax or to speak with a company representative.
  - Within the U.S.A., call 1-800-870-2221
  - Outside the U.S.A., call 1-727-530-2340

## **Document Feedback**

We welcome your comments and suggestions about this document. Please mail them to Technical Publications, Paradyne Corporation, 8545 126th Ave. N., Largo, FL 33773, or send e-mail to **userdoc@paradyne.com**. Include the number and title of this document in your correspondence. Please include your name and phone number if you are willing to provide additional clarification.

## **Trademarks**

All products and services mentioned herein are the trademarks, service marks, registered trademarks or registered service marks of their respective owners.

## COMSPHERE 3550 SERIES DATA SERVICE UNITS MODELS 3550 AND 3551

### Quick Reference

Document Number 3550-A2-GL10-10

March 1999

---

## Product Documentation on the World Wide Web

We provide complete product documentation online. This lets you search the documentation for specific topics and print only what you need, reducing the waste of surplus printing. It also helps us maintain competitive prices for our products.

Complete documentation for this product is available at [www.paradyne.com](http://www.paradyne.com).  
Select *Library* → *Technical Manuals* → *Subrate Digital Access Devices*.

Then select the following document:

3550-A2-GB20

*COMSPHERE 3550 Series Data Service Units,  
Models 3550 and 3551, User's Guide*

To request a paper copy of a Paradyne document:

- Within the U.S.A., call 1-800-PARADYNE (1-800-727-2396)
- Outside the U.S.A., call 1-727-530-8623

## Installation

### HANDLING PRECAUTIONS FOR STATIC-SENSITIVE DEVICES

**This product is designed to protect sensitive components from damage due to electrostatic discharge (ESD) during normal operation. When performing installation procedures, however, take proper static control precautions to prevent damage to equipment. If you are not sure of the proper static control precautions, contact your nearest sales or service representative.**



Before installing your DSU, read the *Important Safety Instructions* on page 23.

Be sure to register your warranty at [www.paradyne.com](http://www.paradyne.com). Select *Service & Support* → *Warranty Registration*.

## Changing the Model 3550 DSU Hardware Straps

The Model 3550 DSU has a switch located behind its diagnostic control panel (DCP). This switch contains two straps, one that controls the permissive or programmable connection when a DBM is installed, and one that controls the frame-to-signal grounds. Table 1 shows the DSU's settings.

### ► Procedure

1. With your thumbs under the edge of the front bezel, firmly press upward to lift the bezel from the tabs securing it in place.
2. Swing the front bezel up and set the bezel aside.
3. Refer to Table 1 to determine which switch needs to be changed. Then, using a small instrument, carefully change the position of the switch.
4. Reinsert the front bezel's hinge tabs into position and swing the bezel down. Snap the bezel back into place.

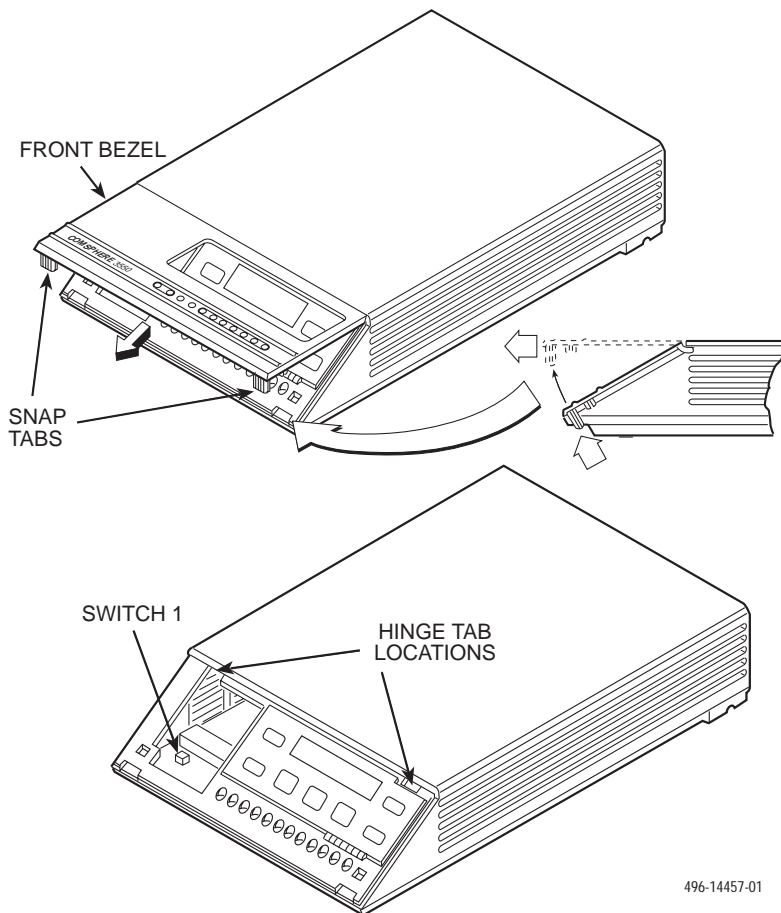

**Table 1. Model 3550 DSU Switch Settings**

<b>Switch Position</b>	<b>Switch Setting</b>	<b>Function</b>
S1-1	ON (default)	Permissive V.32 DBM transmit output level of -9 dBm
	Off	Programmable V.32 DBM transmit level between -12 dBm and 0 dBm
S1-2	ON	Frame ground (FG) connected to signal ground (SG)
	Off (default)	FG connected to SG through 100 ohm resistor

ON is to the rear as you face the front of the DSU.  
Off is to the front.

## Installing the Model 3550 DSU

Before installing the DSU, label the circuit breaker that protects the ac wall outlet, and make sure that it is set to ON. Then, proceed with the installation.

### ► Procedure

1. Place the DSU in its planned location. Make sure the ventilation slots are not blocked.
2. At the rear of the DSU, insert the ac transformer's circular plug into the interface labeled POWER.
3. Plug the ac transformer's 3-prong plug into the ac wall outlet.

### ⚠ WARNING:

**Only use the power transformer designed for the Model 3550 DSU. Using other transformers may result in personal injury or damage to the equipment.**

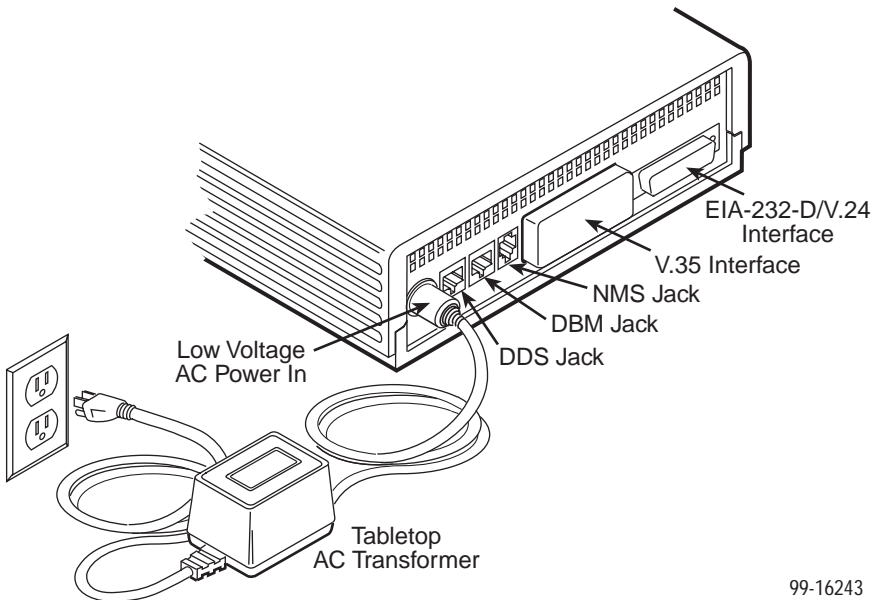

99-16243

## Connecting the Model 3550 DSU to the NMS

A 3600 Hubbing Device is required to connect the control DSU to the 6700 Series NMS. When connected to the NMS, the DSU can be controlled and configured from the NMS rather than from the DCP alone.

### ► Procedure

1. Plug the 4-pin modular plug of the 3600 Hubbing Device into the DSU jack labeled CC/DC.
2. Plug one end of an M6BJ cable into the hubbing device jack labeled CC IN/DC OUT.
3. Plug the other end of the 8-pin M6BJ cable into the 8-pin end of the 873A adapter.
4. Plug the D-type end of the 873A adapter into the appropriate 6700 Series NMS jack.

Refer to your COMSPHERE 6700 Series NMS documentation to control and configure the DSU from the NMS.

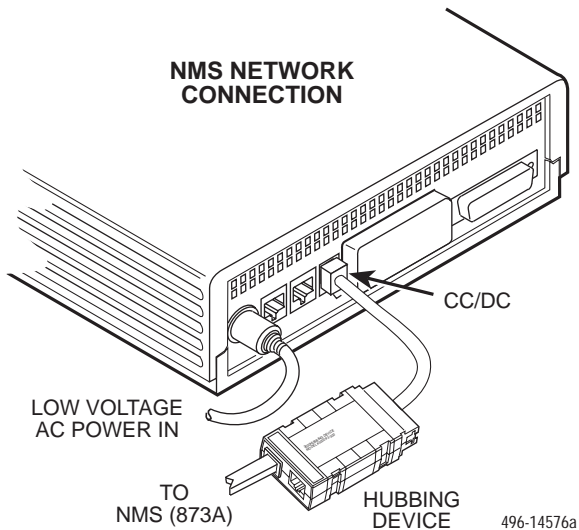

---

## Connecting the Model 3550 DSU to the Dial Network (PSTN)

If your DSU is equipped with a V.32 DBM, follow these steps.

### ► Procedure

1. Plug either end of the dial (analog) interface cable into the DSU jack labeled **BACKUP**.
  - Permissive service – telephone cord with 6-pin modular RJ11C plug
  - Programmable service – telephone cord with 8-pin RJ45S plug
2. Plug the other end of the cable into the modular jack provided by the telephone company, USOC RJ11C (permissive) or USOC RJ45S (programmable).
3. If your site has programmable service, verify that the DSU's hardware strap S1-1 is switched to the Off position.

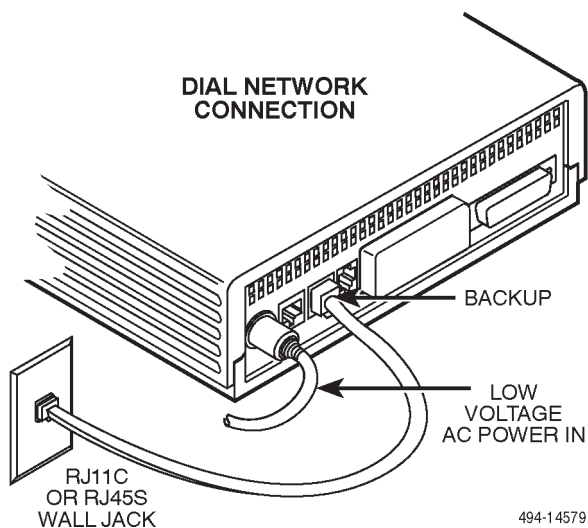



---

## Connecting the Model 3550 DSU to the DDS (or LADS) Network

### NOTE:

Before connecting the DSU to the DDS network, ensure that approved primary protectors have been installed on the circuit in accordance with Article 800 of the National Electric Code, NFPA 70, in the United States and Section 60 of the Canadian Electric Code, Part 1, in Canada.

Follow these steps.

### ► Procedure

1. Plug the DDS network interface cable into the DSU jack labeled LINE.
  - U.S. – select either end of the cable
  - Canada – select the 8-pin end
2. Plug the other end of the cable into the modular jack (USOC RJ48S) provided by the circuit provider.

If the remote DSU is also connected to the network, the DSU's green OK indicator lights and the Alarm indicator goes off. The Health and Status screen no longer displays a *No Signal* message.

If connecting the DSU to a LADS network, note that there are distance limitations that govern the use of DSUs on the network. See the User's Guide for specific information.

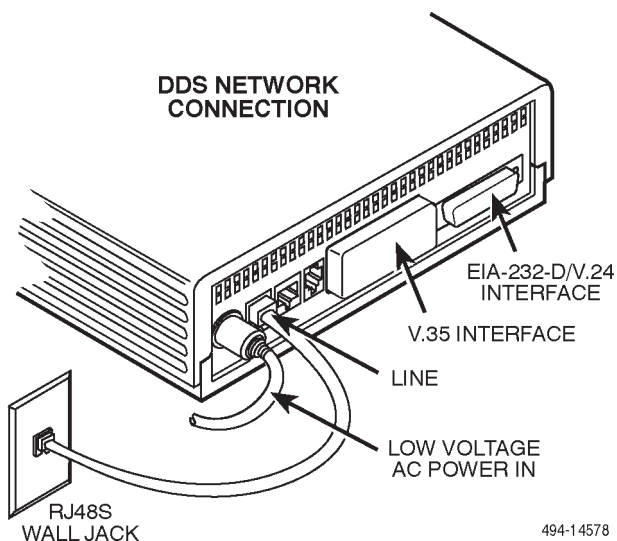

494-14578

## Connecting the Model 3550 DSU to a DTE

The DSU's rear panel has both a 25-pin EIA-232-D/V.24 connector and a 34-pin ITU-T V.35 connector (used for higher operating speeds). You can use either interface.

When the unit is equipped with a TDM/Flex, either of these interfaces can be used as Port 1. The TDM/Flex provides an additional interface to be used as Port 2. This is a D-type connector. If the port is to operate at a speed greater than 19.2 kbps, use the V.35 adapter to provide an interface between the TDM/Flex's D-type connector and the DTE cable's V.35 connector.

Be sure to select the appropriate cable (EIA-232 or V.35) for your application.

### ► Procedure

1. Connect the plug end of the DTE cable to Port 1, either the EIA-232-D or the V.35 connector. Tighten the two holding screws.
2. Connect the other end of the cable to the appropriate port on the computer or DTE. Tighten any holding screws.
3. If necessary, activate the port to match the interface: EIA-232 or V.35. The default setting is EIA-232.

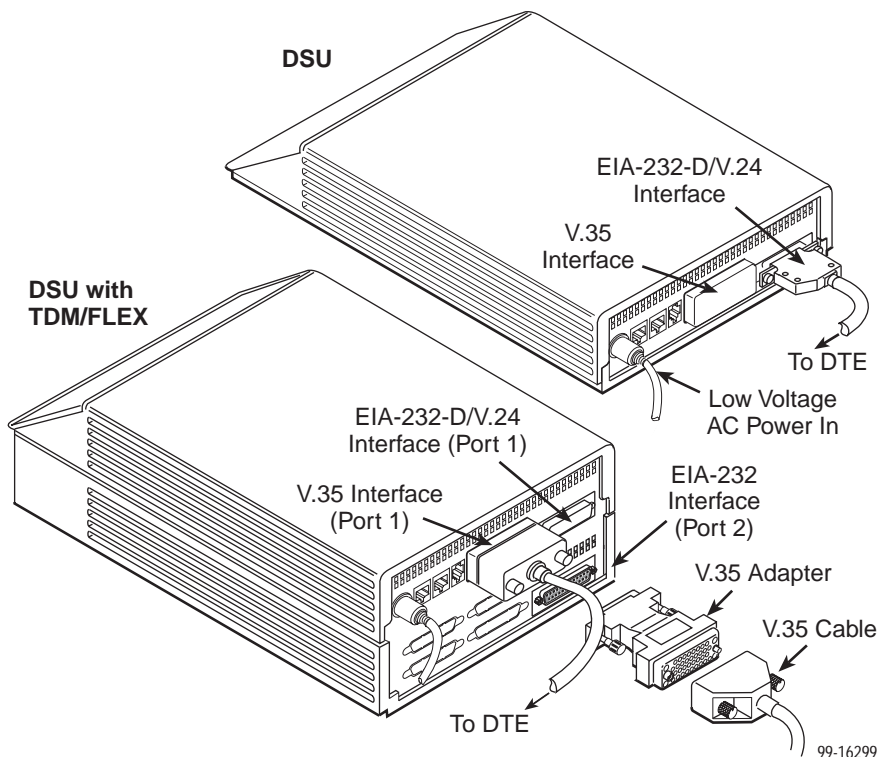

99-16299

## Connecting the Model 3550 DSU's Port 2

For the EIA-232 cable, install as described above.

For the V.35 cable, install the V.35 adapter, then the V.35 DTE cable as follows.

### ► Procedure

1. Reconfigure the port for a V.35 interface. See *General Configuration Options* on page 21.
2. Connect the 25-pin plug end of the V.35 adapter (Feature Number 3000-F1-510) to Port 2. Tighten the thumbscrews.
3. Connect the plug end of the 34-pin V.35 DTE cable to the other end of the V.35 adapter. Tighten the holding screws.
4. Connect the other end of the DTE cable to the appropriate port on the computer or DTE. Tighten the holding screws.

## Changing the Model 3551 DSU Hardware Straps

The Model 3551 DSU has several hardware straps that control the permissive or programmable connection when a DBM is installed, the Test Mode Indication leads, and the external interface leads (used with a -48 Vdc Central Office Power Unit).

Refer to the following figure to locate the switch and jumper locations. If a DBM is installed, refer to Table 2 to determine which switch needs to be changed, if any. Refer to Table 3 to determine whether these jumper straps need to be changed.

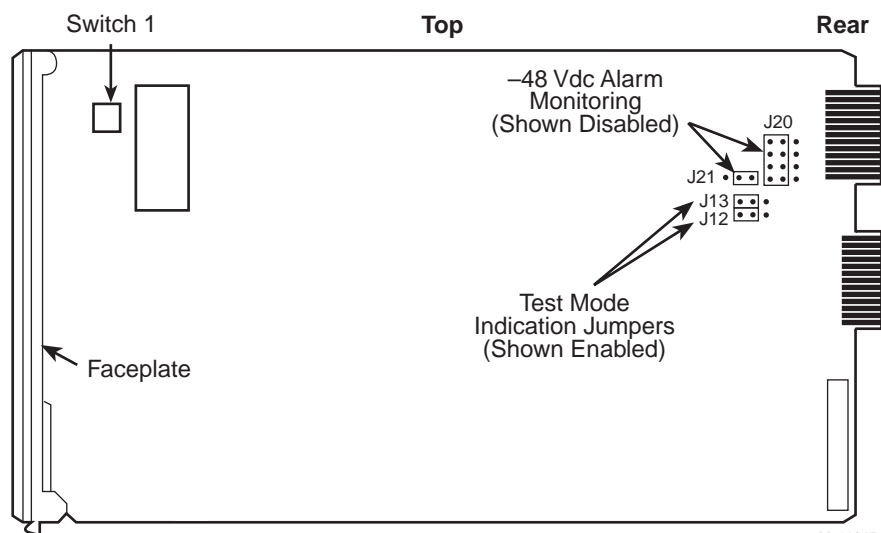

99-16245

**Table 2. Model 3551 DSU Switch Settings**

<b>Switch Position</b>	<b>Switch Setting</b>	<b>Function</b>
S1-1	ON (default)	Permissive V.32 DBM transmit output level of -9 dBm
	Off	Programmable V.32 DBM transmit level between -12 dBm and 0 dBm
S1-2	ON	Frame ground (FG) connected to signal ground (SG)
	Off (default)	FG connected to SG through 100 ohm resistor

ON is to the rear as you face the front of the DSU.  
Off is to the front.

**Table 3. Model 3551 DSU Jumper Straps**

Strap Designation	State of Jumper Strap	Function
J12	Left	<p>V.35 Test Mode Indication:</p> <p><b>Left</b> — Enables V.35 Test Mode Indication (Pins 1 and 2). <i>This is the factory default.</i></p> <p><b>Right</b> — Disables V.35 Test Mode Indication (Pins 2 and 3).</p>
J13	Left	<p>EIA-232-D Test Mode Indication:</p> <p><b>Left</b> — Enables EIA-232-D Test Mode Indication (Pins 1 and 2). <i>This is the factory default.</i></p> <p><b>Right</b> — Disables EIA-232-D Test Mode Indication (Pins 2 and 3).</p>
J20	Left	<p>Alarm Monitoring (used with the –48 Vdc Central Office Power Unit):</p> <p><b>Left</b> — Disables the –48 Vdc alarm monitoring function (Pins 1 and 2). <i>This is the factory default.</i></p> <p><b>Right</b> — Enables the –48 Vdc alarm monitoring function (Pins 2 and 3); the NMS adapter cable is being used for alarm monitoring.</p>
J21	Right	<p>Alarm Monitoring (used with the –48 Vdc Central Office Power Unit):</p> <p><b>Left</b> — Enables control of alarm monitoring via the NMS adapter cable (Pins 1 and 2); the NMS adapter cable is being used for alarm monitoring.</p> <p><b>Right</b> — Disables control of alarm monitoring via the NMS adapter cable (Pins 2 and 3); a standard EIA-232 cable or the NMS adapter cable is being used for the diagnostic channel. <i>This is the factory default.</i></p>

## Installing the Model 3551 DSU

The initial installation procedure for the Model 3551 DSU requires the installation of a rear connector plate onto the rear of the COMSPHERE 3000 Series Carrier. After the initial installation, the DSU can be installed or uninstalled by simply removing the DSU from the carrier.

### ► Procedure

1. At the rear of the carrier, set the tab on the rear connector plate into one of the slotted grooves on the carrier's backplane. Loosely fasten the screws. Make sure the rear connector plate uses the same slot position intended for the DSU.
2. Loosely fasten the screw attached to the rear connector plate, allowing for slight adjustment that may be needed when installing the DSU.
3. Change any default hardware strap settings that may be required before installing the DSU.

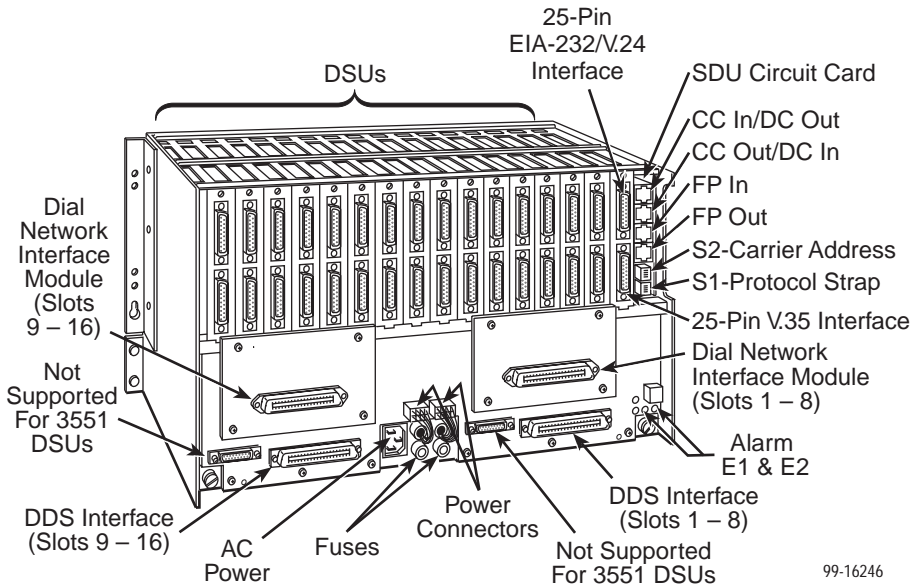

99-16246

4. Using a Phillips screwdriver, loosen the screw holding the circuit pack lock and rotate the lock to the open position. Open the latch.

- At the front of the carrier, hold the DSU vertically with the latch on its faceplate in the open position. Then, insert the circuit card into the top and bottom circuit card guides for the slot that contains the rear connector plate. Slide the DSU into the slot, aligning the circuit card with the rear connector plate until the connectors seat firmly into the back of the carrier. Press the faceplate latch to secure the DSU into the carrier, rotate the circuit pack lock into the closed position, and tighten the screw.
- Return to the rear of the carrier and tighten the rear connector plate screw.

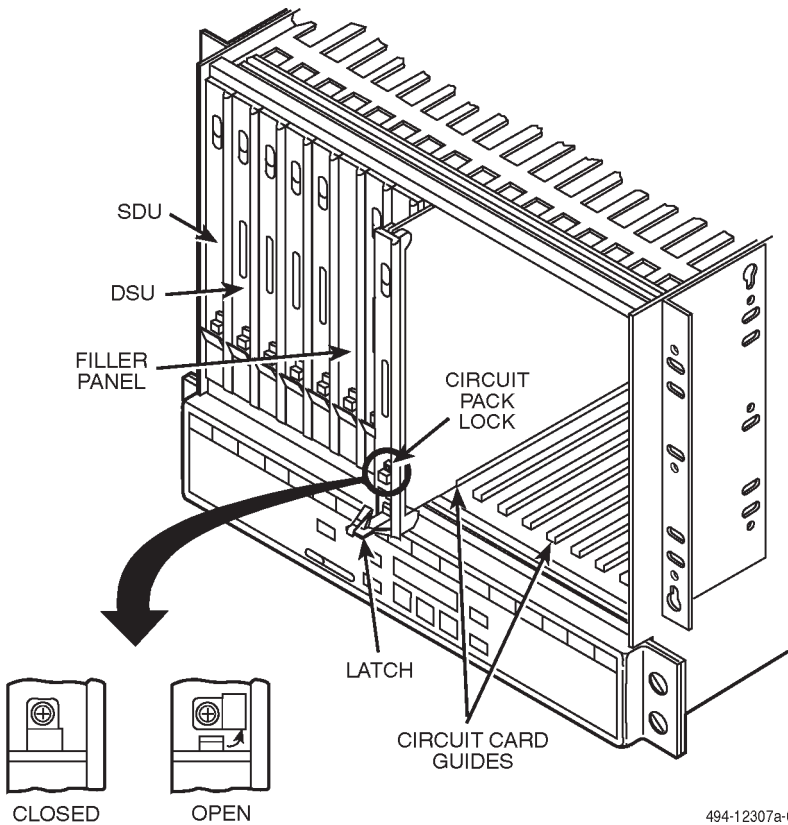

494-12307a-02

- At the rear of the carrier, connect the appropriate DTE interface cable (EIA-232-D or V.35) to the rear connector plate. For an EIA-232-D interface cable, connect the EIA-232-D cable to the top DTE connector on the rear connector plate.

For the 25-pin V.35 interface, a V.35 adapter is shipped with the unit. To connect a V.35 adapter to the 25-pin V.35 connector, perform the following steps:

- Connect the 25-pin end of the V.35 adapter to the bottom DTE connector of the rear connector plate. Tighten the thumbscrews on each side of the connector.
- Connect the V.35 interface cable to the 34-pin end of the V.35 adapter, then tighten the screws on each side of the cable connector.

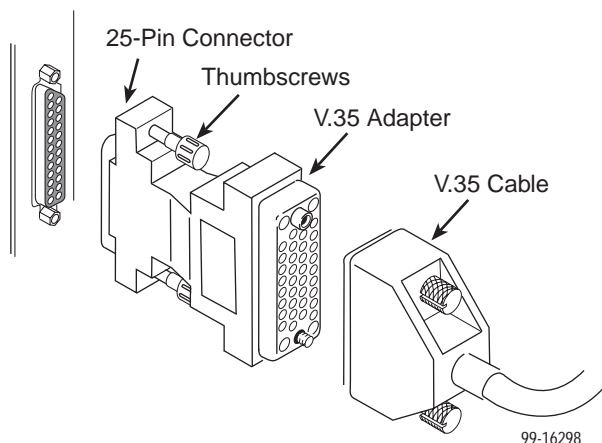

- The installed DSU is connected to the DDS network through the 50-pin connectors at the rear of the carrier. These interfaces are specified in the USOC RJ48T, and the pin assignments are shown in Appendix D of the User's Guide. Proper network connection to the DDS facility or to the network channel-terminating equipment must be made at the far end of the cable.
- If the network line and remote DSU are installed and tested, do a Remote Loopback – a Test Pattern test.
- If the Front Panel test switch strap is to be disabled, slide the DSU slightly out of the carrier, open Switch S3-1, then reseal the DSU into the carrier. Do this now.
- Circuit ID information can be written on the cover plate under the appropriate slot number.



---

## Connecting the Model 3551 DSU to the NMS

A Model 3551 DSU is set up for network diagnostic connection through the shared diagnostic unit (SDU), which is installed in Slot 0 of the carrier. Refer to the *COMSPHERE 3000 Series Carrier Installation Manual*, Document No. 3000-A2-GA31, to set up the network diagnostic connection.

For connection of the DSU, or for pin assignments, see the User's Guide.

## Connecting the Model 3551 DSU to the Dial Network (PSTN)

Connection to the dial network (or public switched telephone network) for the carrier-mounted Model 3551 DSU is through a network interface module (NIM) that is installed onto the carrier's backplane. Refer to the *COMSPHERE 3000 Series Carrier Installation Manual* for additional information or to install the NIM.

## Connecting the Model 3551 DSU to the DDS (or LADS) Network

### NOTE:

Before connecting the DSU to the DDS network, ensure that approved primary protectors have been installed on the circuit in accordance with Article 800 of the National Electric Code, NFPA 70, in the United States and Section 60 of the Canadian Electric Code, Part 1, in Canada.

If connecting the DSU to a LADS network there are distance limitations that govern the use of DSUs on the network. See the User's Guide for specific information.

The DDS network interface is provided by two RJ48T 50-pin connectors on the back of the carrier. Each connector serves eight contiguous slots in the carrier: one for Slots 1 through 8 and one for Slots 9 through 16.

## Connecting the Model 3551 DSU to a DTE

The DTE interface for the Model 3551 DSU is provided through its rear connector plate. Each rear connector plate contains two DB25 (or 25-pin D-type) connectors. The top connector is an EIA-232-D/V.24 (ISO 2110) connector. The bottom connector is an ITU-T V.35 (ISO 2593) connector.

To use the 25-pin V.35 connector (used for speeds greater than 19.2 kbps), a V.35 adapter is needed (Feature Number 3000-F1-510). The adapter provides the interface between the 25-pin V.35 D-type connector and a V.35 DTE cable.

Each DSU can be configured to use either interface (EIA-232 or V.35) independent of other DSUs in the carrier. Connection of the DSU to the DTE is a matter of selecting and installing the appropriate cable. Refer to the *COMSPHERE 3000 Series Carrier Installation Manual* for installation procedures.

## To Connect the SDCP to a DSU

For the carrier-mounted Model 3551 DSU, the SDCP must first be reconnected to the DSU. Once connected, the SDCP operates like a DCP.

### ► Procedure

1. Press the Select key.

A screen similar to the following appears.

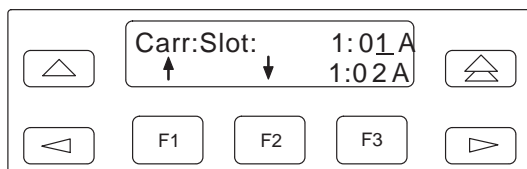

The cursor is usually positioned under the second position of the slot number (1:01).

In this example, the first line shows:

- 1 indicates Carrier 1 (Carr)
- 01 indicates the DSU in Slot 1
- A is reserved for future use

On the second line:

- Press the F1 key (↑) to increment the number that the cursor is on.
- Press the F2 key (↓) to decrement the number.
- Press the ◀ and ▶ keys to move the cursor one position to the left or right, to change either the carrier or slot number.
- Press the F3 key to toggle between DSUs.

2. Press the Select key on the SDCP again.

The SDCP accesses the DSU in Carrier 1, Slot 1. The top-level menu (your starting point) of the carrier-mounted DSU is displayed.

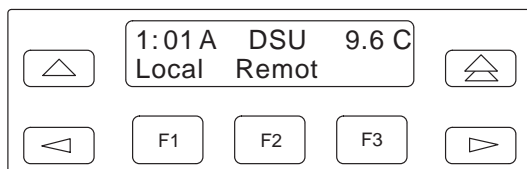

From the first line of this example, you can see that this is a carrier-mounted DSU (1:01A instead of Port1) that is located in Carrier 1, Slot 1, is operating as a DSU (i.e., not as a DBM), at 9.6 kbps, and is configured as a control (C).

From the second line you can see that there are no NMS messages (no *Msg* branch over the F3 key) waiting to be read and cleared.

Also note that the SDCP indicator on the selected DSU's front panel is lit.

---

## Addressing the Unit

A unique address must be assigned to each control and tributary DSU in your network. You can assign an address within the range of 1 through 255.

### NOTES:

- Do not assign the number 192 as a network address. This number is reserved as a broadcast address.
- The numbers 191 and 255 cannot be assigned to a DSU that has a DBM. However, addresses can be assigned in any order; they do not have to be sequential. It is recommended that only odd-numbered addresses be assigned to DSUs so that even-numbered addresses are reserved for DBMs.
- If your network does not currently include DBMs, you retain the flexibility to add them later without having to reconfigure your entire network.

If a DBM is installed, it requires a separate address which is automatically assigned by the DSU. The address assigned a DBM is the DSU's address, plus 1 (for example, if the DSU's address is 1, the assigned DBM address will be 2).

Tributary DSU addresses are user-definable, but take care that their addresses are unique on a multipoint circuit. If two tributaries are assigned the same address, you will not be able to communicate with either one.

---





## Power-Up Routine

When power is applied, the DSU:

- Determines what options (DBM or TDM/Flex) are installed, if any.
- Runs a Device Test on itself and each of the installed options.  
During the tests, all indicators on the DCP light briefly and the message Power-Up Tests appears on the liquid crystal display (LCD).
- Displays the results of each test momentarily as Pass, Fail, or Abrt. (Abrt indicates that the Device Test was aborted because a network loopback was in progress during the power-up procedure.) These tests take about 20 seconds to complete.  
If a TDM/Flex is installed, MUX is displayed as Pass or Fail.

If the DSU or DBM fails this test, follow the procedure below.

### ► Procedure

1. Press the  key to return to the top-level menu.
2. Select Local (F1 key).
3. Press the  key to scroll the Config (Configuration) branch into view.
4. Press the function key directly below Config.
5. Press the F1 key to select Opts (Configuration Options).  
The *Load from* screen appears.
6. Press the  key to bring the factory-loaded unit configurations into view, and select the appropriate configuration.
  - PTPC for a point-to-point control
  - PTPT for a point-to-point tributary
  - MPTC for a multipoint control
  - MPTT for a multipoint tributary
7. Press the F1 key to SAVE the selected configuration.  
The *Save to* screen appears.
8. Save the selected configuration to Activ (F1 key).
9. Press the  key to return to the top-level menu, then select Local again.
10. Select the Test branch (F3).  
The *Run Test on* screen appears.
11. Select the device that Failed: the DSU (or the TDM/Flex) or DBM.
12. Press the F2 key to run the Device Test again.  
The device should pass.
13. Should the device fail, contact your service representative.

## Configuration Options

Configuration options are accessed from the Configuration branch of the front panel menu.

In the following tables, factory defaults are shown in **boldface**. If they differ from each other, defaults are shown for PTPC, PTPT, MPTC, and MPPT.

Key to symbols:

- ◀ These configuration options do **not** appear when Full mode is disabled using Menu from the Configuration branch.

Menu	Value
Full Mode	<b>Enab</b> , Disab

DSU Configuration Options	Value
Rate(Kbps)	64L, 56, 38.4, 19.2, 9.6, 4.8, 2.4
PrtSp(Kbps)	64, 56, 48, 19.2, <b>9.6</b> , 4.8, 2.4, 1.2, Disab
TxCkSource	Int, Ext, Prt1, Prt2, <b>DDS</b>
Msg Clamp	◀ <b>Enab</b> , Disab
TxElasStor	Enab, <b>Disab</b>
RxElasStor	◀ Enab, <b>Disab</b>
19.2 PowrLvl	◀ <b>+6</b> , 0, -10
V.54 Lpbk	◀ Enab, <b>Disab</b>

Diagnostic DSU Configuration Options	Value
Diag Type	NonD, <b>Disr</b> , Mixed, None
2nd Ch(bps)	◀ 100, <b>400</b> , 800, 1200, 1600

Diagnostic DBM Configuration Options	Value
Diag Type	NonD, <b>Disr</b> , Mixed, None
2nd Ch(bps)	◀ 100, <b>400</b> , 800, 1200, 1600

Diagnostic External DBU Configuration Options	Value
Diag Type	<b>Disr</b> , None

Diagnostic General Configuration Options	Value
Position	<b>Cntrl</b> (PTPC, MPTC), <b>Trib</b> (PTPT, MPTT)
LinkConfg	<b>Pt-Pt</b> (PTPC, PTPT), <b>M-Pt</b> (MPTC, MPTT)
Resp Period	◀ 1, 2, 10
TribTimOut	◀ <b>0:10</b> (5 sec to 10 min)
Link Delay	◀ <b>0s</b> , 1s, 2s, 5s, 10s, 20s, 50s
Packet Delay	◀ <b>0s</b> , 1s, 2s, 5s
M-PtSymPrt	◀ <b>Enab</b> , Disab

DBM Configuration Options	Value
Rate(Kbps)	14.4, 12.0, <b>9.6</b> , 4.8, 2.4
PrtSp(Kbps)	14.4, 12.0, <b>9.6</b> , 4.8, 2.4, 1.2, Disab
TxCkSource	<b>Int</b> (PTPC, MPTC), <b>RXC</b> (PTPT, MPTT), Ext, Prt1, Prt2, DSU
CarrLossDisc	◀ <b>Yes</b> , No
Auto Retrain	◀ <b>Yes</b> , No
Single Rate	<b>Yes</b> , No
AutoAnswer	◀ <b>Enab</b> , Disab
TxElasStor	Enab, <b>Disab</b>
RxElasStor	◀ Enab, <b>Disab</b>
Call Setup	<b>None</b> , Pswrd, Cllbk, Alarm
RxPwd	(10 characters)
TxPwd	(10 characters)
V.13 Signl	<b>Enab</b> (MPTC, MPTT), <b>Disab</b> (PTPC, PTPT)
Dial Test	◀ Enab, <b>Disab</b>
DtrCallCon	Ansr, <b>Disab</b>

External DBU Configuration Options	Value
ExtBU	Ansr, Orig, <b>None</b>
Rate(Kbps)	64, 56, 38.4, 28.8, 19.2, 14.4, <b>9.6</b> , 4.8, 2.4, 1.2, Disab
TxCkSource	<b>DCE</b> , Prt1, Prt2

General Configuration Options	Value
DTE Port	<b>EIA232</b> , V.35
RTS Cntrl	<b>FrcOn</b> (PTPC, PTPT, MPTC), <b>DTE</b> (MPTT)
CTS Cntrl	<b>Std</b> , =RTS, Delay, FrcOn
AntiStream	◀ <b>Disab</b> , 1–100 sec
LSD Lead	◀ <b>Std</b> , Delay, FrcOn
DSR FrcOn	◀ <b>Enab</b> , <b>Disab</b>
SystemStat	◀ <b>Enab</b> , <b>Disab</b>
DSR on Tst	◀ <b>Enab</b> , <b>Disab</b>
Circ Assur	◀ Enab, <b>Disab</b>
RespondRDL	◀ <b>Enab</b> (PTPC, PTPT, MPTT), <b>Disab</b> (MPTC)
LL by DTE	◀ Enab, <b>Disab</b>
RL by DTE	◀ Enab, <b>Disab</b>
Bilat Lpbk	◀ Enab, <b>Disab</b>
Ext Leads	◀ ExtLd, <b>Rate</b> , RPower
CCN by EL	◀ Enab, <b>Disab</b>
DTR Alarm	◀ Enab, <b>Disab</b>
Async→Sync	Enab, <b>Disab</b>
AsyncBit/Char	6, 7, <b>8</b> , 9, 10
Stop Bits	<b>1</b> , 2
Overspeed	1.0, <b>2.3</b>

Backup Configuration Options	Value
Auto Bckup	Enab, <b>Disab</b>
Backup Dir	1–10
FacAlOnCMI	◀ Enab, <b>Disab</b>
AutoRestor	Enab, <b>Disab</b>
NtwkTimOut	<b>1:00</b> (PTPC, MPTC), <b>0:20</b> (PTPT, MPTT) (1 sec to 30 min)
RestorTimOut	<b>5 min</b> (1 min to 60 min)
TriesTimeOut	◀ <b>15 min</b> (1 min to 60 min)
MultiCall	◀ Enab, <b>Disab</b>

MUX Setup Configuration Options	Value
MUX Funct	TDM, <b>MCMP</b> , CBrdg, EBrdg, None
Share DevA	Enab, <b>Disab</b>
Port Cntrl	<b>Host</b> , DSD

MUX Port Configuration Options	Value
DTE Port	EIA232, V.35
Async→Sync	Enab, <b>Disab</b>
Async Rate	= <b>Sync</b> , 1800, 1200, 600, 300, 150
AsyncBit/Char	6, 7, <b>8</b> , 9, 10
Stop Bits	<b>1</b> , 2
Overspeed	1.25, <b>2.5</b>
RTS Cntrl	FrcOn, <b>DTE</b>
TxCarrSel	◀ <b>Const</b> , Cntrl
RxCarrSel	◀ <b>Const</b> , Cntrl, Mark
PCC Buffer	Enab, <b>Disab</b>
Elast Stor	◀ Enab, <b>Disab</b>
RTS/CTS Del	◀ <b>0</b> –1040 ms (8 ms increments)
DTR Alarm	◀ Enab, <b>Disab</b>
AntiStream	◀ <b>Disab</b> , 1–100 sec
DSR FrcOn	◀ <b>Enab</b> , Disab
DSR on Tst	◀ <b>Enab</b> , Disab

Port Speed (DSU) Configuration Options	Value
Prt1 (9.6)	64, 56, 48, 19.2, <b>9.6</b> , 4.8, 2.4, 1.2, Disab
Prt2 (9.6)	64, 56, 48, 19.2, <b>9.6</b> , 4.8, 2.4, 1.2, Disab
Underspeed	<b>Disab</b> , Prt1, Prt2

Port Speed (DBM) Configuration Options	Value
Prt1 (9.6)	14.4, 12.0, <b>9.6</b> , 4.8, 2.4, 1.2, Disab
Prt2 (9.6)	14.4, 12.0, <b>9.6</b> (MPTT), 4.8, 2.4, 1.2, <b>Disab</b> (PTPC, PTPT, MPTC)
Underspeed	<b>Disab</b> , Prt1, Prt2

Port Speed (External DBU) Configuration Options	Value
Prt1 (9.6)	64, 56, 48, 28.8, 19.2, 14.4, <b>9.6</b> , 4.8, 2.4, 1.2, Disab
Prt2 (9.6)	64, 56, 48, 28.8, 19.2, 14.4, <b>9.6</b> , 4.8, 2.4, 1.2, Disab
Underspeed	<b>Disab</b> , Prt1, Prt2



---

## Important Safety Instructions

1. Read and follow all warning notices and instructions marked on the product or included in the manual.
2. This product is intended to be used with a 3-wire grounding type plug – a plug which has a grounding pin. This is a safety feature. Equipment grounding is vital to ensure safe operation. Do not defeat the purpose of the grounding type plug by modifying the plug or using an adapter.  

Prior to installation, use an outlet tester or a voltmeter to check the ac receptacle for the presence of earth ground. If the receptacle is not properly grounded, the installation must not continue until a qualified electrician has corrected the problem. If a 3-wire grounding type power source is not available, consult a qualified electrician to determine another method of grounding the equipment.
3. Slots and openings in the cabinet are provided for ventilation. To ensure reliable operation of the product and to protect it from overheating, these slots and openings must not be blocked or covered.
4. Do not allow anything to rest on the power cord and do not locate the product where persons will walk on the power cord.
5. Do not attempt to service this product yourself, as opening or removing covers may expose you to dangerous high voltage points or other risks. Refer all servicing to qualified service personnel.
6. General purpose cables are provided with this product. Special cables, which may be required by the regulatory inspection authority for the installation site, are the responsibility of the customer.
7. When installed in the final configuration, the product must comply with the applicable Safety Standards and regulatory requirements of the country in which it is installed. If necessary, consult with the appropriate regulatory agencies and inspection authorities to ensure compliance.
8. A rare phenomenon can create a voltage potential between the earth grounds of two or more buildings. If products installed in separate buildings are **interconnected**, the voltage potential may cause a hazardous condition. Consult a qualified electrical consultant to determine whether or not this phenomenon exists and, if necessary, implement corrective action prior to interconnecting the products.
9. In addition, if the equipment is to be used with telecommunications circuits, take the following precautions:
  - Never install telephone wiring during a lightning storm.
  - Never install telephone jacks in wet locations unless the jack is specifically designed for wet locations.
  - Never touch uninsulated telephone wires or terminals unless the telephone line has been disconnected at the network interface.
  - Use caution when installing or modifying telephone lines.
  - Avoid using a telephone (other than a cordless type) during an electrical storm. There may be a remote risk of electric shock from lightning.
  - Do not use the telephone to report a gas leak in the vicinity of the leak.

---

## Notices

### WARNING:

THIS EQUIPMENT HAS BEEN TESTED AND FOUND TO COMPLY WITH THE LIMITS FOR A CLASS A DIGITAL DEVICE, PURSUANT TO PART 15 OF THE FCC RULES. THESE LIMITS ARE DESIGNED TO PROVIDE REASONABLE PROTECTION AGAINST HARMFUL INTERFERENCE WHEN THE EQUIPMENT IS OPERATED IN A COMMERCIAL ENVIRONMENT. THIS EQUIPMENT GENERATES, USES, AND CAN RADIATE RADIO FREQUENCY ENERGY AND, IF NOT INSTALLED AND USED IN ACCORDANCE WITH THE INSTRUCTION MANUAL, MAY CAUSE HARMFUL INTERFERENCE TO RADIO COMMUNICATIONS. OPERATION OF THIS EQUIPMENT IN A RESIDENTIAL AREA IS LIKELY TO CAUSE HARMFUL INTERFERENCE IN WHICH CASE THE USER WILL BE REQUIRED TO CORRECT THE INTERFERENCE AT HIS OWN EXPENSE. THE AUTHORITY TO OPERATE THIS EQUIPMENT IS CONDITIONED BY THE REQUIREMENTS THAT NO MODIFICATIONS WILL BE MADE TO THE EQUIPMENT UNLESS THE CHANGES OR MODIFICATIONS ARE EXPRESSLY APPROVED BY PARADYNE.

### WARNING:

TO USERS OF DIGITAL APPARATUS IN CANADA: THIS CLASS A DIGITAL APPARATUS MEETS ALL REQUIREMENTS OF THE CANADIAN INTERFERENCE-CAUSING EQUIPMENT REGULATIONS.

CET APPAREIL NUMÉRIQUE DE LA CLASSE A RESPECTE TOUTES LES EXIGENCES DU RÈGLEMENT SUR LE MATÉRIEL BROUILLEUR DU CANADA.

## Government Requirements

The Federal Communications Commission (FCC) requires that instructions pertaining to connection to the telephone network be included in the installation and operation manual. Specific instructions are listed in this section.

### Notice to Users of the Digital Data Service

This equipment complies with Part 68 of the FCC rules. On the bottom of the equipment is a label or silkscreened text that contains, among other information, the FCC registration number and Ringer Equivalence Number (REN) for this equipment. If requested, please provide this information to your telephone company.

The REN is useful to determine the quantity of devices you may connect to your telephone line and still have all of those devices ring when your number is called. In most, but not all areas, the sum of the RENs of all devices should not exceed 5. To be certain of the number of devices you may connect to your line, as determined by the REN, you should call your local telephone company to ascertain the maximum REN for your calling area.

---

If your DSU causes harm to the telephone network, the telephone company may discontinue your service temporarily. If possible, they will notify you in advance. But if advance notice is not practical, you will be notified as soon as possible. You will be advised of your right to file a complaint with the FCC.

If your DSU causes harm to the telephone network, the telephone company may discontinue your service temporarily. If possible, they will notify you in advance. But if advance notice is not practical, you will be notified as soon as possible. You will be advised of your right to file a complaint with the FCC.

Your telephone company may make changes in its facilities, equipment, operations, or procedures that could affect the proper operation of your equipment. If so, you will be given advance notice so as to give you an opportunity to maintain uninterrupted service.

The DBM cannot be used on public coin-operated telephone service provided by the telephone company. Connection to party-line service is subject to state tariffs. (Contact the state public utility commission, public service commission, or corporation commission for information.)

No repairs may be performed by the user. Should you experience difficulty with this equipment, refer to the *Warranty, Sales, Service and Training Information* in the front of this document.

For Digital Data Service (DDS) installations, inform the local telephone company of the appropriate network channel interface code for the service you desire.

<b>Interface Code</b>	<b>Data Rate (bps)</b>
04DU5-24	2400
04DU5-48	4800
04DU5-96	9600
04DU5-19	19,200
04DU5-56	56,000

The DDS Service Order Number is 6.0Y. The jack configurations required are RJ48S for the Model 3550 DSU and RJ48T for the Model 3551. With an RJ48T configuration, you must specify the number of data lines you require. Refer to *Technical Specifications* in the User's Guide for V.32 DBM jack information.

After the telephone company has installed the requested jack, you can connect the DSU with the appropriate cable (provided). An FCC-compliant telephone cord and modular plug is provided with this equipment. This equipment is designed to be connected to the telephone network or premises wiring using a compatible modular jack that is Part 68 compliant.